

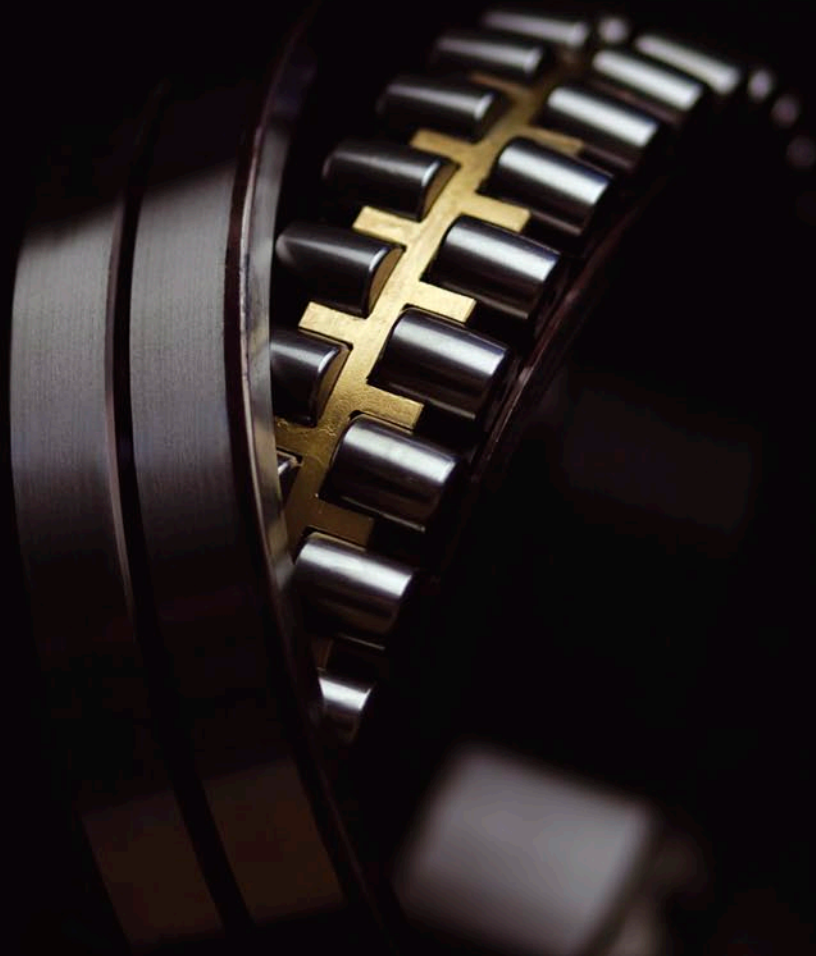

**ZKL** GROUP



# ROLLING BEARINGS

---





# ROLLING BEARINGS

An accuracy of the data contained in this publication has been checked with the utmost care, but we are not responsible for any damages, whether direct, indirect or consequential, which would be caused by the use of the information contained herein.

# Contents

Foreword	6
<b>1. Basic Calculations</b>	<b>7</b>
1.1 Dynamic Load	7
1.1.1 Basic Dynamic Load Rating	7
1.1.2 Life	7
1.1.3 Equivalent Dynamic Load	14
1.1.4 Temperature Influence	16
1.2. Static Load	17
1.2.1 Basic Static Load Rating	17
1.2.2 Equivalent Static Load	17
1.2.3 Bearing Safety under Static Load	18
1.3 Limiting Speed	18
<b>2. Rolling Bearing Design Data</b>	<b>19</b>
2.1 Boundary Dimensions	19
2.2 Designation	20
2.3 Tolerance	27
2.4 Internal Clearance	38
2.5 Cages	42
2.6 Shields and Seals	42
<b>3. Bearing Arrangement Design</b>	<b>43</b>
3.1 General Principles of Rolling Bearing Arrangement Design	43
3.2 Bearing Location	44
3.2.1 Radial Location of Bearings	44
3.2.2 Axial Location of Bearings	46
3.3 Sealing	51
3.3.1 Non-Contact Sealing	51
3.3.2 Rubbing Sealing	52
3.3.3 Combined Sealing	53
<b>4. Bearing Lubrication</b>	<b>54</b>
4.1 Grease Lubrication	54
4.1.1 Relubrication Interval	54
4.1.2 Bearing Greases	54
4.2 Oil Lubrication	57
4.2.1 Bearings Oils	57
4.3 Lubrication with Solid Lubricants	60
<b>5. Mounting and Dismounting of Rolling Bearings</b>	<b>60</b>
<b>6. Rolling Bearing Tables</b>	<b>62</b>
Single Row Deep Groove Ball Bearings	64
Single Row Angular Contact Ball Bearings	86
Double Row Angular Contact Ball Bearings	102
Double Row Self-Aligning Ball Bearings	106
Single Row Cylindrical Roller Bearings	112
Double Row Cylindrical Roller Bearings	128
Single Row Needle Roller Bearings	132
Double Row Spherical Roller Bearings	136
Tapered Roller Bearings	152
Thrust Ball Bearings	174
Spherical Roller Thrust Bearings	184
Insert Ball Bearing Units	194
Spherical Plain Bearings	206
Accessories of Rolling Bearings	210
Rolling Elements	220
Special Rolling Bearings	226



Publication Rolling Bearings ZKL shows a survey of standardized rolling bearings and accessories being produced and delivered under designation ZKL.

In the design, production, the storage and sales of the rolling bearings international standards ISO and national standards are used.

Technical section of the publication contains the most important facts concerning calculations, the design data about the arrangement design, lubrication, as well as mounting and dismounting of rolling bearings. The produced standardized rolling bearings and accessories in the basic design and in the main applications from the basic design, as e. g. bearings with tapered bore, shielded bearings or bearings with snap ring groove on outer ring, etc., are shown in the part Rolling Bearings Dimension Tables.

## ZKL Group

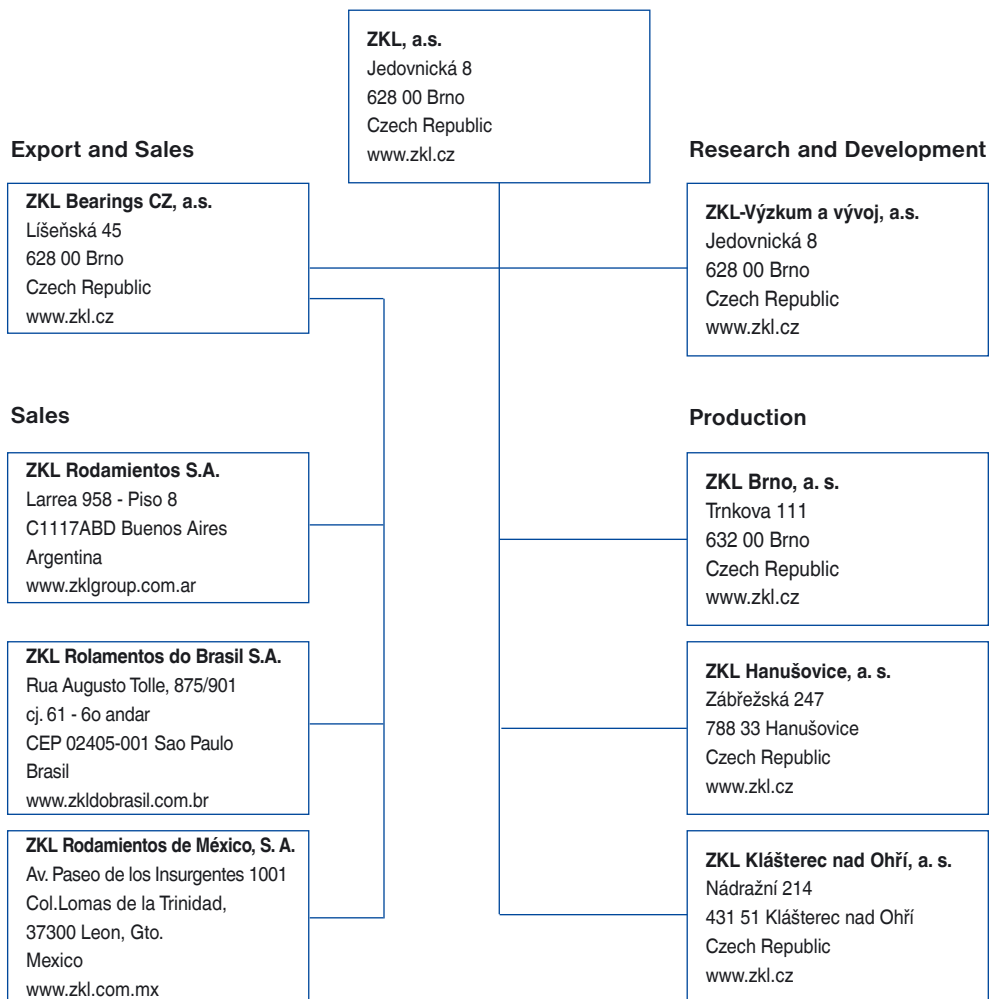

# 1. Basic Calculations

Required bearing size is determined by the action of the external forces and according to the bearing required life and its reliability in the arrangement. Magnitude, direction and kind of load acting on the bearing, as well as the operating speed, are decisive for the type and bearing size selection. Other special or important conditions of each individual arrangement must be taken into account, e.g. operating temperature, limited space availability, simplicity of mounting, lubrication requirements, sealing, etc., and all of these can influence selection of the most suitable bearing. For given concrete conditions various bearing types can meet those requirements.

From the point of view of outer load acting and the bearing function in respective arrangement or unit we distinguish two types of the rolling bearing load in the bearing technique :

- when rolling bearing rings are relatively rotating against each other and bearing is under outer load (which is valid for most bearings), this is called dynamic bearing load,

- when rolling bearing rings either do not move against each other or they move only very slowly, the bearing carries an oscillating motion or the outer load acts for a shorter time than one bearing revolution, this is called static bearing load.

For bearing safety calculation, the life limited by bearing breakdown due to material fatigue of a bearing component is decisive in the first case. In the second case there are durable deformations of functional surfaces on the contact surfaces of rolling elements and raceways.

## 1.1 Dynamic Load

### 1.1.1 Basic Dynamic Load Rating

Basic dynamic load rating is a constant invariable load which the bearing can theoretically carry at the nominal life of one million revolutions.

For radial bearings, the radial dynamic load rating  $C_r$  refers to constant load. For thrust bearings, the axial dynamic load rating  $C_a$  refers to unvariable, purely axial load, acting centrally.

Basic dynamic load ratings  $C_r$  and  $C_a$ , whose size depends on bearing dimensions, rolling element number, material and bearing design, are shown for each bearing in the dimension tables. Values of the basic dynamic load ratings were stated according to the standard ISO 281. These values are verified in testing equipments and by operation results.

### 1.1.2 Life

Rolling bearing life is defined as the number of revolution carried out by one bearing ring against the other ring, until the first signs of material fatigue occur on one ring or the rolling element.

Great differences in life can occur among bearings of the same type, that is why according to the standard ISO 281 the basic life is used as the basis for life calculation, i.e. life shown by the operation time attained or exceeded by a bearing group at 90% reliability.

### Life Equation

Nominal bearing life is mathematically defined by the life equation valid for all bearing types.

$$L_{10} = \left(\frac{C}{P}\right)^p \quad \text{or} \quad \frac{C}{P} = (L_{10})^{\frac{1}{p}}$$

$L_{10}$  - nominal life [10<sup>6</sup>ot]

$C$  - basic dynamic load rating  
(values  $C_r, C_a$  are given in the dimension tables) [kN]

$P$  - equivalent dynamic bearing load (equations for  $P_r, P_a$  calculations are in section 1.1.3 and at each design group of bearings) [kN]

$p$  - exponent for ball bearings  $p = 3$   
for cylindrical, needle-, spherical- and tapered roller bearings  $p = \frac{10}{3}$

Table 1 shows dependence of the life  $L_{10}$  in million revolutions and respective ratio  $C/P$ .

If the rotational speed does not change, the revised life calculation expressing the nominal life in operation hours can be used:

$$L_{10h} = \left(\frac{C}{P}\right)^p \cdot \frac{10^6}{60 \cdot n} \quad [h]$$

$L_{10h}$  - nominal life

[h]

$n$  - rotational speed

[ $\text{min}^{-1}$ ]

$C/P$  dependence from the nominal life  $L_{10}$  and the rotational speed  $n$  is shown for ball bearings in Table 2, for cylindrical roller, needle roller, spherical roller and tapered roller bearings in Table 3.

C/P ratio in dependence on life $L_{10h}$								Table 1
For ball bearings				For cylindrical roller, needle roller, spherical roller and tapered roller bearings				
Life $L_{10}$	$\frac{C}{P}$	Life $L_{10}$	$\frac{C}{P}$	Life $L_{10}$	$\frac{C}{P}$	Life $L_{10}$	$\frac{C}{P}$	
10 <sup>6</sup> ot		10 <sup>6</sup> ot		10 <sup>6</sup> ot		10 <sup>6</sup> ot		
0,5	0,793	600	8,43	0,5	0,812	600	6,81	
0,75	0,909	650	8,66	0,75	0,917	650	6,98	
1	1	700	8,88	1	1	700	7,14	
1,5	1,14	750	9,09	1,5	1,13	750	7,29	
2	1,26	800	9,28	2	1,24	800	7,43	
3	1,44	850	9,47	3	1,39	850	7,56	
4	1,59	900	9,65	4	1,52	900	7,70	
5	1,71	950	9,83	5	1,62	950	7,82	
6	1,82	1000	10	6	1,71	1000	7,94	
8	2	1100	10,3	8	1,87	1100	8,17	
10	2,15	1200	10,6	10	2	1200	8,39	
12	2,29	1300	10,9	12	2,11	1300	8,59	
14	2,41	1400	11,2	14	2,21	1400	8,79	
16	2,52	1500	11,4	16	2,30	1500	8,97	
18	2,62	1600	11,7	18	2,38	1600	9,15	
20	2,71	1700	11,9	20	2,46	1700	9,31	
25	2,92	1800	12,2	25	2,63	1800	9,48	
30	3,11	1900	12,4	30	2,77	1900	9,63	
35	3,27	2000	12,6	35	2,91	2000	9,78	
40	3,42	2200	13	40	3,02	2200	10,1	
45	3,56	2400	13,4	45	3,13	2400	10,3	
50	3,68	2600	13,8	50	3,23	2600	10,6	
60	3,91	2800	14,1	60	3,42	2800	10,8	
70	4,12	3000	14,4	70	3,58	3000	11	
80	4,31	3500	15,2	80	3,72	3500	11,5	
90	4,48	4000	15,9	90	3,86	4000	12	
100	4,64	4500	16,5	100	3,98	4500	12,5	
120	4,93	5000	17,1	120	4,20	5000	12,9	
140	5,19	5500	17,7	140	4,40	5500	13,2	
160	5,43	6000	18,2	160	4,58	6000	13,6	
180	5,65	7000	19,1	180	4,75	7000	14,2	
200	5,85	8000	20	200	4,90	8000	14,8	
250	6,30	9000	20,8	250	5,24	9000	15,4	
300	6,69	10000	21,5	300	5,54	10000	15,8	
350	7,05	12500	23,2	350	5,80	12500	16,9	
400	7,37	15000	24,7	400	6,03	15000	17,9	
450	7,66	17500	26	450	6,25	17500	18,7	
500	7,94	20000	27,1	500	6,45	20000	19,5	
550	8,19	25000	29,2	550	6,64	25000	20,9	

C/P ratio in dependence on life  $L_{10h}$  and rotational speed  $n$  for ball bearings

Table 2

Life $L_{10h}$	Rotational speed $n$ [min <sup>-1</sup> ]													
	10	16	25	40	63	100	125	160	200	250	320	400	500	630
h														
100	-	-	-	-	-	-	-	-	1,06	1,15	1,24	1,34	1,45	1,56
500	-	-	-	1,06	1,24	1,45	1,56	1,68	1,82	1,96	2,12	2,29	2,47	2,67
1 000	-	-	1,15	1,34	1,56	1,82	1,96	2,12	2,29	2,47	2,67	2,88	3,11	3,36
1 250	-	1,06	1,24	1,45	1,68	1,96	2,12	2,29	2,47	2,67	2,88	3,11	3,36	3,63
1 600	-	1,15	1,34	1,56	1,82	2,12	2,29	2,47	2,67	2,88	3,11	3,36	3,63	3,91
2 000	1,06	1,24	1,45	1,68	1,96	2,29	2,47	2,67	2,88	3,11	3,36	3,63	3,91	4,23
2 500	1,15	1,34	1,56	1,82	2,12	2,47	2,67	2,88	3,11	3,36	3,63	3,91	4,23	4,56
3 200	1,24	1,45	1,68	1,96	2,29	2,67	2,88	3,11	3,36	3,63	3,91	4,23	4,56	4,93
4 000	1,34	1,56	1,82	2,12	2,47	2,88	3,11	3,36	3,63	3,91	4,23	4,56	4,93	5,32
5 000	1,45	1,68	1,96	2,29	2,67	3,11	3,36	3,63	3,91	4,23	4,56	4,93	5,32	5,75
6 300	1,56	1,82	2,12	2,47	2,88	3,36	3,63	3,91	4,23	4,56	4,93	5,32	5,75	6,20
8 000	1,68	1,96	2,29	2,67	3,11	3,63	3,91	4,23	4,56	4,93	5,32	5,75	6,20	6,70
10 000	1,82	2,12	2,47	2,88	3,36	3,91	4,23	4,56	4,93	5,32	5,75	6,20	6,70	7,23
12 500	1,96	2,29	2,67	3,11	3,36	4,23	4,56	4,93	5,32	5,75	6,20	6,70	7,23	7,81
16 000	2,12	2,47	2,88	3,36	3,91	4,56	4,93	5,23	5,75	6,20	6,70	7,23	7,81	8,43
20 000	2,29	2,67	3,11	3,63	4,23	4,93	5,32	5,75	6,20	6,70	7,23	7,81	8,43	9,11
25 000	2,47	2,88	3,36	3,91	4,56	5,32	5,75	6,20	6,70	7,23	7,81	8,43	9,11	9,83
32 000	2,67	3,11	3,63	4,23	4,93	5,75	6,20	6,70	7,23	7,81	8,43	9,11	9,83	10,6
40 000	2,88	3,36	3,91	4,56	5,32	6,20	6,70	7,23	7,81	8,43	9,11	9,83	10,6	11,5
50 000	3,11	3,63	4,23	4,93	5,75	6,70	7,23	7,81	8,43	9,11	9,83	10,6	11,5	12,4
63 000	3,36	3,91	4,56	5,32	6,20	7,23	7,81	8,43	9,11	9,83	10,6	11,5	12,4	13,4
80 000	3,36	4,23	4,93	5,75	6,70	7,81	8,43	9,11	9,83	10,6	11,5	12,4	13,4	14,5
100 000	3,91	4,56	5,32	6,20	7,23	8,43	9,11	9,83	10,6	11,5	12,4	13,4	14,5	15,6
200 000	4,93	5,75	6,70	7,81	9,11	10,6	11,5	12,4	13,4	14,5	15,6	16,8	18,2	19,6

Life $L_{10h}$	Rotational speed $n$ [min <sup>-1</sup> ]													
	800	1000	1250	1600	2000	2500	3200	4000	5000	6300	8000	10000	12500	16000
h														
100	1,68	1,82	1,96	2,12	2,29	2,47	2,67	2,88	3,11	3,36	3,63	3,91	4,23	4,56
500	2,88	3,11	3,36	3,63	3,91	4,23	4,56	4,93	5,32	5,75	6,20	6,70	7,23	7,81
1 000	3,63	3,91	4,23	4,56	4,93	5,32	5,75	6,20	6,70	7,23	7,81	8,43	9,11	9,83
1 250	3,91	4,23	4,56	4,93	5,32	5,75	6,20	6,70	7,23	7,81	8,43	9,11	9,83	10,6
1 600	4,23	4,56	4,93	5,32	5,75	6,20	6,70	7,23	7,81	8,43	9,11	9,83	10,6	11,5
2 000	4,56	4,93	5,32	5,75	6,20	6,70	7,23	7,81	8,43	9,11	9,83	10,6	11,5	12,4
2 500	4,93	5,32	5,75	6,20	6,70	7,23	7,81	8,43	9,11	9,83	10,6	11,5	12,4	13,4
3 200	5,32	5,75	6,20	6,70	7,23	7,81	8,43	9,11	9,83	10,6	11,5	12,4	13,4	14,5
4 000	5,75	6,20	6,70	7,23	7,81	8,43	9,11	9,83	10,6	11,5	12,4	13,4	14,5	15,6
5 000	6,20	6,70	7,23	7,81	8,43	9,11	9,83	10,6	11,5	12,4	13,4	14,5	15,6	16,8
6 300	6,70	7,23	7,81	8,43	9,11	9,83	10,6	11,5	12,4	13,4	14,5	15,6	16,8	18,2
8 000	7,23	7,81	8,43	9,11	9,83	10,6	11,5	12,4	13,4	14,5	15,6	16,8	18,2	19,6
10 000	7,81	8,43	9,11	9,83	10,6	11,5	12,4	13,4	14,5	15,6	16,8	18,2	19,6	21,2
12 500	8,43	9,11	9,83	10,6	11,5	12,4	13,4	14,5	15,6	16,8	18,2	19,6	21,2	22,9
16 000	9,11	9,83	10,6	11,5	12,4	13,4	14,5	15,6	16,8	18,2	19,6	21,2	22,9	24,7
20 000	9,83	10,6	11,5	12,4	13,4	14,5	15,6	16,8	18,2	19,6	21,2	22,9	24,7	26,7
25 000	10,6	11,5	12,4	13,4	14,5	15,6	16,8	18,2	19,6	21,2	22,9	24,7	26,7	28,8
32 000	11,5	12,4	13,4	14,5	15,6	16,8	18,2	19,6	21,2	22,9	24,7	26,7	28,8	31,1
40 000	12,4	13,4	14,5	15,6	16,8	18,2	19,6	21,2	22,9	24,7	26,7	28,8	31,1	-
50 000	13,4	14,5	15,6	16,8	18,2	19,6	21,2	22,9	24,7	26,7	28,8	31,1	-	-
63 000	14,5	15,6	16,8	18,2	19,6	21,2	22,9	24,7	26,7	28,8	31,1	-	-	-
80 000	15,6	16,8	18,2	19,6	21,2	22,9	24,7	26,7	28,8	31,1	-	-	-	-
100 000	16,8	18,2	19,6	21,2	22,9	24,7	26,7	28,8	31,1	-	-	-	-	-
200 000	21,2	22,9	24,7	26,7	28,8	31,1	-	-	-	-	-	-	-	-

C/P ratio in dependence on life  $L_{10h}$  and rotational speed  $n$  for cylindrical roller, spherical roller and tapered roller bearings **Table 3**

Life $L_{10h}$	Rotational speed $n$ [min <sup>-1</sup> ]													
	10	16	25	40	63	100	125	160	200	250	320	400	500	630
h														
100	-	-	-	-	-	-	-	-	1,05	1,1	1,21	1,30	1,39	1,49
500	-	-	-	1,05	1,21	1,39	1,49	1,60	1,71	1,83	1,97	2,11	2,26	2,42
1 000	-	-	1,13	1,30	1,49	1,71	1,83	1,97	2,11	2,26	2,42	2,59	2,78	2,97
1 250	-	1,05	1,21	1,39	1,60	1,83	1,97	2,11	2,26	2,42	2,59	2,78	2,97	3,19
1 600	-	1,13	1,30	1,49	1,71	1,97	2,11	2,26	2,42	2,59	2,78	2,97	3,19	3,42
2 000	1,05	1,21	1,39	1,60	1,83	2,11	2,26	2,42	2,59	2,78	2,97	3,19	3,42	3,66
2 500	1,13	1,30	1,49	1,71	1,97	2,26	2,42	2,59	2,78	2,97	3,19	3,42	3,66	3,92
3 200	1,21	1,39	1,60	1,83	2,11	2,42	2,59	2,78	2,97	3,19	3,42	3,66	3,92	4,20
4 000	1,30	1,49	1,71	1,97	2,26	2,59	2,78	2,97	3,19	3,42	3,66	3,92	4,20	4,50
5 000	1,39	1,60	1,83	2,11	2,42	2,78	2,97	3,19	3,42	3,66	3,92	4,20	4,50	4,82
6 300	1,49	1,71	1,97	2,26	2,59	2,97	3,19	3,42	3,66	3,92	4,20	4,50	4,82	5,17
8 000	1,60	1,83	2,11	2,42	2,78	3,19	3,42	3,66	3,92	4,20	4,50	4,82	5,17	5,54
10 000	1,71	1,97	2,26	2,59	2,97	3,42	3,66	3,92	4,20	4,50	4,82	5,17	5,54	5,94
12 500	1,83	2,11	2,42	2,78	3,19	3,66	3,92	4,20	4,50	4,82	5,17	5,54	5,94	6,36
16 000	1,97	2,26	2,59	2,97	3,42	3,92	4,20	4,50	4,82	5,17	5,54	5,94	6,36	6,81
20 000	2,11	2,42	2,78	3,19	3,66	4,20	4,50	4,82	5,17	5,54	5,94	6,36	6,81	7,30
25 000	2,26	2,59	2,97	3,42	3,92	4,50	4,82	5,17	5,54	5,94	6,36	6,81	7,30	7,82
32 000	2,42	2,78	3,19	3,66	4,20	4,82	5,17	5,54	5,94	6,36	6,81	7,30	7,82	8,38
40 000	2,59	2,97	3,42	3,92	4,50	5,17	5,54	5,94	6,36	6,81	7,30	7,82	8,38	8,98
50 000	2,78	3,19	3,66	4,20	4,82	5,54	5,94	6,36	6,81	7,30	7,82	8,38	8,98	9,62
63 000	2,97	3,42	3,92	4,50	5,17	5,94	6,36	6,81	7,30	7,82	8,38	8,98	9,62	10,3
80 000	3,19	3,66	4,20	4,82	5,54	6,36	6,81	7,30	7,82	8,38	8,98	9,62	10,3	11,0
100 000	3,42	3,92	4,50	5,17	5,94	6,81	7,30	7,82	8,38	8,98	9,62	10,3	11,0	11,8
200 000	4,20	4,82	5,54	6,36	7,30	8,38	8,98	9,62	10,3	11,0	11,8	12,7	13,6	14,6

Life $L_{10h}$	Rotational speed $n$ [min <sup>-1</sup> ]													
	800	1000	1250	1600	2000	2500	3200	4000	5000	6300	8000	10000	12500	16000
h														
100	1,60	1,71	1,83	1,97	2,11	2,26	2,42	2,59	2,78	2,97	3,19	3,42	3,66	3,92
500	2,59	2,78	2,97	3,19	3,42	3,66	3,92	4,20	4,50	4,82	5,17	5,54	5,94	6,36
1 000	3,19	3,42	3,66	3,92	4,20	4,50	4,82	5,17	5,54	5,94	6,36	6,81	7,30	7,82
1 250	3,42	3,66	3,92	4,20	4,50	4,82	5,17	5,54	5,94	6,36	6,81	7,30	7,82	8,38
1 600	3,66	3,92	4,20	4,50	4,82	5,17	5,54	5,94	6,36	6,81	7,30	7,82	8,38	8,98
2 000	3,92	4,20	4,50	4,82	5,17	5,54	5,94	6,36	6,81	7,30	7,82	8,38	8,98	9,62
2 500	4,20	4,50	4,82	5,17	5,54	5,94	6,36	6,81	7,30	7,82	8,38	8,98	9,62	10,3
3 200	4,50	4,82	5,17	5,54	5,94	6,36	6,81	7,30	7,82	8,38	8,98	9,62	10,3	11,0
4 000	4,82	5,17	5,54	5,94	6,36	6,81	7,30	7,82	8,38	8,98	9,62	10,3	11,0	11,8
5 000	5,17	5,54	5,94	6,36	6,81	7,30	7,82	8,38	8,98	9,62	10,3	11,0	11,8	12,7
6 300	5,54	5,94	6,36	6,81	7,30	7,82	8,38	8,98	9,62	10,3	11,0	11,8	12,7	13,6
8 000	5,94	6,36	6,81	7,30	7,82	8,38	8,98	9,62	10,3	11,0	11,8	12,7	13,6	14,6
10 000	6,36	6,81	7,30	7,82	8,38	8,98	9,62	10,3	11,0	11,8	12,7	13,6	14,6	15,6
12 500	6,81	7,30	7,82	8,38	8,98	9,62	10,3	11,0	11,8	12,7	13,6	14,6	15,6	16,7
16 000	7,30	7,82	8,38	8,98	9,62	10,3	11,0	11,8	12,7	13,6	14,6	15,6	16,7	17,9
20 000	7,82	8,38	8,98	9,62	10,3	11,0	11,8	12,7	13,6	14,6	15,6	16,7	17,9	19,2
25 000	8,38	8,98	9,62	10,3	11,0	11,8	12,7	13,6	14,6	15,6	16,7	17,9	19,2	20,6
32 000	8,98	9,62	10,3	11,0	11,8	12,7	13,6	14,6	15,6	16,7	17,9	19,2	20,6	-
40 000	9,62	10,3	11,0	11,8	12,7	13,6	14,6	15,6	16,7	17,9	19,2	20,6	-	-
50 000	10,3	11,0	11,8	12,7	13,6	14,6	15,6	16,7	17,9	19,2	20,6	-	-	-
63 000	11,0	11,8	12,7	13,6	14,6	15,6	16,7	17,9	19,2	20,6	-	-	-	-
80 000	11,8	12,7	13,6	14,6	15,6	16,7	17,9	19,2	20,6	-	-	-	-	-
100 000	12,7	13,6	14,6	15,6	16,7	17,9	19,2	20,6	-	-	-	-	-	-
200 000	15,6	16,7	17,9	19,2	20,6	-	-	-	-	-	-	-	-	-



In arrangements of the axles of road and railway vehicles the nominal life can be expressed by a revised relation in the volume of kilometers travelled.

$$L_{10km} = \left(\frac{C}{P}\right)^p \cdot \frac{\pi D}{1000}$$

$L_{10km}$  - nominal life  
 $D$  - wheel diameter

[10<sup>6</sup>km]  
[m]

### Reference Nominal Life Values

In cases, where the life for a given arrangement is not specified in advance, the values in tables 4 and 5 can be considered as adequate

Reference Nominal Life Values in Operating Hours		Table 4
Machine Type	Nominal Life	
	$L_{10h}$	
	h	
Devices and tools rarely used	1 000	
Household electric appliances, small fans	2 000 to 4 000	
Machines for intermittent operation, hand tools, workshop lifting tackles, agricultural machine	4 000 to 8 000	
Machines with intermittent operation where high reliability is required, auxiliary power station equipment, belt conveyors, trucks, elevators	8 000 to 15 000	
Rolling mills	6 000 to 12 000	
Machines operating 8 - 16 hours - stationary electric motors, gear drives, textile machine spindles, plastic material processing machines, printing machines, cranes	15 000 to 30 000	
Machine tools in general	20 000 to 30 000	
Machines with continuous operation - stationary electric machines, conveying equipment, roller conveyors, pumps, centrifuges, blowers, compressors, hammer mills, crushers, briquetting presses, mine hoists, rope pulleys	40 000 to 60 000	
Machines with continuous operation for high operating reliability - power station plants, water works machinery, paper making machines, ship machines	100 000 to 200 000	

Reference Nominal Life Values in Kilometers		Table 5
Vehicle Type	Nominal Life	
	$L_{10km}$	
	km	
Road vehicle wheels :		
motor cycles	60 000	
passenger cars	150 000 to 250 000	
trucks, buses	400 000 to 500 000	
Axle box bearings for railway vehicles :		
freight wagons (according to UIC) under continuous maximum axle load acting	800 000	
tram cars	1 500 000	
railway passenger carriages	3 000 000	
motor wagons and motor units	3 000 000 to 4 000 000	
locomotives	3 000 000 to 5 000 000	

### Equation of Adjusted Life

Adjusted life is a corrected nominal life, where by calculation not only the load but the influence of bearing components, material, physical, mechanical, and chemical qualities of lubricants and the temperature regime of the bearing the operating environment' are taken into account.

$$L_{na} = a_1 \cdot a_{23} \cdot L_{10}$$

- $L_{na}$  - adjusted life for (100-n)% reliability and other usual operation conditions [10<sup>6</sup> rev]
- $a_1$  - life factor for other than 90% reliability, see Table 6
- $a_{23}$  - life factor of material, lubricant, production technology and operation conditions, see Pict. 1
- $L_{10}$  - nominal life [10<sup>6</sup> rev]

Factor $a_1$ Values		Table 6	
Reliability (%)		$L_n$	$a_1$
90		$L_{10}$	1,00
95		$L_5$	0,62
96		$L_4$	0,53
97		$L_3$	0,44
98		$L_2$	0,33
99		$L_1$	0,21

We can find basic values of  $a_{23}$  by using the diagram in Pict.1.

$$\kappa = \frac{\nu}{\nu_1}$$

$\nu$  - kinematic lubricant viscosity by operation bearing temperature [mm<sup>2</sup>.s<sup>-1</sup>]

$\nu_1$  - kinematic viscosity for defined rotational speed and selected bearing dimensions [mm<sup>2</sup>.s<sup>-1</sup>]

Values  $\nu$  and  $\nu_1$  are determined according to the diagrams in Pict. 23 or 24.

In the diagram, Pict. 1, the line I is valid for radial ball bearings operating in a very clean environment. In other cases the factor  $a_{23}$  is lower, depending on the environment cleanliness, and the decreasing tendency is dependent on the bearing design group in following order:

- angular contact ball bearings
- tapered roller bearings
- cylindrical roller bearings
- double row self-aligning ball bearings
- spherical roller bearings

Line II can be used when stating the factor  $a_{23}$  for spherical roller bearings operating in a dusty environment.

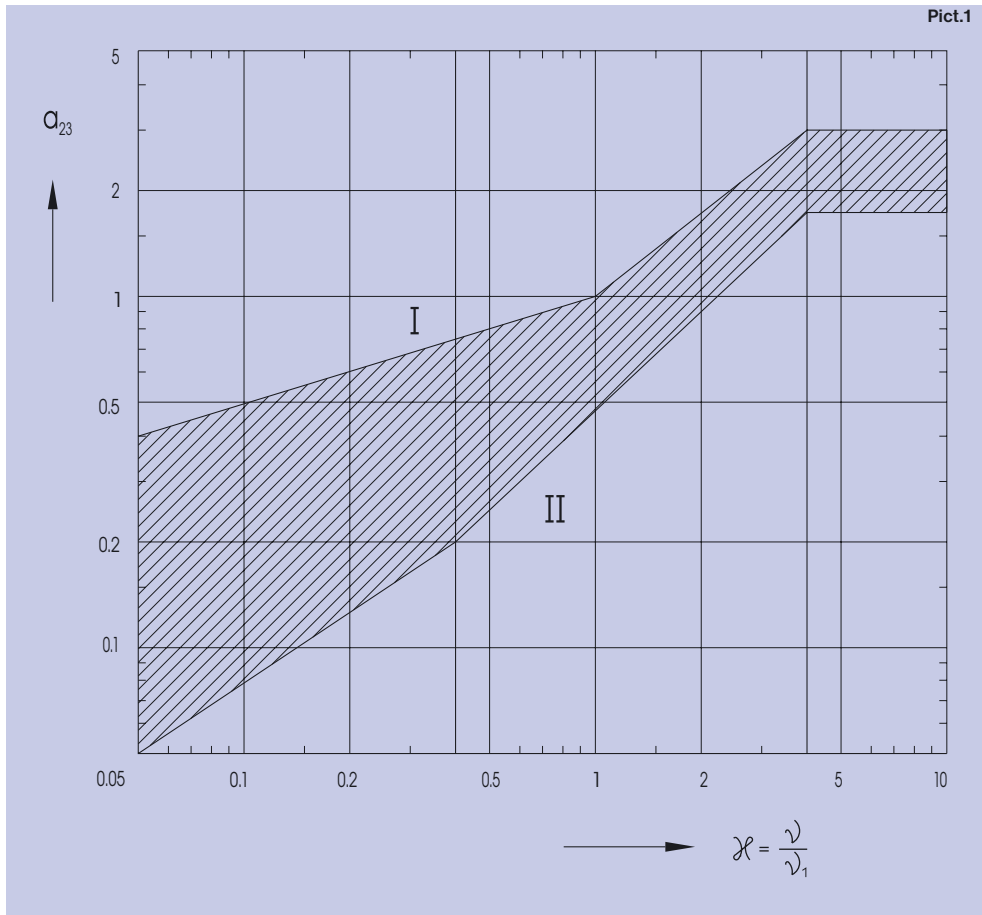

### 1.1.3 Equivalent Dynamic Load

In the arrangement the bearing is subjected to generally acting forces in various magnitudes, at various rotational speeds and with different acting period. From the point of view of calculation methodology the acting forces should be re-calculated into the constant load, by which the bearing will have the same life as it reaches in the conditions of the actual load.

Such a re-calculated constant radial or axial load is called the equivalent load  $P$ , or  $P_r$  (radial) or  $P_a$  (axial).

## Combined Load

### Constant Load

The outer forces acting on a bearing are not changed both from the point of view of size and time dependence.

### Radial Bearings

If the radial bearings are simultaneously subjected to constant forces in radial and axial directions, the following equation is valid for calculating the radial equivalent dynamic load :

$$P_r = X \cdot F_r + Y \cdot F_a \quad [\text{kN}]$$

$P_r$	- radial equivalent dynamic load	[kN]
$F_r$	- radial bearing load	[kN]
$F_a$	- axial bearing load	[kN]
$X$	- radial load factor	
$Y$	- axial load factor	

Factors  $X$  and  $Y$  depend on the ratio  $F_a/F_r$ . Values  $X$  and  $Y$  are shown in the dimension tables or in the introduction to each bearing type where closer information regarding bearing calculation of the respective type is given.

### Thrust Bearings

Thrust ball bearings can carry only forces acting in axial direction and the following equation is valid for calculating axial equivalent dynamic load :

$$P_a = F_a \quad [\text{kN}]$$

$P_a$	- axial equivalent dynamic load	[kN]
$F_a$	- axial bearing load	[kN]

Spherical roller thrust bearings can also carry some radial load, but only by simultaneous acting of axial load, when condition  $F_r \leq 0.55 F_a$  must be fulfilled. Axial equivalent dynamic load is calculated from equation

$$P_a = F_a + 1,2 F_r \quad [\text{kN}]$$

### Fluctuating Load

Real fluctuating load, whose time course we know, is for calculation replaced by mean hypothetical load. This hypothetical load has the same influence on the bearing as the fluctuating load.

### Change of Load Magnitude by Constant Rotational Speed

If the bearing is subjected to a load in a constant direction, whose magnitude is changed in dependence on time and the rotational speed is constant (Pict. 2), we can calculate the mean hypothetical load  $F_s$  according to the following equation

$$F_s = \left( \sum_{i=1}^n F_i^3 \cdot \frac{q_i}{100} \right)^{\frac{1}{3}} \quad [\text{kN}]$$

- $F_s$  - mean hypothetical constant load [kN]
- $F_i = F_1, \dots, F_n$  - partial actual load [kN]
- $q_i = q_1, \dots, q_n$  - share of fractional load effects [%]

At constant rotational speed with linear change of the load in constant direction (Pict. 3) the mean hypothetical load can be calculated from equation

$$F_s = \frac{F_{\min} + 2F_{\max}}{3} \quad [\text{kN}]$$

If the actual load has a sine behaviour (Pict. 4), the mean hypothetical load is

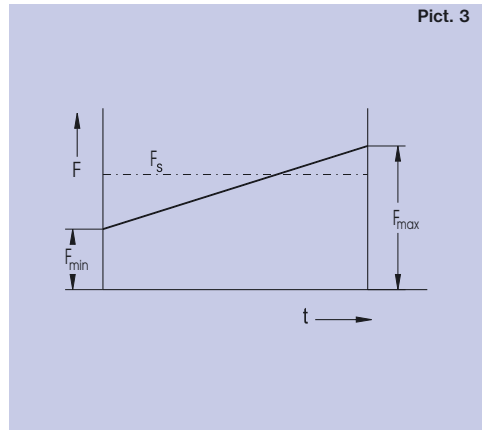
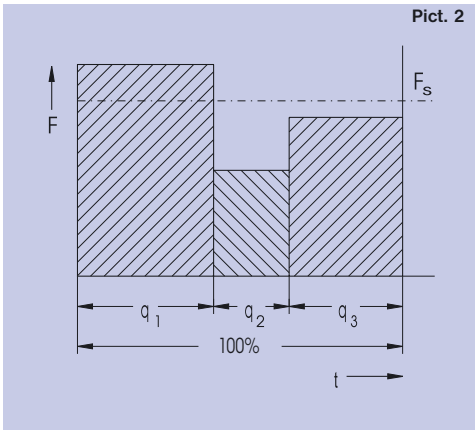

$$F_s = 0,75 \cdot F_{\max} \quad [\text{kN}]$$

### Change of Load Magnitude by Change of Rotational Speed

If the bearing is subjected in time to a varying load and the rotational speed is being changed, the mean hypothetical load is calculated from equation

$$F_s = \left( \frac{\sum_{i=1}^n F_i^3 \cdot q_i \cdot n_i}{\sum_{i=1}^n q_i \cdot n_i} \right)^{\frac{1}{3}} \quad [\text{kN}]$$

- $n_i = n_1, \dots, n_n$  - constant rotational speed in time of partial loads  $F_1, \dots, F_n$  acting [ $\text{min}^{-1}$ ]
- $q_i = q_1, \dots, q_n$  - share of partial load and rotational speed acting [%]

If in dependence on time only the rotational speed is changed, the mean hypothetical constant rotational speed is calculated from equation

$$n_s = \frac{\sum_{i=1}^n q_i \cdot n_i}{100} \quad [\text{min}^{-1}]$$

$n_s$  = mean rotational speed [ $\text{min}^{-1}$ ]

### Oscillating Motion of Bearing

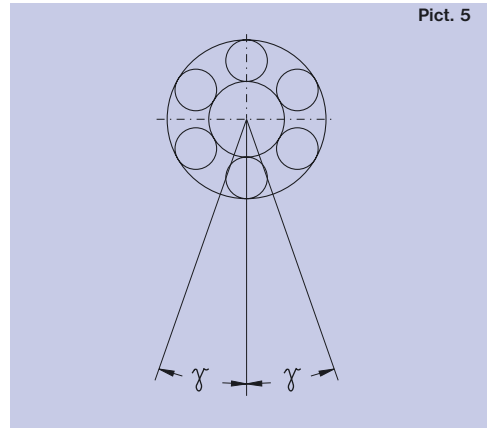
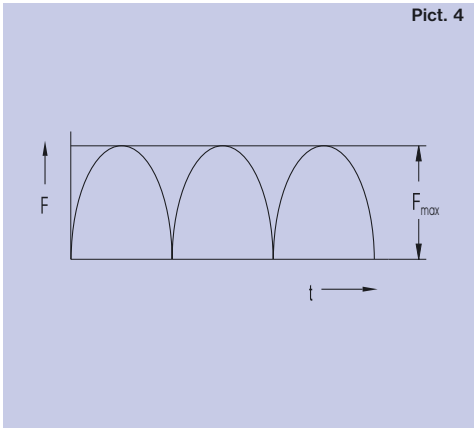

By oscillating motion with amplitude  $\gamma$  (Fig. 5) it is the simplest way of substituting the oscillating motion by hypothetical rotation, when the rotational speed equals the oscillation frequency. For radial bearings the mean hypothetical load is calculated from the equation

$$F_s = F_r \left( \frac{\gamma}{90} \right)^{\frac{1}{p}} \quad [\text{kN}]$$

- $F_s$  - mean hypothetical load [kN]
- $F_r$  - actual radial load [kN]
- $\gamma$  - oscillating motion amplitude [°]
- $p$  - exponent  $p = 3$  for ball bearings

$p = \frac{10}{3}$  for cylindrical roller, needle roller, spherical roller and tapered roller bearings

#### 1.1.4 Temperature Influence

Delivered bearing assortment is determined for usage in an environment with operating temperatures up to 120°C. Exceptions are double row spherical roller bearings which can work at temperatures up to 200°C, and single row ball bearings with seals (RS, 2RS, RSR, 2RSR) applicable up to 110°C, with seals RS2, -2RS2 applicable up to 150°C.

For higher operation temperatures the bearings are produced so that their necessary physical and mechanical qualities and dimensional stability can be secured.

Values of the basic dynamic load ratings  $C_r$  or  $C_a$  shown in the dimension tables of this publication should be multiplied by factor  $f_t$ , shown in Table 7.

Values of $f_t$ Factor		Table 7			
Operating Temperature to [°C]		150	200	250	300
Factor $f_t$		0,95	0,9	0,75	0,6

## 1.2 Static Load

### 1.2.1 Basic Static Load Rating

Radial basic static load rating  $C_{or}$  and axial basic static load rating  $C_{oa}$  are shown for each bearing in the dimension tables of this publication. Values  $C_{or}$  and  $C_{oa}$  were stated by a calculation according to the standard ISO 76.

Basic static load rating is the load which corresponds to calculated contact stresses at the most heavily loaded contact zone of the rolling element and bearing raceway:

- 4600 MP<sub>a</sub> for double row self-aligning ball bearings
- 4 200 MP<sub>a</sub> for the other ball bearings
- 4 000 MP<sub>a</sub> for cylindrical roller, needle roller, spherical roller and tapered roller bearings

### 1.2.2 Equivalent Static Load

Equivalent static load is a re-calculated radial load  $P_{or}$  for radial bearings and axial axis load  $P_{oa}$  for thrust bearings.

$$P_{or} = X_0 F_r + Y_0 F_a \quad [\text{kN}]$$

$$P_{oa} = X_0 F_r + Y_0 F_a \quad [\text{kN}]$$

$P_{or}$  - radial equivalent static load [kN]

$P_{oa}$  - axial equivalent static load [kN]

$F_r$  - radial load [kN]

$F_a$  - axial load [kN]

$X_0$  - radial load factor

$Y_0$  - axial load factor

Factor $s_0$		Table 8	
Bearing motion	Type of load, demands on bearing running	Ball Bearings	$s_0$ Cylindrical roller, needle roller, spherical roller, tapered roller bearings
Rotary	distinct impact load, high demands on smooth running	2	4
	after static loading bearing rotates under smaller load	1.5	3
	normal demands on smooth running		
	normal operating conditions and normal demands on running	1	1.5
	smooth impact-free operating	0.5	1
Oscillating	small oscillation angle with high frequency, with uneven impact loading	2	3.5
	large oscillating angle with low frequency and with approximately constant periodic load	1.5	2.5
Non-rotary	distinct impact load	1.5 to 1	3 to 2
	normal and small load, no special demands on bearing operation	1 to 0.4	2 to 0.8
	spherical roller thrust bearings at all kinds of motions and loads	-	4

Factors  $X_0$  and  $Y_0$  are given for individual bearings in the dimensional tables of this publication. Subsequently, closer data for stating the equivalent static load of given bearing type are also given here.

### 1.2.3 Bearing Safety under Static Load

In practice the bearing safety under static load is found by the ratio  $C_{or}/P_{or}$  or  $C_{oa}/P_{oa}$  and is compared with data in table 8, where the values of least permissible factors  $s_0$  for various operation conditions are shown.

$$s_0 = \frac{C_{or}}{P_{or}} \quad \text{or} \quad \frac{C_{oa}}{P_{oa}}$$

$s_0$	- safety factor under static load	
$C_{or}$	- radial basic static load rating	[kN]
$C_{oa}$	- axial basic static load rating	[kN]
$P_{or}$	- radial equivalent static load or maximum acting impact force $F_{r \max}$ (Pict. 6) under distinct impact load	[kN]
$P_{oa}$	- axial equivalent static load or maximum acting impact force $F_{a \max}$ (Pict. 6) under distinct impact load	[kN]

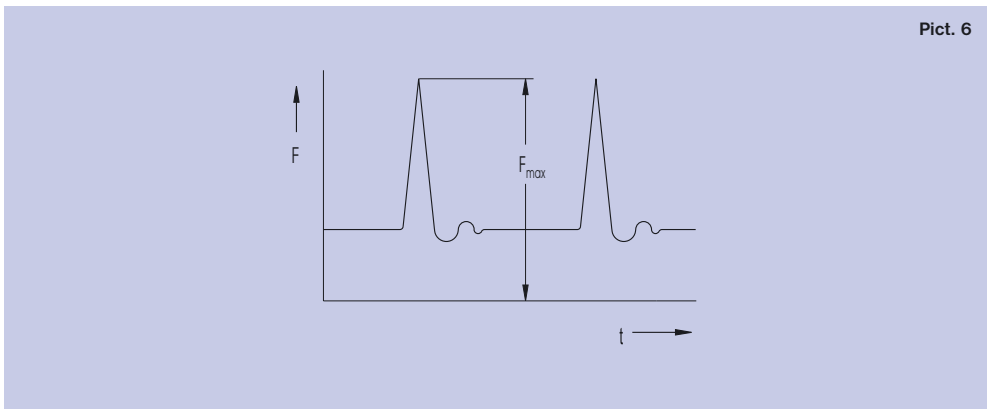

### 1.3 Limiting Speed

Limiting speed depends on the bearing type, its accuracy, cage design, internal clearance, operating conditions in arrangement, kind of lubrication and on other factors. This influence summary determines the heat generation in the bearing and also limited rotational speed which is first of all limited by the lubricant operating temperature.

For orientation, limiting rotational speed values are shown in the dimension tables for individual bearings in normal tolerance class, both for grease and oil lubrication. Given values are valid under presumption of adequate load ( $L_{10h} \geq 100\,000$  h), normal operating conditions and cooling.

It is also necessary to reduce the limiting speed values for radial bearings which are permanently loaded by relatively great axial force. The resulting limiting speed values depend on the ratio of axial and radial load  $F_a/F_r$ .

The shown limiting speed can be exceeded for ball bearings up to 3 times, cylindrical roller bearings up to 2 times, for other bearings except spherical roller and tapered roller bearings up to 1.5 times and for spherical roller bearings 1.3 times.



This exceeding requires:

- adaptation of lubrication and cooling
- higher bearing tolerance class and corresponding accuracy of the abutment parts
- higher radial clearance than normal
- cage of suitable design and material

## 2. Rolling Bearing Design Data

### 2.1 Boundary Dimensions

Bearings introduced in this publication are made in dimensions complying with the international standards ISO 15, ISO 355 and ISO 104.

In the dimensional plan each bearing bore diameter  $d$  corresponds to several outer diameters  $D$  and various widths are added to them -  $B$  or  $T$  for radial and  $H$  for thrust bearings. Bearings having the same bore diameter and outer diameter belong to one diameter series which is designated according to the ascending outer diameter by figures 7,8,9,0,1,2,3,4. Within each diameter series there are bearings of various width series according to the ascending width : 8, 0, 1, 2, 3, 4, 5, 6 for radial bearings and 7,9,1,2 for thrust bearings. Diameter and width series form dimension series which are designated by a two digit number, where the first digit indicates the width series and the second the diameter one, as shown in Pict. 7.

Some standard and special ZKL bearings in 3D visualization will be found on [www.partserver.de](http://www.partserver.de).

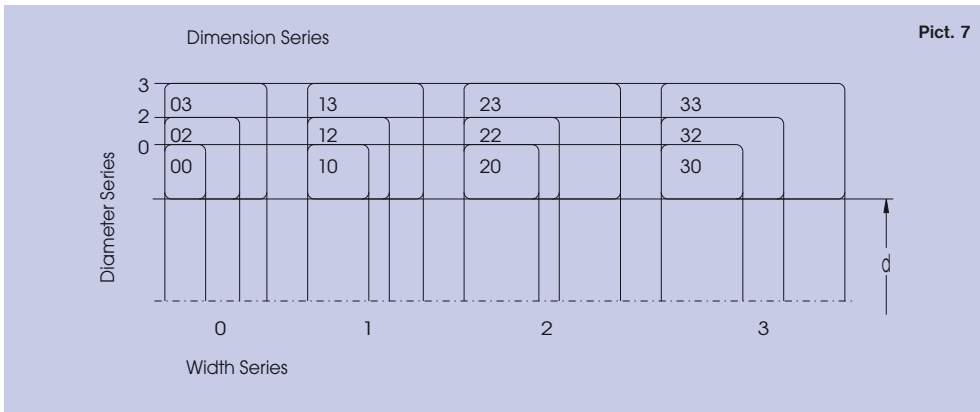

Dimensional plan also includes the bearing ring chamfer dimensions, so called mounting chamfer, see Pict. 8

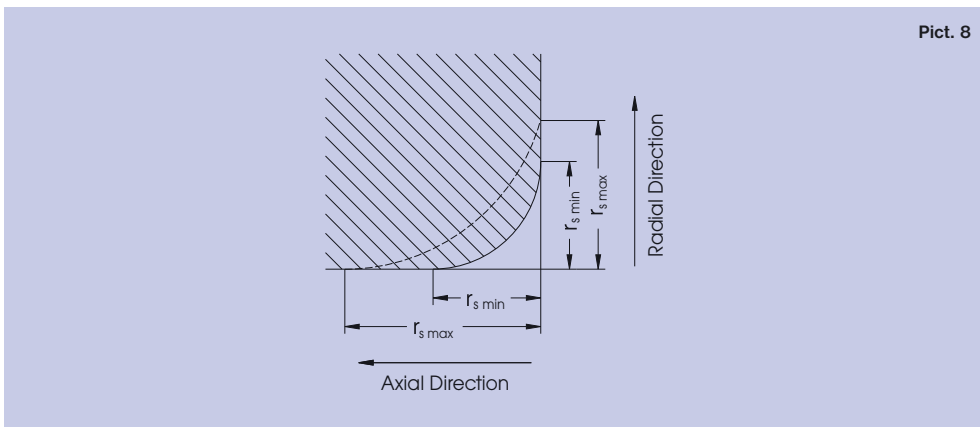

Overview of chamfer limiting values according to international standard ISO 582 is given in Table 9.

Limiting Dimensions of Mounting Chamfer										Table 9
$r_{s \text{ min}}$	Radial Bearings except Tapered Roller Bearings d or D				Tapered Roller Bearings d or D				Thrust Bearings	
	above	to	$r_{s \text{ max}}$ in radial direction	$r_{s \text{ max}}$ in axial direction	above	to	$r_{s \text{ max}}$ in radial direction	$r_{s \text{ max}}$ in axial direction	$r_{s \text{ max}}$ in radial and axial direction	
mm										
0,15	-	-	0,3	0,6	-	-	-	-	0,3	
0,2	-	-	0,5	0,8	-	-	-	-	0,5	
0,3	-	40	0,6	1,0	-	40	0,7	1,4	0,8	
	40	-	0,8	1,0	40	-	0,9	1,6	0,8	
0,6	-	40	1,0	2,0	-	40	1,1	1,7	1,5	
	40	-	1,3	2,0	40	-	1,3	2,0	1,5	
1,0	-	50	1,5	3,0	-	50	1,6	2,5	2,2	
	50	-	1,9	3,0	50	-	1,9	3,0	2,2	
1,1	-	120	2,0	3,5	-	-	-	-	2,7	
	120	-	2,5	4,0	-	-	-	-	2,7	
1,5	-	120	2,3	4,0	-	120	2,3	3,0	3,5	
	120	-	3,0	5,0	120	250	2,8	3,5	3,5	
	-	-	-	-	250	-	3,5	4,0	3,5	
2,0	-	80	3,0	4,5	-	120	2,8	4,0	4,0	
	80	220	3,5	5,0	120	250	3,5	4,5	4,0	
	220	-	3,8	6,0	250	-	4,0	5,0	4,0	
2,1	-	280	4,0	6,5	-	-	-	-	4,5	
	280	-	4,5	7,0	-	-	-	-	4,5	
2,5	-	100	3,8	6,0	-	120	3,5	5,0	-	
	100	280	4,5	6,0	120	250	4,0	5,5	-	
	280	-	5,0	7,0	250	-	4,5	6,0	-	
3,0	-	280	5,0	8,0	-	120	4,0	5,5	5,5	
	280	-	5,5	8,0	120	250	4,5	6,5	5,5	
	-	-	-	-	250	400	5,0	7,0	5,5	
	-	-	-	-	400	-	5,5	7,5	5,5	
4,0	-	-	6,5	9,0	-	120	5,0	7,0	6,5	
	-	-	-	-	120	250	5,5	7,5	6,5	
	-	-	-	-	250	400	6,0	8,0	6,5	
	-	-	-	-	400	-	6,5	8,5	6,5	
5,0	-	-	8,0	10,0	-	180	6,5	8,0	8,0	
	-	-	-	-	180	-	7,5	9,0	8,0	
6,0	-	-	10,0	13,0	-	180	7,5	10,0	10,0	
	-	-	-	-	180	-	9,0	11,0	10,0	
7,5	-	-	12,5	17,0	-	-	-	-	12,5	
9,5	-	-	15,0	19,0	-	-	-	-	15,0	
12,0	-	-	18,0	24,0	-	-	-	-	18,0	
15,0	-	-	21,0	30,0	-	-	-	-	21,0	

## 2.2 Designation

Bearing designation is created by numerical and letter symbols indicating the type, size and design of the bearing, see the scheme.

In the basic design the bearings are designated by a basic designation which consists of bearing type and size designation. The type designation is usually created by the symbol indicating the bearing design (see position 3 in the scheme) and the symbol for dimension series or diameter series (positions 4 and 5 in the scheme), e.g. bearing type 223, 302, NJ22, 511, 62, 12, etc. Bearing size designation is created by symbols for the nominal bore diameter d [see position 6 in the scheme].

### Bearings with bore diameter $d < 10$ mm:

Digit separated by a slash, or the last digit indicates directly the bore dimension in mm, e.g. 619/2, 624.

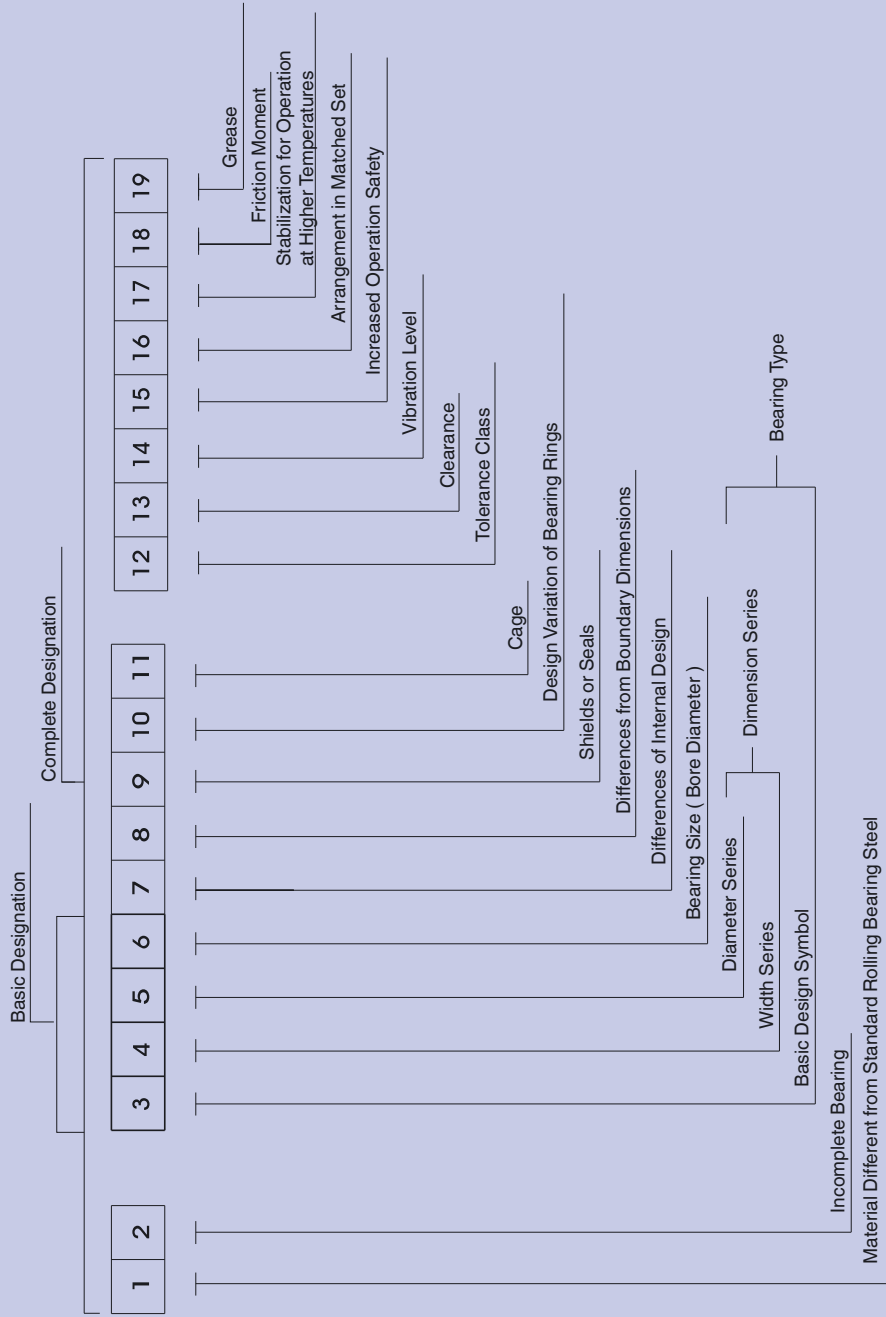

### Bearings with bore diameter $d = 10$ to $17$ mm :

double digit number	00 indicates bore	$d = 10$ mm,	e.g. 6200
	01	$d = 12$ mm,	e.g. 51101
	02	$d = 15$ mm,	e.g. 3202
	03	$d = 17$ mm,	e.g. 6303

An exception to the designation are separable single row ball bearings - types E and B0, where the double digit number indicates directly the bore diameter in mm, e.g. E17.

### Bearings with bore diameter $d = 20$ to $480$ mm :

Bore diameter is a fivefold of the last double digit number, e.g. bearing 1320 has the bore diameter  $d = 20 \times 5 = 100$ .

An exception create bearings with bore  $d = 22, 28,$  and  $32$  mm, where the double digit number separated by a slash indicates directly the bore diameter in mm, e.g. 320/32AX, further separable single row ball bearings - type E and single row cylindrical roller bearings - type NG, where the double digit number, or number indicates directly the bore diameter in mm, e.g. : E20, NG160 C450.

### Bearings with bore diameter $d > 500$ mm:

The last three or four digit number separated by a slash indicates directly the bore diameter in mm, e.g. 230/530M, NU29/1060.

Bearings produced in different design than standard are designated by so called complete designation, see the scheme. It consists of the basic designation and prefixes and suffixes indicating the difference from the basic design.

### Meaning of Prefixes and Suffixes

In compliance with complete designation a survey and meaning of used prefixes and suffixes is given in the following part. (Number in brackets at individual groups corresponds to the position number in the scheme).

### Prefixes

#### Material Different from Standard Bearing Steel (1)

- C - ceramic balls, e.g. C B7006CTA
- X - corrosion resisting steel, e.g. X 623
- T - case hardened steel, e.g. T 32240

#### Incomplete Bearing (2)

- L - removable ring of separable bearing, e.g. L NU206, for thrust ball bearings without shaft washer, e.g. L 51215
- R - separable bearing without removable ring, e.g. R NU206 or R N310
- E - single shaft washer of thrust roller bearing, e.g. E 51314
- W - single housing washer of thrust ball bearing, e.g. W 51411
- K - cage with rolling elements, e.g. K NU320

### Suffixes

#### Difference of Internal Design (7)

- A - single row angular contact ball bearing, contact angle  $\alpha = 25^\circ$ , e.g. B7205ATB P5  
single row tapered roller bearing with higher load rating and higher limiting speed, e.g. 30206A  
thrust ball bearing with higher limiting speed, e.g. 51105A
- AA - single row angular contact ball bearing with contact angle  $\alpha = 26^\circ$ , e.g. B72010AATB P4
- B - single row angular contact ball bearing with contact angle  $\alpha = 40^\circ$ , e.g. 7304B  
single row tapered roller bearing with contact angle  $\alpha > 17^\circ$ , e.g. 32315B
- BE - single row angular contact ball bearing with contact angle  $\alpha = 40^\circ$ , in new design, e.g. 7310BETNG
- C - Single row angular contact ball bearing with contact angle  $\alpha = 15^\circ$ , e.g. B7202CTB P4  
double row spherical roller bearing in new design, e.g. 22216C

- CA - single row angular contact ball bearing with contact angle  $\alpha = 12^\circ$ , e.g. B7202CATB P5
- CB - single row angular contact ball bearing with contact angle  $\alpha = 10^\circ$ , e.g. B7206CBTB P4
- CC - double row spherical roller bearing in new design, e.g. Z3996CCM
- D - single row ball bearing - type 160 with higher load rating, e.g. 16004D
- E - single row cylindrical roller bearing with higher load rating, e.g. NU209E  
double row spherical roller bearing with higher load rating, e.g. Z2215E  
spherical roller thrust bearing with higher load rating, e.g. Z9416EJ

### Difference of Boundary Dimensions

- X - change of boundary dimensions, introduced by new international standards, e.g. 32028AX

### Shields or Seals

- RS - seal on one side, e.g. 6304RS
- 2RS - seals on both sides, e.g. 6204-2RS
- RSN - seal on one side and snap ring groove in outer ring opposite to seal side, e.g. 6306RSN
- RSNB - seal on one side and snap ring groove in outer ring on the same side as seal, e.g. 6210RSNB
- 2RSN - seals on both sides and snap ring groove in outer ring, e.g. 6310-2RSN
- RSR - seal on one side adhering to flat surface of inner ring, e.g. 624RSR
- 2RSR - seals on both sides adhering to flat surface of inner ring, e.g. 608-2RSR
- Z - metal shield on one side, e.g. 6206Z
- ZZ - metal shields on both sides, e.g. 6304-ZZ
- ZN - metal shield on one side and snap ring groove in outer ring opposite to metal shield, e.g. 6208ZN
- ZNB - metal shield on one side and snap ring groove in outer ring on the same side as shield, e.g. 6306ZNB
- ZZN - metal shields on both sides and snap ring groove in outer ring, e.g. 6208-ZZN
- ZR - metal shield on one side adhering to flat surface of inner ring, e.g. 608ZR
- ZZR - metal shields on both sides adhering to flat surface of inner ring, e.g. 608-ZZR

### Bearing Ring Design Variation (10)

- K - tapered bore, taper 1:12, e.g. 1207K
- K30 - tapered bore, taper 1:30, e.g. 24064K30M
- N - snap ring groove in outer ring, e.g. 6308N
- NR - snap ring groove in outer ring and inserted snap ring, e.g. 6310NR
- NX - snap ring groove in outer ring whose boundary dimensions do not correspond to 02 4605, e.g. 6210NX
- O - split inner ring, e.g. 3309D
- W33 - groove and lubrication holes in bearing outer ring surface, e.g. 23148W33M
- O - lubrication grooves in bearing outer ring, e.g. NU1014D

### Cages (11)

Cage material for bearings in basic design is not usually indicated.

- EMH - one piece machined brass cage guided on the inner ring
- EMHD2 - one piece machined brass cage guided on the outer ring
- J - pressed steel cage, rolling element centred, e.g. 6034J
- J2 - pressed steel cage, rolling element centred, new design for single row tapered roller bearings, e.g. 30206AJ2
- Y - pressed brass cage, rolling elements centred, e.g. 6001Y
- F - machined steel cage, rolling elements centred, e.g. 6418F
- L - machined light metal cage, rolling elements centred, e.g. NG180L C3S0
- M - machined brass or bronze cage, rolling elements centred, e.g. NU330M

- T - machined cage made of textite, rolling elements centred, e.g. 6005T P5
- TN - machined cage made of polyamide or similar plastic, rolling elements centred, e.g. 6207TN
- TNG - machined cage made of polyamide or similar plastic with glass fibres, rolling elements centred, e.g. 2305TNG

Cage design (introduced symbols are always used in connection with cage material symbols).

- A - cage centred on outer ring, e.g. NU226MA
- B - cage centred on inner ring, e.g. B7204CATBP5
- P - machined window-type cage, e.g. NU1060MAP
- H - one-piece open-type cage, e.g. 629TNH
- S - cage with lubrication grooves, e.g. NJ418MAS
- V - bearing without cage, full rolling element number, e.g. NU209V

### **Tolerance Class (12)**

- P0 - standard tolerance class (not indicated), e.g. 6204
- P6 - higher tolerance class than standard, e.g. 6322 P6
- P5 - higher tolerance class than P6, e.g. 6201 P5
- PSA - in some parameters higher tolerance class than P5, e.g. 6006TB P5A
- P4 - higher tolerance class than P5, e.g. B7204CBTB P4
- P4A - in some parameters higher tolerance class than P4, e.g. B7205CATB P4A
- P2 - higher tolerance class than P4, e.g. B7205CATB P2
- P6E - higher tolerance class for rotating electric machines, e.g. 6204 P6E
- P6X - higher tolerance class for single row tapered roller bearings, e.g. 30210A P6X
- SP - higher tolerance class for cylindrical roller bearings with tapered bore, e.g. NN3022K SPC2NA
- UP - higher tolerance class than SP for cylindrical roller bearings with tapered bore, e.g. N1016 UPC1NA

### **Clearances (13)**

- C2 - clearance less than normal, e.g. 608 C2  
normal clearance (not indicated), e.g. 6204
- C3 - clearance greater than normal, e.g. 6310 C3
- C4 - clearance greater than C3, e.g. NU320M C4
- C5 - clearance greater than C4, e.g. 22330M C5
- NA - radial clearance for bearings with non-interchangeable rings (always after radial clearance symbol), e.g. NU215 P63NA
- R... - radial clearance in non-standardized range (range in  $\mu\text{m}$ ), e.g. 6210A R10-20
- A... - axial clearance in non-standardized range (range in  $\mu\text{m}$ ), e.g. 3210 A20-30

### Vibration Level (14)

C6 - reduced vibration level lower than normal (not indicated) e.g. 6304 C6

C06 - reduced vibration level lower than C6, e.g. 6205 C06

C66 - reduced vibration level lower than C06, e.g. 6205 C66

Concrete C06 and C66 values are determined after negotiations between customer and supplier.

Note: Bearings in tolerance class P5 and higher have vibration level C6.

### Increased Operation Safety

C7, C8, C9 - bearings with increased operation safety determined primarily for aircraft industry,  
e.g. 16008 C8

### Symbol Combination (12-15)

Symbols for tolerance class, bearing internal clearances, vibration levels and increased operation safety are combined, when symbol C is omitted from the second and following special bearing characteristics, e.g.:

P6 + C3 = P63	e.g. 6211 P63
P6 + C8 = P68	e.g. 16002 P68
C3 + C6 = C36	e.g. 6303-2RS C36
P5 + C3 + C9 = P539	e.g. 6205MA P539
P6 + C2NA + C6 = P626NA	e.g. NU1038 P626NA

### Bearing Arrangement in Matched Set (16)

Designation of the arrangement in matched sets of two, three or four bearings consists of symbols indicating the bearing arrangement and symbols determining internal clearance, or preload of matched bearings.

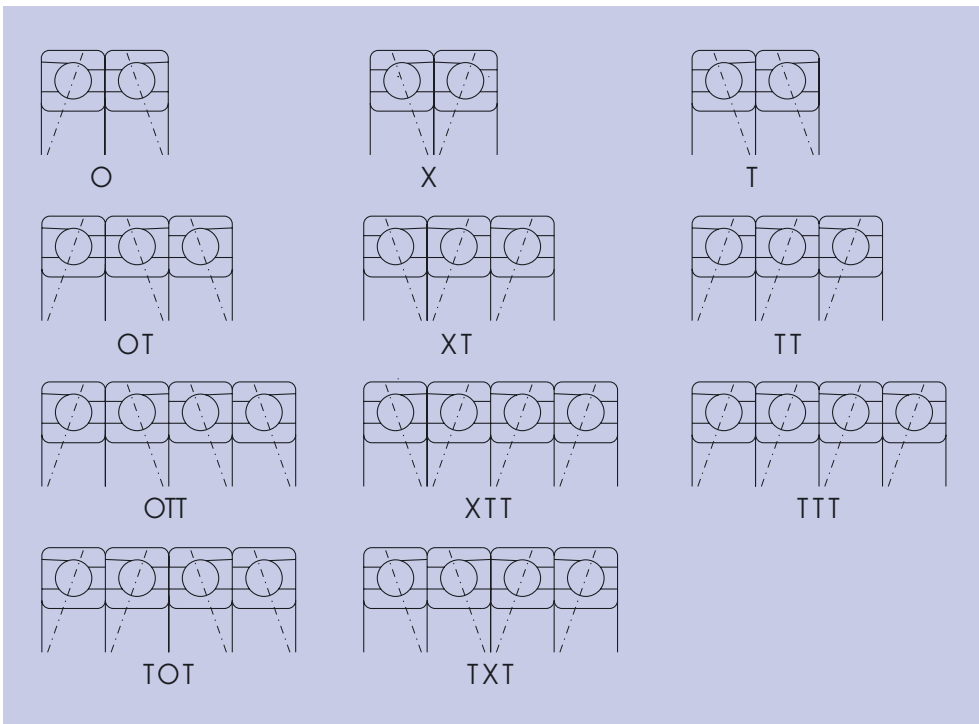

Besides symbols shown in the table also U symbol is used and it indicates that respective bearings can be universally matched, e. g. B7003CTA P4UL.

### Internal Clearance or Preload

Introduced symbols are always used in combination with matching symbols.

- A – bearing matching with clearance, e.g. 73050A
- O – bearing matching without clearance, e.g. 7305 P6XO
- L – bearing matching with light preload, e.g. B7205CATB P4UL
- M – bearing matching with medium preload, e.g. B7204CATB P5XM
- S – bearing matching with great preload, e.g. B7304AATB P40S

### Stabilization for Operation at Higher Temperature

Both rings have stabilized dimensions for operation at higher temperature

- |                              |              |
|------------------------------|--------------|
| S0 for operating temperature | up to 150 °C |
| S1                           | up to 200 °C |
| S2                           | up to 250 °C |
| S3                           | up to 300 °C |
| S4                           | up to 350 °C |
| S5                           | up to 400 °C |

Designation example - NG160LB C4S3.

### Friction Moment (18)

- JU – reduced friction moment, e.g. 619/2 JU
- JUA – bearings with determined friction moment for starting up, e.g. 623 JUA
- JUB – bearings with determined friction moment for running out, e.g. 623 JUB

### Grease (19)

For designation of bearings with shields or seals on both sides, filled with grease different from the standard one, symbol combinations are used for designation. The first two symbols determine the operating temperature range and the third (a letter) the name or type of lubricant, according to producer's prescription, or another symbol (a digit) determines the grease volume, which the sealed or shielded inner bearing's space is filled with.

- TL – grease for low operating temperatures from -60°C to +100°C,  
designation example 6302-2RS TL
  - TM – grease for medium operating temperatures from -35°C to +140°C,  
designation example 6204-2ZR TM
  - TH – grease for high operating temperatures from -30°C to +200°C,  
designation example 6202-2Z TH
  - TW – grease for both low and high operating temperatures from -40°C to +150°C,  
designation example 6310-2Z C4TW
- Note: Symbol TM need not be marked on bearings and packages.

### Bearings according to Special Technical Terms

- TPF – bearings produced according to special technical conditions agreed with the customer,  
e.g. bearing 6205MA P66 according to special technical conditions TPF 11142-71 is designated: 6205MA P66 TPF142
- TPF 99 – double row spherical roller bearing for arrangements of railway vehicle axles,  
e.g. 23234 C3 TPF99
- TPF204 – single row ball bearings for fitting in kiln car wheels, etc., e.g. 6308 TPF204
- TPFK – bearings according to special technical conditions agreed with the customer, which have a great number of symbols indicating variations from the basic design.

In this case only the designation TPF., is given, e.g. bearing NU1015, produced according to technical conditions TPK 11137-70 is designated NU1015 TPK137.



## Bearings according to Special Drawing Documentation PLC PLC A-BC-DE-F designation structure

PLC – symbol for special rolling bearing

A – design group

0 – single row ball bearings

1 – double row ball bearings

2 – thrust ball bearings

3 – not occupied

4 – single row cylindrical roller, spherical roller and needle roller bearings

5 – double and multi-row cylindrical roller, spherical roller and needle roller bearings

6 – single, double and four-row tapered roller bearings

7 – special double row bearings

8 – assembly units and separate parts

9 – thrust cylindrical roller, spherical roller, tapered roller and needle roller bearings

BC – dimensional group - two digit symbols

DE – series number in dimensional group - two digit symbols

F – variation of design - one digit symbol

### 2.3 Tolerance

Under bearing tolerance, dimension and operation accuracy is understood. Bearings are manufactured in tolerance classes P0, P6, P5A, P4, P4A, P2, SP and UP.

Tolerance class P0 is the basic one and a decreasing number in designation means the higher bearing tolerance class. Limiting values for dimension and operation accuracy shown in tables 20 to 30 comply with the standard ISO 492 and ISO 199 (D2 4612). Designation P5A and P4A are used for bearings manufactured in corresponding tolerance class (P5, P4), or selected parameters are in higher tolerance class than P5 and P4.

#### Tolerance Symbols and Their Meaning

$d$  nominal bore diameter

$d_1$  nominal diameter of larger theoretical tapered bore diameter

$d_2$  nominal diameter of shaft washer of double direction thrust bearings

$\Delta_{ds}$  deviation of single bore diameter from nominal

$\Delta_{dmp}$  mean cylindrical bore diameter deviation in single radial plane  
(for tapered bore  $\Delta_{dmp}$  is valid for theoretical bore diameter)

$\Delta_{d1mp}$  deviation of mean larger theoretical diameter of tapered bore

$\Delta_{d2mp}$  mean shaft washer bore diameter deviation of double direction  
thrust bearings in single radial plane

$V_{dp}$  single bore diameter variation in single radial plane

$V_{dmp}$  mean cylindrical bore diameter variation

$V_{d2p}$  shaft washer bore diameter variation of double direction thrust bearings  
in single radial plane

$D$  nominal outside diameter

$\Delta_{Ds}$  deviation of single outside diameter from the nominal dimension

$\Delta_{Dmp}$  mean outside cylindrical surface diameter deviation in single plane

$V_{Dp}$  single outside cylindrical surface diameter variation in single radial plane

$V_{Dmp}$  mean outside cylindrical surface diameter variation

$B$  inner ring nominal width

$T$  total nominal width of tapered roller bearings

$T_1$  nominal effective width of cup sub-unit

$T_2$  nominal effective width of cone sub-unit

$\Delta_{Bs}$  inner ring single width deviation

$\Delta_{Cs}$  outer ring single width deviation

$\Delta_{Ts}$  bearing single width deviation (total)

$\Delta_{T1s}$  cone sub-unit effective width deviation

$\Delta_{T2s}$  cup sub-unit effective width deviation

$C$  outer ring nominal width

$V_{Bs}$	inner ring single width variation
$V_{Es}$	outer ring single width variation
$K_{ia}$	radial runout of assembled bearing inner ring
$K_{ea}$	radial runout of assembled bearing outer ring
$S_i$	shaft washer raceway axial runout
$S_e$	housing washer raceway axial runout
$S_{ia}$	inner ring flat seat face axial runout of assembled bearing
$S_{ea}$	outer ring flat seat face axial runout of assembled bearing
$S_d$	flat seat face axial runout
$S_o$	runout of outside cylindrical surface towards outer ring face
$S_s$	runout of supporting face towards seat face for single row tapered roller bearings.

**Dimension and Running Accuracy of Radial Bearings (except Tapered Roller Bearings)  
Tolerance Class P0**

**Inner Ring**

**Table 10**

d		Cylindrical Bore									Tapered Bore				
		$\Delta_{dmp}$	$V_{Dp}$ Diameter Series 7,8,9 0,1 2,3,4				$V_{dmp}$	$K_{la}$	$\Delta_{Bs}$	$V_{Bs}$	$\Delta_{dmp}$	$\Delta_{d1mp}$	$-\Delta_{dmp}$	$V_{dp}^{(1)}$	
over	to	max	min	max	max	max	max	max	min	max	max	min	max	max	
mm		$\mu m$													
2,5	10	0	-8	10	8	6	6	10	0	-120	15	-	-	-	-
10	18	0	-8	10	8	6	6	10	0	-120	20	-	-	-	-
18	30	0	-10	13	10	8	8	13	0	-120	20	+21	0	+21	0
30	50	0	-12	15	12	9	9	15	0	-120	20	+25	0	+25	0
50	80	0	-15	19	19	11	11	20	0	-150	25	+30	0	+30	0
80	120	0	-20	25	25	15	15	25	0	200	25	+35	0	+35	0
120	180	0	-25	31	31	19	19	30	0	-250	30	+40	0	+40	0
180	250	0	-30	38	38	23	23	40	0	-300	30	+46	0	+46	0
250	315	0	-35	44	44	26	26	50	0	-350	35	+52	0	+52	0
315	400	0	-40	50	50	30	30	60	0	-400	40	+57	0	+57	0
400	500	0	-45	56	56	34	34	65	0	-450	50	+63	0	+63	0
500	630	0	-50	63	63	38	38	70	0	-500	60	-	-	-	-
630	800	0	-75	-	-	-	-	80	0	-750	70	-	-	-	-
800	1000	0	-100	-	-	-	-	90	0	-1000	80	-	-	-	-
1000	1250	0	-125	-	-	-	-	100	0	-1250	100	-	-	-	-

**Outer Ring**

D		$V_{DP}$ Diameter Series 7,8,9 0,1 2,3,4 bearings <sup>2)</sup> with seals									$\Delta_{Cs}, \Delta_{Cs}$	
		$\Delta_{Dmp}$	min	max	max	max	max	max	max	max	max	
over	to	max	min	max	max	max	max	max	max	max	max	
mm		$\mu m$										
6	18	0	-8	10	8	6	10	6	15			
18	30	0	-9	12	9	7	12	7	15			
30	50	0	-11	14	11	8	16	8	20			
50	80	0	-13	16	13	10	20	10	25			
80	120	0	-15	19	19	11	26	11	35			
120	150	0	-18	23	23	14	30	14	40			
150	180	0	-25	31	31	19	38	19	45			
180	250	0	-30	38	38	23	-	23	50			
250	315	0	-35	44	44	26	-	26	60			
315	400	0	-40	50	50	30	-	30	70			
400	500	0	-45	56	56	34	-	34	80			
500	630	0	-50	63	63	38	-	38	100			
630	800	0	-75	94	94	55	-	55	120			
800	1000	0	-100	125	125	75	-	75	140			
1000	1250	0	-125	-	-	-	-	-	160			
1250	1600	0	-160	-	-	-	-	-	190			

Corresponds to  $\Delta_{Bs}, V_{Bs}$  of the same bearing inner ring

1) Valid in any bore radial plane  
2) Valid only for bearings in diameter series 2, 3 and 4

**Dimension and Running Accuracy of Radial Bearings (except Tapered Roller Bearings)  
Tolerance Class P6**

**Table 11**

**Inner Ring**

d over	to	$\Delta_{dmp}$		$V_{dp}$ Diameter Series 7,8,9 0,1 2,3,4				$V_{dmp}$	$K_{ia}$	$\Delta_{Bs}$	$V_{Bs}$	
		max	min	max	max	max	max	max	max	max	min	max
mm		$\mu m$										
2,5	10	0	-7	9	7	5	5	6	0	-120	15	
10	18	0	-7	9	7	5	5	7	0	-120	20	
18	30	0	-8	10	8	6	6	8	0	-120	20	
30	50	0	-10	13	10	8	8	10	0	-120	20	
50	80	0	-12	15	15	9	9	10	0	-150	25	
80	120	0	-15	19	19	11	11	13	0	-200	25	
120	180	0	-18	23	23	14	14	18	0	-250	30	
180	250	0	-22	28	28	17	17	20	0	-300	30	
250	315	0	-25	31	31	19	19	25	0	-350	35	
315	400	0	-30	38	38	23	23	30	0	-400	40	
400	500	0	-35	44	44	26	26	35	0	-450	45	
500	630	0	-40	50	50	30	30	40	0	-500	50	

**Outer Ring**

D over	to	$\Delta_{Dmp}$		$V_{Dp}$ Diameter Series 7,8,9 0,1 2,3,4 bearings <sup>1)</sup> with seals				$V_{Dmp}$	$K_{ea}$	$\Delta_{Cs}$	$V_{Cs}$	
		max	min	max	max	max	max	max	max	max	max	
mm		$\mu m$										
6	18	0	-7	9	7	5	9	5	8			
18	30	0	-8	10	8	6	10	6	9			
30	50	0	-9	11	9	7	13	7	10			
50	80	0	-11	14	11	8	16	8	13			
80	120	0	-13	16	16	10	20	10	18			
120	150	0	-15	19	19	11	25	11	20			
150	180	0	-18	23	23	14	30	14	23			
180	250	0	-20	25	25	15	-	15	25			
250	315	0	-25	31	31	19	-	19	30			
315	400	0	-28	35	35	21	-	21	35			
400	500	0	-33	41	41	25	-	25	40			
500	630	0	-38	48	48	29	-	29	50			
630	800	0	-45	56	56	34	-	34	60			
800	1000	0	-50	75	75	45	-	45	75			

Corresponds to  $\Delta_{Bs}$ ,  $V_{Bs}$  of the same bearing inner ring

1) Valid only for bearings in diameter series 0,1,2, 3 and 4

**Dimension and Running Accuracy of Radial Bearings (except Tapered Roller Bearings)  
Tolerance Class P5**

**Inner Ring**

**Table 12**

d		$\Delta_{dmp}$		$V_{dp}$ Diameter Series <sup>2)</sup>		$V_{dmp}$	$K_{ia}$	$S_d$	$S_{ia}^{1)}$	$\Delta_{Bs}$	$V_{Bs}$	
over	to	max	min	7,8,9 max	0,1,2,3,4 max	max	max	max	max	max	min	max
mm		$\mu\text{m}$										
2,5	10	0	-5	5	4	3	4	7	7	0	-40	5
10	18	0	-5	5	4	3	4	7	7	0	-80	5
18	30	0	-6	6	5	3	4	8	8	0	-120	5
30	50	0	-8	8	6	4	5	8	8	0	-120	5
50	80	0	-9	9	7	5	5	8	8	0	-150	6
80	120	0	-10	10	8	5	6	9	9	0	-200	7
120	180	0	-13	13	10	7	8	10	10	0	-250	8
180	250	0	-15	15	12	8	10	11	13	0	-300	10
250	315	0	-18	18	14	9	13	13	15	0	-350	13
315	400	0	-23	23	18	12	15	15	20	0	-400	15

**Outer Ring**

D		$\Delta_{Dmp}$		$V_{dp}$ Diameter Series <sup>2)</sup>		$V_{Dmp}$	$K_{ea}$	$S_D$	$S_{ea}^{1)}$	$\Delta_{Ca}$	$V_{Ca}$	
over	to	max	min	7,8,9 max	0,1,2,3,4 max	max	max	max	max		max	
mm		$\mu\text{m}$										
6	18	0	-5	5	4	3	5	8	8	Corresponds to $\Delta_{Bs}$ of the same bearing inner ring	5	
18	30	0	-6	6	5	3	6	8	8		5	
30	50	0	-7	7	5	4	7	8	8		5	
50	80	0	-9	9	8	5	8	8	10		6	
80	120	0	-10	10	8	5	10	9	11		8	
120	150	0	-11	11	8	6	11	10	13		8	
150	180	0	-13	13	10	7	13	10	14		8	
180	250	0	-15	15	11	8	15	11	15		10	
250	315	0	-18	18	14	9	18	13	18		11	
315	400	0	-20	20	15	10	20	13	20		13	
400	500	0	-23	23	17	12	23	15	23		15	
500	630	0	-28	28	21	14	25	18	25		18	
630	800	0	-35	35	26	18	30	20	30		20	

1) Valid only for ball bearings

2) Not valid for shielded or sealed bearings

**Dimension and Running Accuracy of Radial Bearings (except Tapered Roller Bearings)  
Tolerance Class P4**

**Inner Ring**

**Table 13**

d over to	$\Delta_{dmp}$		$\Delta_{ds}^{1)}$		$V_{dp}$ Diameter Series 7,8,9 0,1,2,3,4		$V_{dmp}$	$K_{ia}$	$S_d$	$S_{ia}^{2)}$	$\Delta_{Bs}$	$V_{Bs}$	
	max	min	max	min	max	max							
mm	$\mu m$												
2,5 10	0	-4	0	-4	4	3	2,0	2,5	3	3	0	-40	2,5
10 18	0	-4	0	-4	4	3	2,0	2,5	3	3	0	-80	2,5
18 30	0	-5	0	-5	5	4	2,5	3,0	4	4	0	-120	2,5
30 50	0	-6	0	-6	6	5	3,0	4,0	4	4	0	-120	3,0
50 80	0	-7	0	-7	7	5	3,5	4,0	5	5	0	-150	4,0
80 120	0	-8	0	-8	8	6	4,0	5,0	5	5	0	-200	4,0
120 180	0	-10	0	-10	10	8	5,0	6,0	6	7	0	-250	5,0
180 250	0	-12	0	-12	12	9	6,0	8,0	7	8	0	-300	6,0

**Outer Ring**

D over to	$\Delta_{Dmp}$		$V_{Ds1)}$		$V_{Dp}$ Diameter Series <sup>3)</sup> 7,8,9 0,1,2,3,4		$V_{Dmp}$	$K_{ea}$	$S_D$	$S_{ea}^{2)}$	$\Delta_{Cs}$	$V_{Cs}$
	max	min	max	min	max	max						
mm	$\mu m$											
6 18	0	-4	0	-4	4	3	2,0	3	4	5	Corresponds to $\Delta_{Bs}$ of the same bearing inner ring	2,5
18 30	0	-5	0	-5	5	4	2,5	4	4	5		2,5
30 50	0	-6	0	-6	6	5	3,0	5	4	5		2,5
50 80	0	-7	0	-7	7	5	3,5	5	4	5		3,0
80 120	0	-8	0	-8	8	6	4,0	6	5	6		4,0
120 150	0	-9	0	-9	9	7	5,0	7	5	7		5,0
150 180	0	-10	0	-10	10	8	5,0	8	5	8		5,0
180 250	0	-11	0	-11	11	8	6,0	10	7	10		7,0
250 315	0	-13	0	-13	13	10	7,0	11	8	10		7,0
315 400	0	-15	0	-15	15	11	8,0	13	10	13		8,0

1) Valid only for bearings with diameter series 0, 1, 2, 3 and 4

2) Valid only for ball bearings

3) Not valid for shielded or sealed bearings

**Dimension and Running Accuracy of Cylindrical Roller Bearings with Tapered Bore  
Tolerance Class SP**

**Inner Ring**

**Table 14**

d over	to	$\Delta_{dmp}$ max	min	$\Delta_{d1mp}$ max	$-\Delta_{dmp}$ min	$V_{dp}$ max	$K_{ra}$ max	$S_d$ max	$\Delta_{Bs}$ max	min	$V_{Bs}$ max
mm		$\mu\text{m}$									
18	30	+10	0	+4	0	3	3	8	0	-100	5
30	50	+12	0	+4	0	4	4	8	0	-120	5
50	80	+15	0	+5	0	5	4	8	0	-150	6
80	120	+20	0	+6	0	5	5	9	0	-200	7
120	180	+25	0	+8	0	7	6	10	0	-250	8
180	250	+30	0	+10	0	8	8	11	0	-300	10
250	315	+35	0	+12	0	9	10	13	0	-350	13
315	400	+40	0	+13	0	12	12	15	0	-400	15
400	500	+45	0	+15	0	14	12	18	0	-450	25

**Outer Ring**

D over	to	$\Delta_{Dmp}$ max	min	$V_{Dp}$ max	$K_{ra}$ max	$S_D$ max	$\Delta_{Ca}, V_{Ca}$	
mm		$\mu\text{m}$						
50	80	0	-9	5	5	8	Corresponds to $\Delta_{Bs}$ a $V_{Bs}$ of the same bearing inner ring	
80	120	0	-10	5	6	9		
120	150	0	-11	6	7	10		
150	180	0	-13	7	8	10		
180	250	0	-15	8	10	11		
250	315	0	-18	9	11	13		
315	400	0	-20	10	13	13		
400	500	0	-23	12	15	15		
500	630	0	-28	14	17	18		
630	800	0	-35	18	20	20		

**Dimension and Running Accuracy of Cylindrical Roller Bearings with Tapered Bore  
Tolerance Class UP  
Inner Ring**

**Table 15**

d over	to	$\Delta_{dmp}$ max	min	$\Delta_{d1mp}$ max	$-\Delta_{dmp}$ min	$V_{dp}$ max	$K_{ia}$ max	$S_d$ max	$\Delta_{Bs}$ max	min	$V_{Bs}$ max
mm		$\mu\text{m}$									
18	30	+6	0	+2	0	3	1,5	3	0	-25	1,5
30	50	+7	0	+3	0	3	2,0	3	0	-30	2,0
50	80	+8	0	+3	0	4	2,0	4	0	-40	3,0
80	120	+10	0	+4	0	4	3,0	4	0	-50	3,0
120	180	+12	0	+5	0	5	3,0	5	0	-60	4,0
180	250	+14	0	+6	0	6	4,0	6	0	-75	5,0
250	315	+17	0	+8	0	8	5,0	6	0	-90	6,0

**Outer Ring**

D over	to	$\Delta_{Dmp}$ max	min	$V_{Dp}$ max	$K_{ra}$ max	$S_D$ max	$\Delta_{Cs}, V_{Cs}$	
mm		$\mu\text{m}$						Corresponds to $\Delta_{Bs}$ a $V_{Bs}$ of the same bearing cone
50	80	0	-6	3	3	2		
80	120	0	-7	4	3	3		
120	150	0	-8	4	4	3		
150	180	0	-9	5	4	3		
180	250	0	-10	5	5	4		
250	315	0	-12	6	6	4		
315	400	0	-14	7	7	5		

**Dimension and Running Accuracy of Tapered Roller Bearings  
Tolerance Class P0  
Cone and Overall Bearing Width**

**Table 16**

d over	to	$\Delta_{dmp}$ max	min	$V_{dp}$ max	$V_{dmp}$ max	$K_{ia}$ max	$\Delta_{Bs}$ max	min	$\Delta_{T1s}$ max	min	$\Delta_{T1s}$ max	min	$\Delta_{T2s}$ max	min
mm		$\mu\text{m}$												
10	18	0	-12	12	9	15	0	-120	+200	0	+100	0	+100	0
18	30	0	-12	12	9	18	0	-120	+200	0	+100	0	+100	0
30	50	0	-12	12	9	20	0	-120	+200	0	+100	0	+100	0
50	80	0	-15	15	11	25	0	-150	+200	0	+100	0	+100	0
80	120	0	-20	20	15	30	0	-200	+200	-200	+100	-100	+100	-100
120	180	0	-25	25	19	35	0	-250	+350	-250	+150	-150	+200	-100
180	250	0	-30	30	23	50	0	-300	+350	-250	+150	-150	+200	-100

**Cup**

D over	to	$\Delta_{Dmp}$ max	min	$V_{Dp}$ max	$V_{Dmp}$ max	$K_{ra}$ max	$\Delta_{Cs}$ max	min
mm		$\mu\text{m}$						
18	30	0	-12	12	9	18	0	-120
30	50	0	-14	14	11	20	0	-120
50	80	0	-16	16	12	25	0	-150
80	120	0	-18	18	14	35	0	-200
120	150	0	-20	20	15	40	0	-250
150	180	0	-25	25	19	45	0	-250
180	250	0	-30	30	23	50	0	-300
250	315	0	-35	35	26	60	0	-350
315	400	0	-40	40	30	70	0	-400



**Dimension and Running Accuracy of Tapered Roller Bearings  
Tolerance Class P6X  
Cone and Overall Bearing Width**

**Table 17**

d over	to	$\Delta_{dmp}$ max	min	$V_{dp}$ max	$V_{dmp}$ max	$K_{ia}$ max	$\Delta_{Bs}$ max	min	$\Delta_{Ts}$ max	min	$\Delta_{T1s}$ max	min	$\Delta_{T2s}$ max	min	
mm		$\mu\text{m}$													
10	18	0	-12	12	9	15	0	-50	+100	0	+50	0	+50	0	
18	30	0	-12	12	9	18	0	-50	+100	0	+50	0	+50	0	
30	50	0	-12	12	9	20	0	-50	+100	0	+50	0	+50	0	
50	80	0	-15	15	11	25	0	-50	+100	0	+50	0	+50	0	
80	120	0	-20	20	15	30	0	-50	+100	0	+50	0	+50	0	
120	180	0	-25	25	19	35	0	-50	+150	0	+50	0	+100	0	

**Cup**

D over	to	$\Delta_{Dmp}$ max	min	$V_{Dp}$ max	$V_{Dmp}$ max	$K_{ea}$ max	$\Delta_{Cs}$ max	min	
mm		$\mu\text{m}$							
18	30	0	-12	12	9	18	0	-100	
30	50	0	-14	14	11	20	0	-100	
50	80	0	-16	16	12	25	0	-100	
80	120	0	-18	18	14	35	0	-100	
120	150	0	-20	20	15	40	0	-100	
150	180	0	-25	25	19	45	0	-100	
180	250	0	-30	30	23	50	0	-100	
250	315	0	-35	35	26	60	0	-100	

**Dimension and Running Accuracy of Tapered Roller Bearings  
Tolerance Class P6  
Cone and Overall Bearing Width**

**Table 18**

d over	to	$\Delta_{dmp}$ max	min	$K_{ia}$ max	$\Delta_{Bs}$ max	min	$\Delta_{Ts}$ max	min	
mm		$\mu\text{m}$							
10	18	0	-7	7	0	-200	+200	0	
18	30	0	-8	8	0	-200	+200	0	
30	50	0	-10	10	0	-240	+200	0	
50	80	0	-12	10	0	-300	+200	0	
80	120	0	-15	13	0	-400	+200	-200	
120	180	0	-18	18	0	-500	+350	-250	

**Cup**

D over	to	$\Delta_{Dmp}$ max	min	$K_{ea}$ max	$\Delta_{Cs}$	
mm		$\mu\text{m}$				
18	30	0	-8	9	Corresponds to $\Delta_{Bs}$ of the same bearing cone	
30	50	0	-9	10		
50	80	0	-11	13		
80	120	0	-13	18		
120	150	0	-15	20		
150	180	0	-18	23		
180	250	0	-20	25		
250	315	0	-25	30		

**Dimension and Running Accuracy of Tapered Roller Bearings  
Tolerance Class P5  
Cone and Overall Bearing Width**

**Table 19**

d over	to	$\Delta_{dmp}$ max	min	$V_{dp}$ max	$V_{dmp}$ max	$K_{sa}$ max	$S_d$ max	$\Delta_{Bs}$ max	min	$\Delta_{Ts}$ max	min
mm		$\mu\text{m}$									
10	18	0	-7	5	5	5	7	0	-200	+200	-200
18	30	0	-8	6	5	5	8	0	-200	+200	-200
30	50	0	-10	8	5	5	8	0	-240	+200	-200
50	80	0	-12	9	6	7	8	0	-300	+200	-200
80	120	0	-15	11	8	8	9	0	-400	+200	-200
120	180	0	-18	14	9	11	10	0	-500	+350	-250

**Cup**

D over	to	$\Delta_{Dmp}$ max	min	$V_{Dp}$ max	$V_{D}$ max	$K_{sa}$ max	$S_D$ max	$\Delta_{Cs}$	
mm		$\mu\text{m}$							
18	30	0	-8	6	5	6	8	Corresponds to $\Delta_{Bs}$ of the same bearing cone	
30	50	0	-9	7	5	7	8		
50	80	0	-11	8	6	8	8		
80	120	0	-13	10	7	10	9		
120	150	0	-15	11	8	11	10		
150	180	0	-18	14	9	13	10		
180	250	0	-20	15	10	15	11		
250	315	0	-25	19	13	18	13		

**Dimension and Running Accuracy of Thrust Bearings  
Tolerance Class P0, P6 and P5  
Shaft Washer**

**Table 20**

d <sub>2</sub> over	to	$\Delta_{dmp}$ $\Delta_{d2mp}$ max	min	$V_{dp}$ $V_{d2p}$ max	S <sub>1</sub> P0 max	P6 max	1) P5 max
mm		μm					
-	18	0	-8	6	10	5	3
18	30	0	-10	8	10	5	3
30	50	0	-12	9	10	6	3
50	80	0	-15	11	10	7	4
80	120	0	-20	15	15	8	4
120	180	0	-25	19	15	9	5
180	250	0	-30	23	20	10	5
250	315	0	-35	26	25	13	7
315	400	0	-40	30	30	15	7
400	500	0	-45	34	30	18	9
500	630	0	-50	38	35	21	11
630	800	0	-75	-	40	25	13

**Housing Washer**

D over	to	$\Delta_{Dmp}$ max	min	$V_{Dp}$ max	S <sub>e</sub>	1)
mm		μm				
18	30	0	-13	10	Corresponds to S <sub>1</sub> of shaft washer of the same bearing	
30	50	0	-16	12		
50	80	0	-19	14		
80	120	0	-22	17		
120	180	0	-25	19		
180	250	0	-30	23		
250	315	0	-35	26		
315	400	0	-40	30		
630	800	0	-75	55		
1250	1600	0	-160	-		

1) Not valid for thrust spherical roller bearings

## 2.4 Internal Clearance

Bearing clearance is the value of one bearing displacement length of assembled bearing with respect to the other ring from one end position to the other one. The displacement can be in radial direction (radial clearance) or axial (axial clearance).

In a mounted bearing smaller radial clearance can be found than the same bearing had before mounting. Radial clearance reduction is caused by interference of the bearing rings on the shaft and in housing bore and thus it is dependent on selected tolerance of bearing seating surface diameters.

Another change of radial clearance, mainly its reduction, arises during operation from temperatures evoked by its own operation and surrounding sources, but also by elastic deformations caused by load.

Clearance for standard designed bearings is determined so that one of the bearing rings can be fixed, what is sufficient for most operation conditions in the arrangement. For special arrangements with different requirement on the radial clearance bearings with various radial clearance designated C1 up to C5 are produced.

Values for various internal clearances according to the standard ISO 5753 are shown for individual bearing types in tables 21 up to 27 and these values are valid for non-mounted bearings by zero measuring load.

For double row angular contact ball bearings instead of radial clearance the axial clearance measured at axial load 100 N is introduced.

Single row angular contact ball bearings and single row tapered roller bearings are usually mounted in pairs and the radial or axial clearance is adjusted during mounting.

Bore Diameter		Radial Clearance										Single Row Separable Ball Bearings Type E and BO		Radial Clearance		
d over	to	C2		normal		C3		C4		C5		min	max	min	max	
mm	mm	min	max	min	max	min	max	min	max	min	max	μm	μm	μm	μm	
2,5	10	0	7	2	13	8	23	14	29	20	37	E10, E12	15	30		
10	18	0	9	3	18	11	25	18	33	25	45	E15	15	30		
18	24	0	10	5	20	13	28	20	36	28	48	BO17, E17	25	45		
24	30	1	11	5	20	13	28	23	41	30	53	E20	20	40		
30	40	1	11	6	20	15	33	28	46	40	64					
40	50	1	11	6	23	18	36	30	51	45	73					
50	65	1	15	8	28	23	43	38	61	55	90					
65	80	1	15	10	30	25	51	46	71	65	105					
80	100	1	18	12	36	30	58	53	84	75	120					
100	120	2	20	15	41	36	66	61	97	90	140					
120	140	2	23	18	48	41	81	71	114	105	160					
140	160	2	23	18	53	46	91	81	130	120	180					
160	180	2	25	20	61	53	102	91	147	135	200					
180	200	2	30	25	71	63	117	107	163	150	215					

Bore Diameter		Axial Clearance							
d over	to	C2		normal		C3		C4	
mm	mm	min	max	min	max	min	max	min	max
6	10	1	11	5	21	12	28	25	45
10	18	1	12	6	23	13	31	27	47
18	24	2	14	7	25	16	34	28	48
24	30	2	15	8	27	18	37	30	50
30	40	2	16	9	29	21	40	33	54
40	50	2	19	11	33	23	44	36	58
50	65	3	22	13	36	26	48	40	63
65	80	3	24	15	40	30	54	46	71

**Radial Clearance of Double Row Self-Aligning Ball Bearing** **Table 23**

Bore Diameter		Cylindrical Bore Radial Clearance										Tapered Bore Radial Clearance									
d over	to	C2		normal		C3		C4		C5		C2		normal		C3		C4		C5	
		min	max	min	max	min	max	min	max	min	max	min	max	min	max	min	max	min	max	min	max
mm		µm																			
2,5	6	1	8	5	15	10	20	15	25	21	33	-	-	-	-	-	-	-	-	-	-
6	10	2	9	6	17	12	25	19	33	27	42	-	-	-	-	-	-	-	-	-	-
10	14	2	10	6	19	13	26	21	35	30	48	-	-	-	-	-	-	-	-	-	-
14	18	3	12	8	21	15	28	23	37	32	50	-	-	-	-	-	-	-	-	-	-
18	24	4	14	10	23	18	30	25	39	34	52	7	17	13	26	20	33	28	42	37	55
24	30	5	16	11	24	19	35	29	46	40	58	9	20	15	28	23	39	33	50	44	62
30	40	6	18	13	29	23	40	34	53	46	66	12	24	19	35	29	46	40	59	52	72
40	50	6	19	14	31	25	44	37	57	50	71	14	27	22	39	33	52	45	65	58	79
50	65	7	21	16	36	30	50	45	69	62	88	18	32	27	47	41	61	56	80	73	99
65	80	8	24	18	40	35	60	54	83	76	108	23	39	35	57	50	75	69	98	91	123
80	100	9	27	22	48	42	70	64	96	89	124	29	47	42	68	62	90	84	116	109	144
100	120	10	31	25	56	50	83	75	114	105	145	35	56	50	81	75	108	100	139	130	170
120	140	10	38	30	68	60	100	90	135	125	175	-	-	-	-	-	-	-	-	-	-
140	160	15	44	35	80	70	120	110	161	150	210	-	-	-	-	-	-	-	-	-	-

**Radial Clearance of Single Row Cylindrical Roller Bearings** **Table 24**

Bore Diameter		Radial Clearance									
d over	to	C2		normal		C3		C4		C5	
		min	max	min	max	min	max	min	max	min	max
mm		µm									
10	24	0	25	20	45	35	60	50	75	65	90
24	30	0	25	20	45	35	60	50	75	70	95
30	40	5	30	25	50	45	70	60	85	80	105
40	50	5	35	30	60	50	80	70	100	95	125
50	65	10	40	40	70	60	90	80	110	110	140
65	80	10	45	40	75	65	100	90	125	130	165
80	100	15	50	50	85	75	110	105	140	155	190
100	120	15	55	50	90	85	125	125	165	180	220
120	140	15	60	60	105	100	145	145	190	200	245
140	160	20	70	70	120	115	165	165	215	225	275
160	180	25	75	75	125	120	170	170	220	250	300
180	200	35	90	90	145	140	195	195	250	275	330
200	225	45	105	105	165	160	220	220	280	305	365
225	250	45	110	110	175	170	235	235	300	330	395
250	280	55	125	125	195	190	260	260	330	370	440
280	315	55	130	130	205	200	275	275	350	410	485
315	355	65	145	145	225	225	305	305	385	455	535
355	400	100	190	190	280	280	370	370	460	510	600
400	450	110	210	210	310	310	410	410	510	565	665
450	500	110	220	220	330	330	440	440	550	625	735
500	560	120	240	240	360	360	480	480	600	695	815
560	630	140	260	260	380	380	500	500	620	780	900
630	710	145	285	285	425	425	565	565	705	870	1010
710	800	150	310	310	470	470	630	630	790	980	1140
800	900	180	350	350	520	520	690	690	860	1100	1270
900	1000	200	390	390	580	580	770	770	960	1220	1410
1000	1120	220	430	430	640	640	850	850	1060	1360	1570
1120	1250	230	470	470	710	710	950	950	1190	1520	1760

**Radial Clearance of Double Row Cylindrical Roller Bearings with Tapered Bore Bearing with Non-Interchangeable Rings Determined for Machine Tool Spindles**

**Table 25**

Bore Diameter d over to		Radial Clearance C1NA min max C2NA min max				Bore Diameter d over to		Radial Clearance C1NA min max C2NA min max			
mm		µm				mm		µm			
24	30	15	25	25	35	160	180	55	85	75	110
30	40	15	25	25	40	180	200	60	90	80	120
40	50	17	30	30	45	200	225	60	95	90	135
50	65	20	35	35	50	225	250	65	100	100	150
65	80	25	40	40	60	250	280	75	110	110	165
80	100	35	55	45	70	280	315	80	120	120	180
100	120	40	60	50	80	315	355	90	135	135	200
120	140	45	70	60	90	355	400	100	150	150	225
140	160	50	75	65	100	400	450	110	170	170	255

**Radial Clearance of Single Row Needle Roller Bearings with Interchangeable Rings**

**Table 26**

Bore Diameter d over to		Radial Clearance normal min max		C3 min max	
mm		µm			
10	14	10	50	25	70
14	18	15	55	35	75
18	24	25	65	40	80
24	30	30	65	50	80
30	40	40	75	60	95
40	50	40	85	65	100
50	65	45	90	70	120
65	80	50	110	75	135
80	100	60	115	95	150
100	120	70	125	115	70
120	140	80	155	130	205
140	160	80	160	140	210

Radial Clearance of Double Row Spherical Roller Bearings

Table 27

Bore Diameter		Cylindrical Bore Radial Clearance									
d over	to	C2		normal		C3		C4		C5	
		min	max	min	max	min	max	min	max	min	max
mm		µm									
30	40	15	30	30	45	45	60	60	80	80	100
40	50	20	35	35	55	55	75	75	100	100	125
50	65	20	40	40	65	65	90	90	120	120	150
65	80	30	50	50	80	80	110	110	145	145	180
80	100	35	60	60	100	100	135	135	180	180	225
100	120	40	75	75	120	120	160	160	210	210	260
120	140	50	95	95	145	145	190	190	240	240	300
140	160	60	110	110	170	170	220	220	280	280	350
160	180	65	120	120	180	180	240	240	310	310	390
180	200	70	130	130	200	200	260	260	340	340	430
200	225	80	140	140	220	220	290	290	380	380	470
225	250	90	150	150	240	240	320	320	420	420	520
250	280	100	170	170	260	260	350	350	460	460	570
280	315	110	190	190	280	280	370	370	500	500	630
315	355	120	200	200	310	310	410	410	550	550	690
355	400	130	220	220	340	340	450	450	600	600	750
400	450	140	240	240	370	370	500	500	660	660	820
450	500	140	260	260	410	410	550	550	720	720	900
500	560	150	280	280	440	440	600	600	780	780	1000
560	630	170	310	310	480	480	650	650	850	850	1100
630	710	190	350	350	530	530	700	700	920	920	1190
710	800	210	390	390	580	580	770	770	1010	1010	1300
800	900	230	430	430	650	650	860	860	1120	1120	1440

Bore Diameter		Tapered Bore Radial Clearance									
d over	to	C2		normal		C3		C4		C5	
		min	max	min	max	min	max	min	max	min	max
mm		µm									
30	40	25	35	35	50	50	65	65	85	85	105
40	50	30	45	45	60	60	80	80	100	100	130
50	65	40	55	55	75	75	95	95	120	120	160
65	80	50	70	70	95	95	120	120	150	150	200
80	100	55	80	80	110	110	140	140	180	180	230
100	120	65	100	100	135	135	170	170	220	220	280
120	140	80	120	120	160	160	200	200	260	260	330
140	160	90	130	130	180	180	230	230	300	300	380
160	180	100	140	140	200	200	260	260	340	340	430
180	200	110	160	160	220	220	290	290	370	370	470
200	225	120	180	180	250	250	320	320	410	410	520
225	250	140	200	200	270	270	350	350	450	450	570
250	280	150	220	220	300	300	390	390	490	490	620
280	315	170	240	240	330	330	430	430	540	540	680
315	355	190	270	270	360	360	470	470	590	590	740
355	400	210	300	300	400	400	520	520	650	650	820
400	450	230	330	330	440	440	570	570	720	720	910
450	500	260	370	370	490	490	630	630	790	790	1000
500	560	290	410	410	540	540	680	680	870	870	1100
560	630	320	460	460	600	600	760	760	980	980	1230
630	710	350	510	510	670	670	850	850	1090	1090	1360
710	800	390	570	570	750	750	960	960	1220	1220	1500
800	900	440	640	640	840	840	1070	1070	1370	1370	1690

## 2.5 Cages

Cage in the rolling bearing fulfills the following roles:

- separates rolling elements evenly around the periphery
- prevents contact of rolling elements and their sliding
- prevents falling out of the rolling elements from separable or self-aligning bearings when mounting.

From the point of view of design and material the cages are divided into pressed and machined.

Pressed cages are made of steel or brass sheet and are mostly used in dimensionally smaller and medium bearings. Their advantage in comparison with the solid cages is the smaller weight. Machined cages are made of steel, brass, bronze, light metals or plastic in various designs. Cages made of metals are used when there are higher demands on the cage rigidity and the bearing is determined for higher operational temperatures. Cages are radially centered on the rolling elements in bearings, this is the most usual way, or they are centered on the rib of either of the bearing rings.

Bearings without cages, i.e. with full complement of rolling elements, are only rarely used, namely only for some bearing types, e.g. single row needle roller bearings.

In the texts about individual bearing types the survey of cages in standard design and delivery possibilities of bearings with cages of non-standard design are given in the section Cages.

## 2.6 Shields and Seals

Bearings with sealing on one or both sides are manufactured with shields (Z, ZZ, ZR, ZZR) or seals (RS, ZRS, RSR, ZRSR).

Shields form a non-contact sealing. In design Z and ZZ the fitting for the shield is in the inner ring, in design ZR and ZZR the shield adheres on the smooth rib of the bearing inner ring.

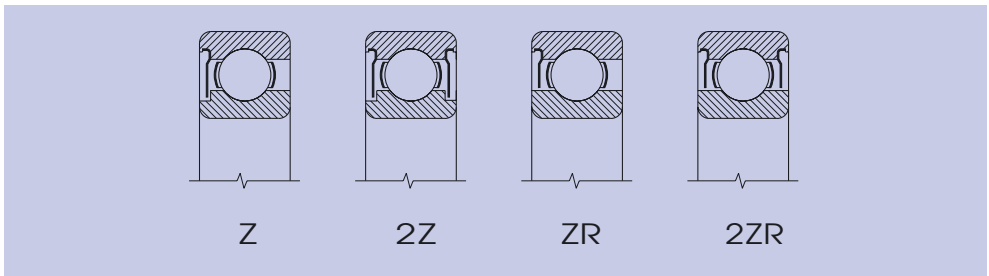

Sealing is created by sealing rings made of rubber vulcanized on sheet steel reinforcement, which create an effective contact sealing with a chamfered fitting on the inner ring (RS, ZRS) as well as in design with contact on the smooth rib of the inner ring (RSR, ZRSR).

Seals and sealing rings are fastened in the grooves of the outer ring and are unseparable.

Sealing RS, ZRS, RSR, ZRSR can be used for temperature range -30 °C to +110 °C, sealing RS1, -ZRS1, RSR1 and -ZRSR1 for temperature range -45 °C to +120 °C, sealing RS2, -ZRS2, RSR2, -ZRSR2 for temperature range -60 °C to +150 °C.

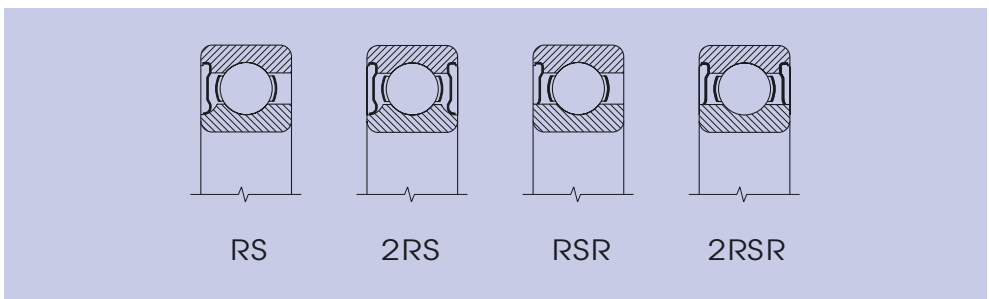



Bearings with sealings on both sides in standard design are filled with grease of a temperature range from  $-30^{\circ}\text{C}$  to  $110^{\circ}\text{C}$ , whose qualities secure lubrication usually during the whole bearing life at normal operational conditions. Bearings in this design cannot be relubricated.

## 3 Bearing Arrangement Design

### 3.1 General Principles of Rolling Bearing Arrangement Design

Rotating shaft or another component arranged in rolling bearings is guided by them in radial as well as in axial direction so that the basic condition, the movement uniqueness, can be fulfilled. The component should be, as far as possible, statically determined, i.e. supported in two points radially and in one point axially.

A typical example of such an arrangement is in Pict. 9, where the shaft is radially guided in two bearings, one of which secures it in axial direction. The locating bearing carries the radial load and simultaneously also the axial load in both directions. Radial bearings that can accommodate combined load are mostly used as locating bearings, which carry, e.g. single row ball bearings, double row angular contact ball bearings, double row self-aligning ball bearings, double row spherical roller bearings or single row angular contact ball bearings and tapered roller bearings. The two last mentioned bearing types must be mounted in pairs. The non-locating bearing carries only radial load and must permit certain displacement of the shaft in axial direction so that arising of non-desired axial preload caused by environment (temperature dilatations, production inaccuracies of connecting arrangement components, etc.) can be hindered.

Axial displacement can be secured by displacement between one bearing ring and a machine part, which is directly connected with the bearing, e.g. between outer bearing ring and housing bore (Pict. 9a) or directly in the bearing (Pict. 9b).

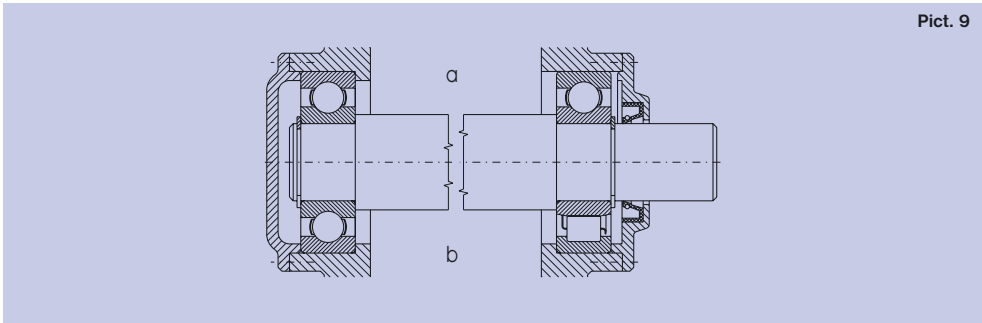

Arrangements, in which greater radial and axial loads act by higher rotational speed, should be set up so that the bearing can accommodate only radial or axial forces, see Pict. 10. In these cases it is possible to use for radial guidance some of the radial bearings and for axial guidance those radial bearings which are also able to carry axial load or a pair of these bearings, or double direction thrust bearing, or a pair of single direction thrust bearings. There is a condition where the axially locating thrust bearing should be arranged with radial clearance.

Another, often used solution is the arrangement of two bearings, whose design enables the accommodation both radial and axial loads. Both bearings accommodate alternately the axial load, always according to direction of force acting, and simultaneously they carry also the radial load. An example of this arrangement is shown in Pict. 11.

As a verified design the pair of single row tapered roller bearings or single row angular contact ball bearings are used. There can be used other bearing types which are able to carry the load both in radial and axial direction simultaneously, e.g. separable single row ball bearings or single row cylindrical roller bearings in NJ design, etc.

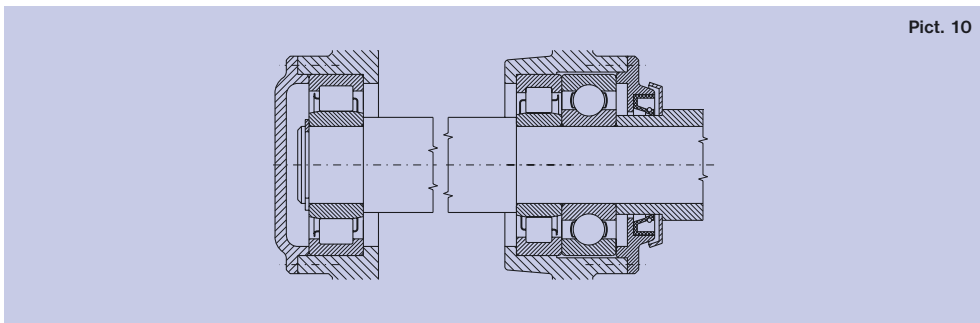

## 3.2 Bearing Location

Radial and axial bearing location on the shaft and in the housing bore or another part has a direct connection with the whole arrangement design. When selecting the way of location, the character and acting forces magnitude, the operating temperature in the arrangement and material of mating parts must be taken into account.

Mounting, dismounting and maintenance methods must be taken into consideration when designing mating parts dimensions.

### 3.2.1 Radial Location of Bearing

The bearing is located in radial direction on the mating cylindrical shaft and housing bore surface. In some cases, adapter or withdrawal sleeves are used by mounting on the shaft, or the bearing can be mounted directly on the tapered shaft.

The correct radial location of the bearing on the shaft significantly influences utilization of its load rating and correct function in arrangement. The following viewpoints are important:

- a) safe location and uniform supporting of bearings
- b) simple mounting and dismounting
- c) displacement of non-locating bearing in axial direction

Basically, both bearing rings should be mounted in tight fits, because only in this way their reliable supporting around the whole periphery and radial fixing against turning can be achieved. To make mounting and dismounting easier or for moving the non-locating ring, a loose fit of one of the rings is permissible.

When selecting correct radial bearing location, following influences must be taken into account.

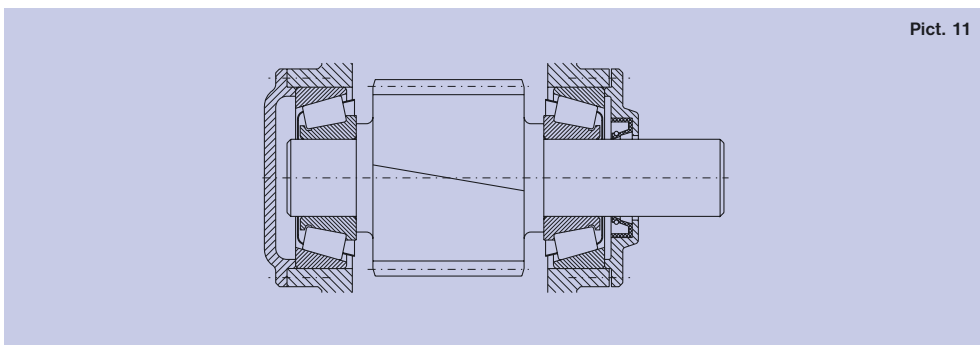

**Circumferential Load** - occurs if the respective bearing ring rotates and the load direction is not changed or if the ring rotates and the load does not rotate. The bearing ring periphery is gradually loaded during one revolution. In this case the loaded bearing ring must be always fitted with necessary interference fit.

**Point Load** - occurs when the bearing ring does not rotate and the external force is constantly directed into the same ring raceway point or if the ring and load rotate at the same rotating speed. The ring subjected to point load can be mounted with loose fit, if the conditions require it.

**Indeterminate Load** - occurs if the ring is subjected to varying external forces at which directions and load changes cannot be determined (e.g. unbalanced mass, shocks, etc.). Under these conditions in most applications bearings with greater radial clearance should be used.

**Load Magnitude** - directly influences selection of the interference fit (higher load - larger interference), especially in cases of impact loads. A firm fitting on the shaft or in the housing causes ring deformation, and as a result reduction of radial clearance arises. To secure the necessary radial clearance in the firm arrangement, it is necessary to use bearings with greater radial clearance. Resulting clearance after mounting depends on the bearing type and its dimension.

**Bearing Size and Type** - determines the size of necessary interference fit of the fitted ring. For smaller sized bearings smaller interference fits are selected, and vice versa. Relatively smaller interferences are used, e.g. for the same sizes of ball bearings in comparison with the cylindrical roller, tapered roller or spherical roller bearings.

**Material and Design of Mating Components** must be taken into account when determining their production tolerance. Results of practical experience are shown in the following tables. In cases where bearings are mounted into housings made of light metal alloys or on journals of hollow shafts, arrangements with higher interference are selected.

Split housings are not suitable for arrangements with higher interferences, because there is danger of the bearing pinching in the dividing plane.

**Heating generating** in the bearing can cause loosening of the interference on the journal and turning of the ring. In the housing a converse case can come into being. The heating causes clearance decreasing and subsequently limiting and even stopping of the axial displacement of the non-locating bearing ring. That is why we pay a great deal of attention to this fact when designing an arrangement.

**Fitting Accuracy** from the point of view of its tolerances and geometric shapes is important because it can be transmitted towards the bearing ring raceways and defines the arrangement accuracy.

When using bearings with normal tolerance class, the tolerance of journal seating surface IT6 is selected, and for housing seating surface tolerance IT7.

For smaller dimensioned ball and cylindrical roller bearings it is possible to use for the journal tolerance IT5 and housing bore IT6.

For bearings in higher tolerance classes, for arrangements with high requirements on accuracy, e.g. spindles of machine tools, the least tolerance class IT5 is recommended for the shaft and for housing IT6.

Permissible ovality and conicity deviation and permissible lateral bearing runout of supporting surfaces must be in reference to axis smaller than the diameter tolerance of the journal and bore.

With higher bearing tolerance class also requirements on the seating surface accuracy increase. Recommended values are shown in tables 28 and 29.

**Mounting and Dismounting of bearings**, if one of the rings is arranged with a loose fit it is simple. If, because of operational reasons, it is necessary to arrange both of the rings with an interference, a suitable bearing type should be selected, e.g. a separable bearing (tapered roller, cylindrical roller, needle roller bearing) or a bearing with tapered bore. Journals for sleeve arrangements of bearings with tapered bore can be in tolerance class h9 or h10, geometric shape should be in tolerance class IT5 or IT7 according to arrangement requirements.

**Axial Displacement** of Non-Locating Bearing Rings must be secured by all operation conditions. When using a non-separable bearing, displacement of the stationary loaded ring is reached by its fitting with clearance (moveable).

In light metal alloy housings it is necessary, if the outer ring is fitted with clearance, to put a steel bush in the bore.

A reliable displacibility in axial direction is reached by using cylindrical roller bearing type N and NU or radial needle bearing.

Recommended journal and bore diameter tolerances of the mating components for radial and thrust bearings are shown in tables 30 to 35.

### 3.2.2 Axial Securing of Bearing

Inner bearing ring with cylindrical bore arranged on the journal with interference fit (fixed) is usually secured in the axial direction by means of a locknut, end-plate or snap ring, when the other face is usually supported by the shaft shoulder. Surrounding parts are used as abutment faces for inner rings, and if necessary, spacing rings are inserted between this component and bearing inner ring. Examples of axial bearing securing are shown in Pict. 12.

Recommended Shape Accuracies of Bearing Seating Fits			Table 28
Bearing Tolerance Class	Fitting Location	Permissible Ovality Deviation	Permissible Lateral Runout of Carrying Surfaces in Reference to Axis
P0, P6	shaft	$\frac{IT5}{2}$	IT3
	housing	$\frac{IT6}{2}$	IT4
P5, P4	shaft	$\frac{IT3}{2}$	IT2
	housing	$\frac{IT4}{2}$	IT3

Standard Tolerances IT2 to IT6				Table 29		
Nominal Diameter		IT2	IT3	Tolerance Class		IT6
over	to			IT4	IT5	
mm		µm				
6	10	1,5	2,5	4	6	9
10	18	2,0	3,0	5	8	11
18	30	2,5	4,0	6	9	13
30	50	2,5	4,0	7	11	16
50	80	3,0	5,0	8	13	19
80	120	4,0	6,0	10	15	22
120	180	5,0	8,0	12	18	25
180	250	7,0	10,0	14	20	29
250	315	8,0	12,0	16	23	32
315	400	9,0	13,0	18	25	36
400	500	10,0	15,0	20	27	40

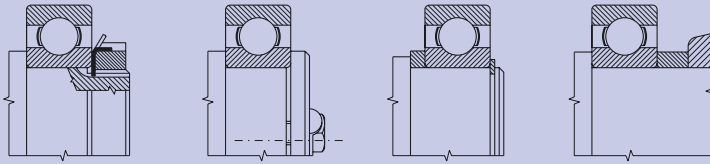

Radial Bearing Shaft Diameter Tolerances (Valid for Solid Steel Shafts)

Table 30

Operating Conditions	Arrangement Examples	Journal Diameter [mm]			Tolerance
		Ball Bearings	Cylindrical, Needle 1) Tapered Roller Bearings	Spherical Roller Bearings	
<b>Inner Ring Point Load</b>					
Light and Normal Load $P_r \leq 0,15 C_r$	Free wheels, sheaves, belt pulleys	All Diameters			$g6^{2)}$
Heavy Impact Load $P_r > 0,15 C_r$	Industrial truck wheels, tension pulleys	All Diameters			$h6$
<b>Inner Ring Circumferential Load or Indeterminate Load</b>					
Light and Variable Load $P_r \leq 0,07 C_r$	transport equipments, ventilators	(18) to 100	$\leq 40$	-	$j6$ $k6$
Normal and Heavy Load $P_r > 0,07 C_r$ pumps, combustion motors, gear boxes, woodworking machines	General engineering, electric motors, turbines, (100) to 140 (140) to 200	$\leq 18$	-	-	$j5$
		(18) to 100	$\leq 40$	-	$k5 (k6)^{3)}$ $m5 (m6)^{3)}$
		(40) to 100	(40) to 100	(40) to 65	$m6$
		(100) to 140	(140) to 200	(65) to 100	$n6$ $p6$
Extremely Heavy Load, Impacts, Complicated Operating Conditions: $P_r > 0,15 C_r$	Axle bearings for railway vehicles, traction motors, rolling mills	-	(50) to 140	(50) to 100	$n6^{4)}$ $p6^{4)}$
		-	$> 500$	(140) to 500 (100) to 500	$r6 (p6)^{4)}$
		-	$> 500$	$> 500$	
High Arrangement Accuracy under Light Load $P_r \leq 0,07 C_r$	Machine tools	(18) to 100	$\leq 40$	(40) to 140	$h5^{5)}$ $k5^{5)}$ $m5$
<b>Exclusively Axial Load</b>		All Diameters			$j6$
<b>Bearings with Tapered Bore and Adapter or Withdrawal Sleeve</b>					
All Kinds of Load	General arrangements, axle bearings for railway vehicles.	All Diameters			$h9/IT5$
	Not complicated arrangements	All Diameters			$h10/IT7$

1) Tolerances for needle roller bearings without rings, see page 133

2) Tolerance  $f6$  can be selected for securing axial displacibility

3) Tolerances in brackets are selected usually for single row tapered roller bearings or at low rotational speeds where tolerance dispersion is not significant

4) It is necessary to use bearings with higher radial clearance than normal

5) Tolerances for single row ball bearings in tolerance classes P5 and P4 are shown on page 89

Housing Bore Diameter Tolerances for Radial Bearings (Valid for Steel, Cast and Cast Steel Housings)				Table 31
Operating Conditions	Displacibility of Outer Ring	Housing	Arrangement Examples	Tolerance
Outer Ring Circumferential Load				
Heavy Impact Load $P_r > 0.15 C_r$ Thin Walled Housings	not displaceable	one-part	Wheel hubs with cylindrical roller bearings, big end bearings	P7
Normal and Heavy Load $P_r > 0.07 C_r$	not displaceable		Wheel hubs with ball bearings, crane travel wheels, crankshaft bearings	N7
Light and Variable Load $P_r \leq 0.07 C_r$	not displaceable		Conveyor rollers, tension pulleys	M7
Indeterminate Load				
Heavy Impact Load $P_r > 0.15 C_r$	not displaceable		Traction motors	M7
Heavy and Normal Load $P_r > 0.07 C_r$	As a rule, not displaceable	one-part	Electric motors, pumps, crankshafts	K7
Light and Varying Load $P_r \leq 0.07 C_r$	As a rule, displaceable		Electric motors, pumps, crankshafts	J7
Accurate Arrangement				
Light Load $P_r \leq 0.07 C_r$	As a rule, not displaceable	one-part	Cylindrical roller bearings for machine tools ball bearings for machine tools. Small electric motors	K6 <sup>1)</sup>
	Displaceable			J6 <sup>2)</sup>
	Easily displaceable			H6
Outer Ring Point Load				
Any Load			General engineering, axle bearings of railway vehicles	H7 <sup>3)</sup>
Light and Normal Load $P_r \leq 0.15 C_r$	Easily displaceable	One-part or two-part	General engineering, less complicated engineering Drying rollers of paperworking machines, big electric motors	H8 G7 <sup>4)</sup>

1) For heavy loads tighter tolerances are selected - M6 or N6. For cylindrical roller bearings with tapered bore tolerances K5 or M5.  
2) Tolerances for single row ball bearings in tolerances P5 and P4 - see page 89.  
3) For bearings with outer diameter  $D < 250$  mm, with temperature difference between outer ring and housing over  $10^\circ\text{C}$ , tolerance G7 is selected  
4) For bearings with outer diameter  $D > 250$  mm, with temperature difference between outer ring and housing over  $10^\circ\text{C}$ , tolerance F7 is selected

Journal Diameter Tolerance for Thrust Bearings				Table 32
Bearing Type	Load		Journal Diameter [mm]	Tolerance
Thrust Ball Bearings	Exclusively Axial Load		All Diameters	j6
Thrust Spherical Roller Bearings				j6
	Simultaneously Axial and Radial Loads	Stationary Load of Shaft Washer or Indeterminate Load	All Diameters	j6
		Rotating Load of Shaft	$\leq 200$	k6
		Washer	(200) to 400 > 400	m6 n6

Housing Bore Diameter Tolerances for Thrust Bearings				Table 33
Bearing Type	Load		Note	Tolerance
Thrust Ball Bearings	Exclusively Axial Load		In common arrangements housing washer can have clearance	H8
			Housing washer mounted with radial clearance	-
Thrust Spherical Roller Bearings	Simultaneously Axial and Radial Load	Stationary Load or Indeterminate Load of Housing Washer		H7
		Rotating Load of Housing Washer		M7

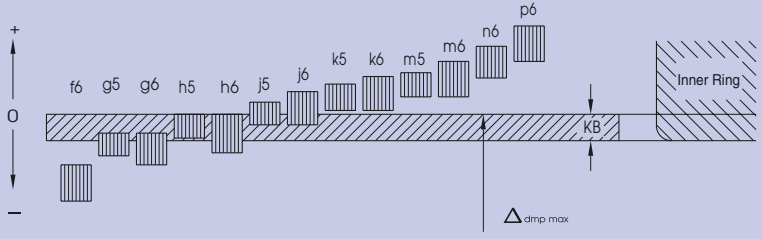

**Journal Diameter Tolerance Limiting Deviations**

**Table 34**

Journal Nominal Diameter over to	f6		g5		g6		h5		h6		j5		j6(js6)		k5	
	upper	lower	upper	lower	upper	lower	upper	lower	upper	lower	upper	lower	upper	lower	upper	lower
mm	μm															
1 3	-6	-12	-2	-6	-2	-8	0	-4	0	-6	+2	-2	+4	-2	+4	0
3 6	-10	-18	-4	-9	-4	-12	0	-5	0	-8	+3	-2	+6	-2	+6	+1
6 10	-13	-22	-5	-11	-5	-14	0	-6	0	-9	+4	-2	+7	-2	+7	+1
10 18	-16	-27	-6	-14	-6	-17	0	-8	0	-11	+5	-3	+8	-3	+9	+1
18 30	-20	-33	-7	-16	-7	-20	0	-9	0	-13	+5	-4	+9	-4	+11	+2
30 50	-25	-41	-9	-20	-9	-25	0	-11	0	-16	+6	-5	+11	-5	+13	+2
50 80	-30	-49	-10	-23	-10	-29	0	-13	0	-19	+6	-7	+12	-7	+15	+2
80 120	-36	-58	-12	-27	-12	-34	0	-15	0	-22	+6	-9	+13	-9	+18	+3
120 180	-43	-68	-14	-32	-14	-39	0	-18	0	-25	+7	-11	+14	-11	+21	+3
180 250	-50	-79	-15	-35	-15	-44	0	-20	0	-29	+7	-13	+16	-13	+24	+4
250 315	-56	-88	-17	-40	-17	-49	0	-23	0	-32	+7	-16	+16	-16	+27	+4
315 400	-62	-98	-18	-43	-18	-54	0	-25	0	-36	+7	-18	+18	-18	+29	+4
400 500	-68	-108	-20	-47	-20	-60	0	-27	0	-40	+7	-20	+20	-20	+32	+5
500 630	-76	-120	-	-	-22	-66	-	-	0	-44	-	-	+22	-22	-	-
630 800	-80	-130	-	-	-24	-74	-	-	0	-50	-	-	+25	-25	-	-
800 1000	-86	-142	-	-	-26	-82	-	-	0	-56	-	-	+28	-28	-	-
1000 1250	-98	-164	-	-	-28	-94	-	-	0	-66	-	-	+33	-33	-	-

Journal Nominal Diameter over to	k6		m5		m6		n6		p6		h9 <sup>1)</sup>		IT5		h10 <sup>1)</sup>		IT7	
	upper	lower	upper	lower	upper	lower	upper	lower	upper	lower	upper	lower	upper	lower	upper	lower	upper	lower
mm	μm																	
1 3	+6	0	+6	+2	+8	+2	+10	+4	+12	+6	0	-25	4	0	-40	10		
3 6	+9	+1	+9	+4	+12	+4	+16	+8	+20	+12	0	-30	5	0	-48	12		
6 10	+10	+1	+12	+6	+15	+6	+19	+10	+24	+15	0	-36	6	0	-58	15		
10 18	+12	+1	+15	+7	+18	+7	+23	+12	+29	+18	0	-43	8	0	-70	18		
18 30	+15	+2	+17	+8	+21	+8	+28	+15	+35	+22	0	-52	9	0	-84	21		
30 50	+18	+2	+20	+9	+25	+9	+33	+17	+42	+26	0	-62	11	0	-100	25		
50 80	+21	+2	+24	+11	+30	+11	+39	+20	+51	+32	0	-74	13	0	-120	30		
80 120	+25	+3	+28	+13	+35	+13	+45	+23	+59	+37	0	-87	15	0	-140	35		
120 180	+28	+3	+33	+15	+40	+15	+52	+27	+68	+43	0	-100	18	0	-160	40		
180 250	+33	+4	+37	+17	+46	+17	+60	+31	+79	+50	0	-115	20	0	-185	46		
250 315	+36	+4	+43	+20	+52	+20	+66	+34	+88	+56	0	-130	23	0	-210	52		
315 400	+40	+4	+46	+21	+57	+21	+73	+37	+98	+62	0	-140	25	0	-230	57		
400 500	+45	+5	+50	+23	+63	+23	+80	+40	+108	+68	0	-155	27	0	-250	63		
500 630	+44	0	-	-	+70	+26	+88	+44	+122	+78	0	-175	30	0	-280	70		
630 800	+50	0	-	-	+80	+30	+100	+50	+138	+88	0	-200	35	0	-320	80		
800 1000	+56	0	-	-	+90	+34	+112	+56	+156	+100	0	-230	40	0	-360	90		
1000 1250	+66	0	-	-	+106	+40	+132	+66	+186	+120	0	-260	46	0	-420	105		

1) For journals made in tolerance h9 and H10 for bearings with adapter or withdrawal sleeves deviations of roundness and cylindricity must not exceed basic tolerances IT5 and IT7

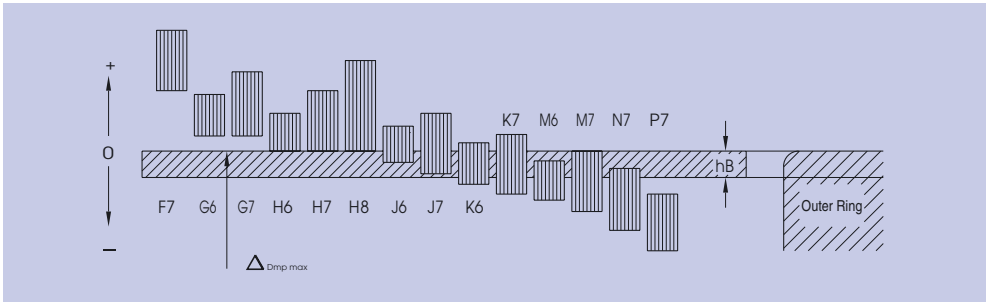

**Bore Diameter Tolerance Limiting Deviations** **Table 35**

Bore Nominal Diameter over to	F7		G6		G7		H6		H7		H8		J6(Js6)	
	upper	lower	upper	lower	upper	lower	upper	lower	upper	lower	upper	lower	upper	lower
mm	μm													
6 10	+28	+13	+14	+5	+20	+5	+9	0	+15	0	+22	0	+5	-4
10 18	+34	+16	+17	+6	+24	+6	+11	0	+18	0	+27	0	+6	-5
18 30	+41	+20	+20	+7	+28	+7	+13	0	+21	0	+33	0	+8	-5
30 50	+50	+25	+25	+9	+34	+9	+16	0	+25	0	+39	0	+10	-6
50 80	+60	+30	+29	+10	+40	+10	+19	0	+30	0	+46	0	+13	-6
80 120	+71	+36	+34	+12	+47	+12	+22	0	+35	0	+54	0	+16	-6
120 180	+83	+43	+39	+14	+54	+14	+25	0	+40	0	+63	0	+18	-7
180 250	+96	+50	+44	+15	+61	+15	+29	0	+46	0	+72	0	+22	-7
250 315	+108	+56	+49	+17	+69	+17	+32	0	+52	0	+81	0	+25	-7
315 400	+119	+62	+54	+18	+75	+18	+36	0	+57	0	+89	0	+29	-7
400 500	+131	+68	+60	+20	+83	+20	+40	0	+63	0	+97	0	+33	-7
500 630	+146	+76	+66	+22	+92	+22	+44	0	+70	0	+110	0	+22	-22
630 800	+160	+80	+74	+24	+104	+24	+50	0	+80	0	+125	0	+25	-25
800 1000	+176	+86	+82	+26	+116	+26	+56	0	+90	0	+140	0	+28	-28
1000 1250	+203	+98	+94	+28	+133	+28	+66	0	+105	0	+165	0	+33	-33
1250 1600	+235	+110	+108	+30	+155	+30	+78	0	+125	0	+195	0	+39	-39

Bore Nominal Diameter over to	J7(Js7)		K6		K7		M6		M7		N7		P7	
	upper	lower	upper	lower	upper	lower	upper	lower	upper	lower	upper	lower	upper	lower
mm	μm													
6 10	+8	-7	+2	-7	+5	-10	-3	-12	0	-15	-4	-19	-9	-24
10 18	+10	-8	+2	-9	+6	-12	-4	-15	0	-18	-5	-23	-11	-29
18 30	+12	-9	+2	-11	+6	-15	-4	-17	0	-21	-7	-28	-14	-35
30 50	+14	-11	+3	-13	+7	-18	-4	-20	0	-25	-8	-33	-17	-42
50 80	+18	-12	+4	-15	+9	-21	-5	-24	0	-30	-9	-39	-21	-51
80 120	+22	-13	+4	-18	+10	-25	-6	-28	0	-35	-10	-45	-24	-59
120 180	+25	-14	+4	-21	+12	-28	-8	-33	0	-40	-12	-52	-28	-68
180 250	+30	-16	+5	-24	+13	-33	-8	-37	0	-46	-14	-60	-33	-79
250 315	+36	-16	+5	-27	+16	-36	-9	-41	0	-52	-14	-66	-36	-88
315 400	+39	-18	+7	-29	+17	-40	-10	-46	0	-57	-16	-73	-41	-98
400 500	+43	-20	+8	-32	+18	-45	-10	-50	0	-63	-17	-80	-45	-108
500 630	+35	-35	0	-44	0	-70	-26	-70	-26	-96	-44	-114	-78	-148
630 800	+40	-40	0	-50	0	-80	-30	-80	-30	-110	-50	-130	-88	-168
800 1000	+45	-45	0	-56	0	-90	-34	-90	-34	-124	-56	-146	-100	-190
1000 1250	+52	-52	0	-66	0	-105	-40	-106	-40	-145	-66	-171	-120	-225
1250 1600	+62	-62	0	-78	0	-125	-48	-126	-48	-173	-78	-203	-140	-265



Examples of axial locating of bearings with tapered bore seated directly on the tapered journal or by means of an adapter or withdrawal sleeve are in Pict. 13.

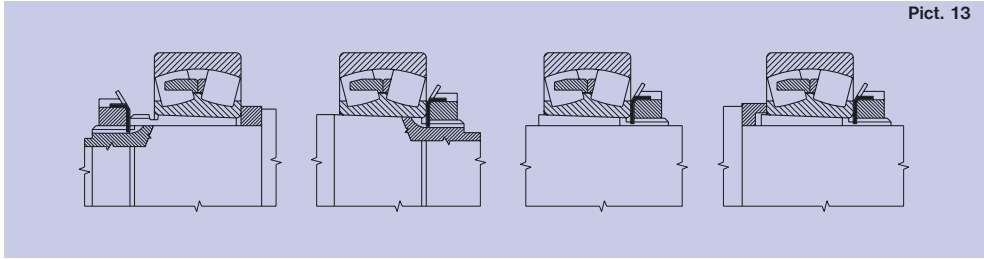

Pict. 13

Permissible bearing axial load fixed by an adapter sleeve on smooth shafts without bearing resting on the shaft shoulder is calculated according to equation:

$$F_a = 3Bd \quad [N]$$

- |       |                                  |      |
|-------|----------------------------------|------|
| $F_a$ | - permissible bearing axial load | [N]  |
| $B$   | - bearing width                  | [mm] |
| $d$   | - bearing bore diameter          | [mm] |

If the axial displacement of the outer ring in the housing is not required, then we can use solution, when the face supporting or seating surface of the bearing cover, nut or snap ring are used. Bearings with grooves for snap ring (NR) do not require much space and their securing is simple. Examples - see Pict. 14.

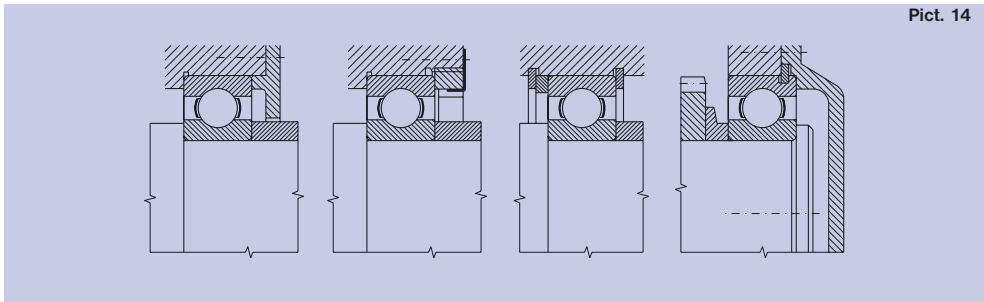

Pict. 14

Abutment dimensions for each bearing shown in this publication are in the dimension tables.

### 3.3 Sealing

Sealing of the bearing space is very important, because damaging materials which can be found in the bearing environment influence it and often can cause its breakdown. Sealing also has an opposite function - it prevents the lubricant leaking out of the bearing and arrangement space. That is why sealing must always be designed with regard to operating conditions of machines or equipments, arrangement design, lubricating method, maintenance possibility and economic questions concerning production and utilization.

#### 3.3.1 Non-Contact Sealing

Between non-rotating and rotating parts there is only a narrow gap when using this sealing. It is filled with grease. Using this sealing, wear of components from friction does not occur and that is why this sealing can be used for the highest rotational speeds and for high operating temperatures. Examples of a gap sealing are in Pict. 15.

Pict. 15

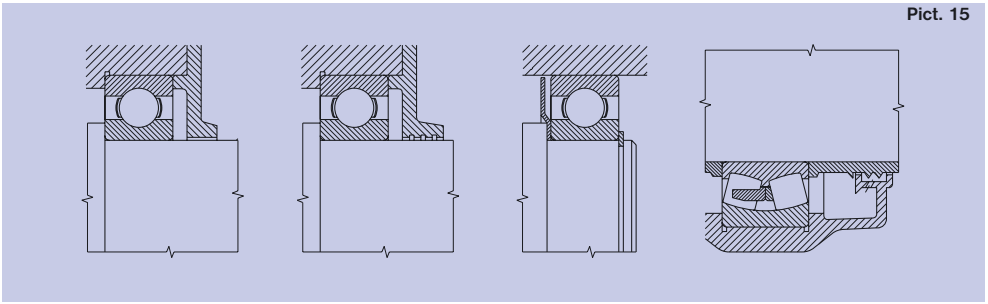

Another very effective sealing is the labyrinth sealing which can improve the sealing effect by a greater number of labyrinths or prolongation of sealing gaps. Examples - see Pict. 16.

Pict. 16

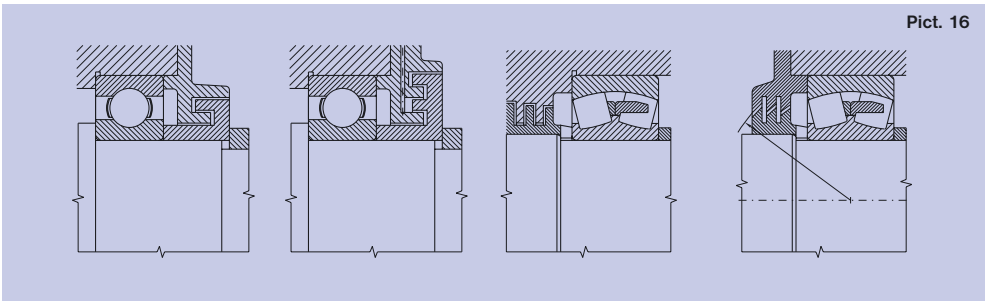

### 3.3.2 Rubbing Sealing

Rubbing sealing is created of elastic or soft, but sufficiently impermeable material, which is inserted between the rotating and firm part. Such a sealing is usually cheap and is suitable for various designs. The disadvantage is the sliding friction of the contacting surfaces, and therefore there is limited utilization for high rotational speeds.

Sealing with a felt ring is the simplest (Pict. 17). It is suitable for operating temperature  $-40^{\circ}$  to  $+80^{\circ}\text{C}$  and for peripheral speeds to  $7\text{ m}\cdot\text{s}^{-1}$  and sliding surface roughness max.  $R_a = 0,16$ , hardness min. 45 HRC or hard chromium plating. Dimensions of the felt rings are given by corresponding national standards.

A very wide-spread way of sealing is sealing with shaft washers (Pict. 18). Radial shaft seal washers are made of rubber or other suitable plastic reinforced by steel sheet reinforcement. According to the material used they are suitable for operating temperature from  $-30^{\circ}$  to  $+80^{\circ}\text{C}$ . Permissible peripheral speed depends on sliding surface roughness:

- to  $2\text{ m}\cdot\text{s}^{-1}$  is roughness max.  $R_a = 0.8$
- to  $4\text{ m}\cdot\text{s}^{-1}$  is roughness max.  $R_a = 0.4$
- to  $12\text{ m}\cdot\text{s}^{-1}$  is roughness max.  $R_a = 0.2$ .

Pict. 17

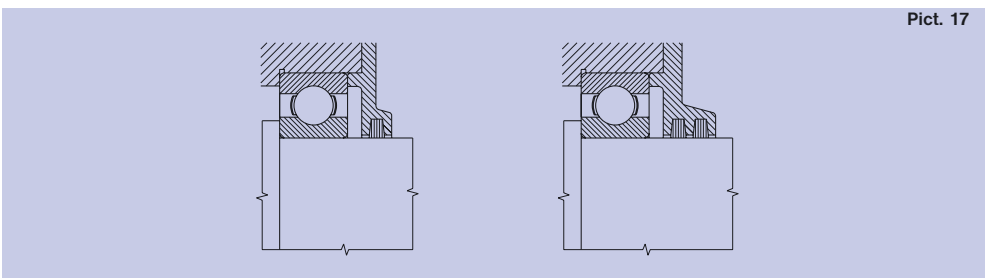

Except for mentioned most commonly used sealing rings there are rubbing sealing designs which use the just formed sealing rings made of rubber, plastic, etc., or special spring rings. This sealing is chosen either for applications with high requirements on bearing space sealing (great environment pollution, high temperature, chemical substance influence), or for economic reasons by mass or series production. Examples – see Pict. 19.

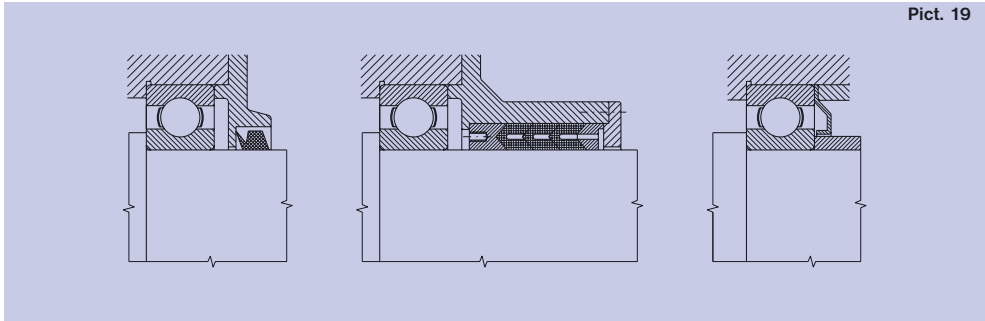
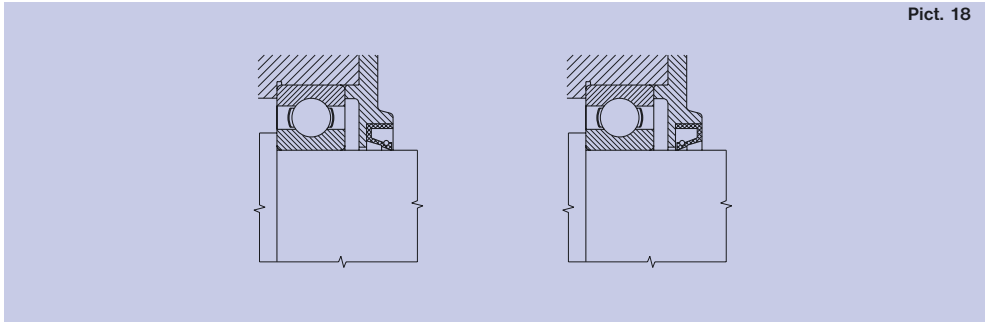

### 3.3.3 Combined Sealing

Increase sealing effect can be reached by non-contact and rubbing sealing combination. Such a sealing is recommended for wet and polluted environment. Example – see Pict. 20.

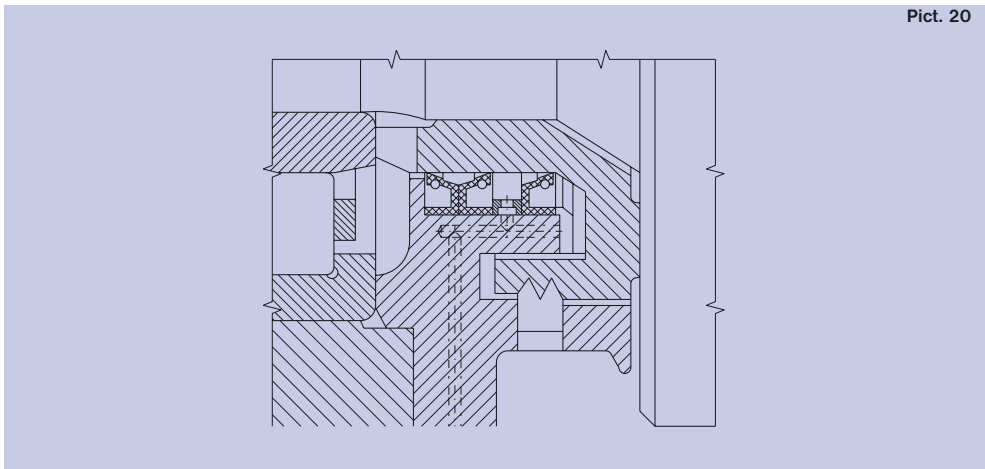

## 4. Bearing Lubrication

The correct bearing lubrication has a direct influence on the bearing life. Lubricant creates between the rolling element and bearing ring a carrying lubricating film which hinders their metal contact. It lubricates surfaces where friction arises, it has cooling effect, it protects the bearing from corrosion and in many cases seals the bearing space.

In the most cases - approximately 90%, bearings are lubricated with grease or oil, in rare exceptions by other lubricating means. When deciding which lubricant and which lubrication type should be used, operating conditions, characteristic qualities of the lubricant, equipment design and operating economy should be taken into account.

### 4.1 Grease Lubrication

In the design practice grease lubrication is preferred to oil lubrication from the point of view of arrangement simplicity, utilization of the sealing capabilities and simple maintenance.

For reliable bearing operation 1/3 to 1/2 of its free space is filled with grease at the first assembly. A greater grease amount has negative influence on the operation. Higher passive resistances cause the inner bearing space warming up undesirably, which can lead to its breakdown. Bearings making only a small number of revolutions during operation, from the point of view of corrosion protection should be completely filled.

#### 4.1.1 Relubrication Interval

Relubrication interval is the period during which the grease has the necessary lubricating properties. After this period bearing must be relubricated, and old lubricant must be removed from the bearing space completely.

Relubricating period depends on the bearing type and size, rotational speed, operating temperature and grease quality. The recommended relubrication period for individual bearing types at normal load ( $P \leq 0.15 C$ ) and normal operational conditions is shown in diagrams in Pict. 21 and 22. The diagrams are valid for common greases and temperatures to +70°C. For temperatures over +70 °C, the relubrication period is shortened for each 15 °C on the half of original value. For temperatures under +40 °C the relubrication period can be doubled.

For small sized, especially single row ball bearings, the relubrication periods are several times longer than the bearing life, that is why the bearings are, as a rule, not relubricated.

For this reason it is advantageous to use these bearings shielded or sealed on both sides and filled with grease. For some rotational speeds the relubrication period is out of the diagram curve, i.e. the permissible limit for grease lubrication has been reached and oil lubrication should be used.

Necessary grease quantity for relubrication is calculated from the equation:

$$Q = 0,005 DB \quad [g]$$

Q – grease quantity	[g]
D – bearing outer diameter	[mm]
B – bearing width	[mm]

For bearings with higher rotational speed requiring a more frequent relubrication, it is necessary to remove the used lubrication from the bearing space so that temperature increase should not occur. For this reason the grease escape valve is suitable.

#### 4.1.2 Bearing Greases

Bearing greases are produced most often of quality mineral or synthetic oils (sometimes with additives), thickened with fatty acid metallic soaps. Greases must have good lubricating properties and high chemical, temperature and mechanical stability. The grease list of bearing lubricants is in Table 36.

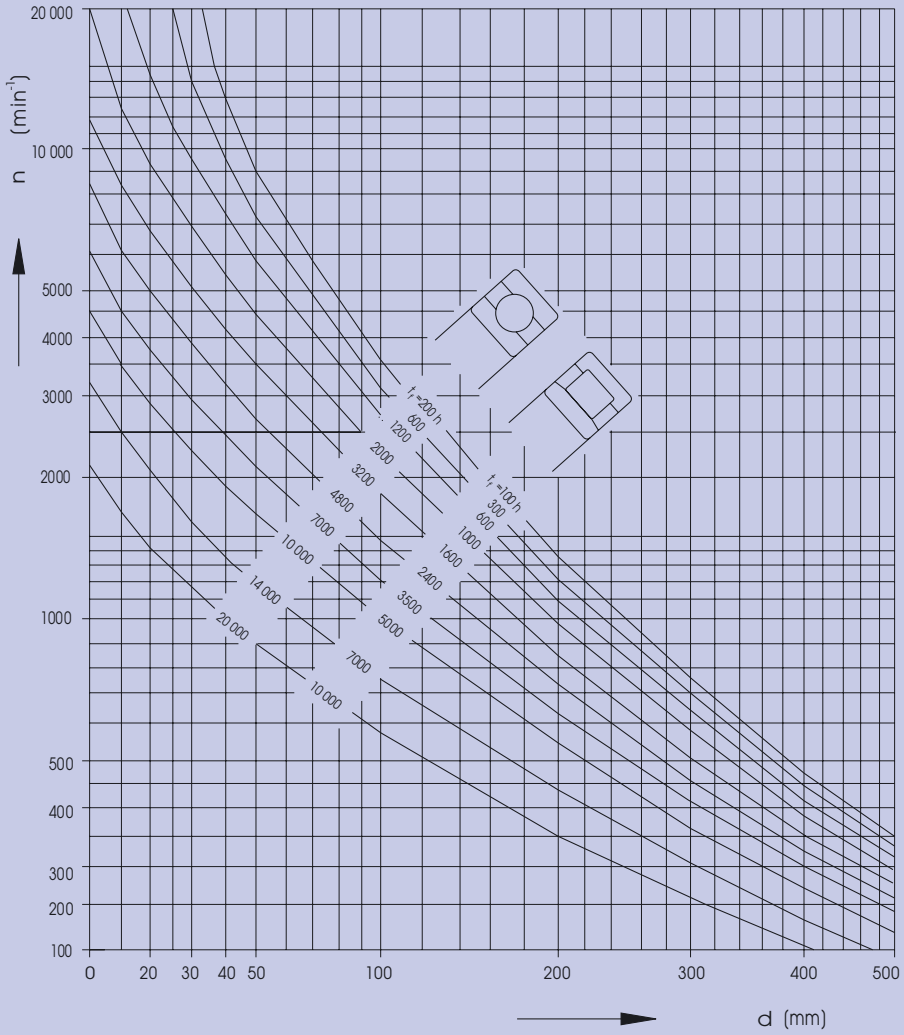

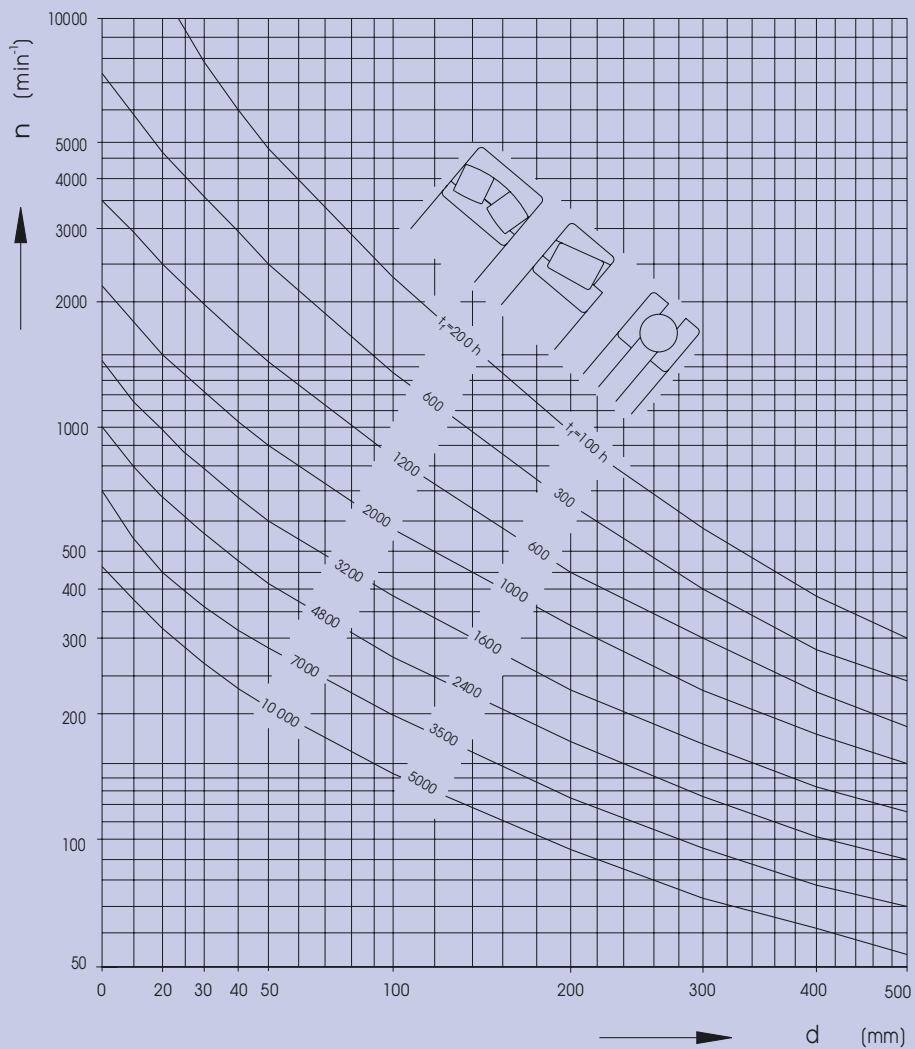

Rolling Bearing Grease Properties			Table 36	
Kind of Grease		Properties		
Thickening Agent	Basic Oil	Operating Temperature Extent [°C]	Water	Resistance against
lithium soap	mineral	-20 ÷ 130	resistant	multi-purpose lubricant
lime soap	mineral	-20 ÷ 50	high resistance	good sealing effect against water
soda soap	mineral	-20 ÷ 100	irresistant	emulsifies with water
aluminium soap	mineral	-20 ÷ 70	resistant	good sealing effect against water
complex lithium soap	mineral	-20 ÷ 150	resistant	multi-purpose lubricant
complex lime soap	mineral	-30 ÷ 130	high resistance	multi-purpose lubricant suitable for higher temperatures and load
complex soda soap	mineral	-20 ÷ 130	resistant	suitable for higher temperature and load
complex aluminium soap		-20 ÷ 150	mineral	suitable for higher temperature and load
complex barium soap	mineral	-30 ÷ 140	resistant	suitable for higher temperature and load
bentonite	mineral		resistant	suitable for high temperatures at low rotational speed
polyurea	mineral	-20 ÷ 160	resistant	suitable for high temperatures at medium rotational speed
lithium soap	silicon	-40 ÷ 170	high resistance	suitable for wide temperature range at medium rotational speed
speed complex barium soap	ester	-60 ÷ 140	resistant	suitable for higher temperatures and higher rotational speeds

## 4.2 Oil Lubrication

Oil lubrication is used, when operating rotational speed is so high that the grease relubrication period is too short. Another reason can also be the necessity of heat transfer from the bearing, or the high temperature of environment, which does not enable utilization of grease, or if surrounding parts are already lubricated by oil (e.g. geared wheels in the gear box). Except for some cases, spherical roller thrust bearings are always lubricated by oil.

When oil lubricating, lubricating must be secured both at starting and during operation. Excess oil increases temperature and bearing temperature.

Oil feed into bearing is secured in various design ways, out of which oil bath lubrication with oil level reaching middle of the lowest rolling element, oil circulation lubrication, jet lubrication, oil mist lubrication etc., are the most common.

### 4.2.1 Bearing Oils

For bearing lubrication mostly refined oils with good chemical stability which can be improved by antioxidizing agents are used.

The decisive oil property is kinematic viscosity which decreases with increasing temperature. Suitable oil viscosity  $\nu_1$  can be stated according to the diagram in Pict. 23 in dependence on the bearing mean diameter  $d_s = (d+D)/2$  and rotational speed  $n$ . If the operating temperature is known or it can be found out, according to the diagram in Pict. 24 suitable oil and viscosity  $\alpha$  at internationally standardized temperature 40 °C being necessary for calculation of ratio  $\alpha$  is determined.

By ratio  $\alpha < 1$  it is recommended to use EP oil with additives which improve the oil film load rating. By value  $\alpha$  decrease under 0.4 oils with EP additives are always used.

If the ratio  $\alpha$  is greater than 1, improved arrangement reliability is reached in operation.

Example:

- bearing  $d = 180$  mm,  $D = 320$  mm,  $d_s = 250$  mm
- rotational speed  $n = 500$  min<sup>-1</sup>
- presumed operating temperature 60 °C

For these conditions according to diagram in Pict. 23 the minimum kinematic viscosity is  $\nu_1 = 17$  mm<sup>2</sup>.s<sup>-1</sup>.

If the operating temperature is 60 °C, the oil selected according to the diagram in Pict. 24 at standardized temperature 40 °C must have kinematic viscosity  $\nu$  min. 35 mm<sup>2</sup>.s<sup>-1</sup>.

For thrust spherical roller bearings the lubricating oil kinematic viscosity is approximately stated in dependence on  $n \times d$ , where  $n$  is the bearing rotational speed in revolutions per minute and  $d$  is the bore diameter in mm, according to table 37. Lower values are valid for bearings with lower load, for which is valid  $P_a \leq 0,1 C_a$ . Higher values are valid for  $P_a > 0,1 C_a$ .

Oil Viscosity for Spherical Roller Thrust Bearings		Table 37
d.n	Kinematic Oil Viscosity	
	mm <sup>2</sup> .s <sup>-1</sup> at 40°C	
1 000	250 to 550	
10 000	100 to 250	
100 000	45 to 100	
200 000	30 to 80	

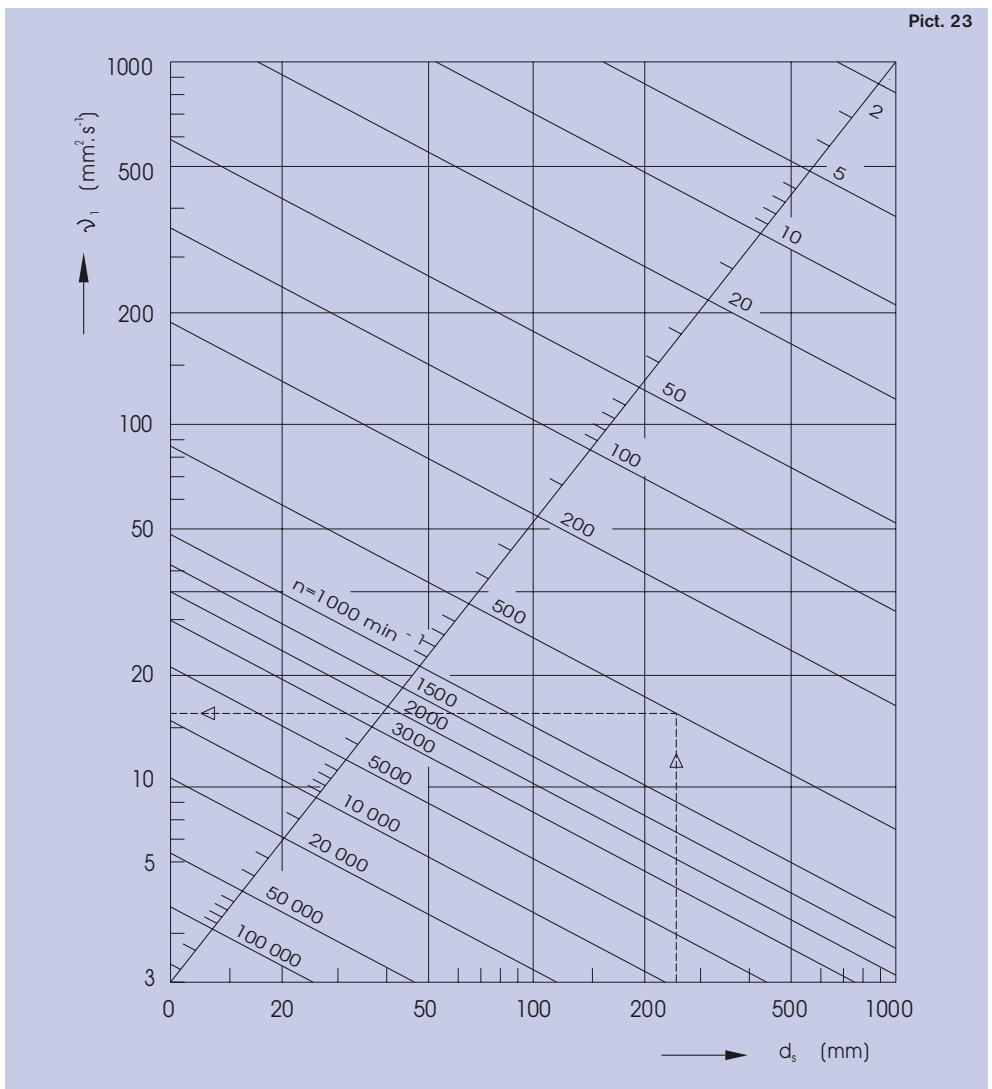



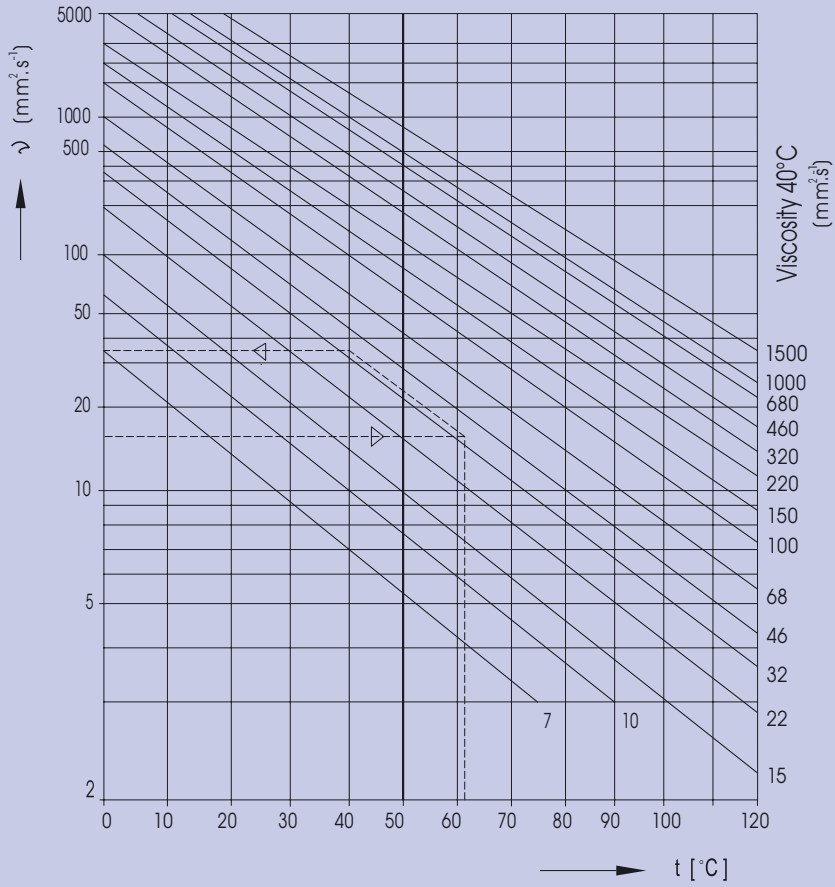

### 4.3 Lubrication with Solid Lubricants

Solid lubricants are used for bearing lubrication when the grease or oil cannot fulfil the requirements for reliable lubrication in conditions of limiting friction or from the viewpoint of high operating temperatures, chemical influences, etc.

## 5. Mounting and Dismounting of Rolling Bearings

A very important requirement besides using the suitable mounting or dismounting tool is to make sure these tools are clean and the whole operation can be carried out in clean working environment. If this is not fulfilled, the impurities have decisive influence on the bearing behaviour in operation and can also cause bearing breakdown. In the same way the cleanliness conditions must be fulfilled by the preparation of all lubricating means and components connected with the arrangement.

New bearings are preserved by manufacturer with preservatives which need not be removed before mounting. Bearings should be taken out just before mounting. Rarely the preservative is removed from the bearing. For this operation are used:

- gas with 5 to 10% oil additive
- benzol
- diesel fuel
- water-free oil

After washing the bearing should be oiled, preserved from pollution and mounted as soon as possible.

Before mounting, the seating surfaces dimensions should be checked for cleanliness or damage.

### Mounting of Bearings with Cylindrical Bore

Bearings with cylindrical bore are mounted on the shaft at room temperature or heated. Dimensionally smaller bearings are mostly mounted at room temperature.

The force necessary for mounting is reached by hammer blows or more suitably by press. In both cases mounting jig is used. At mounting it is not permissible to transfer the mounting force through rolling elements. That is why the jig must always be placed on the ring or both rings being mounted while the mounting force is acting.

Heat mounting is used for greater bearings whose rings are fitted with a greater interference. Maximum heating temperature of the bearing is 100 °C.

### Mounting of Bearings with Tapered Bore

Bearings with a tapered bore are mounted on the shaft by means of adapter or withdrawal sleeves or are seated directly on the tapered journal. Reliable mounting is reached either by pressing the inner ring by a nut, or by sufficient inserting of the sleeve. In both cases the inner ring expands and bearing radial clearance decreases.

When mounting double row self aligning ball bearings the adapter sleeve nut can be tightened, but only to such an extent that the outer ring can be easily turned and swivelled.

A double row spherical roller bearing is mounted with a greater interference. Mounting reliability is checked according to radial clearance reduction by means of feeler gauges or measuring the axial displacement of the inner ring on the journal or tapered sleeve. Initial position for measuring this displacement is reached, when the contact surfaces (of the ring, sleeve, shaft) seat on each other on the whole seating surface. Values for mounting double row spherical roller bearings with tapered bore are shown in table 38.

Mounting of Double Row Spherical Roller Bearings with Tapered Bore

Table 38

Bore Diameter		Radial Clearance Reduction		Axial Displacement on Taper 1: 12				Bearing Minimum Permissible Radial Clearance		
d over	to	min	max	on Shaft		on Sleeve		normal	with Clearance C3	with Clearance C4
				min	max	min	max			
mm		µm		mm				µm		
30	40	20	25	0,35	0,4	0,35	0,45	15	20	40
40	50	25	30	0,4	0,45	0,45	0,5	20	30	50
50	65	30	40	0,45	0,6	0,5	0,7	25	35	55
65	80	40	50	0,6	0,75	0,7	0,85	25	40	70
80	100	45	60	0,7	0,9	0,75	1	35	50	80
100	120	50	70	0,75	1,1	0,8	1,2	50	65	100
120	140	65	90	1,1	1,4	1,2	1,5	55	80	110
140	160	75	100	1,2	1,6	1,3	1,7	55	90	130
160	180	80	110	1,3	1,7	1,4	1,9	60	100	150
180	200	90	130	1,4	2	1,5	2,2	70	100	160
200	225	100	140	1,6	2,2	1,7	2,4	80	120	180
225	250	110	150	1,7	2,4	1,8	2,6	90	130	200
250	280	120	170	1,9	2,7	2	2,9	100	140	220
280	315	130	190	2	3	2,2	3,2	110	150	240
315	355	150	210	2,4	3,3	2,6	3,6	120	170	260
355	400	170	230	2,6	3,6	2,9	3,9	130	190	290
400	450	200	260	3,1	4,1	3,4	4,4	130	200	310
450	500	210	280	3,3	4,4	3,6	4,8	160	230	350
500	560	240	320	3,7	5	4,1	5,4	170	250	360
560	630	260	350	4	5,4	4,4	5,9	200	290	410
630	710	300	400	4,6	6,2	5,1	6,8	210	310	450
710	800	340	450	5,3	7	5,8	7,6	230	350	510
800	900	370	500	5,7	7,8	6,3	8,5	270	390	570

# Rolling Bearings Dimension Tables

Single Row Deep Groove Ball Bearings	
Single Row Angular Contact Ball Bearings	
Double Row Angular Contact Ball Bearings	
Double Row Self-Aligning Ball Bearings	
Single Row Cylindrical Roller Bearings	
Double Row Cylindrical Roller Bearings	
Single Row Needle Roller Bearings	
Double Row Spherical Roller Bearings	
Tapered Roller Bearings	
Thrust Ball Bearings	
Spherical Roller Thrust Bearings	
Insert Ball Bearing Units	
Spherical Plain Bearings	
Accessories of Rolling Bearings	
Rolling Elements	
Special Rolling Bearings	

# Single Row Deep Groove Ball Bearings

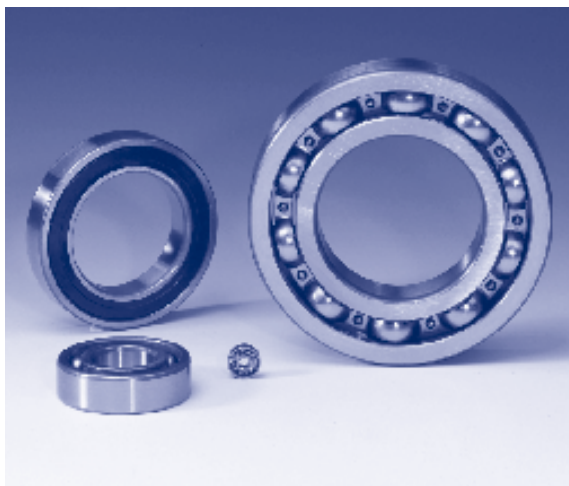

Single row deep groove ball bearings are the most common bearing type and are designed as non-separable and are without a filling slot. Good conformity to raceways is achieved by optimum size and number of balls and relatively high load ratings are achieved. They accommodate both radial and axial loads in both directions and are suitable for high rotational speeds.

Outer ring design of separable single row ball bearings - type E and BO enables separate mounting of inner ring with cage and rolling elements. The bearings are produced from bore diameter  $d = 20$  mm and are suitable for smaller loads and high-rotational applications.

## Boundary Dimensions

Boundary dimensions except for separable single row ball bearings - type E and BO correspond to the standard ISO 15.

Snap ring groove dimensions comply with the standard ISO 464.

## Designation

Bearing designation in standard design and common modifications (Z, RS, ZZ, ZRS, N) are shown in the dimension tables. Deviation from standard design is designated by prefixes and suffixes (section 2.2).

## Shielded or Sealed Bearings

Single row deep groove ball bearings with shields or seals on one or both sides are produced with metal shields (Z, ZZ, ZR, ZZR) or seals (RS, ZRS, RSR, ZRSR) as non-separable units.

The shields create a non-contact sealing. Sealing rings are made of rubber, vulcanized on a metal reinforcing ring and act in the bearing as an effective friction type sealing.

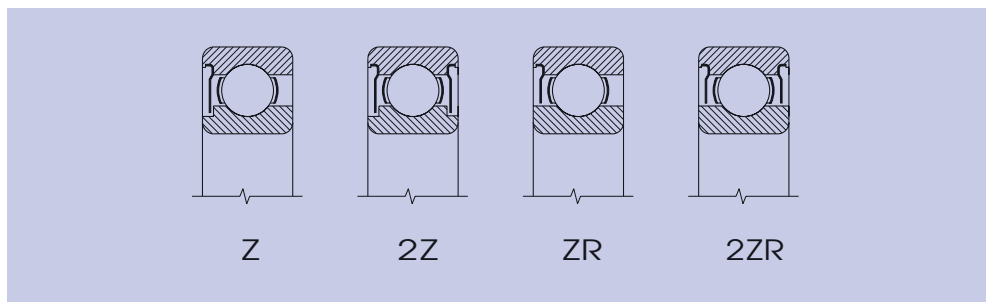

Bearings with sealings on both sides are filled with grease which assures reliable lubricating conditions for the whole bearing life. These bearings are suitable for temperature ranges

of -30°C to +110°C. Delivery of bearings with another grease must be agreed with the supplier in advance.

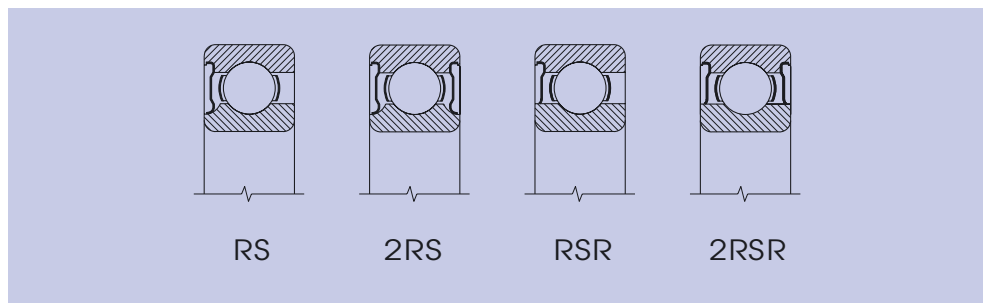

### Bearings with Snap Ring Groove

For simple securing against axial displacement in the housing single row ball bearings with snap groove on outer ring are manufactured (N). When the bearing is delivered with inserted snap ring, it is designated (NR). Bearings with a snap ring groove can also be delivered with assembled seals.

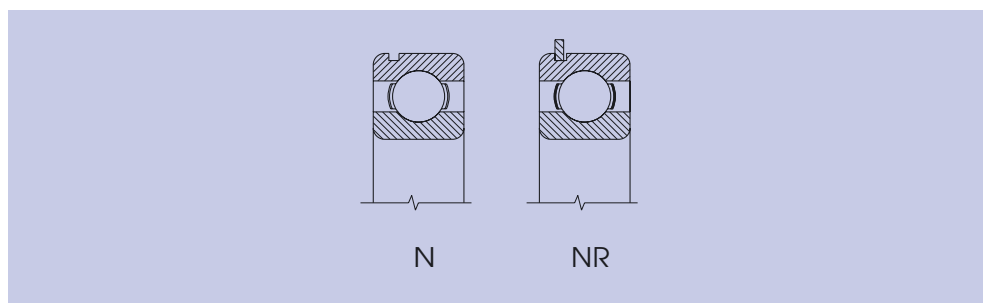

### Cage

Single row ball bearings in standard design usually have a cage according to the table. Material symbol (J, Y, M, F) and design of the cage are not mostly indicated.

Bearings with Pressed Steel or Brass Cage	Bearings with Machined Brass or Steel Cage
d<10mm (619/2 to 629) <sup>1)</sup>	-
-	61926
16001 to 16030	-
6000 to 6034	6036 to 6040
6200 to 6230	6232 to 6240
6300 to 6324	6326 to 6330
6403 to 6417	6418
E15 to E20, BO17	-

1) Bearing 618/8 is made with a solid cage made of polyamide (TNH)

For special arrangements bearings with different cages made of various materials are produced: polyamide (TNH, TNB) and textite (TB). Using of these bearings should be discussed in advance.

### Tolerance

Single row ball bearings are produced in normal tolerance class P0, this symbol is not indicated. Limiting values for dimension and operation accuracy comply with the standard ISO 199 and ISO 492. Exceptions are only separable single row ball bearings - type E and BO, outer diameter of which has limiting deviation  $D +0.01/0.00$  mm.

## Radial Clearance

Single row ball bearings delivered without radial clearance designation are produced with normal radial clearance. Radial clearance values comply with the standard ISO 5753.

## Vibration Level

Commonly manufactured single row ball bearings have a normal vibration level checked by the manufacturer. Bearings in tolerance class P5 and higher have the vibration level C6. For special arrangements bearings with reduced vibration level C6, C06 and C66 are produced.

## Tapered Bore

For some less demanding arrangements some sizes of single row ball bearings - type 62 and 63 with tapered bore, taper 1:12 can be produced. Fixing of bearings on the cylindrical journal is made by means of adapter sleeves or directly on the tapered journal.

## Bearings for Arrangements at High Operating Temperatures

For arrangements working at operating temperature to 400°C single row bearings with adequately great radial clearance according to technical conditions between producer and customer are delivered.

These bearings have reduced basic dynamic load rating in average of 50% and basic static load rating of 30% in comparison with bearings in standard design.

## Misalignment

For single row ball bearings only small mutual misalignment of bearing rings is permissible, therefore alignment deviation of seating surfaces can be very small. Misalignment causes additional loading of the bearing and thus its life is shortened.

Values of permissible misalignment at normal operating conditions are shown in the table.

Bearing Type	Load light ( $F_r < 0.15C_{or}$ )	heavy ( $F_r \geq 0.15C_{or}$ )
	618, 619, 160, 60 62, 63, 64	2' to 6' 5' to 10'

## Radial Equivalent Dynamic Load

Single Row Ball Bearings

$$P_r = X F_r + Y F_a \quad [\text{kN}]$$

$\frac{F_a}{C_{or}}$	Radial Clearance														
	normal					C3					C4				
	e	$F_a/F_r \leq e$		$F_a/F_r > e$		e	$F_a/F_r \leq e$		$F_a/F_r > e$		e	$F_a/F_r \leq e$		$F_a/F_r > e$	
	X	Y	X	Y	X	Y	X	Y	X	Y	X	Y	X	Y	
0.025	0.22	1	0	0.56	2.0	0.31	1	0	0.46	1.75	0.40	1	0	0.44	1.42
0.040	0.24	1	0	0.56	1.8	0.33	1	0	0.46	1.62	0.42	1	0	0.44	1.36
0.070	0.27	1	0	0.56	1.6	0.36	1	0	0.46	1.46	0.44	1	0	0.44	1.27
0.130	0.31	1	0	0.56	1.4	0.41	1	0	0.46	1.30	0.48	1	0	0.44	1.16
0.250	0.37	1	0	0.56	1.2	0.46	1	0	0.46	1.14	0.53	1	0	0.44	1.05
0.500	0.44	1	0	0.56	1.0	0.54	1	0	0.46	1.00	0.56	1	0	0.44	1.00





Factor X and Y values are valid, if the bearings on the journal and in the housing will be fitted in tolerances recommended for small and medium loads (tables 28 and 29) and during operation significant reduction of radial clearance due to operating temperature does not come into being (temperature gradient between inner and outer ring max. 10°C).

**Separable Single Row Ball Bearings:**

$$\begin{array}{lll} P_r = F_r & \text{for } F_a / F_r \leq 0.2 & [\text{kN}] \\ P_r = 0.5 F_r + 2.5 F_a & \text{for } F_a / F_r > 0.2 & [\text{kN}] \end{array}$$

**Radial Equivalent Static Load :**

**Single Row Deep Groove Ball Bearings :**

$$P_{or} = 0.6F_r + 0.5F_a \quad (P_{or} \cong F_r) \quad [\text{kN}]$$

**Separable Single Row Ball Bearings:**

$$P_{or} = 0.9F_r + 0.3F_a \quad (P_{or} \cong F_r) \quad [\text{kN}]$$

# Single Row Deep Groove Ball Bearings

d = 2 to 17 mm

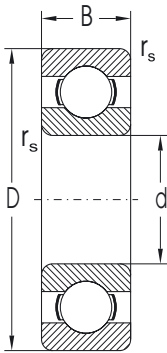

Dimensions				Basic Load Dynamic C <sub>r</sub>	Rating Static C <sub>0r</sub>	Fatigue load limit P <sub>v</sub>	Limiting Speed for Lubrication with		Bearing Designation
d	D	B	r <sub>s</sub> min				Grease	Oil	
mm				kN		kN		min <sup>-1</sup>	
2	6	2.3	0.10	0.279	0.090	0.004	63000	79000	<b>619/2</b>
3	10	4.0	0.15	0.645	0.229	0.010	40000	50000	<b>623</b>
4	13	5.0	0.20	1.168	0.412	0.019	38000	45000	<b>624</b>
	16	5.0	0.30	1.875	0.677	0.031	35000	42000	<b>634</b>
5	13	4.0	0.20	1.079	0.432	0.020	47000	56000	<b>619/5</b>
	16	5.0	0.30	1.875	0.677	0.031	35000	42000	<b>625</b>
	19	6.0	0.30	2.838	1.078	0.049	35000	42000	<b>635</b>
6	15	5.0	0.20	1.470	0.599	0.027	42000	50000	<b>619/6</b>
	19	6.0	0.30	2.838	1.078	0.049	35000	42000	<b>626</b>
7	19	6.0	0.30	2.838	1.078	0.049	35000	42000	<b>607</b>
	22	7.0	0.30	3.282	1.356	0.062	35000	42000	<b>627</b>
8	16	4.0	0.20	1.550	0.722	0.033	35000	42000	<b>618/8TNH</b>
	22	7.0	0.30	3.282	1.356	0.062	35000	42000	<b>608</b>
9	24	7.0	0.30	3.668	1.640	0.075	35000	42000	<b>609</b>
	26	8.0	0.30	4.557	1.955	0.089	35000	42000	<b>629</b>
10	26	8.0	0.30	4.557	1.955	0.089	28000	33000	<b>6000</b>
	30	9.0	0.60	6.047	2.510	0.114	25000	30000	<b>6200</b>
	30	14.0	0.60	6.047	2.510	0.114	25000	30000	<b>62200</b>
	35	11.0	0.60	8.072	3.430	0.156	22000	27000	<b>6300</b>
12	28	7.0	0.30	5.094	2.360	0.107	25000	30000	<b>16001</b>
	28	8.0	0.30	5.094	2.360	0.107	25000	30000	<b>6001</b>
	32	10.0	0.60	6.905	3.100	0.141	22000	27000	<b>6201</b>
	32	14.0	0.60	6.905	3.100	0.141	22000	27000	<b>62201</b>
	37	12.0	1.00	9.759	4.235	0.193	20000	24000	<b>6301</b>
15	32	8.0	0.30	5.594	2.860	0.130	21000	25000	<b>16002</b>
	32	9.0	0.30	5.594	2.865	0.130	21000	25000	<b>6002</b>
	35	11.0	0.60	7.718	3.745	0.170	20000	24000	<b>6202</b>
	35	14.0	0.60	7.718	3.745	0.170	20000	24000	<b>62202</b>
	42	13.0	1.00	11.310	5.330	0.242	18000	21000	<b>6302</b>
17	35	8.0	0.30	5.999	3.265	0.148	20000	24000	<b>16003</b>
	35	10.0	0.30	6.001	3.267	0.149	20000	24000	<b>6003</b>
	40	12.0	0.60	9.534	4.734	0.215	18000	21000	<b>6203</b>
	40	16.0	0.60	9.534	4.734	0.215	18000	21000	<b>62203</b>
	47	14.0	1.00	13.565	6.560	0.298	16000	19000	<b>6303</b>

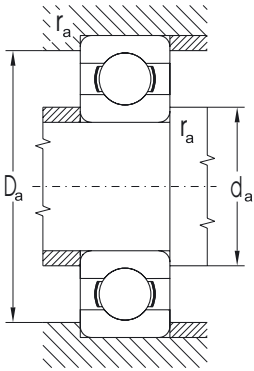

Abutment and Fillet Dimensions				Weight
d	d <sub>a</sub> min	D <sub>a</sub> max	r <sub>a</sub> max	~
mm				kg
2	3.2	4.8	0.1	0.0004
3	4.2	8.5	0.1	0.0015
4	5.6	11.2	0.2	0.0032
	6.2	13.4	0.3	0.0050
5	6.6	11.5	0.2	0.0025
	7.0	14.0	0.3	0.0047
	7.2	15.8	0.3	0.0090
6	7.8	13.0	0.2	0.0040
	8.2	17.0	0.3	0.0080
7	9.0	17.2	0.3	0.0090
	9.2	19.0	0.3	0.0123
8	9.8	14.0	0.2	0.0030
	10.0	20.0	0.3	0.0150
9	11.0	22.0	0.3	0.0180
	11.0	24.0	0.3	0.0200
10	12.0	24.0	0.3	0.0190
	14.0	26.0	0.6	0.0310
	14.0	26.0	0.6	0.0400
	14.0	31.0	0.6	0.0540
12	14.0	26.0	0.3	0.0200
	14.0	26.0	0.3	0.0220
	16.0	28.0	0.6	0.0370
	16.0	28.0	0.6	0.0450
	17.0	32.0	1.0	0.0610
16	17.0	30.0	0.3	0.0270
	17.0	30.0	0.3	0.0300
	19.0	31.0	0.6	0.0460
	19.0	31.0	0.6	0.0540
	20.0	36.0	1.0	0.0850
17	19.0	33.0	0.3	0.0320
	19.0	33.0	0.3	0.0400
	21.0	36.0	0.6	0.0730
	21.0	36.0	0.6	0.0830
	23.0	41.0	1.0	0.1150

# Single Row Deep Groove Ball Bearings

d = 20 to 50 mm

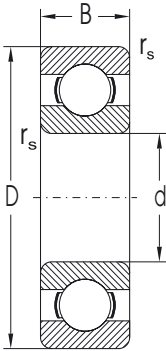

Dimensions				Basic Load Dynamic C <sub>r</sub>	Rating Static C <sub>0r</sub>	Fatigue load limit P <sub>v</sub>	Limiting Speed for Lubrication with		Bearing Designation
d	D	B	r <sub>s</sub> min				Grease	Oil	
mm				kN		kN	min <sup>-1</sup>		
20	42	8.0	0.30	9.371	4.972	0.226	17000	20000	<b>16004D</b>
	42	12.0	0.60	9.371	4.972	0.226	17000	20000	<b>6004</b>
	47	14.0	1.00	12.774	6.553	0.298	15000	18000	<b>6204</b>
	47	18.0	1.00	12.774	6.553	0.298	15000	18000	<b>62204</b>
	47	20.6	1.00	12.774	6.553	0.298	15000	18000	<b>63204</b>
	52	15.0	1.10	15.866	7.811	0.355	14000	17000	<b>6304</b>
	52	21.0	1.10	15.866	7.811	0.355	14000	17000	<b>62304</b>
25	47	8.0	0.30	6.950	4.550	0.207	14000	17000	<b>16005</b>
	47	8.0	0.30	10.070	5.806	0.264	14000	17000	<b>16005D</b>
	47	12.0	0.60	10.070	5.806	0.264	14000	17000	<b>6005</b>
	52	15.0	1.00	14.029	7.940	0.361	12000	15000	<b>6205</b>
	52	18.0	1.00	14.029	7.940	0.361	12600	15000	<b>62205</b>
	62	17.0	1.10	21.123	10.806	0.491	11000	13000	<b>6305</b>
	62	24.0	1.10	21.123	10.806	0.491	11000	13000	<b>62305</b>
	80	21.0	1.50	36.000	19.200	0.873	9400	11000	<b>6405</b>
30	55	9.0	0.30	11.200	7.360	0.335	12000	14000	<b>16006</b>
	55	13.0	1.00	13.243	8.250	0.375	12000	14000	<b>6006</b>
	62	16.0	1.00	19.443	11.186	0.508	11000	13000	<b>6206</b>
	62	20.0	1.00	19.443	11.186	0.508	11000	13000	<b>62206</b>
	72	19.0	1.10	29.701	15.678	0.713	10000	12000	<b>6306</b>
	90	23.0	1.50	43.000	23.700	1.077	8400	10000	<b>6406</b>
35	62	9.0	0.30	9.960	7.362	0.335	10600	12600	<b>16007</b>
	62	14.0	1.00	15.956	10.328	0.469	10600	12600	<b>6007</b>
	72	17.0	1.10	25.663	15.227	0.692	9400	11000	<b>6207</b>
	80	21.0	1.50	33.367	19.230	0.874	8400	10000	<b>6307</b>
	100	25.0	1.50	55.200	31.000	1.409	7500	8900	<b>6407</b>
40	68	9.0	0.30	12.667	9.617	0.437	9400	11000	<b>16008</b>
	68	15.0	1.00	16.824	11.493	0.522	9400	11000	<b>6008</b>
	80	18.0	1.10	32.633	19.887	0.904	8400	10000	<b>6208</b>
	90	23.0	1.50	40.760	24.170	1.099	7900	9400	<b>6308</b>
	110	27.0	2.00	63.100	36.200	1.645	6700	7900	<b>6408</b>
45	75	10.0	0.60	15.659	12.172	0.553	8400	10000	<b>16009</b>
	75	16.0	1.00	21.100	15.300	0.695	8400	10000	<b>6009</b>
	85	19.0	1.10	32.678	20.325	0.924	7900	9400	<b>6209</b>
	100	25.0	1.50	52.804	31.715	1.442	7100	8400	<b>6309</b>
	120	29.0	2.00	76.500	44.700	2.032	6000	7100	<b>6409</b>
50	80	10.0	0.60	16.092	13.147	0.598	7900	9400	<b>16010</b>
	80	16.0	1.00	21.720	16.650	0.757	7900	9400	<b>6010</b>
	90	20.0	1.10	35.066	23.226	1.056	7100	8400	<b>6210</b>
	110	27.0	2.00	61.754	37.754	1.716	6300	7500	<b>6310</b>
	130	31.0	2.10	87.400	52.100	2.368	5600	6700	<b>6410</b>

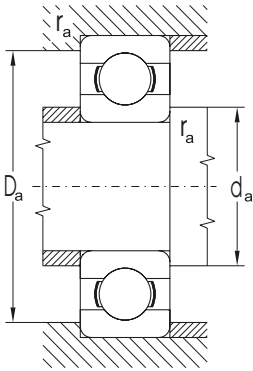

Abutment and Fillet Dimensions				Weight
d	d <sub>a min</sub>	D <sub>a max</sub>	r <sub>a max</sub>	~
mm				kg
20	22.0	40.0	0.3	0.0500
	24.0	38.0	0.6	0.0700
	25.0	42.0	1.0	0.1080
	25.0	42.0	1.0	0.1300
	25.0	42.0	1.0	0.1460
	26.0	45.0	1.0	0.1450
25	26.0	45.0	1.0	0.2000
	27.0	43.0	0.3	0.0530
	27.0	43.0	0.3	0.0530
	28.0	43.0	0.6	0.0820
	30.0	47.0	1.0	0.1290
	30.0	47.0	1.0	0.1500
	31.0	55.0	1.0	0.2300
	31.0	55.0	1.0	0.3200
30	34.0	70.0	1.5	0.5300
	32.0	53.0	0.3	0.0870
	34.0	50.0	1.0	0.1190
	35.0	57.0	1.0	0.2000
	35.0	57.0	1.0	0.2400
	36.0	65.0	1.0	0.3310
35	39.0	80.0	1.5	0.7250
	37.0	60.0	0.3	0.1110
	39.5	57.0	1.0	0.1540
	42.0	65.0	1.0	0.2840
	42.0	71.0	1.5	0.4470
40	44.0	90.0	1.5	0.9540
	42.0	62.0	0.3	0.1250
	44.0	63.0	1.0	0.1910
	47.0	73.0	1.0	0.3490
	47.0	81.0	1.5	0.6250
45	50.0	97.0	2.0	1.1230
	49.0	71.0	1.0	0.1700
	49.0	70.0	1.0	0.2410
	52.0	78.0	1.0	0.4040
	52.0	91.0	1.5	0.8280
50	55.0	107.0	2.0	1.5400
	54.0	76.0	0.6	0.1880
	54.0	75.0	1.0	0.2600
	57.0	83.0	1.0	0.4600
	60.0	100.0	2.0	1.0600
	63.0	116.0	2.0	1.8900

# Single Row Deep Groove Ball Bearings

d = 55 to 90 mm

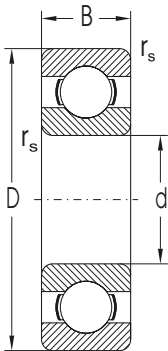

Dimensions				Basic Load Dynamic C <sub>r</sub>	Rating statická C <sub>or</sub>	Fatigue load limit P <sub>v</sub>	Limiting Speed for Lubrication with		Bearing Designation	
d	D	B	r <sub>s</sub> min				Grease	Oil		
mm				kN		kN	min <sup>-1</sup>			
55	90	18.0	1.10	28.216	21.318	0.969	7100	8400	<b>6011</b>	
	100	21.0	1.50	43.350	29.397	1.336	6700	7900	<b>6211</b>	
	120	29.0	2.00	71.000	44.700	2.032	5600	6700	<b>6311</b>	
	140	33.0	2.10	100.000	61.900	2.814	5300	6300	<b>6411</b>	
60	95	18.0	1.10	29.343	23.256	1.057	6700	7900	<b>6012</b>	
	110	22.0	1.50	52.846	35.786	1.627	6000	7100	<b>6212</b>	
	130	31.0	2.10	81.500	52.100	2.368	5300	6300	<b>6312</b>	
	150	35.0	2.10	110.000	69.400	3.079	4700	5600	<b>6412</b>	
65	100	11.0	0.60	21.200	19.600	0.891	6300	7500	<b>16013</b>	
	100	18.0	1.10	30.500	25.100	1.141	6300	7500	<b>6013</b>	
	120	23.0	1.50	57.210	40.011	1.819	5300	6300	<b>6213</b>	
	140	33.0	2.10	92.600	59.600	2.676	5000	6000	<b>6313</b>	
65	160	37.0	2.10	117.950	78.329	3.357	4500	5300	<b>6413</b>	
	70	110	13.0	0.60	27.600	25.100	1.141	5600	6700	<b>16014</b>
		110	20.0	1.10	37.960	30.959	1.407	5600	6700	<b>6014</b>
		125	24.0	1.50	62.000	43.800	1.991	5300	6300	<b>6214</b>
150		35.0	2.10	104.000	63.100	2.735	4700	5600	<b>6314</b>	
70	180	42.0	3.00	144.000	104.000	4.228	4000	4700	<b>6414</b>	
	75	115	13.0	0.60	28.700	26.600	1.209	5300	6300	<b>16015</b>
		115	20.0	1.10	39.747	33.170	1.508	5300	6300	<b>6015</b>
		130	25.0	1.50	66.179	49.311	2.214	5000	6000	<b>6215</b>
160		37.0	2.10	114.000	76.400	3.204	4200	5000	<b>6315</b>	
75	190	45.0	3.00	152.525	112.922	4.459	3800	4500	<b>6415</b>	
	80	125	14.0	0.60	32.900	31.600	1.419	5000	6000	<b>16016</b>
		125	22.0	1.10	47.500	39.800	1.787	5000	6000	<b>6016</b>
		140	26.0	2.00	72.200	53.100	2.301	4700	5600	<b>6216</b>
170		37.0	2.10	122.850	86.226	3.506	4000	4700	<b>6316</b>	
80	200	48.0	3.00	163.587	124.984	4.801	3500	4200	<b>6416</b>	
	85	130	14.0	0.60	34.100	32.900	1.442	4700	5600	<b>16017</b>
		130	22.0	1.10	49.794	42.609	1.868	4700	5600	<b>6017</b>
		150	28.0	2.00	83.299	63.675	2.670	4200	5000	<b>6217</b>
180		41.0	3.00	132.507	96.069	3.794	3800	4500	<b>6317</b>	
85	210	52.0	4.00	174.000	136.000	5.090	3300	4000	<b>6417</b>	
	90	140	24.0	1.50	58.400	49.200	2.085	4500	5300	<b>6018</b>
		160	30.0	2.00	96.200	70.800	2.878	4000	4700	<b>6218</b>
		190	43.0	3.00	144.000	108.000	4.149	3500	4200	<b>6318</b>
225		54.0	4.00	192.000	158.000	5.723	3200	3800	<b>6418</b>	

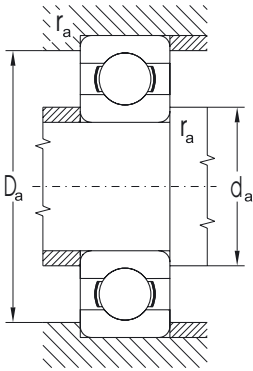

Abutment and Fillet Dimensions				Weight
d	d <sub>a min</sub>	D <sub>a max</sub>	r <sub>a max</sub>	~
mm				kg
55	60.0	84.0	1.0	0.3830
	62.0	91.0	1.5	0.5970
	65.0	110.0	2.0	1.3800
	68.0	126.0	2.0	2.2900
60	65.0	88.0	1.0	0.4110
	67.0	101.0	1.5	0.7710
	72.0	118.0	2.0	1.7200
	73.0	136.0	2.0	2.7600
65	69.0	96.0	0.6	0.3000
	70.0	93.0	1.0	0.4370
	72.0	111.0	1.5	0.9970
	76.0	128.0	2.0	2.1000
70	78.0	146.0	2.0	3.2800
	74.0	106.0	0.6	0.4330
	75.0	103.0	1.0	0.6040
	77.0	116.0	1.5	1.0700
75	81.0	138.0	2.0	2.5400
	85.0	164.0	2.5	4.8500
	79.0	111.0	0.6	0.4570
	80.0	108.0	1.0	0.6380
80	82.0	122.0	1.5	1.1800
	86.0	148.0	2.0	3.0600
	90.0	174.0	2.5	5.7400
	84.0	121.0	0.6	0.5970
85	85.0	118.0	1.0	0.8450
	90.0	130.0	2.0	1.4000
	91.0	158.0	2.0	3.6300
	95.0	184.0	2.5	6.7200
90	89.0	126.0	0.6	0.6260
	90.0	123.0	1.0	0.8920
	95.0	140.0	2.0	1.8000
	98.0	166.0	2.5	4.2000
95	105.0	190.0	3.0	7.8800
	96.0	132.0	1.5	1.1700
	100.0	150.0	2.0	2.1600
	103.0	176.0	2.5	4.9500
100	110.0	205.0	3.0	11.4000

# Single Row Deep Groove Ball Bearings

d = 95 to 170 mm

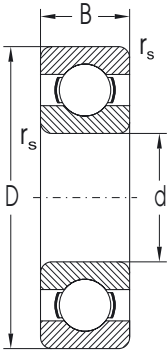

Dimensions				Basic Load Dynamic $C_r$	Rating Static $C_{or}$	Fatigue load limit $P_u$	Limiting Speed for Lubrication with		Bearing Designation
d	D	B	$r_s$ min				Grease	Oil	
mm				kN		kN	min <sup>-1</sup>		
95	145	16,0	1,00	42,300	41,500	1,722	4200	5000	<b>16019</b>
	145	24,0	1,50	60,700	54,100	2,245	4200	5000	<b>6019</b>
	170	32,0	2,10	108,000	81,000	3,199	3800	4500	<b>6219</b>
	200	45,0	3,00	152,444	117,366	4,393	3300	4000	<b>6319</b>
100	150	16,0	1,00	44,000	43,800	1,781	4200	5000	<b>16020</b>
	150	24,0	1,50	60,096	54,244	2,205	4200	5000	<b>6020</b>
	180	34,0	2,10	123,000	92,600	3,557	3500	4200	<b>6220</b>
	215	47,0	3,00	174,000	141,000	5,107	3200	3800	<b>6320</b>
105	160	26,0	2,00	72,200	65,600	2,590	4000	4700	<b>6021</b>
	190	36,0	2,10	132,927	104,833	3,924	3300	4000	<b>6221</b>
	225	49,0	3,00	185,000	153,000	5,414	3000	3500	<b>6321</b>
110	170	19,0	1,00	57,600	56,200	2,159	3800	4500	<b>16022</b>
	170	28,0	2,00	82,500	72,200	2,774	3800	4500	<b>6022</b>
	200	38,0	2,10	144,000	117,000	4,272	3200	3800	<b>6222</b>
	240	50,0	3,00	203,000	180,000	6,185	2600	3200	<b>6322</b>
120	180	19,0	1,00	61,000	63,100	2,342	3300	4000	<b>16024</b>
	180	28,0	2,00	85,000	79,400	2,947	3300	4000	<b>6024</b>
	215	40,0	2,10	144,000	117,000	4,109	3000	3500	<b>6224</b>
130	180	24,0	1,50	65,503	67,193	2,453	3200	3800	<b>61926</b>
	200	33,0	2,00	106,986	99,667	3,527	3200	3800	<b>6026</b>
	230	40,0	3,00	153,000	133,000	4,506	2800	3300	<b>6226</b>
140	210	33,0	2,00	110,000	108,000	3,711	3000	3500	<b>6028</b>
	250	42,0	3,00	166,000	150,000	4,883	2500	3000	<b>6228</b>
	225	35,0	2,10	126,000	126,000	4,183	2700	3200	<b>6030</b>
150	270	45,0	3,00	190,000	181,000	5,677	2200	2700	<b>6230</b>
	260	42,0	2,10	168,000	171,000	5,301	2200	2700	<b>6034</b>
900	1090	85,0	5,00	619,000	1530,000	22,047	380	450	<b>618/900MA</b>



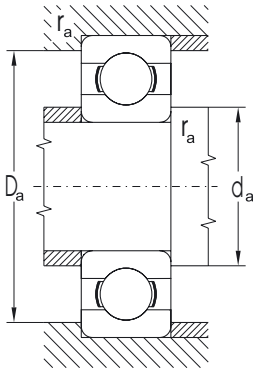

Abutment and Fillet Dimensions				Weight
d	d <sub>a</sub> min	D <sub>a</sub> max	r <sub>a</sub> max	~
mm				kg
95	100,0	140,0	1,0	0,8900
	102,0	137,0	1,5	1,2200
	107,0	158,0	2,0	2,6000
	109,0	186,0	2,5	5,7200
100	105,0	145,0	1,0	0,9100
	106,0	142,0	1,5	1,2700
	112,0	169,0	2,0	3,1300
	113,0	201,0	2,5	7,0700
105	113,0	151,0	2,0	1,5900
	117,0	178,0	2,0	3,7400
	119,0	211,0	2,5	8,0000
110	115,0	165,0	1,0	1,4600
	118,0	161,0	2,0	1,9500
	122,0	188,0	2,0	4,3700
	123,0	227,0	2,5	9,5800
120	125,0	175,0	1,0	1,8000
	128,0	171,0	2,0	2,1000
	132,0	203,0	2,0	5,1500
130	137,0	172,0	1,0	1,8600
	138,0	191,0	2,0	3,2600
	144,0	216,0	2,5	6,2000
140	148,0	200,0	2,0	3,3900
	154,0	236,0	2,5	7,5600
150	159,0	213,0	2,0	4,1600
	164,0	256,0	2,5	9,8500
170	179,0	248,0	2,0	6,9100
900	920,0	1070,0	4,0	165,0000

# Single Row Deep Groove Ball Bearings with Seals or Shields

d = 3 to 25 mm

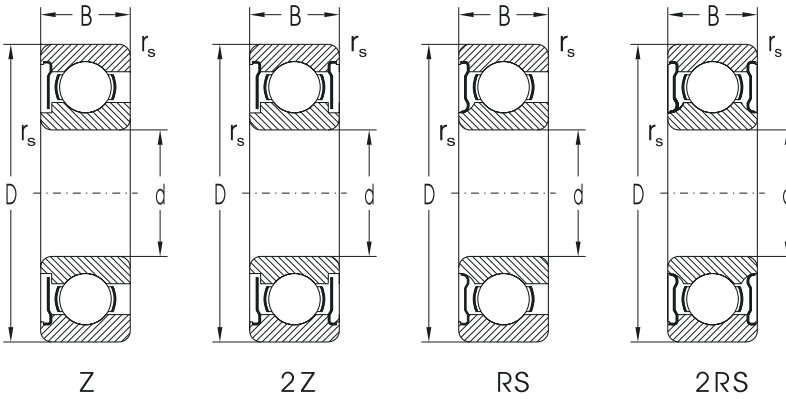

Dimensions				Basic Load Rating		Fatigue load limit $P_u$	Bearing Designation			
d	D	B	$r_s$ min	Dyn. $C_r$	Static $C_{or}$		Z, ZR	2Z, 2ZR	RS, RSR	2RS, 2RSR
mm				kN		kN				
3	10	4.0	0.15	0.645	0.229	0.01	<b>623ZR</b>	<b>623-2ZR</b>		
4	13	5.0	0.20	1.168	0.412	0.02	<b>624ZR</b>	<b>624-2ZR</b>		
	16	5.0	0.30	1.875	0.677	0.03	<b>634ZR</b>	<b>634-2ZR</b>		
5	16	5.0	0.30	1.875	0.677	0.03	<b>625ZR</b>	<b>625-2ZR</b>		
	19	6.0	0.30	2.838	1.078	0.05	<b>635ZR</b>	<b>635-2ZR</b>		
6	19	6.0	0.30	2.838	1.078	0.05	<b>626ZR</b>	<b>626-2ZR</b>		
	22	7.0	0.30	2.838	1.078	0.05	<b>607ZR</b>	<b>607-2ZR</b>		
7	22	7.0	0.30	3.282	1.356	0.06	<b>627ZR</b>	<b>627-2ZR</b>		
	24	7.0	0.30	3.282	1.356	0.06	<b>608ZR</b>	<b>608-2ZR</b>	<b>608RSR</b>	<b>608-2RSR</b>
8	24	7.0	0.30	3.668	1.640	0.07	<b>609ZR</b>	<b>609-2ZR</b>	<b>609RSR</b>	<b>609-2RSR</b>
	26	8.0	0.30	4.557	1.955	0.09	<b>629ZR</b>	<b>629-2ZR</b>	<b>629RSR</b>	<b>629-2RSR</b>
10	26	8.0	0.30	4.557	1.955	0.09	<b>6000ZR</b>	<b>6000-2ZR</b>	<b>6000RSR</b>	<b>6000-2RSR</b>
	30	9.0	0.60	6.047	2.510	0.11	<b>6200ZR</b>	<b>6200-2ZR</b>	<b>6200RSR</b>	<b>6200-2RSR</b>
	30	14.0	0.60	6.047	2.510	0.11	<b>62200ZR</b>	<b>62200-2ZR</b>	<b>62200RSR</b>	<b>62200-2RSR</b>
12	35	11.0	0.60	8.072	3.430	0.16	<b>6300ZR</b>	<b>6300-2ZR</b>	<b>6300RS</b>	<b>6300-2RS</b>
	28	8.0	0.30	5.094	2.360	0.11	<b>6001ZR</b>	<b>6001-2ZR</b>	<b>6001RSR</b>	<b>6001-2RSR</b>
	32	10.0	0.60	6.905	3.100	0.14	<b>6201ZR</b>	<b>6201-2ZR</b>	<b>6201RSR</b>	<b>6201-2RSR</b>
15	32	14.0	0.60	6.905	3.100	0.14	<b>62201ZR</b>	<b>62201-2ZR</b>	<b>62201RS</b>	<b>62201-2RS</b>
	37	12.0	1.00	9.759	4.235	0.19	<b>6301ZR</b>	<b>6301-2ZR</b>	<b>6301RS</b>	<b>6301-2RS</b>
	32	9.0	0.30	5.594	2.860	0.13	<b>6002ZR</b>	<b>6002-2ZR</b>	<b>6002RS</b>	<b>6002-2RS</b>
	35	11.0	0.60	7.718	3.745	0.17	<b>6202Z</b>	<b>6202-2Z</b>	<b>6202RS</b>	<b>6202-2RS</b>
17	35	14.0	0.60	7.718	3.745	0.17	<b>62202ZR</b>	<b>62202-2ZR</b>	<b>62202RS</b>	<b>62202-2RS</b>
	42	13.0	1.00	11.310	5.335	0.24	<b>6302ZR</b>	<b>6302-2ZR</b>	<b>6302RS</b>	<b>6302-2RS</b>
	35	10.0	0.30	5.999	3.265	0.15	<b>6003ZR</b>	<b>6003-2ZR</b>	<b>6003RS</b>	<b>6003-2RS</b>
	40	12.0	0.60	9.534	4.734	0.22	<b>6203Z</b>	<b>6203-2Z</b>	<b>6203RS</b>	<b>6203-2RS</b>
20	40	16.0	0.60	9.534	4.734	0.22	<b>62203ZR</b>	<b>62203-2ZR</b>	<b>62203RS</b>	<b>62203-2RS</b>
	47	14.0	1.00	13.565	6.563	0.30	<b>6303ZR</b>	<b>6303-2ZR</b>	<b>6303RS</b>	<b>6303-2RS</b>
	42	12.0	0.60	9.371	4.972	0.23	<b>6004ZR</b>	<b>6004-2ZR</b>	<b>6004RS</b>	<b>6004-2RS</b>
	47	14.0	1.00	12.774	6.553	0.30	<b>6204Z</b>	<b>6204-2Z</b>	<b>6204RS</b>	<b>6204-2RS</b>
25	47	18.0	1.00	12.774	6.553	0.30	<b>62204ZR</b>	<b>62204-2ZR</b>	<b>62204RS</b>	<b>62204-2RS</b>
	47	20.6	1.00	12.774	6.553	0.30	<b>63204Z</b>	<b>63204-2Z</b>	<b>63204RS</b>	<b>63204-2RS</b>
	52	15.0	1.10	15.866	7.811	0.36	<b>6304Z</b>	<b>6304-2Z</b>	<b>6304RS</b>	<b>6304-2RS</b>
	52	21.0	1.10	15.866	7.811	0.36	<b>62304Z</b>	<b>62304-2Z</b>	<b>62304RS</b>	<b>62304-2RS</b>
	47	12.0	0.60	10.070	5.806	0.26	<b>6005ZR</b>	<b>6005-2ZR</b>	<b>6005RS</b>	<b>6005-2RS</b>
	52	15.0	1.00	14.029	7.940	0.36	<b>6205Z</b>	<b>6205-2Z</b>	<b>6205RS</b>	<b>6205-2RS</b>
62	52	18.0	1.00	14.029	7.940	0.36	<b>62205ZR</b>	<b>62205-2ZR</b>	<b>62205RS</b>	<b>62205-2RS</b>
	62	17.0	1.10	21.123	10.806	0.49	<b>6305Z</b>	<b>6305-2Z</b>	<b>6305RS</b>	<b>6305-2RS</b>
	62	24.0	1.10	21.123	10.806	0.49	<b>62305Z</b>	<b>62305-2Z</b>	<b>62305RS</b>	<b>62305-2RS</b>

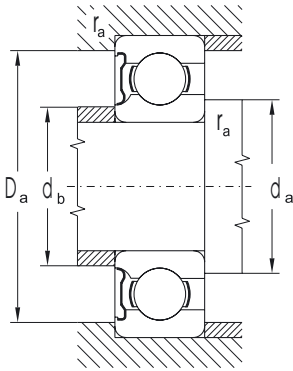

Limiting Speed for Lubrication with Grease		Abutment and Fillet Dimensions					Weight	
Z, 2Z	RS, 2RS	Oil Z	d min	d <sub>a</sub> max	d <sub>b</sub> max	D <sub>a</sub> max	r <sub>a</sub>	-
min <sup>-1</sup>			mm					kg
40000		50000	3	4.2	4.8	8.5	0.1	0.0020
38000		45000	4	5.5	5.8	11.2	0.2	0.0040
35000		42000		6.2	6.5	13.4	0.3	0.0050
35000		42000	5	7.0	7.0	14.0	0.3	0.0060
35000		42000		7.2	7.5	15.8	0.3	0.0090
35000		42000	6	8.2	8.3	17.0	0.3	0.0100
35000		42000	7	9.0	9.0	17.0	0.3	0.0100
35000		42000		9.2	9.8	19.5	0.3	0.0120
35000	24000	42000	8	10.0	10.0	20.0	0.3	0.0150
35000	24000	42000	9	11.0	12.0	22.0	0.3	0.0180
35000	24000	42000		12.0	12.5	22.5	0.3	0.0200
28000	19000	33000	10	12.0	12.5	24.0	0.3	0.0200
25000	17000	30000		14.0	14.4	26.0	0.6	0.0320
25000	17000	30000		14.0	14.4	26.0	0.6	0.0400
22000	15000	27000		14.0	15.0	31.0	0.6	0.0530
25000	17000	30000	12	14.0	14.5	26.0	0.3	0.0220
22000	15000	27000		16.0	16.5	28.0	0.6	0.0370
22000	15000	27000		16.0	16.5	28.0	0.6	0.0450
20000	13000	24000		17.0	17.0	32.0	1.0	0.0600
21000	14000	25000	15	17.0	18.0	30.0	0.3	0.0310
20000	13000	24000		19.0	19.5	31.0	0.6	0.0450
20000	13000	24000		19.0	19.5	31.0	0.6	0.0540
18000	12000	21000		20.0	20.5	36.0	1.0	0.0820
20000	13000	24000	17	19.0	20.0	33.0	0.3	0.0400
18000	12000	21000		21.0	21.4	36.0	0.6	0.0650
18000	12000	21000		21.0	21.4	36.0	0.6	0.0830
16000	10600	19000		23.0	23.0	41.0	1.0	0.1160
17000	11000	20000	20	24.0	24.5	38.0	0.3	0.0700
15000	10000	18000		25.0	25.5	42.0	0.6	0.1070
15000	10000	18000		25.0	25.5	42.0	0.6	0.1300
15000	10000	18000		25.0	25.5	42.0	0.6	0.1540
14000	9400	17000		26.0	26.6	45.0	1.0	0.1440
14000	9400	17000		26.0	26.6	45.0	1.0	0.2000
14000	9400	17000	25	28.0	29.0	43.0	0.6	0.0810
12600	8400	15000		30.0	30.5	47.0	1.0	0.1280
12600	8400	15000		30.0	30.5	47.0	1.0	0.1500
11000	7500	13000		31.0	33.0	55.0	1.0	0.2320
11000	7500	13000		31.0	33.0	55.0	1.0	0.3200

# Single Row Deep Groove Ball Bearings with Seals or Shields

d = 30 to 100 mm

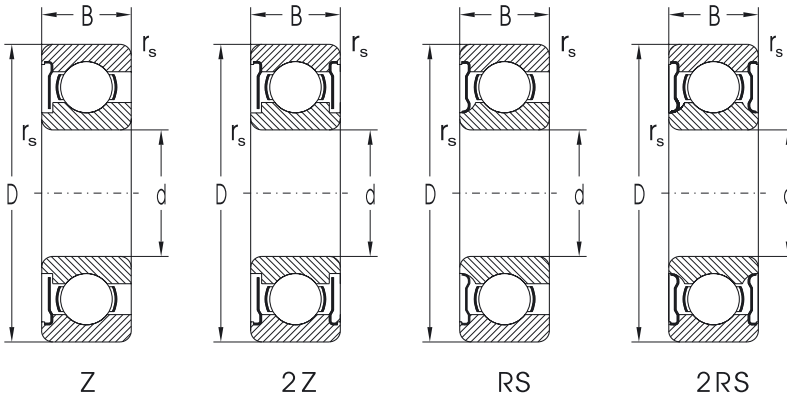

Dimensions				Basic Load Rating		Fatigue load limit $P_u$	Bearing Designation			
d	D	B	$r_s$ min	Dyn. $C_r$	Static $C_{or}$		Z, ZR	2Z, 2ZR	RS, RSR	2RS, 2RSR
mm				kN		kN				
30	55	13	1.00	13.243	8.253	0.38	6006Z	6006-2Z	6006RS	6006-2RS
	62	16	1.00	19.443	11.186	0.51	6206Z	6206-2Z	6206RS	6206-2RS
	62	20	1.00	19.443	11.186	0.51	62206Z	62206-2Z	62206RS	62206-2RS
35	72	19	1.10	29.701	15.678	0.71	6306Z	6306-2Z	6306RS	6306-2RS
	62	14	1.00	15.956	10.328	0.47	6007Z	6007-2Z	6007RS	6007-2RS
	72	17	1.10	25.663	15.227	0.69	6207Z	6207-2Z	6207RS	6207-2RS
40	80	21	1.50	33.367	19.230	0.87	6307Z	6307-2Z	6307RS	6307-2RS
	68	15	1.00	16.824	11.493	0.52	6008Z	6008-2Z	6008RS	6008-2RS
	80	18	1.10	32.633	19.887	0.90	6208Z	6208-2Z	6208RS	6208-2RS
45	90	23	1.50	40.760	24.017	1.09	6308Z	6308-2Z	6308RS	6308-2RS
	75	16	1.00	21.100	15.300	0.70	6009Z	6009-2Z	6009RS	6009-2RS
	85	19	1.10	32.687	20.323	0.92	6209Z	6209-2Z	6209RS	6209-2RS
50	100	25	1.50	52.804	31.715	1.44	6309Z	6309-2Z	6309RS	6309-2RS
	80	16	1.00	21.720	16.650	0.76	6010Z	6010-2Z	6010RS	6010-2RS
	90	20	1.10	35.066	23.266	1.06	6210Z	6210-2Z	6210RS	6210-2RS
55	110	27	2.00	61.754	37.745	1.72	6310Z	6310-2Z	6310RS	6310-2RS
	90	18	1.10	28.216	21.318	0.97	6011Z	6011-2Z	6011RS	6011-2RS
	100	21	1.50	43.350	29.397	1.34	6211Z	6211-2Z	6211RS	6211-2RS
60	120	29	2.00	71.000	44.700	2.03	6311Z	6311-2Z	6311RS	6311-2RS
	95	18	1.10	29.343	23.256	1.06	6012Z	6012-2Z	6012RS	6012-2RS
	110	22	1.50	52.486	35.786	1.63	6212Z	6212-2Z	6212RS	6212-2RS
65	130	31	2.10	81.500	52.100	2.37	6312Z	6312-2Z	6312RS	6312-2RS
	100	18	1.10	30.500	25.100	1.14	6013Z	6013-2Z	6013RS	6013-2RS
	120	23	1.50	57.210	40.011	1.82	6213Z	6213-2Z	6213RS	6213-2RS
70	140	33	2.10	92.600	59.600	2.68	6313Z	6313-2Z	6313RS	6313-2RS
	110	20	1.10	37.960	30.959	1.41	6014Z	6014-2Z	6014RS	6014-2RS
	125	24	1.50	62.000	43.800	1.99	6214Z	6214-2Z	6214RS	6214-2RS
75	150	35	2.10	104.000	68.100	2.95	6314Z	6314-2Z	6314RS	6314-2RS
	115	20	1.10	39.747	33.170	1.51	6015Z	6015-2Z	6015RS	6015-2RS
	130	25	1.50	66.179	49.311	2.21	6215Z	6215-2Z	6215RS	6215-2RS
80	160	37	2.10	114.000	76.400	3.20	6315Z	6315-2Z	6315RS	6315-2RS
	125	22	1.10	47.500	39.800	1.79	6016Z	6016-2Z	6016RS	6016-2RS
	140	26	2.00	72.200	53.100	2.30	6216Z	6216-2Z	6216RS	6216-2RS
85	170	39	2.10	122.850	86.226	3.51	6316Z	6316-2Z		
	130	22	1.10	49.794	42.609	1.87	6017Z	6017-2Z		
	150	28	2.00	83.299	63.675	2.67	6217Z	6217-2Z	6217RS	6217-2RS
90	180	41	3.00	132.507	96.069	3.79	6317Z	6317-2Z		
	160	30	2.00	96.200	70.800	2.88	6218Z	6218-2Z		
	190	43	3.00	143.000	104.000	4.00	6318Z	6318-2Z		
100	150	24	1.50	60.000	54.000	2.20	6020Z	6020-2Z		

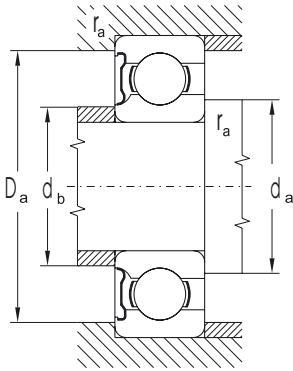

Limiting Speed for Lubrication with Grease			Abutment and Fillet Dimensions					Weight
Z, 2Z	RS, 2RS	Oil Z	d min	d <sub>a</sub> max	d <sub>b</sub> max	D <sub>a</sub> max	r <sub>a</sub>	-
min <sup>-1</sup>			mm					kg
12000	7900	14000	30	34.0	35.0	50.0	1.0	0.1190
11000	7500	13000		35.0	36.7	57.0	1.0	0.2010
11000	7500	13000		35.0	36.7	57.0	1.0	0.2400
10000	6700	12000		36.0	38.9	65.0	1.0	0.3500
10600	7100	12600	35	39.5	39.5	57.0	1.0	0.1590
9400	6300	11000		42.0	42.0	65.0	1.0	0.2900
8400	5600	10000		42.0	44.0	71.0	1.5	0.4600
9400	6300	11000	40	44.0	46.0	63.0	1.0	0.1950
8400	5600	10000		47.0	48.0	73.0	1.0	0.3670
7900	5300	9400		47.0	50.6	81.0	1.5	0.6350
8400	5600	10000	45	49.0	51.5	70.0	1.0	0.2490
7900	5300	9400		52.0	52.5	78.0	1.0	0.4100
7100	4700	8400		52.0	56.0	91.0	1.5	0.8330
7900	5300	9400	50	54.0	56.5	75.0	1.0	0.2640
7100	4700	8400		57.0	58.0	83.0	1.0	0.4640
6300	4200	7500		60.0	61.8	100.0	2.0	1.0800
7100	4700	8400	55	60.0	62.5	84.0	1.0	0.3900
6700	4500	7900		62.0	65.0	91.0	1.5	0.6100
5600	3800	6700		65.0	67.0	110.0	2.0	1.3800
6700	4500	7900	60	65.0	68.0	88.0	1.0	0.4200
6000	4000	7100		67.0	70.2	101.0	1.5	0.7870
5300	3500	6300		72.0	75.0	118.0	2.0	1.7200
6300	4200	7500	65	70.0	73.0	93.0	1.0	0.4400
5300	3500	6300		72.0	77.0	111.0	1.5	0.9950
5000	3300	6000		76.0	78.0	128.0	2.0	2.1000
5600	3800	6700	70	75.0	78.0	103.0	1.0	0.6180
5300	3500	6300		77.0	82.0	116.0	1.5	1.0900
4700	3200	5600		81.0	85.0	138.0	2.0	2.5300
5300	3500	6300	75	80.0	83.0	108.0	1.0	0.6400
5000	3300	6000		82.0	85.0	121.0	1.5	1.1900
4200	2800	5000		86.0	93.0	148.0	2.0	3.0300
5000	3300	6000	80	85.0	90.0	118.0	1.0	0.8600
4700	3200	5600		90.0	92.0	130.0	2.0	1.4100
4000		4700		91.0	99.0	158.0	2.0	3.6200
4700		5600	85	90.0	95.0	123.0	1.0	0.8900
4200	2800	5000		95.0	99.0	140.0	2.0	1.7900
3800		4500		98.0	103.0	166.0	2.5	4.2600
4000		4700	90	100.0	105.0	150.0	2.0	2.1600
3400		4200		103.0	108.0	176.0	2.5	5.1500
4200		5000	100	106.0	110.0	142.0	1.5	1.2700

# Single Row Deep Groove Ball Bearings with Snap Ring Groove on Outer Ring

d = 12 to 50 mm

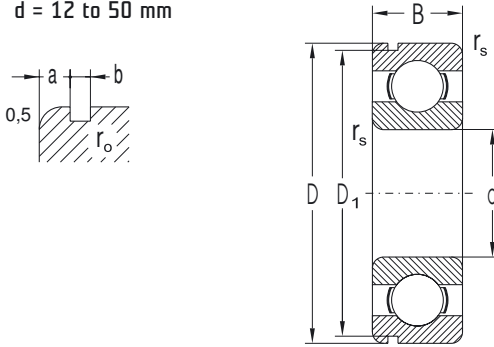

Dimensions								Basic Load Rating		Fatigue load limit $P_u$	Limiting Speed for Lubrication with	
d	D	B	$r_s$ min	$D_1$ max	a max	b min	$r_o$ max	Dynamic $C_1$	Static $C_{or}$		Grease	Oil
mm								kN		kN	min <sup>-1</sup>	
12	32	10	0.66	30.15	2.06	1.35	0.4	6.905	3.100	0.141	22000	27000
	32	14	0.66	30.15	2.06	1.35	0.4	6.905	3.100	0.141	22000	27000
15	35	11	0.60	33.17	2.06	1.35	0.4	7.718	3.745	0.170	20000	24000
	35	14	0.60	33.17	2.06	1.35	0.4	7.718	3.745	0.170	20000	24000
17	40	12	0.60	38.10	2.06	1.35	0.4	9.534	4.734	0.215	18000	21000
	40	16	0.60	38.10	2.06	1.35	0.4	9.534	4.734	0.215	18000	21000
	47	14	1.00	44.60	2.46	1.35	0.4	13.565	6.563	0.298	16000	19000
20	42	12	0.60	39.75	2.06	1.35	0.4	9.371	4.972	0.226	17000	20000
	47	14	1.00	44.60	2.46	1.35	0.4	12.774	6.553	0.298	15000	18000
	52	15	1.10	49.73	2.46	1.35	0.4	15.866	7.811	0.355	14000	17000
	52	21	1.10	49.73	2.46	1.35	0.4	15.866	7.811	0.355	14000	17000
25	47	12	0.60	44.60	2.06	1.35	0.4	10.070	5.806	0.264	14000	17000
	52	15	1.00	49.73	2.46	1.35	0.4	14.029	7.940	0.361	12600	15000
	52	18	1.00	49.73	2.46	1.35	0.4	14.029	7.940	0.361	12600	15000
	62	17	1.10	59.61	3.28	1.90	0.6	21.123	10.806	0.491	11000	13000
	62	24	1.10	59.61	3.28	1.90	0.6	21.123	10.806	0.491	11000	13000
	80	21	1.50	76.81	3.28	1.90	0.6	36.000	19.200	0.873	9400	11000
30	55	13	1.00	52.60	2.08	1.90	0.4	13.243	8.253	0.375	12000	14000
	62	16	2.00	59.61	3.28	1.90	0.6	19.443	11.186	0.508	11000	13000
	62	20	2.00	59.61	3.28	1.90	0.6	19.443	11.186	0.508	11000	13000
	72	19	1.10	68.81	3.28	1.90	0.6	29.701	15.678	0.713	10000	12000
	90	23	1.50	86.79	3.28	2.70	0.6	43.000	23.700	1.077	8400	10000
35	62	14	1.00	59.61	2.06	1.90	0.6	15.956	10.328	0.469	10600	12600
	72	17	1.10	68.81	3.28	1.90	0.6	25.663	15.277	0.694	9400	11000
	80	21	1.50	78.81	3.28	1.90	0.6	33.367	19.230	0.874	8400	10000
	100	25	1.50	96.80	3.28	2.70	0.6	55.200	31.000	1.409	7500	8900
40	68	15	1.00	64.82	2.49	1.90	0.6	16.824	11.493	0.522	9400	11000
	80	18	1.10	76.81	3.28	1.90	0.6	32.633	19.887	0.904	8400	10000
	90	23	1.50	86.79	3.28	2.70	0.6	40.760	24.017	1.092	7900	9400
	110	27	2.00	106.81	3.28	2.70	0.6	63.100	36.200	1.645	6700	7900
45	75	16	1.00	71.83	2.49	1.90	0.6	21.100	15.300	0.695	8400	10000
	85	19	1.10	81.81	3.28	1.90	0.6	32.687	20.325	0.924	7900	9400
	100	25	1.50	96.80	3.28	2.70	0.6	52.804	31.715	1.442	7100	8400
	120	29	2.00	115.21	4.06	3.10	0.6	76.500	44.700	2.032	6000	7100
50	80	16	1.00	76.81	2.49	1.90	0.6	21.720	16.650	0.757	7900	9400
	90	20	1.10	86.79	3.28	2.70	0.6	35.066	23.226	1.056	7100	8400
	110	27	2.00	106.81	3.28	2.70	0.6	61.900	37.600	1.709	6300	7500

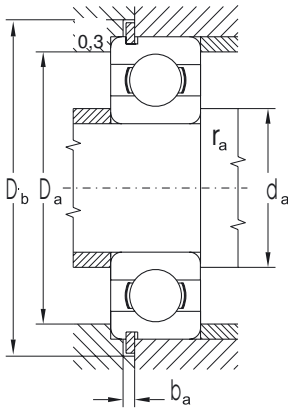

Bearing Designation	Abutment and Fillet Dimensions						Weight	Respective snap ring
	$d_{min}$	$d_a$	$D_a$	$D_b$	$b_a$	$r_a$		
	mm						kg	
<b>6201N</b>	12	16.0	28.0	39.0	1.4	0.6	0.04	R32
<b>62201N</b>		16.0	28.0	39.0	1.4	0.6	0.05	R32
<b>6202N</b>	15	19.0	31.0	41.0	1.4	0.6	0.03	R35
<b>62202N</b>		19.0	31.0	41.0	1.4	0.6	0.05	R35
<b>6203N</b>	17	21.0	36.0	46.0	1.5	0.6	0.07	R40
<b>62203N</b>		21.0	36.0	46.0	1.5	0.6	0.08	R40
<b>6303N</b>		23.0	41.0	54.0	1.5	1.0	0.12	R47
<b>6004N</b>	20	24.0	38.0	47.5	1.5	0.6	0.07	R42
<b>6204N</b>		25.0	42.0	54.0	1.5	1.0	0.11	R47
<b>6304N</b>		26.0	45.0	59.0	1.5	1.0	0.15	R52
<b>62304N</b>		26.0	45.0	59.0	1.5	1.0	0.20	R52
<b>6005N</b>	25	28.0	43.0	54.0	1.5	0.6	0.08	R47
<b>6205N</b>		30.0	47.0	59.0	1.5	1.0	0.13	R52
<b>62205N</b>		30.0	47.0	59.0	1.5	1.0	0.15	R52
<b>6305N</b>		31.0	55.0	69.0	2.2	1.0	0.23	R62
<b>62305N</b>		31.0	55.0	69.0	2.2	1.0	0.32	R62
<b>6405N</b>		34.0	70.0	88.0	2.2	1.5	0.53	R80
<b>6006N</b>	30	34.0	50.0	62.0	1.5	1.0	0.12	R55
<b>6206N</b>		35.0	57.0	69.0	2.2	1.0	0.20	R62
<b>62206N</b>		35.0	57.0	69.0	2.2	1.0	0.24	R62
<b>6306N</b>		36.0	65.0	80.0	2.2	1.0	0.33	R72
<b>6406N</b>		39.0	80.0	98.0	3.0	1.5	0.73	R90
<b>6007N</b>	35	39.5	57.0	69.0	2.2	1.0	0.15	R62
<b>6207N</b>		42.0	65.0	80.0	2.2	1.0	0.28	R72
<b>6307N</b>		42.0	71.0	88.0	2.2	1.5	0.45	R80
<b>6407N</b>		44.0	90.0	108.0	3.0	1.5	0.95	R100
<b>6008N</b>	40	44.0	63.0	76.0	2.2	1.0	0.19	R68
<b>6208N</b>		47.0	73.0	88.0	2.2	1.0	0.35	R80
<b>6308N</b>		47.0	81.0	98.0	3.0	1.5	0.63	R90
<b>6408N</b>		50.0	97.0	118.0	3.0	3.0	1.23	R110
<b>6009N</b>	45	49.0	70.0	83.0	2.2	1.0	0.24	R75
<b>6209N</b>		52.0	78.0	93.0	2.2	1.0	0.40	R85
<b>6309N</b>		52.0	91.0	108.0	3.0	1.5	0.83	R100
<b>6409N</b>		55.0	107.0	131.0	3.5	2.0	1.54	R120
<b>6010N</b>	50	54.0	75.0	88.0	2.2	1.0	0.26	R80
<b>6210N</b>		57.0	83.0	98.0	3.0	1.0	0.46	R90
<b>6310N</b>		60.0	100.0	118.0	3.0	2.0	1.06	R110

# Single Row Deep Groove Ball Bearings with Snap Ring Groove on Outer Ring

d = 55 to 120 mm

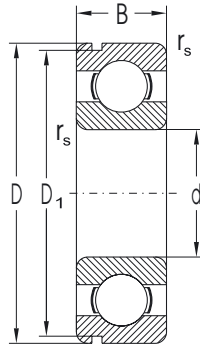
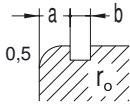

Dimensions								Basic Load Rating Dynamic $C_1$	Rating Static $C_{or}$	Fatigue load limit $P_u$	Limiting Speed for Lubrication with	
d	D	B	$r_{s \min}$	$D_{1 \max}$	a max	b min	$r_{o \max}$				Grease	Oil
mm								kN		kN	$\text{min}^{-1}$	
55	90	18	1.10	86.79	2.87	2.70	0.6	28.200	21.318	0.969	7100	8400
	100	21	1.50	96.80	3.28	2.70	0.6	43.350	29.397	1.336	6700	7900
	120	29	2.00	115.21	4.06	3.10	0.6	71.000	44.700	2.032	5600	6700
	140	33	2.10	135.23	4.90	3.10	0.6	100.000	61.900	2.814	5300	6300
60	95	18	1.10	91.82	2.87	2.70	0.6	29.343	23.256	1.057	6700	7900
	110	22	1.50	106.81	3.82	2.70	0.6	52.486	35.786	1.627	6000	7100
	130	31	2.10	125.22	4.06	3.10	0.6	81.500	52.100	2.368	5300	6300
	150	35	2.10	145.24	4.90	3.10	0.6	110.000	69.400	3.079	4700	5600
65	100	18	1.10	96.80	2.87	2.70	0.6	30.500	25.100	1.141	6300	7500
	120	23	1.50	115.21	4.06	3.10	0.6	57.210	40.011	1.819	5300	6300
	140	33	2.10	135.23	4.90	3.10	0.6	92.600	59.600	2.676	5000	6000
	160	37	2.10	155.22	4.90	3.10	0.6	117.950	78.329	3.357	4500	5300
70	110	20	1.10	106.81	2.87	2.70	0.6	37.960	30.959	1.407	5600	6700
	125	24	1.50	120.22	4.06	3.10	0.6	62.000	43.800	1.991	5300	6300
	150	35	2.10	145.24	4.90	3.10	0.6	104.000	68.100	2.951	4700	5600
	180	42	3.00	173.66	5.69	3.50	0.6	114.000	104.000	4.228	4000	4700
75	115	20	1.10	111.81	2.87	2.70	0.6	39.747	33.170	1.508	5300	6300
	130	25	1.50	125.22	4.06	3.10	0.6	66.170	49.311	2.214	5000	6000
	160	37	2.10	155.22	4.90	3.10	0.6	114.000	76.400	3.204	4200	5000
	190	45	3.00	183.64	5.69	3.50	0.6	152.529	112.922	4.459	3800	4500
80	125	22	1.10	120.22	2.87	3.10	0.6	47.500	39.800	1.787	5000	6000
	140	26	2.00	135.23	4.90	3.10	0.6	72.200	53.100	2.301	4700	5600
	170	39	2.10	163.65	5.69	3.50	0.6	122.850	86.226	3.506	4000	4700
	200	48	3.00	193.65	5.69	3.50	0.6	163.587	124.984	4.801	3500	4200
85	130	22	1.10	125.22	2.87	3.10	0.6	49.794	42.609	1.868	4700	5600
	150	28	2.00	145.24	4.90	3.10	0.6	83.299	63.675	2.670	4200	5000
	180	41	3.00	173.66	5.69	3.50	0.6	132.507	96.069	3.794	3800	4500
90	140	24	1.50	135.23	3.71	3.10	0.6	58.400	49.200	2.085	4500	5300
	160	30	2.00	155.22	4.90	3.10	0.6	96.200	70.800	2.878	4000	4700
95	200	45	3.00	193.65	5.69	3.50	0.6	152.444	117.366	4.393	3300	4000
	100	150	24	1.50	145.24	3.71	3.10	0.6	60.096	54.244	2.205	4200
105	190	36	2.10	183.64	5.96	3.50	0.6	132.297	104.833	3.924	3300	4000
120	180	28	2.00	173.66	3.71	3.50	0.6	85.000	79.400	2.947	3300	4000



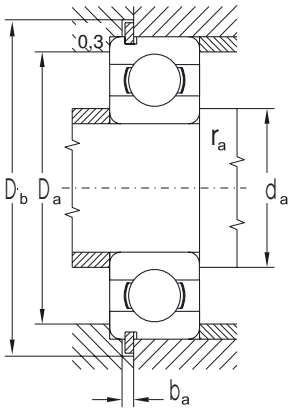

Bearing Designation	Abutment and Fillet Dimensions						Weight	Respective snap ring
	$d_{\min}$	$d_a$	$D_a$	$D_b$	$b_a$	$r_a$		
	mm						kg	
<b>6011N</b>	55	60.0	84.0	98.0	3.0	1.0	0.38	R90
<b>6211N</b>		62.0	91.0	108.0	3.0	1.5	0.60	R100
<b>6311N</b>		65.0	110.0	131.0	3.5	2.0	1.38	R120
<b>6411N</b>		68.0	126.0	151.0	3.5	2.0	2.29	R140
<b>6012N</b>	60	65.0	88.0	103.0	3.0	1.0	0.41	R95
<b>6212N</b>		67.0	101.0	110.0	3.0	1.5	0.77	R110
<b>6312N</b>		72.0	118.0	141.0	3.5	2.0	1.72	R130
<b>6412N</b>		73.0	136.0	162.0	3.5	2.0	2.76	R150
<b>6013N</b>	65	70.0	93.0	108.0	3.0	1.0	0.44	R100
<b>6213N</b>		72.0	111.0	131.0	3.5	1.5	1.00	R120
<b>6313N</b>		76.0	128.0	148.0	3.5	2.0	2.10	R140
<b>6413N</b>		78.0	146.0	172.0	3.5	2.0	3.28	R160
<b>6014N</b>	70	75.0	103.0	118.0	3.0	1.0	0.60	R110
<b>6214N</b>		77.0	116.0	136.0	3.5	1.5	1.07	R125
<b>6314N</b>		81.0	138.0	162.0	3.5	2.0	2.54	R150
<b>6414N</b>		85.0	164.0	195.0	4.5	2.5	4.85	R180
<b>6015N</b>	75	80.0	108.0	123.0	3.0	1.0	0.64	R115
<b>6215N</b>		82.0	121.0	141.0	3.5	1.5	1.18	R130
<b>6315N</b>		86.0	148.0	172.0	3.5	2.0	3.06	R160
<b>6415N</b>		90.0	174.0	205.0	4.5	2.5	5.74	R190
<b>6016N</b>	80	85.0	118.0	136.0	3.5	1.0	0.85	R125
<b>6216N</b>		90.0	130.0	151.0	3.5	2.0	1.40	R140
<b>6316N</b>		91.0	158.0	185.0	3.5	2.0	3.63	R170
<b>6416N</b>		95.0	184.0	215.0	4.5	2.5	6.72	R200
<b>6017N</b>	85	91.5	123.5	141.0	3.5	1.0	0.89	R130
<b>6217N</b>		95.0	140.0	162.0	3.5	2.0	1.80	R150
<b>6317N</b>		98.0	166.0	195.0	4.5	2.5	4.20	R180
<b>6018N</b>	90	96.0	132.0	151.0	3.5	1.5	1.17	R140
<b>6218N</b>		100.0	150.0	172.0	3.5	2.0	2.16	R160
<b>6319N</b>	95	109.0	186.0	215.0	4.5	2.5	5.72	R200
<b>6020N</b>	100	106.0	142.0	162.0	3.5	1.5	1.27	R150
<b>6221N</b>	105	117.0	178.0	205.0	4.5	2.0	3.74	R190
<b>6024N</b>	120	188.0	171.0	195.0	4.5	2.0	2.10	R180

# Separable Single Row Ball Bearings

d = 10 to 20 mm

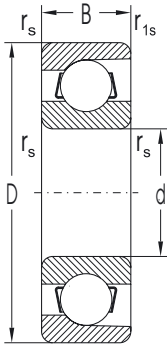

Dimensions					Basic Load Rating Dynamic $C_r$	Rating Static $C_{or}$	Fatigue load limit $P_u$	Limiting Speed for Lubrication with		Bearing Designation
d	D	B	$r_s$ min	$r_{1s}$ min				Grease	Oil	
mm					kN		kN	min <sup>-1</sup>		
10	28	8	0.3	0.15	6.45	2.91	0.13	25000	31000	<b>E10Y</b>
12	32	7	0.3	0.15	6.36	3.37	0.15	22000	28000	<b>E12TNG</b>
15	35	8	0.3	0.15	8.40	4.58	0.21	20000	24000	<b>E15</b>
	35	8	0.3	0.15	8.40	4.58	0.21	20000	24000	<b>E15Y</b>
17	44	11	0.6	0.30	10.71	6.08	0.28	16000	19000	<b>E17</b>
	44	11	0.6	0.30	14.72	8.07	0.37	14000	17000	<b>B017</b>
20	47	12	1.0	0.60	15.88	9.15	0.42	14000	17000	<b>E20</b>



# Single Row Angular Contact Ball Bearings

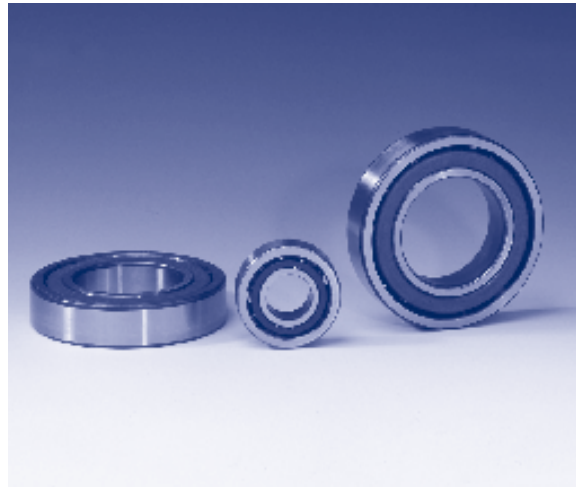

Raceways of single row angular contact ball bearings are designed in such a way that the connecting line of their contact points with the balls creates with the perpendicular line to the bearing axis an acute angle, so called contact angle and are non-separable. Bearings in B and BE design have contact angle  $\alpha = 40^\circ$ . This design allows the bearings to accommodate radial loads, acting simultaneously with a relative great axial load in one direction. For axial load accommodation in both directions, the bearings are arranged in pairs against each other.

In the production programme there are bearings in AA design where the contact angle is  $\alpha = 26^\circ$ , in A design the contact angle is  $\alpha = 25^\circ$ .

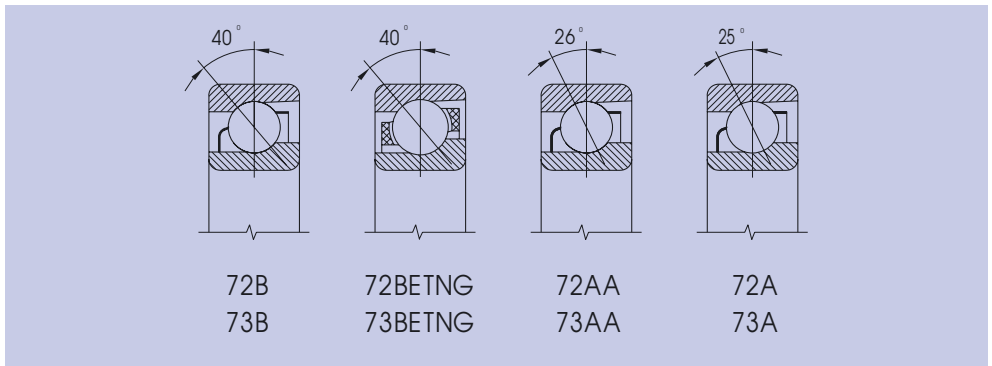

Single row angular contact bearings - type A70 and A72 or B70 and B72 are determined for high rotational speeds. They differ from standard bearings of this type by internal design, bearing ring design, contact angle

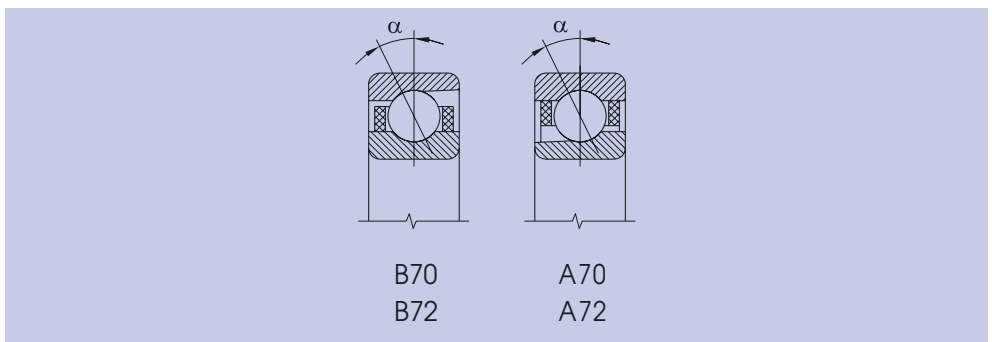



size, cage design and high tolerance class. Bearings are non-separable.

Bearings with CB designation have contact angle  $\alpha = 10^\circ$ . They are usually produced in tolerance class P4, P4A and are determined for very precision arrangements with high rotational speed, e.g. grinding electric spindles and appliances.

Bearings with designation CA have contact angle  $\alpha = 12^\circ$ .

Bearings in C design have contact angle  $\alpha = 15^\circ$ , they are produced in tolerance classes P5, P5A and P4, P4A and are predominately used for machine tool spindle arrangements and similar devices.

Bearings in AA design are produced in tolerance classes P5 and P4 and are determined for machine tool spindle arrangement and similar devices with relatively higher axial load.

## Boundary Dimensions

Boundary dimensions comply with the standard ISO 15 and are shown in the dimension tables of this publication.

## Designation

Bearing designation in standard design is a part of the data in the dimension tables. Difference from standard design is designated by additional symbols (section 2.2).

## Cage

Bearings - type 72 and 73 in B and AA design have a sheet cage which is not indicated. Bearings - type 72 and 73 in BE design have a solid cage made of polyamide strengthened by glass fibres (TNG).

Bearings - type A70 and A72 determined for high rotational speeds have a solid cage made of textite, centered on outer ring (TA) and bearings - type B70 and B72 have a solid textite cage centered on inner ring (TB), besides the bearing B7014AA which has a solid brass cage centered on inner ring (MB).

## Tolerance

Single row angular contact ball bearings - Type 72 and 73 are commonly produced in normal tolerance class P0 which is not indicated. For more demanding arrangements bearings in tolerance class P6 are delivered.

Bearings - type A70, A72, B70 and B72 in CA, C and A design are produced and delivered in tolerance classes P5, P5A and P4, P4A.

Bearings - type A72 and B72 in CB design are produced only in tolerance class P4, P4A. Deliveries of bearings in higher tolerance classes should be discussed with the supplier in advance.

Limiting deviation values of dimension and running accuracy comply with the standards ISO 199 and ISO 492 and are shown in tables 10 to 13.

## Internal Clearance

Usual utilization of single row ball bearings is in pairs. Suitable operating clearance or preload is adjusted at mounting and depends on arrangement design and operating conditions.

## Bearing Arrangement in Pairs

Bearings in A70, A72, B70 and B72 design are determined for high rotational speeds and are delivered in pairs.

### Pair in "O" Arrangement (back to back)

This pair is significant by its high rigidity against tilting and carries axial forces in both directions always only by one bearing. It is used for accommodation of tilting moments.

Arrangement scheme - see section 2.2 .

### Pair in "X" Arrangement (face to face)

From the point of view of carrying axial forces this pair has the same properties as pair "O", but it has smaller rigidity for accommodating the tilting moment.

Arrangement scheme - see section 2.2 .

## Pair in "T" Arrangement (tandem)

This pair is significant by its rigidity against tilting, but it is capable of carrying the axial load in one direction only.

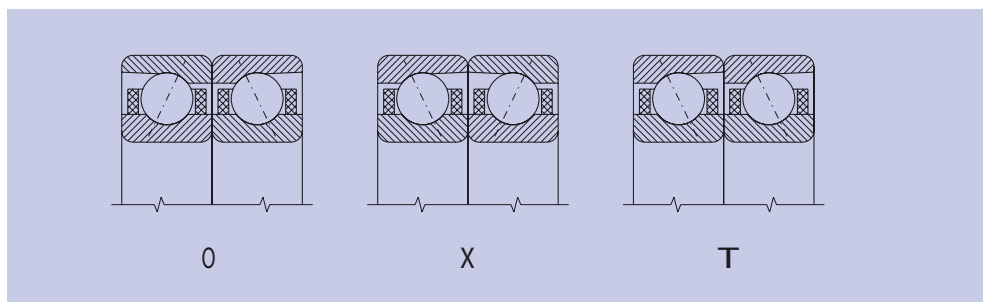

Arrangement scheme - see section 2.2.

The matched bearing pair is delivered in a common package to prevent interchange. Position of the greatest runout is marked by a line on ring faces. Mutual ring position is designated by converging lines in "V" shape on the outer cylindrical surface of the matched pair. Bearings are mounted in the arrangement so that the lines indicating the place of the greatest runout can lie on a line parallel to the shaft axis.

Matched pairs "X" and "O" are delivered with small (L), medium (M) and heavy (S) preload. Designation example of such a pair - B7204CBTB P40L or A7201AATA P5XM.

Axial preload is determined from relation :

$$F_p = k C_r \cdot 10^{-2} \quad [\text{kN}]$$

$F_p$  - axial preload [kN]

$C_r$  - radial basic dynamic load [kN]

$k$  - axial preload factor according to the table

Axial Preload		Factor k			
Magnitude	Designation	Contact Angle $\alpha$			
		10°	15°	26°	
		Bearing Design			
		CB	CA	C	AA
Small	L	0.4	0.5	0.7	1.2
Medium	M	1.4	1.6	2.0	3.5
Heavy	S	2.8	3.2	4.0	7.0

Radial basic dynamic load rating of matched pair  $C_{rs}$  is :

$$C_{rs} = 1.62 \cdot C_r \quad [\text{kN}]$$

Radial basic static load rating of matched pair  $C_{ors}$  is:

$$C_{ors} = 2 \cdot C_{or} \quad [\text{kN}]$$

Values  $C_r$  and  $C_{or}$  are shown in the dimension tables of this publication.

Limiting rotational speed for matched pair is smaller than for individual bearing (shown in dimension tables) :

- pair with small preload (L) of 20%

- pair with medium preload (M) of 35%
- pair with heavy preload (S) of 60%

## Bearings Matching in Sets of Three and Four Bearings

For special accurate arrangement requiring high accuracy, rigidity, load rating and high rotational speed bearings - type A70, A72, B70 and B72 matched in sets of three or four bearings are delivered. Scheme of this arrangement - see section 2.2 .

## Universal Bearing Matching

Single row angular contact ball bearings B70. .CTA in universal design (U) are determined for matching in pairs, in "X", "O" or "T" arrangements, or for matching in sets of three or four bearings. They are manufactured with a light preload (UL) by "X" and "O" matching.

Bearing deliveries in universal design should be discussed with the supplier in advance.

## Misalignment

Single row angular contact ball bearings mounted in pairs are sensitive to mutual bearing ring misalignment.

Tolerance of the arrangement surfaces for bearings in tolerance class P5 and P4 are :

Tolerance Class	Shaft Inner Ring Load		Housing Bore Outer Ring Load		Circumferential
	Circumferential	Point	Locating Bearing	Non-Locating Bearing	
P5	js5	h5	JS5	H5	M5
P4	js4	h4	JS5	H5	M5

## Radial Equivalent Dynamic Load

Bearings with contact angle  $\alpha = 40^\circ$ , B and BE design :

Single bearings :

$$P_r = F_r \quad \text{for } F_a/F_r \leq 1.14 \quad [\text{kN}]$$

$$P_r = 0.35F_r + 0.57F_a \quad \text{for } F_a/F_r > 1.14 \quad [\text{kN}]$$

Bearings with contact angle  $\alpha = 26^\circ$ , AA design

Bearings with contact angle  $\alpha = 25^\circ$ , A design

Single bearings and matched pairs, "T" arrangement :

$$P_r = F_r \quad \text{for } F_a/F_r \leq 0.68 \quad [\text{kN}]$$

$$P_r = 0.41F_r + 0.87F_a \quad \text{for } F_a/F_r > 0.68 \quad [\text{kN}]$$

Matched pairs, "O" and "X" arrangement :

$$P_r = F_r + 0.92F_a \quad \text{for } F_a/F_r \leq 0.68 \quad [\text{kN}]$$

$$P_r = 0.67F_r + 1.14F_a \quad \text{for } F_a/F_r > 0.68 \quad [\text{kN}]$$

Bearings with contact angle  $\alpha = 15^\circ$ , C design :

Single bearings and matched pairs, "T" arrangement :

$$P_r = F_r \quad \text{for } F_a/F_r \leq e \quad [\text{kN}]$$

$$P_r = 0.44F_r + YF_a \quad \text{for } F_a/F_r > e \quad [\text{kN}]$$

$\frac{F_a}{C_{or}}$	e	Y
0.015	0.38	1.47
0.029	0.40	1.40
0.058	0.43	1.30
0.087	0.46	1.23
0.12	0.47	1.19
0.17	0.50	1.12
0.29	0.55	1.02
0.44	0.56	1.00
0.58	0.56	1.00

i - number of bearings  
 $C_{or}$  - radial basic load rating of bearing from dimensional tables [kN]

Matched pairs, "O" and "X" arrangement :

$$P_r = F_r + Y_1 F_a \quad \text{for } F_a / F_r \leq e \quad [\text{kN}]$$

$$P_r = 0.72 F_r + Y_2 F_a \quad \text{for } F_a / F_r > e \quad [\text{kN}]$$

$\frac{F_a}{C_{or}}$	e	Y <sub>1</sub>	Y <sub>2</sub>
0.015	0.38	1.65	2.39
0.029	0.40	1.57	2.28
0.058	0.43	1.46	2.11
0.087	0.46	1.38	2.00
0.12	0.47	1.34	1.93
0.17	0.50	1.26	1.82
0.29	0.55	1.14	1.66
0.44	0.56	1.12	1.63
0.58	0.56	1.12	1.63

Bearings with contact angle  $\alpha = 12^\circ$ , CA design :

Single bearings and matched pairs, "T" arrangement :

$$P_r = F_r \quad \text{for } F_a / F_r \leq e \quad [\text{kN}]$$

$$P_r = 0.45 F_r + Y F_a \quad \text{for } F_a / F_r > e \quad [\text{kN}]$$

$\frac{F_a}{C_{or}}$	e	Y
0.014	0.30	1.81
0.029	0.34	1.62
0.057	0.37	1.46
0.086	0.41	1.34
0.11	0.45	1.22
0.17	0.48	1.13
0.29	0.52	1.04
0.43	0.54	1.01
0.57	0.54	1.00

i - number of bearings  
 $C_{or}$  - radial basic load rating of bearing from dimensional tables [kN]



Matched pairs, "O" and "X" arrangement :

$$P_r = F_r + Y_1 F_a \quad \text{for } F_a/F_r \leq e$$

$$P_r = 0.74F_r + Y_2 F_a \quad \text{for } F_a/F_r > e$$

$\frac{F_a}{C_{or}}$	e	Y <sub>1</sub>	Y <sub>2</sub>
0.014	0.30	2.08	2.94
0.029	0.34	1.84	2.63
0.057	0.37	1.69	2.37
0.086	0.41	1.52	2.18
0.11	0.45	1.39	1.98
0.17	0.48	1.30	1.84
0.29	0.52	1.20	1.69
0.43	0.54	1.16	1.64
0.57	0.54	1.16	1.62

Bearings with contact angle  $\alpha = 10^\circ$ , CB design :

Single bearings and matched pairs, "T" arrangement :

$$P_r = F_r \quad \text{for } F_a/F_r \leq e \quad [\text{kN}]$$

$$P_r = 0.46F_r + Y F_a \quad \text{for } F_a/F_r > e \quad [\text{kN}]$$

$\frac{F_a}{iC_{or}}$	e	Y
0.014	0.29	1.88
0.029	0.32	1.71
0.057	0.36	1.52
0.086	0.38	1.41
0.1100	0.40	1.34
0.1700	0.44	1.23
0.2900	0.49	1.10
0.4300	0.54	1.01
0.5700	0.54	1.00

i - number of bearings  
 $C_{or}$  - radial basic load rating of individual [kN]

Matched pairs, "O" and "X" arrangement :

$$P_r = F_r + Y_1 F_a \quad \text{for } F_a/F_r \leq e \quad [\text{kN}]$$

$$P_r = 0.46F_r + Y_2 F_a \quad \text{for } F_a/F_r > e \quad [\text{kN}]$$

$\frac{F_a}{C_{or}}$	e	Y <sub>1</sub>	Y <sub>2</sub>
0.014	0.29	2.18	3.06
0.029	0.32	1.94	2.78
0.057	0.36	1.76	2.47
0.086	0.38	1.63	2.29
0.1100	0.40	1.55	2.18
0.1700	0.44	1.42	2.00
0.2900	0.49	1.27	1.79
0.4300	0.54	1.17	1.64
0.5400	0.54	1.16	1.63

If the shaft is arranged in two single row angular contact ball bearings, the acting radial load is resolved into radial and axial components. The axial load of one bearing depends on the load and contact angle magnitude of the other bearing. These additional inner forces must be taken into account when calculating the bearing.

The following table shows relations for various bearing arrangements, when outer axial force  $K_a$ , radial force  $F_{rA}$  or  $F_{rB}$  act. Radial forces act in the intersection point of the contact line with the shaft axis (dimension "a" in the dimension tables). Force magnitude is considered only in absolute values in calculations. Calculated force  $F_a$  is given into the calculation of radial equivalent dynamic load  $P_r$ .

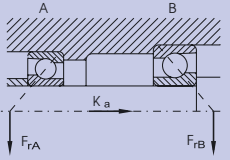
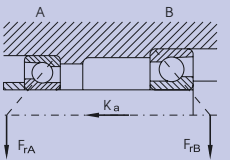
Bearing Arrangement	Force Conditions	Bearing Axial Load	
		Bearing A	Bearing B
	$\frac{F_{rA}}{Y_A} \leq \frac{F_{rB}}{Y_B}$ $K_a \geq 0$	$F_{aA} = F_{aB} + K_a$	$F_{aB} = e F_{rB}$
	$\frac{F_{rA}}{Y_A} > \frac{F_{rB}}{Y_B}$ $K_a \geq e (F_{rA} - F_{rB})$	$F_{aA} = F_{aB} + K_a$	$F_{aB} = e F_{rB}$
	$\frac{F_{rA}}{Y_A} > \frac{F_{rB}}{Y_B}$ $K_a < e (F_{rA} - F_{rB})^1$	$F_{aA} = e F_{rA}$	$F_{aB} = F_{aA} - K_a$
	$\frac{F_{rA}}{Y_A} \geq \frac{F_{rB}}{Y_B}$ $K_a \geq 0$	$F_{aA} = e F_{rA}$	$F_{aB} = F_{aA} + K_a$
	$\frac{F_{rA}}{Y_A} < \frac{F_{rB}}{Y_B}$ $K_a \geq e (F_{rB} - F_{rA})$	$F_{aA} = e F_{rA}$	$F_{aB} = F_{aA} + K_a$
	$\frac{F_{rA}}{Y_A} < \frac{F_{rB}}{Y_B}$ $K_a < e (F_{rB} - F_{rA})^1$	$F_{aA} = F_{aB} - K_a$	$F_{aB} = e F_{rB}$

<sup>1)</sup> Valid for  $K_a = 0$

For bearings with contact angle  $\alpha = 40^\circ$  (BE a B)

For bearings with contact angle  $\alpha = 26^\circ$  (AA)

For other bearings e and Y according to tables - pages 90 to 91

$e = 1.14$ ;  $Y = 0.57$

$e = 0.68$ ;  $Y = 0.87$

## Radial Equivalent Static Load

Bearings with contact angle  $\alpha = 40^\circ$ , BE and B design :

$$P_{or} = 0.5F_r + 0.26F_a \quad (P_{or} \geq F_r) \quad [\text{kN}]$$

Bearings with contact angle  $\alpha = 26^\circ$ , design AA and  $\alpha = 25^\circ$ , A design :

Single bearings and matched pairs, "T" arrangement :

$$P_{or} = 0.5F_r + 0.37F_a \quad (P_{or} \geq F_r) \quad [\text{kN}]$$

Matched pairs, "O" and "X" arrangements :

$$P_{or} = F_r + 0.74F_a \quad [\text{kN}]$$

Bearings with contact angle  $\alpha = 15^\circ$ , C design :

Single bearings and matched pairs, "T" arrangement :

$$P_{or} = 0.5F_r + 0.46F_a \quad (P_{or} \geq F_r) \quad [\text{kN}]$$

Matched pairs, "O" and "X" arrangement :

$$P_{or} = F_r + 0.92F_a \quad [\text{kN}]$$

Bearings with contact angle  $\alpha = 12^\circ$ , CA design :

Single bearings and matched pairs, "T" arrangement :

$$P_{or} = 0.5F_r + 0.47F_a \quad (P_{or} \geq F_r) \quad [\text{kN}]$$

Matched pairs, "O" and "X" arrangement :

$$P_{or} = F_r + 0.94F_a \quad [\text{kN}]$$

Bearings with contact angle  $\alpha = 10^\circ$ , CB design :

Single bearings and matched pairs, "T" arrangement „

$$P_{or} = 0.6F_r + 0.5F_a \quad (P_{or} \geq F_r) \quad [\text{kN}]$$

Matched pairs, "O" and "X" arrangement :

$$P_{or} = F_r + 0.97F_a \quad [\text{kN}]$$





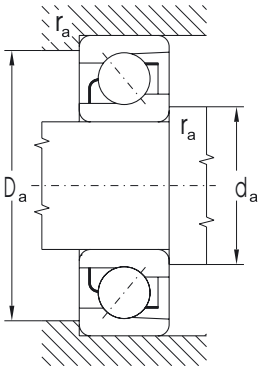

Abutment and Fillet Dimensions				Weight
d	d <sub>a</sub> min	D <sub>a</sub> max	r <sub>a</sub> max	-
mm				kg
10	14,5	25,5	0,6	0,030
12	16,5	27,5	0,6	0,037
15	19,0	31,0	0,6	0,050
	21,0	36,0	1,0	0,080
	23,0	41,0	1,0	0,120
20	23,0	41,0	1,0	0,120
	23,0	41,0	1,0	0,107
	25,0	42,0	1,0	0,110
	25,0	42,0	1,0	0,100
35	31,0	55,0	1,0	0,240
	31,0	55,0	1,0	0,235
55	42,0	71,0	1,5	0,480
	52,0	91,0	1,5	0,880
60	62,0	91,0	1,5	0,630
	65,0	110,0	2,0	1,450
60	67,0	101,0	1,5	0,800

# Single Row Angular Contact Ball Bearings for High Rotational Speed

d = 7 to 130 mm

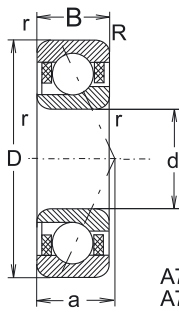

A70...TA  
A72...TA

Dimensions						Basic Load Rating		Fatigue load limit
d	D	B	r <sub>s</sub>	r <sub>1s</sub>	a	Dynamic C <sub>r</sub>	Static C <sub>or</sub>	P <sub>u</sub>
mm			min	min		kN		kN
7	22	7	0,3	0,15	5,000	2,364	0,90	0,041
9	26	8	0,6	0,30	5,500	3,891	1,64	0,075
10	30	9	0,6	0,30	6,000	5,335	2,29	0,104
	30	9	0,6	0,30	6,500	7,124	2,90	0,132
	30	9	0,6	0,30	7,000	7,729	3,28	0,149
	30	9	0,6	0,30	7,180	4,387	2,10	0,095
	30	9	0,6	0,30	9,000	7,529	3,20	0,145
	30	9	0,6	0,30	9,160	4,181	2,00	0,091
12	32	10	0,6	0,30	7,000	5,880	2,65	0,120
	32	10	0,6	0,30	7,500	7,980	3,46	0,157
	32	10	0,6	0,30	8,000	8,622	3,89	0,177
	32	10	0,6	0,30	10,000	8,275	3,78	0,172
	32	10	0,6	0,30	10,500	7,505	3,21	0,146
15	32	9	0,3	0,15	7,648	4,695	2,30	0,105
	32	9	0,3	0,15	9,980	6,622	3,20	0,145
	32	9	0,3	0,15	9,980	4,490	2,20	0,100
	32	9	0,3	0,30	7,648	6,955	3,50	0,159
	35	11	0,6	0,30	7,500	6,940	3,45	0,157
	35	11	0,6	0,30	8,000	8,855	4,18	0,190
	35	11	0,6	0,30	11,000	9,078	4,44	0,202
	35	11	0,6	0,60	9,000	9,483	4,59	0,209
17	35	10	0,3	0,15	8,480	6,235	3,40	0,155
	35	10	0,3	0,15	16,780	7,562	4,25	0,193
	35	10	0,3	0,15	16,780	5,916	3,00	0,136
	35	10	0,3	0,30	8,480	7,896	4,45	0,202
	40	12	0,6	0,30	8,500	8,362	4,25	0,193
	40	12	0,6	0,30	9,000	10,904	5,29	0,240
	40	12	0,6	0,30	13,000	11,182	5,62	0,255
	40	12	0,6	0,60	10,000	11,631	5,82	0,265
20	42	12	0,6	0,30	9,150	11,899	6,20	0,282
	42	12	0,6	0,30	9,150	7,940	4,20	0,191
	42	12	0,6	0,30	12,220	11,707	6,00	0,273
	42	12	0,6	0,30	12,220	7,740	4,00	0,182
	47	14	1,0	0,60	10,000	10,224	5,54	0,252
	47	14	1,0	0,60	10,500	14,572	7,32	0,333
	47	14	1,0	0,60	12,000	15,685	8,06	0,366
	47	14	1,0	0,60	14,000	14,952	7,77	0,353
	47	14	1,0	0,60	15,000	13,897	6,99	0,318
25	47	12	0,6	0,30	10,320	13,750	8,60	0,391
	47	12	0,6	0,30	10,320	9,532	5,70	0,259
	47	12	0,6	0,30	13,890	13,186	8,20	0,373
	47	12	0,6	0,30	13,890	9,121	5,60	0,255
	52	15	1,0	0,60	11,000	14,091	7,96	0,362
	52	15	1,0	0,60	11,500	15,921	8,63	0,392
	52	15	1,0	0,60	13,000	17,679	10,28	0,467
	52	15	1,0	0,60	16,000	16,917	9,81	0,446
	52	15	1,0	0,60	17,000	14,895	8,15	0,370
30	55	13	1,0	0,60	12,200	16,234	10,30	0,468
	55	13	1,0	0,60	12,200	11,331	7,20	0,327
	55	13	1,0	0,60	25,850	15,515	10,10	0,459
	55	13	1,0	0,60	25,850	10,817	6,90	0,314
	62	16	1,0	0,60	12,000	18,020	10,72	0,487
	62	16	1,0	0,60	13,000	22,072	12,42	0,565
	62	16	1,0	0,60	14,000	24,734	14,72	0,669
	62	16	1,0	0,60	19,000	20,877	11,58	0,526
	62	16	1,0	0,60	19,000	23,483	14,07	0,640
35	62	14	1,0	0,60	13,490	20,680	14,40	0,655
	62	14	1,0	0,60	13,490	14,298	10,00	0,455
	62	14	1,0	0,60	18,500	18,476	12,05	0,548

\*\* Bearings in the new standard NEW FORCE (see the catalogue NEW FORCE)

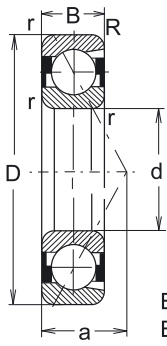

B70...TA  
B72...TA

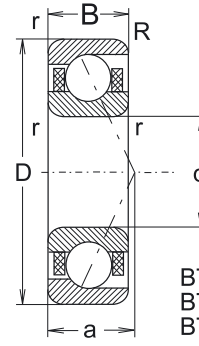

B70...TB  
B72...TB  
B72...MB



Limiting Speed for Lubrication with		Axial preload of coupled bearings			Bearing Designation	Weight ~ kg
Grease	Oil	L	M	S		
min <sup>-1</sup>		N				
94000	140000				A727CBTA**	0,013
71000	106000				A729CBTA**	0,020
60000	89000	20	70	140	B7200CBTB**	0,027
42000	63000	33	105	213	B7200CATB**	0,028
56000	85000	45	140	280	B7200CTA**	0,030
65000	100000	15	60	130	CB7200CTA**	0,028
50000	75000	65	240	450	B7200ATA**	0,030
55000	85000	22	80	195	CB7200ATA**	0,028
56000	84000	22	77	154	B7201CBTB**	0,035
38000	56000	37	118	235	B7201CATB**	0,036
50000	75000	50	160	320	B7201CTA**	0,037
45000	67000	75	270	540	B7201ATA**	0,037
33000	50000				AC7201ATA***	0,036
55000	85000	11	52	115	CB7002CTA**	0,043
40000	65000	37	155	355	B7002ATA**	0,043
50000	72000	18	68	170	CB7002ATA**	0,043
45000	70000	30	110	225	B7002CTA**	0,043
50000	75000	25	90	180	B7202CBTB**	0,042
33000	50000	41	132	264	B7202CATB**	0,043
40000	60000	80	290	590	B7202ATA**	0,045
45000	67000	55	170	350	B7202CTA**	0,045
55000	80000	18	75	165	CB7003CTA**	0,039
38000	56000	50	190	420	B7003ATA**	0,039
45000	65000	30	100	230	CB7003ATA**	0,039
44000	67500	40	150	260	B7003CTA**	0,039
45000	67000	31	109	219	B7203CBTB**	0,060
28000	42000	51	163	326	B7203CATB**	0,061
36000	53000	100	360	730	B7203ATA**	0,064
38000	56000	70	210	430	B7203CTA**	0,064
39000	57000	55	180	400	B7004CTA**	0,066
45000	65000	25	100	200	CB7004CTA**	0,066
35000	50000	75	290	645	B7004ATA**	0,066
35000	55000	30	120	300	CB7004ATA**	0,066
40000	60000	38	134	268	B7204CBTB**	0,098
25000	38000	68	218	437	B7204CATB**	0,100
32000	48000	90	290	580	B7204CTA**	0,103
30000	45000	140	490	950	B7204ATA**	0,103
22000	33000	156	455	910	B7204AATB**	0,102
35000	50000	65	220	470	B7005CTA**	0,080
40000	55000	30	120	250	CB7005CTA**	0,080
30000	45000	100	360	740	B7005ATA**	0,080
35000	50000	35	180	410	CB7005ATA**	0,080
33000	50000	53	183	367	B7205CBTB**	0,119
22000	33000	74	237	474	B7205CATB**	0,122
28000	43000	100	330	650	B7205CTA**	0,125
26000	40000	155	550	1100	B7205ATA**	0,125
20000	30000	167	488	977	B7205AATB**	0,124
26000	40000	75	260	555	B7006CTA**	0,115
30000	45000	37	140	300	CB7006CTA**	0,115
24000	38000	105	405	885	B7006ATA**	0,115
28000	43000	40	200	450	CB7006ATA**	0,115
28000	42000	67	235	470	B7206CBTB**	0,184
20000	30000	102	325	655	B7206CATB**	0,189
24000	38000	140	450	910	B7206CTA**	0,193
17000	25000	233	679	1740	B7206AATB**	0,192
22000	36000	220	770	1530	B7206ATA**	0,193
22000	36000	100	330	710	B7007CTA**	0,155
30000	45000	48	180	380	CB7007CTA**	0,155
9400	11000	207	605	1210	B7007AATB**	0,148

# Single Row Angular Contact Ball Bearings for High Rotational Speed

d = 7 to 130 mm

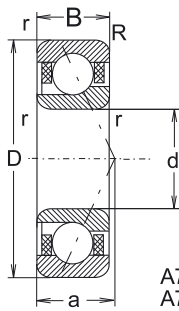

A70...TA  
A72...TA

d	Dimensions					Basic Load Rating		Fatigue load limit P <sub>u</sub>
	D	B	r <sub>s</sub> min	r <sub>1s</sub> min	a	Dynamic C <sub>r</sub>	Static C <sub>or</sub>	
mm						kN		kN
35	62	14	1,0	0,60	28,980	20,097	13,25	0,602
	62	14	1,0	0,60	28,980	13,910	9,40	0,427
	72	17	1,1	0,60	10,000	29,131	17,40	0,791
	72	17	1,1	0,60	13,000	22,523	14,34	0,652
	72	17	1,1	0,60	14,000	31,042	18,60	0,845
	72	17	1,1	0,60	15,000	32,929	20,29	0,922
	72	17	1,1	0,60	16,000	32,669	20,04	0,911
	72	17	1,1	0,60	21,000	31,002	19,10	0,868
40	68	15	1,0	0,60	14,730	21,960	16,10	0,732
	68	15	1,0	0,60	14,730	15,151	11,00	0,500
	68	15	1,0	0,60	20,100	20,933	15,20	0,691
	68	15	1,0	0,60	20,100	14,111	10,60	0,482
	68	15	1,0	0,60	20,500	19,859	14,13	0,642
	80	18	1,1	0,60	14,000	26,240	17,30	0,786
	80	18	1,1	0,60	15,500	39,375	23,77	1,080
	80	18	1,1	0,60	17,000	41,450	26,02	1,183
45	80	18	1,1	0,60	23,000	39,759	24,90	1,132
	68	12	0,6	0,30	13,000	16,018	12,60	0,573
	68	12	0,6	0,30	13,000	11,502	9,10	0,414
	68	12	0,6	0,30	18,190	15,137	12,00	0,545
	68	12	0,6	0,30	18,190	10,777	8,80	0,400
	75	16	1,0	0,60	0,030	27,020	20,40	0,927
	75	16	1,0	0,60	16,030	18,921	14,30	0,650
	75	16	1,0	0,60	21,980	25,680	19,30	0,877
	75	16	1,0	0,60	21,980	17,993	13,50	0,614
	85	19	1,1	0,60	15,000	30,327	20,31	0,923
50	85	19	1,1	0,60	16,500	39,540	24,61	1,119
	85	19	1,1	0,60	18,000	43,841	28,81	1,310
	85	19	1,1	0,60	25,000	41,893	27,54	1,252
	80	16	1,0	0,60	15,800	24,133	18,52	0,842
	80	16	1,0	0,60	19,730	27,716	21,80	0,991
	80	16	1,0	0,60	19,730	19,740	15,30	0,695
	80	16	1,0	0,60	23,150	26,273	20,80	0,945
	80	16	1,0	0,60	23,150	18,708	14,60	0,664
	90	20	1,1	0,60	16,000	34,593	23,56	1,071
	90	20	1,1	0,60	17,500	41,758	27,26	1,239
55	90	20	1,1	0,60	19,000	45,871	31,73	1,442
	90	20	1,1	0,60	26,000	39,229	25,92	1,178
	90	20	1,1	0,60	26,000	43,970	30,08	1,367
	90	18	1,1	0,60	26,500	33,314	25,38	1,154
	100	21	1,5	1,00	17,000	41,229	29,12	1,324
	100	21	1,5	1,00	18,500	51,719	34,50	1,568
	100	21	1,5	1,00	21,000	56,847	39,92	1,815
	100	21	1,5	1,00	29,000	54,288	38,23	1,738
60	95	18	1,1	1,00	21,660	38,610	32,00	1,455
	95	18	1,1	1,00	21,660	27,085	22,40	1,018
	95	18	1,1	1,00	27,100	36,807	30,40	1,382
	95	18	1,1	1,00	27,100	25,810	21,30	0,968
	110	22	1,5	1,00	18,000	47,450	33,80	1,536
	110	22	1,5	1,00	20,000	64,377	42,60	1,936
	110	22	1,5	1,00	22,000	70,784	49,07	2,230
	110	22	1,5	1,00	31,000	67,627	47,07	2,140
65	110	22	1,5	1,00	32,000	60,741	39,96	1,816
	120	23	1,5	1,00	21,500	78,185	54,78	2,490
	120	23	1,5	1,00	24,000	81,130	58,70	2,668
	120	23	1,5	1,00	33,000	76,670	56,06	2,548
70	110	20	1,1	0,60	22,060	53,288	45,00	2,045
	110	20	1,1	0,60	22,060	36,807	31,20	1,418
	110	20	1,1	0,60	30,990	50,628	42,90	1,950

\*\* Bearings in the new standard NEW FORCE (see the catalogue NEW FORCE)



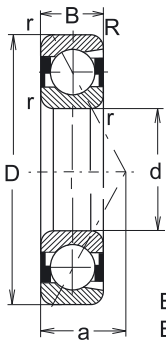

B70...TA  
B72...TA

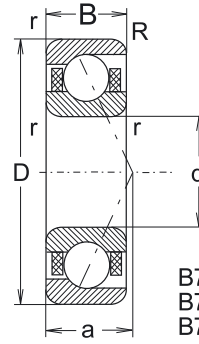

B70...TB  
B72...TB  
B72...MB

Limiting Speed for Lubrication with		Axial preload of coupled bearings			Bearing Designation	Weight ~ kg
Grease	Oil	L	M	S		
min <sup>-1</sup>		N				
20000	32000	140	530	1150	B7007ATA**	0,155
25000	40000	60	270	600	CB7007ATA**	0,155
13000	20000	326	952	1900	B7207AATB**	0,281
25000	38000	84	280	588	B7207CBTB**	0,268
16000	24000	144	462	925	B7207CATB**	0,275
16000	24000	153	490	981	B7207CAMB**	0,323
20000	34000	185	600	1200	B7207CTA**	0,280
19000	32000	290	1010	2010	B7207ATA**	0,280
20000	34000	105	350	755	B7008CTA**	0,185
26000	40000	50	190	410	CB7008CTA**	0,185
19000	30000	150	560	1200	B7008ATA**	0,185
22000	35000	60	280	630	CB7008ATA**	0,185
8400	10000	222	645	1290	B7008AATB**	0,185
22000	33000	98	343	686	B7208CBTB**	0,337
13000	20000	180	587	1170	B7208CATB**	0,347
18000	30000	235	770	1540	B7208CTA**	0,350
17000	28000	370	1100	2500	B7208ATA**	0,350
20000	32000	90	320	535	B71909CTA**	0,130
25000	38000	35	140	310	CB71909CTA**	0,110
18000	30000	100	390	840	B71909ATA**	0,130
22000	35000	70	200	450	CB71909ATA**	0,110
18000	30000	140	470	935	B7009CTA**	0,260
23000	37000	70	250	530	CB7009CTA**	0,230
17000	28000	195	750	1500	B7009ATA**	0,260
21000	33000	85	370	840	CB7009ATA**	0,230
20000	30000	113	396	792	B7209CBTB**	0,381
12600	19000	184	590	1175	B7209CATB**	0,381
17000	28000	250	810	1630	B7209CTA**	0,387
15000	24000	390	1200	2710	B7209ATA**	0,387
9500	11000	270	793	1580	B7010AATB**	0,253
17000	28000	150	510	965	B7010CTA**	0,250
22000	35000	75	280	580	CB7010CTA**	0,210
15000	24000	210	750	1550	B7010ATA**	0,250
18000	30000	90	400	880	CB7010ATA**	0,210
18000	27000	129	450	905	B7210CBTB**	0,432
12000	18000	195	623	1245	B7210CATB**	0,443
16000	26000	260	850	1710	B7210CTA**	0,448
10600	16000	438	1275	2550	B7210AATB**	0,447
14000	20000	400	1400	2810	B7210ATA**	0,448
6300	7500	371	1080	2160	B7011AATB**	0,395
17000	25000	153	538	1075	B7211CBTB**	0,567
11000	17000	241	771	1540	B7211CATB**	0,582
14000	22000	320	1010	2100	B7211CTA**	0,586
13000	20000	500	1710	3500	B7211ATA**	0,586
14000	22000	210	700	1305	B7012CTA**	0,410
18000	30000	100	360	780	CB7012CTA**	0,350
13000	20000	290	1000	2100	B7012ATA**	0,410
15000	25000	130	540	1150	CB7012ATA**	0,350
15000	22000	172	602	1200	B7212CBTB**	0,735
10000	15000	291	932	1860	B7212CATB**	0,754
13000	20000	380	1200	2500	B7212CTA**	0,754
12000	19000	610	2130	4200	B7212ATA**	0,754
8900	13000	657	1915	3830	B7212AATB**	0,759
8900	13000	352	1128	2250	B7213CATB**	0,994
12000	19000	440	1400	2900	B7213CTA**	0,999
11000	18000	700	2410	4810	B7213ATA**	0,999
13000	19000	280	930	1825	B7014CTA**	0,600
15000	25000	140	500	1020	CB7014CTA**	0,500
11000	17000	390	1390	2910	B7014ATA**	0,600

# Single Row Angular Contact Ball Bearings for High Rotational Speed

d = 7 to 130 mm

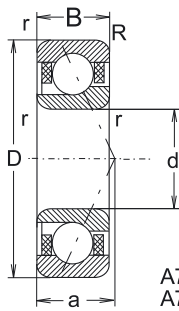

A70...TA  
A72...TA

Dimensions						Basic Load Rating		Fatigue load limit
d	D	B	r <sub>s</sub>	r <sub>1s</sub>	a	Dynamic C <sub>r</sub>	Static C <sub>0r</sub>	P <sub>u</sub>
mm						kN		kN
70	110	20	1,1	0,60	32,000	45,430	36,46	1,657
	125	24	1,5	1,00	20,500	64,709	47,66	2,166
	125	24	1,5	1,00	22,500	84,775	60,13	2,733
	125	24	1,5	1,00	25,000	87,597	64,55	2,934
	125	24	1,5	1,00	30,990	35,567	21,80	0,991
	125	24	1,5	1,00	35,000	83,397	61,56	2,798
75	130	25	1,5	1,00	23,500	84,948	61,39	2,756
	130	25	1,5	1,00	26,000	87,285	65,44	2,938
	130	25	1,5	1,00	36,000	83,103	62,52	2,807
	130	25	1,5	1,00	37,500	82,540	62,49	2,806
	130	25	1,5	1,00	37,500	78,887	58,32	2,618
80	125	22	1,1	0,60	22,000	61,117	50,01	2,245
	125	22	1,1	0,60	24,730	66,963	57,50	2,582
	125	22	1,1	0,60	24,730	46,894	40,20	1,805
	125	22	1,1	0,60	34,900	64,095	55,10	2,474
	125	22	1,1	0,60	34,900	44,874	38,60	1,733
	125	22	1,1	0,60	36,000	59,265	49,44	2,220
	140	26	2,0	1,00	24,500	99,345	73,05	3,166
	140	26	2,0	1,00	28,000	102,080	77,56	3,361
	140	26	2,0	1,00	39,000	97,328	73,95	3,205
	140	26	2,0	1,00	40,000	92,645	68,04	2,949
85	130	22	1,1	0,60	25,400	68,386	58,70	2,573
	130	22	1,1	0,60	25,400	47,914	41,40	1,815
	130	22	1,1	0,60	30,060	67,847	58,20	2,552
	130	22	1,1	0,60	30,060	47,558	40,70	1,784
	130	22	1,1	0,60	37,000	60,265	52,69	2,310
	130	28	1,1	0,60	37,000	62,314	55,33	2,426
	150	28	2,0	1,00	26,500	111,477	86,08	3,610
	150	28	2,0	1,00	30,000	115,662	88,55	3,713
	150	28	2,0	1,00	42,000	108,988	86,45	3,625
	150	28	1,00	1,00	42,500	103,780	80,67	3,383
90	140	24	1,5	1,00	24,000	74,528	62,47	2,648
	140	24	1,5	1,00	27,410	81,622	72,40	3,069
	140	24	1,5	1,00	27,410	57,187	57,90	2,454
	140	24	1,5	1,00	38,810	77,461	69,00	2,925
	140	24	1,5	1,00	38,810	54,305	40,50	1,717
	140	24	1,5	1,00	40,000	72,276	61,75	2,617
	180	34	2,1	1,10	51,000	156,339	120,96	4,732
100	150	24	1,5	0,60	28,750	89,607	80,80	3,285
	150	24	1,5	0,60	28,750	61,827	55,70	2,265
	150	24	1,5	0,60	41,150	84,040	76,40	3,106
	150	24	1,5	0,60	41,150	58,023	52,70	2,143
	180	34	2,1	1,10	35,760	105,682	86,00	3,304
	180	34	2,1	1,10	36,000	171,671	136,01	5,225
	180	34	2,1	1,10	49,770	98,808	83,00	3,189
	180	34	2,1	1,10	50,000	164,214	129,98	4,993
110	140	16	1,0	0,60	24,700	44,428	49,60	2,017
	140	16	1,0	0,60	34,000	42,287	46,30	1,882
120	180	28	2,0	1,00	30,000	112,019	103,66	3,847
	180	28	2,0	1,00	34,100	114,338	107,80	4,001
	180	28	2,0	1,00	34,100	78,921	75,40	2,798
	180	28	2,0	1,00	48,980	107,543	102,10	3,789
	180	28	2,0	1,00	48,980	74,299	71,50	2,654
	180	28	2,0	1,00	50,500	106,191	101,28	3,759
130	165	11	1,0	0,50	41,500	14,903	19,10	0,715

\*\* Bearings in the new standard NEW FORCE (see the catalogue NEW FORCE)

\*\*\* Separable bearing dedicated to separable arrangements of textile spindles parts

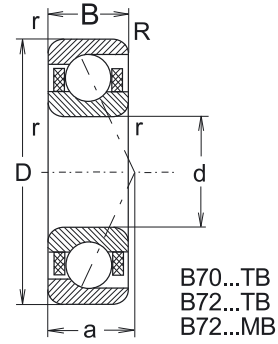
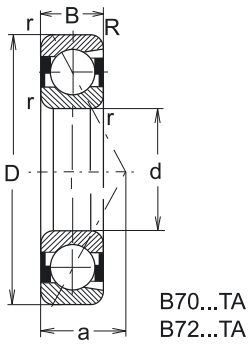

Limiting Speed for Lubrication with		Axial preload of coupled bearings			Bearing Designation	Weight ~ kg
Grease	Oil	L	M	S		
min <sup>-1</sup>		N				
7900	12000	493	1140	2050	<b>B7014AATB**</b>	0,597
12600	19000	234	820	1640	<b>B7214CBTB**</b>	1,040
7900	12000	373	1190	2350	<b>B7214CATB**</b>	1,070
11000	18000	480	1540	3170	<b>B7214CTA**</b>	1,090
14000	20000	180	720	1600	<b>CB7014ATA**</b>	0,500
10000	17000	760	2620	5300	<b>B7214ATA**</b>	1,090
7500	11000	383	1250	2450	<b>B7215CATB**</b>	1,160
11000	18000	480	1560	3170	<b>B7215CTA**</b>	1,170
9500	16000	760	2640	5210	<b>B7215ATA**</b>	1,170
4200	5000	898	2620	5240	<b>B7215AAMB**</b>	1,390
6700	10000	858	2500	500	<b>B7215AATB**</b>	1,260
7500	11000	276	885	1770	<b>B7016CATB**</b>	0,841
10000	18000	350	1140	2290	<b>B7016CTA**</b>	0,850
14000	22000	180	620	1350	<b>CB7016CTA**</b>	0,710
9000	15000	500	1800	3700	<b>B7016ATA**</b>	0,850
13000	20000	250	950	1950	<b>CB7016ATA**</b>	0,710
6700	10000	267	855	1710	<b>B7016AATB**</b>	0,848
6700	10000	447	1432	2860	<b>B7216CATB**</b>	1,410
10000	17000	560	1840	3700	<b>B7216CTA**</b>	1,430
9000	15000	880	3050	6110	<b>B7216ATA**</b>	1,430
6300	9400	1008	2940	5880	<b>B7216AATB**</b>	1,420
10000	17000	380	1240	2350	<b>B7017CTA**</b>	0,910
12000	19000	190	640	1400	<b>CB7017CTA**</b>	0,770
9000	15000	540	1870	3900	<b>B7017ATA**</b>	0,910
10000	18000	260	1000	2100	<b>CB7017ATA**</b>	0,770
4200	5000	653	1900	3800	<b>B7017AATA**</b>	0,912
6300	9400	675	1970	3940	<b>B7017AAMB**</b>	1,060
6300	9400	502	1608	3210	<b>B7217CATB**</b>	1,800
9000	15000	630	2010	4150	<b>B7217CTA**</b>	1,820
8000	13000	1000	3450	6910	<b>B7217ATA**</b>	1,820
6000	8900	1310	3290	6590	<b>B7217AATB**</b>	1,820
6300	9400	338	1080	2160	<b>B7018CATB**</b>	1,150
10000	16000	450	1450	2800	<b>B7018CTA**</b>	1,150
12000	19000	230	760	1590	<b>CB7018CTA**</b>	0,970
9000	15000	620	2200	4580	<b>B7018ATA**</b>	1,150
10000	17000	315	1150	2550	<b>CB7018ATA**</b>	0,970
4000	4700	783	2280	4570	<b>B7018AATB**</b>	1,160
5300	7900	1690	4930	9870	<b>B7220AATB**</b>	3,320
8000	14000	470	1520	3070	<b>B7020CTA**</b>	1,290
11000	18000	235	815	1700	<b>CB7020CTA**</b>	1,100
7000	12000	680	2340	4950	<b>B7020ATA**</b>	1,290
9000	15000	335	1265	2710	<b>CB7020ATA**</b>	1,100
10000	15000	450	1460	2950	<b>CB7220CTA**</b>	2,890
7500	12000	940	3100	6220	<b>B7220CTA**</b>	3,320
8000	13000	640	2200	5580	<b>CB7220ATA**</b>	2,890
6700	10000	1480	5200	10100	<b>B7220ATA**</b>	3,320
8000	13000	200	700	1500	<b>B71822CTA**</b>	0,500
7000	11000	350	900	2000	<b>B71822ATA**</b>	0,500
5000	7500	505	1617	3230	<b>B7024CATB**</b>	2,100
7000	10000	670	2000	4100	<b>B7024CTA**</b>	2,100
9000	14000	320	1100	2220	<b>CB7024CTA**</b>	1,850
6000	9000	950	3200	6550	<b>B7024ATA**</b>	2,100
8000	12000	450	1680	3550	<b>CB7024ATA**</b>	1,850
3000	3500	1153	3363	6727	<b>B7024AATB**</b>	2,090
3200	3800				<b>B70826AAMB**</b>	0,635

# Double Row Angular Contact Ball Bearings

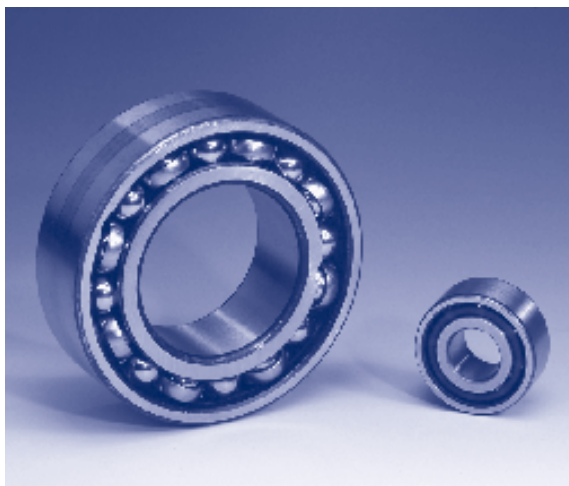

Double row angular contact ball bearings principally correspond to a matched pair of single row angular contact ball bearings in an “O” arrangement. At the same size (d and D) the matched pair has a smaller width.

The bearing has a filling slot on one side. If axial forces, which act in one direction, prevail, the bearing should be mounted so that the forces should not act against the filling slot. They can also be supplied equipped with plastic cage PA6 or PA66, designation TNG.

Bearing design enables the contact angle  $\alpha = 32^\circ$ . That is why they can carry tilting moments in the axial plane. If there is lack of space only one bearing is sufficient for arranging a rotating part.

## Boundary Dimensions

Boundary dimensions comply with the standard ISO 15 and are shown in the dimension tables of this publication.

## Designation

Bearing designation in standard design is a part of data in the dimension tables. The difference from standard design is designated by additional symbols (section 2.2).

## Cage

Double row angular contact ball bearings have cages pressed of steel sheet. They are not indicated. This is not valid for bearings with plastic cage (TNG) because they are not equipped with filling slot.

## Tolerance

Bearings are commonly produced in normal tolerance class P0, it is not indicated. For more demanding arrangements bearings in higher tolerance class P6 are produced.

Limiting values of dimension and running accuracy are in tables 10 and 11 and comply with standards ISO 199 and ISO 492.

## Axial Clearance

Bearings are commonly produced with normal axial clearance, it is not indicated. For special arrangements bearings with smaller C2 and greater C3 and C4 axial clearance are delivered.

## Misalignment

Bearings form a very rigid arrangement especially sensitive to rings misalignment caused by mounting inaccuracies.

### Radial Equivalent Dynamic Load

$$\begin{aligned} P_r &= F_r + 0.73F_a && \text{for } F_a/F_r \leq 0.86 \\ P_r &= 0.62F_r + 1.17F_a && \text{for } F_a/F_r > 0.86 \end{aligned}$$

### Radial Equivalent Static Load

$$P_{or} = F_r + 0.63F_a$$



# Double Row Angular Contact Ball Bearings

d = 10 to 75 mm

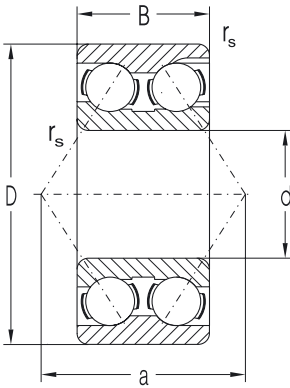

Dimensions					Basic Load Rating		Fatigue load limit		Limiting Speed for Lubrication with Grease Oil		Bearing Designation
d	D	B	r <sub>s</sub>	a	Dynamic C <sub>r</sub>	Static C <sub>0r</sub>	P <sub>u</sub>				
mm					kN		kN	kN	min <sup>-1</sup>		
10	30	14,0	0,6	20	9,253	5,840	0,265		16000	19000	<b>3200X**</b>
	30	14,3	0,6	20	9,253	5,840	0,265		16000	19000	<b>3200**</b>
12	32	15,9	0,6	22	11,050	7,080	0,322		14000	17000	<b>3201**</b>
15	35	15,9	0,6	23	10,381	7,500	0,341		13000	16000	<b>3202**</b>
	42	19,0	1,0	27	17,369	11,900	0,541		10600	12600	<b>3202**</b>
17	40	17,5	0,6	27	14,418	10,600	0,482		11000	13000	<b>3203**</b>
	47	22,2	1,0	31	23,649	16,200	0,736		9400	11000	<b>3203**</b>
20	47	20,6	1,0	31	19,905	15,000	0,682		9400	11000	<b>3204**</b>
	52	22,2	1,1	34	23,656	18,500	0,841		8400	10000	<b>3204**</b>
25	52	20,6	1,0	35	21,539	18,100	0,823		8400	10000	<b>3205**</b>
	62	25,4	1,1	40	32,881	26,600	1,209		7100	8400	<b>3205**</b>
30	62	23,8	1,0	41	30,998	27,100	1,232		7100	8400	<b>3206**</b>
	72	30,2	1,1	47	43,688	36,200	1,645		6000	7100	<b>3206**</b>
35	72	27,0	1,1	47	42,125	37,600	1,709		6000	7100	<b>3207**</b>
	80	34,9	1,5	54	56,219	47,300	2,150		5300	6300	<b>3207**</b>
40	80	30,2	1,1	52	48,186	43,800	1,991		5300	6300	<b>3208**</b>
	90	36,5	1,5	58	59,431	59,600	2,709		4700	5600	<b>3208**</b>
45	85	30,2	1,1	56	51,994	51,100	2,323		5000	6000	<b>3209**</b>
	100	39,7	1,5	64	82,479	73,600	3,345		4200	5000	<b>3209**</b>
50	90	30,2	1,1	59	59,553	58,400	2,655		4500	5300	<b>3210**</b>
	110	44,4	2,0	73	99,898	96,200	4,373		3800	4500	<b>3210**</b>
55	100	33,3	1,5	64	74,481	66,800	3,036		4200	5000	<b>3211**</b>
	120	49,2	2,0	80	110,379	108,000	4,909		3300	4000	<b>3211**</b>
60	110	36,5	1,5	71	82,491	85,800	3,900		3800	4500	<b>3212**</b>
	130	54,0	2,1	86	128,709	128,000	5,818		3200	3800	<b>3212**</b>
65	120	38,1	1,5	76	90,746	94,400	4,291		3500	4200	<b>3213**</b>
	140	58,7	2,1	94	146,328	147,000	6,600		3000	3500	<b>3213**</b>
70	125	39,7	1,5	81	87,349	98,100	4,459		3200	3800	<b>3214**</b>
	75	130	41,3	1,5	84	96,151	110,000	4,939		3200	3800

\*\* Bearings in the new standard NEW FORCE (see the catalogue NEW FORCE)

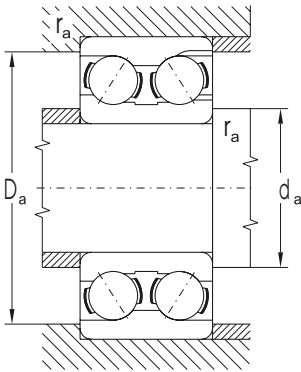

Abutment and Fillet Dimensions				Weight
d	d <sub>a</sub> min	D <sub>a</sub> max	r <sub>a</sub> max	-
mm				kg
10	14	25	0,6	0,05
	14	25	0,6	0,05
12	16	27	0,6	0,06
15	19	30	0,6	0,07
	21	36	1,0	0,13
17	21	35	0,6	0,10
	23	41	1,0	0,19
20	25	42	1,0	0,17
	27	45	1,0	0,23
25	30	46	1,0	0,19
	32	55	1,0	0,37
30	35	56	1,0	0,31
	37	65	1,0	0,58
35	41	65	1,0	0,48
	44	71	1,5	0,78
40	46	73	1,0	0,65
	49	81	1,5	1,05
45	51	78	1,0	0,70
	54	91	1,5	1,41
50	56	83	1,0	0,74
	60	100	2,0	1,90
55	62	91	1,5	1,05
	65	110	2,0	2,48
60	67	101	1,5	1,36
	72	118	2,0	3,17
65	72	111	1,5	1,76
	77	128	2,0	4,01
70	77	116	1,5	1,93
75	82	121	1,5	2,08

# Double Row Self-Aligning Ball Bearings



These bearings are designed with two rows of balls and a spherical raceway in the outer ring. This allows certain misalignment of the inner ring against outer ring around bearing centre without the bearing function being threatened. Bearings are produced with cylindrical and tapered bore and are non-separable. Misalignment ability by not changed functionality determine this bearings to utilize where some bore misalignment in housings or deflection and shaft oscillation are presumed. With respect to a small contact angle and imperfect conformity of balls to raceways they are not suitable for accommodating larger axial forces.

## Boundary Dimensions

Boundary dimensions comply with the standard ISO 15 and are shown in the dimension tables of this publication.

## Designation

Bearing designation in standard design and in design with tapered bore is in the dimension tables. Difference from standard design is designated by additional symbols (section 2.2).

## Tapered Bore

Bearings with tapered bore have taper 1:12. Bearings are fixed on cylindrical shafts by means of adapter sleeves. Adapter sleeves designation corresponding to individual bearings is in the dimension tables of this publication.

## Cage

Bearings have the standard design cages according to the following table (material symbol and cage design are mostly not indicated).

Bearings with Pressed Steel or Brass Cage	Bearings with Machined Brass or Steel Cage
d<10mm, 126	-
1200 to 1222	1224 to 1230
2200 to 2222	-
1300 to 1322	1324
2304 to 2320 <sup>1)</sup>	2322

<sup>1)</sup> Bearing 2305 is produced with a solid cage with filling (TNGN)



## Tolerance

Bearings are commonly produced in normal tolerance class P0 which is not indicated. Bearings for more demanding arrangements are delivered in tolerance class P6.

Limiting values of dimension and running accuracy are shown in tables 10 and 11 and comply with the standards ISO 199 and ISO 492.

## Radial Clearance

Bearings commonly produced have a normal clearance which is not indicated. For special arrangements bearings with smaller radial clearance C2 or greater radial clearance C3, C4 and C5 are delivered.

## Misalignment

Values of permissible bearing misalignment for keeping its functionality are shown in the following table.

Bearing Type	Permissible misalignment
d < 10mm	3°
126, 13, 23 12, 22	2°30'

## Radial Equivalent Dynamic Load

$$\begin{aligned} P_r &= F_r + Y_1 F_a & \text{pro } F_a / F_r \leq e & \quad [\text{kN}] \\ P_r &= 0.65 F_r + Y_2 F_a & \text{pro } F_a / F_r > e & \quad [\text{kN}] \end{aligned}$$

Factor values  $e$ ,  $Y_1$  and  $Y_2$  for individual bearings are shown in the dimension tables of this publication.

## Radial Equivalent Static Load

$$P_{or} = F_r + Y_0 F_a \quad [\text{kN}]$$

Factor values  $Y_0$  for individual bearings are shown in the dimension tables of this publication.



# Double Row Self-Aligning Ball Bearings

d = 6 to 60 mm

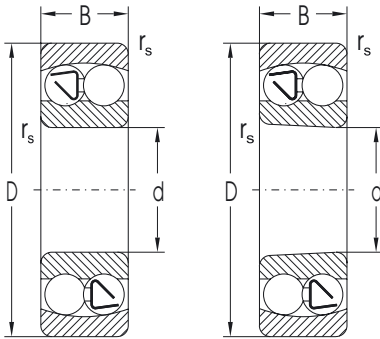

K

Dimensions					Basic Load Dynamic $C_r$	Rating Static $C_{or}$	Fatigue load limit $P_u$	Limiting Speed for Lubrication with		Bearing Designation	
d	D	B	$B_1^{(1)}$	$r_s$				Grease	Oil	with Cylindrical Bore	with Tapered Bore
mm					kN		kN	min <sup>-1</sup>			
10	30	14		0,6	7,28	1,58	0,07	25000	30000	<b>2200</b>	
12	32	10		0,6	5,59	1,26	0,06	24000	28000	<b>1201</b>	
15	35	11		0,6	7,41	1,74	0,08	21000	25000	<b>1202</b>	
	35	14		0,6	7,61	1,81	0,08	21000	25000	<b>2202</b>	
17	40	12		0,6	8,14	2,03	0,09	17000	20000	<b>1203**</b>	<b>1203K</b>
20	47	14		1,0	10,24	2,66	0,12	14000	17000	<b>1204**</b>	<b>1204K</b>
25	52	15		1,0	12,46	3,35	0,15	12600	15000	<b>1205**</b>	<b>1205K</b>
	52	18		1,0	12,88	3,48	0,16	12600	15000	<b>2205**</b>	<b>2205K</b>
	62	17		1,1	18,49	5,01	0,23	10000	13000	<b>1305**</b>	<b>1305K</b>
	62	24		1,1	25,24	6,56	0,30	10000	12000	<b>2305TNGN**2305KTNGN</b>	
30	62	16		1,0	16,69	4,73	0,22	11000	13000	<b>1206**</b>	<b>1206K</b>
	62	20		1,0	15,76	4,55	0,21	11000	13000	<b>2206**</b>	<b>2206K</b>
	72	19		1,1	22,04	6,31	0,29	9400	11000	<b>1306**</b>	<b>1306K</b>
35	72	27		1,1	32,34	8,74	0,40	8400	10000	<b>2306**</b>	<b>2306K</b>
	72	17		1,1	16,27	5,11	0,23	9400	11000	<b>1207**</b>	<b>1207K</b>
40	72	23		1,1	22,35	6,68	0,30	9400	11000	<b>2207**</b>	<b>2207K</b>
	80	18		1,1	19,88	6,56	0,30	7900	9400	<b>1208**</b>	<b>1208K</b>
45	90	23		1,5	29,87	9,81	0,45	7100	8400	<b>1308**</b>	<b>1308K</b>
	90	33		1,5	46,14	13,30	0,60	6700	7900	<b>2308**</b>	<b>2308K</b>
50	85	19		1,1	22,56	7,36	0,33	7500	8900	<b>1209**</b>	<b>1209K</b>
	85	23		1,1	24,00	8,10	0,37	7500	8900	<b>2209**</b>	<b>2209K</b>
	100	25		1,5	39,14	12,80	0,58	6300	7500	<b>1309**</b>	<b>1309K</b>
	100	36		1,5	55,41	16,50	0,75	6000	7100	<b>2309**</b>	<b>2309K</b>
55	90	20		1,1	23,38	8,10	0,37	7100	8400	<b>1210**</b>	<b>1210K</b>
	90	23		1,1	24,00	8,41	0,38	7100	8400	<b>2210**</b>	<b>2210K</b>
	110	27		2,0	44,60	14,10	0,64	5600	6700	<b>1310**</b>	<b>1310K</b>
60	100	21		1,5	27,60	10,00	0,45	6300	7500	<b>1211**</b>	<b>1211K</b>
	100	25		1,5	27,30	10,00	0,45	6300	7500	<b>2211**</b>	<b>2211K</b>
60	110	22		1,5	31,00	11,70	0,53	5600	6700	<b>1212**</b>	<b>1212K</b>
	110	28		1,5	35,23	12,60	0,57	5600	6700	<b>2212**</b>	<b>2212K</b>
	130	31		2,0	58,81	20,70	0,94	4700	5600	<b>1312**</b>	<b>1312K</b>
<b>** Bearings in the new standard NEW FORCE (see the catalogue NEW FORCE)</b>											

<sup>1)</sup> The dimension  $B_1$  indicates the bearing width measured over balls if they protrude from the bearing side faces

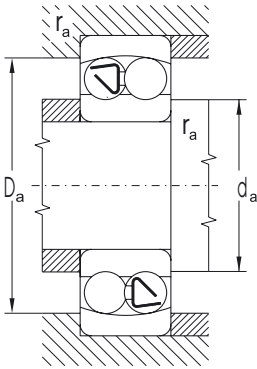

Abutment and Fillet Dimensions				Weight		Corresponding Adapter Sleeve	Factors			
d	d <sub>a min</sub>	D <sub>a max</sub>	r <sub>a max</sub>	K			e	Y <sub>1</sub>	Y <sub>2</sub>	Y <sub>0</sub>
mm				kg						
10	14	26	0,6	0,047			0,65	1,0	1,5	1,0
12	16	18	0,6	0,040			0,34	1,9	2,9	2,0
15	19	31	0,6	0,049			0,33	1,9	2,9	2,0
	19	31	0,6	0,060			0,49	1,3	2,0	1,3
17	21	36	0,6	0,073	0,071	H203	0,31	2,1	3,2	2,2
20	25	42	1,0	0,120	0,118	H204	0,27	2,3	3,6	2,4
25	30	47	1,0	0,141	0,138	H205	0,27	2,3	3,6	2,4
	30	47	1,0	0,163	0,158	H305	0,43	1,5	2,3	1,5
	32	55	1,0	0,264	0,259	H305	0,28	2,3	3,5	2,4
	31	55	1,0	0,335	0,327	H2305	0,47	1,3	2,1	1,4
30	35	57	1,0	0,220	0,216	H206	0,25	2,6	4,0	2,7
	35	57	1,0	0,260	0,254	H306	0,40	1,6	2,5	1,7
	36	65	1,0	0,387	0,381	H306	0,26	2,5	3,8	2,6
	36	65	1,0	0,500	0,489	H2306	0,44	1,4	2,2	1,5
35	42	65	1,0	0,323	0,317	H207	0,23	2,7	4,2	2,9
	42	65	1,0	0,403	0,396	H307	0,37	1,7	2,6	1,8
40	47	73	1,0	0,417	0,411	H208	0,22	2,9	4,4	3,0
	47	81	1,5	0,715	0,704	H308	0,24	2,6	4,1	2,7
	47	81	1,5	0,925	0,903	H2308	0,43	1,5	2,3	1,5
45	52	78	1,0	0,465	0,459	H209	0,21	3,0	4,6	3,1
	52	78	1,0	0,545	0,533	H309	0,31	2,1	3,2	2,2
	52	91	1,5	0,957	0,942	H309	0,25	2,5	3,9	2,7
	52	91	1,5	1,230	1,200	H2309	0,42	1,5	2,3	1,6
50	57	83	1,0	0,525	0,515	H210	0,20	3,1	4,9	3,3
	57	83	1,0	0,590	0,577	H310	0,29	2,2	3,4	2,3
	60	100	2,0	1,210	1,190	H310	0,24	2,7	4,1	2,8
55	62	91	1,5	0,705	0,693	H211	0,20	3,2	5,0	3,4
	62	91	1,5	0,810	0,792	H311	0,28	2,3	3,5	2,4
60	67	101	1,5	0,900	0,885	H212	0,19	3,4	5,3	3,6
	67	101	1,5	1,090	1,070	H312	0,28	2,3	3,5	2,4
	72	118	2,0	1,960	1,930	H312	0,23	2,8	4,3	2,9

# Double Row Self-Aligning Ball Bearings

d = 65 to 150 mm

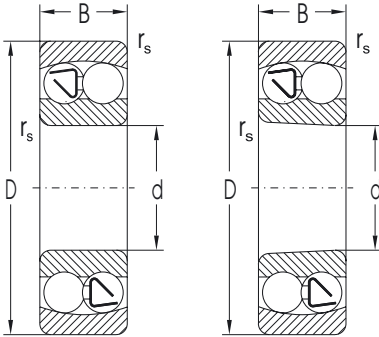

K

Dimensions					Basic Load Dynamic $C_r$	Rating Static $C_{or}$	Fatigue load limit $P_u$	Limiting Speed for Lubrication with		Bearing Designation	
d	D	B	$B_1^{1)}$	$r_s$				Grease	Oil	with Cylindrical Bore	with Tapered Bore
mm					kN		kN	min <sup>-1</sup>			
65	120	23		1,5	31,93	12,3	0,56	5300	6300	1213**	1213K
	120	31		1,5	44,91	16,5	0,75	5300	6300	2213**	2213K
70	140	48		2,1	98,88	32,4	1,47	4000	4800	2313**	2313K
	125	31		1,5	45,22	17,1	0,78	5000	6000	2214**	2214K
75	150	51		2,1	112,27	37,6	1,63	3800	4500	2314**	2314K
	130	25		1,5	40,07	15,5	0,70	4700	5600	1215**	1215K
	130	31		1,5	45,53	17,8	0,80	4700	5600	2215**	2215K
80	160	37		2,1	81,68	29,9	1,25	3800	4500	1315**	1315K
	160	55		2,1	126,69	43,0	1,80	3500	4200	2315**	2315K
	140	26		2,0	40,99	16,8	0,73	4500	5300	1216**	1216K
85	140	33		2,0	50,47	20,0	0,87	4500	5300	2216**	2216K
	150	28		2,0	50,57	20,3	0,85	4000	4700	1217**	1217K
	180	41		3,0	100,63	37,6	1,48	3300	4000	1317**	1317K
90	180	60		3,0	144,20	51,1	2,02	3200	3800	2317**	2317K
	160	30		2,0	58,61	23,3	0,95	3800	4500	1218**	1218K
	160	40		2,0	72,41	28,7	1,17	3800	4500	2218**	2218K
95	190	64		3,0	157,59	57,3	2,20	3000	3500	2318**	2318K
	170	32		2,1	65,61	27,1	1,07	3500	4200	1219**	1219K
	170	43		2,1	85,70	34,1	1,35	3500	4200	2219**	2219K
	200	45	48	3,0	135,96	51,1	1,91	3000	3500	1319**	1319K
100	200	67		3,0	169,95	64,3	2,41	2800	3300	2319**	2319K
	180	34		2,1	71,07	29,3	1,13	3300	4000	1220**	1220K
	180	46		2,1	96,92	40,6	1,56	3300	4000	2220**	2220K
	215	47	52	3,0	147,29	58,4	2,12	2800	3300	1320**	1320K
110	215	73		3,0	197,76	77,9	2,82	2700	3200	2320**	2320K
	200	38		2,1	90,54	38,3	1,40	3000	3500	1222**	1222K
	200	53		2,1	123,60	52,1	1,90	3000	3500	2222**	2222K
	240	50	55	3,0	167,89	70,8	2,43	2700	3200	1322**	1322K
120	240	80		3,0	223,51	94,4	3,24	2500	3000	2322**	2322K
	215	42	45	2,1	119,00	52,1	1,83	2800	3300	1224	
	260	55	62	3,0	196,00	90,9	3,00	2500	3000	1324	
130	230	46	48	3,0	129,78	59,6	2,02	2700	3200	1226**	1226K
140	250	50	54	3,0	163,77	72,2	2,35	2500	3000	1228**	1228K
150	270	54	56	3,0	176,13	85,8	2,69	2400	2800	1230**	1230K

\*\* Bearings in the new standard NEW FORCE

<sup>1)</sup> The dimension  $B_1$  indicates the bearing width measured over balls if they protrude from the bearing side faces

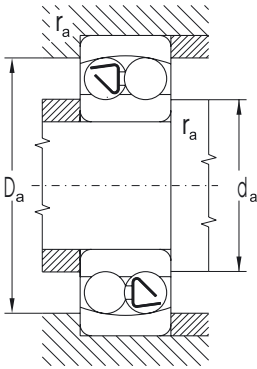

Abutment and Fillet Dimensions				Weight		Corresponding Adapter Sleeve	Factors			
d	d <sub>a min</sub>	D <sub>a max</sub>	r <sub>a max</sub>	-	K		e	Y <sub>1</sub>	Y <sub>2</sub>	Y <sub>0</sub>
mm				kg						
65	72	111	1,5	1,15	1,13	H213	0,17	3,7	5,7	3,9
	72	111	1,5	1,46	1,43	H313	0,28	2,2	3,5	2,3
	76	128	2,0	3,28	3,20	H2313	0,38	1,6	2,5	1,7
70	77	116	1,5	1,52	1,49	H314	0,27	2,4	3,7	2,5
	81	138	2,0	3,9	3,79	H2314	0,38	1,7	2,6	1,8
75	82	121	1,5	1,36	1,34	H215	0,18	3,6	5,6	3,8
	82	121	1,5	1,62	1,58	H315	0,25	2,5	3,9	2,6
	86	148	2,0	3,56	3,51	H315	0,22	2,8	4,4	3,0
80	86	148	2,0	4,72	4,61	H2315	0,38	1,7	2,6	1,7
	90	130	2,0	1,67	1,64	H216	0,16	3,9	6,1	4,1
85	90	130	2,0	2,01	1,97	H316	0,25	2,5	3,9	2,6
	95	140	2,0	2,07	2,04	H217	0,17	3,7	5,7	3,9
	98	166	2,5	4,98	4,91	H317	0,22	2,9	4,5	3,0
90	98	166	2,5	6,71	6,55	H2317	0,37	1,7	2,7	1,8
	100	150	2,0	2,52	2,48	H218	0,17	3,8	5,8	3,9
	100	150	2,0	3,20	3,13	H318	0,27	2,4	3,6	2,5
95	103	176	2,5	7,96	7,77	H2318	0,38	1,7	2,6	1,8
	107	158	2,0	3,10	3,05	H219	0,17	3,7	5,7	3,9
	107	158	2,0	3,95	3,85	H319	0,27	2,4	3,6	2,5
	109	186	2,5	6,69	6,59	H319	0,23	2,8	4,3	2,9
100	109	186	2,5	9,21	8,99	H2319	0,38	1,7	2,6	1,8
	112	168	2,0	3,70	3,64	H220	0,17	3,6	5,6	3,8
	112	168	2,0	4,72	4,61	H320	0,27	2,4	3,6	2,5
	113	201	2,5	8,30	8,19	H320	0,24	2,7	4,1	2,8
110	113	201	2,5	11,70	11,40	H2320	0,38	1,7	2,6	1,7
	122	188	2,0	5,15	5,07	H222	0,17	3,6	5,6	3,8
	122	188	2,0	6,84	6,68	H322	0,28	2,3	3,5	2,4
	124	226	2,5	11,80	11,70	H322	0,22	2,8	4,4	3,0
120	124	226	2,5	17,30	16,90	H2322	0,37	1,7	2,7	1,8
	132	203	2,0	6,75			0,19	3,3	5,1	3,4
	134	246	2,5	15,50			0,24	2,7	4,1	2,8
130	144	216	2,5	8,30	8,10		0,19	3,3	5,0	3,4
140	154	236	2,5	10,90	10,55		0,20	3,1	4,8	3,3
150	164	256	2,5	13,80	13,50		0,19	3,2	5,0	3,4

# Single Row Cylindrical Roller Bearings

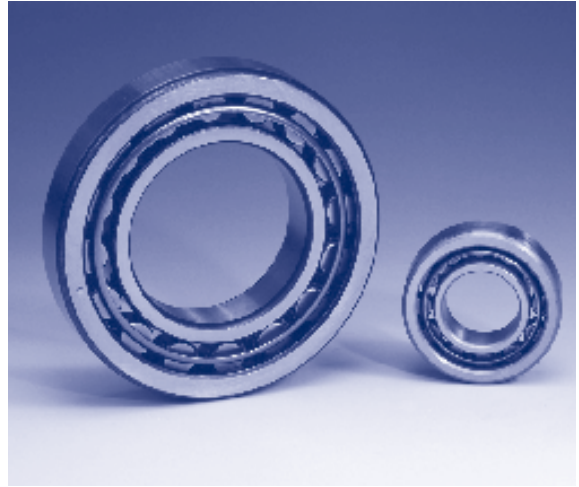

These bearings are separable and are produced in several designs.

Design NU has cylindrical rollers guided between guiding ribs of the outer ring, the design N between guiding ribs of the inner ring. Both designs enable mutual bearing rings displacement in both directions.

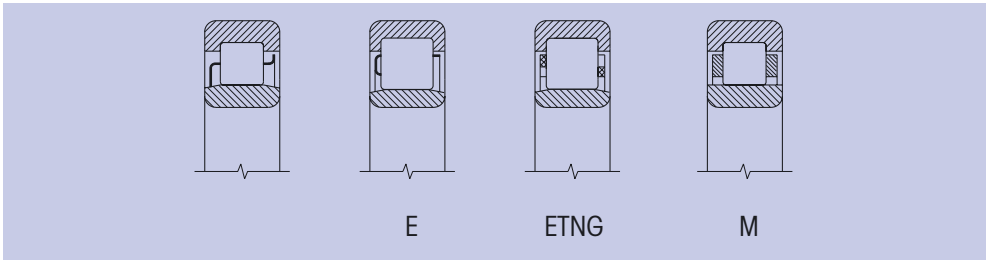

Design NJ has two guiding ribs on the outer ring and one on the inner ring, which enables to carry the axial forces in one direction.

NUP design has a loose inner rib creating the second guiding rib of the inner ring and this enables the bearing to carry limited axial forces in both directions. Axial guiding in both directions can be achieved by means of angle rings HJ for bearings in NJ design and in one direction in NU design.

Single row cylindrical roller bearings have in comparison with single row ball bearings of the same size higher basic load rating and are suitable for arrangements with high radial load, high rotational speed and when light fitting of both rings is desirable.

Basic dynamic load rating of bearings with internal design E is in average higher by 30% as that one for bearings with basic internal design.

## Boundary Dimensions

Boundary dimensions comply with the standard ISO 15 and are shown in the dimension tables of this publication.

## Designation

Bearing designation in standard design is in the dimension tables of this publication.

Difference from standard design is designated by additional symbols (section 2.2).

## Cages

Bearings in standard design have cage according to dimension tables. Material symbol and symbol of the cage design are not indicated by bearings with pressed steel cage. For special arrangements bearings with plastic or brass cages which can be coated with silver are produced. This delivery should be discussed in advance.

## Tolerance

Bearings are commonly produced in normal tolerance class P0 which is not indicated. Bearings for more demanding arrangements are delivered in tolerance classes P6, P5 and P4.

Bearing Type	Bearings with Pressed Steel Cage	Bearings with Reinforced Solid Plastic Cage	Bearings with Machined Brass or Steel Cage
	Bearing Size		
NU/NUP29	-	-	/800 to /1800
NU10	-	-	80 to 80
NU/NJ/NUP/N2	05 to 28	-	48
NU/NJ/NUP/N2E	09, 15	04 to 24	22 to 40
NU/NJ/NUP22	05 to 07, 10, 11, 13, 14, 19	-	36, 80
NU/NJ/NUP22E	09, 15, 17	40 to 20	22 to 30
NU/NJ/NUP/N3	05 to 24	-	26 to 30
NU/NJ/NUP/N3E	-	04 to 17	18 to 30
NU/NJ/NUP23	07, 12, 13, 15	-	-
NU/NJ/NUP23E	09	04 to 17	07, 08, 10, 14 18 to 30
NU/NJ/NUP/N4	06 to 12, 14 to 16	-	13, 17 to 24

Limiting deviation values of dimension and running accuracy are shown in tables 10 and 11 and comply with standards ISO 199 and ISO 492.

## Radial Clearance

Commonly produced bearings have normal radial clearance which is not indicated. For special arrangements bearings with smaller clearance C2 or greater radial clearance C3, C4 and C5 are delivered. Radial clearance values comply with the standard ISO 5753 and are shown in table 24.

## Vibration Level

Commonly produced single row cylindrical roller bearings have normal vibration level checked by the producer. Bearings in tolerance class P5 and P4 have vibration level C6. For special arrangements bearings with reduced vibration level C6 are manufactured.

## Bearings with Angle Rings

Angle rings - type HJ10, HJ2, HJ2E, HJ3, HJ3E and HJ4 can be used for bearings in NJ and NU designs.

Examples of bearing designation :

NJ10 + HJ10 = NH10      NU10 + HJ10 = NUJ10

NJ2 + HJ2 = NH2      NU2 + HJ2 = NUJ2

NJ3 + HJ3 = NH3      NU3 + HJ3 = NUJ3

NJ4 + HJ4 = NH4      NU4 + HJ4 = NUJ4

Pictures of individual basic designs and combinations are in the dimension tables of the publication.

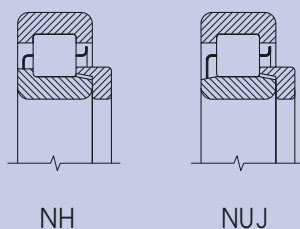

NH

NUJ

## Bearings without Inner Ring

For arrangements with limited space for bearing mounting, single row cylindrical roller bearings without inner ring designated R NU are delivered. The inner bearing ring raceway is created directly by the hardened and ground journal.

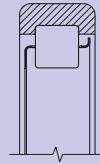

R NU

Dimension tolerance on the journal is usually “g5” for normal radial clearance, “f5” for greater radial clearance and “h5” for smaller radial clearance. Ovality and cylindricity deviations of the “raceway” on this journal must not be greater than deviations for tolerance class IT3. Surface roughness for this surface should be  $R_a = 0.2$  and for less demanding arrangements  $R_a = 0.4$ .

Basic load rating  $C_r$  and  $C_{or}$  values shown in the dimension tables, are valid for bearings R NU if the journal surface hardness will be in the range 59 to 65 HRC. With decreasing hardness value also load rating values  $C_r$  decrease. It must be multiplied by the factor  $f_h$  from following table. Minimum depth of journal hardening after grinding depends on the cylindrical roller diameter and load magnitude and should be 1 to 3 mm.

Hardness HRC	58	56	54	51	48	45	40	35	30
Factor $f_h$	0.9	0.8	0.7	0.6	0.5	0.4	0.3	0.25	0.2

## Misalignment

Mutual bearing ring misalignment of single row cylindrical roller bearings is very small. Permissible misalignment values are in the table.

Bearing Type	Load	
	small ( $F_r < 0,1C_{or}$ )	great ( $F_r \geq 0,1C_{or}$ )
NU10, NU2, NU3, NU4	2' to 3'	5' to 7'
NU29, NU22, NU23	1' to 3'	3' to 4'
Designs NJ, NUP, N <sup>1)</sup> of all dimension series	1' to 2'	3' to 4'

<sup>1)</sup> Smaller values of the number pair are valid for bearings of width series 2 and higher

## Radial Equivalent Dynamic Load

$$P_r = F_r$$

[kN]



## Axial Dynamic Load Rating

Bearings with ribs on both rings can carry, besides the radial load, also a limited axial load. Because permissible bearing load in axial direction depends on many factors, which cannot be expressed only by a simple calculation, the following relations have only an informative character.

The axial load in this case is not limited by the material fatigue but by the carrying capacity of the lubrication film on the contact surface between the cylindrical roller face and guiding rib and lubrication conditions and operating temperature and cooling possibilities of the bearing. At common working conditions when the difference of the bearing and environment temperature does not exceed 60°C, by slight heat transfer ( $0.5\text{mWmm}^{-2}\text{ }^{\circ}\text{C}^{-1}$ ), by viscosity relation 1.5 (section 4.2.1) it is possible to calculate maximum permissible axial load with sufficient accuracy from equation:

$$F_{a\text{ max}} = \frac{0.5 C_{or} \times 10^4}{n (d + D)} - 0.05 F_r \quad [\text{kN}]$$

- for oil lubrication

$$F_{a\text{ max}} = \frac{0.35 C_{or} \times 10^4}{n (d + D)} - 0.03 F_r \quad [\text{kN}]$$

- for grease lubrication

$F_{a\text{ max}}$	- maximum permissible axial load	[kN]
$C_{or}$	- radial basic static load rating	[kN]
$F_r$	- radial bearing load	[kN]
$n$	- rotational speed	[min <sup>-1</sup> ]
$d$	- bearing bore diameter	[mm]
$D$	- bearing outside diameter	[mm]

Values  $F_{a\text{ max}}$  calculated according to the above introduced equations are valid under assuming of continuously acting axial force. For intermittent or impact load the permissible axial load can be two or three times greater in comparison with calculated value. For reliable bearing function it is important that ratio  $F_a/F_r \leq 0.4$ .

## Radial Equivalent Static Load

$$P_{or} = F_r \quad [\text{kN}]$$



# Single Row Cylindrical Roller Bearings

d = 20 to 40 mm

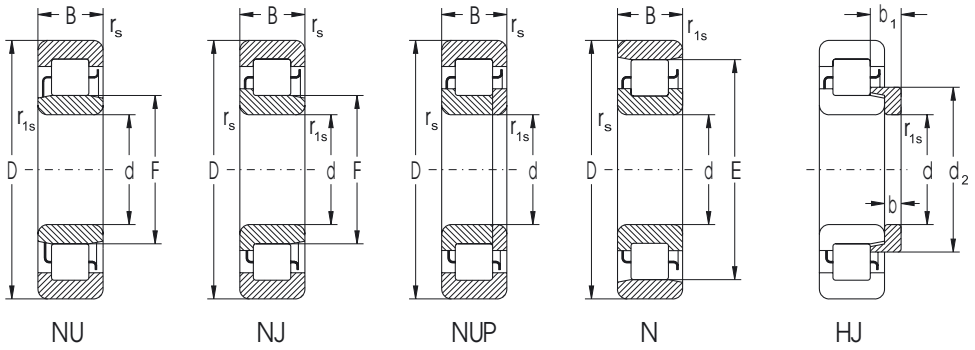

Dimensions											Bearing Designation				Angle
d	D	B	r <sub>s</sub> min	r <sub>1s</sub> min	F	E	d <sub>2</sub> max	b	b <sub>1</sub>	s <sup>1)</sup>	NU	NJ	NUP	N	HJ
mm															
20	47	14.00	1.0	0.6	27.0	40.0	30.0	3	6.75	1.4	<b>NU204</b>	<b>NJ204</b>	<b>NUP204</b>	<b>N204</b>	<b>HJ204</b>
25	52	15.00	1.0	0.6	32.0	45.0	35.0	3	7.25	1.5	<b>NU205</b>	<b>NJ205</b>	<b>NUP205</b>	<b>N205</b>	<b>HJ205</b>
	52	15.00	1.0	0.6	31.5		34.9	3	6.00	1.4	<b>NU205E</b>	<b>NJ205E</b>	<b>NUP205E</b>		<b>HJ205E</b>
	52	15.00	1.0	0.6	31.5	46.5	34.9	3	6.00	1.4	<b>NU205ETNG</b>	<b>NJ205ETNG</b>	<b>NUP205ETNG</b>	<b>N205ETNGHJ205E</b>	
	52	18.00	1.0	0.6	32.0					1.6	<b>NU2205</b>	<b>NJ2205</b>	<b>NUP2205</b>		
	62	17.00	1.1	1.1	35.0	53.0	39.3	4	8.00	1.4	<b>NU305</b>	<b>NJ305</b>	<b>NUP305</b>	<b>N305</b>	<b>HJ305</b>
	62	17.00	1.1	1.1	34.0		38.3	4	7.00	1.4	<b>NU305EMAS</b>	<b>NJ305EMAS</b>	<b>NUP305EMAS</b>		<b>HJ305E</b>
	62	17.00	1.1	1.1	34.0	54.0	38.3	4	7.00	1.4	<b>NU305ETNG</b>	<b>NJ305ETNG</b>	<b>NUP305ETNG</b>	<b>N305ETNGHJ305E</b>	
	80	21.00	1.5	1.5	38.8					1.4	<b>NU405</b>	<b>NJ405</b>			
30	62	16.00	1.0	0.6	38.5	53.5	42.2	4	8.25	1.5	<b>NU206</b>	<b>NJ206</b>	<b>NUP206</b>	<b>N206</b>	<b>HJ206</b>
	62	16.00	1.0	0.6	37.5	55.5	41.4	4	7.00	1.4	<b>NU206ETNG</b>	<b>NJ206ETNG</b>	<b>NUP206ETNG</b>	<b>N206ETNGHJ206E</b>	
	62	20.00	1.0	0.6	38.5					1.6	<b>NU2206</b>	<b>NJ2206</b>	<b>NUP2206</b>		
	72	19.00	1.1	1.1	42.0	62.0	46.6	5	9.50	1.4	<b>NU306</b>	<b>NJ306</b>	<b>NUP306</b>	<b>N306</b>	<b>HJ306</b>
	72	19.00	1.1	1.1	40.5		45.1	5	8.50	1.4	<b>NU306E</b>	<b>NJ306E</b>	<b>NUP306E</b>		<b>HJ306E</b>
	72	19.00	1.1	1.1	40.5	62.5	45.1	5	8.50	1.4	<b>NU306ETNG</b>	<b>NJ306ETNG</b>	<b>NUP306ETNG</b>	<b>N306ETNGHJ306E</b>	
	90	23.00	1.5	1.5	45.0		51.4	7	11.50	1.5	<b>NU406</b>	<b>NJ406</b>	<b>NUP406</b>		<b>HJ406</b>
	65	21.00	1.0	0.6	38.5					1.6	<b>NU22/32ETNG</b>				
35	72	17.00	1.1	0.6	43.8	61.8	48.1	4	8.00	1.5	<b>NU207</b>	<b>NJ207</b>	<b>NUP207</b>	<b>N207</b>	<b>HJ207</b>
	72	17.00	1.1	0.6	44.0		48.3	4	7.00	1.4	<b>NU207E</b>	<b>NJ207E</b>	<b>NUP207E</b>		<b>HJ207E</b>
	72	17.00	1.1	0.6	44.0	64.0	48.3	4	7.00	1.4	<b>NU207ETNG</b>	<b>NJ207ETNG</b>	<b>NUP207ETNG</b>	<b>N207ETNGHJ207E</b>	
	72	23.00	1.1	0.6	43.8					1.6	<b>NU2207</b>	<b>NJ2207</b>	<b>NUP2207</b>		
	72	23.00	1.1	0.6	44.0					1.6	<b>NU2207ETNG</b>	<b>NJ2207ETNG</b>	<b>NUP2207ETNG</b>		
	80	21.00	1.5	1.1	46.2	68.2	51.2	6	11.00	1.4	<b>NU307</b>	<b>NJ307</b>	<b>NUP307</b>	<b>N307</b>	<b>HJ307</b>
	80	21.00	1.5	1.1	46.2		51.2	6	9.50	1.4	<b>NU307E</b>	<b>NJ307E</b>	<b>NUP307E</b>		<b>HJ307E</b>
	80	31.00	1.5	1.1	46.2					2.7	<b>NU2307EMAS</b>		<b>NUP2307EMAS</b>	<b>NUP2307EMAS</b>	
100	25.00	1.5	1.5	53.0	83.0	59.9	8	13.00	1.5	<b>NU407</b>	<b>NJ407</b>	<b>NUP407</b>	<b>N407</b>	<b>HJ407</b>	
40	80	18.00	1.1	1.1	50.0	70.0	54.6	5	9.00	1.5	<b>NU208</b>	<b>NJ208</b>	<b>NUP208</b>	<b>N208</b>	<b>HJ208</b>
	80	18.00	1.1	1.1	49.5		54.1	5	8.50	1.4	<b>NU208E</b>	<b>NJ208E</b>	<b>NUP208E</b>		<b>HJ208E</b>
	80	23.00	1.1	1.1	50.0					1.6	<b>NU2208</b>	<b>NJ2208</b>	<b>NUP2208</b>		
	80	30.16	1.0	1.5	49.3					3	<b>NU5208M</b>				
	90	23.00	1.5	1.5	53.5	77.5	59.0	7	12.50	1.4	<b>NU308</b>	<b>NJ308</b>	<b>NUP308</b>	<b>N308</b>	<b>HJ308</b>
	90	23.00	1.5	1.5	52.0		57.7	7	11.00	1.4	<b>NU308E</b>	<b>NJ308E</b>	<b>NUP308E</b>		<b>HJ308E</b>
	90	23.00	1.5	1.5	52.0	80.0	57.7	7	11.00	1.4	<b>NU308ETNG</b>	<b>NJ308ETNG</b>	<b>NUP308ETNG</b>	<b>N308ETNGHJ308E</b>	
	90	33.00	1.5	1.5	52.0					2.9	<b>NU2308EMAS</b>		<b>NUP2308EMAS</b>	<b>NUP2308EMAS</b>	
	110	27.00	2.0	2.0	58.0	92.0	65.8	8	13.00	1.5	<b>NU408</b>	<b>NJ408</b>	<b>NUP408</b>	<b>N408</b>	<b>HJ408</b>

<sup>1)</sup> Permissible axial displacement out of central position

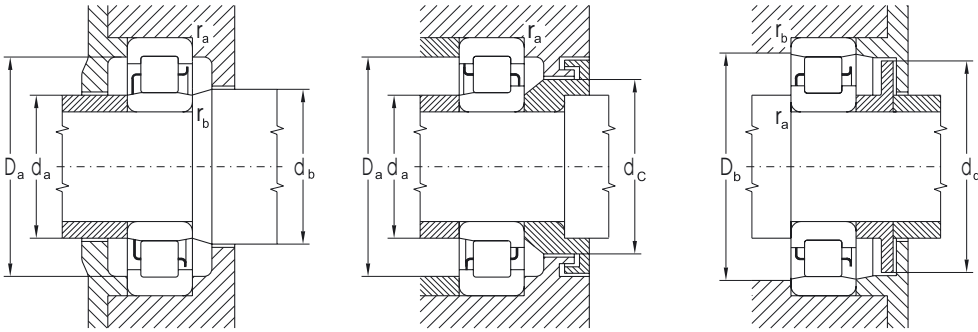

Basic Load Rating		Fatigue load limit $P_u$	Limiting Speed for Lubrication with		Abutment and Fillet Dimensions										Weight	
Dynamic $C_r$	Static $C_{or}$		Grease	Oil	d	$d_{a\ min}$	$d_{a\ max}$	$d_{b\ min}$	$d_{c\ min}$	$d_{d\ max}$	$D_{a\ max}$	$D_{b\ min}$	$r_{a\ max}$	$r_{b\ max}$	Bearing	Angle Ring
kN		kN	$\text{min}^{-1}$		mm										kg	
13.9	10.2	1.24	14000	17000	20	25	25.5	29	32	39	42	42	1.0	0.6	0.11	0.01
15.8	12.6	1.54	12600	15000	25	30	30.5	34	37	43	47	47	1.0	0.6	0.13	0.02
29.3	25.6	3.12	12600	15000	30	30.0	34	37	-	47	-	-	1.0	0.6	0.13	0.02
29.3	25.6	3.12	12600	15000	30	30.0	34	37	44	47	47	1.0	0.6	0.13	0.02	
22.4	19.6	2.39	12600	15000	30	30.5	34	37	-	47	-	1.0	0.6	0.16		
27.6	21.5	2.62	10000	12000	31	33.0	37	40	51	55	55	1.0	1.0	0.24	0.03	
43.0	36.2	4.41	10000	12000	31	32.0	37	40	-	55	-	1.0	1.0	0.26	0.03	
43.0	36.2	4.41	10000	12000	31	32.0	36	39	52	55	55	1.0	1.0	0.24	0.03	
43.8	34.1	4.16	8400	10000	32	38.0	39	40	-	73	-	1.0	1.0	0.57		
21.5	17.8	2.17	10600	12600	30	35	37.0	40	44	52	57	56	1.0	0.6	0.20	0.03
39.1	35.5	4.33	10600	12600	35	37.0	40	43	54	57	57	1.0	0.6	0.20	0.03	
31.6	29.3	3.57	10600	12600	35	37.0	40	44	-	57	-	1.0	0.6	0.26		
36.2	31.0	3.78	8900	10600	36	39.0	44	48	60	65	64	1.0	1.0	0.36	0.04	
53.1	46.4	5.66	8400	10000	36	37.5	43	47	-	65	-	1.0	1.0	0.36	0.04	
53.1	46.4	5.66	8400	10000	36	37.5	43	47	60	65	64	1.0	1.0	0.36	0.04	
59.6	48.2	5.88	7100	8400	39	41.0	47	53	-	80	-	1.5	1.5	0.75	0.08	
51.1	50.1	6.11	10000	12000	32	35	37.0	39	43	-	60	-	1.0	1.0	0.31	
31.6	27.1	3.30	9400	11000	35	42	42.0	46	50	60	65	64	1.0	0.6	0.29	0.04
51.1	48.2	5.88	8900	10600	42	42.0	46	50	62	65	65	1.0	0.6	0.29	0.04	
51.1	48.2	5.88	8900	10600	42	42.0	46	50	62	65	65	1.0	0.6	0.29	0.04	
48.2	47.3	5.77	9400	11000	42	42.0	46	50	-	65	-	1.0	0.6	0.40		
64.3	64.3	7.84	8900	10600	42	42.0	46	50	-	65	-	1.0	0.6	0.39		
43.0	36.2	4.41	7900	9400	42	44.0	48	53	66	71	71	1.5	1.0	0.48	0.06	
66.8	61.9	7.55	7500	8900	42	44.0	48	53	-	71	-	1.5	1.0	0.47	0.06	
92.6	92.6	11.29	7100	8400	42	44.0	48	53	-	71	-	1.5	1.0	0.75		
75.0	64.3	7.84	6300	7500	44	52.0	55	62	81	90	86	1.5	1.5	1.00	0.13	
42.2	37.6	4.59	7900	9400	40	47	48.0	52	56	68	73	72	1.0	1.0	0.37	0.05
54.1	50.1	6.11	7900	9400	47	47.0	51	56	-	73	-	1.0	1.0	0.38	0.05	
57.3	56.2	6.85	7900	9400	47	48.0	52	56	-	73	-	1.0	1.0	0.74		
57.0	98.1	11.96	7500	8900	48	-	51.5	-	72	-	72	-	1.5	1.5	0.74	
55.2	48.2	5.88	7100	8400	47	51.0	55	61	75	81	81	1.5	1.5	0.66	0.09	
84.1	77.9	9.50	6700	7900	47	50.0	54	60	-	81	-	1.5	1.5	0.67	0.08	
84.1	77.9	9.50	6700	7900	47	50.0	54	60	77	81	81	1.5	1.5	0.83	0.08	
119.0	123.0	15.00	6300	7500	47	50.0	54	60	-	81	-	1.5	1.5	1.00		
92.6	79.4	9.68	5600	6700	50	55.0	60	68	90	97	95	2.0	2.0	1.30	0.14	

# Single Row Cylindrical Roller Bearings

d = 45 to 60 mm

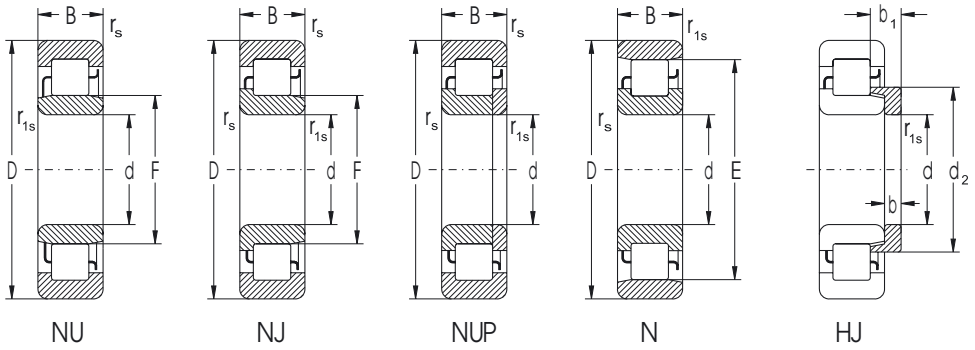

Dimensions											Bearing Designation				Angle Ring HJ	
d	D	B	r <sub>s</sub>	r <sub>1s</sub>	F	E	d <sub>2</sub>	b	b <sub>1</sub>	s <sup>1)</sup>	NU	NJ	NUP	N	HJ	
			min	min												
mm																
45	85	19.00	1.1	1.1	55.00	75.0	59.6	5.0	9.50	1.5	NU209	NJ209	NUP209	N209	HJ209	
	85	19.00	1.1	1.1	54.50		59.1	5.0	8.50	1.4	NU209E	NJ209E	NUP209E		HJ209E	
	85	19.00	1.1	1.1	54.50	76.5	59.1	5.0	8.50	1.4	NU209ETNG	NJ209ETNG	NUP209ETNG	N209ETNG	HJ209E	
	85	23.00	1.1	1.1	54.50					1.6	NU2209E	NJ2209E	NUP2209E			
	85	23.00	1.1	1.1	54.50					1.6	NU2209ETNG	NJ2209ETNG	NUP2209ETNG			
	85	30.16	1.0	1.5	55.52					4.0	NU5209M					
	100	25.00	1.5	1.5	58.50	86.5	65.0	7.0	12.50	1.4	NU309	NJ309	NUP309	N309	HJ309	
	100	25.00	1.5	1.5	58.50		64.6	7.0	11.50	1.4	NU309E	NJ309E	NUP309E		HJ309E	
	100	36.00	1.5	1.5	58.50					2.9	NU2309E	NJ2309E	NUP2309E			
	120	29.00	2.0	2.0	64.50	100.5	72.8	8.0	13.50	1.5	NU409	NJ409	NUP409	N409	HJ409	
	50	90	20.00	1.1	1.1	59.50		64.6	5.0	9.00	1.6	NU210E	NJ210E	NUP210E		HJ210E
		90	23.00	1.1	1.1	60.40					1.6	NU2210	NJ2210	NUP2210		
90		23.00	1.1	1.1	59.50					1.6	NU2210E	NJ2210E	NUP2210E			
90		30.16	1.0	1.5	60.46					4.5	NU5210M					
110		27.00	2.0	2.0	65.00	95.0	71.9	8.0	14.00	1.5	NU310	NJ310	NUP310	N310	HJ310	
110		27.00	2.0	2.0	65.00	97.0	71.4	8.0	13.00	1.5	NU310ETNG	NJ310ETNG	NUP310ETNG	N310ETNG	HJ310E	
110		40.00	2.0	2.0	65.00					3.0	NU2310	NJ2310	NUP2310			
110		40.00	2.0	2.0	65.00					3.0	NU2310EMAS	NJ2310EMAS	NUP2310EMAS			
130		31.00	2.1	2.1	70.80	110.8	80.0	9.0	14.50	2.0	NU410	NJ410	NUP410	N410	HJ410	
55		100	21.00	1.5	1.1	66.50	88.5	71.5	6.0	11.00	1.6	NU211	NJ211	NUP211	N211	HJ211
		100	21.00	1.5	1.1	66.00	71.0	6.0	9.50	1.6	NU211E	NJ211E	NUP211E		HJ211E	
		100	25.00	1.5	1.1	66.50					1.6	NU2211	NJ2211	NUP2211		
	100	33.34	1.5	2.1	66.90					4.5	NU5211M					
	120	29.00	2.0	2.0	70.50	104.5	78.4	9.0	15.00	1.5	NU311	NJ311	NUP311	N311	HJ311	
	120	29.00	2.0	2.0	70.50		77.7	9.0	14.00	1.5	NU311E	NJ311E	NUP311E		HJ311E	
	140	33.00	2.1	2.1	77.20	117.2	86.4	10.0	16.60	3.0	NU411	NJ411	NUP411	N411	HJ411	
	60	110	22.00	1.5	1.5	73.50	97.5	79.0	6.0	11.00	1.6	NU212	NJ212	NUP212	N212	HJ212
		110	28.00	1.5	1.5	73.50					1.6	NU2212	NJ2212	NUP2212		
		110	36.50	1.5	2.0	72.38					4.5	NU5212M				
		130	31.00	2.1	2.1	77.00	113.0	85.3	9.0	15.50	1.5	NU312	NJ312	NUP312	N312	HJ312
		130	46.00	2.1	2.1	77.00					4.5	NU2312	NJ2312	NUP2312		
150		35.00	2.1	2.1	83.00	127.0	93.1	10.0	16.50	2.0	NU412	NJ412	NUP412	N412	HJ412	

<sup>1)</sup> Permissible axial displacement out of central position

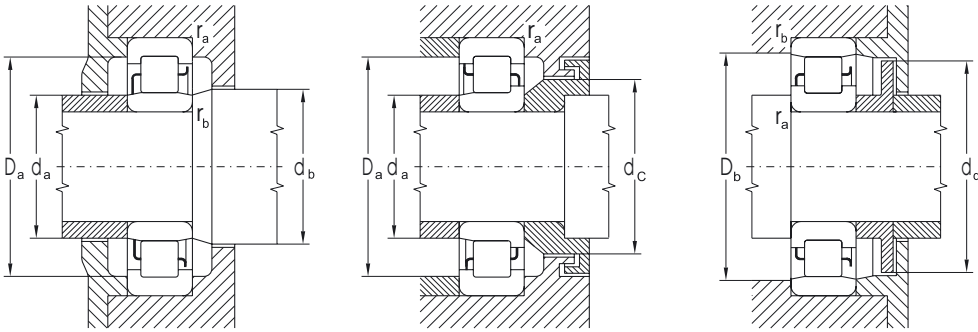

Basic Load Rating		Fatigue load limit $P_u$	Limiting Speed for Lubrication with		Abutment and Fillet Dimensions								Weight			
Dynamic $C_r$	Static $C_{or}$		Grease	Oil	d	$d_a$ min	$d_a$ max	$d_b$ min	$d_c$ min	$d_c$ max	$D_a$ max	$D_b$ min	$r_a$ max	$r_b$ max	Bearing	Angle Ring
kN		kN	min <sup>-1</sup>		mm								kg			
43.8	41.1	5.01	7500	8900	45	52	53	57	61	74	78	78	1.0	1.0	0.43	0.05
61.9	60.7	7.40	7500	8900		52	53	57	61	-	78	-	1.0	1.0	0.45	0.05
61.9	60.7	7.40	7500	8900		52	53	57	61	74	78	78	1.0	1.0	0.43	0.05
76.4	79.4	9.68	7100	8400		52	53	57	61	-	78	-	1.0	1.0	0.55	
76.4	79.4	9.68	7100	8400		53	53	57	61	-	76	-	1.5	1.0	0.52	
89.1	117.7	14.35	6700	7900		53	-	57	-	-	76	-	1.5	1.0	0.80	
70.8	61.9	7.55	6300	7500		52	56	60	66	84	91	90	1.5	1.5	0.87	0.10
102.0	98.0	11.95	6000	7100		52	56	60	66	-	91	-	1.5	1.5	0.89	0.10
139.0	147.0	17.93	5600	6700		52	56	60	66	-	91	-	1.5	1.5	1.36	
104.0	90.9	11.09	5300	6300		55	62.7	66	75	99	107	103	2.0	2.0	1.65	0.18
64.3	65.6	8.00	6700	7900	50	57	57	61	66	-	83	-	1.0	1.0	0.49	0.06
63.1	66.8	8.15	7100	8400		57	58	62	66	-	83	-	1.0	1.0	0.58	
84.1	90.9	11.09	6700	7900		57	57	61	66	-	83	-	1.0	1.0	0.59	
92.6	128.0	15.61	6300	7500		58	-	62	-	-	81	-	1.5	1.0	0.88	
87.4	79.4	9.68	5600	6700		60	63	67	74	93	100	99	2.0	2.0	1.15	0.15
117.0	114.0	13.90	5300	6300		60	63	67	74	95	100	100	2.0	2.0	1.13	0.14
123.0	126.0	15.37	5600	6700		60	63	67	74	-	100	-	2.0	2.0	0.17	
168.0	178.0	21.71	5000	6000		60	63	67	74	-	100	-	2.0	2.0	1.83	
139.0	114.0	13.90	4700	5600		63	68	73	82	109	116	114	2.0	2.0	2.00	0.23
56.2	56.2	6.85	6300	7500	55	62	65	68	73	86	91	91	1.5	1.0	0.64	0.08
85.8	90.9	11.09	6300	7500		62	64.5	68	73	-	91	-	1.5	1.0	0.66	0.08
76.4	82.5	10.06	6300	7500		62	65	68	73	-	91	-	1.5	1.0	0.78	
119.0	171.0	20.85	5600	6700		64	-	69	-	-	90	-	2.0	1.5	1.20	
108.0	100.0	12.20	5300	6300		65	67	72	80	102	110	108	2.0	2.0	1.45	0.19
136.0	128.0	15.61	4700	5600		65	67	72	80	-	110	-	2.0	2.0	1.38	0.18
139.0	128.0	15.61	4500	5300		68	71	79	88	115	126	120	2.0	2.0	2.50	0.30
66.8	68.1	8.30	5600	6700	60	67	71	75	80	95	101	101	1.5	1.5	0.82	0.11
98.1	112.0	13.66	5600	6700		69	69.5	74	79	-	101	-	1.5	1.5	1.05	
150.0	211.0	25.73	5300	6300		69	-	74	-	-	99	-	2.0	1.5	1.59	
121.0	114.0	13.90	4700	5600		72	75	79	87	110	118	117	2.0	2.0	1.85	0.22
168.0	174.0	21.22	4700	5600		72	75	79	87	-	118	-	2.0	2.0	2.70	
168.0	158.0	18.99	4200	5000		73	77	85	95	124	136	130	2.0	2.0	3.00	0.34

# Single Row Cylindrical Roller Bearings

d = 65 to 80 mm

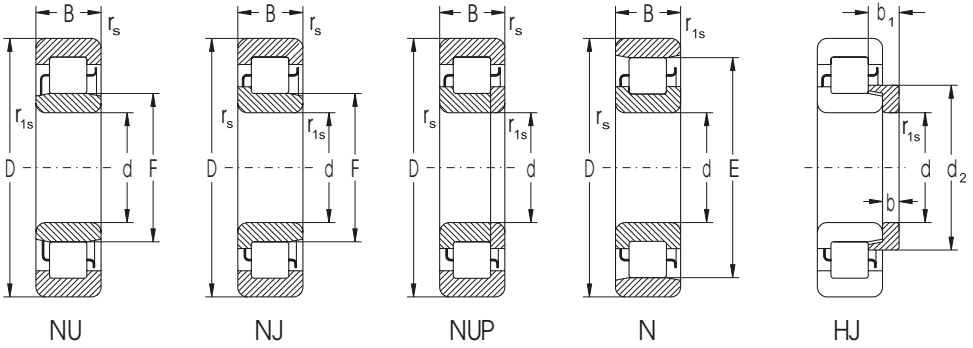

Dimensions											Bearing Designation					Angle Ring HJ
d	D	B	r <sub>s</sub>	r <sub>1s</sub>	F	E	d <sub>2</sub>	b	b <sub>1</sub>	s <sup>1)</sup>	NU	NJ	NUP	N	HJ	
mm																
65	120	23.00	1.5	1.5	79.60	105.6	85.6	6.0	11.00	1.6	<b>NU213</b>	<b>NJ213</b>	<b>NUP213</b>	<b>N213</b>	<b>HJ213</b>	
	120	31.00	1.5	1.5	79.60					1.6	<b>NU2213</b>	<b>NJ2213</b>	<b>NUP2213</b>			
	120	38.10	1.7	1.7	80.42					4.5	<b>NU5213M</b>					
	140	33.00	2.1	2.1	83.50	121.5	92.2	10.0	17.00	1.5	<b>NU313</b>	<b>NJ313</b>	<b>NUP313</b>	<b>N313</b>	<b>HJ313</b>	
	140	33.00	2.1	2.1	82.50		90.7	10.0	15.50	1.5	<b>NU313E</b>	<b>NJ313E</b>	<b>NUP313E</b>		<b>HJ313E</b>	
	140	48.00	2.1	2.1	83.50					4.5	<b>NU2313</b>	<b>NJ2313</b>	<b>NUP2313</b>			
	160	37.00	2.1	2.1	89.30		99.9	11.0	18.00	2.0	<b>NU413MAS</b>	<b>NJ413MAS</b>	<b>NUP413MAS</b>		<b>HJ413</b>	
70	125	24.00	1.5	1.5	84.50	110.5	90.5	7.0	12.50	1.6	<b>NU214</b>	<b>NJ214</b>	<b>NUP214</b>	<b>N214</b>	<b>HJ214</b>	
	125	31.00	1.5	1.5	84.50					1.6	<b>NU2214</b>	<b>NJ2214</b>	<b>NUP2214</b>			
	125	39.69	1.5	2.2	84.84					4.5	<b>NU5214M</b>					
	150	35.00	2.1	2.1	90.00	130.0	99.2	10.0	17.50	1.5	<b>NU314</b>	<b>NJ314</b>	<b>NUP314</b>	<b>N314</b>	<b>HJ314</b>	
	150	51.00	2.1	2.1	90.00					4.1	<b>NU2314</b>	<b>NJ2314</b>	<b>NUP2314</b>			
	150	51.00	2.1	2.1	89.00					4.1	<b>NU2314EMASNJ2314EMAS</b>	<b>NUP2314EMAS</b>				
	180	42.00	3.0	3.0	100.00	152.0	112.0	12.0	20.00	2.0	<b>NU414</b>	<b>NJ414</b>	<b>NUP414</b>	<b>N414</b>	<b>HJ414</b>	
75	130	25.00	1.5	1.5	88.50	116.5	94.9	7.0	12.50	1.6	<b>NU215</b>	<b>NJ215</b>	<b>NUP215</b>	<b>N215</b>	<b>HJ215</b>	
	130	25.00	1.5	1.5	88.50		94.6	7.0	11.00	1.6	<b>NU215E</b>	<b>NJ215E</b>	<b>NUP215E</b>		<b>HJ215E</b>	
	130	31.00	1.5	1.5	88.50					2.1	<b>NU2215E</b>	<b>NJ2215E</b>	<b>NUP2215E</b>			
	130	41.28	1.5	1.5	89.01					4.5	<b>NU5215M</b>					
	160	37.00	2.1	2.1	95.50	139.5	105.6	11.0	18.50	1.5	<b>NU315</b>	<b>NJ315</b>	<b>NUP315</b>	<b>N315</b>	<b>HJ315</b>	
	160	55.00	2.1	2.1	95.50					4.5	<b>NU2315</b>	<b>NJ2315</b>	<b>NUP2315</b>			
	190	45.00	3.0	2.0	104.50	160.5	117.0	13.0	21.50	2.0	<b>NU415</b>	<b>NJ415</b>	<b>NUP415</b>	<b>N415</b>	<b>HJ415</b>	
80	125	22.00	1.1	1.0	91.50					1.2	<b>NU1016</b>					
	140	26.00	2.0	2.0	95.30	125.3	102.2	8.0	13.50	2.0	<b>NU216</b>	<b>NJ216</b>	<b>NUP216</b>	<b>N216</b>	<b>HJ216</b>	
	140	33.00	2.0	2.0	95.30					2.5	<b>NU2216</b>	<b>NJ2216</b>	<b>NUP2216</b>			
	140	33.00	2.0	2.0	95.30					2.5	<b>NU2216E</b>	<b>NJ2216E</b>	<b>NUP2216E</b>			
	140	44.45	2.1	2.1	95.28					5.0	<b>NU5216M</b>					
	170	39.00	2.1	2.1	103.00	147.0	113.1	11.0	19.50	1.5	<b>NU316</b>	<b>NJ316</b>	<b>NUP316</b>	<b>N316</b>	<b>HJ316</b>	
	200	48.00	3.0	3.0	110.00	170.0	123.8	13.0	22.00	2.0	<b>NU416M</b>	<b>NJ416M</b>	<b>NUP416M</b>	<b>N416M</b>	<b>HJ416</b>	

<sup>1)</sup> Permissible axial displacement out of central position

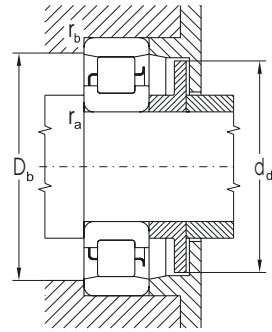
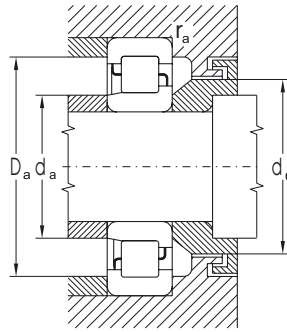
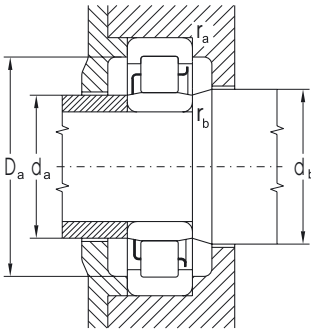

Basic Load Rating		Fatigue load limit P <sub>u</sub>	Limiting Speed for Lubrication with		Abutment and Fillet Dimensions									Weight		
Dynamic C <sub>r</sub>	Static C <sub>0r</sub>		Grease	Oil	d	d <sub>a</sub>	d <sub>a</sub> min	d <sub>b</sub> max	d <sub>c</sub> min	d <sub>d</sub> min	D <sub>a</sub> max	D <sub>b</sub> max	r <sub>a</sub> min	r <sub>b</sub> max	Bearing max	Angle Ring
kN		kN	min <sup>-1</sup>		mm									kg		
79.4	83	10.06	5300	6300	65	72	77	81	87	103	111	110	1.5	1.5	1.05	0.13
117.0	136	16.59	5300	6300		72	77	81	87	-	111	-	1.5	1.5	1.45	
139.0	196	23.90	4700	5600		77	-	83	-	-	108	-	1.5	1.5	1.88	
131.0	128	15.49	4500	5300		76	78	85	94	119	128	126	2.0	2.0	2.25	0.29
181.0	178	21.55	4200	5000		76	77	84	93	-	128	-	2.0	2.0	2.35	0.27
192.0	203	24.57	4500	5300		76	78	85	94	-	128	-	2.0	2.0	3.25	
181.0	174	20.48	3800	4500		78	83	91	101	-	146	-	2.0	2.0	3.60	0.43
79.4	83	10.06	5600	6700	70	77	82	86	92	108	116	115	1.5	1.5	1.15	0.16
117.0	139	16.95	5000	6000		77	82	86	92	-	116	-	1.5	1.5	1.50	
178.0	261	31.83	4700	5600		81.5	-	87	-	-	112	-	2.0	1.5	2.22	
147.0	144	17.07	4200	5000		81	85	92	101	127	138	135	2.0	2.0	2.75	0.34
215.0	233	27.61	4200	5000		81	85	92	101	-	138	-	2.0	2.0	5.25	
282.0	310	36.74	3800	4500		81	84	91	100	-	138	-	2.0	2.0	4.21	
224.0	215	24.52	3300	4000		85	93	102	114	149	164	156	2.5	2.5	5.25	0.61
96.2	96	11.65	4700	5600	75	82	85	90	96	114	121	120	1.5	1.5	1.25	0.17
131.0	147	17.79	4500	5300		82	85	90	96	-	121	-	1.5	1.5	1.30	0.16
162.0	196	23.73	4500	5300		82	85	90	96	-	121	-	1.5	1.5	1.65	
196.0	299	36.19	4500	5300		85.5	-	91	-	-	117	-	2.0	1.5	2.41	
178.0	178	20.68	3800	4500		86	93	97	107	137	148	145	2.0	2.0	3.25	0.40
266.0	287	33.35	3800	4500		86	93	97	107	-	148	-	2.0	2.0	4.85	
261.0	251	28.13	3200	3800		90	98	107	119	158	174	164	2.5	2.5	6.25	0.80
66.8	76	9.25	5000	6000	80	85	90	94	-	-	118	-	1.0	1.0	0.99	
106.0	114	13.51	4500	5300		90	92	97	104	125	130	130	2.0	2.0	1.50	0.21
147.0	178	21.10	4500	5300		90	92	97	104	-	130	-	2.0	2.0	1.95	
196.0	246	29.15	4200	5000		90	92	97	104	-	130	-	2.0	2.0	2.05	
185.0	282	33.42	4200	5000		91.5	-	98	-	-	126	-	2.0	2.0	2.91	
192.0	192	21.90	3500	4200	80	99	97	105	116	144	158	153	2.0	2.0	3.90	0.49
299.0	293	32.30	3000	3500		95	105	112	125	167	184	174	2.5	2.5	7.30	0.80

# Single Row Cylindrical Roller Bearings

d = 85 to 105 mm

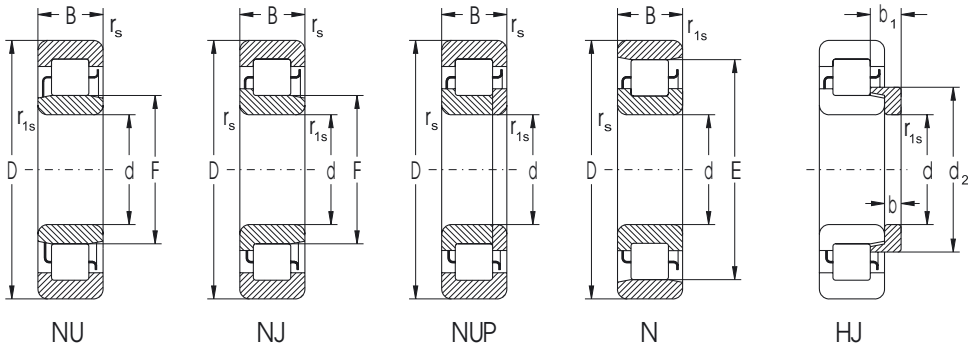

Dimensions										Bearing Designation				Angle Ring HJ	
d	D	B	r <sub>s</sub> min	r <sub>1s</sub> min	F	E	d <sub>2</sub> max	b	b <sub>1</sub>	s <sup>1)</sup>	NU	NJ	NUP	N	
mm															
85	150	28.00	2.0	2.0	101.80	133.8	109.2	8.0	14.00	2.0	<b>NU217</b>	<b>NJ217</b>	<b>NUP217</b>	<b>N217</b>	<b>HJ217</b>
	150	36.00	2.0	2.0	100.50					2.0	<b>NU2217E</b>	<b>NJ2217E</b>	<b>NUP2217E</b>		
	150	49.21	2.1	2.1	102.00					5.5	<b>NU5217M</b>				
	180	41.00	3.0	3.0	108.00	156.0	119.0	12.0	20.00	2.0	<b>NU317</b>	<b>NJ317</b>	<b>NUP317</b>	<b>N317</b>	<b>HJ317</b>
	210	52.00	4.0	4.0	113.00		127.7	14.0	24.00	2.5	<b>NU417</b>	<b>NJ417</b>	<b>NUP417</b>		<b>HJ417</b>
90	160	30.00	2.0	2.0	107.00	143.0	115.3	9.0	15.00	2.0	<b>NU218</b>	<b>NJ218</b>	<b>NUP218</b>	<b>N218</b>	<b>HJ218</b>
	160	52.40	2.1	3.0	107.22					6.0	<b>NU5218M</b>				
	190	43.00	3.0	3.0	115.00	165.0	126.5	12.0	21.00	2.0	<b>NU318</b>	<b>NJ318</b>	<b>NUP318</b>	<b>N318</b>	<b>HJ318</b>
	190	43.00	3.0	3.0	113.50		124.2	12.0	18.50	2.0	<b>NU318E</b>	<b>NJ318E</b>	<b>NUP318E</b>		<b>HJ318E</b>
	225	54.00	4.0	4.0	123.50		139.1	14.0	24.00	2.5	<b>NU418</b>	<b>NJ418</b>	<b>NUP418</b>		<b>HJ418</b>
	225	54.00	4.0	4.0	123.50		139.1	14.0	24.00	2.5	<b>NU418MAS</b>	<b>NJ418MAS</b>	<b>NUP418MAS</b>		<b>HJ418</b>
95	170	32.00	2.1	2.1	113.50	151.5	122.2	9.0	15.50	2.0	<b>NU219</b>	<b>NJ219</b>	<b>NUP219</b>	<b>N219</b>	<b>HJ219</b>
	170	43.00	2.1	2.1	113.50					3.0	<b>NU2219</b>	<b>NJ2219</b>	<b>NUP2219</b>		
	170	55.56	2.5	3.0	113.52					6.0	<b>NU5219M</b>				
	200	45.00	3.0	3.0	121.50	173.5				2.0	<b>NU319</b>	<b>NJ319</b>	<b>NUP319</b>	<b>N319</b>	
	200	45.00	3.0	3.0	121.50					1.9	<b>NU319EM</b>	<b>NJ319EM</b>	<b>NUP319EM</b>		
	240	55.00	4.0	4.0	133.50					2.5	<b>NU419M</b>	<b>NJ419M</b>	<b>NUP419M</b>		
100	180	34.00	2.1	2.1	120.00	160.0	129.2	10.0	17.00	2.0	<b>NU220</b>	<b>NJ220</b>	<b>NUP220</b>	<b>N220</b>	<b>HJ220</b>
	180	46.00	2.1	2.1	120.00					3.0	<b>NU2220</b>	<b>NJ2220</b>	<b>NUP2220</b>		
	180	60.32	2.1	2.1	121.01					7.0	<b>NU5220M</b>				
	215	47.00	3.0	3.0	129.50	185.5	142.4	13.0	22.50	2.0	<b>NU320</b>	<b>NJ320</b>	<b>NUP320</b>	<b>N320</b>	<b>HJ320</b>
	215	73.00	3.0	3.0	127.50					4.9	<b>NU2320EMAS</b>		<b>NJ2320EMAS</b>	<b>NUP2320EMAS</b>	
	250	58.00	4.0	4.0	139.00		155.9	16.0	27.00	2.5	<b>NU420</b>	<b>NJ420</b>	<b>NUP420</b>		<b>HJ420</b>
105	190	36.00	2.1	2.1	126.80	168.8	136.5	10.0	17.50	2.0	<b>NU221</b>	<b>NJ221</b>	<b>NUP221</b>	<b>N221</b>	<b>HJ221</b>
	190	65.10	2.1	2.1	126.52					7.0	<b>NU5221M</b>				
	225	49.00	3.0	3.0	135.00	195.0	148.8	13.0	22.50	4.5	<b>NU321</b>	<b>NJ321</b>	<b>NUP321</b>	<b>N321</b>	<b>HJ321</b>
	260	60.00	4.0	4.0	144.50		162.0	16.0	27.00	2.5	<b>NU421</b>	<b>NJ421</b>	<b>NUP421</b>		<b>HJ421</b>

<sup>1)</sup> Permissible axial displacement out of central position



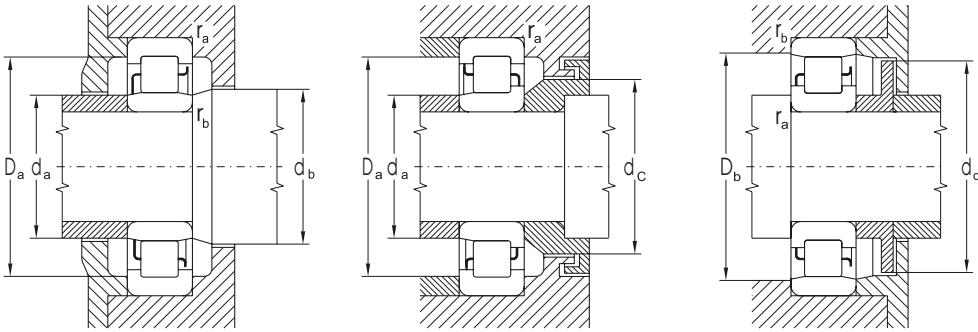

Basic Load Rating		Fatigue load limit $P_u$	Limiting Speed for Lubrication with		Abutment and Fillet Dimensions										Weight	
Dynamic $C_r$	Static $C_{or}$		Grease	Oil	d	$d_a$	$d_a$ min	$d_b$ max	$d_c$ min	$d_d$ min	$D_a$ max	$D_b$ max	$r_a$ min	$r_b$ max	Bearing max	Angle Ring
kN		kN	$\text{min}^{-1}$		mm										kg	
121.0	131	15.22	4200	5000	85	95	99	104	111	131	140	138	2.0	2.0	1.90	0.25
220.0	261	30.33	3800	4500		95	98	103	110	-	140	--	2.0	2.0	2.52	
211.0	316	36.72	3800	4500		98	-	105	-	-	135	-	2.0	2.0	3.69	
215.0	215	24.10	3300	4000		98	103	110	121	174	166	162	2.5	2.5	4.50	0.57
362.0	362	39.29	3000	3500		105	108	115	129	-	190	-	3.0	3.0	8.70	0.89
147.0	158	18.02	4000	4700	90	100	105	109	117	140	150	147	2.0	2.0	2.30	0.31
237.0	355	40.49	3500	4200		103	-	110	-	-	144	-	2.5	2.0	4.48	
233.0	242	26.68	3200	3800		103	111	117	128	162	176	172	2.5	2.5	5.40	0.65
316.0	329	36.27	3000	3500		103	110	116	127	-	176	-	2.5	2.5	5.50	0.60
391.0	406	43.20	2700	3200		110	117	125	140	-	205	-	3.0	3.0	11.70	1.05
391.0	406	43.20	2700	3200		110	117	125	140	-	205	-	3.0	3.0	11.70	1.05
162.0	181	20.29	3800	4500	95	107	111	116	124	149	158	155	2.0	2.0	2.80	0.35
233.0	282	31.61	3800	4500		107	111	116	124	-	158	-	2.0	2.0	3.85	
335.0	511	57.27	3300	4000		110	-	117	-	-	153	-	2.5	2.0	5.65	
256.0	266	28.87	3200	3800		109	119	124	135	170	186	178	2.5	2.5	6.20	
329.0	362	39.29	2800	3300		109	119	124	135	-	186	-	2.5	2.5	6.50	
430.0	447	46.70	2500	3000		115	125	136	151	-	220	-	3.0	3.0	13.50	
178.0	203	22.38	3500	4200	100	112	117	122	131	157	168	165	2.0	2.0	3.40	0.45
261.0	322	40.53	3500	4200		112	117	122	131	-	168	-	2.0	2.0	4.65	
304.0	473	59.54	3200	3800		116.5	-	124	-	-	162	-	2.0	2.0	6.49	
299.0	310	36.99	2800	3300		113	125	132	145	182	201	190	2.0	2.0	7.70	0.91
596.0	694	82.82	2500	3000		113	123	130	144	-	201	-	2.5	2.5	12.50	
473.0	501	57.14	2400	2800		120	130	141	158	-	230	-	3.0	3.0	14.00	1.55
200.0	224	24.31	3300	4000	105	117	122	129	138	166	178	175	2.0	2.0	4.00	0.51
362.0	573	62.19	3000	3500		121.5	-	130	-	-	171	-	2.0	2.0	7.94	
341.0	362	37.99	2700	3200		119	132	137	150	192	211	199	2.5	2.5	8.75	1.00
531.0	562	57.22	2200	2700		125	135	147	164	-	240	-	3.0	3.0	19.00	1.65

# Single Row Cylindrical Roller Bearings

d = 110 to 150 mm

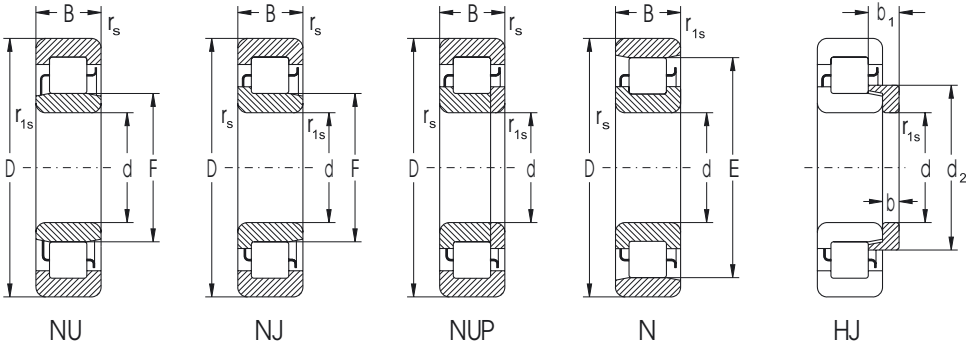

Dimensions										Bearing Designation				Angle Ring HJ	
d	D	B	r <sub>s</sub> min	r <sub>1s</sub> min	F	E	d <sub>2</sub> max	b <sub>1</sub>	s <sup>1)</sup>	NU	NJ	NUP	N	HJ	
mm															
110	200	38.00	2.1	2.1	132.50	178.5	143.1	11.0	18.50	2.5	<b>NU222</b>	<b>NJ222</b>	<b>NUP222</b>	<b>N222</b>	<b>HJ222</b>
	200	53.00	2.1	2.1	132.50					5.0	<b>NU2222</b>	<b>NJ2222</b>	<b>NUP2222</b>		
	200	69.85	2.1	4.0	132.95					7.0	<b>NU5222M</b>				
	240	50.00	3.0	3.0	143.00	207.0	157.5	14.0	23.00	2.7	<b>NU322</b>	<b>NJ322</b>	<b>NUP322</b>	<b>N322</b>	<b>HJ322</b>
	240	50.00	3.0	3.0	143.00					2.9	<b>NU322E</b>	<b>NJ322E</b>	<b>NUP322E</b>		
	280	65.00	4.0	4.0	155.00		173.4	17.0	29.50	2.7	<b>NU422</b>	<b>NJ422</b>	<b>NUP422</b>		<b>HJ422</b>
120	180	28.00	2.0	1.1	135.00					2.0	<b>NU1024</b>				
	215	40.00	2.1	2.1	143.50	191.5	154.5	11.0	19.00	2.5	<b>NU224</b>	<b>NJ224</b>	<b>NUP224</b>	<b>N224</b>	<b>HJ224</b>
	215	58.00	2.1	2.1	143.50					5.4	<b>NU2224</b>	<b>NJ2224</b>	<b>NUP2224</b>		
	215	76.20	2.1	2.1	145.14					7.0	<b>NU5224M</b>				
	260	55.00	3.0	3.0	154.00		170.5	14.0	23.50	2.7	<b>NU324</b>	<b>NJ324</b>	<b>NUP324</b>		<b>HJ324</b>
	260	86.00	3.0	3.0	154.00					6.4	<b>NU2324EMAS</b>		<b>NJ2324EMAS</b>	<b>NUP2324EMAS</b>	
310	72.00	5.0	6.0	170.00		188.0	17.0	30.50	2.7	<b>NU424</b>	<b>NJ424</b>	<b>NUP424</b>		<b>HJ424</b>	
130	200	33.00	2.0	1.1	148.00					2.0	<b>NU1026</b>				
	230	40.00	3.0	3.0	156.00	204.0	167.0	11.0	19.00	2.5	<b>NU226</b>	<b>NJ226</b>	<b>NUP226</b>	<b>N226</b>	<b>HJ226</b>
	230	79.38	4.0	4.0	155.00					8.0	<b>NU5226M</b>				
140	280	58.00	4.0	4.0	167.00		182.3	14.0	23.00	2.9	<b>NU326E</b>	<b>NJ326E</b>	<b>NUP326E</b>		<b>HJ326E</b>
	250	42.00	3.0	3.0	169.00	221.0	181.0	11.0	19.00	2.5	<b>NU228</b>	<b>NJ228</b>	<b>NUP228</b>	<b>N228</b>	<b>HJ228</b>
	250	82.55	4.0	4.0	168.46					10.0	<b>NU5228M</b>				
	300	62.00	4.0	4.0	180.00		198.4	15.0	26.00	2.7	<b>NU328</b>	<b>NJ328</b>	<b>NUP328</b>		<b>HJ328</b>
150	225	35.00	2.1	1.5	169.50					2.0	<b>NU1030</b>				
	270	45.00	3.0	3.0	182.00		194.7	12.0	20.50	2.4	<b>NU230</b>	<b>NJ230</b>	<b>NUP230</b>		<b>HJ230</b>
	270	45.00	3.0	3.0	182.00		193.7	12.0	19.50	2.4	<b>NU230E</b>	<b>NJ230E</b>	<b>NUP230E</b>		<b>HJ230E</b>
	270	88.90	2.3	2.3	181.54					10.0	<b>NU5230M</b>				
	320	65.00	4.0	4.0	193.00		212.3	15.0	26.50	2.7	<b>NU330</b>	<b>NJ330</b>	<b>NUP330</b>		<b>HJ330</b>

<sup>1)</sup> Permissible axial displacement out of central position

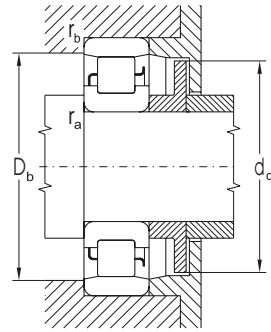
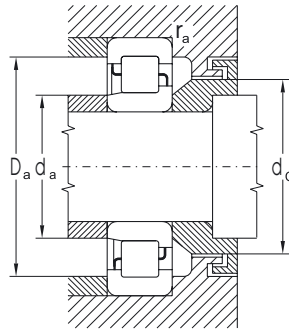
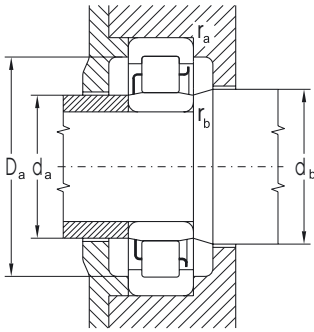

Basic Load Rating	Fatigue load limit	Limiting Speed for Lubrication with	Abutment and Fillet Dimensions												Weight	
			Dynamic C <sub>r</sub>	Static C <sub>0r</sub>	Grease	Oil	d	d <sub>a</sub>	d <sub>a</sub> <sub>min</sub>	d <sub>b</sub> <sub>max</sub>	d <sub>c</sub> <sub>min</sub>	d <sub>d</sub> <sub>min</sub>	D <sub>a</sub> <sub>max</sub>	D <sub>b</sub> <sub>max</sub>	r <sub>a</sub> <sub>min</sub>	r <sub>b</sub> <sub>max</sub>
kN	kN	min <sup>-1</sup>	mm												kg	
237.0	271	28.98	3200	3800	110	122	125	135	145	175	188	182	2.0	2.0	4.65	0.62
341.0	422	45.12	3200	3800		122	125	135	145	-	188	-	2.0	2.0	6.95	
464.0	736	78.70	3000	3500	128	-	137	-	-	180	-	3.0	2.0	10.00		
391.0	414	42.68	2500	3000	124	135	145	160	204	226	211	2.5	2.5	10.50	1.17	
447.0	492	50.73	2400	2800	124	135	145	160	-	226	-	2.5	2.5	11.00		
584.0	631	62.98	2100	2500	130	140	157	175	-	260	-	3.0	3.0	20.00	2.16	
131.0	168	18.14	3300	4000	120	128	131	138	-	171	-	2.0	1.0	2.45		
261.0	299	31.24	3000	3500	132	138	146	157	188	203	196	2.0	2.0	5.65	0.72	
369.0	473	49.41	3000	3500	132	138	146	157	-	203	-	2.0	2.0	8.55		
482.0	794	82.95	2700	3200	140	-	149	-	-	194	-	2.0	2.0	11.80		
447.0	473	47.58	2400	2800	134	145	156	172	-	246	-	2.5	2.5	13.00	1.40	
810.0	981	98.68	2100	2500	134	145	156	172	-	246	-	2.5	2.5	24.50		
736.0	810	78.51	1900	2200	144	155	172	192	-	286	-	4.0	4.0	28.00	2.60	
162.0	203	21.30	3200	3800	130	138	143	151	-	191	-	2.0	1.0	3.75		
271.0	322	32.92	2700	3200	144	150	158	169	201	216	208	2.5	2.5	6.50	0.84	
511.0	841	85.98	2500	3000	149	-	159	-	-	207	-	3.0	2.0	13.80		
619.0	694	68.24	2000	2400	148	155	169	186	-	262	-	3.0	3.0	17.00	1.65	
310.0	369	36.83	2500	3000	140	154	160	171	182	218	236	255	2.5	2.5	8.25	1.00
596.0	981	97.91	2200	2700	162	-	173	-	-	225	-	3.0	3.0	17.10		
619.0	708	68.15	2000	2400	158	166	182	198	-	282	-	3.0	3.0	20.00	2.05	
192.0	251	25.35	2700	3200	150	159	165	173	-	213	-	2.0	1.5	4.85		
369.0	455	44.42	2200	2700	164	170	184	196	-	256	-	2.5	2.5	10.50	1.35	
447.0	552	53.88	2200	2700	164	170	184	196	-	256	-	2.5	2.5	11.00	1.30	
736.0	1260	123.00	2000	2400	174	-	187	-	-	243	-	5.0	2.0	22.90		
681.0	779	73.52	1900	2200	168	185	195	213	-	302	-	3.0	3.0	27.00	2.37	



# Single Row Cylindrical Roller Bearings

d = 160 to 1180 mm

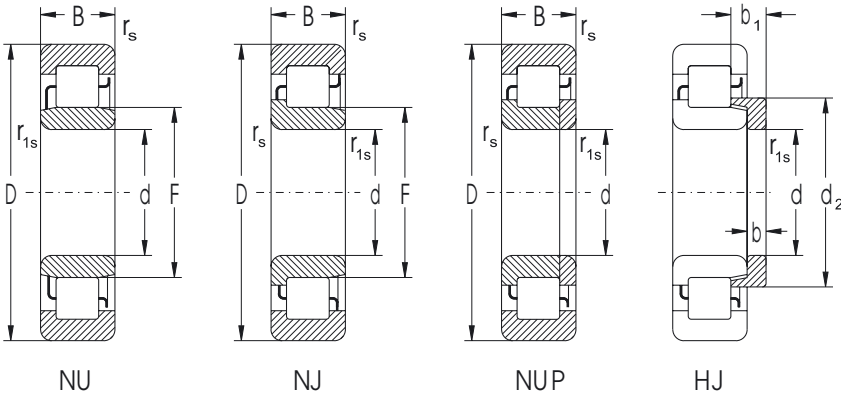

Dimensions										Bearing Designation				Angle Ring HJ
d	D	B	r <sub>s</sub> min	r <sub>1s</sub> min	F	d <sub>2</sub> max	b	b <sub>1</sub>	s <sup>1)</sup>	NU	NJ	NUP	N	HJ
mm														
160	290	48.00	3.0	3.0	195.000	207.4	12.0	20.0	2.50	<b>NU232M</b>	<b>NJ232M</b>	<b>NUP232M</b>		<b>HJ232</b>
	290	98.42	2.5	6.3	193.634				10.00	<b>NU5232M</b>				
170	260	42.00	2.1	2.1	193.000				3.00	<b>NU1034</b>				
	310	52.00	4.0	4.0	207.000	228.8	12.0	20.0	2.90	<b>NU234M</b>	<b>NJ234M</b>	<b>NUP234M</b>		<b>HJ234</b>
	310	104.77	3.2	6.3	205.483				10.00	<b>NU5234M</b>				
180	280	46.00	2.1	2.1	205.000				3.60	<b>NU1036</b>				
	320	52.00	4.0	4.0	217.000	230.8	12.0	20.0	2.90	<b>NU236M</b>	<b>NJ236M</b>	<b>NUP236M</b>		<b>HJ236</b>
	320	86.00	4.0	4.0	218.000	230.5	12.0	29.0	6.90	<b>NU2236M</b>	<b>NJ2236M</b>	<b>NUP2236M</b>		<b>HJ2236</b>
200	310	51.00	2.1	2.1	229.000				4.20	<b>NU1040</b>				
	360	58.00	4.0	4.0	243.000	258.2	14.0	23.0	2.90	<b>NU240E</b>	<b>NJ240E</b>	<b>NUP240E</b>		<b>HJ240E</b>
220	340	56.00	3.0	3.0	250.000				4.10	<b>NU1044</b>				
240	360	56.00	3.0	3.0	270.000				4.10	<b>NU1048</b>				
	440	72.00	5.0	5.0	295.000				4.00	<b>NU248</b>	<b>NJ248</b>			
	440	72.00	5.0	5.0	295.000	315.0	16.0	25.9	4.00	<b>NUJ248</b>	<b>NH248</b>			<b>HJ248</b>
260	400	65.00	4.0	4.0	296.000				2.00	<b>NU1052</b>				
	480	130.00	5.0	5.0	320.000				4.30	<b>NU2252</b>				
280	420	65.00	4.0	4.0	316.000				5.00	<b>NU1056</b>				
300	460	74.00	5.0	5.0	340.000				4.50	<b>NU1060</b>	<b>NJ1060</b>			
	460	74.00	5.0	5.0	340.000	357.6	19.0	36.0	4.50	<b>NUJ1060</b>	<b>NH1060</b>			<b>HJ1060</b>
320	480	74.00	4.0	4.0	360.000				5.00	<b>NU1064</b>				
360	540	82.00	6.0	6.0	480.000				5.00	<b>NU1072</b>				
	540	82.00	6.0	6.0	480.000	423.0	21.0	39.5	5.00	<b>NUJ1072</b>	<b>NH1072</b>			<b>HJ1072</b>
380	560	82.00	5.0	5.0	425.000				6.00	<b>NU1076</b>				
400	600	90.00	5.0	5.0	450.000	470.0	19.6	42.6	5.00	<b>NU1080</b>	<b>NUJ1080</b>			<b>HJ1080</b>
	600	148.00	5.0	5.0	450.000				5.00	<b>NU3080</b>				
	720	185.00	6.0	6.0	480.000				16.00	<b>NU2280</b>				
600	800	118.00	5.0	5.0	650.000				12.00	<b>NU29/600</b>		<b>NUP29/600</b>		
	830	150.00	4.7	4.7	659.000				7.00	<b>NU39/600MA</b>				
850	1120	155.00	8.0	8.0	925.000				15.00	<b>NU29/850</b>		<b>NUP29/850</b>		
900	1180	165.00	8.0	8.0	982.000				17.00	<b>NU29/900</b>		<b>NUP29/900</b>		
950	1250	175.00	10.0	10.0	1032.000				17.00	<b>NU29/950</b>		<b>NUP29/950</b>		
1000	1320	185.00	10.0	10.0	1090.000				17.00	<b>NU29/1000</b>		<b>NUP29/1000</b>		
1060	1400	195.00	10.0	10.0	1155.000				20.00	<b>NU29/1060</b>		<b>NUP29/1060</b>		
1180	1540	206.00	10.0	10.0	1280.000				21.00	<b>NU29/1180</b>		<b>NUP29/1180</b>		

<sup>1)</sup> Permissible axial displacement out of central position

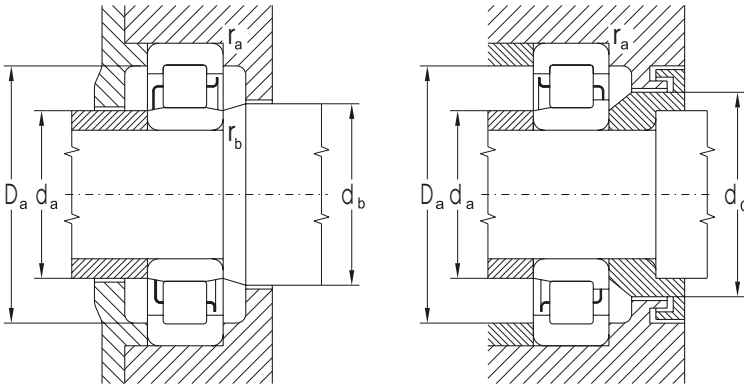

Basic Load Rating		Fatigue load limit $P_u$	Limiting Speed for Lubrication with		Abutment and Fillet Dimensions								Weight	
Dynamic $C_r$	Static $C_{or}$		Grease	Oil	d	$d_a$ min	$d_a$ max	$d_b$ min	$d_c$ min	$D_a$ max	$r_a$ max	$r_b$ max	Bearing	Angle Ring
kN		kN	min <sup>-1</sup>		mm								kg	
511	631.0	60.33	2000	2400	160	174	180	197	210	276	2.5	2.5	14.7	1.50
764	1310.0	125.26	1900	2200		186	-	199	-	261	5.0	2.0	28.9	
276	376.0	36.45	2200	2700	170	179	190	197	-	248	2.0	2.0	7.9	
607	750.0	70.34	1900	2200		188	195	211	223	293	3.0	3.0	16.6	1.70
891	1470.0	137.86	1800	2100		197	-	211	-	279	5.0	3.0	35.5	
329	447.0	42.46	2100	2500	180	189	196	209	-	268	2.0	2.0	10.50	
631	794.0	73.56	1800	2100		198	207	220	233	302	3.0	3.0	19.5	1.80
736	1060.0	98.20	1800	2100		198	208	221	233	302	3.0	3.0	31.2	1.90
383	531.0	48.90	1900	2200	200	212	220	233	-	298	2.0	2.0	14.0	
779	1000.0	89.54	1500	1800		218	227	246	261	342	3.0	3.0	28.4	2.70
501	694.0	62.14	1700	200	220	234	240	254	-	326	2.5	2.5	18.5	
531	764.0	67.01	1600	1900	240	254	260	275	-	346	2.5	2.5	20.0	
944	1280.0	108.13	1300	1600		258	293	298	316	422	3.0	3.0	50.5	
944	1280.0	108.13	1300	1600		258	293	298	316	422	3.0	3.0	50.5	4.68
643	962.0	82.00	1400	1700	260	278	280	300	-	382	3.0	3.0	29.0	
1760	2900.0	238.85	1100	1400		280	309	324	-	460	4.0	4.0	90.0	
681	1020.0	85.42	1300	1600	280	296	311	320	-	404	3.0	3.0	32.5	
891	1310.0	107.03	1200	1400	300	318	325	344	360	442	3.0	3.0	43.6	
891	1310.0	107.03	1200	1400		318	325	344	360	442	3.0	3.0	43.6	5.63
909	1390.0	111.84	1100	1300	320	336	355	364	-	464	3.0	3.0	48.5	
1076	1753.0	136.15	950	1100	360	382	390	410	-	518	4.0	4.0	67.5	
1076	1753.0	136.15	950	1100		382	390	410	427	518	4.0	4.0	67.5	10.00
1166	1982.0	151.94	850	1000	380	400	420	430	-	540	4.0	4.0	71.0	
1470	2330.0	175.33	840	1000	400	422	435	455	-	578	4.0	4.0	89.0	10.50
2255	4900.0	368.72	760	910		422	435	455	-	578	4.0	4.0	150.5	
3410	5960.0	433.49	710	840		426	460	485	-	694	5.0	5.0	350.0	
2230	4853.0	330.12	560	700	600	614	644	654	675	750	4.0	4.0	173.0	
2860	6200.0	419.07	500	600	600	614	645	660	680	790	4.7	4.7	262.0	
3760	8740.0	536.62	380	450	850	878	920	930	952	1092	5.0	5.0	430.0	
4220	9810.0	592.58	300	400	900	928	977	987	1011	1152	5.0	5.0	500.0	
4577	11452.0	680.22	300	370	950	978	1027	1041	1066	1220	5.0	5.0	597.0	
4920	11600.0	678.12	300	350	1000	1036	1085	1095	1122	1284	6.0	6.0	720.0	
5410	12800.0	735.23	280	330	1060	1096	1150	1160	1189	1364	6.0	6.0	850.0	
6310	15300.0	852.74	250	300	1180	1216	1275	1285	1316	1504	6.0	6.0	1050.0	

# Double Row Cylindrical Roller Bearings

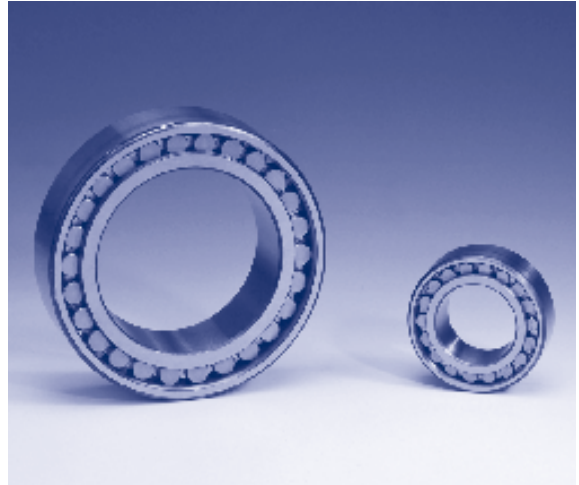

Double row cylindrical roller bearings in NN design have two rows of cylindrical rollers guided by three ribs on inner ring. The outer ring is without ribs, that is why these bearings cannot carry axial forces. Double row cylindrical roller bearings - type NN30K are commonly produced with tapered bore, taper 1:12 (K). These bearings can be also delivered with cylindrical bore (must be agreed in advance). Double row cylindrical roller bearings are significant for their great rigidity and are predominately used for spindle arrangements of machine tools and similar equipment. Double row cylindrical roller bearings - type NNU49 have three guiding ribs on outer ring and smooth inner ring. Bearings can carry only radial loads. Bearings - type NNU4920 and NNU4924 are also delivered matched in pairs according to the technical conditions TPF 11322-80. In this way matched bearing pairs fulfil in the arrangement the role of four-row cylindrical roller bearings and are suitable for arrangement of rolls in rolling mills, etc.

## Boundary Dimensions

Boundary dimensions comply with the standard ISO 15 and are shown in the dimension tables of this publication.

## Designation

Bearing designation in standard design is in the dimension tables of this publication.

Difference from standard design is designated by additional symbols according to ISO 02 4608 (section 2.2).

## Lubrication Groove and Holes on Outer Ring

All sizes of double row cylindrical roller bearings with tapered bore - type NN30K can be delivered with groove and lubrication holes on outer ring (W33). This bearing design allows the introduction of the lubricant directly into the bearing between two cylindrical roller rows. In this way better bearing lubrication and higher operating reliability are reached.

## Cages

Cylindrical roller bearings are commonly produced with a machined brass cage which is usually not designated. Bearings type NNU49 are produced with machined brass cage (M) which is designated.

## Tolerance

Cylindrical roller bearings with tapered bore are produced only in higher tolerance classes P5 and P4. Limiting values for dimension and operation accuracy for tolerance classes P5 and P4 are in tables 12 and 13.

Bearings NNU49 and NN39 are produced in normal tolerance class. Bearing delivery in tolerance class P6 should be agreed with the supplier in advance.

## Radial Clearance

Cylindrical roller bearings with a tapered bore are produced with reduced radial clearance and with mutually non-interchangeable rings C1NA and C2NA. Symbols C1NA and C2NA are connected with tolerance class symbols P5 and P4, e.g. P5 + C1NA is designated P51NA. Values of radial clearance are shown in table 25. Bearings - type NNU49 are produced with normal radial clearance. Bearings delivery with radial clearance greater than C3 should be discussed with the supplier.

## Misalignment

Double row cylindrical roller bearings are not suitable for arrangements where alignment of inner and outer bearing rings is not secured.

## Radial Equivalent Dynamic Load

$$P_r = F_r \quad [\text{kN}]$$

## Radial Equivalent Static Load

$$P_{or} = F_r \quad [\text{kN}]$$



# Double Row Cylindrical Roller Bearings

d = 25 to 630 mm

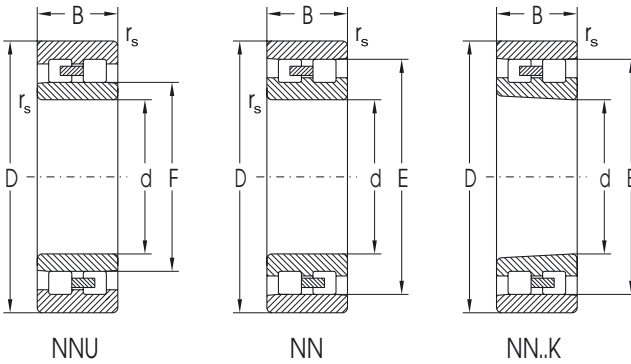

Dimensions						Basic Load Rating		Fatigue load	Limiting Speed for		
d	D	B	r <sub>s</sub>	E	F	s <sup>1)</sup>	C <sub>r</sub>	C <sub>or</sub>	P <sub>u</sub>	Lubrication with Grease	Oil
mm							kN		kN	min <sup>-1</sup>	
25	47	16	1.0	41.3		1.0	21.5	23.8	2.90	19000	22000
30	55	19	1.0	48.5		1.0	28.7	32.5	3.96	16000	18000
35	62	20	1.0	55.0		1.0	36.9	43.8	5.34	14000	16000
40	68	21	1.0	61.0		1.0	38.3	44.7	5.45	12600	14000
45	75	23	1.0	67.5		1.0	44.7	53.1	6.48	11000	12600
50	80	23	1.0	72.5		1.0	48.2	59.6	7.27	10600	12000
55	90	26	1.1	81.0		1.2	64.3	81.0	9.88	9400	11000
60	95	26	1.1	86.1		1.2	68.1	89.1	10.87	8900	10000
65	100	26	1.1	91.0		1.2	70.8	98.1	11.96	8400	9400
70	110	30	1.1	100.0		1.2	90.9	128.0	15.61	7500	8400
75	115	30	1.1	105.0		1.2	90.9	128.0	15.61	7100	7900
80	125	34	1.1	113.0		1.4	114.0	162.0	19.76	6700	7500
85	130	34	1.1	118.0		1.4	119.0	178.0	21.71	6300	7100
90	140	37	1.5	127.0		1.4	131.0	192.0	23.41	6000	6700
95	145	37	1.5	132.0		14.0	139.0	207.0	25.24	5600	6300
100	150	37	1.5	137.0		1.5	144.0	224.0	27.32	5300	6000
	140	40	1.1		113.0	1.7	119.0	215.0	26.22	3800	4700
105	160	41	2.0	146.0		1.5	188.0	282.0	20.85	5000	5600
110	170	45	2.0	155.0		1.5	220.0	329.0	23.93	4700	5300
120	180	46	2.0	165.0		1.5	228.0	355.0	25.29	4500	5000
	165	40	1.1		134.5	1.7	168.0	304.0	21.99	3200	4000
130	200	52	2.0	182.0		1.5	282.0	447.0	30.95	4000	4500
140	210	53	2.0	192.0		1.5	299.0	482.0	32.79	3800	4200
150	225	56	2.1	206.0		1.5	322.0	521.0	34.71	3500	4000
220	300	60	3.5	278.0		2.0	299.0	668.0	40.35	1800	2200
240	320	60	3.5	298.0		2.0	316.0	750.0	44.31	1600	2000
280	420	106	5.0	384.0		6.7	1100.0	2000.0	110.50	1300	1600
320	480	121	5.0	438.0		8.0	1360.0	2510.0	133.24	1200	1400
340	520	133	6.0	473.0		9.0	1680.0	3100.0	161.02	1100	1300
360	540	134	6.0	493.0		9.0	1740.0	3350.0	171.65	1000	1200
440	650	157	8.0	596.0		13.0	2460.0	4920.0	238.02	750	890
630	850	218	8.0		704.0	5.0	3910.0	10200.0	450.19	470	600

1) Permissible axial displacement



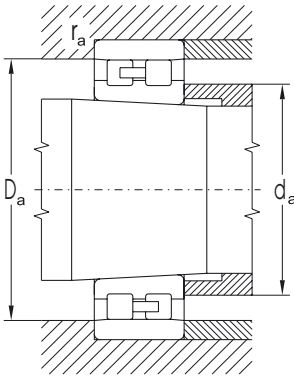

Bearing Designation	Abutment and Fillet Dimensions					Weight			
	with Cylindrical Bore	with Tapered Bore	$d_a$ min	$D_a$ min	$D_a$ max	$r_a$ max	~	K	
			mm					kg	
<b>NN3005K</b>			25	29	42	43	1.0		0.12
<b>NN3006K</b>			30	35	49	50	1.0		0.19
<b>NN3007K</b>			35	40	56	57	1.0		0.25
<b>NN3008K</b>			40	45	62	63	1.0		0.30
<b>NN3009K</b>			45	50	69	70	1.0		0.38
<b>NN3010K</b>			50	55	74	75	1.0		0.42
<b>NN3011K</b>			55	62	82	84	1.0		0.62
<b>NN3012K</b>			60	67	87	88	1.0		0.66
<b>NN3013K</b>			65	72	92	93	1.0		0.71
<b>NN3014K</b>			70	77	102	103	1.0		1.00
<b>NN3015K</b>			75	82	107	108	1.0		1.10
<b>NN3016K</b>			80	87	115	118	1.0		1.50
<b>NN3017K</b>			85	92	120	123	1.0		1.60
<b>NN3018K</b>			90	98	129	132	1.5		2.00
<b>NN3019K</b>			95	103	134	137	1.5		2.10
<b>NN3020K</b>			100	108	139	142	1.5		2.20
<b>NU4920M</b>			100	106	129	134	1.0	1.92	
<b>NN3021K</b>			105	114	148	151	2.0		2.80
<b>NN3022K</b>			110	119	157	161	2.0		3.55
<b>NN3024K</b>			120	129	167	171	2.0		3.85
<b>NU4924M</b>			120	126	153	159	1.0	2.81	
<b>NN3026K</b>			130	139	184	191	2.0		5.75
<b>NN3028K</b>			140	150	194	200	2.0		6.20
<b>NN3030K</b>			150	162	208	213	2.0		7.50
<b>NN3944</b>			220				*	12.00	
<b>NN3948</b>			240				*	13.00	
<b>NN3056K</b>			280	298	388	402	3.0	-	49.60
<b>NN3064K</b>			320	338	442	462	3.0	-	74.20
<b>NN3068K</b>			340	362	477	498	4.0	-	99.00
<b>NN3072K</b>			360	382	497	518	4.0	-	105.00
<b>NN3088K</b>			440	468	602	622	5.0	-	169.40
<b>NU49/630</b>			630				*	363.00	

# Single Row Needle Roller Bearings



Single row needle roller bearings have needle rollers guided in axial direction by outer ring ribs and the inner ring is smooth as well as by single row cylindrical roller bearings in NU design. That is why these bearings cannot carry axial loads. Single row needle roller bearings have a small height of the cross section and relatively high basic load rating and are especially suitable for arrangements with limited space in radial direction. Bearings have a groove and lubrication holes on the outer ring periphery. Single row needle roller bearings are produced without cage. Bearings without cage (V) have a full complement of cylindrical rollers which results in higher load rating, but smaller limiting rotational speed in comparison with bearings of the same size with cage. Bearings are also delivered without inner ring (R NA). In this case the inner raceway is created directly on the journal.

## Boundary Dimensions

Boundary dimensions comply with the standard ISO 15 and are shown in the dimension tables of this publication.

## Designation

Bearing designation in standard design is in the dimension tables of this publication.

Difference from standard design is designated by additional symbols (section 2.2).

## Tolerance

Single row needle roller bearings are commonly produced in normal tolerance class P0 (symbol P0 is not indicated). For special arrangements demanding accuracy, bearings in higher tolerance class P6 are delivered. Delivery of these bearings should be discussed in advance. Limiting values of dimension and running accuracy are shown in table 10.

## Radial Clearance

Commonly produced single row needle roller bearings have normal radial clearance which is not indicated. For special arrangements bearings with greater radial clearance (C3) are delivered. Radial clearance values are shown in table 26.

## Bearings without Inner Rings

For arrangements with limited mounting space single row needle roller bearings without inner ring are delivered (R NA). Needle rollers of these bearings roll directly on the ground journal. Inner raceways diameter tolerances for single row needle roller bearings without inner ring are shown in following table.

Journal Diameter $F_w$	Radial Clearance		Greater		
	Smaller	Normal to 80 mm	over 80 mm	to 65 mm	over 65
mm					
Inner Raceway Diameter	k5	h5	g6	g6	f6
Tolerance					

Raceway deviations of roundness and cylindricity must not be greater than deviations for tolerance class IT3. Values of basic load ratings  $C_r$  and  $C_{or}$  shown in dimension tables are valid for bearings without inner ring if inner raceway hardness on the journal will be in the range 59 to 65 HRC. With decreasing raceway hardness also the load rating values decrease and the table value  $C_r$  should be multiplied by factor  $f_t$  (Table 7). Minimum depth of hardened layer after grinding should be 1 to 3 mm according to bearing dimension and load. Raceway surface roughness for common arrangements  $R_a = 0.2$ , for less demanding arrangements  $R_a = 0.4$ .

### Misalignment

Mutual ring misalignment of single row needle roller bearings is small. Permissible misalignment values are to 2'.

### Radial Equivalent Dynamic Load

$$P_r = F_r \quad [\text{kN}]$$

### Radial Equivalent Static Load

$$P_{or} = F_r \quad [\text{kN}]$$





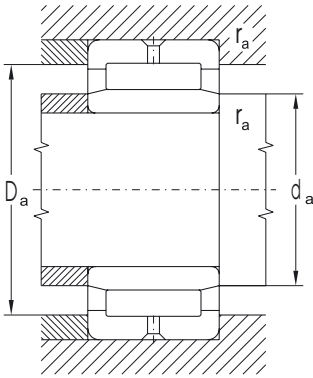

Abutment and Fillet Dimensions					Weight	
d	d <sub>a</sub> min	d <sub>a</sub> max	D <sub>a</sub> max	r <sub>a</sub> max	~ NA	R NA
mm					kg	
20	24.0	26.0	38.0	0.6	0.176	0.124
25	28.0	32.0	43.0	0.6	0.200	0.134
30	34.0	38.0	50.0	1.0	0.311	0.202
35	39.5	44.0	57.0	1.0	0.419	0.272
40	44.0	49.0	63.0	1.0	0.495	0.306
50	54.0	56.5	68.0	0.6	0.373	0.260
	54.0	59.0	75.0	1.0	0.687	0.440



# Double Row Spherical Roller Bearings

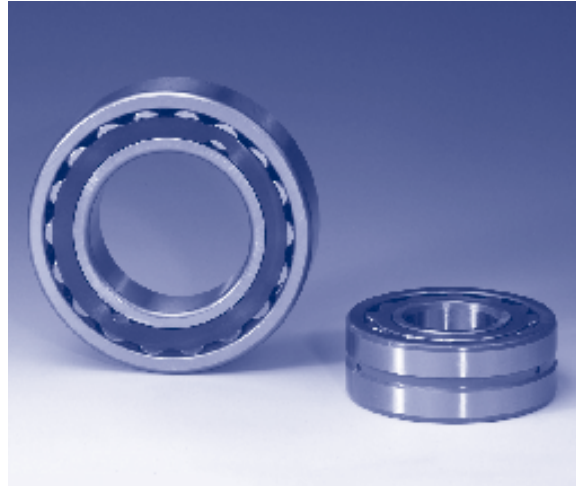

Double row spherical roller bearings have two rows of spherical rollers with a common sphered raceway in the outer ring. This design enables mutual misalignment of rings. They can

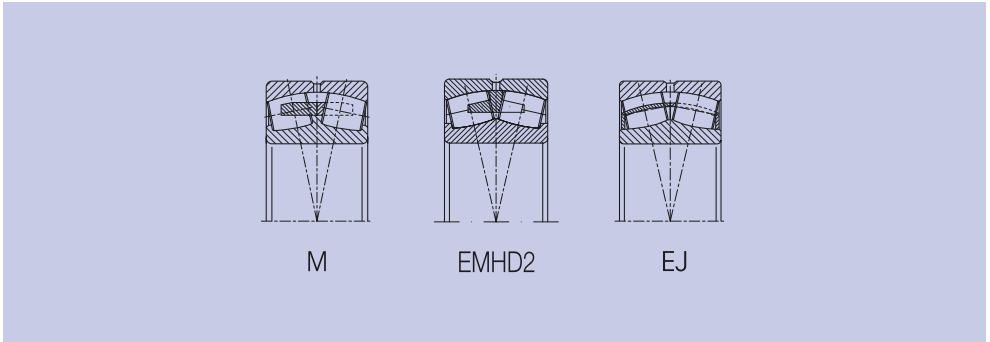

simultaneously carry great radial and axial load in both directions. These bearings are produced with both cylindrical and tapered bore. These bearings are suitable for arrangements where great loads are acting and misalignment should be secured.

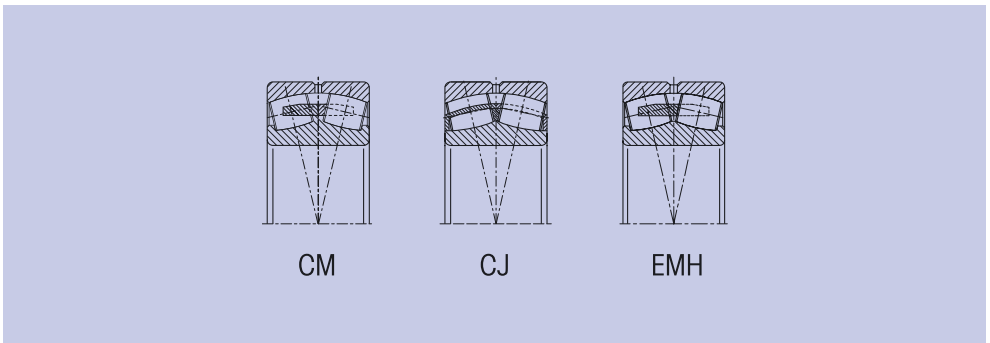

## Boundary Dimensions

Boundary dimensions comply with the standard ISO 15 and are shown in the dimension tables of this publication.

## Designation

Bearing designation in standard design and in design with tapered bore is in the dimension tables of this publication.

Difference from standard design is designated by additional symbols (section 2.2).

## Influence of operating temperature on bearing material

All spherical roller bearings goes through a special heat treatment, which allows their use in the operating temperature to 200 degrees without undesirable dimensional changes. Designation S1 isn't shown on the bearings.

## Tapered Bore

Bearings with tapered bore have taper 1:12, for type 240 the taper size is 1:30 (K30). Bearings with tapered bore are fixed on the cylindrical shafts by means of adapter sleeves. Sleeve designation corresponding to individual bearings is in the dimension tables of this publication.

## Lubrication Groove and Holes on Outer Ring

All types and sizes of double row spherical roller bearings are delivered besides the standard design also design W33 with groove and lubricating holes along the periphery that provides better lubricating and higher reliability.

## Cage

Bearings have cage material and design as shown in the dimension tables of this publication. Bearings with symbols J and E have pressed steel cage, bearings with symbol M have machined brass cage.

## Tolerance

Double row spherical roller bearings are commonly produced in normal tolerance class P0 which is not indicated. Bearing delivery with higher tolerance class should be discussed with the supplier in advance.

## Radial Clearance

Commonly produced bearings have normal radial clearance which is not indicated. For special arrangements bearings with smaller clearance C2 and greater radial clearance C3, C4 and C5 are delivered. Radial clearance values comply with standard ISO 5753 and are shown in table 27.

## Misalignment

Bearings can misalign from the central position without affecting their correct function. The following table shows permissible misalignment values according to bearing type.

Bearing Type	Permissible Misalignment
239, 230, 231, 222	1°30'
223	2°
232	2°30'
240	2°
241	2°30'

## Radial Equivalent Dynamic Load

$$P_r = F_r + Y_1 F_a \quad \text{for } F_a/F_r \leq e \quad [\text{kN}]$$

$$P_r = 0.67 F_r + Y_2 F_a \quad \text{for } F_a/F_r > e \quad [\text{kN}]$$

Factor values  $e$ ,  $Y_1$ , and  $Y_2$  for individual bearings are indicated in dimension tables of this publication.

## Radial Equivalent Static Load

$$P_{or} = F_r + Y_0 F_a \quad [\text{kN}]$$

Factor values  $Y_0$  for individual bearings are indicated in the dimensional tables of this publication.



# Double Row Spherical Roller Bearings

d = 25 to 90 mm

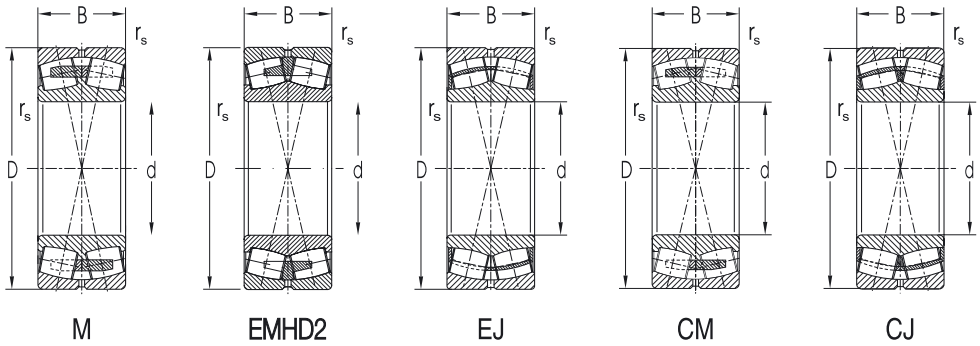

Dimensions				Basic Load Rating		Fatigue load limit	Limiting Speed for Lubrication with		Bearing Designation			
d	D	B	r <sub>s</sub>	a	b	P <sub>u</sub>	Grease	Oil	with Cylindrical Bore	with Tapered Bore		
mm				min		kN	min <sup>-1</sup>					
25	52	18,0	1,0	—	—	46	46,1	5,62	8500	11000	22205EW33J	22205EKW33J
30	62	20,0	1,0	—	—	61	64,5	7,87	7500	9500	22206EW33J	22206EKW33J
35	72	23,0	1,1	—	—	81	92	11,22	6300	8000	22207EW33J	22207EKW33J
40	80	23,0	1,1	2,5	5,4	93	105	12,80	6000	7500	22208EW33J	22208EKW33J
	90	33,0	1,5	3,0	5,5	140	160	19,51	4100	5100	22308EW33J	22308EKW33J
	90	33,0	1,5	3,0	5,5	140	160	19,51	4100	5100	22308EW33MH	22308EKW33MH
45	85	23,0	1,1	2,5	5,8	97	113	13,78	5300	6700	22209EW33J	22209EKW33J
	100	36,0	1,5	3,0	5,5	167	194	23,66	3700	4500	22309EW33J	22309EKW33J
	100	36,0	1,5	3,0	5,5	167	194	23,66	3700	4500	22309EW33MH	22309EKW33MH
50	90	23,0	1,1	2,5	5,8	105	124	15,12	5000	6300	22210EW33J	22210EKW33J
	110	40,0	2,0	3,0	5,5	200	238	29,02	3300	4000	22310EW33J	22310EKW33J
	110	40,0	2,0	3,0	5,5	200	238	29,02	3300	4000	22310EW33MH	22310EKW33MH
55	100	25,0	1,5	3,0	5,5	125	147	17,93	4500	5600	22211EW33J	22211EKW33J
	120	43,0	2,0	3,0	5,5	230	279	34,02	3000	3800	22311EW33J	22311EKW33J
	120	43,0	2,0	3,0	5,5	230	279	34,02	3000	3800	22311EW33MH	22311EKW33MH
60	110	28,0	1,5	3,0	5,5	152	183	22,32	4000	5000	22212EW33J	22212EKW33J
	130	46,0	2,1	3,0	5,5	273	315	38,41	2800	3600	22312EW33J	22312EKW33J
	130	46,0	2,1	3,0	5,5	273	315	38,41	2800	3600	22312EMHD2	22312EKMH2
	130	46,0	2,1	3,0	5,5	304	315	38,41	2800	3600	22312EW33MH**	22312EKW33MH
	130	46,0	2,1	3,0	5,5	209	230	28,05	2800	3300	22312W33M*	22312KW33M
65	120	31,0	1,5	3,0	5,5	182	224	27,32	3800	4800	22213EW33J	22213EKW33J
	140	48,0	2,1	3,0	5,5	304	351	42,49	2600	3400	22313EW33J	22313EKW33J
	140	48,0	2,1	3,0	5,5	304	351	42,49	2600	3400	22313EMHD2	22313EKMH2
	140	48,0	2,1	3,0	5,5	222	252	30,50	2500	3200	22313W33M*	22313KW33M
70	125	31,0	1,5	3,0	5,5	189	239	29,15	3600	4500	22214EW33J	22214EKW33J
	150	51,0	2,1	3,0	5,5	344	402	47,64	2400	3100	22314EW33J	22314EKW33J
	150	51,0	2,1	3,0	5,5	344	402	47,64	2400	3100	22314EMHD2	22314EKMH2
	150	51,0	2,1	3,0	5,5	383	402	47,64	2400	3100	22314EW33MH**	22314EKW33MH
	150	51,0	2,1	3,0	5,5	289	330	39,11	2400	3000	22314W33M*	22314KW33M
75	130	31,0	1,5	3,0	5,5	196	255	30,87	3400	4300	22215EW33J	22215EKW33J
	160	55,0	2,1	4,5	8,3	396	489	56,82	2300	3000	22315EW33J	22315EKW33J
	160	55,0	2,1	4,5	8,3	396	489	56,82	2300	3000	22315EMHD2	22315EKMH2
80	160	55,0	2,1	4,5	8,3	295	354	41,13	2200	2800	22315W33M*	22315KW33M
	140	33,0	2,0	3,0	5,5	224	295	34,96	3200	4000	22216EW33J	22216EKW33J
	140	33,0	2,0	3,0	5,5	154	197	23,35	2400	3000	22216W33M*	22216KW33M
	170	58,0	2,1	4,5	8,3	443	551	62,84	2200	2800	22316EW33J	22316EKW33J
	170	58,0	2,1	4,5	8,3	443	551	62,84	2200	2800	22316EMHD2	22316EKMH2
85	170	58,0	2,1	4,5	8,3	349	411	46,88	2200	2800	22316W33M*	22316KW33M
	150	36,0	2,0	3,0	5,5	260	337	39,16	3000	3800	22217EW33J	22217EKW33J
	150	36,0	2,0	3,0	5,5	171	214	24,87	2200	2800	22217W33M*	22217KW33M
	180	60,0	3,0	4,5	8,3	482	603	67,58	2000	2600	22317EW33J	22317EKW33J
	180	60,0	3,0	4,5	8,3	482	603	67,58	2000	2600	22317EMHD2	22317EKMH2
90	180	60,0	3,0	4,5	8,3	377	447	50,10	2000	2500	22317W33M*	22317KW33M
	160	40,0	2,0	4,5	8,3	308	406	46,31	2600	3400	22218EW33J	22218EKW33J
	160	40,0	2,0	4,5	8,3	209	265	30,22	2000	2500	22218W33M*	22218KW33M
	160	52,4	2,0	3,0	5,5	303	412	46,99	1900	2400	23218W33M	23218KW33M

Deliveries of bearings marked with \* must be agreed with the producer.

\*\* Bearings in the new standard NEW FORCE (see the catalogue NEW FORCE)



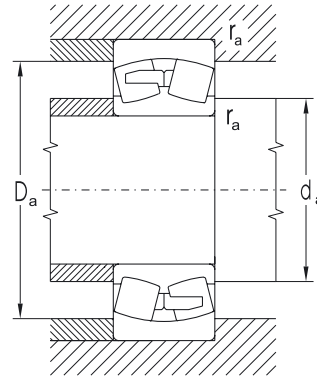
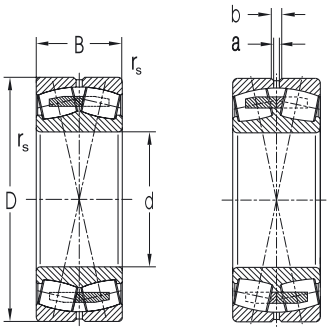

### EMH

Abutment and Fillet Dimensions				Weight		Corresp. Adapter Sleeve	Corresp. Withdrawal Sleeve	Corresp. Nut	Factors			
d	d <sub>a</sub> min	D <sub>a</sub> max	r <sub>a</sub> max	K					e	Y <sub>1</sub>	Y <sub>2</sub>	Y <sub>0</sub>
mm				kg								
25	31	46	1,0	0,16	0,155	H305	AH305	KM6	0,34	2,0	3,0	2,0
30	36	56	1,0	0,25	0,245	H306	AH306	KM7	0,31	2,1	3,2	2,1
35	42	65	1,0	0,42	0,410	H307	AH307	KM8	0,31	2,2	3,3	2,1
40	47	73	1,0	0,51	0,500	H308	AH308	KM9	0,27	2,5	3,7	2,4
	49	81	1,5	1,05	1,030	H2308	AH2308	KM9	0,36	1,8	2,6	1,8
45	49	81	1,5	1,07	1,050	H2308	AH2308	KM9	0,36	1,8	2,6	1,8
	52	78	1,0	0,55	0,530	H309	AH309	KM10	0,26	2,6	3,9	2,6
50	54	91	1,5	1,40	1,370	H2309	AH2309	KM10	0,36	1,9	2,8	1,9
	54	91	1,5	1,43	1,400	H2309	AH2309	KM10	0,36	1,9	2,8	1,9
55	57	83	1,0	0,59	0,570	H310	AH310X	KM11	0,24	2,8	4,2	2,8
	60	100	2,0	1,87	1,830	H2310	AH2310X	KM11	0,36	1,9	2,7	1,8
60	60	100	2,0	1,92	1,880	H2310	AH2310X	KM11	0,36	1,9	2,7	1,8
	64	91	1,5	0,83	0,820	H311	AH311X	KM12	0,23	2,9	4,4	2,9
65	65	110	2,0	2,36	2,310	H2311	AH2311X	KM12	0,35	1,9	2,8	1,9
	65	110	2,0	2,44	2,390	H2311	AH2311X	KM12	0,35	1,9	2,8	1,9
70	69	101	1,5	1,14	1,120	H312	AH312X	KM13	0,24	2,8	4,2	2,8
	72	118	2,0	2,91	2,840	H2312	AH2312X	KM13	0,35	1,9	2,9	1,9
75	72	118	2,0	3,03	2,970	H2312	AH2312X	KM13	0,35	1,9	2,9	1,9
	72	118	2,0	2,95	2,880	H2312	AH2312X	KM13	0,35	1,9	2,9	1,9
80	72	118	2,0	3,00	2,900	H2312	AH2312X	KM13	0,41	1,6	2,4	1,6
	74	111	1,5	1,51	1,480	H313	AH313	KM15	0,24	2,9	4,2	2,8
85	77	128	2,0	3,46	3,380	H2313	AH2313	KM15	0,34	2,0	3,0	2,0
	77	128	2,0	3,64	3,560	H2313	AH2313	KM15	0,34	2,0	3,0	2,0
90	77	128	2,0	3,60	3,500	H2313	AH2313	KM15	0,38	1,8	2,5	1,7
	79	116	1,5	1,61	1,570	H314	AH314	KM16	0,23	2,9	4,2	2,8
95	82	138	2,0	4,19	4,100	H2314	AH2314X	KM16	0,34	2,0	3,0	2,0
	82	138	2,0	4,40	4,310	H2314	AH2314X	KM16	0,34	2,0	3,0	2,0
100	82	138	2,0	4,38	4,290	H2314	AH2314X	KM16	0,34	2,0	3,0	2,0
	82	138	2,0	4,30	4,200	H2314	AH2314X	KM16	0,37	1,8	2,6	1,7
105	84	121	1,5	1,70	1,660	H315	AH315	KM17	0,22	3,1	4,5	2,9
	87	148	2,0	5,27	5,150	H2315	AH2315X	KM17	0,33	2,0	3,0	2,0
110	87	148	2,0	5,48	5,360	H2315	AH2315X	KM17	0,33	2,0	3,0	2,0
	87	148	2,0	5,40	5,200	H2315	AH2315X	KM17	0,38	1,8	2,5	1,7
115	90	130	2,0	2,11	2,070	H316	AH316	KM18	0,22	3,1	4,5	3,0
	90	130	2,0	2,20	2,100	H316	AH316	KM18	0,26	2,6	3,8	2,5
120	92	158	2,0	6,25	6,110	H2316	AH2316X	KM18	0,33	2,0	3,0	2,0
	92	158	2,0	6,51	6,370	H2316	AH2316X	KM18	0,33	2,0	3,0	2,0
125	92	158	2,0	6,30	6,200	H2316	AH2316X	KM18	0,36	1,8	2,7	1,8
	95	140	2,0	2,66	2,610	H317	AH317X	KM19	0,22	3,0	4,4	2,9
130	95	140	2,5	2,80	2,700	H317	AH317X	KM19	0,26	2,6	3,7	2,5
	99	166	2,5	7,16	7,010	H2317	AH2317X	KM19	0,32	2,1	3,1	2,0
135	99	166	2,5	7,48	7,340	H2317	AH2317X	KM19	0,32	2,1	3,1	2,0
	99	166	2,5	7,40	7,200	H2317	AH2317X	KM19	0,36	1,9	2,7	1,8
140	100	150	2,0	3,40	3,330	H318	AH318X	KM20	0,23	2,9	4,2	2,8
	100	150	2,0	3,60	3,400	H318	AH318X	KM20	0,26	2,6	3,7	2,4
145	100	150	2,0	4,70	4,600	H2318	AH3218X	KM20	0,33	2,0	3,0	1,9



# Double Row Spherical Roller Bearings

d = 90 to 120 mm

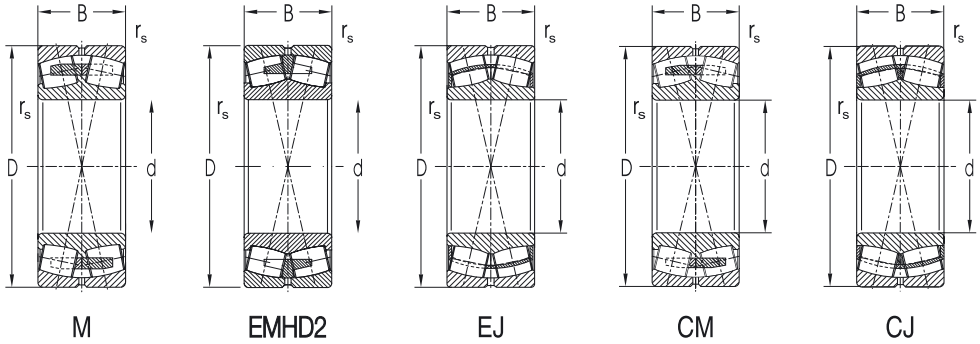

Dimensions					Basic Load Rating		Fatigue load limit	Limiting Speed for Lubrication with		Bearing Designation		
d	D	B	r <sub>s</sub>	a	b	Dyn. C <sub>r</sub>	Stat. C <sub>or</sub>	P <sub>0</sub>	Grease	Oil	with Cylindrical Bore	with Tapered Bore
mm					kN		kN	min <sup>-1</sup>				
90	160	52,4	2,0	3,0	5,5	370	522	59,54	1900	2600	23218CW33J	23218CKW33J
	190	64,0	3,0	4,5	8,3	536	673	74,19	1900	2400	22318EW33J	22318EKW33J
	190	64,0	3,0	4,5	8,3	536	673	74,19	1900	2400	22318EMHD2	22318EKMHD2
	190	64,0	3,0	4,5	8,3	437	522	57,55	1900	2400	22318W33M*	22318KW33M
95	170	43,0	2,1	4,5	8,3	346	464	52,00	2400	3200	22219EW33J	22219EKW33J
	170	43,0	2,1	4,5	8,3	259	329	36,87	2000	2500	22219W33M	22219KW33M
	200	67,0	3,0	4,5	8,3	473	566	61,43	1800	2200	22319W33M*	22319KW33M
	200	67,0	3,0	4,5	8,3	587	744	80,75	1800	2300	22319EW33J	22319EKW33J
100	200	67,0	3,0	4,5	8,3	587	744	80,75	1800	2300	22319EMHD2	22319EMHD2
	165	52,0	2,0	3,0	5,5	379	587	65,79	2000	2800	23120CW33J	23120CKW33J
	180	46,0	2,1	4,5	8,3	379	510	64,19	2200	3000	22220EW33J	22220EKW33J
	180	46,0	2,1	4,5	8,3	290	375	47,20	1900	2400	22220W33M*	22220KW33M
	180	60,3	2,1	4,5	8,3	465	667	83,95	1700	2200	23220CW33J	23220CKW33J
	180	60,3	2,1	4,5	8,3	390	532	66,96	1700	2000	23220W33M	23220KW33M
110	215	73,0	3,0	4,5	8,3	682	842	100,48	1700	2200	22320EW33J	22320EKW33J
	215	73,0	3,0	4,5	8,3	563	686	81,86	1700	2000	22320W33M*	22320KW33M
	170	60,0	2,0	3,0	5,5	402	717	79,04	1800	2200	24022CW33J	24022CK30W33J
	170	45,0	2,0	3,0	5,5	329	516	56,88	2200	3000	23022CW33J	23022CKW33J
	170	45,0	2,0	3,0	5,5	362	516	56,88	2200	3000	23022EW33MH**	23022EKW33MH
	180	56,0	2,0	4,5	8,3	374	585	63,82	1900	2600	23122CW33J	23122CKW33J
	180	56,0	2,0	4,5	8,3	354	541	59,02	1700	2000	23122W33M*	23122KW33M
	180	69,0	2,0	3,0	5,5	501	849	92,62	1000	1400	24122CW33J	24122CK30W33J
	200	53,0	2,1	4,5	8,3	488	653	69,82	2000	2800	22222EW33J	22222EKW33J
	200	53,0	2,1	4,5	8,3	365	474	50,68	1700	2000	22222W33M*	22222KW33M
120	200	69,8	2,1	4,5	8,3	586	867	92,71	1600	2000	23222CW33J	23222CKW33J
	200	69,8	2,1	4,5	8,3	502	706	75,49	1500	1800	23222W33M	23222KW33M
	240	80,0	3,0	6,0	11,1	805	1000	103,10	1500	1900	22322EW33J	22322EKW33J
	240	80,0	3,0	6,0	11,1	662	801	82,59	1500	1800	22322W33M*	22322KW33M
	180	46,0	2,0	3,0	5,5	346	572	61,77	2000	2800	23024CW33J	23024CKW33J
	180	46,0	2,0	3,0	5,5	287	467	50,43	1600	1900	23024W33M	23024KW33M
	180	60,0	2,0	3,0	5,5	413	770	83,15	1600	2000	24024CW33J	24024CK30W33J
	200	62	2,0	4,5	8,3	523	798	84,52	1800	2400	23124CW33J	23124CKW33J
	200	62,0	2,0	4,5	8,3	430	648	68,63	1500	1800	23124W33M	23124KW33M
	200	80,0	2,0	3,0	5,5	639	1080	114,39	950	1300	24124CW33J	24124CK30W33J
	215	58,0	2,1	4,5	8,3	553	775	80,96	1900	2600	22224EW33J	22224EKW33J
	215	58,0	2,1	4,5	8,3	439	580	60,59	1600	1900	22224W33M*	22224KW33M
	215	76,0	2,1	4,5	8,3	678	1020	106,56	1500	1900	23224CW33J	23224CKW33J
	215	76,0	2,1	4,5	8,3	750	1020	106,56	1500	1900	23224EW33MH**	23224EKW33MH
215	76,0	2,1	4,5	8,3	564	803	83,89	1400	1700	23224W33M*	23224KW33M	
260	86,0	3,0	6,0	11,1	782	962	96,77	1400	1700	22324W33M*	22324KW33M	
260	86,0	3,0	6,0	11,1	938	1180	118,70	1400	1800	22324EW33J	22324EKW33J	
130	200	52,0	2,0	4,5	8,3	444	711	74,61	1900	2600	23026CW33J	23026CKW33J
	200	52,0	2,0	3,0	5,5	367	579	60,76	1500	1800	23026W33M	23026KW33M
	200	69,0	2,0	4,5	8,3	539	978	102,63	1500	1900	24026CW33J	24026CK30W33J
	210	64,0	2,0	4,5	8,3	474	752	78,21	1400	1700	23126W33M*	23126KW33M
	210	64,0	2,0	4,5	8,3	561	913	94,96	1700	2200	23126CW33J	23126CKW33J

Deliveries of bearings marked with \* must be agreed with the producer.

\*\* Bearings in the new standard NEW FORCE (see the catalogue NEW FORCE)

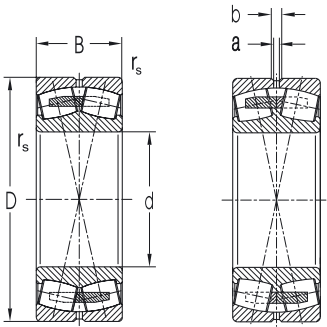

EMH

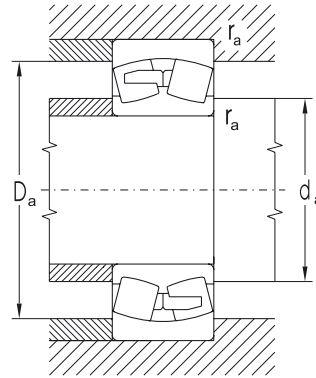

Abutment and Fillet Dimensions				Weight		Corresp. Adapter Sleeve	Corresp. Withdrawal Sleeve	Corresp. Nut	Factors				
d	d <sub>a</sub> min	D <sub>a</sub> max	r <sub>a</sub> max	K					e	Y <sub>1</sub>	Y <sub>2</sub>	Y <sub>0</sub>	
mm				kg									
90	100	150	2,0	4,52	4,400	H2318	AH3218X	KM20	0,31	2,2	3,3	2,2	
	104	176	2,5	8,54	8,350	H2318	AH2318X	KM20	0,33	2,1	3,1	2,0	
	104	176	2,5	8,89	8,700	H2318	AH2318X	KM20	0,33	2,1	3,1	2,0	
	104	176	2,5	8,80	8,600	H2318	AH2318X	KM20	0,37	1,8	2,6	1,7	
95	107	158	2,0	4,17	4,080	H319	AH319X	KM21	0,23	2,9	4,2	2,7	
	107	158	2,0	4,40	4,300	H319	AH319X	KM21	0,26	2,5	3,6	2,4	
	109	186	2,5	10,30	10,100	H2319	AH2319	KM21	0,37	1,8	2,6	1,7	
	109	186	2,5	9,86	9,640	H2319	AH2319	KM21	0,33	2,1	3,1	2,0	
	109	186	2,5	10,30	10,000	H2319	AH2319	KM21	0,33	2,1	3,1	2,0	
100	110	155	2,0	4,40	4,260	H3120	AH3120X	KM22	0,29	2,4	3,5	2,3	
	112	168	2,0	5,01	4,900	H320	AH320X	KM22	0,24	2,9	4,1	2,7	
	112	168	2,0	5,30	5,200	H320	AH320X	KM22	0,27	2,5	3,6	2,4	
	112	168	2,0	6,67	6,490	H2320	AH3220X	KM22	0,31	2,2	3,2	2,1	
	112	168	2,0	6,90	6,700	H2320	AH3220X	KM22	0,34	2,0	2,8	1,9	
	114	201	2,5	12,30	12,100	H2320	AH2320X	KM22	0,33	2,0	3,0	2,0	
	114	201	2,5	13,00	12,700	H2320	AH2320X	KM22	0,37	1,8	2,6	1,7	
	110	120	160	2,0	5,04	4,950	—	—	—	0,32	2,1	3,2	2,1
110	120	160	2,0	3,68	3,560	H322	AH3122X	KM24	0,24	2,9	4,3	2,8	
	120	160	2,0	3,73	3,610	H322	AH3122X	KM24	0,24	2,9	4,3	2,8	
	120	170	2,0	5,36	5,190	H3122	AH3122X	KM24	0,30	2,3	3,4	2,2	
	120	170	2,0	6,00	5,800	H3122	AH3122X	KM24	0,31	2,2	3,1	2,1	
	120	170	2,0	6,94	6,830	—	AH24122	KM23	0,35	1,9	2,8	1,9	
	122	188	2,0	7,09	6,940	H3222	AH3120X	KM24	0,25	2,7	4,0	2,6	
	122	188	2,0	7,50	7,400	H3222	AH3120X	KM24	0,27	2,4	3,5	2,3	
	122	188	2,0	9,65	9,380	H2322	AH3222X	KM25	0,33	2,1	3,1	2,0	
	122	188	2,0	9,90	9,600	H2322	AH3222X	KM25	0,36	1,9	2,7	1,8	
	124	226	2,5	17,20	16,800	H2322	AH2322X	KM25	0,33	2,1	3,1	2,0	
	124	226	2,5	18,20	17,900	H2322	AH2322X	KM25	0,36	1,8	2,6	1,7	
	120	130	170	2,0	4,04	3,910	H3024	AH3024X	KM26	0,23	3,0	4,5	2,9
		130	170	2,0	4,30	4,200	H3024	AH3024X	KM26	0,24	2,7	4,2	2,6
		130	170	2,0	5,35	5,260	—	AH24024	KM25	0,30	2,3	3,4	2,2
130		190	2,0	7,69	7,450	H3124	AH3124X	KM26	0,28	2,4	3,5	2,3	
130		190	2,0	8,20	8,000	H3124	AH3124X	KM26	0,31	2,1	3,1	2,0	
130		190	2,0	10,10	9,900	—	AH24124	KM26	0,37	1,8	2,7	1,8	
132		203	2,0	8,96	8,760	H3124	AH3124X	KM26	0,25	2,7	3,9	2,5	
132		203	2,0	9,40	9,200	H3124	AH3124X	KM26	0,28	2,4	3,4	2,3	
132		203	2,0	11,80	11,500	H2324	AH3224X	KM27	0,33	2,0	3,0	2,0	
132		203	2,0	12,10	11,800	H2324	AH3224X	KM27	0,33	2,0	3,0	2,0	
132		203	2,0	12,30	11,900	H2324	AH3224X	KM27	0,36	1,9	2,7	1,8	
134		246	2,5	22,10	21,600	H2324	AH2324X	KM27	0,36	1,9	2,7	1,8	
134		246	2,5	21,50	21,100	H2324	AH2324X	KM27	0,33	2,1	3,1	2,0	
130		140	190	2,0	5,85	5,670	H3026	AH3026X	KM28	0,23	2,9	4,3	2,9
	140	190	2,0	6,30	6,100	H3026	AH3026X	KM28	0,26	2,6	3,8	2,5	
	140	190	2,0	7,92	7,790	—	AH24026	KM27	0,31	2,2	3,2	2,1	
	140	200	2,0	9,10	8,800	H3126	AH3126X	KM28	0,30	2,2	3,2	2,1	
	140	200	2,0	8,47	8,200	H3126	AH3126X	KM28	0,28	2,4	3,6	2,4	



# Double Row Spherical Roller Bearings

d = 130 to 160 mm

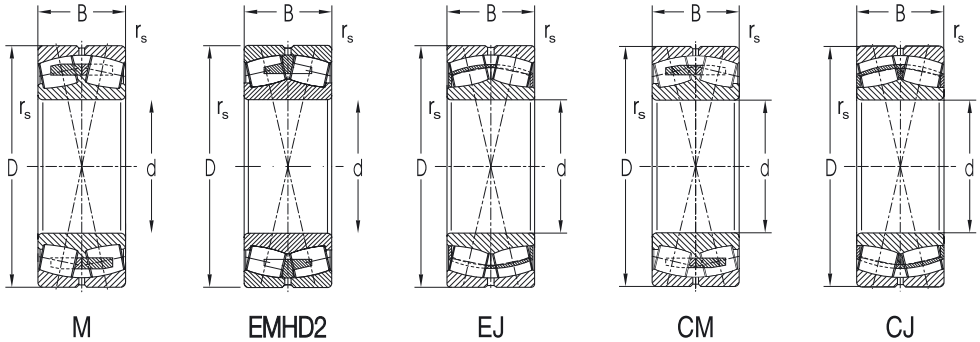

Dimensions				Basic Load Rating		Fatigue load limit	Limiting Speed for Lubrication with		Bearing Designation				
d	D	B	r <sub>s</sub>	a	b	P <sub>u</sub>	Grease	Oil	with Cylindrical Bore	with Tapered Bore			
mm						kN	min <sup>-1</sup>						
130	210	64,0	2,0	4,5	8,3	620	913	94,96	1700	2200	23126EW33MH**	23126EKW33MH	
	210	80,0	2,0	3,0	5,5	657	1160	120,65	900	1200	24126CW33J	24126CK30W33J	
	230	64,0	3,0	6,0	11,1	641	948	96,92	1800	2400	22226EW33J	22226EKW33J	
	230	64,0	3,0	6,0	11,1	708	948	96,92	1800	2400	22226EW33MH**	22226EKW33MH	
	230	64,0	3,0	6,0	11,1	525	726	74,22	1500	1800	22226W33M*	22226KW33M	
	230	80,0	3,0	6,0	11,1	636	948	96,92	1300	1600	23226W33M	23226KW33M*	
	230	80,0	3,0	4,5	8,3	753	1180	120,64	1300	1700	23226CW33J	23226CKW33J	
	280	93,0	4,0	7,5	13,9	904	1130	111,11	1300	1600	22326W33M*	22326KW33M	
	280	93,0	4,0	7,5	13,9	1090	1380	135,69	1300	1700	22326EW33J	22326EKW33J	
	140	210	53,0	2,0	4,5	8,3	380	633	65,26	1400	1700	23028W33M	23028KW33M
210		53,0	2,0	4,5	8,3	463	781	80,52	1800	2400	23028CW33J	23028CKW33J	
210		53,0	2,0	4,5	8,3	511	781	80,52	1800	2400	23028EW33MH**	23028EKW33MH	
210		69,0	2,0	4,5	8,3	549	1040	107,23	1400	1800	24028CW33J	24028CK30W33J	
225		68,0	2,1	4,5	8,3	540	865	88,07	1300	1600	23128W33M	23128KW33M	
225		68,0	2,1	4,5	8,3	629	1030	104,87	1600	2000	23128CW33J	23128CKW33J	
225		85,0	2,1	4,5	8,3	740	1330	135,41	850	1100	24128CW33J	24128CK30W33J	
250		68,0	3,0	6,0	11,1	747	1080	107,80	1700	2200	22228W33M*	22228EKW33J	
250		68,0	3,0	6,0	11,1	605	822	82,04	1400	1700	22228W33M*	22228KW33M	
250		88,0	3,0	6,0	11,1	895	1370	136,74	1200	1600	23228CW33J	23228CKW33J	
250		88,0	3,0	6,0	11,1	815	1320	131,75	1200	1600	23228CW33M	23228CKW33M	
300		102,0	4,0	7,5	13,9	1220	1560	150,17	1200	1500	22328CW33J	22328CKW33J	
300		102,0	4,0	7,5	13,9	993	1270	122,25	1200	1500	22328W33M	22328KW33M	
150		225	56,0	2,1	4,5	8,3	517	881	88,97	1700	2200	23030CW33J	23030CKW33J
		225	56,0	2,1	4,5	8,3	573	881	88,97	1700	2200	23030EW33MH**	23030EKW33MH
		225	56,0	2,1	4,5	8,3	419	697	70,39	1300	1600	23030W33M*	23030KW33M
	225	75,0	2,1	3,0	5,5	635	1220	123,21	1300	1700	24030CW33J	24030CK30W33J	
	250	80,0	2,1	4,5	8,3	711	1130	111,93	1200	1500	23130W33M	23130KW33M	
	250	80,0	2,1	6,0	11,1	823	1310	129,76	1400	1800	23130CW33J	23130CKW33J	
	250	100,0	2,1	4,5	8,3	968	1690	167,40	800	1000	24130CW33J	24130CK30W33J	
	270	73,0	3,0	7,5	13,9	863	1260	123,00	1600	2000	22230EW33J	22230EKW33J	
	270	73,0	3,0	7,5	13,9	668	920	89,81	1300	1600	22230W33M*	22230KW33M	
	270	96,0	3,0	6,0	11,1	1040	1620	158,14	1100	1500	23230CW33J	23230CKW33J	
	270	96,0	3,0	7,5	13,9	874	1300	126,90	1100	1400	23230W33M	23230KW33M	
	320	108,0	4,0	9,0	16,7	1370	1850	174,60	1000	1400	22330CW33J	22330CKW33J	
	320	108,0	4,0	9,0	16,7	1190	1610	151,95	1000	1400	22330CW33M	22330CKW33M	
	160	240	60,0	2,1	6,0	11,1	587	1010	100,05	1700	2200	23032CW33J	23032CKW33J
240		60,0	2,1	6,0	11,1	521	903	89,45	1200	1500	23032W33M	23032KW33M	
240		80,0	2,1	4,5	8,3	719	1400	138,68	1100	1500	24032CW33J	24032CK30W33J	
270		86,0	2,1	6,0	11,1	817	1310	126,98	1100	1400	23132W33M	23132KW33M	
270		86,0	2,1	6,0	11,1	950	1480	143,46	1100	1400	23132CW33J	23132CKW33J	
270		109,0	2,1	4,5	8,3	1120	1980	191,92	700	900	24132CW33J	24132CK30W33J	
290		80,0	3,0	7,5	13,9	978	1440	137,69	1500	1900	22232EW33J	22232EKW33J	
290		80,0	3,0	7,5	13,9	839	1190	113,78	1200	1500	22232W33M*	22232KW33M	
290		104,0	3,0	7,5	13,9	1150	1840	175,93	1000	1400	23232CW33J	23232CKW33J	
290		104,0	3,0	7,5	13,9	1130	1830	174,98	1000	1400	23232CW33M	23232CKW33M	
340		114,0	4,0	9,0	16,7	1530	2090	193,62	1000	1300	22332CW33J	22332CKW33J	

Deliveries of bearings marked with \* must be agreed with the producer.

\*\* Bearings in the new standard NEW FORCE (see the catalogue NEW FORCE)

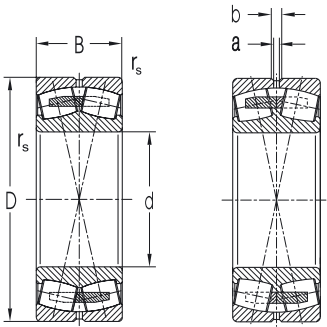

EMH

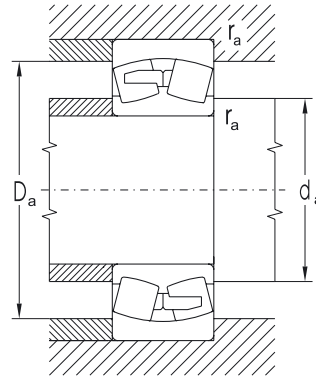

Abutment and Fillet Dimensions				Weight		Corresp. Adapter Sleeve	Corresp. Withdrawal Sleeve	Corresp. Nut	Factors			
d	d <sub>a</sub> min	D <sub>a</sub> max	r <sub>a</sub> max	K					e	Y <sub>1</sub>	Y <sub>2</sub>	Y <sub>0</sub>
mm				kg								
130	140	200	2,0	8,63	8,360	H3126	AH3126X	KM28	0,28	2,4	3,6	2,4
	140	200	2,0	10,90	10,700	—	AH24126	KM28	0,35	1,9	2,9	1,9
	144	216	2,5	11,20	11,000	H3126	AH3126X	KM28	0,26	2,6	3,8	2,5
	144	216	2,5	11,60	11,300	H3126	AH3126X	KM28	0,26	2,6	3,8	2,5
	144	216	2,5	11,80	11,700	H3126	AH3126X	KM28	0,29	2,3	3,3	2,2
	144	216	2,5	15,00	14,400	H2326	AH3226X	KM29	0,35	1,9	2,7	1,8
	144	216	2,5	13,90	13,500	H2326	AH3226X	KM29	0,33	2,1	3,1	2,0
	148	262	3,0	28,60	28,000	H2326	AH2326X	KM29	0,36	1,8	2,7	1,8
	148	262	3,0	26,80	26,200	H2326	AH2326X	KM29	0,33	2,1	3,1	2,0
140	150	200	2,0	6,90	6,700	H3028	AH3028X	KM30	0,24	2,7	4,2	2,6
	150	200	2,0	6,36	6,160	H3028	AH3028X	KM30	0,22	3,0	4,5	3,0
	150	200	2,0	6,58	6,380	H3028	AH3028X	KM30	0,22	3,0	4,5	3,0
	150	200	2,0	8,52	8,380	—	AH24028	KM29	0,29	2,3	3,4	2,3
	152	213	2,0	10,80	10,500	H3128	AH3128X	KM30	0,30	2,2	3,2	2,1
	152	213	2,0	10,30	10,000	H3128	AH3128X	KM30	0,27	2,5	3,7	2,4
	152	213	2,0	13,10	12,900	—	AH24128	KM30	0,35	1,9	2,9	1,9
	154	236	2,5	14,10	13,800	H3128	AH3128X	KM30	0,25	2,7	3,9	2,5
	154	236	2,5	15,00	14,600	H3128	AH3128X	KM30	0,28	2,4	3,4	2,2
	154	236	2,5	18,40	17,800	H2328	AH3228X	KM31	0,33	2,0	3,0	2,0
	154	236	2,5	18,60	18,000	H2328	AH3228X	KM31	0,33	2,0	3,0	2,0
	158	282	3,0	33,30	32,600	H2328	AH2328X	KM31	0,34	2,0	3,0	2,0
158	282	3,0	35,60	34,800	H2328	AH2328X	KM31	0,38	1,8	2,5	1,7	
150	162	213	2,0	7,74	7,500	H3030	AH3030X	KM32	0,22	3,1	4,6	3,0
	162	213	2,0	7,99	7,750	H3030	AH3030X	KM32	0,22	3,1	4,6	3,0
	162	213	2,0	8,30	8,000	H3030	AH3030X	KM32	0,24	2,7	4,2	2,6
	162	213	2,0	10,70	10,500	—	AH24030	KM31	0,30	2,3	3,4	2,2
	162	238	2,0	16,60	16,100	H3130	AH3130X	KM33	0,32	2,1	3,0	2,0
	162	238	2,0	15,50	15,000	H3130	AH3130X	KM33	0,29	2,3	3,4	2,3
	162	238	2,0	19,90	19,600	—	AH24130	KM32	0,37	1,8	2,7	1,8
	164	256	2,5	17,90	17,500	H3130	AH3130X	KM33	0,25	2,7	3,9	2,5
	164	256	2,5	18,60	18,200	H3130	AH3130X	KM33	0,28	2,3	3,4	2,2
	164	256	2,5	23,30	22,600	H2330	AH3230X	KM33	0,33	2,0	3,0	2,0
	164	256	2,5	24,60	23,900	H2330	AH3230X	KM33	0,36	1,8	2,7	1,8
	168	302	3,0	40,30	39,500	H2330	AH2330X	KM33	0,33	2,0	3,0	2,0
	168	302	3,0	41,70	40,800	H2330	AH2330X	KM33	0,37	1,8	2,7	1,8
	160	172	228	2,0	9,40	9,100	H3032	AH3032	KM34	0,22	3,1	4,6
172		228	2,0	10,30	10,000	H3032	AH3032	KM34	0,24	2,8	4,0	2,6
172		228	2,0	12,90	12,700	—	AH24032	KM34	0,30	2,3	3,4	2,2
172		258	2,0	21,30	20,700	H3132	AH3132	KM36	0,32	2,1	3,0	2,0
172		258	2,0	19,40	18,800	H3132	AH3132	KM36	0,32	2,1	3,0	2,0
172		258	2,0	25,70	25,300	—	AH24132	KM34	0,38	1,8	2,7	1,8
174		276	2,5	22,70	22,200	H3132	AH3132	KM36	0,26	2,6	3,8	2,5
174		276	2,5	24,40	23,900	H3132	AH3132	KM36	0,29	2,3	3,3	2,2
174		276	2,5	30,30	29,400	H2332	AH3232	KM36	0,34	2,0	2,9	1,9
174		276	2,5	31,00	30,100	H2332	AH3232	KM36	0,36	1,9	2,8	1,8
178		322	3,0	49,50	48,500	H2332	AH2332	KM36	0,33	2,0	3,0	2,0



# Double Row Spherical Roller Bearings

d = 160 to 200 mm

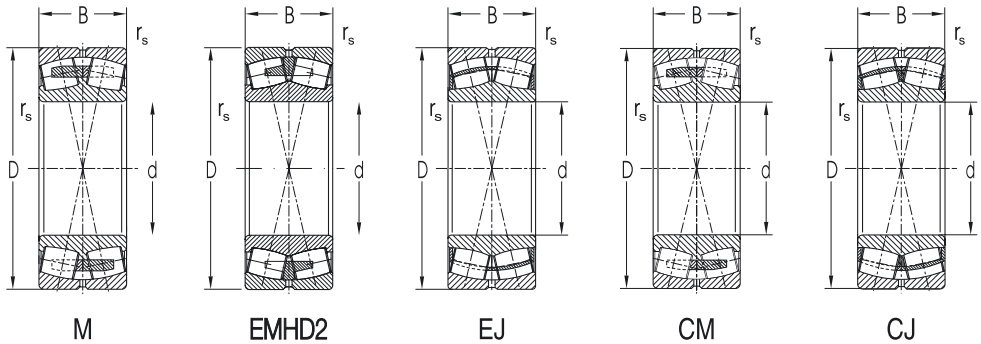

Dimensions						Basic Load Rating		Fatigue load limit	Limiting Speed for Lubrication with		Bearing Designation		
d	D	B	r <sub>s</sub>	a	b	Dyn. C <sub>r</sub>	Stat. C <sub>or</sub>	P <sub>u</sub>	Grease	Oil	with Cylindrical Bore	with Tapered Bore	
mm						kN		kN	min <sup>-1</sup>				
160	340	114,0	4,0	9,0	16,7	1250	1680	155,64	1000	1300	22332W33M	22332KW33M	
	170	260	67,0	2,1	6,0	11,1	701	1190	115,35	1600	2000	23034CW33J	23034CKW33J
		260	67,0	2,1	6,0	11,1	618	1050	101,78	1100	1400	23034W33M	23034KW33M
		260	90,0	2,1	4,5	8,3	875	1660	160,90	1000	1400	24034CW33J	24034CK30W33J
		280	88,0	2,1	6,0	11,1	826	1350	129,08	1000	1300	23134W33M	23134KW33M
		280	88,0	2,1	6,0	11,1	981	1620	154,90	1200	1600	23134CW33J	23134CKW33J
		280	109,0	2,1	4,5	8,3	1150	2090	199,84	670	850	24134CW33J	24134CK30W33J
		310	86,0	4,0	7,5	13,9	921	1310	122,86	1100	1400	22234W33M	22234KW33M
		310	86,0	4,0	7,5	13,9	1080	1600	150,05	1300	1700	22234CW33J	22234CKW33J
		310	110,0	4,0	7,5	13,9	1340	2040	191,32	950	1300	23234CW33J	23234CKW33J
310	110,0	4,0	7,5	13,9	1280	1880	176,31	950	1300	23234CW33M	23234CKW33M		
180	360	120,0	4,0	9,0	16,7	1400	1970	179,34	940	1200	22334W33M*	22334KW33M	
	360	120,0	4,0	9,0	16,7	1670	2280	207,56	900	1200	22334CW33J	22334CKW33J	
	180	250	52,0	2,0	3,0	5,5	496	919	89,08	1700	2200	23936CW33J	23936CKW33J
		250	52,0	2,0	3,0	5,5	515	919	89,08	1700	2200	23936EW33MH**	23936EKW33MH
		280	74,0	2,1	7,5	13,9	837	1410	133,93	1400	1800	23036CW33J	23036CKW33J
		280	74,0	2,1	6,0	11,1	725	1230	116,83	1000	1300	23036W33M	23036KW33M
		280	100,0	2,1	4,5	8,3	1050	1980	188,08	950	1300	24036CW33J	24036CK30W33J
		280	100,0	2,1	4,5	8,3	1170	1980	188,08	950	1300	24036EW33MH**	24036EK30W33MH
		300	96,0	3,0	6,0	11,1	957	1540	144,43	940	1200	23136W33M	23136KW33M
		300	96,0	3,0	7,5	13,9	1150	1890	177,25	1100	1500	23136CW33J	23136CKW33J
		300	118,0	3,0	6,0	11,1	1220	2080	195,07	630	800	24136CW33J	24136CK30W33J
		320	86,0	4,0	9,0	16,7	1120	1700	157,49	1300	1700	22236CW33J	22236CKW33J
		320	86,0	4,0	9,0	16,7	943	1380	127,84	1000	1300	22236W33M	22236KW33M
		320	112,0	4,0	7,5	13,9	1360	2110	195,47	900	1200	23236CW33M	23236CKW33M
		320	112,0	4,0	7,5	13,9	1400	2210	204,74	900	1200	23236CW33J	23236CKW33J
		380	126,0	4,0	12,0	22,3	1540	2130	190,73	890	1100	22336W33M*	22336KW33M
380		126,0	4,0	12,0	22,3	1840	2530	226,55	900	1200	22336CW33J	22336CKW33J	
190	260	52,0	2,0	3,0	5,5	551	966	92,37	1700	2200	23938EW33MH**	23938EKW33MH	
	290	75,0	2,1	7,5	13,9	873	1510	141,61	1300	1700	23038CW33J	23038CKW33J	
	290	75,0	2,1	6,0	11,1	759	1310	122,86	940	1200	23038W33M	23038KW33M	
	290	100,0	2,1	4,5	8,3	1080	2070	194,13	920	1250	24038CW33J	24038CK30W33J	
	320	104,0	3,0	7,5	13,9	1130	1840	169,45	890	1100	23138W33M	23138KW33M	
	320	104,0	3,0	7,5	13,9	1310	2180	200,76	1000	1400	23138CW33J	23138CKW33J	
	340	92,0	4,0	9,0	16,7	1270	1900	172,97	1200	1600	22238CW33J	22238CKW33J	
	340	92,0	4,0	9,0	16,7	1040	1550	141,11	940	1200	22238W33M	22238KW33M	
	340	120,0	4,0	9,0	16,7	1550	2420	220,31	850	1100	23238CW33M	23238CKW33M	
	340	120,0	4,0	9,0	16,7	1580	2530	230,32	850	1100	23238CW33J	23238CKW33J	
	400	132,0	5,0	12,0	22,3	1920	2710	238,90	840	1000	22338CW33M	22338CKW33M	
	400	132,0	5,0	12,0	22,3	2030	2810	247,71	850	1100	22338CW33J	22338CKW33J	
	200	280	60,0	2,1	4,5	8,3	692	1160	108,79	1600	2000	23940EW33MH**	23940EKW33MH
		310	82,0	2,1	7,5	13,9	1010	1730	159,32	1200	1600	23040CW33J	23040CKW33J
310		82,0	2,1	6,0	11,1	880	1550	142,74	890	1100	23040W33M	23040KW33M	
310		109,0	2,1	6,0	11,1	1250	2370	218,26	900	1200	24040CW33J	24040CK30W33J	
310		109,0	2,1	6,0	11,1	1390	2370	218,26	900	1200	24040EW33MH**	24040EK30W33MH	
340		112,0	3,0	9,0	16,7	1240	2010	181,96	840	1000	23140W33M*	23140KW33M	

Deliveries of bearings marked with \* must be agreed with the producer.

\*\* Bearings in the new standard NEW FORCE (see the catalogue NEW FORCE)

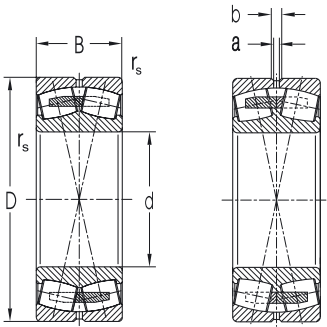

EMH

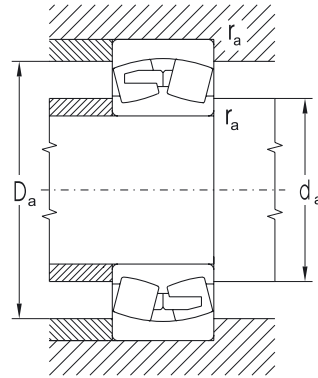

Abutment and Fillet Dimensions				Weight		Corresp. Adapter Sleeve	Corresp. Withdrawal Sleeve	Corresp. Nut	Factors				
d	d <sub>a</sub> min	D <sub>a</sub> max	r <sub>a</sub> max	K					e	Y <sub>1</sub>	Y <sub>2</sub>	Y <sub>0</sub>	
mm				kg									
160	178	322	3.0	51,90	50,800	H2332	AH2332	KM36	0,37	1,8	2,6	1,7	
170	182	248	2.0	12,60	12,200	H3034	AH3034	KM36	0,23	2,9	4,4	2,9	
	182	248	2.0	13,80	13,400	H3034	AH3034	KM36	0,25	2,7	3,9	2,6	
	182	248	2.0	17,30	17,100	–	AH24034	KM36	0,31	2,2	3,2	2,1	
	182	268	2.0	22,80	22,200	H3134	AH3134	KM38	0,31	2,1	3,1	2,0	
	182	268	2.0	21,00	20,400	H3134	AH3134	KM38	0,29	2,4	3,5	2,3	
	182	268	2.0	27,00	26,600	–	AH24134	KM36	0,36	1,9	2,8	1,8	
	188	292	3.0	30,00	29,400	H3134	AH3134	KM38	0,29	2,3	3,3	2,1	
	188	292	3.0	27,60	27,000	H3134	AH3134	KM38	0,26	2,6	3,9	2,6	
	188	292	3.0	35,30	34,300	H2334	AH3234	KM38	0,34	2,0	3,0	2,0	
	188	292	3.0	37,70	36,400	H2334	AH3234	KM38	0,36	1,9	2,8	1,8	
	188	342	3.0	59,20	58,200	H2334	AH2334	KM38	0,37	1,8	2,6	1,7	
	188	342	3.0	56,80	55,500	H2334	AH2334	KM38	0,33	2,1	3,1	2,0	
180	190	240	2.0	7,74	7,500	H3936	–	–	0,18	3,7	5,5	3,7	
	190	240	2.0	7,67	7,430	H3936	–	–	0,18	3,7	5,5	3,7	
	192	268	2.0	16,30	15,800	H3036	AH3036	KM38	0,24	2,9	4,2	2,8	
	192	268	2.0	17,60	17,100	H3036	AH3036	KM38	0,26	2,6	3,7	2,5	
	192	268	2.0	22,90	22,600	–	AH24036	KM38	0,32	2,1	3,1	2,0	
	192	268	2.0	23,20	22,900	–	AH24036	KM38	0,32	2,1	3,1	2,0	
	194	286	2.5	28,90	28,000	H3136	AH3136	KM40	0,32	2,1	3,0	2,0	
	194	286	2.5	26,60	25,800	H3136	AH3136	KM40	0,29	2,3	3,4	2,3	
	194	286	2.5	32,90	32,400	–	AH24136	KM38	0,37	1,8	2,7	1,8	
	198	302	3.0	29,10	28,400	H3136	AH2236	KM40	0,25	2,7	4,0	2,7	
	198	302	3.0	31,50	30,800	H3136	AH2236	KM40	0,28	2,4	3,4	2,3	
	198	302	3.0	39,80	38,600	H2336	AH3236	KM40	0,36	1,9	2,8	1,9	
	198	302	3.0	37,50	36,300	H2336	AH3236	KM40	0,33	2,1	3,1	2,0	
	198	362	3.0	73,20	71,700	H2336	AH2336	KM40	0,37	1,8	2,6	1,7	
	198	362	3.0	65,80	64,300	H2336	AH2336	KM40	0,33	2,1	3,1	2,0	
	190	200	250	2.0	8,05	7,790	H3938	–	–	0,17	3,9	5,8	3,8
		202	278	2.0	17,40	16,900	H3038	AH3038	HML41T	0,23	2,9	4,4	2,9
		202	278	2.0	18,80	18,300	H3038	AH3038	HML41T	0,25	2,7	3,8	2,5
202		278	2.0	23,70	23,300	–	AH24038	KM40	0,31	2,2	3,2	2,1	
204		306	2.5	36,10	35,000	H3138	AH3138	HM42T	0,32	2,1	3,0	2,0	
204		306	2.5	33,60	32,600	H3138	AH3138	HM42T	0,30	2,3	3,4	2,2	
208		322	3.0	35,10	34,300	H3138	AH2238	HM42T	0,25	2,7	4,0	2,6	
208		322	3.0	38,40	37,700	H3138	AH2238	HM42T	0,29	2,3	3,4	2,2	
208		322	3.0	47,70	47,100	H2338	AH3238	HM42T	0,36	1,9	2,8	1,9	
208		322	3.0	45,80	44,400	H2338	AH3238	HM42T	0,33	2,0	3,0	2,0	
212		378	4.0	84,10	82,900	H2338	AH2338	HM42T	0,36	1,9	2,8	1,9	
212		378	4.0	76,30	74,600	H2338	AH2338	HM42T	0,32	2,1	3,1	2,0	
200		212	268	2.0	11,30	11,000	H3940	–	–	0,19	3,6	5,4	3,5
		212	298	2.0	22,20	21,500	H3040	AH3040	HML43T	0,24	2,9	4,3	2,8
	212	298	2.0	23,80	23,400	H3040	AH3040	HML43T	0,25	2,7	4,0	2,7	
	212	298	2.0	30,10	29,600	–	AH24040	HM42T	0,32	2,1	3,1	2,1	
	212	298	2.0	30,80	30,300	–	AH24040	HM42T	0,32	2,1	3,1	2,1	
	214	326	2.5	44,00	42,700	H3140	AH3140	HM44T	0,33	2,0	2,9	1,9	



# Double Row Spherical Roller Bearings

d = 200 to 260 mm

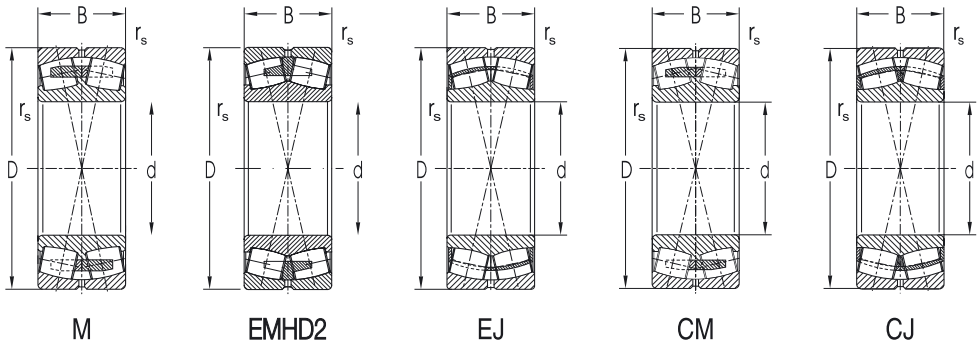

Dimensions						Basic Load Rating		Fatigue load limit	Limiting Speed for Lubrication with		Bearing Designation		
d	D	B	r <sub>s</sub>	a	b	Dyn. C <sub>r</sub>	Stat. C <sub>or</sub>	P <sub>u</sub>	Grease	Oil	with Cylindrical Bore	with Tapered Bore	
mm						kN		kN	min <sup>-1</sup>				
200	340	112,0	3,0	9,0	16,7	1480	2410	218,17	950	1300	23140CW33J	23140CKW33J	
	340	112,0	3,0	9,0	16,7	1630	2410	218,17	950	1300	23140EW33MH**	23140EKW33MH	
	340	140,0	3,0	6,0	11,1	1920	3160	286,06	560	700	24140EW33MH**	24140EK30W33MH	
	360	98,0	4,0	9,0	16,7	1420	2140	191,63	1100	1500	22240CW33J	22240CKW33J	
	360	98,0	4,0	9,0	16,7	1160	1760	157,60	890	1100	22240W33M	22240KW33M	
	360	128,0	4,0	9,0	16,7	1710	2760	247,14	800	1000	23240CW33M	23240CKW33M	
	360	128,0	4,0	9,0	16,7	1760	2850	255,20	800	1000	23240CW33J	23240CKW33J	
	420	138,0	5,0	12,0	22,3	1820	2650	230,16	790	940	22340W33M	22340KW33M	
420	138,0	5,0	12,0	22,3	2230	3110	270,11	800	1000	22340CW33J	22340CKW33J		
220	300	60,0	2,1	4,5	8,3	730	1330	109,87	1500	1900	23944EW33MH**	23944EKW33MH	
	340	90,0	3,0	7,5	13,9	1200	2090	187,15	1100	1500	23044CW33J	23044CKW33J	
	340	90,0	3,0	7,5	13,9	1020	1850	165,66	790	940	23044CW33M	23044CKW33M	
	340	90,0	3,0	7,5	13,9	1320	2090	187,15	1100	1500	23044EW33MH**	23044EKW33MH	
	340	118,0	3,0	6,0	11,1	1650	2830	253,41	850	1100	24044EW33MH**	24044EK30W33MH	
	340	118,0	3,0	6,0	11,1	1480	2830	253,41	850	1100	24044CW33J	24044CK30W33J	
	370	120,0	4,0	9,0	16,7	1480	2470	217,74	750	890	23144W33M*	23144KW33M	
	370	120,0	4,0	9,0	16,7	1710	2890	254,76	900	1200	23144CW33J	23144CKW33J	
	370	120,0	4,0	9,0	16,7	1880	2890	254,76	900	1200	23144EW33MH**	23144EKW33MH	
	370	150,0	4,0	6,0	11,1	2200	3690	325,29	500	630	24144EW33MH**	24144EK30W33MH	
	400	108,0	4,0	9,0	16,7	1730	2630	228,42	950	1300	22244CW33J	22244CKW33J	
	400	108,0	4,0	9,0	16,7	1380	2080	180,65	790	940	22244W33M	22244KW33M	
	400	144,0	4,0	9,0	16,7	2040	3290	285,74	710	840	23244CW33M	23244CKW33M	
	400	144,0	4,0	9,0	16,7	2190	3610	313,53	750	950	23244CW33J	23244CKW33J	
	460	145,0	5,0	9,0	16,7	2110	3130	264,42	750	890	22344W33M	22344KW33M	
	240	320	60,0	2,1	4,5	8,3	750	1450	115,51	1300	1700	23948EW33MH**	23948EKW33MH
360		92,0	3,0	7,5	13,9	1080	2010	176,30	750	890	23048CW33M	23048CKW33M	
360		92,0	3,0	7,5	13,9	1260	2310	202,61	1000	1400	23048CW33J	23048CKW33J	
360		92,0	3,0	7,5	13,9	1390	2310	202,61	1000	1400	23048EW33MH**	23048EKW33MH	
360		118,0	3,0	6,0	11,1	1690	3060	268,39	800	1000	24048EW33MH**	24048EK30W33MH	
400		128,0	4,0	9,0	16,7	1690	2860	246,04	710	840	23148W33M*	23148KW33M	
400		128,0	4,0	9,0	16,7	1960	3340	287,33	850	1100	23148CW33J	23148CKW33J	
400		128,0	4,0	9,0	16,7	2160	3340	287,33	850	1100	23148EW33MH**	23148EKW33MH	
400		160,0	4,0	6,0	11,1	2510	4260	366,48	480	600	24148EW33MH**	24148EK30W33MH	
440		120,0	4,0	12,0	22,3	2050	3070	259,35	900	1200	22248CW33J	22248CKW33J	
440		120,0	4,0	12,0	22,3	1660	2560	216,26	750	890	22248W33M	22248KW33M	
440		160,0	4,0	12,0	22,3	2440	3920	331,15	670	850	23248CW33M	23248CKW33M	
500		155,0	5,0	12,0	22,3	2440	3690	303,91	670	790	22348W33M	22348KW33M	
260		360	75,0	2,1	4,5	8,3	1070	1930	167,62	1100	1500	23952EW33MH**	23952EKW33MH
		400	104,0	4,0	9,0	16,7	1580	2790	237,81	900	1200	23052CW33J	23052CKW33J
		400	104,0	4,0	9,0	16,7	1460	2360	201,16	670	790	23052CW33M	23052CKW33M
	400	140,0	4,0	6,0	11,1	2190	4020	342,66	700	900	24052EW33MH**	24052EK30W33MH	
	440	144,0	4,0	9,0	16,7	2240	3720	311,54	670	790	23152CW33M*	23152CKW33M	
	440	144,0	4,0	9,0	16,7	2370	4130	345,87	670	790	23152CW33J	23152CKW33J	
	440	144,0	4,0	9,0	16,7	2610	4130	345,87	800	1000	23152EW33MH**	23152EKW33MH	
	440	180,0	4,0	7,5	13,9	3100	5320	445,53	430	530	24152EW33MH**	24152EK30W33MH	
	480	130,0	5,0	12,0	22,3	1940	3030	249,56	670	790	22252W33M	22252KW33M	

Deliveries of bearings marked with \* must be agreed with the producer.

\*\* Bearings in the new standard NEW FORCE (see the catalogue NEW FORCE)



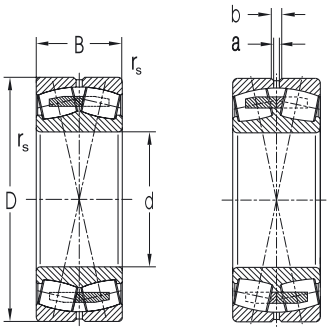

EMH

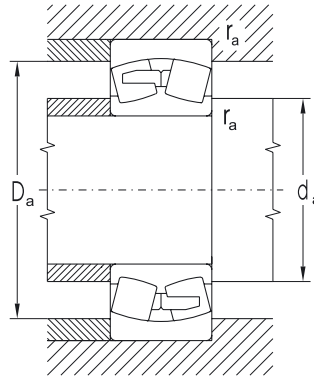

Abutment and Fillet Dimensions				Weight		Corresp. Adapter Sleeve	Corresp. Withdrawal Sleeve	Corresp. Nut	Factors				
d	d <sub>a</sub> min	D <sub>a</sub> max	r <sub>a</sub> max	K					e	Y <sub>1</sub>	Y <sub>2</sub>	Y <sub>0</sub>	
mm				kg									
200	214	326	2,5	40,50	39,200	H3140	AH3140	HM44T	0,30	2,2	3,3	2,2	
	214	326	2,5	41,50	40,200	H3140	AH3140	HM44T	0,30	2,2	3,3	2,2	
	214	326	2,5	53,40	52,600	–	AH24140	HM42T	0,39	1,9	2,6	1,7	
	218	342	3,0	43,00	42,000	H3140	AH2240	HM44T	0,25	2,6	3,9	2,6	
	218	342	3,0	46,00	45,100	H3140	AH2240	HM44T	0,29	2,3	3,3	2,2	
	218	342	3,0	58,60	56,700	H2340	AH3240	HM44T	0,36	1,9	2,8	1,8	
	218	342	3,0	55,10	53,500	H2340	AH3240	HM44T	0,33	2,0	3,0	2,0	
	222	398	4,0	99,00	97,000	H2340	AH2340	HM44T	0,36	1,9	2,7	1,8	
	222	398	4,0	89,20	87,200	H2340	AH2340	HM44T	0,32	2,1	3,1	2,0	
	220	232	288	2,0	12,30	12,000	H3944	–	–	0,16	4,2	6,3	4,0
234		326	2,5	29,20	28,300	H3044	AH3044	HML47T	0,24	2,9	4,3	2,8	
234		326	2,5	32,10	31,200	H3044	AH3044	HML47T	0,25	2,7	4,0	2,7	
234		326	2,5	29,60	28,700	H3044	AH3044	HML47T	0,24	2,9	4,3	2,8	
234		326	2,5	39,70	39,000	–	AOH24044	HM46T	0,32	2,3	3,1	2,1	
234		326	2,5	39,00	38,300	–	AOH24044	HM46T	0,32	2,3	3,1	2,1	
238		352	3,0	56,80	55,200	H3144	AH3144	HM48T	0,32	2,0	3,0	2,0	
238		352	3,0	50,80	49,200	H3144	AH3144	HM48T	0,30	2,3	3,4	2,2	
238		352	3,0	52,30	50,700	H3144	AH3144	HM48T	0,30	2,3	3,4	2,2	
238		352	3,0	67,10	66,100	–	AOH24144	HM46T	0,38	1,8	2,6	1,7	
238		382	3,0	58,80	57,500	H3144	AH2244	HM48T	0,25	2,7	4,0	2,6	
238		382	3,0	63,00	61,000	H3144	AH2244	HM48T	0,28	2,4	3,4	2,2	
238		382	3,0	83,00	79,000	H2344	AH2344	HM48T	0,36	1,9	2,8	1,8	
238		382	3,0	77,90	75,500	H2344	AH2344	HM48T	0,34	2,0	3,0	2,0	
242		438	4,0	125,00	122,000	H2344	AH2344	HM48T	0,35	1,9	2,8	1,8	
240		252	308	2,0	13,30	13,000	H3948	–	–	0,15	4,5	6,7	4,5
		254	346	2,5	34,90	33,800	H3048	AH3048	HML52T	0,24	2,8	4,2	2,8
		254	346	2,5	32,40	31,000	H3048	AH3048	HML52T	0,23	3,0	4,5	2,9
	254	346	2,5	32,40	31,400	H3048	AH3048	HML52T	0,23	3,0	4,5	2,9	
	254	346	2,5	42,80	42,100	–	AOH24048	HM50T	0,30	2,3	3,4	2,2	
	258	382	3,0	68,70	66,700	H3148	AH3148	HM52T	0,32	2,1	3,0	2,0	
	258	382	3,0	63,00	61,000	H3148	AH3148	HM52T	0,29	2,3	3,4	2,3	
	258	382	3,0	64,50	62,500	H3148	AH3148	HM52T	0,29	2,3	3,4	2,3	
	258	382	3,0	82,50	81,300	–	AOH24148	HM50T	0,38	1,8	2,7	1,8	
	258	422	3,0	80,00	78,200	H3148	AH2248	HM52T	0,26	2,6	3,9	2,6	
	258	422	3,0	85,00	83,200	H3148	AH2248	HM52T	0,29	2,3	3,3	2,2	
	258	422	3,0	111,00	108,000	H2348	AH2348	HM52T	0,35	1,9	2,9	1,8	
	262	478	4,0	159,00	156,000	H2348	AH2348	HM52T	0,34	2,0	2,9	1,9	
	260	272	348	2,0	22,90	22,200	H3952	–	–	0,18	3,7	5,5	3,7
278		382	3,0	45,80	44,400	H3052	AH3052	HM56T	0,23	2,9	4,3	2,9	
278		382	3,0	46,80	45,300	H3052	AH3052	HML56T	0,25	2,7	4,0	2,7	
278		385	3,0	65,00	63,900	–	AOH24052	HM54T	0,32	2,1	3,1	2,1	
278		422	3,0	90,50	87,800	H3152	AH3152	HM58T	0,32	2,0	3,1	2,0	
278		422	3,0	87,80	85,000	H3152	AH3152	HM58T	0,32	2,0	3,1	2,0	
278		422	3,0	90,30	87,500	H3152	AH3152	HM58T	0,30	2,2	3,3	2,2	
278		422	3,0	115,00	113,000	–	AOH24152	HM56T	0,39	1,8	2,6	1,7	
282		458	4,0	111,00	109,000	H3152	AH2252	HM58T	0,29	2,3	3,4	2,2	



# Double Row Spherical Roller Bearings

d = 260 to 380 mm

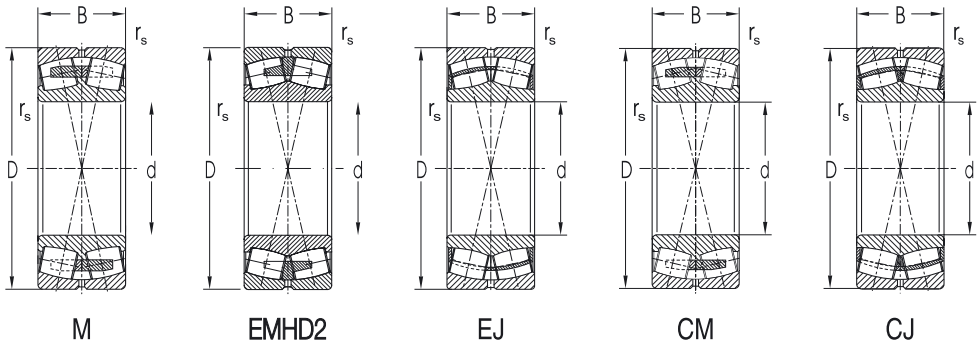

Dimensions				Basic Load Rating		Fatigue load limit	Limiting Speed for Lubrication with		Bearing Designation			
d	D	B	r <sub>s</sub>	a	b	P <sub>u</sub>	Grease	Oil	with Cylindrical Bore	with Tapered Bore		
mm				min		kN	min <sup>-1</sup>					
260	480	174,0	5,0	12,0	22,3	2700	4430	364,86	600	710	23252W33M	23252KW33M
	540	165,0	6,0	12,0	22,3	2760	4220	339,53	600	710	22352W33M	22352KW33M
280	380	75,0	2,1	4,5	8,3	1120	2100	179,00	1000	1400	23956EW33MH**	23956EKW33MH
	420	106,0	4,0	9,0	16,7	1440	2690	225,28	630	750	23056W33M*	23056KW33M
	420	106,0	4,0	9,0	16,7	1820	3060	256,26	850	1100	23056EW33MH**	23056EKW33MH
	420	106,0	4,0	9,0	16,7	1650	3060	256,26	850	1100	23056CW33J	23056CKW33J
	420	140,0	4,0	6,0	11,1	2240	4280	358,43	670	850	24056EW33MH**	24056EK30W33MH
	460	146,0	5,0	9,0	16,7	2180	3900	321,21	600	710	23156W33M*	23156KW33M
	460	146,0	5,0	9,0	16,7	2650	4370	359,92	750	950	23156EW33MH**	23156EKW33MH
	460	146,0	5,0	9,0	16,7	2500	4470	368,16	750	950	23156CW33J	23156CKW33J
	460	180,0	5,0	7,5	13,9	3220	5630	463,70	400	500	24156EW33MH**	24156EK30W33MH
	500	130,0	5,0	12,0	22,3	2010	3200	259,43	630	750	22256W33M	22256KW33M
	500	176,0	5,0	12,0	22,3	2850	4770	386,71	560	670	23256W33M	23256KW33M
	580	175,0	6,0	12,0	22,3	3300	4940	388,93	600	750	22356CW33M	22356CKW33M
300	420	90,0	3,0	6,0	11,1	1500	2690	221,55	950	1300	23960EW33MH**	23960EKW33MH
	460	118,0	4,0	9,0	16,7	1780	3240	264,73	560	670	23060W33M*	23060KW33M
	460	118,0	4,0	9,0	16,7	2220	3720	303,94	800	1000	23060EW33MH**	23060EKW33MH
	460	118,0	4,0	9,0	16,7	2020	3720	303,94	800	1000	23060CW33J	23060CKW33J
	460	160,0	4,0	7,5	13,9	2800	5230	427,32	600	750	24060EW33MH**	24060EK30W33MH
	500	160,0	5,0	9,0	16,7	2560	4490	361,26	530	630	23160W33M*	23160KW33M
	500	200,0	5,0	7,5	13,9	3830	6790	546,31	360	450	24160EW33MH**	24160EK30W33MH
	540	140,0	5,0	12,0	22,3	2350	3810	302,09	560	670	22260W33M	22260KW33M
	540	192,0	5,0	12,0	22,3	3350	5570	441,64	500	600	23260W33M	23260KW33M
	320	440	90,0	3,0	6,0	11,1	1450	2830	231,23	900	1200	23964EW33MH**
480		121,0	4,0	9,0	16,7	1890	3510	282,41	530	630	23064W33M*	23064KW33M
480		121,0	4,0	9,0	16,7	2110	4090	329,07	750	950	23064CW33J	23064CKW33J
480		160,0	4,0	7,5	13,9	2885	5500	442,52	560	700	24064EW33MH**	24064EK30W33MH
540		176,0	5,0	12,0	22,3	3020	5390	424,36	500	600	23164W33M*	23164KW33M
540		176,0	5,0	12,0	22,3	3780	6150	484,20	630	800	23164EW33MH**	23164EKW33MH
540		176,0	5,0	12,0	22,3	3430	6150	484,20	630	800	23164CW33J	23164CKW33J
540		218,0	5,0	9,0	16,7	4470	7870	619,61	340	430	24164EW33MH**	24164EK30W33MH
580		150,0	5,0	12,0	22,3	2700	4430	344,05	530	630	22264W33M	22264KW33M
580		208,0	5,0	12,0	22,3	3880	6520	506,37	450	530	23264W33M	23264KW33M
340	520	133,0	5,0	12,0	22,3	2320	4330	340,91	500	600	23068W33M*	23068KW33M
	520	180,0	5,0	9,0	16,7	3550	6710	528,28	530	670	24068EW33MH**	24068EK30W33MH
	580	190,0	5,0	12,0	22,3	3510	6230	480,67	450	530	23168W33M*	23168KW33M
	580	190,0	5,0	12,0	22,3	4240	7080	536,22	600	750	23168EW33MH**	23168EKW33MH
	580	190,0	5,0	12,0	22,3	4020	7080	546,25	600	750	23168CW33J	23168CKW33J
	620	224,0	6,0	12,0	22,3	4430	7560	575,88	420	500	23268W33M	23268KW33M
	620	224,0	6,0	12,0	22,3	4430	7560	575,88	420	500	23268W33M	23268KW33M
360	540	134,0	5,0	12,0	22,3	2360	4460	346,38	450	530	23072W33M*	23072KW33M
	600	192,0	5,0	12,0	22,3	3630	6550	498,95	420	500	23172W33M*	23172KW33M
	600	243,0	5,0	9,0	16,7	5360	9970	759,47	300	380	24172EW33MH**	24172EK30W33MH
	650	232,0	6,0	12,0	22,3	4780	8550	641,45	400	500	23272CW33M	23272CKW33M
380	560	135,0	5,0	12,0	22,3	2410	4700	360,29	420	500	23076W33M*	23076KW33M
	560	180,0	5,0	9,0	16,7	3690	7420	568,80	480	600	24076EW33MH**	24076EK30W33MH
	620	194,0	5,0	12,0	22,3	3740	6970	524,48	400	470	23176W33M*	23176KW33M

Deliveries of bearings marked with \* must be agreed with the producer.

\*\* Bearings in the new standard NEW FORCE (see the catalogue NEW FORCE)

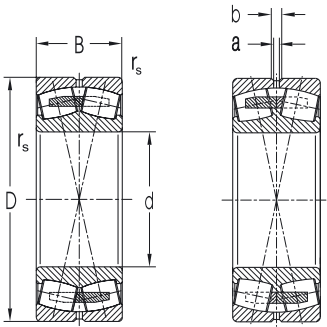

EMH

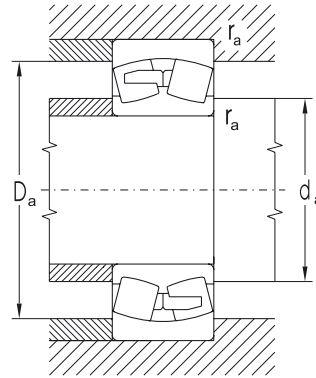

Abutment and Fillet Dimensions				Weight		Corresp. Adapter Sleeve	Corresp. Withdrawal Sleeve	Corresp. Nut	Factors				
d	d <sub>a</sub> min	D <sub>a</sub> max	r <sub>a</sub> max	K					e	Y <sub>1</sub>	Y <sub>2</sub>	Y <sub>0</sub>	
mm				kg									
260	282	458	4.0	147,00	142,000	H2352	AH2352	HM58T	0,37	1,8	2,6	1,7	
	288	512	5.0	196,00	192,000	H2352	AH2352	HM58T	0,34	2,0	2,9	1,9	
280	292	368	2.0	25,00	24,200	H3956	-	-	0,16	4,2	6,3	4,0	
	298	402	3.0	54,50	52,900	H3056	AH3056	HM3060	0,24	2,7	4,0	2,6	
	298	402	3.0	51,50	49,900	H3056	AH3056	HM3060	0,22	3,0	4,5	3,0	
	298	402	3.0	50,00	48,400	H3056	AH3056	HM3060	0,22	3,0	4,5	3,0	
	298	402	3.0	69,70	68,600	-	AOH 24056	HM52T	0,30	2,2	3,3	2,2	
	302	438	4.0	103,00	99,000	H3156	AH3156	HM62T	0,31	2,1	3,0	2,0	
	322	438	4.0	95,00	91,000	H3156	AH3156	HM62T	0,29	2,3	3,3	2,2	
	302	438	4.0	93,90	90,800	H3156	AH3156	HM62T	0,29	2,3	3,5	2,3	
	302	438	4.0	121,00	119,000	-	AOH24156	HM3160	0,37	1,8	2,7	1,8	
	302	478	4.0	119,00	116,000	H3156	AH2256	HM62T	0,28	2,4	3,5	2,3	
	302	478	4.0	157,00	152,000	H2356	AH2356	HM62T	0,36	1,9	2,7	1,8	
	308	552	5.0	232,00	227,000	H2356	AH2356	HM62T	0,31	2,2	3,2	2,1	
	300	314	406	2.5	38,3	37,000	H3960	-	-	0,19	3,6	5,4	3,5
		318	442	3.0	75,80	73,600	H3060	AH3060	HM3064	0,25	2,7	3,8	2,5
318		442	3.0	71,50	69,400	H3060	AH3060	HM3064	0,23	3,0	4,4	2,9	
318		442	3.0	69,6	67,500	H3060	AH3060	HM3064	0,23	3,0	4,4	2,9	
318		442	3.0	97,70	96,200	-	AOH24060	HM62T	0,32	2,1	3,2	2,1	
322		478	4.0	134,00	130,000	H3160	AH3160	HM66T	0,32	2,1	3,0	2,0	
322		478	4.0	163,00	160,000	-	AOH24160	HM3164	0,37	1,8	2,7	1,8	
322		518	4.0	150,00	147,000	H3160	AH2260	HM66T	0,27	2,5	3,6	2,4	
322		518	4.0	200,00	195,000	H3260	AH3260	HM66T	0,36	1,8	2,7	1,8	
320		334	426	2.5	40,40	39,100	H3964	-	-	0,18	3,8	5,7	3,7
	338	462	3.0	81,20	78,800	H3064	AH3064	HML69T	0,24	2,7	3,9	2,6	
	338	462	3.0	76,10	73,700	H3064	AH3064	HML69T	0,22	3,0	4,5	3,0	
	338	462	3.0	103,00	101,500	-	AOH24064	HM66T	0,30	2,2	3,3	2,2	
	342	518	4.0	175,00	170,000	H3164	AH3164	HM70T	0,32	2,0	3,0	2,0	
	342	518	4.0	162,00	157,000	H3164	AH3164	HM70T	0,30	2,2	3,3	2,2	
	342	518	4.0	160,00	155,000	H3164	AH3164	HM70T	0,30	2,2	3,3	2,2	
	342	518	4.0	208,00	205,000	-	AOH24164	HM3168	0,38	1,8	2,6	1,7	
	342	558	4.0	187,00	181,000	H3164	AH2264	HM70T	0,27	2,5	3,6	2,3	
	342	558	4.0	253,00	246,000	H3264	AH3264	HM70T	0,37	1,8	2,6	1,7	
340	362	498	4.0	108,00	105,000	H3068	AH3068	HML73T	0,25	2,7	3,9	2,6	
	362	498	4.0	141,00	139,000	-	AOH24068	HM3072	0,33	2,0	3,0	2,0	
	362	558	4.0	209,00	202,000	H3168	AH3168	HM74T	0,33	2,0	2,9	1,9	
	362	558	4.0	206,00	199,000	H3168	AH3168	HM74T	0,30	2,2	3,3	2,2	
	362	558	4.0	201,00	195,000	H3168	AH3168	HM74T	0,30	2,2	3,3	2,2	
	368	592	5.0	313,00	304,000	H3268	AH3268	HM74T	0,37	1,8	2,6	1,7	
360	382	518	4.0	114,00	111,000	H3072	AH3072	HML77T	0,24	2,8	4,0	2,6	
	382	578	4.0	232,00	224,000	H3172	AH3172	HM80T	0,32	2,0	3,0	2,0	
	382	578	4.0	284,00	279,000	-	AOH24172	HM3176	0,38	1,8	2,6	1,7	
	388	622	5.0	342,00	332,000	H3272	AH3272G	HM3076	0,35	1,9	2,9	1,8	
380	402	538	4.0	120,00	117,000	H3076	AH3076	HML82T	0,23	2,9	4,2	2,7	
	402	538	4.0	154,00	152,000	-	AOH24076	HM3080	0,29	2,3	3,5	2,3	
	402	598	4.0	244,00	237,000	H3176	AH3176	HM84T	0,31	2,2	3,1	2,1	



# Double Row Spherical Roller Bearings

d = 380 to 950 mm

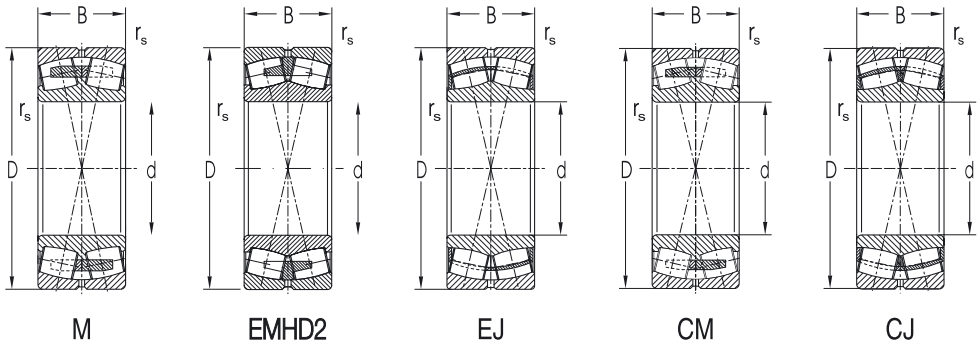

Dimensions						Basic Load Rating		Fatigue load limit	Limiting Speed for Lubrication with		Bearing Designation	
d	D	B	r <sub>s</sub>	a	b	Dyn. C <sub>r</sub>	Stat. C <sub>or</sub>	P <sub>u</sub>	Grease	Oil	with Cylindrical Bore	with Tapered Bore
mm						kN		kN	min <sup>-1</sup>			
380	620	243,0	5,0	9,0	16,7	5500	10490	789,35	280	360	24176EW33MH**	24176EK30W33MH
	680	240,0	6,0	12,0	22,3	5160	8920	659,58	380	480	23276W33M	23276KW33M
400	600	148,0	5,0	12,0	22,3	2860	5500	413,86	400	470	23080W33M	23080KW33M
	650	200,0	6,0	12,0	22,3	4040	7580	562,09	380	450	23180W33M	23180KW33M
	650	250,0	6,0	12,0	22,3	5960	11150	826,82	180	240	24180EW33MH**	24180EK30W33MH
	720	256,0	6,0	12,0	22,3	5800	10120	736,05	350	420	23280W33M	23280KW33M
420	820	243,0	7,5	12,0	22,3	6350	10190	722,37	360	450	22380CW33M	22380CKW33M
	620	150,0	5,0	12,0	22,3	2950	5850	435,05	380	450	23084W33M	23084KW33M
	700	224,0	6,0	12,0	22,3	5030	9740	708,42	360	450	23184CW33M	23184CKW33M
	700	280,0	6,0	12,0	22,3	6440	13480	980,44	170	220	24184EW33MH	24184EK30W33MH
440	760	272,0	7,5	12,0	22,3	6400	11300	809,11	320	400	23284CW33M	23284CKW33M
	650	157,0	6,0	12,0	22,3	3210	6410	470,03	350	420	23088W33M	23088KW33M
440	720	226,0	6,0	12,0	22,3	4480	9350	672,93	330	400	23188W33M	23188KW33M
	790	280,0	7,5	12,0	22,3	6820	12030	850,73	320	380	23288W33M	23288KW33M
460	680	163,0	6,0	12,0	22,3	3480	7000	506,43	330	400	23092W33M	23092KW33M
	760	240,0	7,5	12,0	22,3	5720	10950	776,25	320	380	23192W33M	23192KW33M
	760	300,0	7,5	12,0	22,3	7370	15530	1100,93	160	200	24192EW33MH	24192EK30W33MH
480	700	165,0	6,0	12,0	22,3	3660	7490	536,31	320	380	23096W33M	23096KW33M
	790	248,0	7,5	12,0	22,3	6150	12000	840,50	300	380	23196W33M	23196KW33M
	720	167,0	6,0	12,0	22,3	3830	7970	565,00	300	350	230500W33M	230500KW33M
500	830	264,0	7,5	12,0	22,3	6800	13040	900,78	280	330	231500W33M	231500KW33M
	920	336,0	7,5	12,0	22,3	10380	18770	1271,37	240	320	232500EW33MH	232500EKW33MH
530	780	185,0	6,0	12,0	22,3	4470	9310	646,05	280	330	230530W33M	230530KW33M
560	820	195,0	6,0	12,0	22,3	5110	10690	730,31	320	400	230560CW33M	230560CKW33M
600	870	200,0	6,0	12,0	22,3	5500	11420	765,54	260	300	230600CW33M	230600CKW33M
630	920	212,0	7,5	12,0	22,3	6270	13360	881,46	240	300	230630W33M	230630KW33M
	1030	315,0	7,5	12,0	22,3	9700	19600	1266,83	180	250	231630W33M	231630KW33M
670	980	230,0	7,5	12,0	22,3	6820	14690	951,20	200	280	230670W33M	230670KW33M
750	1360	475,0	15,0	12,0	22,3	18990	36950	2222,41	150	190	232750CW33M	232750CKW33M
	1360	475,0	15,0	12,0	22,3	18990	36950	2222,41	150	190	232750CW33F	232750CKW33F
800	1150	258,0	7,5	12,0	22,3	8620	19650	1210,17	180	220	230800W33M	230800KW33M
850	1220	272,0	7,5	12,0	22,3	9610	22080	1335,68	160	200	230850W33M	230850KW33M
950	1250	224,0	7,5	12,0	22,3	7830	21190	1258,63	170	220	239950EW33MH	239950EKW33MH

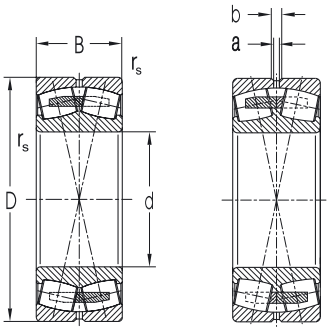

EMH

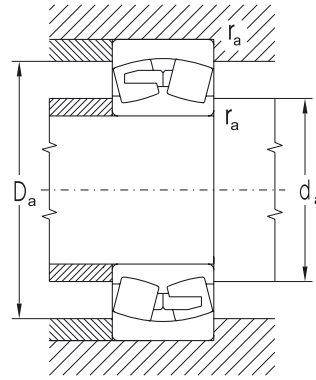

Abutment and Fillet Dimensions				Weight		Corresp. Adapter Sleeve	Corresp. Withdrawal Sleeve	Corresp. Nut	Factors			
d	d <sub>a</sub> min	D <sub>a</sub> max	r <sub>a</sub> max	K					e	Y <sub>1</sub>	Y <sub>2</sub>	Y <sub>0</sub>
mm				kg								
380	402	598	4,0	296,00	291,000	–	AOH24176	HM3180	0,36	1,9	2,8	1,8
	408	652	5,0	394,00	382,000	H3276	AH3276	HM84T	0,36	1,9	2,7	1,8
400	422	578	4,0	156,00	152,000	H3080	AH3080	HML86T	0,24	2,8	4,0	2,7
	428	622	5,0	273,00	265,000	H3180	AH3180	HM88T	0,30	2,2	3,2	2,1
	428	622	5,0	334,00	329,000	–	AH24180	HM3184	0,35	1,9	2,8	1,9
	428	692	5,0	476,00	463,000	H3280	AH3280	HM88T	0,36	1,8	2,7	1,8
	436	784	6,0	629,00	612,000	–	–	–	0,30	2,2	3,3	2,2
420	442	598	4,0	164,00	159,000	H3084	AH3084	HML90T	0,23	2,9	4,1	2,7
	448	672	5,0	363,00	348,000	H3184	AH3184	HM92T	0,32	2,1	3,2	2,0
	448	672	5,0	445,00	438,000	–	AOH24184	HM3188	0,37	1,8	2,7	1,8
	456	724	6,0	535,00	520,000	H3284	AH3284	HM92T	0,36	1,7	2,7	1,8
440	468	622	5,0	188,00	182,000	H3088	AH3088X	HML94T	0,23	2,9	4,1	2,7
440	468	692	5,0	390,00	379,000	H3188	AH3188X	HM96T	0,32	2,1	3,0	2,0
	476	754	6,0	613,00	595,000	H3288	AH3288X	HM96T	0,36	1,8	2,7	1,8
460	488	652	5,0	214,00	207,000	H3092	AH3092X	HML98T	0,23	2,9	4,2	2,8
	496	724	6,0	456,00	441,000	H3192	AH3192X	HM102T	0,31	2,1	3,1	2,0
	496	724	6,0	556,00	547,000	–	–	–	0,37	1,8	2,7	1,8
480	508	672	5,0	230,00	223,000	H3096	AH3096X	HML104T	0,23	2,9	4,4	2,9
	516	754	6,0	485,00	469,000	H3196	AH3196X	HM106T	0,31	2,2	3,1	2,1
500	528	692	5,0	236,00	228,000	H30/500	AH30/500X	HML108T	0,22	3,0	4,3	2,9
	536	794	6,0	570,00	550,000	H31/500	AH31/500X	HM110T	0,31	2,1	3,0	2,0
	536	884	6,0	976,00	946,000	H32/500	AH32/500X	HM110T	0,35	1,9	2,9	1,9
530	558	752	5,0	323,00	314,000	H30/530	AH30/530	HML112T	0,22	3,0	4,3	2,9
560	588	792	5,0	357,00	346,000	H30/560	AH30/560	HML118T	0,22	3,1	4,6	3,0
600	633	838	5,0	405,00	400,000	H30/600	AH30/600	HM30/630	0,22	2,9	4,2	2,8
630	666	884	6,0	485,00	470,000	H30/630	AH30/630	HM30/670	0,21	3,1	4,5	2,9
	666	994	6,0	1080,00	1070,000	H31/630	AH31/630	HM31/670	0,30	2,2	3,3	2,2
670	706	944	6,0	611,00	593,000	H30/670	AH30/670	HM30/710	0,23	3,0	4,4	2,9
750	815	1295	12,0	3070,00	2990,000	H32/750	AH32/750	HM31/800	0,34	2,0	2,9	1,9
	815	1295	12,0	3020,00	2930,000	H32/750	AH32/750	HM31/800	0,34	2,0	2,9	1,9
800	836	1114	6,0	939,00	911,000	H30/800	AH30/800	HM30/850	0,21	3,1	4,5	3,0
850	886	1184	6,0	1110,00	1080,000	–	AH30/850	HM30/900	0,21	3,1	4,5	3,0
950	986	1214	6,0	746,00	721,000	–	–	–	0,15	4,4	6,6	4,3



# Single Row Tapered Roller Bearings



## Single Row Tapered Roller Bearings

A design with a great number of tapered rollers in one row enables these bearings to reach high load ratings both in radial and axial directions. Axial load can be applied only in one direction and its size depends on the contact angle size. Bearings with a greater contact angle (type 313 and 323B) are suitable for greater axial forces.

Single row tapered roller bearing arrangement is usually created by a pair of bearings because of bidirectional accommodation of axial load.

Bearings are produced in design with higher utilization parameters - designation A. Besides bearings in metric dimensions bearings in inch dimensions are also produced.

## Boundary Dimensions

Boundary dimensions of metric single row tapered roller bearings comply with the standard ISO 355.

Boundary dimensions of single row tapered roller bearings in inch dimensions are according to the standard AFBMA Standard 19 (USA) from 1974.

## Designation

Bearing designation of standard bearings is in the dimension tables of this publication.

Difference from basic design is indicated by additional symbols shown in section 2.2 .

According to the dimensional plan ISO 355 the metric single row tapered roller bearing designation consists of letter and numerical symbols expressing following :

T	bearing type
2, 3, 4, 5, 7	angle series of bearing
B, C, D, E, F, G	diameter series of bearing
B, C, D, E	width series of bearing
000	bore diameter in mm

For customer's and producer's orientation previous the designation is retained in the dimension tables and designation according to ISO is also shown.

The bearings designation in inch dimensions corresponds to usual way of designation of most producers of these bearings. The number preceding the slash indicates the cone with tapered rollers and cage, the number after the slash indicates the cup.

## Cage

Single row tapered roller bearings have pressed steel cage which is not designated. Additional symbol J2 indicates a new cage design.

## Tolerance

Bearings are commonly produced in normal tolerance class P0 which is not indicated. For arrangements demanding more accuracy or working with high rotational speed, bearings in higher tolerance class P6, P6X and P5 are delivered. Delivery of bearings in P6X and P5 should be discussed in advance.

## Internal Clearance

Single row tapered roller bearings are mounted in pairs, in which required clearance, or preload are adjusted at mounting. Clearance or preload size is determined according to arrangement's requirements.

## Misalignment

Seating surface for single row tapered roller bearings must be aligned only with small deviations because ring misalignment is very small. By common operating conditions the misalignment is

- at small load ( $F_r < 0.1C_{or}$ ) 1' to 1.5'
- at great load ( $F_r \geq 0.1C_{or}$ ) 2' to 4'

## Radial Equivalent Dynamic Load

$$\begin{array}{ll} P_r = F_r & \text{for } F_a/F_r \leq e \\ P_r = 0.4F_r + YF_a & \text{for } F_a/F_r > e \end{array} \quad \begin{array}{l} [\text{kN}] \\ [\text{kN}] \end{array}$$

Values of factors  $e$  and  $Y$  for individual bearings are shown in the dimension tables of this publication.

If the shaft is arranged in two single row tapered roller bearings additional inner axial force rises. Load magnitude of one bearing depends on load and contact angle of the second bearing. Additional inner forces must be taken into account by calculation. In the table relations for various bearing arrangements at acting outer axial force  $K_a$ , radial  $F_{rA}$ ,  $F_{rB}$  loading bearing A and B are shown.

Radial forces act in the intersection of the contact line with bearing axis (dimensions „a“, „s“ are in the dimension tables) and in calculation are considered for positive even then, when they have reverse direction than in the picture.

Calculated force  $F_a$  is introduced to the calculation of radial equivalent dynamic load.

## Radial Equivalent Static Load

$$P_{or} = 0.5F_r + Y_0F_a \quad (P_{or} \geq F_r) \quad [\text{kN}]$$

Values of  $Y_0$  factor for individual bearings are shown in the dimension tables of this publication.



Bearing Arrangement	Force Conditions	Bearing Axial Load	
		Bearing A	Bearing B
	$\frac{F_{rA}}{Y_A} \leq \frac{F_{rB}}{Y_B}$ $K_a \geq 0$	$F_{aB} = \frac{0.5 F_{rB}}{Y_B}$	$F_{aA} = F_{aB} + K_a$
	$\frac{F_{rA}}{Y_A} > \frac{F_{rB}}{Y_B}$ $K_a \geq 0.5 \left( \frac{F_{rA}}{Y_A} - \frac{F_{rB}}{Y_B} \right)$	$F_{aA} = F_{aB} + K_a$	$F_{aA} = \frac{0.5 F_{rA}}{Y_A}$
	$\frac{F_{rA}}{Y_A} > \frac{F_{rB}}{Y_B}$ $K_a \geq 0.5 \left( \frac{F_{rB}}{Y_B} - \frac{F_{rA}}{Y_A} \right)$	$F_{aA} = \frac{0.5 F_{rA}}{Y_A}$	$F_{aB} = F_{aA} - K_a$
	$\frac{F_{rA}}{Y_A} \leq \frac{F_{rB}}{Y_B}$ $K_a \geq 0$	$F_{aA} = \frac{0.5 F_{rA}}{Y_A}$	$F_{aB} = F_{aA} + K_a$
	$\frac{F_{rA}}{Y_A} < \frac{F_{rB}}{Y_B}$ $K_a \geq 0.5 \left( \frac{F_{rB}}{Y_B} - \frac{F_{rA}}{Y_A} \right)$	$F_{aA} = \frac{0.5 F_{rA}}{Y_A}$	$F_{aB} = F_{aA} + K_a$
	$\frac{F_{rA}}{Y_A} < \frac{F_{rB}}{Y_B}$ $K_a < 0.5 \left( \frac{F_{rB}}{Y_B} + \frac{F_{rA}}{Y_A} \right)^{1)}$	$F_{aA} = F_{aB} - K_a$	$F_{aB} = \frac{0.5 F_{rB}}{Y_B}$

<sup>1)</sup> Valid for  $K_a = 0$





# Single Row Tapered Roller Bearings

d = 15 to 45 mm

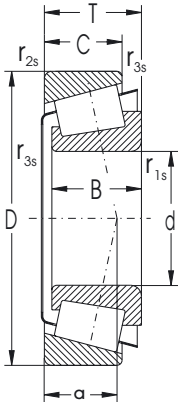

Dimensions									Basic Load Rating		Fatigue load limit $P_u$	Limiting Speed for Lubrication with	
d	D	B	C	T	$r_{1s}$ min	$r_{2s}$ min	$r_{3s}$ min	a	Dynamic $C_i$	Static $C_{or}$		Grease	Oil
mm									kN		kN	min <sup>-1</sup>	
15	42	13	11,0	14,25	1,0	1,0			21,9	19,02	2,32	10000	14000
17	47	14	12,0	15,25	1,0	1,0	0,3	11	25,1	22,80	2,78	10000	13000
20	42	15	12,0	15,00	0,6	0,6	0,3	10	22,8	29,00	3,54	9000	13000
	47	14	12,0	15,25	1,0	1,0	0,3	11	25,1	26,10	3,18	8900	12000
	52	15	13,0	16,25	1,5	1,5	0,6	11	30,4	29,90	3,65	8400	11000
	52	21	18,0	22,25	1,5	1,5	0,6	13	43,8	45,50	5,55	8400	11000
25	47	15	11,5	15,00	0,6	0,6	0,3	12	24,2	28,70	3,50	8400	11000
	52	15	13,0	16,25	1,0	1,0	0,3	12	29,9	33,50	4,09	7500	10000
	52	18	16,0	19,25	1,0	1,0			36,4	43,20	5,27	7900	11000
	52	22	18,0	22,00	1,0	1,0			48,9	58,50	7,13	7900	10000
	62	17	15,0	18,25	1,5	1,5	0,6	13	43,8	42,10	5,13	6900	9200
	62	17	15,0	18,25	1,5	1,5	0,6	13	39,8	38,30	4,67	7100	9400
	62	17	13,0	18,25	1,5	1,5	0,6	20	36,2	39,10	4,77	6700	8900
	62	24	20,0	25,25	1,5	1,5	0,6	15	57,3	60,70	7,40	6700	8900
30	55	17	13,0	17,00	1,0	1,0	0,3	13	35,5	43,80	5,34	7100	9400
	62	16	14,0	17,25	1,0	1,0	0,3	14	39,3	42,80	5,22	6500	8700
	62	16	14,0	17,25	1,0	1,0	0,3	14	40,6	44,70	5,45	6700	8900
	62	20	17,0	21,25	1,0	1,0	0,3	15	50,1	59,60	7,27	6700	8900
	72	19	16,0	20,75	1,5	1,5	0,6	15	53,1	53,10	6,48	5600	7500
	72	19	14,0	20,75	1,5	1,5	0,6	23	46,4	50,10	6,11	5300	7100
	72	27	23,0	28,75	1,5	1,5	0,6	20	76,4	85,80	10,46	5600	7500
32	58	17	13,0	17,00	1,0	1,0	0,3	14	39,8	48,20	5,88	7100	9400
35	62	18	14,0	18,00	1,0	1,0	0,3	15	43,0	53,10	6,48	6300	8400
	72	17	15,0	18,25	1,5	1,5	0,6	15	46,4	51,10	6,23	5300	7100
	72	23	19,0	24,25	1,5	1,5	0,6	17	64,3	76,40	9,32	5300	7100
	80	21	18,0	22,75	2,0	1,5	0,6	16	65,6	69,40	8,46	5000	6700
	80	21	15,0	22,75	2,0	1,5	0,6	26	57,3	63,10	7,70	4700	6300
	80	31	25,0	32,75	2,0	1,5	0,6	20	94,4	110,00	13,41	4700	6300
40	68	19	14,5	19,00	1,0	1,0	0,3	15	48,2	64,30	7,84	5300	7100
	80	18	16,0	19,75	1,5	1,5	0,6	17	55,2	60,70	7,40	4700	6300
	80	23	19,0	24,75	1,5	1,5	0,6	18	70,8	85,50	10,43	4700	6300
	90	23	20,0	25,25	2,0	1,5	0,6	18	84,3	93,20	11,37	4500	6000
	90	23	20,0	25,25	2,0	1,5	0,6	19	82,5	94,40	11,51	4500	6000
	90	23	17,0	25,25	2,0	1,5	0,6	29	76,4	85,80	10,46	4000	5300
	90	33	27,0	35,25	2,0	1,5	0,6	22	114,0	141,00	17,20	4200	5600
	90	33	27,0	35,25	2,0	1,5	0,6	27	104,2	136,60	16,66	4100	5400
	90	33	27,0	35,25	2,0	1,5	0,6	27	104,0	144,00	17,56	4200	5600
45	75	20	15,5	20,00	1,0	1,0	0,3	17	57,3	79,40	9,68	4700	6300
	85	19	16,0	20,75	1,5	1,5	0,6	18	61,9	70,80	8,63	4500	6000
	85	23	19,0	24,75	1,5	1,5	0,6	20	73,6	90,90	11,09	4500	6000
	100	25	22,0	27,25	2,0	1,5	0,6	21	107,0	118,00	14,39	4000	5300
	100	25	22,0	27,25	2,0	1,5	0,6	21	104,0	117,00	14,27	4000	5300
	100	25	18,0	27,25	2,0	1,5	0,6	32	92,6	104,00	12,68	3800	5000

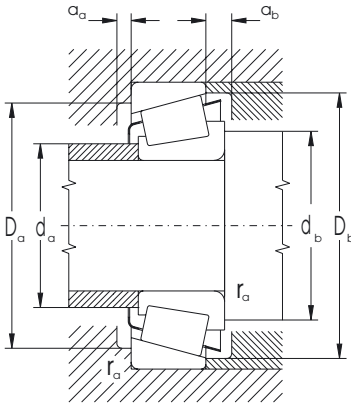

Bearing Designation		Abutment and Fillet Dimensions									Weight	Factors		
STN	ISO	d	d <sub>a</sub> max	d <sub>b</sub> min	D <sub>a</sub> min	D <sub>a</sub> max	D <sub>b</sub> min	a <sub>a</sub> min	a <sub>b</sub> min	r <sub>a</sub> max	~	e	Y	Y <sub>0</sub>
mm											kg			
30302F		15	22	21	35,0	36	38,0	2	3,0	1,0	0,100	0,32	2,11	
30303AJ2	T2FB017	17	25	23	39,0	41	42,0	2	3,0	1,0	0,140	0,29	2,10	1,20
32004AX	T3CC020	20	25	25	36,0	37	39,0	3	3,0	0,6	0,102	0,37	1,60	0,90
30204A	T2DB020	26	26	26	39,0	41	43,0	2	3,0	1,0	0,136	0,35	1,70	1,00
30304A	T2FB020	27	27	27	43,0	45	47,0	2	3,0	1,0	0,179	0,30	2,00	1,10
32304A	T2FD020	27	27	27	43,0	45	47,0	2	4,0	1,0	0,267	0,30	2,00	1,10
32005AX	T4CC025	25	30	31	40,5	42	44,0	3	3,5	0,6	0,117	0,43	1,40	0,80
30205A	T3CC025	31	31	31	43,0	46	48,0	2	3,0	1,0	0,167	0,37	1,60	0,90
32205F		31	31	31	43,0	46	48,0	2	3,0	1,0	0,200	0,36	1,03	
32305F		30	31	31	43,0	46	49,0	4	4,0	1,0	0,225	0,35	1,71	
30305A	T2FB025	33	32	32	53,0	55	57,0	2	3,0	1,0	0,288	0,30	2,00	1,10
30305AJ2	T2FB025	33	32	32	53,0	55	57,0	2	3,0	1,0	0,265	0,30	2,00	1,10
31305A	T7FB025	33	32	32	46,0	55	59,0	2	5,0	1,0	0,271	0,83	0,70	0,40
32305A	T2FD025	33	32	32	53,0	55	57,0	2	5,0	1,0	0,404	0,30	2,00	1,10
32006AX	T4CC030	30	35	36	47,5	49	52,0	3	4,0	1,0	0,181	0,43	1,40	0,80
30206A	T3DB030	37	36	36	52,0	56	57,0	2	3,0	1,0	0,252	0,37	1,60	0,90
30206AJ2	T3DB030	37	36	36	52,0	56	57,0	2	3,0	1,0	0,252	0,37	1,60	0,90
32206A	T3DC030	37	36	36	52,0	56	58,5	2	4,0	1,0	0,320	0,37	1,60	0,90
30306A	T2FB030	38	37	37	61,0	65	66,0	2	4,5	1,0	0,419	0,32	1,90	1,10
31306AJ2	T7FB030	39	37	37	55,0	65	68,0	2	6,5	1,0	0,390	0,83	0,70	0,40
32306A	T2FD030	38	37	37	61,0	65	66,0	2	5,5	1,0	0,628	0,32	1,90	1,10
320/32AX	T4CC032	32	38	38	50,0	52	55,0	3	4,0	1,0	0,196	0,45	1,30	0,70
32007AX	T4CC035	35	40	41	54,0	56	59,0	4	4,0	1,0	0,243	0,45	1,30	0,70
30207A	T3DB035	43	42	42	61,0	65	67,0	3	3,0	1,0	0,361	0,37	1,60	0,90
32207A	T3DC035	43	42	42	61,0	65	68,5	3	5,0	1,0	0,480	0,37	1,60	0,90
30307A	T2FB035	43	44	44	68,0	71	74,0	3	4,5	1,5	0,551	0,32	1,90	1,10
31307AJ2	T7FB035	43	44	44	61,0	71	76,0	3	7,5	1,5	0,520	0,83	0,70	0,40
32307A	T2FE035	43	44	44	68,0	71	74,0	3	7,5	1,5	0,827	0,32	1,90	1,10
32008AX	T3CD040	40	45	46	60,0	62	65,0	4	4,5	1,0	0,290	0,38	1,60	0,90
30208A	T3DB040	48	47	47	68,0	73	75,5	3	3,5	1,0	0,452	0,37	1,60	0,90
32208A	T3DC040	48	47	47	68,0	73	75,0	3	5,5	1,0	0,550	0,37	1,60	0,90
30308A	T2FB040	50	49	49	76,0	81	82,0	3	5,0	1,5	0,773	0,35	1,70	1,00
30308AJ2	T2FB040	50	49	49	76,0	81	82,0	3	5,0	1,5	0,773	0,35	1,70	1,00
31308A	T7FB040	50	49	49	70,0	81	86,0	3	8,0	1,5	0,776	0,83	0,70	0,40
32308A	T2FD040	50	49	49	76,0	81	82,0	3	8,0	1,5	1,120	0,35	1,70	1,00
32308BA	T5FD040	50	49	49	70,0	81	85,0	4	8,0	1,5	1,110	0,54	1,10	0,60
32308BAJ2	T5FD040	50	49	49	70,0	81	85,0	4	8,0	1,5	0,990	0,54	1,10	0,60
32009AX	T3CC045	45	50	51	66,0	69	72,0	4	4,5	1,0	0,355	0,39	1,50	0,80
30209A	T3DB045	53	52	52	73,0	78	80,0	3	4,5	1,0	0,527	0,41	1,50	0,80
32209A	T3DC045	53	52	52	73,0	78	81,5	3	5,5	1,0	0,641	0,41	1,50	0,80
30309A	T2FB045	56	54	54	85,0	91	92,0	3	5,0	1,5	1,040	0,35	1,70	1,00
30309AJ2	T2FB045	56	54	54	85,0	91	92,0	3	5,0	1,5	1,040	0,35	1,70	1,00
31309A	T7FB045	55	54	54	78,0	91	95,0	3	9,0	1,5	1,030	0,83	0,70	0,40



# Single Row Tapered Roller Bearings

d = 45 to 75 mm

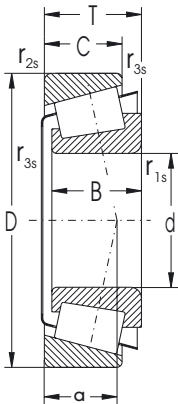

Dimensions									Basic Load Rating		Fatigue load limit $P_u$	Limiting Speed for Lubrication with	
d	D	B	C	T	$r_{1s}$ min	$r_{2s}$ min	$r_{3s}$ min	a	Dynamic $C_i$	Static $C_{or}$		Grease	Oil
mm									kN		kN	min <sup>-1</sup>	
45	100	36	30,0	38,25	2,0	1,5	0,6	25	144,0	181,0	22,07	3800	5000
	100	36	30,0	38,25	2,0	1,5	0,6	31	131,0	174,0	21,22	3800	5000
50	80	20	15,5	20,00	1,0	1,0	0,3	18	59,6	87,4	10,66	4500	6000
	90	20	17,0	21,75	1,5	1,5	0,6	20	70,8	87,4	10,66	4200	5600
	90	23	19,0	24,75	1,5	1,5	0,6	21	81,0	102,0	12,44	4200	5600
	110	27	23,0	29,25	2,5	2,0	0,6	23	121,0	141,0	17,20	3800	5000
	110	27	19,0	29,25	2,5	2,0	0,6	35	102,0	114,0	13,90	3300	4500
	110	40	33,0	42,25	2,5	2,0	0,6	27	174,0	224,0	27,32	3300	4500
55	110	40	33,0	42,25	2,5	2,0	0,6	33	156,0	212,0	25,85	3200	4400
	90	23	17,5	23,00	1,5	1,5	0,6	20	76,4	108,0	13,17	4000	5300
	100	21	18,0	22,75	2,0	1,5	0,6	21	81,0	96,2	11,73	3800	5000
	100	25	21,0	26,75	2,0	1,5	0,6	22	102,0	128,0	15,61	3800	5000
	120	29	25,0	31,50	2,5	2,0	0,6	25	136,0	162,0	19,76	3300	4500
60	120	29	21,0	31,50	2,5	2,0	0,6	38	117,0	136,0	16,59	3000	4000
	120	43	35,0	45,50	2,5	2,0	0,6	29	200,0	256,0	31,22	3300	4500
	95	23	17,5	23,00	1,5	1,5	0,6	21	81,0	119,0	14,51	3800	5000
	110	22	19,0	23,75	2,0	1,5	0,6	22	94,4	117,0	14,27	3300	4500
	110	28	24,0	29,75	2,0	1,5	0,6	25	126,0	162,0	19,76	3300	4500
	130	31	26,0	33,50	3,0	2,5	1,0	26	162,0	188,0	22,93	3000	4000
	130	31	22,0	33,50	3,0	2,5	1,0	41	136,0	158,0	19,27	2800	3800
65	130	46	37,0	48,50	3,0	2,5	1,0	31	228,0	299,0	36,46	2800	3800
	130	46	37,0	48,50	3,0	2,5	1,0	39	200,0	293,0	35,73	2500	3300
	100	23	17,5	23,00	1,5	1,5	0,6	23	81,0	123,0	15,00	3300	4500
	110	34	26,5	34,00	1,5	1,5	0,6	26	136,0	207,0	25,24	3800	5300
	120	23	20,0	24,75	2,0	1,5	0,6	24	112,0	136,0	16,59	3000	4000
	120	31	27,0	32,75	2,0	1,5	0,6	28	150,0	200,0	24,39	3000	4000
	120	41	32,0	41,00	2,0	1,5	0,6	30	191,0	267,0	32,56	3000	4000
	140	33	28,0	36,00	3,0	2,5	1,0	28	185,0	220,0	26,63	2800	3800
	140	33	23,0	36,00	3,0	2,5	1,0	44	150,0	178,0	21,55	2800	3800
70	140	48	39,0	51,00	3,0	2,5	1,0	33	261,0	331,0	40,07	2800	3800
	110	25	19,0	25,00	1,5	1,5	0,6	24	98,1	147,0	17,93	3300	4500
	125	24	21,0	26,25	2,0	1,5	0,6	26	121,0	153,0	18,66	3000	4000
	125	31	27,0	33,25	2,0	1,5	0,6	29	155,0	203,0	24,76	2800	3800
	150	35	30,0	38,00	3,0	2,5	1,0	30	211,0	251,0	29,75	2700	3500
	150	35	25,0	38,00	3,0	2,5	1,0	47	178,0	211,0	25,01	2700	3500
	150	51	42,0	54,00	3,0	2,5	1,0	36	293,0	398,0	47,17	2700	3500
75	115	25	19,0	25,00	1,5	1,5	0,6	25	104,0	158,0	19,27	3000	4000
	130	25	22,0	27,25	2,0	1,5	0,6	28	128,0	165,0	19,97	2800	3800
	130	31	27,0	33,25	2,0	1,5	0,6	30	162,0	220,0	26,63	2800	3800
	130	41	31,0	41,00	2,0	1,5	0,6	32	196,0	299,0	36,19	2800	3800
	160	37	31,0	40,00	3,0	2,5	1,0	32	242,0	287,0	33,35	2500	3300
	160	55	45,0	58,00	3,0	2,5	1,0	38	341,0	464,0	53,91	2400	3200
	160	55	45,0	58,00	3,0	2,5	1,0	47	304,0	464,0	53,91	2000	2700

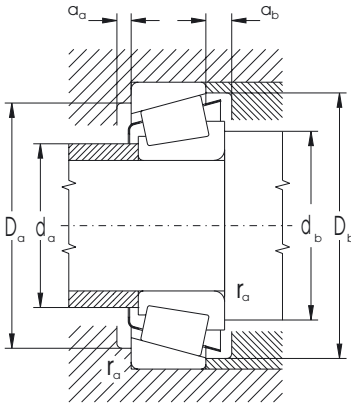

Bearing Designation		Abutment and Fillet Dimensions									Weight	Factors			
STN	ISO	d	d <sub>a</sub>	d <sub>b</sub>	D <sub>a</sub>	D <sub>a</sub>	D <sub>b</sub>	a <sub>a</sub>	a <sub>b</sub>	r <sub>a</sub>	~	e	Y	Y <sub>0</sub>	
			max	min	min	max	min	min	max	kg					
		mm										kg			
32309A	T2FD045	45	56	54	85	91	93,0	3	8,0	1,5	1,530	0,35	1,70	1,00	
32309BAJ2	T5FD045		55	54	76	91	94,0	5	8,0	1,5	1,540	0,54	1,10	0,60	
32010AX	T3CC050	50	55	56	71	74	77,0	4	4,5	1,0	0,395	0,42	1,40	0,80	
30210A	T3DB050		58	57	78	83	86,5	3	4,5	1,0	0,602	0,42	1,40	0,80	
32210A	T3DC050		58	57	78	83	85,0	3	5,5	1,0	0,667	0,42	1,40	0,80	
30310A	T2FB050		62	60	94	100	102,0	3	6,0	2,0	1,320	0,35	1,70	1,00	
31310A	T7FB050		61	60	85	100	104,0	3	10,0	2,0	1,290	0,83	0,70	0,40	
32310A	T2FD050		62	60	94	100	102,0	3	9,0	2,0	2,010	0,35	1,70	1,00	
32310BA	T5FD050		62	60	83	100	103,0	5	9,0	2,0	1,990	0,54	1,10	0,60	
32011AX	T3CC055	55	61	62	80	83	86,0	4	5,5	1,0	0,592	0,41	1,50	0,80	
30211A	T3DB055		63	64	87	91	94,0	4	4,5	1,5	0,759	0,41	1,50	0,80	
32211A	T3DC055		63	64	87	91	95,0	4	5,5	1,5	0,915	0,41	1,50	0,80	
30311A	T2FB055		67	65	103	110	111,0	4	6,5	2,0	1,710	0,35	1,70	1,00	
31311A	T7FB055		67	65	92	110	113,0	4	10,5	2,0	1,630	0,83	0,70	0,40	
32311A	T2FD055		67	65	103	110	111,0	4	10,5	2,0	2,500	0,35	1,70	1,00	
32012AX	T4CC060	60	66	67	85	88	91,0	4	5,5	1,0	0,632	0,43	1,40	0,80	
30212A	T3EB060		69	69	95	101	105,5	4	4,5	1,5	0,967	0,41	1,50	0,80	
32212A	T3EC060		69	69	95	101	104,0	4	5,5	1,5	1,270	0,41	1,50	0,80	
30312A	T2FB060		73	72	112	118	120,0	4	7,5	2,0	2,090	0,35	1,70	1,00	
31312A	T7FB060		72	72	103	118	123,0	4	11,5	2,0	2,030	0,83	0,70	0,40	
32312A	T2FD060		73	72	112	118	120,0	4	11,5	2,0	3,070	0,35	1,70	1,00	
32312B	T5FD060		73	72	99	118	122,0	6	11,5	2,0	3,160	0,54	1,10	0,60	
32013AX	T4CC065	65	71	72	90	93	97,0	4	5,5	1,0	0,675	0,46	1,30	0,70	
33113A	T3DE065		74	72	96	103	106,0	6	7,5	1,0	1,300	0,39	1,50	0,80	
30213A	T3EB065		75	74	105	111	113,0	4	4,5	1,5	1,230	0,41	1,50	0,80	
32213A	T3EC065		75	74	105	111	115,0	4	5,5	1,5	1,660	0,41	1,50	0,80	
33213A	T3EE065		75	74	102	111	115,0	6	9,0	1,5	2,060	0,39	1,50	0,90	
30313A	T2GB065		80	77	121	128	130,0	4	8,0	2,0	2,550	0,35	1,70	1,00	
31313A	T7GB065		78	77	109	128	132,0	4	13,0	2,0	2,450	0,83	0,70	0,40	
32313A	T2GD065		80	77	121	128	130,0	4	12,0	2,0	3,770	0,35	1,70	1,00	
32014AX	T4CC070	70	77	77	98	103	105,0	5	6,0	1,5	0,893	0,44	1,40	0,80	
30214A	T3EB070		80	79	108	116	118,0	4	5,0	1,5	1,370	0,42	1,40	0,80	
32214A	T3EC070		80	79	108	116	119,0	4	6,0	1,5	1,730	0,42	1,40	0,80	
30314A	T2GB070		85	82	129	138	140,0	4	8,0	2,0	3,070	0,35	1,70	1,00	
31314A	T7GB070		83	82	118	138	141,0	4	13,0	2,0	3,010	0,83	0,70	0,40	
32314A	T2GD070		85	82	129	138	140,0	4	12,0	2,0	4,550	0,35	1,70	1,00	
32015AX	T4CC075	75	82	82	103	108	110,0	5	6,0	1,0	0,955	0,46	1,30	0,70	
30215A	T4DB075		85	84	113	121	124,0	4	5,0	1,5	1,470	0,44	1,40	0,80	
32215A	T4DC075		85	84	113	121	121,0	4	6,0	1,5	1,820	0,44	1,40	0,80	
33215A	T3EE075		85	84	111	121	125,0	6	10,0	1,5	2,300	0,43	1,40	0,80	
30315A	T2GB075		91	87	138	148	149,0	4	9,0	2,0	3,720	0,35	1,70	1,00	
32315A	T2GD075		91	87	138	148	149,0	4	13,0	2,0	5,620	0,35	1,70	1,00	
32315B	T5GD075		90	87	128	148	150,0	7	12,5	2,0	5,600	0,54	1,10	0,60	



# Single Row Tapered Roller Bearings

d = 80 to 140 mm

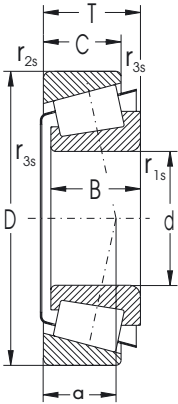

Dimensions									Basic Load Rating		Fatigue load	Limiting Speed	
d	D	B	C	T	r <sub>1s</sub>	r <sub>2s</sub>	r <sub>3s</sub>	a	Dynamic C <sub>r</sub>	Static C <sub>or</sub>	limit P <sub>u</sub>	for Lubrication with Grease Oil	
mm									kN		kN	min <sup>-1</sup>	
80	125	29	22,0	29,00	1,5	1,5	0,6	27	131,0	207,0	25,06	2800	3800
	130	37	29,0	37,00	2,0	1,5	0,6	31	190,0	300,0	36,05	3200	4200
	140	26	22,0	28,25	2,5	2,0	0,6	29	144,0	178,0	21,10	2800	3800
	140	33	28,0	35,25	2,5	2,0	0,6	32	181,0	251,0	29,75	2800	3800
85	130	29	22,0	29,00	1,5	1,5	0,6	28	136,0	215,0	25,66	2800	3800
	130	36	29,5	36,00	1,5	1,5	0,6	26	195,0	319,0	38,07	3000	4000
	150	28	24,0	30,50	2,5	2,0	0,6	30	181,0	207,0	24,05	2700	3500
	150	36	30,0	38,50	2,5	2,0	0,6	34	212,4	290,2	33,72	2400	3300
	150	36	30,0	38,50	2,5	2,0	0,6	34	237,0	293,0	34,04	2700	3500
	150	49	37,0	49,00	2,5	2,0	0,6	37	278,0	418,0	48,57	2200	3200
90	140	32	24,0	32,00	2,0	1,5	0,6	30	150,0	228,0	26,66	2700	3500
	140	39	32,5	39,00	2,0	1,5	0,6	28	223,0	370,0	43,27	2800	3800
	150	45	35,0	45,00	2,5	2,0	0,6	36	265,0	420,0	48,49	2800	3800
	160	30	26,0	32,50	2,5	2,0	0,6	31	185,0	242,0	27,60	2400	3200
	160	40	34,0	42,50	2,5	2,0	0,6	37	251,0	355,0	40,49	2400	3200
95	145	32	24,0	32,00	2,0	1,5	0,6	31	174,0	280,0	32,33	2700	3500
	145	39	32,5	39,00	2,0	1,5	0,6	29	228,0	385,0	44,45	2700	3500
	170	32	27,0	34,50	3,0	2,5	1,0	33	214,0	272,0	30,49	2000	2900
	170	43	37,0	45,50	3,0	2,5	1,0	38	310,0	437,0	48,98	2700	3500
100	150	32	24,0	32,00	2,0	1,5	0,6	33	178,0	261,0	29,77	2800	3800
	150	39	32,5	39,00	2,0	1,5	0,6	29	234,0	400,0	45,62	2500	3300
	180	34	29,0	37,00	3,0	2,5	1,0	37	266,0	346,0	38,14	2500	3300
	180	46	39,0	49,00	3,0	2,5	1,0	41	348,0	496,0	54,68	2500	3300
105	160	35	26,0	35,00	2,5	2,0	0,6	35	205,0	337,0	37,77	2600	3400
	160	43	34,0	43,00	2,5	2,0	0,6	31	260,0	445,0	49,87	2400	3200
	190	36	30,0	39,00	3,0	2,5	1,0	37	293,0	387,0	42,00	2400	3200
	190	50	43,0	53,00	3,0	2,5	1,0	44	393,0	570,0	61,86	2400	3200
110	170	38	29,0	38,00	2,5	2,0	0,6	37	246,0	390,0	42,99	2500	3300
	170	47	37,0	47,00	2,5	2,0	0,6	33	300,0	520,0	57,33	2200	3000
	200	38	32,0	41,00	3,0	2,5	1,0	39	304,0	402,0	42,98	1800	2500
	200	53	46,0	56,00	3,0	2,5	1,0	46	433,0	630,0	67,36	2200	3000
120	180	38	29,0	38,00	2,5	2,0	0,6	40	254,0	430,0	46,43	2400	3200
	215	40	34,0	43,50	3,0	2,5	1,0	43	339,0	452,0	47,22	1600	2200
	215	58	50,0	61,50	3,0	2,5	1,0	52	462,0	685,0	71,56	1600	2200
130	200	45	34,0	45,00	2,5	2,0	0,6	43	330,0	560,0	58,77	2100	2800
140	210	45	34,0	45,00	2,5	2,0	0,6	46	335,0	580,0	59,80	1700	2200

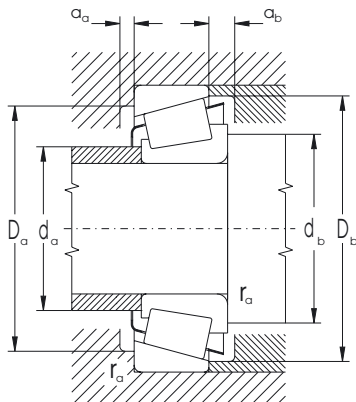

Bearing Designation		Abutment and Fillet Dimensions									Weight	Factors		
STN	ISO	d	d <sub>a</sub> max	d <sub>b</sub> min	D <sub>a</sub> min	D <sub>a</sub> max	D <sub>b</sub> min	a <sub>a</sub> min	a <sub>b</sub> min	r <sub>a</sub> max	~	e	Y	Y <sub>0</sub>
mm											kg			
32016AX	T3CC080	80	87	87	112	118	120,0	6	7,0	1,0	1,320	0,42	1,40	0,80
33116A	T3DE080		89	89	114	121	126,0	6	8,0	1,5	1,930	0,42	1,40	0,80
30216A	T3EB080		90	90	122	130	132,0	4	6,0	2,0	1,750	0,42	1,40	0,80
32216A	T3EC080		90	90	122	130	134,0	4	7,0	2,0	2,290	0,42	1,40	0,80
32017AX	T4CC085	85	92	92	117	123	125,0	6	7,0	1,0	1,410	0,44	1,40	0,70
33017A	T2CE085		92	93	117	123	125,0	6	6,5	1,0	1,730	0,29	2,10	1,10
30217A	T3EB085		96	95	132	140	141,0	5	6,0	2,0	2,140	0,42	1,40	0,80
32217A	T3EC085		96	95	130	140	142,0	5	8,5	2,0	2,850	0,42	1,40	0,80
32217AJ2	T3EC085		96	95	130	140	142,0	5	8,5	2,0	2,850	0,42	1,40	0,80
33217A	T3EE085		96	95	128	140	144,0	7	12,0	2,0	3,690	0,42	1,40	0,80
32018AX	T3CC090	90	99	99	124	131	134,0	6	8,0	1,5	1,780	0,42	1,40	0,80
33018A	T2CE090		99	99	124	131	135,0	6	6,5	1,5	2,250	0,27	2,20	1,20
33118A	T3DE090		101	100	130	140	144,0	7	10,0	2,0	3,200	0,40	1,50	0,80
30218A	T3FB090		102	100	138	150	150,0	5	6,0	2,0	2,710	0,42	1,40	0,80
32218A	T3FC090		102	100	138	150	152,0	5	8,5	2,0	3,600	0,42	1,40	0,80
32019AX	T4CC095	95	105	104	130	136	139,0	6	8,0	1,5	1,870	0,44	1,40	0,80
33019A	T2CE095		103	104	130	136	139,0	6	6,5	1,5	2,340	0,28	2,10	1,20
30219A	T3FB095		107	110	148	158	159,0	5	7,0	2,0	3,160	0,42	1,40	0,80
32219A	T3FC095		107	110	148	158	161,0	5	10,0	2,0	4,320	0,42	1,40	0,80
32020AX	T4CC100	100	109	109	134	141	144,0	6	8,0	1,5	1,940	0,46	1,30	0,70
33020A	T2CE100		109	110	134	141	144,0	6	6,5	1,5	2,470	0,28	2,10	1,10
30220A	T3FB100		114	112	155	168	168,0	5	8,0	2,0	3,810	0,42	1,40	0,80
32220A	T3FC100		114	112	155	168	171,0	5	10,0	2,0	5,210	0,42	1,40	0,80
32021AX	T4DC105	105	116	115	143	150	154,0	6	9,0	2,0	2,510	0,44	1,40	0,70
33021A	T2DE105		116	116	143	150	153,0	6	9,0	2,0	3,060	0,28	2,10	1,20
30221A	T3FB105		120	117	163	178	178,0	8	9,0	2,0	4,940	0,42	1,40	0,80
32221A	T3FC105		120	117	163	178	178,0	6	10,0	2,0	6,380	0,42	1,40	0,80
32022AX	T4DC110	110	120	120	152	160	163,0	6	9,0	2,0	3,090	0,43	1,40	0,80
33022A	T2DE110		121	121	150	159	160,0	6	10,0	2,0	3,870	0,29	2,10	1,20
30222A	T3FB110		125	122	171	188	187,0	8	9,0	2,0	5,320	0,44	1,40	0,80
32222A	T3FC110		125	122	171	188	190,0	6	10,0	2,0	7,560	0,44	1,40	0,80
32024AX	T4DC120	120	130	130	162	170	173,0	6	9,0	2,0	3,320	0,46	1,30	0,70
30224A	T4FB120		135	132	187	203	201,0	9	9,0	2,0	6,330	0,44	1,40	0,80
32224A	T4FD120		135	132	184	203	204,0	9	11,5	2,0	9,420	0,44	1,40	0,80
32026AX	T4EC130	130	140	140	178	190	192,0	8	11,0	2,0	5,050	0,44	1,40	0,80
32028AX	T4DC140	140	150	150	186	200	202,0	8	11,0	2,0	5,260	0,46	1,30	0,70

# Single Row Tapered Roller Bearings in Inch Dimensions

d = 15.875 to 38.100 mm

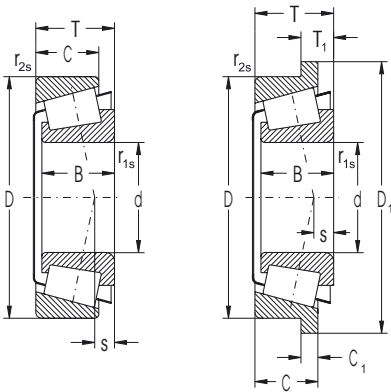

Dimensions											Basic Load Rating		Fatigue	Limiting Speed	
d	D	D <sub>i</sub>	B	C	C <sub>1</sub>	T	T <sub>1</sub>	r <sub>1s</sub>	r <sub>2s</sub>	s	C <sub>i</sub>	C <sub>cr</sub>	load limit	for Lubrication with	
											C <sub>i</sub>	C <sub>cr</sub>	P <sub>u</sub>	Grease	Oil
mm											kN		kN	min <sup>-1</sup>	
15.88	42.86		14.288	9.525		14.288		1.50	1.50	1.30	17.30	18.60	2.27	9500	14000
16.00	47.00		21.000	16.000		21.000		1.00	2.00	6.00	36.90	40.60	4.95	8400	11000
17.46	39.88		14.605	10.670		13.843		1.30	1.30	4.80	21.10	21.50	2.62	10000	13000
19.05	45.24		16.637	12.065		15.494		1.30	1.30	5.60	25.60	26.60	3.24	8900	12000
21.99	45.24		16.637	12.065		15.494		1.20	1.20	5.30	28.70	29.90	3.65	8400	11000
22.00	45.00	51.5	16.637	12.065	3.000	15.494	6.43	1.20	1.20	5.40	28.70	29.90	3.65	8400	11000
25.40	50.29		14.732	10.668		14.224		1.30	1.30	3.30	24.60	28.70	3.50	7500	10000
	* 50.29		14.732	10.668		14.224		1.30	1.30	3.30	24.60	28.70	3.50	7500	10000
			59.93	23.114	18.288	23.368		0.80	1.57	5.10	44.70	66.80	8.15	5600	7500
26.99	50.29		14.732	10.668		14.224		3.56	1.30	3.30	24.60	28.70	3.50	7500	10000
29.00	50.29		14.732	10.668		14.224		3.60	1.20	3.20	25.60	33.50	4.09	7100	9400
30.00	62.00	68.5	18.100	15.536	3.556	17.250	5.27	1.00	1.50	3.30	44.70	44.70	5.45	6700	8900
30.16	64.29		21.433	16.670		21.433		1.57	1.57	3.30	44.70	59.60	7.27	5600	7500
31.75	59.13		16.764	11.811		15.875		4.75	1.30	2.90	31.60	38.30	4.67	6700	8900
	62.00		19.050	14.288		18.161		4.75	1.30	5.20	47.30	58.40	7.12	6300	8400
34.93	65.09		18.288	13.970		18.034		4.75	1.30	3.70	43.00	53.10	6.48	5600	7500
	73.03		24.608	19.050		23.813		3.56	2.36	6.60	57.30	76.40	9.32	5300	6700
35.00	60.00		16.764	11.938		15.875		4.75	1.30	2.50	31.60	42.20	5.15	6300	8400
38.00	63.00		17.000	13.500		17.000		1.50	1.50	2.30	42.20	55.20	6.73	6700	8900
38.10	65.09		18.288	13.970		18.034		2.30	1.10	5.00	49.20	60.70	7.40	5600	7500



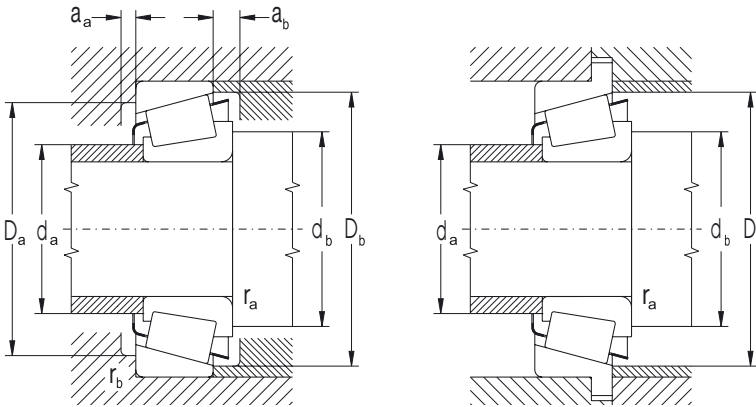

Bearing Designation Cone/ Cup	Abutment and Fillet Dimensions										Weight ~	Dimension Deviations						Factors		
	$d_a$ max	$d_b$ min	$D_a$ min	$D_b$ max	$D_b$ min	$a_a$ min	$a_b$ min	$r_a$ max	$r_b$ max	$r_b$ max		$\Delta d_{mp}$ max	$\Delta d_{mp}$ min	$\Delta D_{mp}$ max	$\Delta D_{mp}$ min	$\Delta T_s$ max	$\Delta T_s$ min	e	Y	$Y_0$
	mm										kg	$\mu m$								
K-11590/ K-11520	22.5	24.5	34.5	35.0	39.5	2.0	4.5	1.5	1.5	1.5	0.063	+13	0	+25	0	+200	0	0.70	0.90	0.50
K-HM81649/ K-HM81610	23.0	22.0	36.0	39.0	43.0	2.0	4.0	1.0	1.5	1.5	0.199	0	-13	0	-25	+200	0	0.55	1.10	0.60
K-LM11749/ K-HM11710	23.0	24.0	33.5	35.0	37.0	2.0	3.0	1.0	1.0	1.0	0.186	+13	0	+15	0	+200	0	0.29	2.10	1.20
K-LM11949/ K-LM11910	25.0	25.5	38.0	38.5	41.0	3.0	3.0	1.0	1.0	1.0	0.121	+20	0	+25	0	+356	0	0.30	2.00	1.10
K-LM12749/ K-LM12710	26.0	27.5	38.0	38.5	42.5	3.0	3.0	1.2	1.2	1.2	0.119	+13	0	0	+15	+200	0	0.31	1.96	1.00
K-LM12749/ K-LM12712B	26.0	27.5	-	-	46.0	1.2	3.5	1.3	-	-	0.129	-13	0	0	-15	+200	0	0.31	1.96	1.10
K-L44643/ K-L44610	33.0	32.0	43.5	43.5	47.0	2.0	3.5	1.0	1.0	1.0	0.128	+13	0	+25	0	+200	0	0.37	1.60	0.90
K-L44643/ K-L44610/ K-L44600LA	33.0	32.0	43.5	43.5	-	2.0	-	1.0	1.0	1.0	0.130	+13	0	+25	0	+200	0	0.37	1.60	0.90
K-M84249/ K-M84210	33.0	32.0	46.0	53.0	56.0	3.0	4.5	0.6	1.0	1.0	0.327	+13	0	+25	0	+200	0	0.55	1.10	0.60
K-L44649/ K-L44610	33.0	38.0	43.5	45.0	47.0	3.0	3.5	3.0	1.0	1.0	0.120	+20	0	+25	0	+356	0	0.37	1.60	0.90
K-L45449/ K-L45410	34.0	40.0	43.5	45.0	47.0	3.0	3.5	3.0	1.0	1.0	0.113	+13	0	+15	0	+200	0	0.37	1.60	0.90
K-JXC25640CB/ K-JXC25640D	34.5	37.0	-	-	59.0	1.2	1.7	1.5	-	-	0.269	0	-12	+20	0	+200	0	0.37	1.60	0.90
K-M86649/ K-M86610	38.0	38.0	51.0	56.5	60.0	3.0	4.5	1.0	1.0	1.0	0.341	+13	0	+25	0	+200	0	0.55	1.10	0.60
K-LM67048/ K-LM67010	38.0	44.5	51.0	52.0	55.0	3.0	4.0	3.0	1.0	1.0	0.180	+13	0	+25	0	+356	0	0.41	1.50	0.80
K-15123/ K-15245	38.0	43.5	54.0	55.0	58.0	4.0	3.5	3.0	1.0	1.0	0.248	+13	0	+25	0	+203	0	0.35	1.70	0.90
K-LM48548/ K-LM48510	42.0	47.0	57.0	58.0	61.0	3.0	4.0	3.0	1.0	1.0	0.244	+20	0	+25	0	+356	0	0.38	1.60	0.90
PLC65-3	43.0	45.0	62.0	64.0	68.0	3.0	3.0	5.0	2.0	2.0	0.495	+13	0	+25	0	+200	0	0.37	1.60	0.90
K-L68149/ K-L68111	40.0	46.0	52.0	54.0	56.0	3.0	3.5	3.0	1.0	1.0	0.176	0	-20	0	-25	+356	0	0.42	1.40	0.80
K-JL69349/ K-JL69310	41.0	49.0	56.5	57.0	60.0	1.5	3.5	1.5	1.5	1.5	0.204	+13	0	+25	0	+200	0	0.42	1.44	0.79
K-LM29749/ K-LM29710	42.5	46.0	58.0	60.0	62.0	4.0	4.0	2.3	1.3	1.3	0.240	+13	0	+25	0	+200	0	0.33	1.80	1.00



## Single Row Tapered Roller Bearings in Inch Dimensions

$d = 39.688$  to  $146.05$  mm

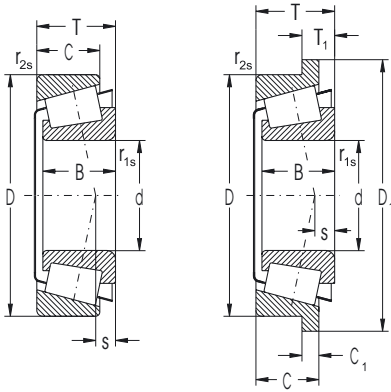

Dimensions										Basic Load Rating		Fatigue	Limiting Speed		
d	D	D <sub>1</sub>	B	C	C <sub>1</sub>	T	T <sub>1</sub>	r <sub>1s</sub> min	r <sub>2s</sub> min	s	C <sub>i</sub>	C <sub>0r</sub>	P <sub>u</sub>	for Grease	Oil
mm											kN	kN	kN	min <sup>-1</sup>	
39.69	80.17	30.391	23.813	29.370	0.80	3.20	11.10	81.00	104.00	12.68	4200	5600			
40.00	80.00	22.403	17.826	21.000	0.80	1.30	6.00	70.80	73.60	8.98	4700	6300			
40.10	67.98	18.000	13.500	17.500	3.60	1.50	3.60	47.30	59.60	7.27	5300	7100			
44.45	83.06	25.400	19.050	23.813	3.56	3.20	6.10	59.60	87.40	10.66	4200	5600			
45.24	77.79	19.842	15.800	19.842	1.00	1.00	2.30	59.60	77.90	9.50	4900	6500			
50.00	82.00	21.500	17.000	21.500	3.00	0.50	5.30	75.20	104.00	12.68	4500	6000			
50.80	101.60	36.068	29.988	34.925	0.80	3.20	12.70	123.00	162.00	19.76	3200	4200			
57.15	127.00	44.450	34.925	44.450	3.50	3.30	9.40	228.00	276.00	33.66	3000	4000			
65.00	110.00	28.000	22.500	28.000	3.00	2.50	4.00	133.00	188.00	22.93	3300	4500			
88.90	152.40	39.688	30.162	39.688	6.40	3.30	35.00	230.00	344.00	39.65	2000	3000			
89.97	146.98	40.000	32.500	40.000	7.00	3.50	31.00	243.00	365.00	42.30	2400	3300			
90.00	145.00	34.000	27.000	35.000	6.00	2.50	33.00	213.00	315.00	36.60	2200	3200			
146.05	193.68	28.575	23.020	28.575	5.80	1.50	34.00	181.00	390.00	40.57	1700	2200			



# Single Row Tapered Roller Bearings in Inch Dimensions

d = 15,875 to 39,688 mm

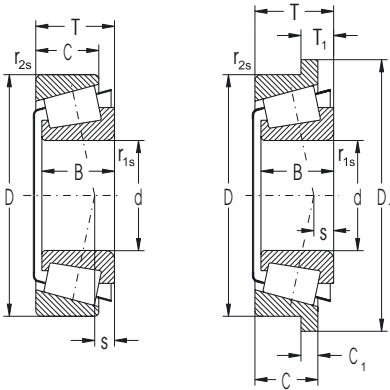

Dimensions											Basic Load Rating		Fatigue	Limiting Speed	
d	D	D <sub>1</sub>	B	C	C <sub>1</sub>	T	T <sub>1</sub>	r <sub>1s</sub>	r <sub>2s</sub>	s	C <sub>i</sub>	C <sub>cr</sub>	P <sub>u</sub>	for Grease	for Oil
											min	min			
mm											kN		kN	min <sup>-1</sup>	
15.875	42.862		14.288	9.525		14.288		1.5	1.5		17.8	17.7	2.16	10000	14000
19.050	49.225		19.050	14.288		18.034		1.3	1.3		37.7	37.7	4.60	8900	12000
	49.225		19.050	17.462		21.209		1.3	1.5		37.7	37.7	4.60	8900	12000
	49.225		21.539	14.288		19.845		1.5	1.3		37.7	37.7	4.60	8900	12000
25.400	57.150		19.431	14.732		19.431		1.5	1.5		44.9	52.9	6.45	6400	8600
	62.000		20.638	15.875		19.050		0.8	1.3		44.6	50.7	6.18	6400	8600
	63.500		20.638	15.875		20.638		0.8	1.5		44.6	50.7	6.18	6400	8600
26.988	62.000		20.638	14.288		19.050		0.8	1.3		44.6	50.7	6.18	6400	8600
28.575	68.262		22.225	17.462		22.225		0.8	1.5		51.0	61.1	7.45	6000	8000
	73.025		22.225	17.462		22.225		0.8	3.3		55.0	65.7	8.01	5500	7400
29.000	50.292		14.732	10.668		14.224		3.5	1.3		28.9	37.2	4.54	7600	10000
30.162	64.292		21.433	16.670		21.433		1.5	1.5		55.2	70.7	8.62	6400	8500
30.213	62.000		20.638	14.288		19.050		3.5	1.3		44.6	50.7	6.18	6400	8600
31.750	59.131		16.764	11.811		15.875			1.2		35.8	43.1	5.26	6600	8800
	62.000		20.638	14.288		19.050		0.8	1.3		44.6	50.7	6.18	6400	8600
	63.500		19.050	15.875		20.638			1.5		44.6	50.7	6.18	6400	8600
	69.012		19.583	15.875		19.845		3.5	3.3		46.1	55.0	6.71	5900	7800
33.338	68.262		22.225	17.462		22.225		0.8	1.5		56.1	71.1	8.67	6000	7900
34.925	69.012		19.583	15.875		19.845		3.5	3.3		46.1	55.0	6.71	5900	7800
	69.012		19.583	15.875		19.845		3.5	1.3		46.1	55.0	6.71	5900	7800
	72.233		25.400	19.842		25.400		2.3	2.3		66.9	87.4	10.66	5700	7600
	73.025		24.608	19.050		23.812		1.5	2.3		72.2	87.3	10.65	5600	7400
	73.025		24.608	19.050		23.812		1.5	0.8		72.2	87.3	10.65	5600	7400
	76.200		28.575	23.812		29.370		1.5	3.3		80.9	97.4	11.88	5400	7200
	34.988	61.973		17.000	13.600		16.700			1.5	39.4	52.4	6.39	5600	7500
35.000	59.975		18.412	11.938		15.875		2.5	1.3		36.0	48.6	5.93	6400	8500
	65.000		20.600	17.000		18.100		2.3	1.3		45.7	53.1	6.48	5500	7400
36.487	76.200		25.654	19.050		23.812		1.5	3.3		81.1	105.0	12.80	5000	6700
36.512	76.200		28.575	23.020		29.370		3.5	3.3		79.5	107.0	13.05	5400	7200
38.100	65.088		18.288	13.970		18.034			1.3		42.9	56.5	6.89	5800	7800
	65.088		18.288	13.970		18.034		2.3	1.3		42.9	56.5	6.89	5800	7800
	65.088		18.288	15.748		19.812		2.3	1.3		42.9	56.5	6.89	5800	7800
	69.012		19.050	15.083		19.050		3.5	2.3		49.2	62.0	7.56	5600	7500
	76.200		25.654	19.050		23.812		3.5	3.3		81.1	105.0	12.80	5000	6700
	82.550		28.575	23.020		29.370		0.8	3.3		87.3	117.0	14.27	4900	6600
	88.500		29.083	22.225		26.988		3.5	1.5		98.2	112.0	13.66	4900	6500
	39.688	73.025		22.098	18.500		19.395		2.3	1.3		53.0	66.3	8.09	5200
79.967			22.098	22.091		19.395		2.3	1.3		66.3	53.0	6.46	5200	6900

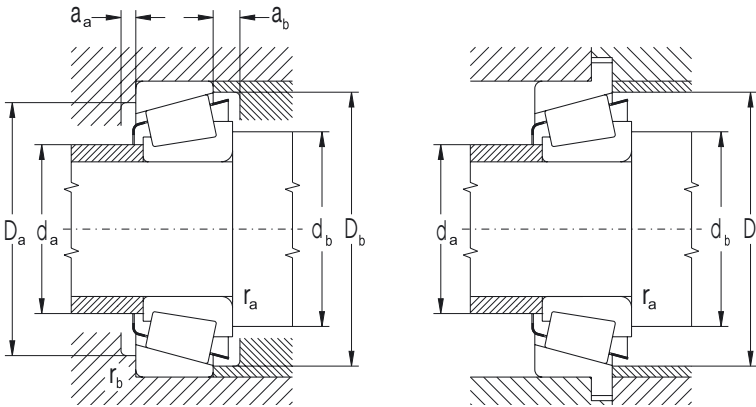

Bearing Designation Cone/ Cup	Abutment and Fillet Dimensions										Weight ~	Dimension Deviations						Factors		
	d <sub>a</sub>	d <sub>b</sub>	D <sub>a</sub>	D <sub>a</sub>	D <sub>b</sub>	a <sub>a</sub>	a <sub>b</sub>	r <sub>a</sub>	r <sub>b</sub>			Δdmp		ΔDmp		ΔTs		e	Y	Y <sub>0</sub>
	max	min	min	max	min	min	min	max	max			max	min	max	min	max	min			
	mm										kg	μm								
11590/11520	22.5	24.5	34.5		39.5	2.0	4.5	1.5	1.5	0.10	+13	0	+25	0	+203	0	0.70	0.85	1.20	
09067/09195	24.0	25.5	42.0		44.5	4.0	4.5	1.3	1.3	0.17	+13	0	+25	0	+203	0	0.27	2.26		
09067/09196	24.0	25.5	41.5		44.5	1.0	4.5	1.3	1.5	0.19	+13	0	+25	0	+203	0	0.27	2.26	1.20	
09074/09195	24.0	26.0	42.0		44.5	4.0	4.5	1.5	1.3	0.18	+13	0	+25	0	+203	0	0.27	2.26		
M84548/84510	33.0	36.0	48.5		54.0	2.5	5.0	1.5	1.5	0.23	+13	0	+25	0	+203	0	0.55	1.10	1.00	
15101/15245	31.5	32.5	55.0		58.0	5.0	5.0	0.8	1.3	0.29	+13	0	+25	0	+203	0	0.35	1.71		
15101/15250X	31.5	32.5	55.0		59.0	3.0	5.0	0.8	1.5	0.32	+13	0	+25	0	+203	0	0.35	1.71	1.00	
15106/15245	33.0	33.5	55.0		58.0	5.0	5.0	0.8	1.3	0.28	+13	0	+25	0	+203	0	0.35	1.71		
02474/0220	36.0	36.5	59.0		63.0	3.0	5.5	0.8	1.5	0.40	+13	0	+25	0	+203	0	0.42	1.44	0.77	
02872/02820	37.0	37.5	62.0		68.0	3.0	5.0	0.8	3.3	1.04	+13	0	+25	0	+203	0	0.45	1.32		
F15029/L45410	33.0	39.5	44.5		48.0	4.0	3.5	4.0	3.5	0.11	+13	0	+25	0	+203	0	0.37	1.62	1.08	
M86649/86610	38.2	41.0	54.0		61.0	3.0	5.3	1.5	1.5	0.33	+13	0	+25	0	+203	0	0.55	1.10		
15118/15245	35.5	41.5	55.0		58.0	5.0	5.0	3.5	1.3	0.26	+13	0	+25	0	+203	0	0.35	1.71	1.20	
LM67048 RS	36.0	42.5	52.0		56.0	4.5	3.5		1.2	0.17	+13	0	+25	0	+203	0	0.41	1.46		
/67010																			0.70	
151126/15245	36.5	37.0	55.0		58.0	5.0	5.0	0.8	1.3	0.25	+13	0	+25	0	+203	0	0.35	1.71		
15123/15250X	31.5	32.5	55.0		59.0	3.0	5.0	0.8	1.5	0.32	+13	0	+25	0	+203	0	0.35	1.71	0.90	
14125A/14274	40.0	46.0	60.0		63.0	3.0	4.5	3.5	1.3	0.32	+13	0	+25	0	+203	0	0.38	1.57		
M88048/88010	41.0	42.5	58.0		65.0	3.0	4.0	0.8	1.5	0.37	+13	0	+25	0	+203	0	0.55	1.10	0.74	
14138A/14274	40.0	46.0	60.0		63.0	3.0	4.5	3.5	1.3	0.32	+13	0	+25	0	+203	0	0.38	1.57		
14138A/14276	40.0	46.0	60.0		63.0	3.0	4.5	3.5	1.3	0.32	+13	0	+25	0	+203	0	0.38	1.57	0.99	
HM88649	42.5	48.5	60.0		69.0	4.0	5.5	2.3	2.3	0.50	+13	0	+25	0	+203	0	0.55	1.10		
/88610																			0.74	
25877/25820	40.5	43.0	64.0		68.0	4.5	5.5	1.5	2.3	0.46	+13	0	+25	0	+203	0	0.29	2.07		
25877/25821	40.5	43.0	65.0		68.0	4.5	5.5	1.5	0.8	0.46	+13	0	+25	0	+203	0	0.29	2.07	0.90	
31594/31520	43.5	46.0	64.0		72.0	2.5	6.0	1.5	3.3	0.62	+13	0	+25	0	+203	0	0.40	1.49		
LM78349	40.0	46.0	54.0		59.0	3.0	4.0		1.5	0.19	0	-13	0	-25	+203	0	0.44	1.35		
/78310A																				
F15036	45.5	39.0	53.0		56.0	4.0	3.0	2.5	1.3	0.19	+13	0	+25	0	+203	0	0.42	1.44		
/JL68111Z																				
U298/U261+collar																				
2780/2720	42.5	44.5	66.0		70.0	5.0	5.0	1.5	3.3	0.52	+13	0	+25	0	+203	0	0.30	1.98		
HM89449/89410	44.5	54.0	62.0		73.0	3.0	5.5	3.5	3.3	0.62	+13	0	+25	0	+203	0	0.55	1.10		
LM29748/29710	42.5	49.0	59.0		62.0	3.0	4.5		1.3	0.22	+13	0	+25	0	+203	0	0.33	1.80		
LM29749/29710	42.5	46.0	59.0		62.0	3.0	4.5	2.3	1.3	0.22	+13	0	+25	0	+203	0	0.33	1.80		
LM29749/29711	42.5	46.0	58.0		62.0	1.5	4.5	2.3	1.3	0.24	+13	0	+25	0	+203	0	0.33	1.80		
13685/13621	43.0	49.5	61.0		65.0	2.5	4.0	3.5	2.3	0.28	+13	0	+25	0	+203	0	0.40	1.49		
2788/2720	43.5	50.0	66.0		70.0	5.0	5.0	3.5	3.3	0.49	+13	0	+25	0	+203	0	0.30	1.98		
HM801346	49.1	51.0	68.0		78.0	3.0	6.0	0.8	3.3	0.76	+13	0	+25	0	+203	0	0.55	1.10		
/801310																				
418/414	44.5	51.0	77.0		80.0	5.0	6.0	3.5	1.5	0.82	+13	0	+25	0	+203	0	0.26	2.28		
U399/U360+collar																				
U399/U365+collar																				



# Single Row Tapered Roller Bearings in Inch Dimensions

d = 40.988 to 50.800 mm

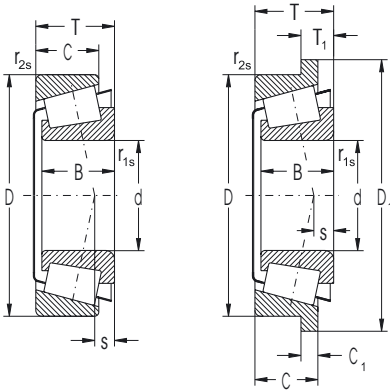

Dimensions											Basic Load Rating		Fatigue	Limiting Speed	
d	D	D <sub>1</sub>	B	C	C <sub>1</sub>	T	T <sub>1</sub>	r <sub>1s</sub>	r <sub>2s</sub>	s	C <sub>i</sub>	C <sub>cr</sub>	load limit P <sub>u</sub>	for Grease	for Oil
											kN		kN	min <sup>-1</sup>	
mm															
40.988	67.975	18.000	13.500	17.500	17.500	17.500	17.500	**	1.5		46.1	63.5		5400	7200
41.275	73.025	17.462	12.700	16.667	16.667	16.667	16.667	3.5	1.5		45.9	55.8	6.80	5200	6900
	73.431	19.812	14.732	19.558	19.558	19.558	19.558	3.5	0.8		57.8	73.0	8.90	5200	7000
	73.431	19.812	16.604	21.430	21.430	21.430	21.430	3.5	0.8		57.8	73.0	8.90	5200	7000
	76.200	23.020	17.462	22.225	22.225	22.225	22.225	3.5	0.8		66.3	83.3	10.16	5200	6900
	87.312	30.886	23.812	30.162	30.162	30.162	30.162	1.5	3.3		95.8	120.0	14.63	4600	6200
88.900	29.370	23.020	30.162	30.162	30.162	30.162	3.5	3.3		99.6	125.0	15.24	4600	6100	
42.875	82.931	25.400	19.050	23.812	23.812	23.812	23.812	3.5	0.8		77.2	100.0	12.20	4800	6300
	82.931	25.400	22.225	26.988	26.988	26.988	26.988	3.5	2.3		77.2	100.0	12.20	4800	6300
	83.058	25.400	19.050	23.812	23.812	23.812	23.812	3.5	3.3		77.2	100.0	12.20	4800	6300
44.450	104.775	36.512	28.575	36.512	36.512	36.512	36.512	3.5	3.3		141.0	195.0	23.78	3800	5100
	83.058	25.400	19.114	23.876	23.876	23.876	23.876	3.5	2.0		77.2	100.0	12.20	4800	6300
	88.900	29.370	23.020	30.162	30.162	30.162	30.162	3.6	3.2		99.6	125.0	15.24	4600	6100
	93.264	30.302	23.812	30.162	30.162	30.162	30.162	3.5	3.3		103.0	137.0	16.71	4200	5500
	95.250	28.575	22.225	30.958	30.958	30.958	30.958	3.5	0.8		99.7	120.0	14.63	3700	5100
45.000	80.000	26.000	22.000	24.000	24.000	24.000	2.3	1.3		61.2	79.0	9.63	4500	6100	
45.230	79.985	20.638	15.080	19.842	19.842	19.842	2.0	1.3		62.0	78.5	9.57	4800	6400	
45.242	73.431	19.812	15.748	19.558	19.558	19.558	19.558	3.5	0.8		55.6	78.1	9.52	5100	6700
	77.788	19.842	15.080	19.842	19.842	19.842	19.842	3.6	0.8		57.1	73.5	8.96	4900	6500
	77.788	19.842	16.667	21.430	21.430	21.430	21.430	3.6	0.8		57.1	73.5	8.96	4900	6500
45.618	82.931	25.400	22.225	26.988	26.988	26.988	3.5	2.3		77.2	100.0	12.20	4800	6300	
45.987	74.976	18.000	14.000	18.000	18.000	18.000	2.3	1.5		52.6	74.6	9.10	5000	6600	
46.038	79.375	17.462	13.495	17.462	17.462	17.462	2.8	1.5		47.1	59.1	7.21	4800	6400	
50.000	82.000	21.500	17.000	21.500	21.500	21.500	3.0	0.5		71.7	97.9	11.94	4500	6000	
50.800	104.775	36.512	28.575	36.512	36.512	36.512	36.512	3.5	3.3		141.0	195.0	23.78	3800	5100
	82.000	22.225	17.000	21.976	21.976	21.976	21.976	3.5	0.5		61.2	84.3	10.28	4500	6000
	82.550	22.225	16.510	21.590	21.590	21.590	21.590	3.5	1.3		61.2	84.3	10.28	4500	6000
	85.000	17.462	13.495	17.462	17.462	17.462	17.462	3.5	1.5		49.7	65.5	7.99	4400	5900

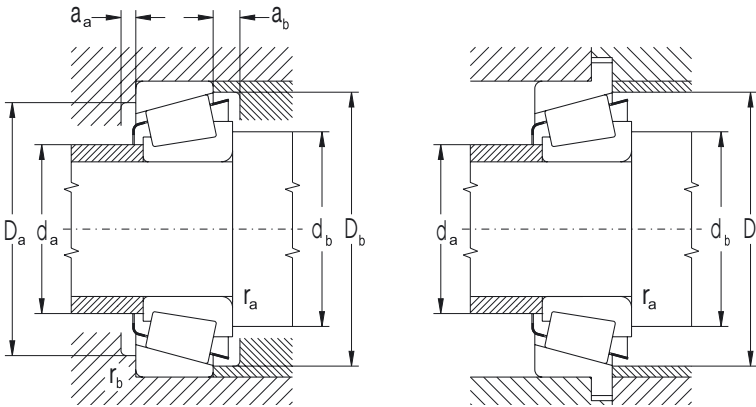

Bearing Designation Cone/ Cup	Abutment and Fillet Dimensions									Weight ~	Dimension Deviations						Factors		
	$d_a$	$d_b$	$D_a$	$D_b$	$D_b$	$a_a$	$a_b$	$r_a$	$r_b$		$\Delta d_{mp}$	$\Delta D_{mp}$	$\Delta T_s$						
	max	min	min	max	min	min	min	max	max		max	min	max	min	e	Y	$Y_0$		
	mm									kg	$\mu\text{m}$								
<b>LM300849</b> /300811	45.0	52.0	61.0		65.0	3.5	5.0	**	1.5	0.23	0	-13	0	-25	+203	0	0.35	1.72	1.20
<b>18590/18520</b>	46.0	53.0	66.0		69.0	4.0	5.5	3.5	1.5	0.27	+13	0	+25	0	+203	0	0.35	1.71	1.20
<b>LM501349</b> /501310	46.5	53.0	67.0		70.0	3.5	5.5	3.5	0.8	0.32	+13	0	+25	0	+203	0	0.40	1.50	
<b>LM501349</b> /501314	46.5	53.0	66.0		70.0	1.5	5.5	3.5	0.8	0.34	+13	0	+25	0	+203	0	0.40	1.50	1.00
<b>24780/24720</b>	47.0	54.0	68.0		72.0	3.5	5.5	3.5	0.8	0.41	+13	0	+25	0	+203	0	0.39	1.53	
<b>3585/3525</b>	48.0	50.0	75.0		81.0	3.5	6.5	1.5	3.3	0.82	+13	0	+25	0	+203	0	0.31	1.96	0.77
<b>HM803146</b> /803110	53.0	60.0	74.0		85.0	4.0	7.5	3.5	3.3	0.89	+13	0	+25	0	+203	0	0.55	1.10	1.08
<b>25577/25520</b>	49.0	55.0	74.0		77.0	4.5	5.5	3.5	0.8	0.58	+13	0	+25	0	+203	0	0.33	1.79	
<b>25577/25523</b>	51.0	58.0	72.0		77.0	1.0	5.5	3.5	2.3	0.58	+13	0	+25	0	+203	0	0.33	1.79	1.20
<b>25577/25521</b>	51.0	58.0	72.0		77.0	1.0	5.5	3.5	2.3	0.58	+13	0	+25	0	+203	0	0.33	1.79	
<b>HM807040</b> /807010	59.0	66.0	89.0		100.0	4.0	7.0	3.5	3.3	1.62	+13	0	+25	0	+203	0	0.49	1.23	0.70
<b>2580/25522</b>	50.0	57.0	73.0		77.0	4.5	5.5	3.5	2.0	0.56	+13	0	+25	0	+203	0	0.33	1.79	0.90
<b>HM803149</b> /803010	53.4	62.0	74.0		85.0	7.5	4.0	3.6	3.2	0.84	+13	0	+25	0	+203	0	0.55	1.10	0.74
<b>3782/3720</b>	52.0	58.0	82.0		88.0	3.5	7.0	3.5	3.3	0.95	+13	0	+25	0	+203	0	0.34	1.77	
<b>HM903249</b> /903210	54.0	65.0	81.0		91.0	2.0	7.0	3.5	0.8	1.00	+13	0	+25	0	+203	0	0.74	0.81	0.99
<b>U2497/U460L</b>																			0.74
<b>17887/17831</b>	51.0	56.0	71.0		74.0	3.5	5.0	2.0	1.3	0.40	+13	0	+25	0	+203	0	0.37	1.60	
<b>LM102949</b> /102910	50.0	56.0	68.0		70.0	3.0	4.5	3.5	0.8	0.31	+13	0	+25	0	+203	0	0.31	1.97	0.90
<b>LM603049</b> /603011	50.0	57.0	71.0		74.0	5.0	3.5	3.6	0.8	0.36	+13	0	+25	0	+203	0	0.43	1.41	
<b>LM603049</b> /603012	50.0	57.0	71.0		74.0	5.0	2.0	3.6	0.8	0.37	+13	0	+25	0	+203	0	0.43	1.41	
<b>25590/25523</b>	51.0	58.0	72.0		77.0	1.0	5.5	3.5	2.3	0.58	+13	0	+25	0	+203	0	0.33	1.79	
<b>LM503349</b> /503310	51.0	55.0	67.0		71.0	3.5	5.0	2.3	1.5	0.30	0	-13	0	-25	+203	0	0.40	1.49	
<b>18690/18620</b>	51.0	56.0	71.0		74.0	3.5	5.0	2.8	1.5	0.33	+13	0	+25	0	+203	0	0.37	1.60	
<b>JLM104948</b> /104910	55.0	60.0	76.0		78.0	4.0	5.5	3.0	0.5	0.41	0	-12	0	-18	+203	0	0.31	1.97	
<b>HM807046</b> /807010	63.0	70.0	89.0		100.0	4.0	7.0	3.5	3.3	1.49	+13	0	+25	0	+203	0	0.49	1.23	
<b>LM104949</b> /104910	55.0	62.0	76.0		78.0	5.5	4.5	3.5	0.5	0.42	+13	0	+25	0	+203	0	0.31	1.97	
<b>LM104949</b> /104911	55.0	62.0	75.0		78.0	4.5	5.5	3.5	1.3	0.42	+13	0	+25	0	+203	0	0.31	1.97	
<b>18790/18720</b>	56.0	62.0	77.0		80.0	3.5	5.0	3.5	1.5	0.36	+13	0	+25	0	+203	0	0.41	1.48	



# Single Row Tapered Roller Bearings in Inch Dimensions

d = 50.800 to 92.075 mm

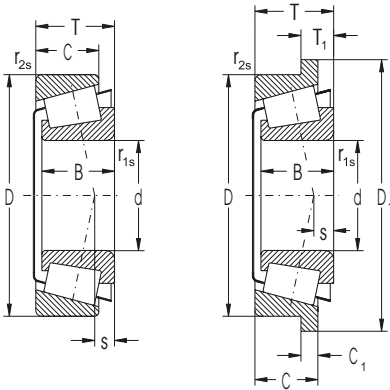

Dimensions											Basic Load Rating		Fatigue	Limiting Speed	
d	D	D <sub>1</sub>	B	C	C <sub>1</sub>	T	T <sub>1</sub>	r <sub>1s</sub>	r <sub>2s</sub>	s	C <sub>i</sub>	C <sub>cr</sub>	load limit	for Lubrication with	
											kN		kN	min <sup>-1</sup>	
mm															
50.800	88.900	22.225	16.513	20.638	3.5	1.3	74.3	87.3	10.65	4400	5800				
	90.000	22.225	15.875	20.000	3.5	2.0	74.3	87.3	10.65	4400	5800				
	92.075	25.400	19.845	24.608	3.5	0.8	84.8	119.0	14.51	4200	5600				
	93.264	30.302	23.812	30.162	3.5	3.3	103.0	137.0	16.71	4200	5500				
52.388	92.075	25.400	19.845	24.608	3.5	0.8	84.8	119.0	14.51	4200	5600				
	93.264	30.302	23.812	30.162	2.3	3.3	95.8	120.0	14.63	4600	6200				
55.000	90.000	23.000	18.500	23.000	1.5	0.5	81.4	115.0	14.02	4200	5500				
57.150	104.775	29.317	24.605	30.162	2.3	3.3	109.0	144.0	17.56	3700	4900				
	96.838	21.946	15.875	21.000	2.3	0.8	80.4	101.0	12.32	3900	5200				
	96.838	21.946	20.274	25.400	2.3	2.3	80.4	101.0	12.32	3900	5200				
	96.838	21.946	15.875	21.000	3.5	0.8	80.4	101.0	12.32	3900	5200				
	96.838	21.946	20.274	25.400	3.5	2.3	80.4	101.0	12.32	3900	5200				
	96.838	21.946	15.875	21.000	5.0	0.8	80.4	101.0	12.32	3900	5200				
	96.838	21.946	20.274	25.400	5.0	2.3	80.4	101.0	12.32	3900	5200				
	96.838	21.946	20.274	25.400	0.8	0.8	80.4	101.0	12.32	3900	5200				
	98.425	21.946	17.826	21.000	2.4	0.8	80.4	101.0	12.32	3900	5200				
98.425	21.946	17.826	21.000	3.5	0.8	80.4	101.0	12.32	3900	5200					
63.500	107.950	25.400	19.050	25.400	3.5	3.3	92.8	143.0	17.44	3400	4500				
	112.712	30.048	23.812	30.162	3.5	3.3	111.0	164.0	20.00	3400	4500				
66.675	110.000	21.996	18.824	22.000	0.8	1.3	86.4	116.0	14.15	3400	4500				
	112.712	30.048	23.812	30.162	3.5	3.3	111.0	164.0	20.00	3400	4500				
	112.712	30.048	23.812	30.162	5.5	3.3	111.0	164.0	20.00	3400	4500				
	122.238	38.354	29.718	38.100	3.5	3.3	191.0	249.0	30.37	3200	4300				
68.262	110.000	21.996	18.824	22.000	5.0	1.3	86.4	116.0	14.15	3400	4500				
69.850	117.475	30.162	23.812	30.162	3.5	3.3	118.0	179.0	21.83	3200	4200				
	120.000	30.162	23.444	29.794	3.5	0.8	118.0	179.0	21.83	3200	4200				
71.438	117.475	30.162	23.812	30.162	3.5	3.3	118.0	179.0	21.83	3200	4200				
73.025	112.712	25.400	19.050	25.400	3.5	3.3	97.0	155.0	18.90	3200	4300				
	117.475	30.162	23.812	30.162	3.5	3.3	118.0	179.0	21.83	3200	4200				
80.962	150.089	46.672	36.512	44.450	5.0	3.3	264.0	368.0	42.98	2500	3400				
82.550	125.412	25.400	19.845	25.400	3.5	1.5	101.0	162.0	19.53	2900	3800				
	133.350	33.338	26.195	33.338	3.5	3.3	154.0	245.0	29.20	2700	3700				
	139.992	36.098	28.575	36.512	3.5	3.3	175.0	262.0	30.94	2700	3600				
	146.050	41.275	31.750	41.275	3.5	3.3	208.0	301.0	35.26	2600	3400				
85.026	150.089	46.672	36.512	44.450	3.5	3.3	264.0	368.0	42.75	2500	3400				
89.974	146.975	40.000	32.500	40.000	7.0	3.5	206.0	310.0	35.93	2500	3300				
92.075	152.400	36.322	30.162	39.688	3.5	3.3	183.0	287.0	32.95	2400	3300				



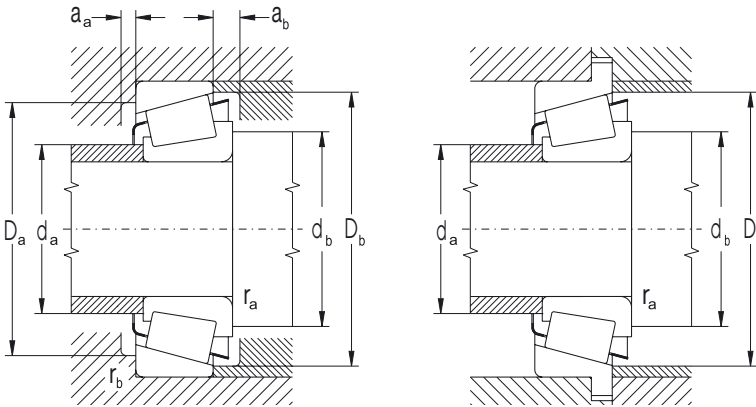

Bearing Designation Cone/ Cup	Abutment and Fillet Dimensions										Weight ~	Dimension Deviations						Factors		
	d <sub>a</sub>	d <sub>b</sub>	D <sub>a</sub>	D <sub>a</sub>	D <sub>b</sub>	a <sub>a</sub>	a <sub>b</sub>	r <sub>a</sub>	r <sub>b</sub>			Δdmp		ΔDmp		ΔTs		e	Y	Y <sub>0</sub>
	max	min	min	max	min	min	min	max	max			max	min	max	min	max	min			
	mm										kg	μm								
<b>368A/362A</b>	56.0	62.0	81.0		84.0	5.0	5.5	3.5	1.3	0.50	+13	0	+25	0	+203	0	0.32	1.88	1.20	
<b>368A/362X</b>	56.0	62.0	81.0		84.0	5.0	5.5	3.5	2.0	0.51	+13	0	+25	0	+203	0	0.32	1.88		
<b>28580/28521</b>	57.0	63.0	83.0		87.0	3.5	5.0	3.5	0.8	0.69	+13	0	+25	0	+203	0	0.38	1.59	1.20	
<b>3780/3720</b>	58.0	64.0	82.0		88.0	3.5	7.0	3.5	3.3	0.84	+13	0	+25	0	+203	0	0.34	1.77		
<b>28584/28521</b>	58.0	65.0	83.0		87.0	3.5	5.0	3.5	0.8	0.66	+13	0	+25	0	+203	0	0.38	1.59	1.00	
<b>3767/3720</b>	59.0	63.0	82.0		88.0	3.5	7.0	2.3	3.3	0.81	+13	0	+25	0	+203	0	0.34	1.77		
<b>JLM506849</b> <b>/506810</b>	61.0	63.0	82.0		86.0	3.5	5.0	1.5	0.5	0.55	0	-15	0	-18	+203	0	0.40	1.49	1.00	
<b>462/453X</b>	63.0	67.0	92.0		98.0	3.0	5.5	2.3	3.3	1.04	+13	0	+25	0	+203	0	0.34	1.79	0.77	
<b>387/382A</b>	62.0	66.0	89.0		92.0	5.5	6.0	2.3	0.8	0.58	+13	0	+25	0	+203	0	0.35	1.69		
<b>387/382S</b>	62.0	69.0	87.0		91.0	5.5	6.0	3.5	2.3	0.64	+13	0	+25	0	+203	0	0.35	1.69	1.08	
<b>387A/382A</b>	62.0	69.0	89.0		92.0	6.0	5.5	3.5	0.8	0.57	+13	0	+25	0	+203	0	0.35	1.69		
<b>387A/382S</b>	62.0	69.0	87.0		91.0	1.0	6.0	3.5	2.3	0.64	+13	0	+25	0	+203	0	0.35	1.69	1.20	
<b>387AS/382A</b>	62.0	72.0	89.0		92.0	5.5	6.0	5.0	0.8	0.56	+13	0	+25	0	+203	0	0.35	1.69		
<b>387AS/382S</b>	62.0	69.0	87.0		91.0	5.5	6.0	3.5	2.3	0.64	+13	0	+25	0	+203	0	0.35	1.69	0.70	
<b>387S/382S</b>	62.0	69.0	87.0		91.0	5.5	6.0	3.5	2.3	0.64	+13	0	+25	0	+203	0	0.35	1.69		
<b>387/382A</b>	62.0	66.0	89.0		92.0	6.0	5.0	2.4	0.8	0.61	+13	0	+25	0	+203	0	0.35	1.69	0.90	
<b>387A/382</b>	62.0	69.0	90.0		92.0	5.5	4.0	3.5	0.8	0.62	+13	0	+25	0	+203	0	0.35	1.69		
<b>29585/29520</b>	71.0	77.0	96.0		103.0	3.0	6.0	3.5	3.3	0.91	+13	0	+25	0	+203	0	0.46	1.31	0.74	
<b>3982/3920</b>	71.0	77.0	99.0		106.0	3.5	6.5	3.5	3.3	1.22	+13	0	+25	0	+203	0	0.40	1.49		
<b>395A/394A</b>	73.0	73.0	101.0		104.0	4.5	4.0	0.8	1.3	1.06	+13	0	+25	0	+203	0	0.40	1.49	0.99	
<b>3984/3920</b>	74.0	80.0	99.0		106.0	3.5	6.5	3.5	3.3	0.78	+13	0	+25	0	+203	0	0.40	1.49		
<b>3994/3920</b>	74.0	84.0	99.0		106.0	3.5	6.5	5.5	3.5	1.15	+13	0	+25	0	+203	0	0.40	1.49	0.74	
<b>HM212049</b> <b>/212011</b>	82.0	75.0	108.0		116.0	9.0	6.5	3.5	3.3	1.84	+13	0	+25	0	+203	0	0.34	1.78		
<b>399AS/394A</b>	74.0	83.0	101.0		104.0	4.5	4.0	5.0	1.3	0.72	+13	0	+25	0	+203	0	0.40	1.49	0.90	
<b>33275/33462</b>	77.0	84.0	104.0		112.0	3.5	6.5	3.5	3.3	1.25	+13	0	+25	0	+203	0	0.44	1.38		
<b>33275/33472</b>	77.0	84.0	104.0		112.0	3.5	6.5	3.5	3.3	1.25	+13	0	+25	0	+203	0	0.44	1.38		
<b>33281/33462</b>	79.0	85.0	104.0		112.0	3.5	6.5	3.5	3.3	1.18	+13	0	+25	0	+203	0	0.44	1.38		
<b>29685/29620</b>	80.0	86.0	101.0		109.0	3.5	6.0	3.5	3.3	0.88	+13	0	+25	0	+203	0	0.49	1.23		
<b>33287/33462</b>	80.0	87.0	104.0		112.0	3.5	6.5	3.5	3.3	1.17	+13	0	+25	0	+203	0	0.44	1.38		
<b>740/742</b>	91.0	101.0	134.0		142.0	7.0	9.5	5.0	3.3	3.39	+25	0	+25	0	+203	0	0.33	1.84		
<b>27687/27620</b>	89.0	96.0	115.0		120.0	4.0	6.5	3.5	1.5	1.04	+25	0	+25	0	+203	0	0.42	1.44		
<b>47686/47620</b>	90.0	97.0	119.0		128.0	5.0	7.5	3.5	3.3	1.69	+25	0	+25	0	+203	0	0.40	1.48		
<b>580/572</b>	91.0	98.0	125.0		133.0	4.0	7.0	3.5	3.3	2.14	+25	0	+25	0	+203	0	0.40	1.49		
<b>663/653</b>	92.0	99.0	131.0		139.0	5.0	8.0	3.5	3.3	2.75	+25	0	+25	0	+203	0	0.41	1.47		
<b>749/742</b>	95.0	101.0	134.0		142.0	7.0	9.5	3.5	3.3	3.21	+25	0	+25	0	+203	0	0.33	1.84		
<b>HM218248</b> <b>/218210</b>	99.0	112.0	133.0		141.0	5.5	9.0	7.0	3.5	2.36	0	-25	0	-25	+203	0	0.33	1.80		
<b>598/592A</b>	101.0	107.0	135.0		144.0	1.0	8.0	3.5	3.3	2.61	+25	0	+25	0	+203	0	0.44	1.36		





Weight	Factors				
	e	Y <sub>1</sub>	Y <sub>2</sub>	Y <sub>0</sub>	
kg					
23.6	0.45	1.5	2.2	1.5	
30.0	0.46	1.5	2.2	1.5	
40.5	0.45	1.5	2.2	1.5	
42.5	0.47	1.4	2.2	1.4	
51.5	0.44	1.5	2.3	1.5	
71.6	0.45	1.5	2.3	1.5	
76.3	0.48	1.4	2.1	1.4	
111.0	0.44	1.5	2.3	1.5	
117.0	0.47	1.4	2.1	1.4	
169.0	0.44	1.5	2.3	1.5	
177.0	0.47	1.4	2.2	1.4	
241.0	0.44	1.5	2.3	1.5	
113.0	0.43	1.6	2.3	1.5	
253.0	0.46	1.5	2.2	1.4	
263.0	0.48	1.4	2.1	1.4	
339.0	0.44	1.5	2.3	1.5	
351.0	0.46	1.5	2.2	1.4	
504.0	0.47	1.4	2.1	1.4	
713.0	0.45	1.5	2.2	1.5	
693.0	0.45	1.5	2.2	1.5	
1090.0	0.44	1.5	2.3	1.5	



# Thrust Ball Bearings



From the point of view of design, thrust ball bearings are divided into single direction and double direction.

Single direction thrust ball bearings consist of two washers with raceways and balls guided by a cage. Washers have flat seating surfaces, and that is why they must be supported so that all balls can be evenly loaded. Bearings carry the axial load only in one direction. They are not able to carry radial forces.

Double direction thrust ball bearings have two cages with balls between the central shaft washer and two housing washers with flat seating surfaces. The shaft washer has raceways on both sides and is fixed on the journal. Bearings are able to carry only axial forces in both directions.

## Boundary Dimensions

Boundary dimensions comply with the standard ISO 15 and are shown in the dimension tables of this publication.

## Designation

Bearing designation in standard design is in the dimension tables of this publication.

Difference from standard design is designated by additional symbols (section 2.2).

## Cage

Thrust ball bearings have in basic design cage a according to the table. Material and design designations are not indicated.

Customer's requiring special arrangements should be discuss this in advance with the supplier.

Bearings with Pressed Steel Cage	Bearings with Machined Brass or Steel Cage
51100 do 51144	51148 to 511/1000
51200 to 51236	51238 to 51260
51305 to 51324	51326 to 51330
51405 to 51418 <sup>1)</sup>	51420 to 51430
52202 to 52232	-
52305 to 52324	-
52405 to 52418 <sup>1)</sup>	52420

1) Bearings 51408 and 52408 are produced with solid cage made of polyamide with filling (TNGN)

## Tolerance

Bearings are commonly manufactured in tolerance class P0 which is not indicated. Bearings for more demanding arrangements are delivered in tolerance classes P6 and P5.

Limiting values of dimension and running accuracy are shown in Table 20.

## Misalignment

Bearings require keeping the tolerance for seating surfaces alignment, because misalignment causes increased stress at the contact of the balls with raceways. Therefore where alignment conditions cannot be kept, the use of thrust ball bearings is not recommended.

## Axial Equivalent Dynamic Load

$$P_a = F_a \quad [\text{kN}]$$

## Minimum Axial Load

At higher rotational speeds danger of ball sliding between ring raceways can occur because of centrifugal forces, if axial load  $F_a$  drops under minimum value. Minimum value  $F_{a \min}$  is calculated from equation:

$$F_{a \min} = M \left( \frac{n_{\max}}{1000} \right)^2 \quad [\text{kN}]$$

příčemž:

$F_{a \min}$	- minimum axial load	[kN]
$n_{\max}$	- maximum rotational speed	[min <sup>-1</sup> ]
M	- minimum axial load factor (values are in dimension tables)	

If the axial load is smaller than  $F_{a \min}$ , or if bearing relieving comes into being during operation, e.g. of one ball row in double direction bearing, or of one bearing when using a pair of single direction thrust bearings, it is necessary to secure minimum load, e.g. by means of springs.

## Axial Equivalent Static Load

$$P_{0a} = F_a \quad [\text{kN}]$$



# Single Direction Thrust Ball Bearings

d = 10 to 70 mm

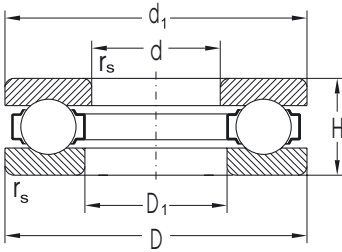

Dimensions						Basic Load Dynamic $C_a$	Rating Static $C_{oa}$	Fatigue load limit $P_u$	Limiting Speed for Lubrication with		Bearing Designation
d	D	$d_1$	$D_1$	H	$r_s$ min				Grease	Oil	
mm						kN	kN	min <sup>-1</sup>			
10	24	24	11	9	0,3	11,20	14,0	0,64	7900	10600	51100**
12	26	26	13	9	0,3	11,54	15,4	0,70	7500	10000	51101**
15	28	28	16	9	0,3	11,76	16,8	0,76	7100	9400	51102**
	32	13	17	12	0,6	17,27	24,4	1,11	6000	7900	51202**
17	30	30	18	9	0,3	12,66	19,6	0,89	7100	9400	51103**
	35	35	19	12	0,6	17,82	26,6	1,21	5600	7500	51203**
20	35	35	21	10	0,3	16,80	26,6	1,21	6300	8400	51104**
	40	40	22	14	0,6	24,53	37,7	1,71	5000	6700	51204**
25	42	42	26	11	0,6	20,27	35,5	1,61	5300	7100	51105**
	47	47	27	15	0,6	30,58	50,5	2,30	4500	6000	51205**
	52	52	27	18	1,0	38,91	61,5	2,80	3800	5000	51305**
30	60	60	27	24	1,0	60,50	89,4	4,06	3200	4200	51405**
	47	47	32	11	0,6	21,06	39,9	1,81	5000	6700	51106**
	52	52	32	16	0,6	30,28	58,2	2,65	4000	5300	51206**
	60	60	32	21	1,0	44,84	78,7	3,58	3300	4500	51306**
35	70	70	32	28	1,0	79,24	126,0	5,73	2700	3500	51406**
	52	52	37	12	0,6	22,51	46,6	2,12	4700	6300	51107**
	62	62	37	18	1,0	41,84	78,2	3,55	3500	4700	51207**
	68	68	37	24	1,0	58,83	105,0	4,77	2800	3800	51307**
40	80	80	37	32	1,1	94,72	155,0	7,05	2200	3000	51407**
	60	60	42	13	0,6	30,13	62,9	2,86	4200	5600	51108**
	68	68	42	19	1,0	48,40	92,4	4,20	3200	4200	51208**
	78	78	42	26	1,0	73,46	135,0	6,14	2700	3500	51308**
45	90	90	42	36	1,1	122,08	205,0	9,32	2000	2700	51408TNGN**
	65	65	47	14	0,6	31,25	69,2	3,15	4000	5300	51109**
	73	73	47	20	1,0	46,97	105,0	4,77	3000	4000	51209**
	85	85	47	28	1,0	87,20	164,0	7,45	2400	3200	51309**
50	100	100	47	39	1,1	141,70	243,0	11,05	1900	2500	51409**
	70	70	52	14	0,6	32,26	75,5	3,43	3800	5000	51110**
	78	78	52	22	1,0	51,92	111,0	5,05	2800	3800	51210**
55	78	78	57	16	0,6	36,54	93,2	4,24	3300	4500	51111**
	90	90	57	25	1,0	73,56	159,0	7,23	2500	3300	51211**
	105	105	57	35	1,1	122,57	246,0	11,18	1900	2500	51311**
	120	120	57	48	1,5	214,24	397,0	18,05	1600	2100	51411**
60	85	85	62	17	1,0	46,37	113,0	5,14	3200	4200	51112**
	110	110	62	35	1,1	125,24	270,0	12,27	1900	2500	51312**
	90	90	67	18	1,0	44,62	117,0	5,32	2300	3400	51113**
65	100	100	67	27	1,0	76,40	189,0	8,59	2400	3200	51213**
	115	115	67	36	1,1	129,28	287,0	13,05	1800	2400	51313**
	95	95	72	18	1,0	46,55	127,0	5,77	2800	3800	51114**
70	105	105	72	27	1,0	76,86	199,0	9,05	2200	3000	51214**
	125	125	72	40	1,1	158,36	340,0	15,45	1700	2200	51314**
	150	150	73	60	2,0	272,50	553,0	23,97	1200	1600	51414**

\*\* Bearings in the new standard NEW FORCE (see the catalogue NEW FORCE)

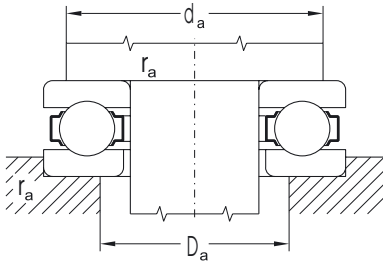

Abutment and Fillet Dimensions				Weight	Minimum Axial Load Factor
d	d <sub>a min</sub>	D <sub>a max</sub>	r <sub>a max</sub>	~	
mm				kg	
10	19	15	0,3	0,020	0,001
12	21	17	0,3	0,020	0,002
15	23	20	0,3	0,020	0,002
	25	22	0,6	0,050	0,004
17	25	22	0,3	0,030	0,003
	28	24	0,6	0,050	0,004
20	29	26	0,3	0,040	0,004
	32	28	0,6	0,080	0,008
25	35	32	0,6	0,060	0,006
	38	34	0,6	0,120	0,015
	41	36	1,0	0,180	0,020
	46	39	1,0	0,340	0,035
30	40	37	0,6	0,070	0,008
	43	39	0,6	0,140	0,018
	48	42	1,0	0,270	0,030
	54	46	1,0	0,530	0,085
35	45	42	0,6	0,080	0,012
	51	46	1,0	0,220	0,032
	55	48	1,0	0,390	0,050
	62	53	1,0	0,790	0,120
40	52	48	0,6	0,120	0,018
	57	51	1,0	0,270	0,047
	63	55	1,0	0,550	0,095
	70	60	1,0	1,140	0,190
45	57	53	0,6	0,150	0,025
	62	56	1,0	0,320	0,060
	69	61	1,0	0,690	0,130
	78	67	1,0	1,470	0,350
50	62	58	0,6	0,160	0,035
	67	61	1,0	0,390	0,082
55	69	64	0,6	0,240	0,040
	76	69	1,0	0,610	0,110
	85	75	1,0	1,340	0,270
	94	81	1,5	2,640	0,650
60	75	70	1,0	0,290	0,066
	90	80	1,0	1,430	0,350
65	80	75	1,0	0,330	0,086
	86	79	1,0	0,770	0,170
	95	85	1,0	1,570	0,450
70	85	80	1,0	0,360	0,110
	91	84	1,0	0,810	0,210
	103	92	1,0	2,060	0,540
	118	102	2,0	5,480	1,600

# Single Direction Thrust Ball Bearings

d = 75 to 150 mm

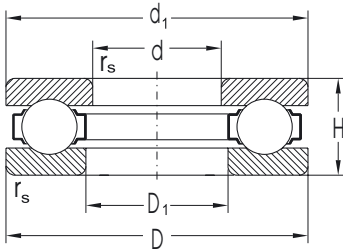

Dimensions						Basic Load Dynamic $C_a$	Rating Static $C_{oa}$	Fatigue load limit $P_u$	Limiting Speed for Lubrication with		Bearing Designation
d	D	$d_1$	$D_1$	H	$r_s$ min				Grease	Oil	
mm						kN		kN	min <sup>-1</sup>		
75	100	100	77	19	1,0	49,84	136,0	6,18	2700	3500	<b>51115**</b>
	110	110	77	27	1,0	81,17	209,0	9,50	2200	3000	<b>51215**</b>
	135	135	77	44	1,5	193,20	426,0	18,90	1600	2100	<b>51315**</b>
80	105	105	82	19	1,0	49,95	141,0	6,41	2700	3500	<b>51116**</b>
	115	115	82	28	1,0	86,35	219,0	9,95	2000	2700	<b>51216**</b>
	170	170	83	68	2,1	326,51	751,0	30,53	890	1200	<b>51416**</b>
85	110	110	87	19	1,0	51,52	150,0	6,82	2700	3500	<b>51117**</b>
	125	125	88	31	1,0	104,94	264,0	11,71	2000	2700	<b>51217**</b>
	150	150	88	49	1,5	227,46	517,0	21,68	1300	1800	<b>51317**</b>
90	120	120	92	22	1,0	66,86	190,0	8,43	2000	2700	<b>51118**</b>
	155	155	93	50	1,5	236,64	556,0	22,83	1100	1500	<b>51318**</b>
	190	187	93	77	2,1	384,81	970,0	37,26	790	1060	<b>51418**</b>
100	135	135	102	25	1,0	95,31	268,0	11,24	2000	2700	<b>51120**</b>
	170	170	103	55	1,5	266,06	628,0	24,57	1060	1400	<b>51320**</b>
	210	205	103	85	3,0	453,49	1220,0	44,54	750	1000	<b>51420**</b>
110	145	145	112	25	1,0	97,78	288,0	11,59	1900	2500	<b>51122**</b>
	190	187	113	63	2,0	323,30	807,0	29,95	890	1200	<b>51322**</b>
	230	225	113	95	3,0	495,91	1400,0	48,81	670	890	<b>51422**</b>
120	155	155	122	25	1,0	95,12	308,0	11,94	1600	2100	<b>51124**</b>
	210	205	123	70	2,1	368,88	977,0	34,57	790	1060	<b>51324**</b>
	250	245	123	102	4,0	566,04	1590,0	53,14	630	840	<b>51424**</b>
130	170	170	132	30	1,0	127,33	406,0	15,07	1400	1900	<b>51126**</b>
	225	220	134	75	2,1	389,02	1070,0	36,51	750	1000	<b>51326**</b>
	270	265	134	110	4,0	643,37	2010,0	64,60	560	750	<b>51426**</b>
140	240	235	144	80	2,1	438,84	1260,0	41,55	710	940	<b>51328**</b>
150	190	188	152	31	1,0	131,61	448,0	15,62	1300	1800	<b>51130**</b>
	215	212	153	50	1,5	281,84	835,0	28,10	900	1300	<b>51230**</b>
	250	245	154	80	2,1	454,74	1360,0	43,71	670	900	<b>51330**</b>

\*\* Bearings in the new standard NEW FORCE (see the catalogue NEW FORCE)



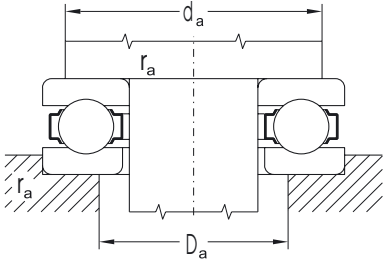

Abutment and Fillet Dimensions				Weight ~	Minimum Axial Load Factor
d	d <sub>a min</sub>	D <sub>a max</sub>	r <sub>a max</sub>		
mm				kg	
75	90	85	1,0	0,420	0,120
	96	89	1,0	0,860	0,270
	111	99	1,5	2,680	0,760
80	95	90	1,0	0,430	0,150
	101	94	1,0	0,950	0,350
	133	117	2,0	7,970	2,700
85	100	95	1,0	0,460	0,180
	109	101	1,0	1,290	0,430
	123	111	1,5	3,660	1,200
90	108	102	1,0	0,680	0,260
	129	116	1,5	3,880	1,500
	149	131	2,0	11,200	4,100
100	121	114	1,0	0,990	0,340
	142	128	1,5	5,110	2,000
	165	145	2,5	15,000	6,200
110	131	124	1,0	1,080	0,420
	158	142	2,0	7,870	2,800
	181	159	2,5	20,200	9,000
120	141	134	1,0	1,160	0,530
	173	157	2,0	10,900	4,100
	197	173	3,0	25,500	13,000
130	154	146	1,0	1,870	0,650
	186	169	2,0	13,300	6,200
	213	187	3,0	32,000	18,000
140	199	181	2,0	15,900	8,000
150	174	166	1,0	2,200	0,950
	189	176	1,5	6,100	2,800
	209	191	2,0	16,500	10,000

# Single Direction Thrust Ball Bearings

d = 160 to 240 mm

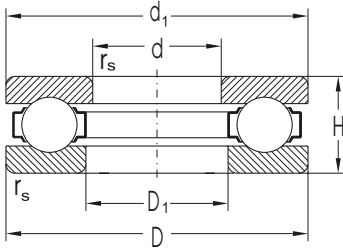

Dimensions						Basic Load Dynamic $C_a$	Rating Static $C_{oa}$	Fatigue load limit $P_u$	Limiting Speed for Lubrication with		Bearing Designation
d	D	$d_1$	$D_1$	H	$r_s$ min				Grease	Oil	
mm						kN		kN	min <sup>-1</sup>		
160	200	198	162	31	1,0	133,75	476,0	16,13	1300	1800	<b>51132**</b>
	225	222	163	51	1,5	288,75	874,0	28,63	890	1200	<b>51232**</b>
170	215	213	172	34	1,1	160,14	582,0	19,07	1200	1600	<b>51134**</b>
	240	237	173	55	1,5	300,67	897,0	28,48	840	1100	<b>51234**</b>
180	225	222	185	34	1,1	165,64	639,0	20,41	1100	1500	<b>51136**</b>
	250	247	183	56	1,5	325,28	1030,0	31,93	840	1100	<b>51236**</b>
190	240	237	193	37	1,1	200,09	715,0	22,16	1060	1400	<b>51138**</b>
	270	267	194	62	2,0	381,99	1240,0	37,17	750	1000	<b>51238**</b>
200	250	247	203	37	1,1	197,40	738,0	22,36	1060	1400	<b>51140**</b>
	280	277	204	62	2,0	376,64	1240,0	36,38	750	1000	<b>51240**</b>
220	270	267	223	37	1,1	200,09	760,0	22,07	1000	1300	<b>51144**</b>
240	300	297	243	45	1,5	277,13	1040,0	28,77	840	1100	<b>51148**</b>

\*\* Bearings in the new standard NEW FORCE (see the catalogue NEW FORCE)



# Double Direction Thrust Ball Bearings

$d_2 = 10$  to  $140$  mm

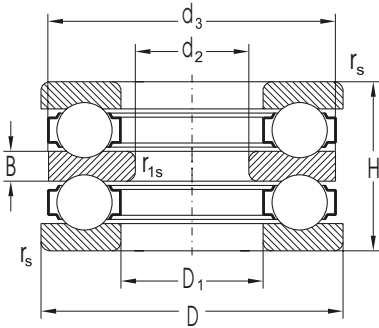

Dimensions								Basic Load Dynamic $C_a$	Rating Static $C_{oa}$	Fatigue load limit $P_u$	Limiting Speed for Lubrication with		
$d_2$	$D$	$d_3$	$D_1$	H	B	$r_{s \text{ min}}$	$r_{1s \text{ min}}$				Grease	Oil	
mm								kN		kN	min <sup>-1</sup>		
10		32	32,0	17	22	5	0,6	0,3	17,27	24,4	1,11	6000	7900
15		40	40,0	22	26	6	0,6	0,3	24,53	37,7	1,71	5000	6700
		60	60,0	27	45	11	1,0	0,6	60,50	89,4	4,06	3200	4200
20		47	47,0	27	28	7	0,6	0,3	30,58	50,5	2,30	4500	6000
		52	52,0	27	34	8	1,0	0,3	38,91	61,5	2,80	3800	5000
		70	70,0	32	52	12	1,0	0,6	79,24	126,0	5,73	2700	3500
25		52	52,0	32	29	7	0,6	0,3	30,28	58,2	2,65	4000	5300
		60	60,0	32	38	9	1,0	0,3	44,84	78,7	3,58	3300	4500
		80	80,0	37	59	14	1,1	0,6	94,72	155,0	7,05	2200	3000
30		62	62,0	37	34	8	1,0	0,3	41,45	78,2	3,55	3500	4700
		68	68,0	37	44	10	1,0	0,3	60,50	105,0	4,77	2800	3800
		68	68,0	42	36	9	1,0	0,6	48,40	92,4	4,20	3200	4200
		78	78,0	42	49	12	1,0	0,6	74,15	135,0	6,14	2700	3500
		90	90,0	42	65	15	1,1	0,6	122,08	205,0	9,32	2 000	2700
35		73	73,0	47	37	9	1,0	0,6	46,97	105,0	4,77	3000	4000
		85	85,0	47	52	12	1,0	0,6	87,20	164,0	7,45	2400	3200
		100	100,0	47	72	17	1,1	0,6	141,70	243,0	11,05	1900	2500
40		78	78,0	52	39	9	1,0	0,6	51,92	111,0	5,05	2800	3800
45		90	90,0	57	45	10	1,0	0,6	73,56	159,0	7,23	2500	3300
		105	105,0	57	64	15	1,1	0,6	123,76	246,0	11,18	1900	2500
		120	120,0	57	87	20	1,5	0,6	212,18	397,0	18,05	1600	2100
50		110	110,0	62	64	15	1,1	0,6	125,24	270,0	12,27	1900	2500
55		100	100,0	67	47	10	1,0	0,6	76,40	189,0	8,59	2400	3200
		115	115,0	67	65	15	1,1	0,6	129,28	287,0	13,05	1800	2400
		105	105,0	72	47	10	1,0	1,0	77,62	198,0	9,00	2200	3000
		125	125,0	72	72	16	1,1	1,0	161,32	340,0	15,45	1700	2200
		150	150,0	73	107	24	2,0	1,0	272,50	553,0	24,83	1200	1600
60		110	110,0	77	47	10	1,0	1,0	76,62	209,0	9,50	2200	3000
		135	135,0	77	79	18	1,5	1,0	193,20	426,0	19,36	1600	2100
		170	170,0	83	120	27	2,1	1,0	336,02	751,0	31,49	890	1200
65		115	115,0	82	48	10	1,0	1,0	86,35	219,0	9,95	2000	2700
		170	170,0	83	120	27	2,1	1,0	336,02	751,0	31,49	890	1200
		190	189,5	93	135	30	2,1	1,1	403,86	970,0	38,67	790	1060
70		125	125,0	88	55	12	1,0	1,0	104,94	264,0	12,00	1900	2500
		150	150,0	88	87	19	1,5	1,0	243,07	517,0	22,41	1300	1800
		190	189,5	93	135	30	2,1	1,1	403,86	970,0	38,67	790	1060
75		155	155,0	93	88	19	1,5	1,0	245,92	556,0	23,57	1100	1500
100		210	209,5	123	123	27	2,1	1,1	368,88	977,0	35,67	790	1060
140		225	224,5	163	90	20	1,5	1,1	294,25	874,0	29,41	890	1200

\*\* Bearings in the new standard NEW FORCE (see the catalogue NEW FORCE)

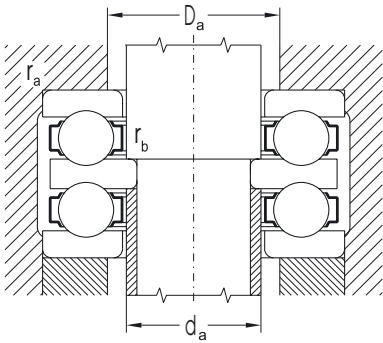

Bearing Designation	Abutment and Fillet Dimensions					Weight ~ kg	Minimum Axial Load Factor
	$d_2$	$d_{a \max}$	$D_{a \max}$	$r_{a \max}$	$r_{b \max}$		
	mm						
<b>52202**</b>	10	15	22	0,6	0,3	0,08	0,004
<b>52204**</b>	15	20	28	0,6	0,3	0,15	0,008
<b>52405**</b>		25	39	1,0	0,6	0,63	0,035
<b>52205**</b>	20	25	34	0,6	0,3	0,23	0,015
<b>52305**</b>		25	36	1,0	0,3	0,33	0,020
<b>52406**</b>		30	46	1,0	0,6	1,00	0,085
<b>52206**</b>	25	30	39	0,6	0,3	0,27	0,018
<b>52306**</b>		30	42	1,0	3,0	0,49	0,030
<b>52407**</b>		35	53	1,0	0,6	1,44	0,120
<b>52207**</b>	30	35	46	1,0	0,3	0,42	0,032
<b>52307**</b>		35	48	1,0	0,3	0,71	0,050
<b>52208**</b>		40	51	1,0	0,6	0,54	0,047
<b>52308**</b>		40	55	1,0	0,6	1,06	0,095
<b>52408TNGN**</b>		40	60	1,0	0,6	2,03	0,190
<b>52209**</b>	35	45	56	1,0	0,6	0,62	0,060
<b>52309**</b>		45	61	1,0	0,6	1,29	0,130
<b>52409**</b>		45	67	1,0	0,6	2,71	0,350
<b>52210**</b>	40	50	61	1,0	0,6	0,71	0,082
<b>52211**</b>	45	55	69	1,0	0,6	1,12	0,110
<b>52311**</b>		55	75	1,0	0,6	2,51	0,270
<b>52411**</b>		55	81	1,5	0,6	4,70	0,650
<b>52312**</b>	50	60	80	1,0	0,6	2,68	0,350
<b>52213**</b>	55	65	79	1,0	0,6	1,36	0,170
<b>52313**</b>		65	85	1,0	0,6	2,90	0,450
<b>52214**</b>		70	84	1,0	0,6	1,48	0,210
<b>52314**</b>		70	92	1,0	1,0	3,90	0,540
<b>52414**</b>		70	102	2,0	1,0	9,71	1,600
<b>52215**</b>	60	75	89	1,0	1,0	1,57	0,270
<b>52315**</b>		75	99	1,5	1,0	4,83	0,760
<b>52216**</b>	65	80	95	1,0	1,0	1,69	0,350
<b>52416**</b>		80	117	2,0	1,0	14,00	2,700
<b>52217**</b>	70	85	101	1,0	1,0	2,34	0,430
<b>52317**</b>		85	111	1,5	1,0	6,43	1,200
<b>52418**</b>		90	131	2,0	1,0	19,60	4,100
<b>52318**</b>	75	90	116	1,5	1,0	6,60	1,500
<b>52324**</b>	100	120	157	2,0	1,0	17,20	4,100
<b>52232**</b>	140	160	186	1,5	1,0	12,20	3,200

# Spherical Roller Thrust Bearing

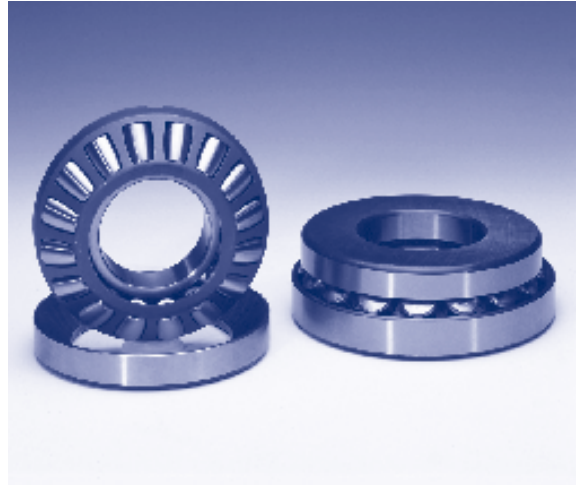

Spherical roller thrust bearings have a great number of asymmetrical spherical rollers with a good conformity to the raceway of the shaft and housing washers and that is why they are suitable for accommodating great axial load as well as certain radial load at relatively high rotational speed. Bearings are separable which can be utilized when mounting.

The internal bearing design requires oil lubrication. An exception is created by conditions where the bearing is working at very small rotational speed.

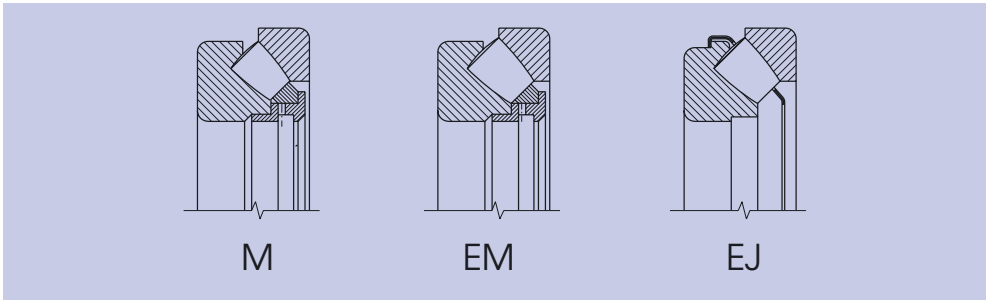

## Boundary Dimensions

Boundary dimensions of spherical roller thrust bearings comply with the standard ISO 104 and are shown in dimension tables.

## Designation

Bearing designation of standard bearings is in the dimension tables of this publication.

Difference from basic design is indicated by additional symbols shown in section 2.2 .

## Cage

Spherical roller thrust bearings in “M” design have brass cages guided by a steel sleeve on the shaft washer.

Bearings in “J” design have pressed steel cages guided on the shaft washer.

Bearings in “J” design are interchangeable with bearings with machined brass cage. If the bearing with machined brass cage is to be replaced in arrangement, where the shaft washer rests on the shaft on the face of steel sleeve which guides the cage by the bearing in “J” design, it is necessary to insert a spacer between the shaft washer and original shaft shoulder, as shown in the picture.

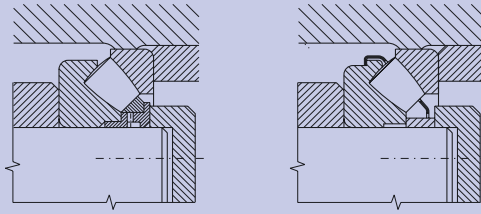

## Tolerance

Bearings are commonly produced in normal tolerance class P0 which is not indicated. Limiting values of dimension and running deviations are shown in table 20.

## Misalignment

Spherical raceway of the bearing housing washer enables, at common operation conditions ( $P_a \leq 0.1C_a$ ) misalignment from the central position without damaging the correct bearing function of values according to the table below.

Bearing Type	Permissible Misalignment
292	2°
293	2°30'
294	3°

## Arrangement Design

Abutment and fillet dimensions shown in the dimension tables of this publication are suitable for bearings where the load  $P_a \leq 0.1C_a$ . At higher load it is suitable to support bearing washers along the face surface, i.e.  $d_a = d_1$  and  $D_a = D_1$ .

## Assembly

To ensure proper function of bearing in arrangement its assembly in the position with the vertical axis of rotation is appropriate. In case that it is not possible to comply with this principle, we recommend consulting with TKS.

## Axial Equivalent Dynamic Load

$$P_a = F_a + 1.2F_r \quad (F_r \leq 0.55F_a) \quad [\text{kN}]$$

## Minimum Axial Load

At higher rotational speed by spherical roller thrust bearings arises the danger of rolling element sliding. A potential problem exist in the use of spherical roller thrust bearings at higher rotational speed. the danger arises from the possibility of the rolling element sliding between raceways due to centrifugal forces acting in such cases when the axial load  $F_a$  drops under minimum value. For calculation of minimum value  $F_{a \min}$  following relation is used:

$$\frac{C_{oa}}{2000} \leq F_{a \min} = 1,8 F_r + M \cdot \left( \frac{n_{\max}}{1000} \right)^2 \quad [\text{kN}]$$

- $F_{a \min}$  – minimum axial load [kN]
- $F_r$  – radial bearing load [kN]
- $C_{oa}$  – axial basic static load rating [kN]  
(values are in dimension tables)
- $n_{\max}$  – maximum rotational speed [min<sup>-1</sup>]
- $M$  – minimum axial load factor  
(values are in dimension tables)



If the external axial bearing load is too small, or if the bearing is relieved in operation, e.g. in a bearing pair, it is necessary to create axial load, e.g. with springs. If also radial load acts simultaneously, following condition must be fulfilled:

$$F_r \leq 0.55F_a$$

### Axial Equivalent Static Load

$$P_{oa} = F_a + 2.7F_r \quad (F_r \leq 0.55F_a) \quad [\text{kN}]$$

Static safety factor for spherical roller thrust bearings must be  $s_0 \geq 4$ .





# Spherical Roller Thrust Bearings

d = 50 to 160 mm

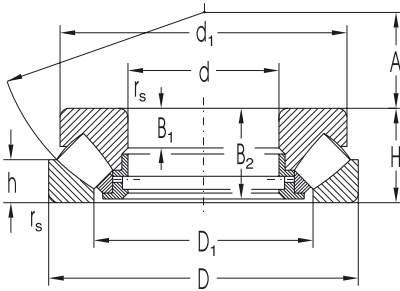

M, EM

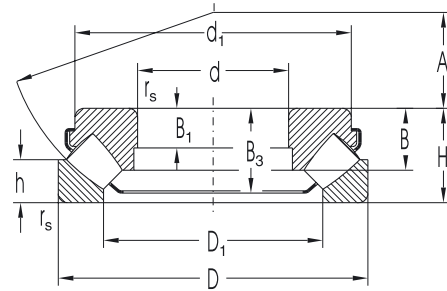

EJ

Dimensions												Basic Load Dynamic $C_a$	Rating Static $C_{oa}$	Fatigue load limit $P_u$
d	D	H	$d_1$	$D_1$	B	$B_1$	$B_2$	$B_3$	h	A	$r_{s \min}$			
mm												kN		kN
50	110	36	95,0	70,0	25,0	13		32,0	20,5	32	1,5	290	930	113,41
60	130	42	118,0	88,0	28,0	15	39,5	35,5	20,0	38	1,5	287	809	98,66
	130	42	118,0	87,0	27,0	27		37,0	20,0	38	1,2	382	1004	122,44
65	140	45	128,0	96,5	28,0	16	42,5	38,0	21,0	42	2,0	340	973	117,78
	140	45	128,0	93,0	29,5	16		39,0	21,0	42	2,0	434	1155	139,81
70	150	48	137,0	102,0	32,0	17	45,5		23,0	44	2,0	371	1070	126,81
	150	48	131,6	105,0	31,0	17		43,5	23,0	44	2,0	440	1280	150,28
75	160	51	146,0	109,0	34,5	18	48,0		24,0	47	2,0	429	1250	145,24
	160	51	146,0	108,0	33,5	18		47,0	24,0	47	2,0	524	1465	170,22
80	170	54	155,0	116,0	36,0	19	51,0		24,0	50	2,1	464	1370	156,25
	170	54	155,0	116,0	36,0	19		46,5	24,0	50	2,1	570	1430	163,10
85	180	58	164,0	125,0	38,0	21	55,0		28,0	54	2,1	527	1570	175,96
	180	58	164,0	123,0	37,0	21		50,0	28,0	54	2,0	692	1945	217,99
90	190	60	174,0	130,0		22	57,0		29,0	56	2,1	578	1780	196,23
	190	60	174,0	130,0		22	57,0		29,0	56	2,1	703	2172	239,45
100	170	42	150,0	128,0	26,2	15		37,3	20,5	58	1,5	436	1400	156,03
	210	67	193,0	144,5		24	64,0		32,0	62	3,0	705	2170	232,03
	210	67	193,0	144,0		24	64,0		32,0	62	2,5	865	2578	275,66
110	190	48	176,0	143,0		16	45,5		23,0	64	2,0	442	1420	153,34
	190	48	176,0	143,0	31,0	16		42,0	23,0	64	2,0	570	1760	190,05
	230	73	212,0	160,0		26	69,0		35,0	69	3,0	817	2600	270,41
	230	73	209,5	159,0		27			35,0	69	2,5	1022	3078	320,13
120	210	54	187,1	155,5	35,5	19		47,0	27,0	70	2,1	680	2500	262,35
	210	54	194,0	157,5		18	51,0		26,0	70	2,1	560	1830	192,04
	250	78	229,0	172,0		29	74,0		37,0	74	4,0	934	3000	304,20
	250	78	226,8	173,0		29			37,0	74	4,0	1180	3590	364,02
130	225	58	205,0	170,0	37,0	19	55,0		28,0	76	2,1	628	2070	212,52
	225	58	201,5	165,7		21		49,6	30,1	76	2,1	765	2950	302,86
	270	85	247,0	188,0	55,5	31	81,0		41,0	81	4,0	1090	3540	350,66
	270	85	245,0	188,0		31		74,0	41,0	81	4,0	1395	4300	425,94
140	240	60	219,0	183,0		20	57,0		29,0	82	2,1	675	2310	232,37
	240	60	214,9	178,9	38,5	22	-	52,4	30,0	82	2,1	850	3150	316,86
	280	85	257,0	197,5		31	81,0		41,0	86	4,0	1130	3750	366,06
	280	85	254,0	196,5	54,0	32		74,0	41,0	86	4,0	1509	4686	457,43
150	250	60	229,0	193,0		20	57,0		29,0	87	2,1	697	2430	240,70
	250	60	222,5	189,6	38,0	22	-	53,8	28,0	87	2,1	863	3236	320,54
	300	90	276,0	211,5		32	86,0		44,0	92	4,0	1280	4270	408,28
	300	90	273,0	209,5	58,0	34		79,0	44,0	92	4,0	1626	5241	501,12
160	270	67	243,6	202,3	42,0	24	-	58,6	33,0	92	3,0	1036	3977	385,49
	270	67	248,0	207,0		23	64,0		32,0	92	3,0	807	2810	272,37
	320	95	282,8	221,7	60,5	35	-	82,0	45,5	99	5,0	1800	6550	614,28

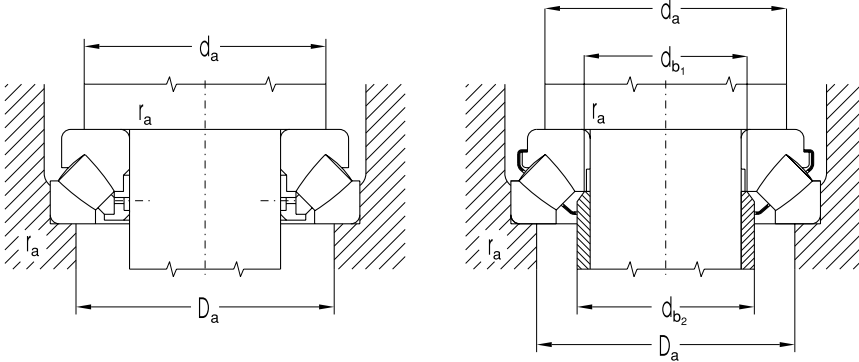

Limiting Speed for Lubrication with Oil	Bearing Designation	Abutment and Fillet Dimensions						Weight	Minimum Axial Load Factor
		d	$d_{a \min}$	$d_{b1 \max}$	$D_{a \max}$	$d_{b2 \min}$	$r_{a \max}$		
min <sup>-1</sup>		mm						kg	M
3100	<b>29410EJ</b>	50	70	55,8	90	59,5	1,50	1,67	0,110
2400	<b>29412M*</b>	60	90		109		1,50	2,60	0,082
2600	<b>29412EJ</b>		90	67,0	117	67,0	1,50	2,47	0,130
2200	<b>29413M*</b>	65	100		118		2,00	3,30	0,120
2400	<b>29413EJ</b>		100	72,0	118	72,0	2,00	3,26	0,140
2000	<b>29414M*</b>	70	105		126		2,00	4,00	0,140
2200	<b>29414EJ</b>		105	77,5	126	77,5	2,00	3,98	0,160
2000	<b>29415M*</b>	75	115		134		2,00	4,90	0,200
2200	<b>29415EJ</b>		115	82,5	134	82,5	2,00	4,90	0,180
1900	<b>29416M*</b>	80	120		141		2,00	5,80	0,230
2000	<b>29416EJ</b>		120	88,0	141	88,0	2,00	5,80	0,260
1800	<b>29417M*</b>	85	130		153		2,00	6,90	0,310
1800	<b>29417EJ</b>		130	94,0	153	94,0	2,00	6,67	0,240
1700	<b>29418M*</b>	90	135		161		2,00	8,10	0,400
1800	<b>29418EJ</b>		135	99,0	161	99,0	2,00	8,10	0,400
2000	<b>29320EJ</b>	100	130	107,0	147	107,0	1,50	3,95	0,580
1500	<b>29420M*</b>		150		178		2,50	11,80	0,590
1600	<b>29420EJ</b>		150	110,0	175	110,0	3,00	10,80	0,590
1600	<b>29322M*</b>	110	145		165		2,00	5,50	0,250
1600	<b>29322EJ</b>		145	117,0	165	117,0	2,00	5,40	0,390
1400	<b>29422M*</b>		165		196		2,50	14,50	0,850
1400	<b>29422EJ</b>		165	120,5	193	129,0	2,50	13,50	0,850
1600	<b>29324EJ</b>		160	128,0	181	128,0	2,00	7,41	0,780
1400	<b>29324M*</b>	120	160		184		2,00	7,60	0,420
1300	<b>29424M*</b>		180		212		3,00	18,10	0,910
1300	<b>29424EJ</b>		180	132,0	209	140,0	3,00	17,50	0,910
1300	<b>29326M</b>	130	170		198		2,00	9,30	0,540
1500	<b>29326EJ</b>		175	138,0	194	143,0	2,00	9,08	1,100
1200	<b>29426M*</b>		195		229		3,00	22,50	1,600
1200	<b>29426EJ</b>		195	142,5	227	153,0	3,00	21,60	1,600
1300	<b>29328M</b>	140	185		211		2,00	11,00	0,670
1400	<b>29328EJ</b>		185	148,0	208	154,0	2,00	10,50	1,200
1200	<b>29428M</b>		205		239		3,00	24,20	1,800
1200	<b>29428EJ</b>		205	153,0	239	162,0	3,00	23,00	1,800
1200	<b>29330M</b>	150	195		222		2,00	11,50	0,740
1400	<b>29330EJ</b>		195	158,0	219	163,0	2,00	10,90	1,300
1100	<b>29430M</b>		220		257		3,00	29,40	2,300
1100	<b>29430EJ</b>		220	163,0	275	175,0	3,00	28,20	2,300
1200	<b>29332EJ</b>		210	169,0	235	176,0	2,50	14,40	2,000
1100	<b>29332M</b>	160	210		239		2,50	15,20	0,990
1000	<b>29432EJ</b>		235	175,0	270	179,0	4,00	33,30	5,400

Deliveries of bearings marked with \* must be agreed with the producer.

# Spherical Roller Thrust Bearings

d = 160 to 320 mm

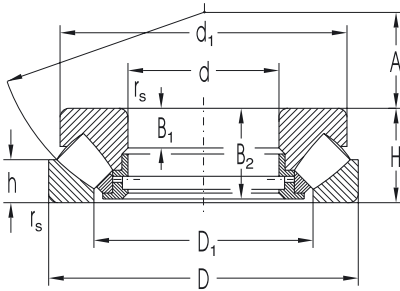

M, EM

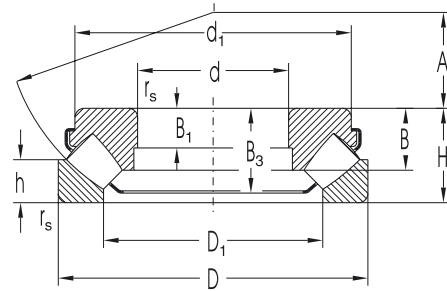

EJ

Dimensions											Basic Load Dynamic $C_a$	Rating Static $C_{oa}$	Fatigue load limit $P_u$	
d	D	H	$d_1$	$D_1$	B	$B_1$	$B_2$	$B_3$	h	A				$r_{s \min}$
mm											kN		kN	
160	320	95	306,0	226,0		34	91,0		45,0	99	5,0	1460	4810	451,09
170	280	67	253,6	214,6	42,2	24	-	60,0	32,0	96	3,0	1058	4098	391,84
	280	67	258,0	215,0		23	64,0		32,0	96	3,0	833	2950	282,07
	340	103	324,0	240,0		37	99,0		50,0	104	5,0	1620	5380	495,46
180	300	73	270,4	228,3	46,0	26	-	64,3	35,5	103	3,0	1243	4813	451,38
	300	73	277,0	231,0		25	69,0		35,0	103	3,0	984	3530	331,05
	360	109	342,0	255,0		39	105,0		52,0	110	5,0	1800	6010	544,07
190	320	78	294,0	246,0		27	74,0		38,0	110	4,0	1120	4010	369,29
	320	78	284,4	239,5	49,0	28		68,0	36,0	110	4,0	1440	4840	445,73
	380	115	360,0	270,0		41	111,0		55,0	117	5,0	1960	6610	588,75
200	280	48	264,0	233,0	32,0	17	45,0		24,0	108	2,1	710	3150	295,42
	340	85	325,0	261,0		29	81,0		41,0	116	4,0	1300	4740	429,10
	340	85	302,8	253,6	53,5	29		73,0	40,0	116	4,0	1620	5480	496,09
	400	122	365,0	284,0		43	117,0		59,0	122	5,0	2210	7510	658,70
220	300	48	286,0	252,0		17	46,0		24,0	117	2,0	735	3350	306,72
	360	85	345,0	280,0		29	81,0		41,0	125	4,0	1340	4970	440,38
	360	85	324,4	273,0	55,0	29		74,0	41,0	125	4,0	1740	6300	558,22
	420	122	400,0	305,0		43	117,0		58,0	132	6,0	2260	7970	685,65
240	340	60	330,0	283,0		19	57,0		30,0	130	2,1	770	3450	305,69
	380	85	365,0	300,0		29	81,0		41,0	135	4,0	1340	5190	450,76
	380	85	343,7	294,8	54,0	29		75,0	40,5	135	4,0	1790	6490	563,67
	440	122	420,0	321,0		43	117,0		59,0	142	6,0	2340	8420	711,30
260	360	60	350,0	302,0		19	57,0		30,0	139	2,1	801	3650	317,01
	420	95	405,0	325,0		32	91,0		45,0	148	5,0	1780	6820	576,14
	420	95	380,3	320,4	61,0	32		84,0	46,0	148	5,0	2240	8310	702,01
	480	132	460,0	346,0		48	127,0		64,0	154	6,0	2730	9870	812,91
280	380	60	370,0	323,0		19	57,0		30,0	150	2,1	847	3950	336,69
	440	95	423,0	345,0		32	91,0		46,0	158	5,0	1780	7100	589,59
	440	95	401,7	342,1	62,0	32		84,0	45,0	158	5,0	2310	8490	705,02
	520	145	495,0	380,0		52	140,0		68,0	166	6,0	3230	11840	952,62
	520	145	468,9	370,0	95,0	52		125,0	70,0	166	6,0	4470	15750	1267,21
300	420	73	405,0	355,0		21	69,0		38,0	162	3,0	1030	4670	387,80
	480	109	460,0	375,0		37	105,0		50,0	168	5,0	2180	8500	689,11
	480	109	431,9	366,7	70,0	36		95,0	51,0	168	5,0	2650	11000	891,78
	540	145	515,0	398,0		52	140,0		70,0	175	6,0	3220	11850	939,57
	540	145	489,2	370,0	95,0	55		125,0	70,0	175	6,0	4510	16460	1305,09
320	440	73	430,0	375,0		21	69,0		38,0	172	3,0	1070	4930	402,81
	500	109	482,0	395,0		37	105,0		53,0	180	5,0	2180	8850	706,80
	500	109	456,1	387,0	78,0	37		95,0	53,0	180	5,0	2850	10920	872,11
	580	155	555,0	430,0		55	149,0		75,0	191	7,5	3890	14690	1140,89
	580	155	525,6	422,0	102,0	55		134,0	74,5	191	7,5	5010	21200	1646,49

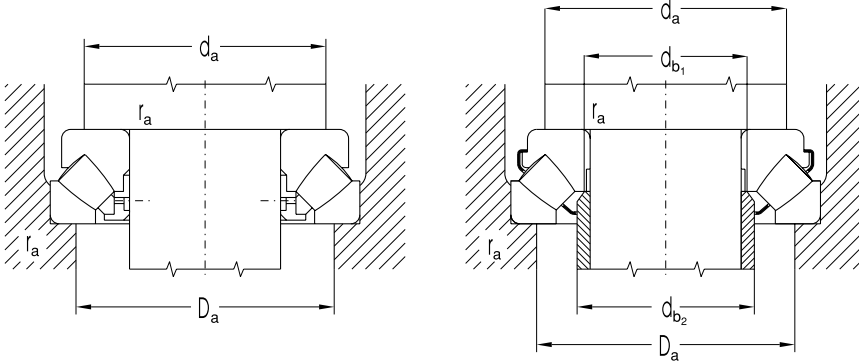

Limiting Speed for Lubrication with Oil	Bearing Designation	Abutment and Fillet Dimensions						Weight	Minimum Axial Load Factor
		d	d <sub>a</sub> min	d <sub>b1</sub> max	D <sub>a</sub> max	d <sub>b2</sub> min	r <sub>a</sub> max		
min <sup>-1</sup>		mm						kg	M
1000	<b>29332M</b>	160	230		274		4,00	35,50	2,900
1200	<b>29334EJ</b>	170	220	178,0	245	188,0	2,50	15,10	2,100
1100	<b>29334M</b>		220		248		2,50	16,00	1,100
940	<b>29434M</b>		245		291		4,00	43,70	3,600
1100	<b>29336EJ</b>	180	235	189,0	262	195,0	2,50	19,10	2,900
1000	<b>29336M</b>		235		266		2,50	20,30	1,600
890	<b>29436M</b>		260		307		4,00	52,00	4,500
940	<b>29338M*</b>	190	250		283		3,00	24,80	2,000
1100	<b>29338EJ</b>		250	199,0	280	208,5	3,00	23,30	2,900
840	<b>29438M</b>		275		325		4,00	60,00	5,500
1150	<b>29240EM</b>	200	235		260		2,00	8,76	1,400
890	<b>29340M*</b>		265		300		3,00	33,00	2,800
950	<b>29340EJ</b>		265	211,0	300	221,5	3,00	28,90	3,100
790	<b>29440M</b>		290		343		4,00	69,00	7,100
1300	<b>29244EM</b>	220	285		260		2,00	9,64	1,400
840	<b>29344M*</b>		285		320		3,00	32,80	3,100
950	<b>29344EJ</b>		285	229,0	316	237,5	3,00	31,60	5,000
750	<b>29444M</b>		310		364		5,00	74,00	7,900
890	<b>29248M</b>	240	285		311		2,00	16,70	1,500
790	<b>29348M*</b>		300		340		3,00	35,30	3,400
900	<b>29348EJ</b>		305	249,0	336	256,0	3,00	33,40	5,300
750	<b>29448M</b>		330		383		5,00	79,00	8,900
890	<b>29252M</b>	260	305		331		2,00	18,50	1,700
750	<b>29352M*</b>		330		374		3,00	48,50	5,800
800	<b>29352EJ</b>		335	272,0	370	283,2	4,00	46,90	8,600
670	<b>29452M</b>		360		419		5,00	105,00	12,000
840	<b>29256M</b>	280	325		351		2,00	19,50	2,000
710	<b>29356M*</b>		350		394		4,00	52,50	6,300
800	<b>29356EJ</b>		355	293,0	390	302,0	4,00	49,50	9,000
630	<b>29456M*</b>		390		453		5,00	132,00	18,000
630	<b>29456EJ</b>		395	298,0	446	316,5	5,00	127,00	31,000
750	<b>29260M</b>	300	355		386		2,50	30,50	2,700
630	<b>29360M*</b>		380		429		4,00	74,00	9,000
700	<b>29360EJ</b>		385	312,0	423	325,8	4,00	68,70	15,000
600	<b>29460M*</b>		410		471		5,00	140,00	18,000
600	<b>29460EJ</b>		415	318,0	465	339,0	5,00	133,00	34,000
710	<b>29264M</b>	320	375		406		2,50	32,90	3,000
630	<b>29364M*</b>		400		449		4,00	77,00	9,800
670	<b>29364EJ</b>		405	332,0	442	336,0	4,00	72,10	15,000
560	<b>29464M*</b>		435		507		6,00	175,00	27,000
560	<b>29464EJ</b>		450	342,0	500	364,0	6,00	164,00	56,000

Deliveries of bearings marked with \* must be agreed with the producer.

# Spherical Roller Thrust Bearings

d = 340 to 800 mm

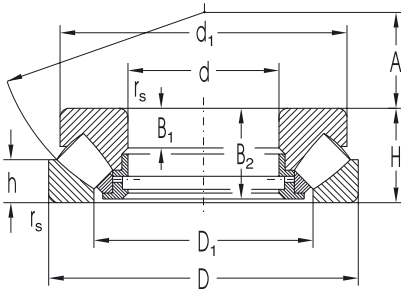

M, EM

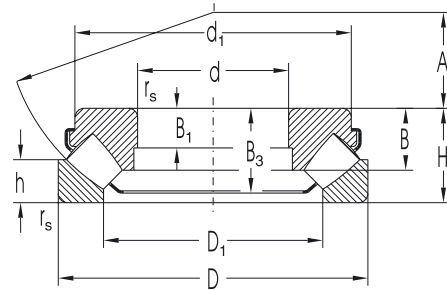

EJ

Dimensions												Basic Load Dynamic $C_a$	Rating Static $C_{oa}$	Fatigue load limit $P_u$
d	D	H	$d_1$	$D_1$	B	$B_1$	$B_2$	$B_3$	h	A	$r_{s \min}$			
mm												kN		kN
340	460	73	436,0	389,5	-	21	69,0	-	37,0	183	3,0	1400	6600	531,02
	540	122	520,0	424,0		41	117,0		59,0	192	5,0	2640	10550	824,90
	620	170	561,8	442,2	112,0	54	-	146,0	84,0	201	7,5	5820	25080	1910,47
360	620	170	590,0	452,0		61	164,0		82,0	201	7,5	4350	16410	1250,04
	500	85	485,0	420,0		25	81,0		44,0	194	4,0	1400	6600	519,62
380	560	122	540,0	444,0		41	117,0		59,0	202	5,0	2650	11030	851,01
	520	85	505,0	440,0		27	81,0		42,0	202	4,0	1550	7510	583,26
400	670	175	622,0	504,0		63	168,0		85,0	222	7,5	4700	19100	1416,35
	540	85	526,0	460,0		27	81,0		42,0	212	4,0	1600	7900	605,60
	620	132	596,0	494,0		44	127,0		64,0	225	6,0	3290	14120	1056,21
420	710	185	680,0	530,0		67	178,0		89,0	236	7,5	6810	26500	1932,61
	580	95	553,0	484,2	-	30	91,0		46,0	225	5,0	2300	11230	845,04
440	650	140	626,0	520,0		48	135,0		68,0	235	6,0	3410	14700	1083,92
	730	185	663,0	540,0		67	175,0		90,0	244	7,5	6850	31020	2238,35
	680	145	655,0	546,0		49	140,0		70,0	245	6,0	3860	16850	1225,55
480	780	206	745,0	576,0		74	199,0		100,0	260	9,5	6280	24650	1747,45
	850	224	772,0	611,6		81	214,0		108,0	280	9,5	9646	44398	3066,92
500	670	103	654,0	574,0		33	99,0		55,0	268	5,0	2400	12120	870,05
	750	150	725,0	611,0		51	144,0		74,0	280	6,0	4220	18660	1313,21
	870	224	801,0	625,6	-	81	218,0		110,0	290	9,5	10025	48568	3325,29
530	800	160	772,0	648,0		54	154,0		76,0	295	7,5	5130	22730	1570,14
600	800	122	760,0	680,0		44	117,0		60,0	321	5,0	3720	19060	1296,52
	900	180	850,0	731,0		64	171,0		87,0	335	7,5	6800	31500	2098,84
630	850	132	820,0	724,0		42	127,0		67,0	338	6,0	4250	22500	1505,22
670	900	140	858,0	762,0		50	130,0		73,0	361	6,0	4500	23280	1530,06
710	1220	308	1110,0	899,0		118	298,0		149,0	415	15,0	17600	76500	4725,95
800	1360	335	1300,0	1040,0		120	324,0		162,0	462	15,0	16340	72360	4321,73

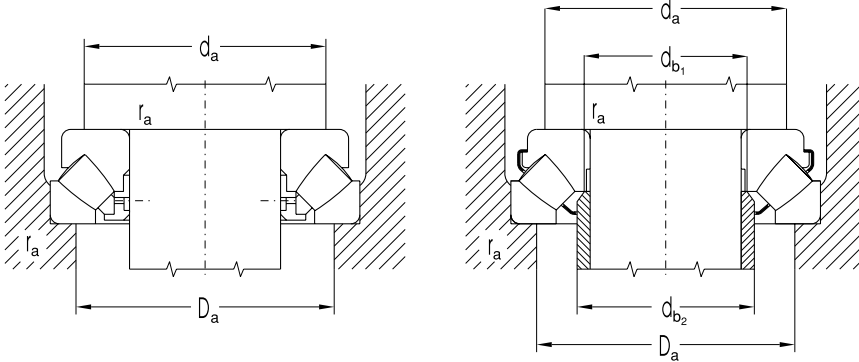

Limiting Speed for Lubrication with Oil	Bearing Designation	Abutment and Fillet Dimensions						Weight ~	Minimum Axial Load Factor M
		d	d <sub>a min</sub>	d <sub>b1 max</sub>	D <sub>a max</sub>	d <sub>b2 min</sub>	r <sub>a max</sub>		
min <sup>-1</sup>		mm						kg	
850	<b>29268EM</b>	340	400	-	422	-	2,50	33,00	5,400
560	<b>29368M</b>		430		484		4,00	103,00	14,000
380	<b>29468EJ</b>		475	358,0	530	364,0	6,00	211,00	79,000
500	<b>29468M</b>		465		451		6,00	218,00	34,000
630	<b>29272M</b>	360	420		461		3,00	51,80	5,400
560	<b>29372M</b>		450		504		4,00	107,00	15,000
600	<b>29276M</b>	380	440		480		3,00	52,80	7,100
470	<b>29476EM</b>		504		570		6,00	263,00	46,000
600	<b>29280M</b>	400		460	500	3,0		55,30	7,800
500	<b>29380M</b>			498	557	5,0		150,00	25,000
450	<b>29480EM</b>			550	615	6,0		306,00	88,000
700	<b>29284EM</b>	420	500	-	525	-	4,00	73,00	16,000
450	<b>29384M</b>			523	585	5,0		170,00	27,000
430	<b>29484EM</b>			592	684	8,0		308,00	63,000
450	<b>29388M</b>	440		548	614	5,0		190,00	35,000
400	<b>29488M</b>			592	684	8,0		407,00	76,000
340	<b>29496EM</b>			660	735	8,0		518,00	82,000
470	<b>292/500M</b>	500		578	622	4,0		101,00	18,000
400	<b>293/500M</b>			613	680	5,0		220,00	44,000
340	<b>294/500EM</b>		685	-	755	-	8,00	548,00	290,000
380	<b>293/530M</b>	530		651	724	6,0		286,00	65,000
450	<b>292/600EM</b>	600	700		725		4	160,0	45,0
330	<b>293/600EM</b>	600		735	815	6,0		390,00	120,000
350	<b>292/630M</b>	630		730	789	5,0		211,00	63,000
380	<b>292/670EM</b>	670	790		815		5	237,0	68,0
220	<b>T 294/710</b>	710	970		1050		12	1420,0	730,0
220	<b>294/800M</b>	800		1055	1200	12,0		2010,00	650,000



# Insert Ball Bearings and Insert Ball Bearing Units

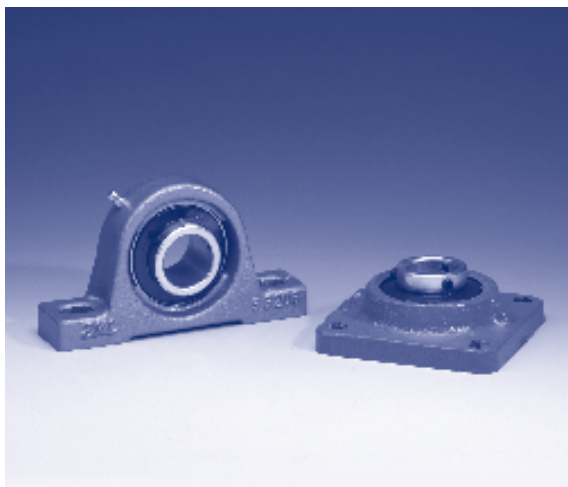

Insert ball bearings are single row deep groove ball bearings with double sealing on both sides. The outer ring has a spherical surface and that is why it can tilt in the housing with the same spherical surface. It can accommodate eventual misalignments. The inner bearing ring is wider than the outer one and it is fixed on the shaft :

- by means of eccentric locking collar, design UA
- by means of screws, design UC

Bearings are filled with grease for the whole bearing life. Housing designs allow eventual relubrication by means of a lubricating nipple.

Bearings are suitable for arrangements on short shafts and for arrangements where small thermal contraction occur which are compensated by bearing axial clearance or design adaptability, on which bearing housings are fixed.

The material of insert ball bearing housings are grey cast iron or steel sheet and from the point of view of design the housings can be in pillow block - designation SG, SA or flanged - designation FG, FM, FB, FE. In the housing there is a spherical hollow and they form together a unit which enables an economic solution with a simple arrangement design. They are used in agricultural machines, transportation equipments, food-making machines, etc.

## Boundary Dimensions

Boundary dimensions of insert ball bearings correspond to the standard ISO 2264, ISO 3228 and bearing housings and eccentric locking collars to the standard ISO 3145.

## Designation

Designation of insert ball bearings, corresponding housings and complete units is in the dimension tables of this publication.

## Cage

Bearings have cages pressed of steel which are not designated.

## Tolerance

Bearings have a uniform bore diameter tolerance H6. This tolerance secures by shaft machining in the tolerance h always a loose fit. For shaft manufacturing usually tolerances h8 and h11 are sufficient. For greater loads and rotational speeds it is necessary to select tolerances h6, h7.

## Radial Clearance

Commonly manufactured insert ball bearings have normal radial clearance which is not indicated and its size and extent is the same as for single row deep groove ball bearings of the same dimensions.

Delivery of bearings with different radial clearance should be discussed with the supplier in advance.



## Limiting Rotational Speed

This parameter is dependent on the arrangement on the shaft and from the point of view of shaft diameter the dependence in the dimension tables is worked out.



# Insert Ball Bearings

d = 20 to 40 mm

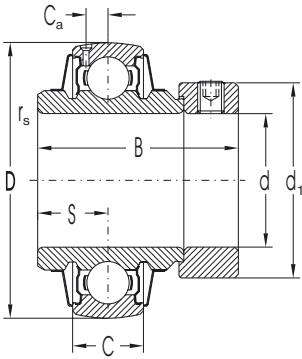

UA

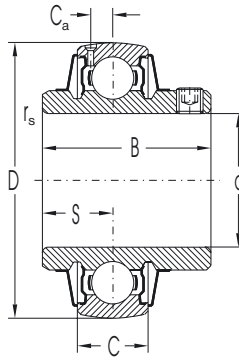

UC

Dimensions								Basic Load Rating		Bearing Designation	Weight
d	D	B	C	rs min	d1 max	S	Ca	Cr	C <sub>or</sub>		
mm								kN			kg
20	47	31.4	14	1.0		12.7	4.1	12.77	6.56	<b>UC204</b>	0.146
25	52	44.4	15	1.0	38.0	17.5	4.1	14.0	7.90	<b>UA205</b>	0.230
	52	34.1	15	1.0		14.3	4.1	14.0	7.90	<b>UC205</b>	0.170
	52		15	1.0		7.5		14.0	7.90	<b>UD205</b>	0.126
	52	31.0	15	0.6	38.0	7.5		14.0	7.90	<b>UE205</b>	0.180
	52	27.7	15	1.0		7.5		14.0	7.90	<b>US205</b>	0.150
30	62	48.4	16	1.0	45.0	18.3	4.8	19.4	11.20	<b>UA206</b>	0.360
	62	38.1	16	1.0		15.9	4.8	19.4	11.20	<b>UC206</b>	0.280
	62		16	1.0		8.0		19.4	11.20	<b>UD206</b>	0.195
	62	35.7	16	0.6	45.0	8.0		19.4	11.20	<b>UE206</b>	0.280
	62	30.3	16	1.0		8.0		19.4	11.20	<b>US206</b>	0.210
35	72	51.1	17	1.1	56.5	18.8	5.3	25.6	15.20	<b>UA207</b>	0.550
	72	42.9	17	1.1		17.5	5.3	25.6	15.20	<b>UC207</b>	0.410
	72		17	1.1		8.5		25.6	15.20	<b>UD207</b>	0.278
	72	38.9	17	0.6	56.5	9.5		25.6	15.20	<b>UE207</b>	0.420
	72	34.0	17	1.1		8.5		25.6	15.20	<b>US207</b>	0.330
40	80	56.3	18	1.1	60.0	21.4	5.9	32.6	19.80	<b>UA208</b>	0.700
	80	49.2	18	1.1		19.0	5.9	32.6	19.80	<b>UC208</b>	0.550
	80		18	1.1		9.0		32.6	19.80	<b>UD208</b>	0.360
	80	43.7	18	0.6	60.0	11.0		32.6	19.80	<b>UE208</b>	0.570
	80	39.5	18	1.1		9.0		32.6	19.80	<b>US208</b>	0.450

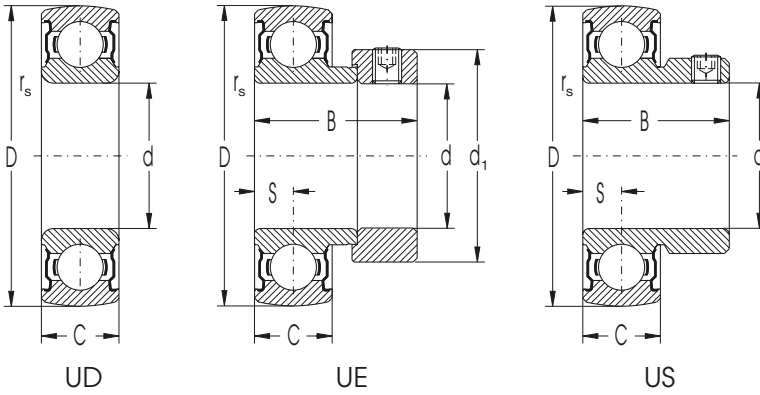

Limiting Speed for Lubrication with Grease  
Shaft Diameter Tolerance

	h6	h7	h8	h9	h11
min <sup>-1</sup>					
8500	5300	3800	1300	850	
7100	4500	3200	1000	710	
7100	4500	3200	1000	710	
7100	4500	3200	1000	710	
7100	4500	3200	1000	710	
6300	4000	2800	890	630	
6300	4000	2800	890	630	
6300	4000	2800	890	630	
6300	4000	2800	890	630	
5300	3300	2200	750	530	
5300	3300	2200	750	530	
5300	3300	2200	750	530	
5300	3300	2200	750	530	
4700	3000	1900	670	470	
4700	3000	1900	670	470	
4700	3000	1900	670	470	
4700	3000	1900	670	470	





















# Spherical Plain Bearings



Spherical plain bearings are radial sliding bearings consisting of one inner and one outer ring which have spherical functional surfaces. Bearings are determined for arrangements where great radial forces at slow tilting or oscillating are acting and for arrangements where space adjustability of both components is secured. Besides radial load, bearings can also accommodate an axial load of certain magnitude in both directions.

Spherical plain bearings are produced of bearing steel. Rings are hardened, ground or phosphatized. Spherical plain bearings require minimum service. At first mounting the bearings are filled with grease and are relubricated in certain time periods according to operating conditions. For spherical plain bearings lubrication mainly greases with EP or MoS<sub>2</sub> additives are suitable.

## Boundary Dimensions

Boundary dimensions of spherical plain bearings - Type GE comply with the international standard ISO 6124/1 and bearings - type GEW with enlarged inner ring the international standard ISO 6124/2.

## Designation

Spherical plain bearings designation in standard design is shown in the dimension table and consists of type designation (GE or GEW) and size (digit indicates bore diameter in mm), e.g. GE30. Deviations from standard design (radial clearance, sealing, dimension change) are indicated by additional symbols according to ISO D2 4608 (except for symbol E), placed after the basic designation. Symbol E - phosphatized bearing surface, e.g. GE30E.

## Tolerance

Spherical plain bearings are produced in normal tolerance class which is not indicated. Deviation values correspond to the international standard ISO 6125.

## Radial Clearance

Spherical plain bearings are commonly produced with normal radial clearance which is not indicated. Radial clearance values are shown in the following table.

Bore Diameter		Radial Clearance					
over	to	C2		normal		C3	
		min	max	min	max	min	max
mm		µm					
12	20	10	40	40	82	82	124
20	35	12	50	50	100	100	150
35	60	15	60	60	120	120	180







# Accessories of Rolling Bearing

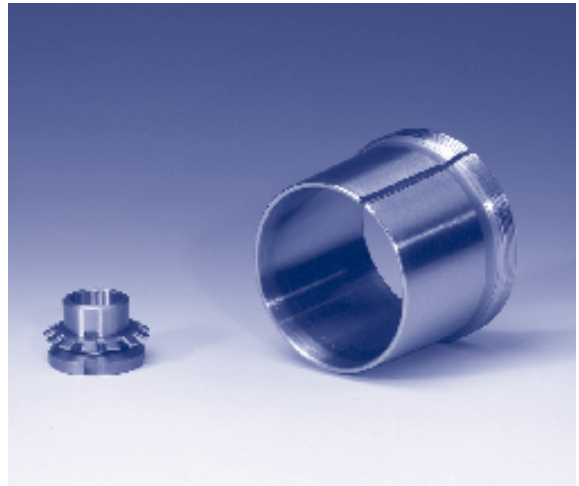

Machine components serving for fixing rolling bearings on the shaft or in the housing bore are involved in this category of accessories.

## **Adapter Sleeves**

Adapter sleeves are used for fixing double row self-aligning ball bearings and double row spherical roller bearings with tapered bore (K) on cylindrical shafts. Material for adapter sleeves is steel with tensile strength 400 to 600 MPa.

Boundary dimensions of adapter sleeves are in the dimension tables and correspond to the standard ISO 113/1.

Adapter sleeve designation including nuts and locking devices is in the dimension tables. Adapter sleeve utilization for individual bearings with tapered bore is indicated in the corresponding part devoted to double row self-aligning and double row spherical roller bearings.

Abutment and fillet dimensions for bearings with adapter sleeves are shown in the following table.



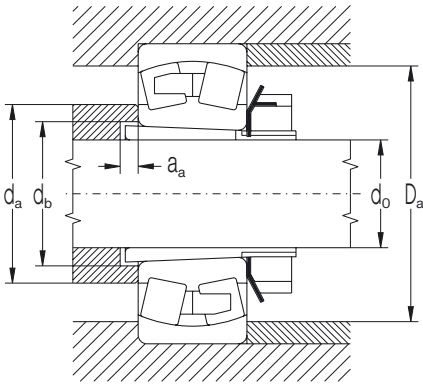

Nominal Diameter	Adapter Sleeve Type																				
	H2		H3				H23			H30		H31			H32						
	Bearing Dimension Series																				
d	d <sub>0</sub>	02		22		03			32		23		30		31		22		32		
		d <sub>b</sub> min	a <sub>a</sub> min	d <sub>b</sub> min	a <sub>a</sub> min	d <sub>b</sub> min	a <sub>a</sub> min	23	d <sub>b</sub> min	a <sub>a</sub> min	d <sub>b</sub> min	a <sub>a</sub> min	d <sub>b</sub> min	a <sub>a</sub> min	d <sub>b</sub> min	a <sub>a</sub> min	d <sub>b</sub> min	a <sub>a</sub> min	d <sub>b</sub> min	a <sub>a</sub> min	
mm																					
20	17	23	5	23	5	8	24	-	5	-	-	-	-	-	-	-	-	-	-	-	
25	20	28	5	28	5	6	30	-	5	-	-	-	-	-	-	-	-	-	-	-	
30	25	33	5	33	5	6	35	-	5	-	-	-	-	-	-	-	-	-	-	-	
35	30	38	5	39	5	8	40	-	5	-	-	-	-	-	-	-	-	-	-	-	
40	35	43	5	44	5	5	45	-	5	-	-	-	-	-	-	-	-	-	-	-	
45	40	48	5	50	8	5	50	-	5	-	-	-	-	-	-	-	-	-	-	-	
50	45	53	5	55	10	5	56	-	5	-	-	-	-	-	-	-	-	-	-	-	
55	50	60	6	60	19	6	61	-	6	-	-	-	-	-	-	-	-	-	-	-	
60	55	64	5	65	8	5	66	-	5	-	-	-	-	-	-	-	-	-	-	-	
65	60	70	5	70	8	5	72	-	5	-	-	-	-	-	-	-	-	-	-	-	
70	60	75	5	75	10	5	76	-	5	-	-	-	-	-	-	-	-	-	-	-	
75	65	80	5	80	12	5	82	-	5	-	-	-	-	-	-	-	-	-	-	-	
80	70	85	5	85	12	5	88	-	5	-	-	-	-	-	-	-	-	-	-	-	
85	75	90	6	91	12	6	94	-	6	-	-	-	-	-	-	-	-	-	-	-	
90	80	95	6	96	10	6	100	18	6	-	-	-	-	-	-	-	-	-	-	-	
100	90	106	7	108	8	7	110	19	7	-	-	-	-	-	-	-	-	-	-	-	
110	100	116	7	118	6	9	121	17	7	-	-	117	7	-	-	-	-	-	-	-	
120	110	-	-	-	-	-	131	17	7	127	7	128	7	11	-	-	-	-	-	-	
130	115	-	-	-	-	-	142	21	8	137	8	138	8	8	-	-	-	-	-	-	
140	125	-	-	-	-	-	152	22	8	147	8	149	8	8	-	-	-	-	-	-	
150	135	-	-	-	-	-	163	20	8	158	8	160	8	15	-	-	-	-	-	-	
160	140	-	-	-	-	-	174	18	8	168	8	170	8	14	-	-	-	-	-	-	
170	150	-	-	-	-	-	185	18	8	179	8	180	8	10	-	-	-	-	-	-	
180	160	-	-	-	-	-	195	22	8	189	8	191	8	18	-	-	-	-	-	-	
190	170	-	-	-	-	-	206	21	9	199	9	202	9	21	-	-	-	-	-	-	
200	180	-	-	-	-	-	216	20	10	210	10	212	10	24	-	-	-	-	-	-	
220	200	-	-	-	-	-	236	11	10	231	12	233	10	22	-	-	-	-	-	-	
240	220	-	-	-	-	-	257	6	11	251	11	254	11	19	-	-	-	-	-	-	
260	240	-	-	-	-	-	278	2	11	171	13	276	11	25	-	-	-	-	-	-	
280	260	-	-	-	-	-	299	11	12	292	12	296	12	28	-	-	-	-	-	-	
300	280	-	-	-	-	-	-	-	-	313	12	318	12	32	-	-	-	-	321	12	-
320	300	-	-	-	-	-	-	-	-	334	13	338	13	39	-	-	-	-	343	13	-
340	320	-	-	-	-	-	-	-	-	355	14	360	14	-	-	-	-	-	-	-	-
360	340	-	-	-	-	-	-	-	-	375	14	380	14	-	-	-	-	-	-	-	-

Abutment and fillet dimensions  $d_{a\min}$ ,  $D_{a\max}$ ,  $a_r$  are shown in dimension tables of double row self-aligning and double row spherical roller bearings.

## Withdrawal Sleeves

Withdrawal sleeves are used for fixing double row spherical roller bearings with tapered bore (K) on cylindrical shafts. Withdrawal sleeve material is steel with tensile strength 400 to 600 MPa.

Boundary dimensions of withdrawal sleeves and corresponding withdrawal nuts, which must be ordered separately, correspond to the standard ISO 2982.

Withdrawal sleeve and corresponding withdrawal nut designation to individual double row spherical roller bearings with tapered bore is shown in dimension tables devoted to these bearings.

Abutment and fillet dimensions for bearings with withdrawal sleeves ( $d_{a,min}$ ,  $D_{a,max}$ ,  $r_{a,max}$ ) are the same as for bearings without withdrawal sleeves and are indicated in corresponding dimension tables.

## Locknuts and Withdrawal Nuts

Locknuts and withdrawal nuts are used for fixing inner bearing rings on adapter sleeves or directly on the shaft. Withdrawal nuts serve for dismounting of double row spherical roller bearings with tapered bore fixed by means of a withdrawal sleeve. Material for nuts is steel with minimum tensile strength 410 MPa.

Boundary dimensions of locknuts and withdrawal nuts shown in the dimension tables correspond to the standard ISO 2982.

Locknuts are produced in normal design (type KM) and in precision design (type KMA) and are shown in the dimension tables of this publication. When determining the axial runout parameter, following table is valid:

Nut Size Designation		Limiting Axial Runout Values of Abutment Face	
over	to	KM	KMA
		mm	
	10	0,04	0,025
10	20	0,05	0,030
20	25	0,05	0,030
25	30	0,06	0,040
30	40	0,06	0,050

## Locking Washers

Locking washers serve for locating of locknuts and are produced of steel with minimum tensile strength 274 MPa. Locking washer boundary dimensions are in the dimension tables of this publication and correspond to the standard ISO 2982.

## Snap Rings for Bearings with Snap Ring Groove on Outer Ring

Snap rings are used for simple axial fixing of bearings with a groove on outer ring (N) in housings. Material for snap rings is spring steel. Boundary dimensions for snap rings correspond to the standard ISO 464.

Snap rings are designated by a number indicating the outer bearing diameter  $D$  and a number indicating minimum snap ring width  $f$ , e.g. 52/1.02.

In practice also a commercial designation which indicates the ring type R and outer bearing diameter in mm, e.g. R52, is used.

In the dimension tables snap rings for single row ball bearings - type 60, 62, 63 and 64 in N design are shown.

Snap rings can also be used also for bearings in different design, their delivery should be discussed with supplier in advance. Snap rings are delivered separately.

# Adapter Sleeves

$d_0 = 20$  to 75 mm

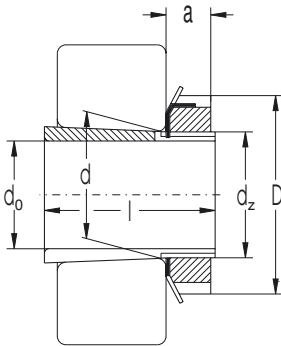

Dimensions						Sleeve Designation incl. Nut and Locking	Appropriate Components		Weight
$d_0$	$d$	$d_z$	D	L	a		Nut	Locking	
mm									kg
20	25	M25x1.5	38	26	8	<b>H205</b>	KM5	MB5	0.070
	25	M25x1.5	38	29	8	<b>H305</b>	KM5	MB5	0.075
	25	M25x1.5	38	35	8	<b>H2305</b>	KM5	MB5	0.087
25	30	M30x1.5	45	27	8	<b>H206</b>	KM6	MB6	0.099
	30	M30x1.5	45	31	8	<b>H306</b>	KM6	MB6	0.109
	30	M30x1.5	45	38	8	<b>H2306</b>	KM6	MB6	0.126
30	35	M35x1.5	52	29	9	<b>H207</b>	KM7	MB7	0.125
	35	M35x1.5	52	35	9	<b>H307</b>	KM7	MB7	0.142
	35	M35x1.5	52	43	9	<b>H2307</b>	KM7	MB7	0.165
35	40	M40x1.5	58	31	10	<b>H208</b>	KM8	MB8	0.174
	40	M40x1.5	58	36	10	<b>H308</b>	KM8	MB8	0.189
	40	M40x1.5	58	46	10	<b>H2308</b>	KM8	MB8	0.224
40	45	M45x1.5	65	33	11	<b>H209</b>	KM9	MB9	0.227
	45	M45x1.5	65	39	11	<b>H309</b>	KM9	MB9	0.248
	45	M45x1.5	65	50	11	<b>H2309</b>	KM9	MB9	0.280
45	50	M50x1.5	70	35	12	<b>H210</b>	KM10	MB10	0.274
	50	M50x1.5	70	42	12	<b>H310</b>	KM10	MB10	0.303
	50	M50x1.5	70	55	12	<b>H2310</b>	KM10	MB10	0.362
50	55	M55x2	75	37	12	<b>H211</b>	KM11	MB11	0.308
	55	M55x2	75	45	12	<b>H311</b>	KM11	MB11	0.345
	55	M55x2	75	59	12	<b>H2311</b>	KM11	MB11	0.420
55	60	M60x2	80	38	13	<b>H212</b>	KM12	MB12	0.346
	60	M60x2	80	47	13	<b>H312</b>	KM12	MB12	0.394
	60	M60x2	80	62	13	<b>H2312</b>	KM12	MB12	0.481
60	65	M65x2	85	40	14	<b>H213</b>	KM13	MB13	0.401
	65	M65x2	85	50	14	<b>H313</b>	KM13	MB13	0.458
	65	M65x2	85	65	14	<b>H2313</b>	KM13	MB13	0.557
65	75	M75x2	98	43	15	<b>H215</b>	KM15	MB15	0.707
	75	M75x2	98	55	15	<b>H315</b>	KM15	MB15	0.831
	75	M75x2	98	73	15	<b>H2315</b>	KM15	MB15	1.050
70	80	M80x2	105	46	17	<b>H216</b>	KM16	MB16	0.882
	80	M80x2	105	59	17	<b>H316</b>	KM16	MB16	1.030
	80	M80x2	105	78	17	<b>H2316</b>	KM16	MB16	1.280
75	85	M85x2	110	50	18	<b>H217</b>	KM17	MB17	1.020
	85	M85x2	110	63	18	<b>H317</b>	KM17	MB17	1.180
	85	M85x2	110	82	18	<b>H2317</b>	KM17	MB17	1.450



## Adapter Sleeves

$d_0 = 80$  to 180 mm

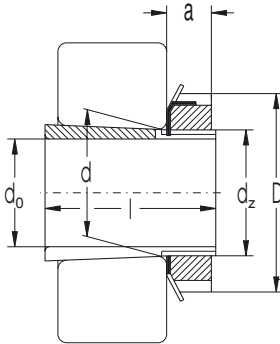

Dimensions						Sleeve Designation incl. Nut and Locking	Appropriate Components		Weight
$d_0$	$d$	$d_2$	$D$	$L$	$a$		Nut	Locking	
mm									kg
80	90	M90x2	120	62	18	<b>H218</b>	KM18	MB18	1.190
	90	M90x2	120	65	18	<b>H318</b>	KM18	MB18	1.370
	90	M90x2	120	86	18	<b>H2318</b>	KM18	MB18	1.690
85	95	M95x2	125	55	19	<b>H219</b>	KM19	MB19	1.370
	95	M95x2	125	68	19	<b>H319</b>	KM19	MB19	1.560
	95	M95x2	125	90	19	<b>H2319</b>	KM19	MB19	1.920
90	100	M100x2	130	58	20	<b>H220</b>	KM20	MB20	1.490
	100	M100x2	130	71	20	<b>H320</b>	KM20	MB20	1.690
	100	M100x2	130	97	20	<b>H2320</b>	KM20	MB20	2.150
100	110	M110x2	145	81	21	<b>H3122</b>	KM22	MB22	2.250
	110	M110x2	145	63	21	<b>H222</b>	KM22	MB22	1.930
	110	M110x2	145	77	21	<b>H322</b>	KM22	MB22	2.180
	110	M110x2	145	105	21	<b>H2322</b>	KM22	MB22	2.740
110	120	M120x2	145	72	22	<b>H3024</b>	KML24	MBL24	1.930
	120	M120x2	155	88	22	<b>H3124</b>	KM24	MB24	2.640
	120	M120x2	155	112	22	<b>H2324</b>	KM24	MB24	3.190
115	130	M130x2	155	80	23	<b>H3026</b>	KML26	MBL26	2.850
	130	M130x2	165	92	23	<b>H3126</b>	KM26	MB26	3.660
	130	M130x2	165	121	23	<b>H2326</b>	KM26	MB26	4.600
125	140	M140x2	165	82	24	<b>H3028</b>	KML28	MBL28	3.160
	140	M140x2	180	97	24	<b>H3128</b>	KM28	MB28	4.340
	140	M140x2	180	131	24	<b>H2328</b>	KM28	MB28	5.550
135	150	M150x2	180	87	26	<b>H3030</b>	KML30	MBL30	3.890
	150	M150x2	195	111	26	<b>H3130</b>	KM30	MB30	5.520
	150	M150x2	195	139	26	<b>H2330</b>	KM30	MB30	6.630
140	160	M160x3	190	93	28	<b>H3032</b>	KML32	MBL32	5.210
	160	M160x3	210	119	28	<b>H3132</b>	KM32	MB32	7.670
	160	M160x3	210	147	28	<b>H2332</b>	KM32	MB32	9.140
150	170	M170x3	200	101	29	<b>H3034</b>	KML34	MBL34	5.990
	170	M170x3	220	122	29	<b>H3134</b>	KM34	MB34	8.360
	170	M170x3	220	154	29	<b>H2334</b>	KM34	MB34	10.200
160	180	M180x3	210	109	30	<b>H3036</b>	KML36	MBL36	6.830
	180	M180x3	230	131	30	<b>H3136</b>	KM36	MB36	9.500
	180	M180x3	230	161	30	<b>H2336</b>	KM36	MB36	11.300
170	190	M190x3	220	112	31	<b>H3038</b>	KML38	MBL38	7.450
	190	M190x3	240	141	31	<b>H3138</b>	KM38	MB38	10.800
	190	M190x3	240	169	31	<b>H2338</b>	KM38	MB38	12.600
180	200	M200x3	240	120	32	<b>H3040</b>	KML40	MBL40	9.190
	200	M200x3	250	150	32	<b>H3140</b>	KM40	MB40	12.100
	200	M200x3	250	176	32	<b>H2340</b>	KM40	MB40	13.900

# Withdrawal Sleeves

$d_0 = 35 \text{ to } 95 \text{ mm}$

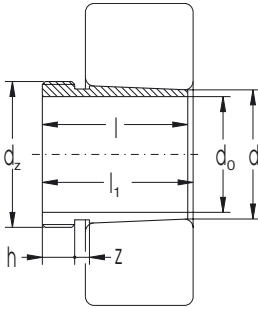

Dimensions							Sleeve Designation	Corresp. Withdrawal Nut	Weight
$d_0$	$d$	$d_z$	$l$	$l_1$	$h$	$z$			
mm									kg
35	40	M45x1.5	30	32	6	5	AH308	KM9	0.093
	40	M45x1.5	40	43	7	6	AH2308	KM9	0.129
40	45	M50x1.5	32	34	6	6	AH309	KM10	0.112
	45	M50x1.5	44	47	7	6	AH2309	KM10	0.163
45	50	M55x2	35	38	7	6	AH310X	KM11	0.138
	50	M55x2	50	53	8	6	AH2310X	KM11	0.236
50	55	M60x2	37	40	7	6	AH311X	KM12	0.162
	55	M60x2	54	57	9	6	AH2311X	KM12	0.257
55	60	M65x2	40	43	8	7	AH312X	KM13	0.194
	60	M65x2	57	61	10	7	AH2312X	KM13	0.299
60	65	M75x2	42	45	8	7	AH313	KM15	0.256
	65	M75x2	61	64	11	7	AH2313	KM15	0.399
65	70	M80x2	44	47	8	7	AH314	KM16	0.290
	70	M80x2	65	68	12	7	AH2314X	KM16	0.466
70	75	M85x2	46	49	8	7	AH315	KM17	0.326
	75	M85x2	69	72	12	7	AH2315X	KM17	0.536
75	80	M90x2	48	52	8	7	AH316	KM18	0.367
	80	M90x2	72	75	12	7	AH2316X	KM18	0.602
80	85	M95x2	52	56	9	7	AH317X	KM19	0.431
	85	M95x2	75	78	13	7	AH2317X	KM19	0.676
85	90	M100x2	53	57	9	7	AH318X	KM20	0.465
	90	M100x2	63	67	10	7	AH3218X	KM20	0.578
	90	M100x2	80	83	14	7	AH2318X	KM20	0.777
90	95	M105x2	57	61	10	8	AH319X	KM21	0.537
	95	M105x2	85	89	15	8	AH2319X	KM21	0.888
95	100	M110x2	59	63	10	8	AH320X	KM22	0.586
	100	M110x2	75	77	12	7	AH3220X	KM22	0.768
	100	M110x2	90	94	15	8	AH2320X	KM22	1.000



## Withdrawal Sleeves

$d_0 = 100$  to  $180$  mm

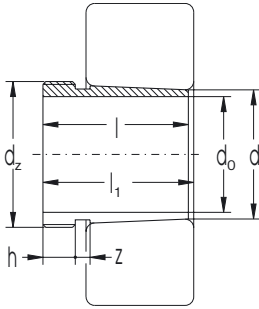

Dimensions							Sleeve Designation	Corresp. Withdrawal Nut	Weight
$d_0$	$d$	$d_z$	$l$	$l_1$	$h$	$z$			
mm									kg
100	110	M125x2	68	72	11	8	AH3122	KM25	1.280
105	110	M120x2	68	72	11	8	AH3122X	KM24	0.786
	110	M125x2	82	86	12	8	AH3222X	KM25	1.060
110	110	M125x2	98	102	16	8	AH322X	KM25	1.350
	120	M140x2	75	79	12	8	AH3124	KM28	1.670
115	120	M140x2	105	109	17	8	AH2324	KM28	2.470
	120	M130x2	60	64	13	8	AH3024X	KM26	0.737
	120	M130x2	75	79	12	8	AH3124X	KM26	0.948
	120	M135x2	90	94	14	8	AH3224X	KM27	1.310
125	120	M135x2	105	109	17	8	AH2324X	KM27	1.610
	130	M140x2	67	71	14	8	AH3026X	KM28	0.907
	130	M140x2	78	82	12	8	AH3126X	KM28	1.080
	130	M145x2	98	102	15	8	AH3226X	KM29	1.580
135	130	M145x2	115	119	19	8	AH2326X	KM29	1.970
	140	M150x2	68	73	14	10	AH3028X	KM30	0.996
	140	M150x2	83	88	14	10	AH3128X	KM30	1.260
	140	M155x3	104	109	15	10	AH3228X	KM31	1.810
145	140	M155x3	125	130	20	10	AH2328X	KM31	2.340
	150	M160x3	72	77	15	10	AH3030X	KM32	1.120
	150	M165x3	96	101	15	10	AH3130X	KM33	1.750
	150	M165x3	114	119	18	10	AH3230X	KM33	2.210
150	150	M165x3	135	140	24	10	AH2330X	KM33	0.000
	160	M170x3	77	82	16	10	AH3032	KM34	2.010
	160	M180x3	103	108	16	10	AH3132	KM36	3.180
	160	M180x3	124	130	20	12	AH3232	KM36	4.020
160	160	M180x3	140	146	24	12	AH2332	KM36	4.690
	170	M180x3	85	90	17	10	AH3034	KM36	2.400
	170	M190x3	104	109	16	10	AH3134	KM38	3.410
	170	M190x3	134	140	24	12	AH3234	KM38	3.410
170	170	M190x3	146	152	24	12	AH2334	KM38	5.230
	180	M190x3	92	98	17	12	AH3036	KM38	2.800
	180	M200x3	116	122	19	12	AH3136	KM40	4.160
	180	M200x3	105	110	17	10	AH2236	KM40	3.670
	180	M200x3	140	146	24	12	AH3236	KM40	5.290
	180	M200x3	154	160	26	12	AH2336	KM40	5.940
180	190	Tr205x4	96	102	17	12	AH3038	HML41T	3.280
	190	Tr210x4	125	131	19	12	AH3138	HM42T	4.730
	190	Tr210x4	112	117	18	10	AH2238	HM42T	4.150
	190	Tr210x4	160	167	26	14	AH2338	HM42T	6.530
	190	Tr210x4	145	152	25	14	AH3238	HM42T	5.800

# Locknuts

d = M10 x 0.75 to M200 x 3

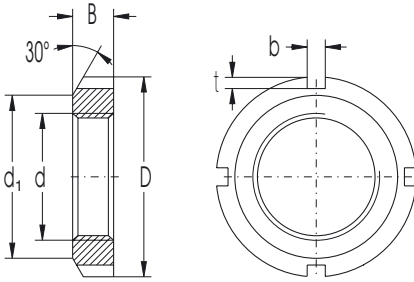

Dimensions						Nut Designation KM	KMA	Corresp. Locking Washer	Weight
d	D	d <sub>1</sub>	B	b	t				
mm									kg
M10x0.75	18	13.5	4	3	2.0	<b>KM0</b>		MB0	0.004
M12x1	22	17	4	3	2.0	<b>KM1</b>		MB1	0.007
M15x1	25	21	5	4	2.0	<b>KM2</b>		MB2	0.010
M17x1	28	24	5	4	2.0	<b>KM3</b>		MB3	0.013
M20x1	32	26	6	4	2.0	<b>KM4</b>		MB4	0.019
M25x1.5	38	32	7	5	2.0	<b>KM5</b>	<b>KMA5</b>	MB5	0.025
M30x1.5	45	38	7	5	2.0	<b>KM6</b>	<b>KMA6</b>	MB6	0.043
M35x1.5	52	44	8	5	2.0	<b>KM7</b>	<b>KMA7</b>	MB7	0.053
M40x1.5	58	50	9	6	2.5	<b>KM8</b>	<b>KMA8</b>	MB8	0.085
M45x1.5	65	56	10	6	2.5	<b>KM9</b>	<b>KMA9</b>	MB9	0.120
M50x1.5	70	61	11	6	2.5	<b>KM10</b>	<b>KMA10</b>	MB10	0.150
M55x2	75	67	11	7	3.0	<b>KM11</b>	<b>KMA11</b>	MB11	0.160
M60x2	80	73	11	7	3.0	<b>KM12</b>	<b>KMA12</b>	MB12	0.170
M65x2	85	79	12	7	3.0	<b>KM13</b>	<b>KMA13</b>	MB13	0.200
M70x2	92	85	12	8	3.5	<b>KM14</b>	<b>KMA14</b>	MB14	0.240
M75x2	98	90	13	8	3.5	<b>KM15</b>	<b>KMA15</b>	MB15	0.290
M80x2	105	95	15	8	3.5	<b>KM16</b>	<b>KMA16</b>	MB16	0.400
M85x2	110	102	16	8	3.5	<b>KM17</b>	<b>KMA17</b>	MB17	0.450
M90x2	120	108	16	10	4.0	<b>KM18</b>	<b>KMA18</b>	MB18	0.560
M95x2	125	113	17	10	4.0	<b>KM19</b>		MB19	0.660
M100x2	130	120	18	10	4.0	<b>KM20</b>	<b>KMA20</b>	MB20	0.700
M105x2	140	126	18	12	5.0	<b>KM21</b>	<b>KMA21</b>	MB21	0.840
M110x2	145	133	19	12	5.0	<b>KM22</b>	<b>KMA22</b>	MB22	0.970
M115x2	150	137	19	12	5.0	<b>KM23</b>		MB23	1.010
M120x2	155	138	20	12	5.0	<b>KM24</b>	<b>KMA24</b>	MB24	1.080
M125x2	160	148	21	12	5.0	<b>KM25</b>	<b>KMA25</b>	MB25	1.190
M130x2	165	149	21	12	6.0	<b>KM26</b>	<b>KMA26</b>	MB26	1.250
M135x2	175	160	22	14	6.0	<b>KM27</b>		MB27	1.550
M140x2	180	160	22	14	6.0	<b>KM28</b>		MB28	1.600
M150x2	195	171	24	14	6.0	<b>KM30</b>		MB30	2.030
M160x3	210	182	25	16	7.0	<b>KM32</b>		MB32	2.590
M170x3	220	193	26	16	7.0	<b>KM34</b>		MB34	2.800
M180x3	230	203	27	18	8.0	<b>KM36</b>		MB36	3.070
M190x3	240	214	28	18	8.0	<b>KM38</b>		MB38	3.390
M200x3	250	226	29	18	8.0	<b>KM40</b>		MB40	3.690



# Locking Washers

$d_1 = 10$  to  $200$  mm

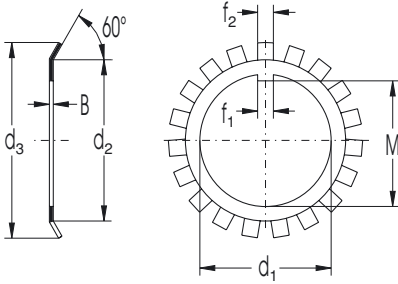

Dimensions							Locking Washer Designation	Weight 100 pcs
$d_1$	$d_2$	$d_3$	$B$	$f_1$	$f_2$	$M$		
mm								kg
10	13.5	21	1.00	3	3	8.5	<b>MB0</b>	0.130
12	17.0	25	1.00	3	3	10.5	<b>MB1</b>	0.200
15	21.0	28	1.00	4	4	13.5	<b>MB2</b>	0.260
17	24.0	32	1.00	4	4	15.5	<b>MB3</b>	0.320
20	26.0	36	1.00	4	4	18.5	<b>MB4</b>	0.350
25	32.0	42	1.25	5	5	23.0	<b>MB5</b>	0.640
30	38.0	49	1.25	5	5	27.5	<b>MB6</b>	0.780
35	44.0	57	1.25	6	5	32.5	<b>MB7</b>	1.040
40	50.0	62	1.25	6	6	37.5	<b>MB8</b>	1.230
45	56.0	69	1.25	6	6	42.5	<b>MB9</b>	1.520
50	61.0	74	1.25	6	6	47.5	<b>MB10</b>	1.600
55	67.0	81	1.50	8	7	52.5	<b>MB11</b>	1.960
60	73.0	86	1.50	8	7	57.5	<b>MB12</b>	2.530
65	79.0	92	1.50	8	7	62.2	<b>MB13</b>	2.900
70	85.0	98	1.50	8	8	66.5	<b>MB14</b>	3.340
75	90.0	104	1.50	8	8	71.5	<b>MB15</b>	3.560
80	95.0	112	1.80	10	8	76.5	<b>MB16</b>	4.640
85	102.0	119	1.80	10	8	81.5	<b>MB17</b>	5.240
90	108.0	126	1.80	10	10	86.5	<b>MB18</b>	6.230
95	113.0	133	1.80	10	10	91.5	<b>MB19</b>	6.700
100	120.0	140	1.80	12	10	96.5	<b>MB20</b>	7.650
105	126.0	145	1.80	12	12	100.5	<b>MB21</b>	8.260
110	133.0	154	1.80	12	12	105.5	<b>MB22</b>	9.400
115	137.0	159	2.00	12	12	110.5	<b>MB23</b>	10.800
120	135.0	148	2.00	14	12	115.0	<b>MBL24</b>	7.000
	138.0	164	2.00	14	12	115.0	<b>MB24</b>	10.500
125	148.0	170	2.00	14	12	120.0	<b>MB25</b>	11.800
130	149.0	175	2.00	14	12	125.0	<b>MB26</b>	11.300
135	160.0	185	2.00	14	14	130.0	<b>MB27</b>	14.400
140	160.0	192	2.00	16	14	135.0	<b>MB28</b>	14.200
150	171.0	205	2.00	16	14	145.0	<b>MB30</b>	15.500
160	182.0	217	2.50	18	16	154.0	<b>MB32</b>	22.200
170	193.0	232	2.50	18	16	164.0	<b>MB34</b>	24.700
180	203.0	242	2.50	20	18	174.0	<b>MB36</b>	16.800
190	214.0	252	2.50	20	18	184.0	<b>MB38</b>	27.800
200	226.0	262	2.50	20	18	194.0	<b>MB40</b>	29.300





# Rolling Elements

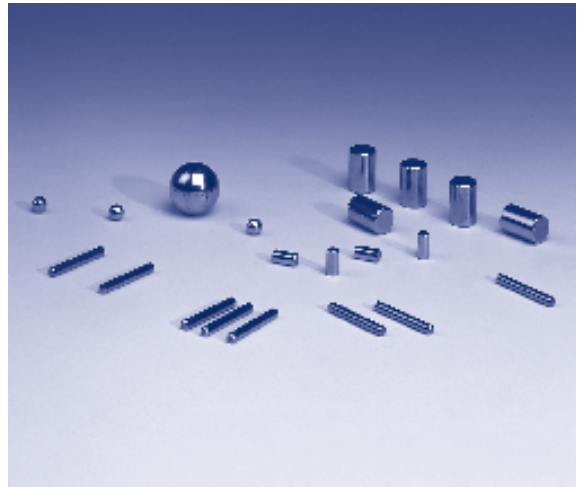

## Balls

Balls as a rolling bearing component are made of the same material as bearing rings. The material hardness after processing (hardening) is 61 to 65 HRC.

Balls with diameter  $D_w = 3.175$  to 17.462 mm are supplied within the tolerance classes 10, 16, 20, 28, 40, and 100. Balls with diameter  $D_w = 18.256$  to 33.338 mm are supplied within the tolerance classes 16, 20, 28, 40 and 100 according to the international standard ISO 3290.

The delivery of balls in different tolerance class or made of a different material should be discussed in advance.

Within each tolerance class, balls of the same nominal diameter  $D_w$  are graded into grades according to mean grading deviation of the nominal ball diameter in the lot  $\Delta D_{wm}$ .

Each grade is packed separately and is marked in documentation and package by the value of the nominal diameter mean deviation in the lot in  $\mu\text{m}$ , e.g.

### Balls 6 - 40 + 4

This means that the ball has the nominal diameter 6 mm, tolerance class 40 and has the actual diameter within 6.003 to 6.005 mm.

Limiting Deviation Diameter and Form. Limiting Surface Roughness.							
Tolerance Class	$D_w$ over	to	$\Delta D_{wm}$	$V_{DwL}$ max	$V_{DwS}$ max	$\Delta$ max	$R_a$ max
	mm		$\mu\text{m}$				
3	0.25	12	$\pm 5$	0.13	0.08	0.08	0.012
5	0.25	12	$\pm 5$	0.25	0.13	0.13	0.020
10	0.25	25	$\pm 9$	0.50	0.25	0.25	0.025
16	0.25	25	$\pm 10$	0.80	0.40	0.40	0.032
20	0.25	38	$\pm 10$	1.00	0.50	0.50	0.040
28	0.25	38	$\pm 12$	1.40	0.70	0.70	0.050
40	0.25	50	$\pm 16$	2.00	1.00	1.00	0.080
100	0.25	120	$\pm 40$	5.00	2.50	2.50	0.125
200	0.25	150	$\pm 60$	10.00	5.00	5.00	0.200

$D_w$  - nominal ball diameter  
 $\Delta D_{wm}$  - limiting deviation of mean ball diameter as individual component  
 $V_{DwL}$  - ball diameter variation in a lot  
 $V_{DwS}$  - individual ball diameter variation  
 $\Delta$  - deviation from roundness /out-of-roundness/  
 $R_a$  - surface roughness



## Cylindrical Rollers

Cylindrical rollers are produced with convex contour of the rolling surface or in design with straight line contour and end crowned towards both faces (ZB).

After being made of rolling bearing steel the cylindrical rollers have hardness 60 to 65 HRC.

Cylindrical rollers are usually delivered in the tolerance class III (DIN 5402). Delivery of rollers made of different dimensions or materials in than dimension tables of the catalogue should be discussed in advance.

Within each tolerance class, the cylindrical rollers of the same nominal diameter  $D_w$  and nominal length  $L_w$  are graded according to the mean grading deviation of the nominal cylindrical roller diameter and length.

Example of cylindrical roller designation is shown in documentation and packing.

### Short cylindrical roller 8 x 12 ZB III + 2/-3

this means that the cylindrical roller has nominal diameter 8 mm and nominal length 12mm in ZB design, tolerance class III and has actual diameter 8.001 to 8.003 mm and actual length 11.994 to 12.000.

Limiting Coordinates of Cylindrical Roller Rounding		
Nominal Diameter $r$	Limiting Dimensions of Rounding Coordinates	
	$r_{s \min}$	$r_{s \max}$
mm	mm	
0.3	0.2	0.5
0.5	0.3	0.8
0.8	0.5	1.2
1.0	0.7	1.5
1.5	1.1	2.1
2.0	1.5	2.7

Limiting Deviations of Dimensions, Form and Position. Limiting Surface Roughness.									
Tolerance Class	$D_w$		$\Delta_{D_{wmp}}$	$V_{DWL}$	$V_{Dwp}$	$\Delta$	$V_{Dwmp}$	Face Convexity	$R_a$
	over	to							
	mm		$\mu\text{m}$						
I.	-	18	+10.25/-16.25	0.5	0.25	0.3	0.3	2	0.08
	18	26	+10.25/-16.25	0.5	0.25	0.4	0.5	2	0.08
II.	-	18	+10.25/-16.25	1.0	0.5	0.5	0.5	2	0.16
	18	26	+10.25/-16.25	1.0	0.5	0.8	1.0	2	0.16
III.	-	18	+11/-17	2.0	1.0	1.0	1.0	2	0.16
	18	26	+11/-17	2.0	1.0	1.5	1.0	2	0.16
IV.	-	18	0/-45	3.0	2.0	2.0	2.0	3	0.32
	18	26	0/-45	3.0	2.0	3.0	2.0	3	0.32

$D_w$  - short cylindrical roller nominal diameter  
 $\Delta_{D_{wmp}}$  - limiting deviation of cylindrical roller diameter as individual component  
 $V_{DWL}$  - variations of cylindrical roller diameter in a lot  
 $V_{Dwp}$  - variation of individual cylindrical roller diameter  
 $\Delta$  - roundness deviation  
 $V_{Dwmp}$  - conicity  
 $R_a$  - cylindrical surface roughness

**Dimension and shape Deviations, except Conicity and Convexity Are Valid in Central Section of Cylindrical Rollers.**

Tolerance Class	$L_w$ over to		$\Delta_{L_{ws}}$	$V_{L_{wL}}$ max	$S_w$ max	Face Convexity max	$R_a$ max
	mm	$\mu\text{m}$					
I.	-	15	+2/-7	3	3	2	0.08
	15	26	+2/-7	3	3	2	0.08
	26	40	+2.5/-7.5	5	5	3	0.08
II.	-	15	+3/-15	6	6	3	0.16
	15	40	+3/-15	6	6	5	0.16
III.	-	26	+10/-20	6	6	3	0.16
	26	40	+10/-20	6	6	5	0.32
IV.	-	10	0/-32	10	16	3	0.63
	10	18	0/-32	10	20	3	0.63
	18	30	0/-32	15	25	5	0.63
	30	40	0/-50	20	30	5	0.63

- $L_w$  - Short cylindrical roller nominal length
- $\Delta_{L_{ws}}$  - limiting length deviations of rollers as individual components
- $V_{L_{wL}}$  - roller length variation in a lot
- $S_w$  - lateral run-out
- $R_a$  - face surface roughness





# Cylindrical Rollers

$D_w = 22$  to 53 mm

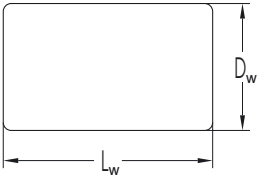

Dimensions			Dimensions			Dimensions		
$D_w \times L_w$	r	Weight 100 pcs	$D_w \times L_w$	r	Weight 100 pcs	$D_w \times L_w$	r	Weight 100 pcs
mm		kg	mm		kg	mm		kg
22x34	1.0	10.000	38x38	2.0	33.300			
22x44	1.0	12.900	38x62	2.0	55.000			
22x48	1.0	14.200						
			40x40	2.0	38.900			
23x23	1.0	7.400						
23x34	1.0	11.200	42x42	2.0	45.400			
24x24	1.0	8.400	45x45	2.0	55.800			
24x26	1.0	9.100						
24x36	1.0	12.600	48x48	2.0	67.700			
24x40	1.0	14.100	48x52	2.0	73.700			
24x52	1.0	18.100						
			53x53	2.0	91.000			
25x25	1.5	9.500						
25x36	1.5	13.700						
26x26	1.5	10.700						
26x40	1.5	16.400						
26x48	1.5	19.800						
26x55	1.5	22.600						
27x48	1.5	21.400						
28x28	1.5	13.300						
28x30	1.5	14.300						
28x32	1.5	15.300						
28x44	1.5	21.000						
28x56	1.5	26.900						
30x30	1.5	16.300						
30x33	1.5	18.000						
30x48	1.5	26.200						
30x63	1.5	34.600						
32x32	1.5	19.900						
32x52	1.5	32.400						
32x64	1.5	40.000						
34x34	2.0	23.900						
34x55	2.0	38.700						



# Special Rolling Bearings

In addition to standard and modified bearings shown in this catalogue, special rolling bearings are also made. As a rule, they have non-standard dimensions and cannot be involved in the standard types, they are made of different materials and are determined for usage in machines or equipment arrangements whose design does not allow standard bearings.

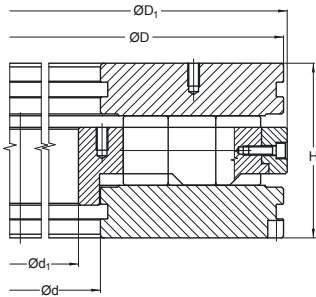

PLC 912-86

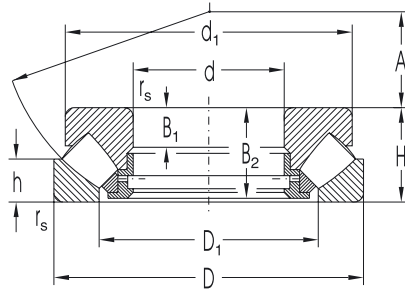

PLC 912-85

## Special Thrust Roller Bearing

Dimensions					Basic Load Rating		Fatigue load limit	Weight	Bearing Designation
d	d1	D	D1	H	Dynamic $C_r$	Static $C_{or}$	$P_u$	~	
mm					kN		kN	kg	
860	812	1260	1268	190,8	10260	70630	4 242,13	942	<b>PLC 912-86</b>
540	890	980	717	250	12180	51000	3 384,64	787	<b>PLC 912-85</b>

## Double Row Spherical Roller Bearings Single Row Deep Groove Ball Bearing

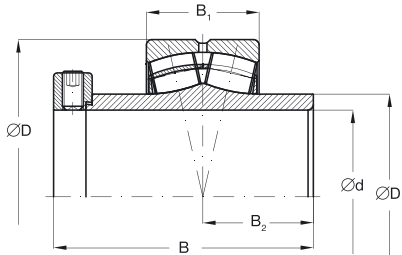

PLC 58-11

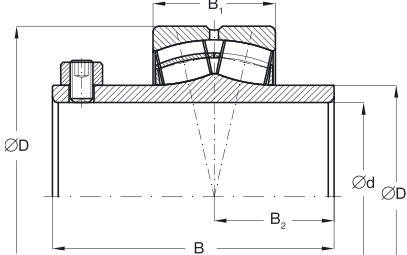

PLC 58-9-1

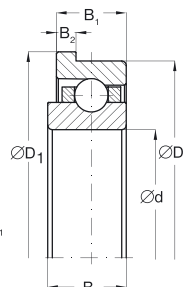

PLC 010-3

Dimensions						Basic Load Rating		Fatigue load limit	Weight	Bearing Designation
d	D	D <sub>1</sub>	B <sub>1</sub>	B <sub>2</sub>	B	Dynamic $C_r$	Static $C_{or}$	$P_u$	~	
mm						kN			kg	
74.6	120	88.34	31.0	31.8	92.0	196	255	31.10	3.0	<b>PLC 58-11</b>
76.2	130	88.71	31.0	31.8	92.2	196	255	30.81	3.1	<b>PLC 58-9-1</b>
140.0	215	225.00	38.1	10.7	42.9	116	139	4.74	5.3	<b>PLC 010-3</b>



# Double Row Spherical Roller Bearings Single Row Cylindrical Roller Bearings

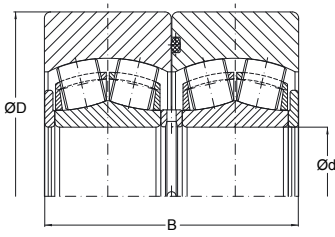

PLC 58-12

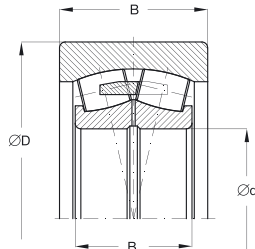

PLC 511-14

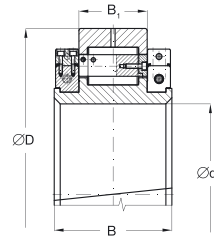

PLC 412-27-1, PLC 412-27,  
PLC 412-7, PLC 412-7-1, PLC 412-8

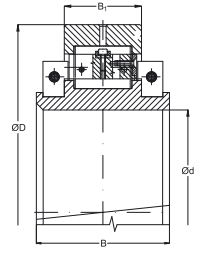

PLC 412-11

Dimensions				Basic Load Rating		Fatigue load limit $P_u$	Weight ~ kg	Bearing Designation
d	D	$B_1$	B	Dynamic $C_r$	Static $C_{or}$			
mm				kN		kN	kg	
60	160,00	-	110,0	467	629	74,55	12,4	<b>PLC 58-12</b>
110	288,92	80,0	115,9	786	978	96,95	40,0	<b>PLC 511-14</b> <sup>1)</sup>
218	393,76	90,5	156,0	1200	1760	45,74	83,8	<b>PLC 411-27-1</b> <sup>2)</sup>
220	393,76	90,5	156,0	1200	1760	45,67	83,0	<b>PLC 411-27</b> <sup>2)</sup>
240	440,07	90,5	156,0	1248	1920	47,33	92,0	<b>PLC 412-7</b> <sup>2)</sup>
238	440,07	90,5	156,0	1248	1920	47,40	92,0	<b>PLC 412-7-1</b> <sup>2)</sup>
260	431,8	96,8	170	1140	1940	47,41	86,5	<b>PLC 412-11</b>
320	622,37	160,4	272,0	3100	4950	103,65	353,0	<b>PLC 412-8</b> <sup>2)</sup>

1) Truck Roller.  
2) Split cylindrical roller bearing for rolling mills.

# Double Row Spherical Roller Bearing Single Row Deep Groove Ball Bearing

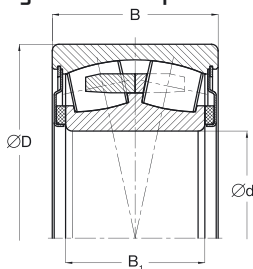

PLC 58-2

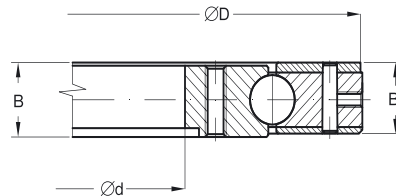

KL 761

Dimensions				Basic Load Rating		Fatigue load limit $P_u$	Weight ~ kg	Bearing Designation
d	D	$B_1$	B	Dynamic $C_r$	Static $C_{or}$			
mm				kN		kN	kg	
65	158.8	48.0	70.0	212	250	29.48	7.36	<b>PLC 58-2</b>
559	761.0	36.5	38.2	232	425	7.52	51.30	<b>KL 761</b> <sup>1)</sup>

1) Single row ball bearing for peeling machines in wood-processing industry.



## Double Row Spherical Roller Bearings

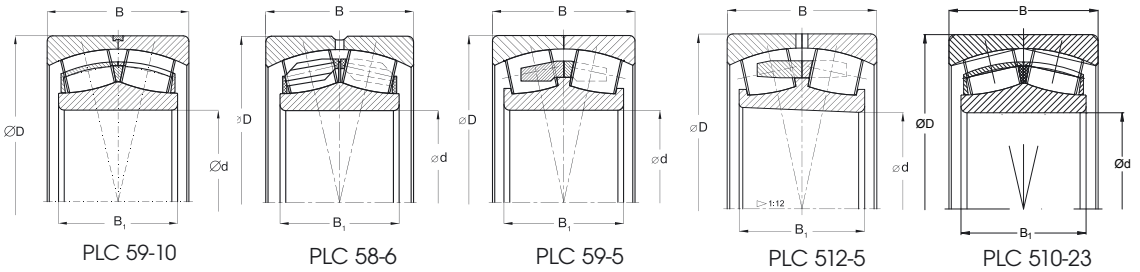

Dimensions				Basic Load Rating		Fatigue load limit $P_u$	Weight ~	Bearing Designation
d	D	$B_1$	B	Dynamic $C_r$	Static $C_{or}$			
mm				kN		kN	kg	
100	150,00	62,00	50,0	310	550	62,73	3,7	<b>PLC 58-6</b> <sup>1)</sup>
100	180,00	69,00	82,0	480	710	78,27	10,3	<b>PLC 59-5</b> <sup>2)</sup>
110	180,00	69,00	82,0	501	839	91,52	7,7	<b>PLC 59-10</b> <sup>4)</sup>
120	215,00	76,00	98,0	678	1020	106,56	13,5	<b>PLC 510-23</b> <sup>1)</sup>
440	720,00	226,00	270,0	4300	9000	647,74	389,0	<b>PLC 512-5</b> <sup>3)</sup>

1) Double row spherical roller bearing with plastic cage and increased angle of misalignment up to 7° for gearbox of mobile concrete mixer.  
 2) Double row spherical roller bearing with increased angle of misalignment up to 7° for gearbox of mobile concrete mixer.  
 3) Double row spherical roller bearing with split and extended outer ring and increased angle of misalignment up to 7°.  
 4) Bearing with extended outer ring for angle of misalignment up to 6°

## Double Row Spherical Roller Bearings Single Row Cylindrical Bearing

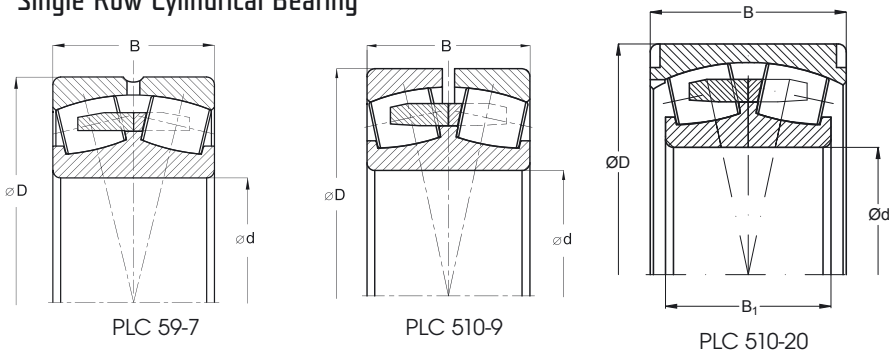

Dimensions				Basic Load Rating		Fatigue load limit $P_u$	Weight ~	Bearing Designation
d	D	$B_1$	B	Dynamic $C_r$	Static $C_{or}$			
111,6	215	90	76	564	803	84,53	14,4	<b>PLC 510-20</b>
130	220	73	76	570	1080	111,35	12,2	<b>PLC 59-7</b> <sup>1)</sup>
130	225	80	76	570	1080	110,88	12,2	<b>PLC 510-9</b>
750,0	920	68	76	3100	8000	516,14	89,9	<b>PLC 412-12</b>

1) Double row spherical roller bearing according to dimensional plan UIC for axleboxes of railway vehicles with journal diameter 130 mm.

# Double Row Spherical Roller Bearings

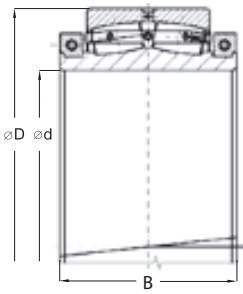

PLC 512-37

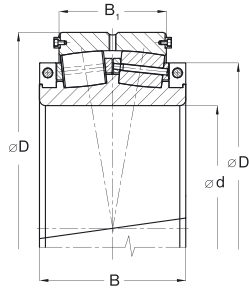

PLC 512-39

Dimensions					Basic Load Rating		Fatigue load limit	Weight	Bearing Designation
d	D	D <sub>1</sub>	B	B <sub>1</sub>	Dynamic C <sub>r</sub>	Static C <sub>0r</sub>	P <sub>u</sub>	~	
mm					kN		kN	kg	
750	1000	—	360	—	6380	17230	1096.15	1220	PLC 512-37 <sup>1)</sup>
670	1150	—	500	345	12960	23450	1 474,40	1710	PLC 512-39 <sup>2)</sup>

1) Double row spherical roller bearing with split outer ring for arrangement of bucket excavator journal.  
2) Split double row spherical roller bearing for arrangement of steel converter.

# Single Row Deep Groove Ball Bearings

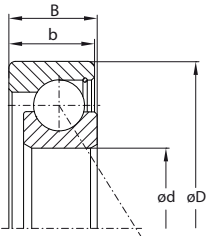

PLC 03-29

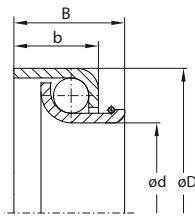

PLC 03-33

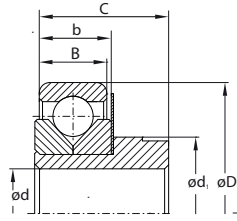

PLC 03-79

Dimensions			Basic Load Rating		Fatigue load limit	Limiting Speed for Lubrication with Grease Oil		Weight	Bearing Designation
d	D	B	Dynamic C <sub>r</sub>	Static C <sub>0r</sub>	P <sub>u</sub>			~	
mm			kN		kN	min <sup>-1</sup>		kg	
17.0	35.0	9.0	8.20	5.30	0.24	18000	21000	0.033	PLC 03-29
22.2	36.9	16.5	5.11	6.31	0.29	1) <sup>1)</sup>		0.034	PLC 03-33
10.4	35.0	10.0	4.82	1.36	0.06	12600	17000	0.069	PLC 03-79

1) Steering column



## Thrust Ball Bearings

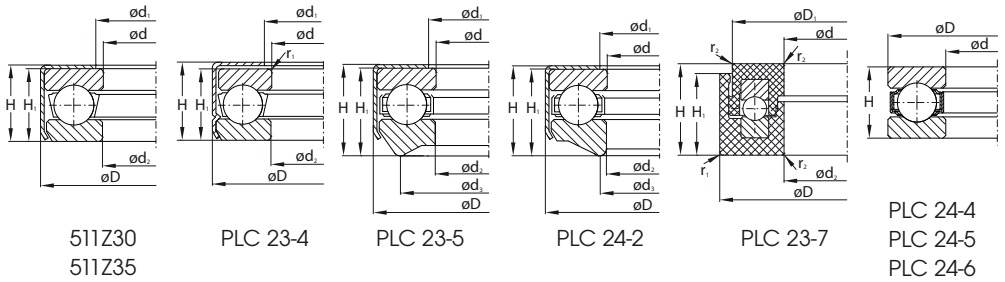

Dimensions			Basic Load Rating		Fatigue load limit $P_u$	Limiting Speed for Lubrication with		Weight ~	Bearing Designation	Dimensions				
d	D	B	Dynamic $C_a$	Static $C_{oa}$		Grease	Oil			$d_1$	$d_2$	$d_3$	$H_1$	$r_{1,2}$
mm			kN		kN	$\text{min}^{-1}$		kg		mm				
30.0	49.2	12.0	18.8	31.6	1.44	4200	-	0.086	<b>511Z30</b>	36.0	30.2	-	11.0	0.6
	49.2	12.0	17.4	28.2	1.28	4200	-	0.083	<b>PLC 23-4</b>	36.0	30.8	-	11.0	0.6
	49.2	13.6	17.4	28.2	1.28	4200	-	0.085	<b>PLC 23-5</b>	36.0	30.8	40	12.5	0.6
35.0	53.6	12.8	20.0	38.3	1.74	4000	-	0.093	<b>511Z35</b>	38.0	37.0	-	12.0	0.6
	53.6	15.5	20.0	38.3	1.74	3500	-	0.111	<b>PLC 24-2</b>	38.0	37.0	40	14.7	0.6
17.0	35.0	12.3	9.6	15.5	0.70	1)		0.029	<b>PLC 23-7</b>	17.2	32.4	-	10.4	0.5
45.2	65.0	10.8	27.8	57.5	2.61	3800	5000	0.100	<b>PLC 24-4</b>	-	-	-	-	-
40.1	59.9	10.8	26.9	51.2	2.33	3800	5000	0.090	<b>PLC 24-5</b>	-	-	-	-	-
55.2	78.0	11.6	34.8	78.4	3.56	3200	4200	0.150	<b>PLC 25-6</b>	-	-	-	-	-

1) The bearing is intended for pendulum motion or low frequency rotation.

## Double Row Ball Bearings

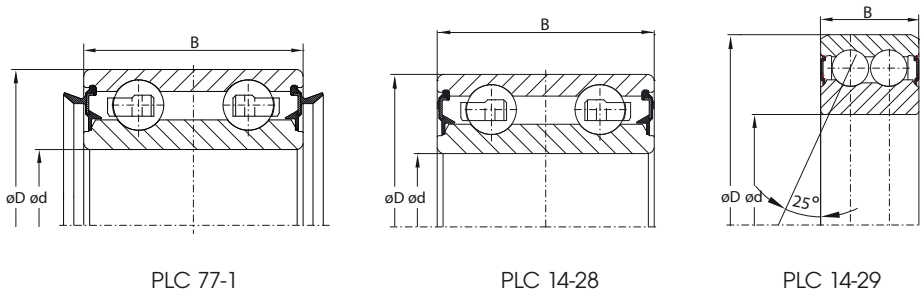

Dimensions			Basic Load Rating		Fatigue load limit $P_u$	Limiting Speed for Lubrication with		Weight ~	Bearing Designation
d	D	B	Dynamic $C_r$	Static $C_{or}$		Grease	Oil		
mm			kN		kN	$\text{min}^{-1}$		kg	
25	52	43.8	24.3	17.7	0.80	5250	-	0.301	<b>PLC 77-1</b>
	52	37.0	24.3	17.7	0.80	5250	-	0.301	<b>PLC 14-28</b>
36	62	16.0	24.1	27.1	1.23	4410	-	0.192	<b>PLC 14-29</b>

# Double Row Angular Contact Ball Bearings

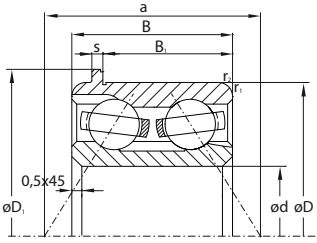

PLC 15-2<sup>1)</sup>

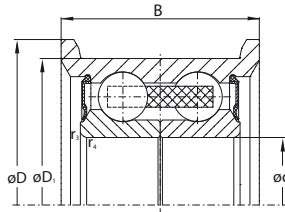

PLC 14-26

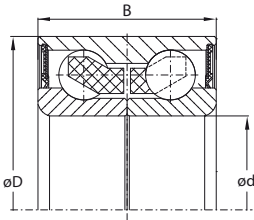

PLC 14-25  
PLC 14-24  
PLC 15-22

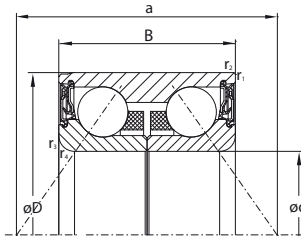

PLC 15-12<sup>2)</sup>

Dimensions			Basic Load Rating		Fatigue load limit $P_u$	Limiting Speed for Lubrication with		Weight ~	Bearing Designation	Dimensions						
d	D	B	Dynamic $C_r$	Static $C_{or}$		Grease	Oil			d	$D_1$	$B_1$	s	$r_{1,2}$ min	$r_{3,4}$ min	a
mm			kN		kN	$\text{min}^{-1}$		kg		mm						
25	65.5	25.4	30.4	26.6	1.21	7100	8400	0.466	<b>PLC 15-2<sup>1)</sup></b>	25	74	16.5	4.4	1.1	-	40.0
	55.0	20.0	19.2	15.5	0.70	8500	10000	0.280	<b>PLC 14-26</b>	25	62	28.0	-	-	1.0	26.8
30	60.0	37.0	36.9	30.4	1.38	7000	8300	0.450	<b>PLC 14-25</b>	30	-	-	-	2.5	0.5	50.5
34	64.0	37.0	36.9	31.0	1.41	6300	7500	0.320	<b>PLC 14-24</b>	34	-	-	-	2.8	0.3	53.3
35	68.0	37.0	39.8	38.3	1.74	6500	-	0.534	<b>PLC 15-12<sup>2)</sup></b>	35	-	-	-	2.5	0.3	50.5
37	72.0	37.0	43.8	39.8	1.81	5000	6000	0.550	<b>PLC 15-22</b>	37	-	-	-	2.8	0.3	57.0

1) The bearing has pressed steel cage that is guided on the balls. Bearing are originally intended for shaft arrangement in gear boxes of motor vehicles.

2) The bearing has cage made of reinforced polyamide that is guided on the balls, special seal rings on both sides and is filled with grease.



## Single Row Cylindrical Roller Bearings for Railway Vehicle Axles

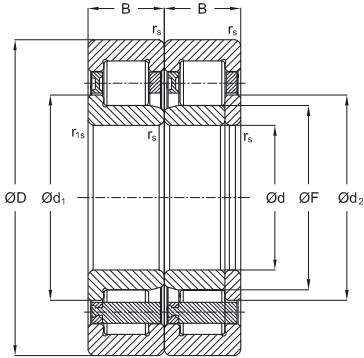

Bearing Designation	Dimensions							Basic Load Rating		Fatigue load limit $P_u$	Maximum Speed of Rail Vehicle	Radial Clearance		Axial Clearance		Weight ~	Precision Class
	d	D	B	$r_{smin}$	$r_{1smin}$	$d_1$	$d_2$	F	$C_r$			$C_{or}$	min.	max.	min.		
	mm							kN			$km \cdot h^{-1}$	mm		mm		kg	
<b>PLC 410-13</b>	120	240	80	3	7.5	160.8	150	553	742	75.86	160	0.120	0.16	0.3	0.9	16.8	P0
<b>PLC 410-13-2</b>	120	240	80	3	7.5	160.8	150	553	742	75.86	160	0.120	0.16	0.3	0.9	16.0	P0
<b>PLC 410-14</b>	120	240	80	3	7.5	160.8	150	553	742	75.86	160	0.120	0.16	0.3	0.9	16.8	P0
<b>PLC 410-14-2</b>	120	240	80	3	7.5	160.8	150	553	742	75.86	160	0.120	0.16	0.3	0.9	16.0	P0
<b>PLC 410-15</b>	130	240	80	3	7.5	170.5	159	517	752	76.25	160	0.135	0.18	0.3	0.9	15.2	P0
<b>PLC 410-15-2</b>	130	240	80	3	7.5	170.5	159	517	752	76.25	160	0.135	0.18	0.3	0.9	14.5	P0
<b>PLC 410-16</b>	130	240	80	3	7.5	170.5	159	517	752	76.25	160	0.135	0.18	0.3	0.9	15.2	P0
<b>PLC 410-16-2</b>	130	240	80	3	7.5	170.5	159	517	752	76.25	160	0.135	0.18	0.3	0.9	14.5	P0
<b>PLC 410-33-2</b>	130	240	80	3	7.5	170.5	157	540	775	78.58	200	0.135	0.18	0.3	0.9	15.1	P6
<b>PLC 410-34-2</b>	130	240	80	3	7.5	170.5	157	540	775	78.58	200	0.135	0.18	0.3	0.9	15.1	P6

Bearings correspond to the requirements of international standards ISO, EN and UIC.

Used for axle arrangements of passenger cars and wagons, motor coaches and locomotives. Bearings have a solid brass cage centered on cylindrical rollers, or on the ribs of the outer ring (in this case the cage has lubrication grooves). Inner rings and semi - units are mutually interchangeable.

# Bearing Units

## Double Row Ball Bearings for Textile Machines and Instrument Technics

Bearings for textile machines are designed for high speed and relatively low load, i.e. they have high dimension and operation accuracy, which secures their high utilization value and operating reliability. Bearings create a nonseparable unit consisting of a shaft and a cylindrical bush arranged in a rotary way on two rows of balls. Light one - side cages made of plastic are centered on rolling elements. Raceways on the shaft and in the bush are made in the high tolerance class. Against impurity penetration there are effective contact or non-contact sealing on both sides. Bearings are filled with grease which secures effective lubrication usually during the whole bearing life. In some cases the bearings are adapted for re-lubrication. The bearing creates a complex arrangement unit enabling simple mounting and service. Bearings for instrument technics have also high dimension and operation accuracy and work as a rule at lower speed than bearings in textile machines.

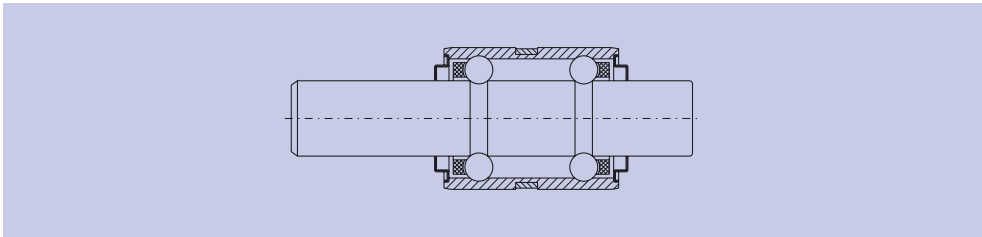

## Double Row Bearings for Water Pumps of Combustion Motors

Bearings for water pumps of combustion motors create an inseparable unit consisting of a shaft and a cylindrical bush arranged in two rows of balls or in one row of balls and one row of cylindrical rollers. Balls or cylindrical rollers are arranged in light one-side plastic cages. Raceways on the shaft and in the cylindrical bush are made in high tolerance class. Against impurity penetration there is an effective contact sealing on both sides. Bearings are filled with grease which secures effective lubrication during the whole bearing life. The bearing creates a complex arrangement unit enabling simple mounting and service.

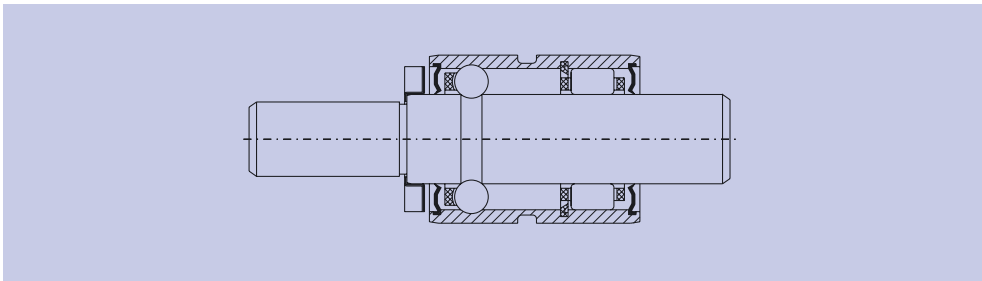

## Bottom Bracket Bearings for Bicycles

Bottom bracket bearings for bicycles create an inseparable unit consisting of a steel case -hardened or hardened shaft and a cylindrical bush made of bearing steel or of AL- alloy or also of polyamide filled with glass fibre. Raceways for two rows of balls are created by grinding directly on the shaft and in the cylindrical bush. Balls are arranged in one - side light cages made of plastic. Against impurity penetration there is a rubber contact sealing on both sides. Bearings are filled with grease which secures effective lubrication during the whole bearing life.

The advantage of these bearings is that they do not demand any maintenance and when mouting no clearance adjustment is necessary as for classical arrangements, because the optimum clearance is set directly by the bearing manufacturer.



For bearing clamping into the bicycle frame hub dishes made of galvanized steel or plastic are used. Ring dish creates one unit with the double row ball bearing, left dish is independent and supports the bearing only radially. By this design the bearing compact can be universally utilized for bicycles with various frame hub length in the range 66 to 71 mm.

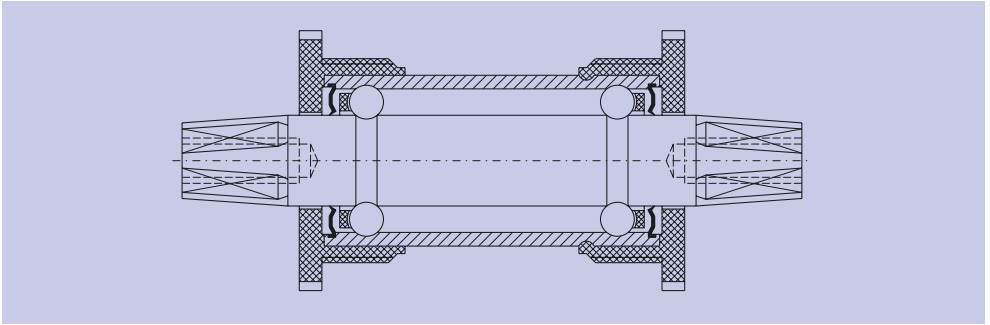

## Survey of Further Special Rolling Bearings

### Single Row Ball Bearings

For industrial needs, especially for automobile, aircraft industries and industries dealing with production of transportation equipment the bearings shown in the picture below have been developed and are being manufactured.

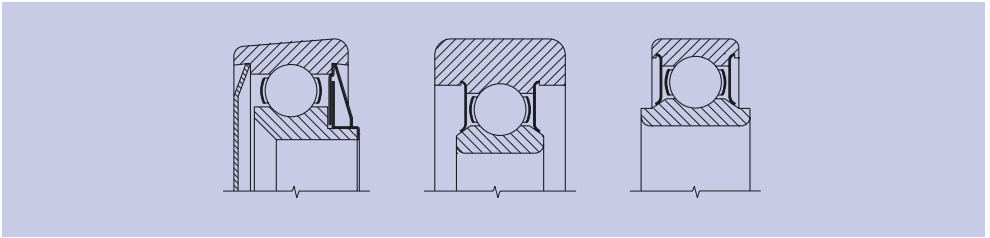

### Clutch Bearings

Used in automobile industry for clutches of passenger cars and trucks.

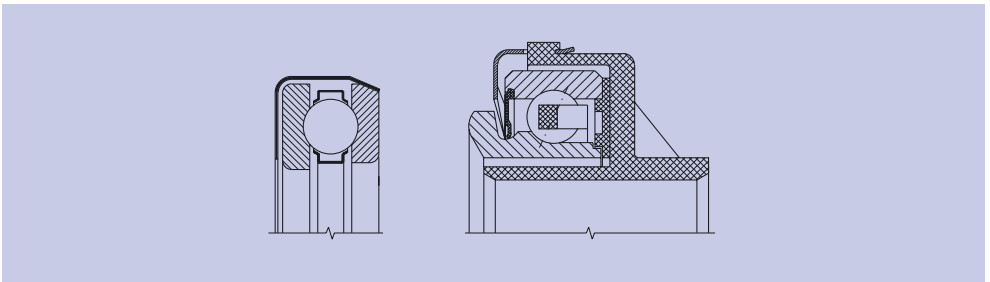



## Single Row Cylindrical Roller Bearings

Used in automobile and aircraft industries.

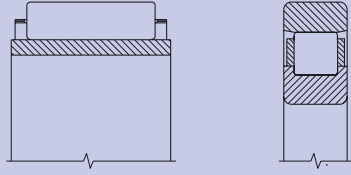

## Multi-Row Cylindrical Roller Bearings

Used for accommodation of especially great radial forces with limited space, especially in metallurgy, for arrangement of rolling mill rollers. These bearings have rings with lubricating holes so that access of lubricant into all cylindrical roller rows can be secured.

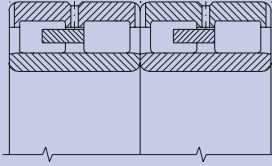

## Single Row and Double Row Tapered Roller Bearings

Used prevalingly in automobile industry and in the area of heavy mechanical engineering.

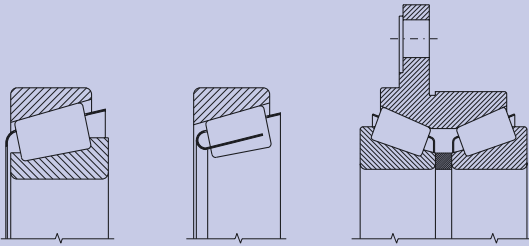

## Double Row Tapered Roller Bearings

Used for arrangements of rolling mill rollers and other equipments in steel rolling mills.

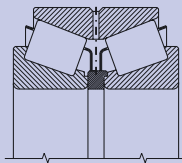

## Slewing Rings with Crossed Rollers

Slewing rings with crossed rollers in standard design are compact double - ring bearings with cross arrangement of cylindrical rollers in the raceway between inner and outer ring. Cylindrical rollers are in most cases split by separators made of plastic, or by a compact or segment cage. Contact angle of the raceways is usually  $45^\circ$ . Bearings are delivered with clearance or preload, it depends on their utilization. Bearing rings have holes for fixing screws. Inner space is protected by seals against excessive grease leakage from bearing and penetration of macro - impurities into the bearing.

They are produced with outer diameter from 300 to 2500 mm, with internal or external gear, or without gear for arrangements of construction and earth machines, robots and manipulators, machine tools, cutter loaders, rotating shields, wind-power plants, and rotational furnaces.

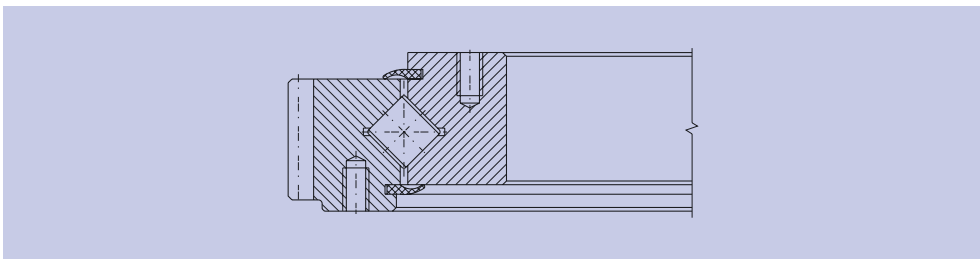

## Slewing Ring with Balls

Bearings are suitable for both durably rotating equipments and for machines with a cyclical character of work having medium size e.g. excavators and cranes. For higher rotational speed bearings with compact or segment cage are produced. They have relatively low friction moment. Arrangement rigidity with the use of ball bearings is lower than by crossed roller bearings. Their contact angle is usually  $45^\circ$ .

They are produced with outer diameter from 300 to 2650mm with internal or external gear, or without gear.

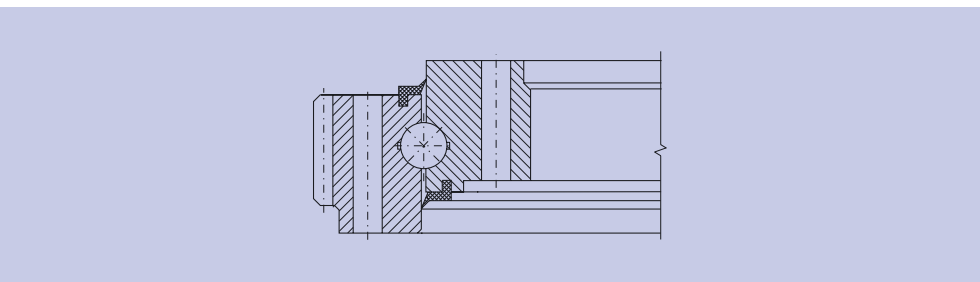

## Double Direction Cylindrical Roller and Tapered Roller Thrust Bearings

Used for accommodation of great axial forces in rolling mill roller arrangements and also where great rigidity in axial direction is required, mainly in arrangement of vertical lathe tables.

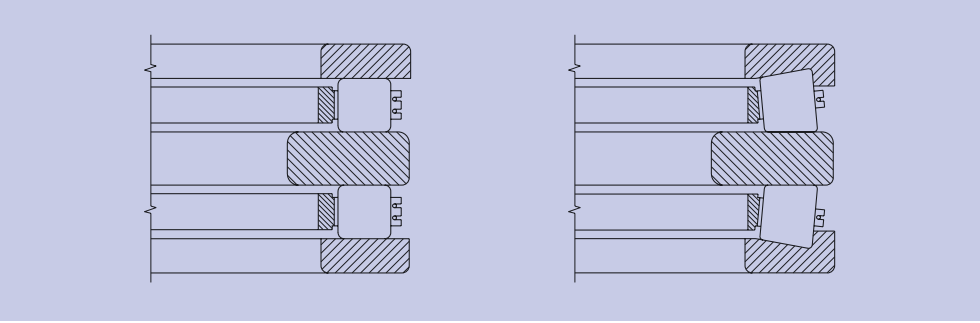

More precise information concerning special bearings can be obtained in firms' publications.

**More information at**  
[www.zkl.cz](http://www.zkl.cz)



# Rolling Bearings

Publ. No. ZKL 3/11/ENG





### **ZKL, a.s.**

Jedovnická 8, Brno  
Czech Republic, Europe  
Phone: +420 544 135 120  
E-mail: head@zkl.cz



### **ZKL Bearings CZ, a.s.**

Holečkova 31, Praha  
Czech Republic, Europe  
Phone: +420 257 311 203  
E-mail: zkl@zkl.cz

# **WWW.ZKL.EU**