



ویرا پرداز آروین پاسارگاد

با مدیریت خانم مهندس احمدی



جهت مشاوره

با کارشناسان فنی

با ما در ارتباط باشید



021 - 91001377



0935 125 90 98

# D.I.D.<sup>®</sup>

Factory:  
**DAIDO KOGYO CO., LTD.**  
1-197, Kumasaka-Cho, Kaga-City, Ishikawa Pref, 922-8686, Japan

Sales & Marketing:  
**D.I.D CO., LTD.**  
**Head Office (Tokyo Office)**  
3-5-4 Ningyo-cho, Nihonbashi Chuo-ku Tokyo 103-0013, Japan  
Phone +81-3-3808-0785 Fax +81-3-5695-7146  
**Osaka Office**  
2-12-12 Minami-semba, Chuo-ku Osaka 542-0081, Japan  
Phone +81-6-6251-2027 Fax +81-6-6258-3230

Distributed by \_\_\_\_\_

Note) To consistently improve our products, the specifications in this catalog are subject to change without notice.



© D.I.D CO.,LTD. JAN.2007 071A03-B  
Printed in Japan

**D.I.D** GENERAL CATALOG **2007** DAIDO KOGYO CO.,LTD.

# D.I.D.<sup>®</sup>



# GENERAL CATALOG

POWER TRANSMISSION & CONVEYOR CHAIN  
**ALL PRODUCTS GUIDE**



# 2007



## **DRIVEN TO SOLUTIONS**

### **The D.I.D Brand**

Known for its Durability and Dependability in Design.

An established technical innovator in the world chain drive market,  
serving a broad spectrum of industries with quality products

for over 70 years. That is D.I.D

Our technology turns timely ideas into productive realities.

D.I.D a professional partnership you can count on

for your optimum drive system solutions.

**DID is a brand you can depend on.**

# Certified Management System in Conformity with World Standards

Quality assurance and environmental management system authorized by domestic and overseas standards.

## DID's Quality Assurance

- Customer satisfaction is our priority.
- All DAIDO members are committed to quality.
- Quality control based on facts is assured.

With activities based on these quality policies, our quality assurance system is internationally authorized to state that our products conform to the ISO9000 series and API.

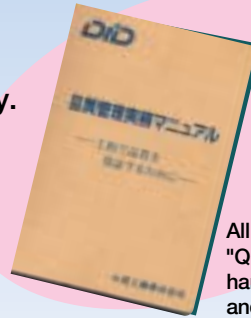

All of our employees keep a copy of our "Quality Control Practice Manual" at hand as their bible of quality control and refer to it during routine activities.

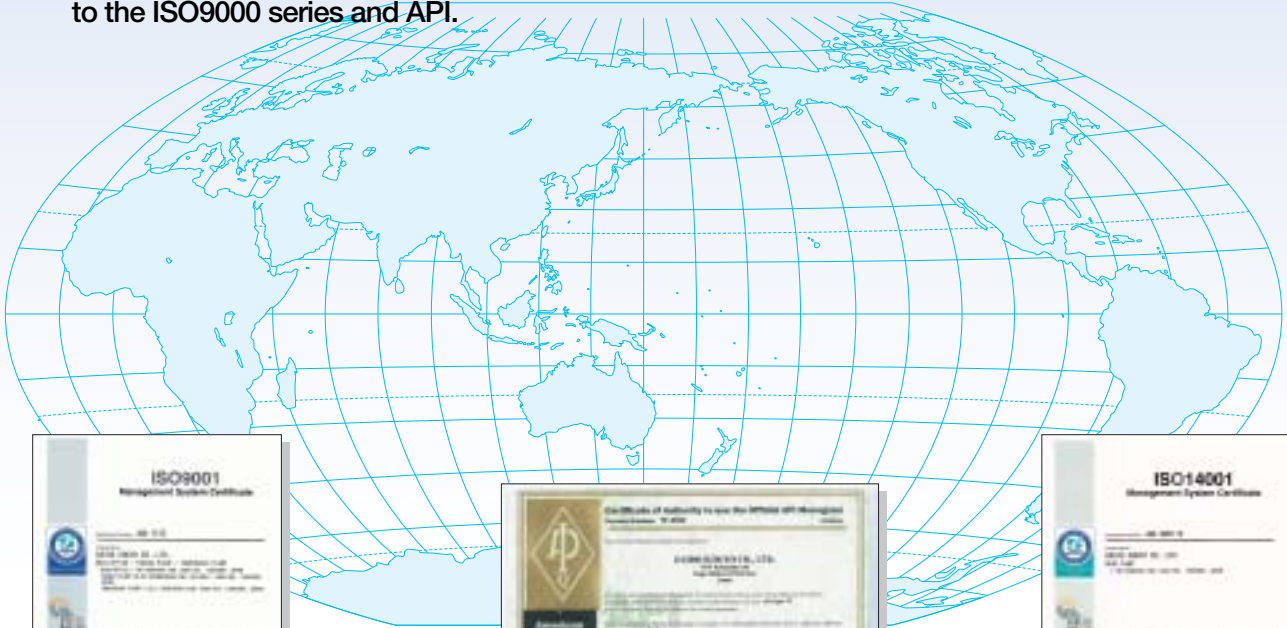

### ISO9001/2000 Certification

It is indispensable to obtain the certification of ISO9001/2000 for supplying products to overseas markets - not only Europe and the US but also other countries. Our entire production system, including design, development, manufacturing, installation and technical assistance for all of our products including various chains, conveyor systems and welfare equipment, has been certified by the Japan Quality Assurance Organization (JQA).

### Authorization by API

The American oil industry applies rigid quality control standards to all mechanical parts used in oil field development and oil refining. The organization that examines the conformity with their standards for authorization is called API (American Petroleum Institute). Since receiving authorization from API in 1972, we have been supplying DID roller chains and sprockets to many companies not only in the USA but also all over the world under our rigid quality control system.

### ISO14001 Certification

ISO14001 was established in 1996 by the International Organization for Standardization, to set requirements for environmental management systems. In order to preserve the global environment, reverse contamination and enhance the health of human beings and ecosystems, DAIDO declared our policies for environmental preservation. As a result, our management system for our activities, products and service for environmental protection was certified by the organization. We have been engaged in various activities for environmental preservation and improvement, such as reduction of waste and classification of waste for recycling, in accordance with our environmental policies.





For safe use of DID products

**CAUTION**

**Before use, be sure to read  
the catalog and instruction manual carefully.  
If you find something unclear,  
please consult with us.**

# Cautions

## Cautions for handling of chains and sprockets

Before handling chains and sprockets, please understand the respective structures and specifications correctly, and read the following cautions for using them safely.

### 1 Handling of chains and sprockets

#### For safe work



- Always wear clothes suitable for work and proper protection (safety glasses, safety shoes, etc.).
- In addition to site workers, other people near the work site are also required to be careful.
- Strictly observe Section 1 "General Standards" (prevention of danger by prime movers, revolution shafts, etc.), Chapter 1, Part 2 of Occupational Safety and Health Regulations.
- For working, keep things in order in and around the work site.
- Before installation, be sure to switch off the power.  
Before installing, removing, lubricating or otherwise servicing a chain and sprockets, be sure the main electric power switch and all secondary power switches of the equipment are turned off. Also, take precaution to ensure that power will not be switched on accidentally. Furthermore, exercise care to prevent clothing or any part of the body from being caught by a chain, sprocket or other part during work.
- When any lifting apparatus is used, never stand beneath it.

#### Handling

- For handling (See P127 ~ 137 and P329 ~ 342.)
- For handling, follow the instructions in this catalog and in the instruction manual. Select, layout, install, adjust and maintain chains and sprockets in the way that is recommended to ensure a high-performance installation.
  - When connecting a chain, employ an installation method suitable for the type of connecting link.
  - For the layout, installation, adjustment and maintenance, observe both recommended equipment instructions and cautions.

#### Warning



- Do not partially replace a part of a chain. Do not partially exchange a worn or damaged chain and sprockets. Replacing only the worn or damaged part does not restore overall strength and risks further breaking or destruction. Always replace the entire chain and sprockets.
- Do not modify chains or sprockets. Most of the components of a chain are heat-treated. If they are reprocessed, strength is diminished and breaking or destruction can result.
- Electroplating may cause hydrogen embrittlement.
- Welding may lower the strength of chains and components due to a flaw or heat, and result in destruction.
- Annealing can lower the performance of products and components and may result in destruction.

### 2 Chain Installation

#### Connection

- (1) Before installation, please read the previous section (1).
  - (2) Use connecting links and offset links as described below.  
When installing a connecting link or offset link, confirm its construction. (P17)
- For installing the clip on the connecting link, refer to the method illustrated below.

Chain clip installation method

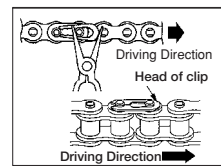

- For installing a cotter pin on the connecting link, refer to the method illustrated below.

Cotter pin installation method

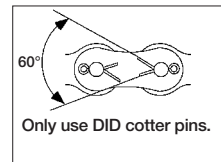
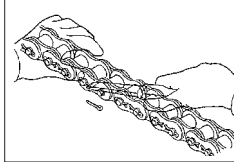

- For installing a spring pin, refer to the method illustrated below. Spring pins are used for interference-fitted connecting links used in DIDHI-PWR-S, HK and HI-PWR-SHK series (P50 ~ 59, P60 ~ 61, P62 ~ 63).

Spring pin installation method for HI-PWR-S series

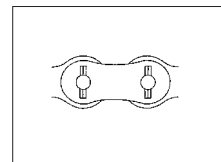
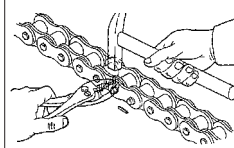

- For installing a T-pin or S-pin, refer to the method illustrated below.

T-pin or S-pin installation method

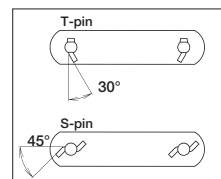
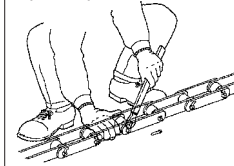

- For installing a one-pitch offset link, follow the installation method for the cotter pin type connecting link, and for installing a two-pitch offset link, follow the installation method of the connecting link used.

For other special types of connecting links, please consult us.

**Warning**

- Do not attempt to modify any components. When assembling, never drill a hole on a connecting plate to make it larger and never file a pin to make it thinner for smooth insertion of the pin into the connecting plate.
- Do not use used chains. Do not reuse clips and do not install a used cotter pin, connecting link or any other component for a new chain.

**Adjustment**

- (3) For proper operation of a chain, install and adjust it correctly. (See P127 ~ 134 and P340 ~ 342.)

**Confirmation**

- (4) After installing a chain and sprockets, confirm the following before switching on the power:
- Is the connecting link correctly and securely connected?
  - Is the chain engaged with the teeth of the sprockets?
  - Is the amount of lubrication proper?
  - Is anything likely to cause interference or be scattered?
  - Is the safety cover correctly installed?
  - Is there anything interfering with the safety cover?
  - Whether or not there is anything interfering with the chain.
  - If there is anything abnormal about the connecting link portion, etc. and whether the respective components of the chain are flawed, rusty or abnormal in any other way.
  - Do not stay in the rotation direction of the chain.
- (5) If any abnormal noise is generated after switching on the power, switch off the power and re-confirm.

**Avoidance of Danger**

- Install a safety cover. For the apparatus with a chain and sprockets installed, be sure to install a safety cover. Any unexpected fracture may cause the chain to be thrown from the sprockets. In addition to a sufficient protector, install a stopping device such as an overload limit switch or brake so as not to cause overload.
- Check for chain interference. Any obstacle which interferes with a driven chain and sprockets is dangerous and shortens the life of the chain and sprockets. Always check for any interfering objects, and remove them.

## 3 Maintenance

To prevent any serious accident caused by a chain and sprockets, and to prolong the life of the chain and sprockets, take the following maintenance actions:

**Lubrication**

- (1) Lubrication (See P.132 ~ 134 and P.342.) Except for some chains of special materials or elements, most chain life can be prolonged with lubrication. A chain which requires lubrication will be shortened in life without lubrication. For example, chain elongation, corrosion and stiff joint occur due to wear of some chain parts.

**Washing**

- (2) Washing If a chain is used with a material such as sand or metallic powder, the promotion of wear, stiff joint, etc. will be caused, shortening life. Wash away such harmful materials.

For washing, dip the chain into kerosene, dry, and sufficiently lubricate. However, in the case of O-ring chain, since the O-ring may be deteriorated by kerosene, do not dip it for more than 10 minutes.

For washing, do not use an acid, alkali, gasoline or highly volatile solvent detrimental to the chain and sprockets. For an O-ring chain, do not use a wire brush.

**Adjustment**

- (3) Adjustment of tension and timing of exchange (See P130 ~ 131, P137 and P341 ~342.)

Chains and sprockets are consumable products.

The wear of a chain and sprockets causes sag on the chain. Periodically check the chain for sag, and adjust the tension to the optimum condition.

If a chain and sprockets show any rust or harmful flaw in appearance, or if the elongation of a chain or the wear of a sprocket becomes critical, immediately replace them.



- Do not use an offset link for lifting.
- Excessive oil on the chain will cause fouling by scattering. Wipe off extra oil to prevent it from scattering.
- For washing, do not use gasoline or highly volatile solvent. Furthermore, do not allow any material containing acid or alkali to come in contact with it.

## 4 Others

Even chains of the same kind and size have a different service life depending on the service environment, numbers of teeth of the sprockets, lubrication and other conditions. This also applies to the life of sprockets. Chains and sprockets are different in wear life. If a new chain is used on an old sprocket with worn teeth, failure or rupture of the chain may occur.

When a chain or sprocket must be replaced, replace both the chain and sprockets.

If anything remains unclear, please consult us.

## Cautions for using roller chains for lifting

Based on the "Chain Safety (Technical) Standards" and "End Fittings" proposed by Japan Chain Association to the Japan Parking System Manufacturers Association Incorporated and multilevel parking machine manufacturers in February and October, 1993, the cautions necessary for using roller chains (hereinafter called chains) for lifting are stated below.

### 1 Safety factor

The "Mechanical Parking Area Technical Standard" sets the safety factors of ropes and chains as "5 for system A", "7 for system B" and "10 for system C". However, if a chain is used at a safety factor of 5 in system A, the acting tension of the chain generally exceeds the Max. allowable tension of the chain. That is, repeated use causes the chain to rupture due to fatigue. Therefore, when a safety factor of 5 for system A is adopted, periodically replace the chain under strict life control.

### 2 Selection of chain

#### 2-1 Max. tension

The Max. tension allowed to apply to a chain is set at not higher than the value obtained by dividing the minimum tensile strength of the chain by a safety factor. However, be sure to examine the selecting methods recommended by us (See P120 and 121), and adopt a safer method.

The Max. tension corresponds to the "corrected chain tension" which includes dynamic load at starting and stopping in addition to offset load by a motor vehicle (difference in weight between front and rear wheels, horizontal shift of the motor vehicle in reference to a pallet, offset load due to the chain lifting position, etc.)

#### 2-2 Connecting link of chain

A general connecting link (R type and C type in this catalog) has pins clearance-fitted in the connecting plate holes.

The connecting link is lower in fatigue strength than the base chain. When a connecting link higher in fatigue strength is necessary, use a special connecting link with pins interference-fitted connecting plate holes (F type or H type in this catalog).

In this case do not use any offset link (OJ or 2POJ). As for the types of connecting links, see P16 ~ P17.

### 3 Connection between a chain and an end fitting

The connection between a chain and an end fitting (hereinafter called a fitting) is the section likely to cause troubles. For safety purposes, take the following matters into account when you design.

#### 3-1 General cautions

- (1) If the dimensional difference between the inner width of an outer link of a chain and the width of a fitting or the dimensional difference between the pin diameter and the fitting hole is too large, a large bending stress acts to lower the pin strength dramatically.  
Refer to "3-3 Dimensions of fitting" for your design.
- (2) If the fitting hole suffers "wear" or "roll over" at its ends during use, the strength of the pin greatly declines as in the case of (1). Periodically check, and if "wear" or "roll over" is found in the fitting hole, replace the fitting.
- (3) Rust or corrosion is the major cause of deterioration of strength. Apply grease to chains periodically to prevent rust.
- (4) If a partial load, lateral load or torsional load acts on a chain, the strength of the chain declines. To prevent it, exercise sufficient care in the horizontality of fitting of the hole, installation accuracy of fitting, etc.

#### 3-2 Material of fitting and heat treatment

- (1) Hardened fitting  
The fitting is generally hardened and tempered. Thoroughly examine the size and material hardness of the fitting, and select a material which ensures a sufficient hardness.
  - a. In general, select a material which ensures the required hardness from tough hardening steels (SCM435, SCM440, etc.) and medium carbon steel.
  - b. Harden the fitting, and temper at a high temperature, avoiding the temper brittleness range, to a hardness of about HRC30 to 45.
  - c. In the case of a threaded fitting, keep the hardness at not higher than HRC40, to lower the susceptibility of the threaded portion to delayed fracture.  
Select the size of the threaded portion to achieve a tensile strength not lower than the tensile strength of the chain.
- (2) Non-hardened fitting  
If the fitting is used without being hardened and tempered, the following must be considered.
  - a. Since the fitting hole is likely to suffer from wearing during use, press a hard bushing into the fitting hole.
  - b. Since the strength of the fitting is lower than that of a hardened and tempered fitting,

adequate strength must be secured by adopting corresponding dimensions.

### 3-3 Dimensions of fitting

Dimensions of general hardened fittings for standard roller chains are listed below. For the fittings of more than triple strand chains and fittings of other shapes, please consult us. When

designing an end fitting for any chain other than standard roller chains, work out a safe design based on sufficient understanding of this section. If there is anything unclear, please consult us.

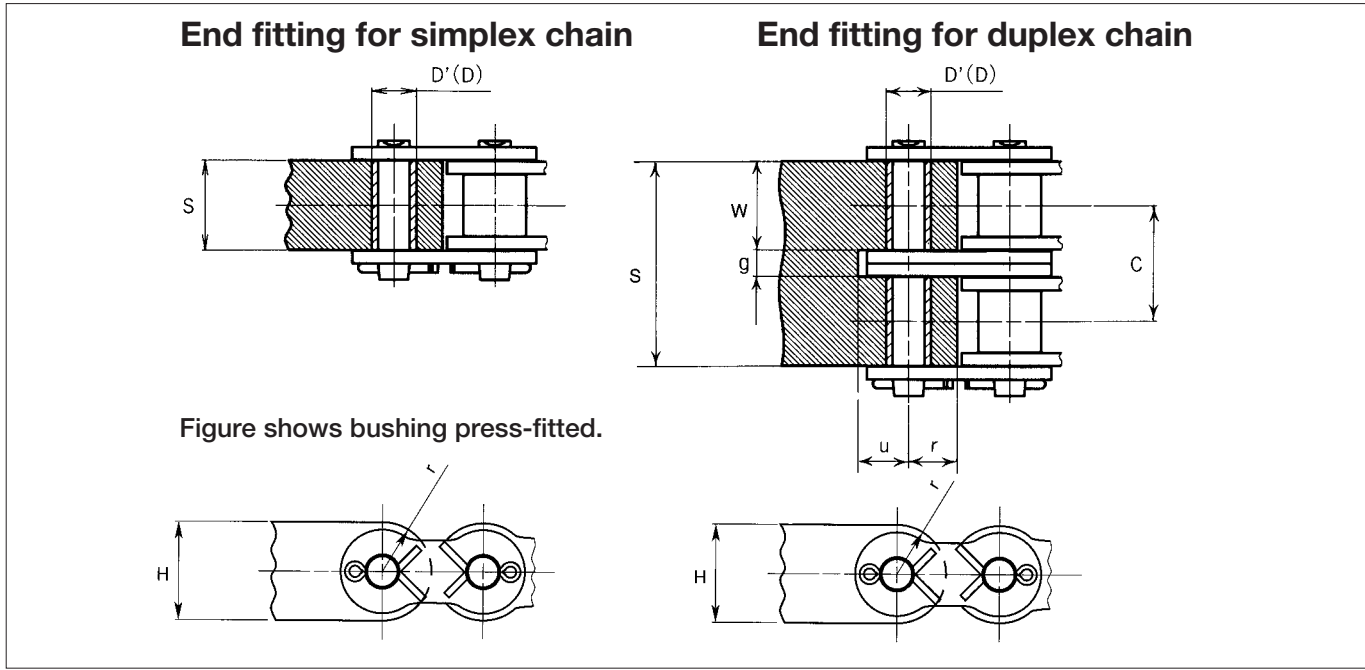

### Dimensions of End fitting

Unit (mm)

Chain No.	g	W (Reference)	S	D (Without Bushing)	D' (With Bushing)	C	r (Reference)	u (Reference)	H (Reference)
<b>DID 35-1</b>	—	—	7.5 <sup>-0.2</sup>	3.62 <sup>+0.05</sup>	5.02 <sup>±0.02</sup>	—	4.5	—	9.0
<b>DID 35-2</b>	2.8 <sup>+0.1</sup>	7.2~ 7.4	17.5 <sup>-0.3</sup>			10.1 <sup>±0.1</sup>		4.7	
<b>DID 40-1</b>	—	—	11.2 <sup>-0.2</sup>	4.00 <sup>+0.05</sup>	5.58 <sup>±0.02</sup>	—	6.0	—	12.0
<b>DID 40-2</b>	3.2 <sup>+0.1</sup>	10.9~ 11.1	25.4 <sup>-0.3</sup>			14.4 <sup>±0.1</sup>		6.3	
<b>DID 50-1</b>	—	—	13.8 <sup>-0.2</sup>	5.12 <sup>+0.05</sup>	7.16 <sup>±0.02</sup>	—	7.5	—	15.0
<b>DID 50-2</b>	4.3 <sup>+0.1</sup>	13.6~ 13.8	31.9 <sup>-0.3</sup>			18.1 <sup>±0.1</sup>		7.9	
<b>DID 60-1</b>	—	—	17.8 <sup>-0.2</sup>	5.99 <sup>+0.05</sup>	8.40 <sup>±0.02</sup>	—	9.2	—	18.1
<b>DID 60-2</b>	5.2 <sup>+0.1</sup>	17.4~ 17.7	40.4 <sup>-0.3</sup>			22.8 <sup>±0.1</sup>		9.5	
<b>DID 80-1</b>	—	—	22.6 <sup>-0.2</sup>	7.97 <sup>+0.1</sup>	11.27 <sup>±0.02</sup>	—	12.2	—	24.2
<b>DID 80-2</b>	6.8 <sup>+0.1</sup>	22.3~ 22.6	51.8 <sup>-0.3</sup>			29.3 <sup>±0.1</sup>		12.7	
<b>DID 100-1</b>	—	—	27.5 <sup>-0.3</sup>	9.57 <sup>+0.1</sup>	13.47 <sup>±0.02</sup>	—	15.2	—	30.2
<b>DID 100-2</b>	8.5 <sup>+0.1</sup>	27.1~ 27.4	63.1 <sup>-0.3</sup>			35.8 <sup>±0.1</sup>		15.8	
<b>DID 120-1</b>	—	—	35.5 <sup>-0.3</sup>	11.15 <sup>+0.1</sup>	15.64 <sup>±0.02</sup>	—	18.2	—	36.2
<b>DID 120-2</b>	10.1 <sup>+0.1</sup>	35.1~ 35.4	80.7 <sup>-0.3</sup>			45.4 <sup>±0.1</sup>		19.0	
<b>DID 140-1</b>	—	—	37.2 <sup>-0.3</sup>	12.75 <sup>+0.1</sup>	17.94 <sup>±0.02</sup>	—	21.2	—	42.3
<b>DID 140-2</b>	12.0 <sup>+0.1</sup>	36.7~ 37.0	85.8 <sup>-0.3</sup>			48.9 <sup>±0.1</sup>		22.2	
<b>DID 160-1</b>	—	—	45.2 <sup>-0.3</sup>	14.33 <sup>+0.1</sup>	19.94 <sup>±0.02</sup>	—	24.2	—	48.3
<b>DID 160-2</b>	13.6 <sup>+0.1</sup>	44.7~ 45.0	103.4 <sup>-0.3</sup>			58.5 <sup>±0.1</sup>		25.4	

Note:

- 1) The dimensions of D' can be applied only when DID bushings are used. If these dimensions are applied to the bushings for chains produced by other manufacturers, the strength may be lower.
- 2) Dimensions "g" and "S" of duplex chain chain with bushings include the dimensions of the bushings.



## 1 Roller Chains for Power Transmission

General	16
Standard Roller Chain	18
Ultimate Power Chain Series	
Strong chains suitable for use in various conditions	48
HI-PWR-S Type Roller Chains	50
HK Type Roller Chains	60
HI-PWR-SHK Type Roller Chains	62
Ultimate Life Chain Series	
Dependable in severe conditions	64
Wide range of product line-up	66
Solid Bushing Chain (HT/D), (D)	68
DH- $\alpha$ Chain (DHA)	70
O-Ring Chain (LD)/X-Ring Chain (LX)	72
Sintered Bushing Roller Chain (UR/ URN)	74
Environment Resistant Chain Series	
Applicable for many different environments	80
Nickel Plated Chain (N)	82
Hi-Guard Chain (E)	84
Double Guard Chain (WG)	86
Stainless Steel Chain (SS/SSK)	88
Stainless Steel X-Ring Chain	90
Low-Temperature Resistant Chain (TK)	92
Low Noise Chain Series	
Unparalleled noise reduction	94
Super Low Noise Chain (UN)	96
Specialty Chain Series	
Responding to various kind of needs	98
Bicycle Chain	101
Small Pitch Chain	102
Engine Mechanism Chain	103
Silent Chain	104
Agricultural Roller Chain	106
BS Roller Chain (British Standard Roller Chain)	107
Leaf Chain	108
Related Products	
Roller Chain Coupling	110
DID C-Top (Chain Cover)	114
Sprocket	115
Designing of Chain Transmission	
How to Select the Proper Chain	120
Chain Selection by Temperature	124
Chain Length and Sprocket Center Distance	125
Layout	126
Maintenance	
Installation	127
Maintenance	130
Lubrication	132
Troubleshooting Guide	134
Timing for Replacement	137

## 2 Small Conveyor Chains

General	140
Single Pitch Chain	
Standard Conveyor Chain with Attachments Series (Single Pitch)	142
Standard Attachments	144
Standard Roller Chain	146
Long Life Chain (T), (D)	148
DH- $\alpha$ (DHA) Chain	150
O-Ring/ X-Ring Chains (LX), (LD), (LXN), (LDN)	152
Sintered Bushing	154
Rustless Chain	156
High Guard Chain	158
Double Guard Chain	160
Stainless Steel Chain	162
Stainless Steel X-Ring Chain	164
Low Temperature Resistant Chain	166
Double Pitch Chain	
Conveyor Chain with Standard Attachments Series (Double Pitch)	168
Double Pitch Chain and Sprockets	170
Sprockets for Double Pitch Chain	172
Standard Attachments	174
Standard Roller Chain	176
Long Life Chain	178
DH- $\alpha$ Chain	180
O-ring Chain	182
Sintered Bushing Roller Chain	184

Rustless Chain	186
High Guard Chain	188
Double Guard Chain	190
Stainless Steel Chain	192
Stainless Steel X-Ring Chain	194

### Free Flow Chains and Other Conveyor Chains

DID Free Flow Chains and Other Conveyor Chains	196
Single Pitch Top Roller Chain	198
Double Pitch Top Roller Chain	200
Overturn Prevention Type Top Roller Chain	202
Top Roller Chain Overturn Prevention Series (Double Pitch)	203
Side Roller Chain	204
Side Roller Chain Series (Double Pitch)	204
Side Roller Chain Meandering Prevention Series (Double Pitch)	205
Free Flow Chain with Breaks	206
Hollow Pin Chain	208
Flexible Chain	209
Flat Type Roller Chain	210

### Technical Information

Calculation of Chain Tension	212
Strength of Loaded Components	215
Inquiry Sheet	216

## 3 Conveyor Chains

### Outline of Conveyor Chains

Classification	218
Construction and Components of DK Conveyor Chains	219
How to Order DK Conveyor Chains	220

### Standard Conveyor Chain

Variation of DK Regular Conveyor Chain	221
Roller Type	222
Classified by Material and Heat Treatment	223
Classification by Surface Treatment	224
Chain Specifications	225
Dimensional Drawings (for Metric series)	DK03 — 226
	DK07 — 227
	DK09 — 228
	DK11 — 229
	DK13 — 230
	DK19 — 231
	DK25 — 232
	DK32 — 233
	DK50 — 234
	DK65 — 235
Dimensional Drawings (for Inch series)	DK05 — 236
	DK08 — 237
	DK09 — 238
	DK11 — 239
	DK13 — 240
	DK19 — 241
	DK25 — 242

### Anti-seizing Roller Conveyor Chain

Anti-seizing Roller Conveyor Chain	243
Dimensional Drawings (for Metric series)	DK03 — 244
	DK07 — 245
	DK09 — 246
	DK11 — 247
	DK13 — 248
	DK19 — 249
	DK25 — 250
	DK32 — 251
	DK50 — 252
	DK65 — 253
Dimensional Drawings (for Inch series)	DK05 — 254
	DK08 — 255
	DK09 — 256
	DK11 — 257
	DK13 — 258
	DK19 — 259
	DK25 — 260

### Bearing Assembled Roller Conveyor Chain

Bearing Assembled Roller Conveyor Chain	261
Dimensional Drawings (for Metric series)	DK11 — 262
	DK13 — 263
	DK19 — 264
	DK25 — 265
	DK32 — 266
	DK50 — 267
Dimensional Drawings (for Inch series)	DK11 — 268
	DK19 — 269
	DK25 — 270

<b>Seal Chain</b>	
Seal Chains	271
Dimensional Drawings (Seal Chains)	272
<b>Strong H-type and Z-type Conveyor Chain</b>	
Strong H-type and Z-type Conveyor Chain	273
Dimensional Drawings (Strong H-type Conveyor Chain)	274
Dimensional Drawings (Strong Z-type Conveyor Chain)	275
<b>High Link-Plate Chain</b>	
Conveyor Chain with Side Roller	278
Conveyor Chain with Top Roller	279

## 4 DK Specialty Conveyor Chains

<b>Conveyor Chain Exclusive for Specific Conveyance</b>	
Conveyor Chain with Attachments for Conveying Bulk Materials	280
Continuous Flow Conveyor Chain	281
Shapes and Indications of Attachments	282
Chains for Dust Conveyor	283
Block Chains type dust conveyor	284
Eco Slight	285
Chain for Garbage Conveyor	286
NE Bucket Elevator Chains	287
NSE Bucket Elevator Chains	288
Flat Top Type Chain for Coil Conveyor	289
Long Pan Conveyor Chain	290
Block Chain	291
Special Rivetless Chain	292
<b>Water Treatment Conveyor Chain</b>	
Chains for Traveling Water Screen	293
Rake Chain	294
Sewage Treatment Chain (WS or WAS Type Chain)	295
Attachment	296
WAS Type Bush Chain	297
BF Type Bushing Chain for Water Treatment Drive Unit	298
<b>3D Bending Conveyor Chain</b>	
X Type Chains for Trolleys, and Power & Free Conveyors	299
Z-type Chain for Light Load Trolley Conveyors	300
FH Type Chain for Freeyor	301
Towline Low-Selec-Tow Chain	302
Booster Chain for Rivetless Chain	303
<b>Others</b>	
Draw Bench Chain	304
Chain Bearing Roller	305
Access Window (Dr. WINDOW)	306

## 5 Photo / Sprocket

Photos of Conveyor Systems and Chains in Use	308
Photos of Specialty Chains	313
DK Conveyor Chain Sprocket	314

## 6 Technical Information

Chain Selection	330
Allowable Loads of Rollers and Attachments	337
Property of Loads and Recommended Chains	338
Corrosion Resistance Against Various Substances	339
Rust Prevention of DK Conveyor Chain	340
Installation, Adjustment and Maintenance	341
Installation of Sprockets, Conveyor Chain Connection Procedure	341
Tension Adjustment of Conveyor Chain	342
Lubrication, Service limit of conveyor chain	343
Inquiry Sheet	344
Glossary	345

## Keys and Symbols



**Dirty or contaminated lubricants or deterioration of lubrication.**



**Corrosive atmosphere**  
(by CAS test).



**Sandy or dusty environment.**



**Atmosphere where exposure to rain, moisture, and sea water is present.**



**Where lubrication is infrequent or prohibited.**



**Atmosphere where alkaline liquid is present.**



**Great cost savings can be achieved through longer life and less down time.**



**Atmosphere where acid liquid is present.**



**Index of tensile strength**  
(Standard chain is the base line).



**Atmosphere where cleanliness is required.**



**Temperature range in use.**



**Coating tolerable temperature**



**Allowable tension index**  
(Standard roller chains)



As conveyor chain in vending machine.



As conveyor and drive chain in packing machine.



As conveyor and drive chain in conveyance machine.



As conveyor and drive chain in chemical processing equipment.



As drive chain in vertical automated parking.



As conveyor and drive chain in outdoor equipment.



As conveyor and drive chain in book binding machine.



As conveyor and drive chain in textile machine.



As conveyor and drive chain in food processing machine.



As conveyor and drive chain in printing machine.



As conveyor and drive chain in water treatment.



As drive chain in construction machine.



# Index (In alphabetical order)

Product No.	Description	Page
DEC [ ] - [ ]	Eco Slight (Small Sized Apron Conveyor Chain)	285
DID 1/2X [ ]	Bicycle Chain	101
DID [ ]	Engine Mechanism Chain	103
DID [ ]	Small Pitch Chain	102
DID [ ]	Agricultural Machine Chain	106
DID [ ] B	BS Roller Chain (ANSI-B Type)	107
DID [ ] BF, DID [ ] BFH	BF Bushing Chain	298
DID [ ] DHA	DH- $\alpha$ Chain	70 • 150 • 180
DID [ ] E	Hi-Guard Chain	84 • 158 • 188
DID [ ] F	Flat Plate Type Roller Chain	210
DID [ ] FX	Flexible Chain	209
DID [ ] HK	HK Roller Chain	60~61
DID [ ] HP	Hollow Pin Chain	208
DID [ ] LD, DID [ ] LX	O-Ring/X-Ring Chain	72 • 152 • 182
DID [ ] N	Nickel Plated Chain	82 • 156 • 186
DID [ ] -SR- [ ]	Side Roller Chain	204
DID [ ] -SRB- [ ]	Side Roller Chain with Brake	207
DID [ ] SS	Stainless Steel Chain	88 • 162 • 192
DID [ ] SSK	Stainless Steel Chain	88 • 162 • 192
DID [ ] SSLT	Stainless Steel X-Ring Chain	90 • 164 • 194
DID [ ] T, DID [ ] D	Solid Bushing Chain	68 • 148 • 178
DID [ ] TK	Low-Temperature Resistance Chain	92 • 166
DID [ ] -TR- [ ]	Top Roller Chain	198
DID [ ] -TRB- [ ]	Top Roller Chain with Brake	206
DID [ ] UN	Super Low Noise Chain	96
DID [ ] UR	Sintered bushing roller chain	74 • 154 • 184
DID [ ] URN	Sintered bushing roller chain (Plated)	74 • 154 • 184
DID [ ] WG	Double Guard chain	86 • 160 • 190
DID [ ] -A,B,BW,C	Double Pitch Chain Sprocket	172
DID [ ] -A,B,BW,C	DID Roller Chain Sprocket	19~47 • 115
DID AL [ ]	AL Leaf Chain	108
DID BL [ ]	BL Leaf Chain	108
DID C [ ]	Double Pitch Chain	168
DID C- [ ]	Roller Chain Coupling	110
DID CT- [ ]	DID C-TOP (Chain Cover)	114
DID HI-PWR-S [ ]	HI-PWR-S Roller Chain	50
DID HI-PWR-S [ ] HK	HI-PWR-S HK Roller Chain	62
DID PS- [ ] DHA	PS Silent Chain	105
DID SC- [ ] SDH	SC Silent Chain	104
DID SCA- [ ] SDH	SCA Silent Chain	104
DID SCR- [ ] SDH	SCR Silent Chain	104
DK [ ]	NE Bucket Elevator Chain	287
DK [ ]	NSE Bucket Elevator Chain	288
DK [ ]	Apron Conveyor Chain	285
DK [ ]	Continuous Flow Conveyor Chain	281
DK [ ]	Chain for Dust Conveyor	283
DK [ ]	Replacement Sprocket Tooth	328
DK [ ]	Rake Chain	294

Product No.	Description	Page
DK [ ] - [ ]	Long Pan Conveyor Chain	290
DK [ ] BR,DK [ ] BF	Bearing Roller Conveyor Chain	261~270
DK [ ] UF	Chain for Garbage Conveyor	286
DK [ ] UR,DK [ ] UF	Anti-seizing Roller Conveyor Chain	243~260
DK [ ] H [ ]	DK strong H Conveyor chain	274
DK [ ] Z [ ]	DK strong Z Conveyor Chain	275~276
DK [ ] -A,B,BW,C	DK Conveyor Chain Sprocket	314
DK [ ] B [ ]	Block Chain	291
DK [ ] -SR	Conveyor Chain with Side Roller	278
DK [ ] -TR	Conveyor Chain with Top Roller	279
DK [ ] V	Seal Chain	272
DK [ ] -A- [ ]	DK Standard Conveyor Chain: Standard	223 • 226~242
DK [ ] -C- [ ]	DK Standard Conveyor Chain: Wear Resistant	223
DK [ ] -D- [ ]	DK Standard Conveyor Chain: Wear Resistant	223
DK [ ] -D1- [ ]	DK Standard Conveyor chain	223
DK [ ] -D2- [ ]	DK Standard Conveyor chain	223
DK [ ] -D3- [ ]	DK Standard Conveyor chain	223
DK [ ] -D4- [ ]	DK Standard Conveyor chain	223
DK [ ] -D5- [ ]	DK Standard Conveyor chain	223
DK [ ] -D6- [ ]	DK Standard Conveyor chain	223
DK [ ] -E- [ ]	DK Standard Conveyor chain	223
DK [ ] -K- [ ]	DK Standard Conveyor chain	223 • 226~242
DK [ ] -P- [ ]	DK Standard Conveyor chain	223
DK [ ] -S3- [ ]	DK Standard Conveyor chain	223
DK [ ] -S4- [ ]	DK Standard Conveyor chain	223
DK [ ] -S5- [ ]	DK Standard Conveyor chain	223
DK [ ] -SH- [ ]	DK Standard Conveyor chain	223
DK 100-152	Special Rivetless Chain	292
DK CBR [ ]	Chain Bearing Roller	305
DK FH- [ ]	FH Chain for Versatile Uses	301
DK L..S.T 6	Towline Low-selec-tow Chain	302
DK WAS [ ]	WAS Busing Chain	297
DK WS [ ]	WS Roller Chain	295
DK X [ ]	X-type Chains for Trolley, Power & Free Conveyors	299
DK Z- [ ]	Z-type Chain for Light Load Trolley Conveyor	300
DK-BU X [ ]	Booster Chain for Rivetless Chain	303
DK-HL [ ]	High Link Chain	277
IW [ ] ,IWH [ ] ,IWD [ ]	Access Window (Dr. WINDOW)	306
	Check Gauge	114
	Chain Lube	114
	HI-PWR Lube	114

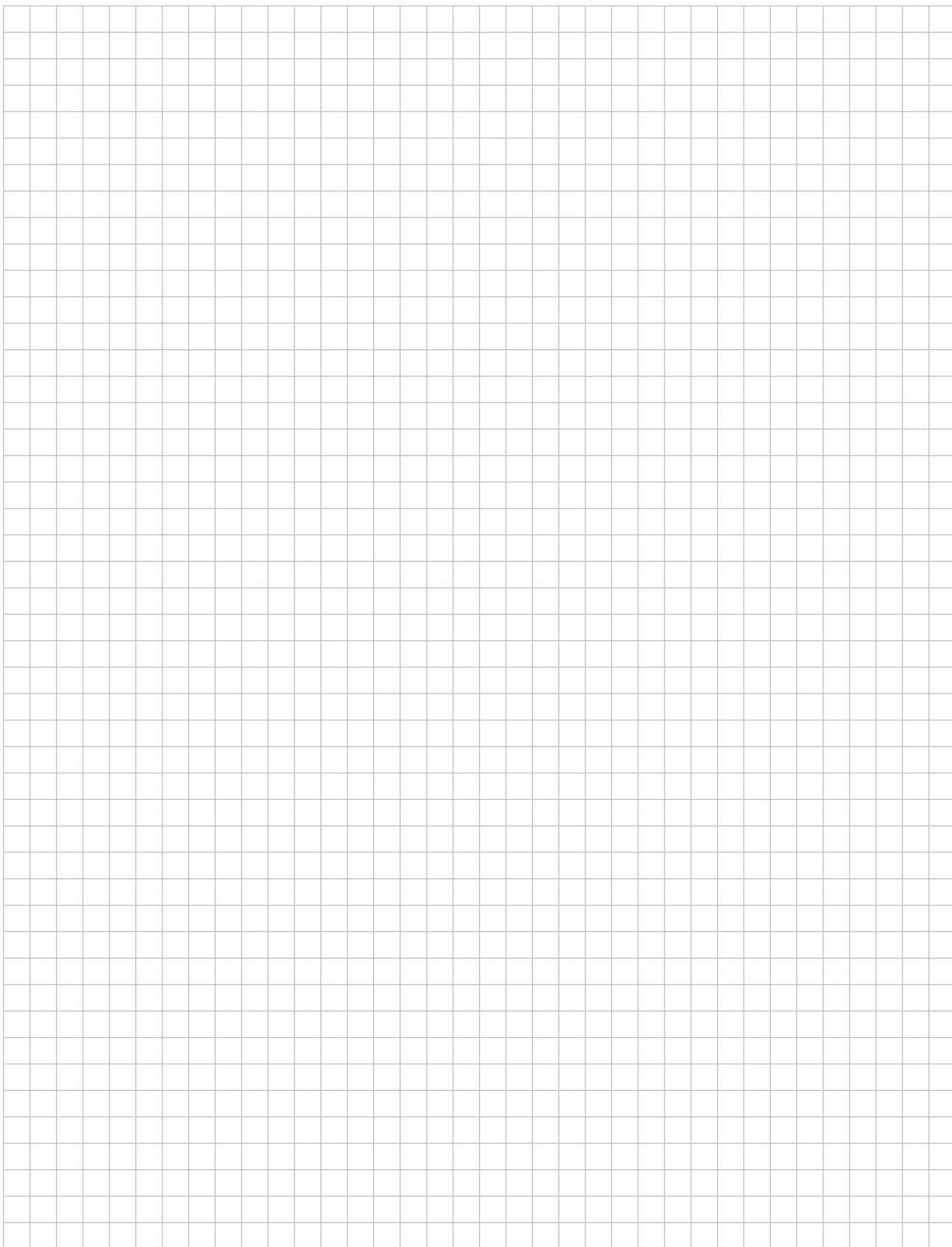

## 1

# Roller Chains for Power Transmission

- General
- Standard Roller Chain
- High-strength Roller Chain Series
- Ultimate Life Chain Series
- Environment Resistance Chain Series
- Low Noise Chain Series
- Specialty Chain Series

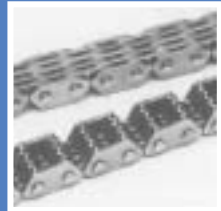

Classification by use	Product No.	Page	Functions										Allowable ambient temperature		
			High tension	Wear resistance	Dusty circumstances	Resistant against corrosive gas	Resistant against alkali, acid liquid	Hygiene circumstances	Low Noise	High temperature	Low temperature				
Standard Roller Chain	JIS · ISO	P18~47													
High-strength Roller Chain Series	HK	P48~63												-10~80 °C	
	HI-PWR-S														
	HI-PWR-S HK														
Ultimate Life Chain Series	T, D	P68~71													
	DHA	P72~79													
	UR												-10~60 °C		
	UR-F													-10~200 °C	
	LX, LD													-10~120 °C	
	LDSSP													120~200 °C	
Environment Resistance Chain Series	N		P82~87												-10~80 °C
	E														
	WG														
	SS	P88~91												-10~400 °C	
	SSK														
	SSLT														
TK	P92,93												-40~80 °C		
Low Noise Chain Series	UN	P94~97												-10~80 °C	
Specialty Chain Series	Bicycle Chain	P101~103,106													
	Small pitch Chain														
	Engine Eechanism chain														
	Agricultural Roller Chain														
	Silent Chain	SCA, SCR, SC	P104,105												
		PS													
	BS roller Chain	ISO-B	P107												
Leaf Chain	AL	P108,109													
	BL														



## Dimensions and Performance of DID General Application Chains

DID general application chains can be classified into two types in reference to strength; standard series chains complying with ANSI roller chains and HK series chains complying with ANSI, which have outer and inner plates thicker than those of standard chains.

The standard series include two lines; standard roller chains, and HI-PWR-S chains improved in fatigue strength and shock resistance compared to the standard roller chains. You can use them as basic transmission chains for all applications ranging from low speed to high speed.

The HK series are improved in the strength of plates to allow heavy duty transmission mainly in a low speed range, and include two lines; HK roller chains and HI-PWR-SHK roller chains further enhanced in fatigue strength.

### Sprockets

The simplex chains can be engaged with standard sprockets of the corresponding nominal numbers. For sprockets, see P115 ~.

### Selection of chains

For selecting a standard roller chain or HI-PWR-S roller chain, refer to "Selection of Chains" (P120). However, only for a special case of low speed and less shock, "Low-speed selection method" (P121) can also be referred to.

For selecting an HK roller chain or HI-PWR-SHK roller chain, refer to "Slow-speed selection" (P121).

For selecting a connecting link or offset link, refer to "General selection". Since selection according to "Slow-speed selection" results in insufficient strength, please consult us.

### Number of chain strands and method for connecting outer plates with pins

For the numbers of available strands, refer to the table of "Dimensions" for each size of chain.

The standard method for connecting pins and plates is rivet type (RP).

The cotter type (CP) can be used for standard chains and HK chains of DID80 or larger.

\* As for HI-PWR-S chains and HI-PWR-SHK chains, only rivet type (RP) is available.

### Connecting links and offset links

For connecting links and offset links, refer to the table of "Dimensions" for each size of chain.

This section describes general application chains only. However, since many kinds of engine mechanism chains and agricultural roller chains are also available, please see the sections describing the respective items.

## How to Order Roller Chains for Power Transmission

- When you place an order for **DID60LX** with **160** links and **one R** connecting link as a loop:

**[Type indication]**

**DID 60 LX × 160 R E**

<p>DAIDO's product</p> <p>Size of chain</p> <p>Type of chain (LX indicates an O-ring chain)</p> <p>Chain No.</p>	<p>Indicates that the overall length of chain is 160 links.</p> <p>Type of connecting link</p> <p>Clip type — Clearance fit: R Interference fit: F</p> <p>Cotter pin type — Clearance fit: C Interference fit: H</p> <p>Some are inapplicable, depending on the chain size. See the table on P17.</p>	<p style="text-align: center;">Installation of connecting link</p> <p>B :  The connecting link is separate from the chain.</p> <p>E :  The connecting link is connected with the chain to form a loop.</p> <p>T :  The connecting link is connected with the chain, without forming a loop.</p>
--	---	---

- When you place an order for a cotter type connecting link of **DID80**, in which the pins are clearance-fitted with the upper plate:

**DID 80 · C J**

Chain No.	Indicates a connecting link.
Type of connecting link	

- When you place an order for **DID80CP** with **121** links, **three** offset links and **one C** connecting link as a straight chain.

**DID 80 CP × 117 LL + OJ × 3 + CJ +**

<p>Chain No.</p> <p>Method for connecting pins and plates Rivet: RP Cotter pin: CP No expression means RP.</p> <p>Indicates that the number of inner links from one end to the other end of a chain is 117.</p> <p>Indicates that 3 offset links (OJ) are required.</p> <p>Indicates a C connecting link.</p>	<p>If the components stated before and after this symbol position are to be connected when the chain is delivered, [ + ] (plus) sign is used, and if not connected, [ , ] (comma) sign is used.</p> <p>This symbol means that the last link is connected with the first link (to form a loop).</p> <p>See the table on P17 for the kinds of connecting and offset links.</p>
---	--

- When you place an order for an offset link of **DID60**:

**DID 60 · OJ**

Chain No.	Indicates an offset link. One-pitch type: OJ Two-pitch type: 2POJ
-----------	---

- When you place an order for a cotter type connecting link of **DID80HK**, in which the pins are interference-fitted with the upper plate:

**DID80HK · H J**

Chain No.	Indicates a connecting link.
Type of connecting link	

\*When you place an order, refer to "Set Number of Chains and Links" (P138).



# Construction and Components of Chain

A roller chain has a structure as illustrated below, and the names of the components are stated in the drawing. These components act as described below, and are designed to suit the respective actions.

Components	Pin	Pins support all the load acting on the chain, together with inner and outer plates, and when the chain is engaged with a sprocket, the pins slide as bearings. They are required to be high in shearing strength and bending strength, and especially wear resistance.
	Bushing	Bushings act to prevent the shock received through rollers when the chain is engaged with a sprocket from being directly transmitted to pins, and also act as bearings, along with the pins. So, they are required to be high in shock fatigue strength and wear resistance.
	Roller	Rollers act to smoothly bend the chain when the chain is engaged with a sprocket, to protect the chain from shock with the sprocket. They are required to be high in shock fatigue strength, collapse strength and wear resistance.
	Plate	Plates are subject to repeated tension of the chain, and sometimes a large shock. So, they are required to be high in tensile strength, and also in shock resistance and fatigue strength.

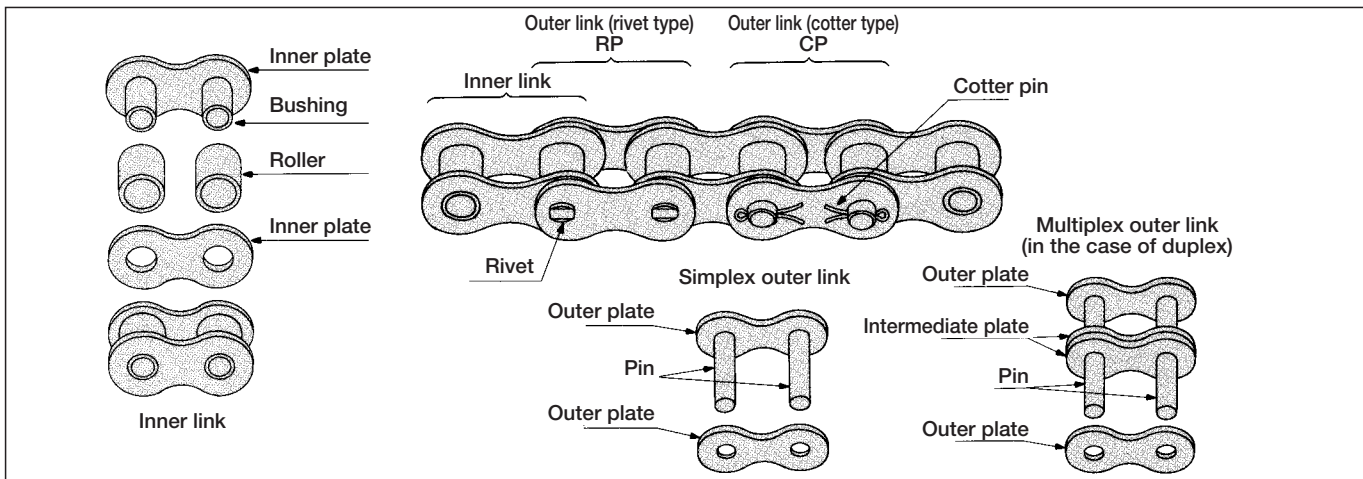

## Connecting links

The following four types of connecting links are available (R, F, C and H).

Clip type connecting link

Outer plate  
Connecting pin  
Connecting plate  
Clip

Clip type connecting link in which the connecting pins are clearance-fitted with the connecting plate is called an **R** connecting link (**RJ**), and that, interference-fitted, is called an **F** connecting link (**FJ**).

Cotter pin type connecting link

Outer plate  
Connecting pin  
Connecting plate  
Cotter pin

A cotter type connecting link in which the connecting pins are clearance-fitted with the connecting plate is called a **C** connecting link (**CJ**), and that, interference-fitted, is called an **H** connecting link (**HJ**).

Spring pin type connecting link

Outer plate  
Spring pin type connecting pin  
Connecting plate  
Spring pin

In a standard spring pin type connecting link, the connecting pins are interference-fitted with the connecting plates (**H** connecting link). **HI-PWR-S**, **HK** and **HI-PWR-SHK** series adopt this type.

## Offset link

An offset link is used for increasing or decreasing the length of a chain by one pitch, and the following two types are generally available.

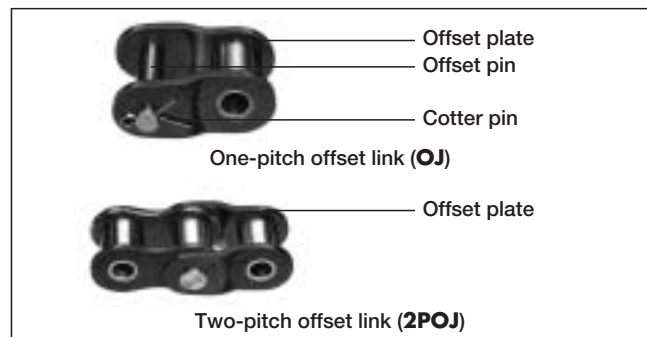

Since the "connecting link" and "offset link" are lower than the base chain in strength, consult us when using them for any service condition in excess of the Max. kilowatt ratings.

### \* Clearance fit

In this fit, a clearance is always formed between the pin and the hole when they are assembled. This method is used in standard connecting links.

### \* Interference fit

In this fit, an interference always occurs when the pin and the hole are assembled. This method is adopted in base chains and H connecting links. However, in H connecting links, the interference is smaller than that of the chain body.



## Worldwide standard chains complying with JIS and ANSI

The 14 sizes of DID standard roller chains are available ranging from DID25 to DID240 including those in conformity with ANSI (American National Standard Institute), and ISO (International Organization for Standardization).

The chains not only meet the requirements for the minimum tensile strength prescribed by ANSI and ISO, but they also provide the top class quality in the world including a high fatigue strength.

### Suitable uses

- General use for driving and lifting equipment.

### Examples

- Driving transfer units and other equipment. For multilevel parking.



## Selection of chains

For selection of a chain, see the tables of "Max. Horsepower Ratings" for standard roller chains (P20 ~ P47) and "Designing of Chain Transmission" (P120 ~ P126).

However, only for a special case of low speed and less shock, "Low-speed selection" method (P121) can also be referred to.

Standard roller chains up to five strands are available.

The standard method for connecting pins and plates is rivet type (RP).

The cotter type (CP) is available for standard chains and HK chains of DID80 or larger.

## Sprockets

The standard roller chains can be engaged with standard sprockets of the corresponding nominal numbers. For sprockets, refer to the table of "Dimensions" for each size of chain.

## Connecting links and offset links

For connecting links and offset links, refer to the table of "Dimensions" for each size of chain.

The connecting links are generally R or C connecting links in which the pins are clearance-fitted with the connecting plate. Since clearance-fitted links are inferior to the base chain in Max. allowable tension as in the case of one-pitch offset links (OJ), "Low-speed selection" (P121) cannot be referred to. Since the Max. kilowatt ratings are decided considering the strength of connecting links and OJ, the clearance-fitted connecting links and OJ can be used if the chains are selected according to the "General selection".

When a higher Max. allowable tension is required for the connecting link, use the interference-fitted connecting link (H connecting link) of a HI-PWR-S chain, and in the case of offset links, use 2POJ. For details, refer to the table of "Dimensions" for each size of chain.

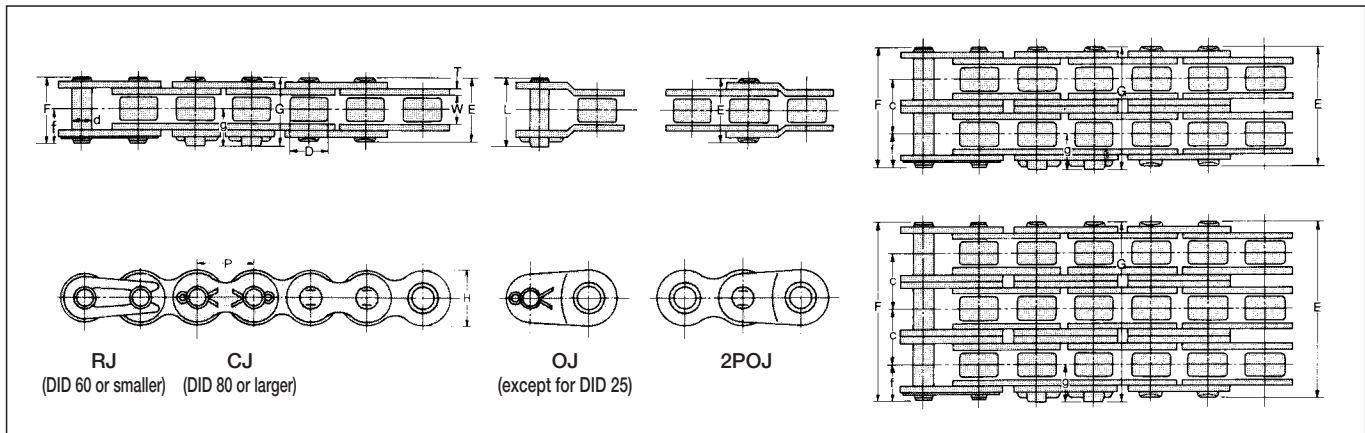

## Dimensions

Unit (mm)

Chain No.	Pitch	Roller Link Width	Bush Dia.	Pin								Transverse Pitch	Plate		JIS		DID		DID		Approx. weight (kg/m)	No. of links per unit		
				d	E	F	G	L	f	g	C		T	H	Min. Tensile Strength	Min. Tensile Strength	Avg. Tensile Strength	Max. Allowable Load						
DID	JIS	P	W	D	d	E	F	G	L	f	g	C	T	H	kN	kgf	kN	kgf	kN	kgf	kN	kgf		
*DID 25	25	6.35	3.18	(3.30)	2.31	7.8	8.5	—	—	4.7	—	6.4	0.72	5.9	3.6	367	3.63	370	4.41	450	0.73	75	0.13	160
*DID 35	35	9.525	4.78	(5.08)	3.59	12.0	13.1	—	—	7.3	—	10.1	1.25	9.0	8.7	887	8.83	900	11.2	1,150	2.15	220	0.32	320
DID 41	41	12.70	6.38	7.77	3.59	13.7	14.6	—	15.3	7.9	—	—	1.20	9.6	7.4	754	8.83	900	10.7	1,100	2.35	240	0.39	240
DID 40	40	12.70	7.95	7.92	3.97	16.5	17.6	—	19.3	9.5	—	14.4	1.50	12.0	15.2	1,549	15.69	1,600	19.1	1,950	3.72	380	0.63	240
DID 50	50	15.875	9.53	10.16	5.09	20.3	21.9	—	23.1	11.6	—	18.1	2.00	15.0	24	2,447	26.48	2,700	30.8	3,150	6.86	700	1.06	192
DID 60	60	19.05	12.70	11.91	5.96	25.4	26.9	27.9	30.0	14.3	15.1	22.8	2.40	18.1	34.2	3,487	35.30	3,600	44.1	4,500	9.31	950	1.44	160
DID 80	80	25.40	15.88	15.88	7.94	32.6	—	35.4	36.4	—	19.0	29.3	3.20	24.0	61.2	6,240	71.59	7,300	78.4	8,000	14.7	1,500	2.55	120
DID 100	100	31.75	19.05	19.05	9.54	39.5	—	42.5	43.5	—	22.8	35.8	4.00	29.9	95.4	9,728	107.8	11,000	118	12,100	22.5	2,300	3.79	96
DID 120	120	38.10	25.40	22.23	11.11	49.7	—	53.0	54.1	—	28.2	45.4	4.80	35.9	137.1	13,980	147.1	15,000	166	17,000	30.4	3,100	5.49	80
DID 140	140	44.45	25.40	25.40	12.71	53.6	—	58.4	59.6	—	31.6	48.9	5.60	41.9	185.9	18,956	193.1	19,700	215	22,000	40.2	4,100	7.11	68
DID 160	160	50.80	31.75	28.58	14.29	63.6	—	68.2	69.7	—	36.4	58.5	6.40	47.8	244.6	24,942	245.1	25,000	269	27,500	52.9	5,400	9.82	60
DID 180	180	57.15	35.72	35.71	17.46	71.5	—	77.3	79.3	—	41.4	65.8	7.10	53.8	308.2	31,427	333.4	34,000	362	37,000	61.7	6,300	12.7	54
DID 200	200	63.50	38.10	39.68	19.85	77.9	—	85.0	87.3	—	45.9	71.6	8.00	60.0	381.7	38,922	431.4	44,000	470	48,000	73.5	7,500	16.5	48
DID 240	240	76.20	47.63	47.63	23.81	95.2	—	102.9	105.4	—	55.3	87.8	9.50	71.5	550.4	56,125	622.7	63,500	686	70,000	99.0	10,100	23.3	40

Note: 1. Those marked with \* indicate bushing chains.

2. The values of average tensile strength and Max. allowable load are for chains.

## DID 25 standard roller chain

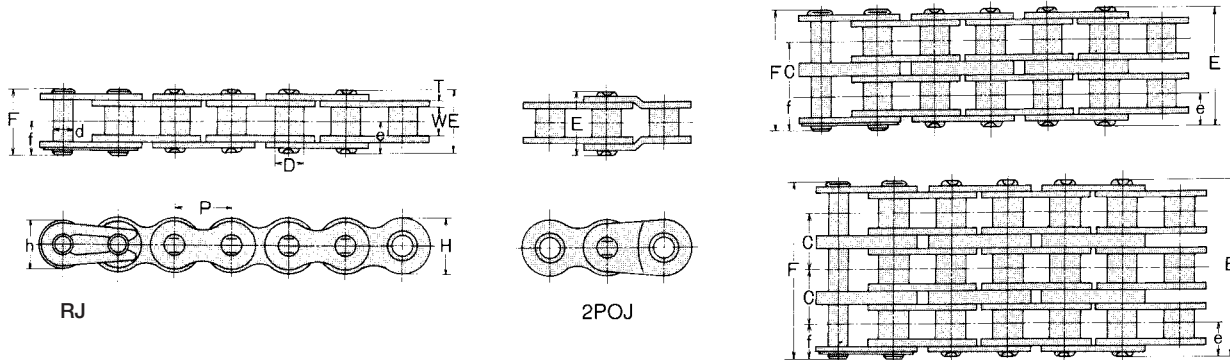

### Dimensions

Chain No.		Pitch <b>P</b>	Roller Link Width <b>W</b>	Bush Dia. <b>D</b>	Pin					Transverse Pitch <b>C</b>	Plate			JIS Min. Tensile Strength		DID Min. Tensile Strength		DID Avg. Tensile Strength		DID Max. Allowable Load		Approx. Weight (kg/m)
DID	JIS				<b>d</b>	<b>E</b>	<b>F</b>	<b>e</b>	<b>f</b>		<b>T</b>	<b>H</b>	<b>h</b>	kN	kgf	kN	kgf	kN	kgf	kN	kgf	
<b>DID25</b>	25					7.8	8.5				3.6	367	3.63	370	4.41	450	0.73	75	0.13			
<b>DID25-2</b>	25-2					14.4	15.0				7.2	734	7.26	740	8.82	900	1.17	120	0.26			
<b>DID25-3</b>	25-3	6.35	3.18	3.30	2.31	20.8	21.4	3.9	4.7	6.4	0.72	5.9	5.2	10.8	1,101	10.89	1,110	13.20	1,350	1.76	180	0.39
<b>DID25-4</b>	25-4					27.2	27.8							14.4	1,468	14.52	1,480	17.60	1,800	2.35	240	0.52
<b>DID25-5</b>	25-5					33.7	34.3							18.0	1,835	18.15	1,850	20.00	2,250	2.84	290	0.65

Note: Values of average tensile strength and max. allowable load are for chain body.

### Max. Kilowatt Ratings

No. of Teeth of Small Sprocket	Type of Lubrication	Small Sprocket revolutions per minute (rpm) (See P132 for the details of type of lubrication A, B and C.)																			
		A										B									C
		100	500	900	1200	1800	2500	3000	3500	4000	4500	5000	5500	6000	6500	7000	7500	8000	8500	9000	
11		0.04	0.18	0.31	0.40	0.58	0.77	0.91	1.05	1.03	0.86	0.74	0.64	0.56	0.50	0.44	0.40	0.36	0.33	0.30	0.26
12		0.05	0.20	0.34	0.44	0.63	0.85	1.00	1.15	1.17	0.98	0.84	0.73	0.64	0.57	0.51	0.46	0.41	0.38	0.35	0.30
13		0.05	0.22	0.37	0.48	0.69	0.93	1.09	1.25	1.32	1.11	0.95	0.82	0.72	0.64	0.57	0.51	0.47	0.43	0.39	0.33
14		0.06	0.24	0.40	0.52	0.75	1.00	1.18	1.36	1.48	1.24	1.06	0.92	0.80	0.71	0.64	0.58	0.52	0.48	0.44	0.37
15		0.06	0.25	0.43	0.56	0.80	1.08	1.27	1.46	1.64	1.37	1.17	1.02	0.89	0.79	0.71	0.64	0.58	0.53	0.49	0.41
16		0.06	0.27	0.46	0.60	0.86	1.16	1.37	1.57	1.77	1.51	1.29	1.12	0.98	0.87	0.78	0.70	0.64	0.58	0.53	0.46
17		0.07	0.29	0.49	0.64	0.92	1.24	1.46	1.67	1.89	1.66	1.41	1.23	1.08	0.95	0.85	0.77	0.70	0.64	0.59	0.50
18		0.07	0.31	0.52	0.68	0.98	1.32	1.55	1.78	2.01	1.81	1.54	1.34	1.17	1.04	0.93	0.84	0.76	0.70	0.64	0.54
19		0.08	0.33	0.56	0.72	1.04	1.40	1.64	1.89	2.13	1.96	1.67	1.45	1.27	1.13	1.01	0.91	0.83	0.75	0.69	0.59
20		0.08	0.35	0.59	0.76	1.10	1.47	1.74	2.00	2.25	2.11	1.81	1.56	1.37	1.22	1.09	0.98	0.89	0.81	0.75	0.64
21		0.09	0.37	0.62	0.80	1.16	1.55	1.83	2.10	2.37	2.27	1.94	1.68	1.48	1.31	1.17	1.06	0.96	0.88	0.80	0.69
22		0.09	0.38	0.65	0.84	1.22	1.63	1.93	2.21	2.50	2.44	2.08	1.81	1.58	1.40	1.26	1.13	1.03	0.94	0.86	0.74
23		0.09	0.40	0.68	0.89	1.28	1.71	2.02	2.32	2.62	2.61	2.23	1.93	1.69	1.50	1.34	1.21	1.10	1.00	0.92	0.79
24		0.10	0.42	0.72	0.93	1.34	1.80	2.12	2.43	2.74	2.78	2.37	2.06	1.81	1.60	1.43	1.29	1.17	1.07	0.98	0.84
25		0.10	0.44	0.75	0.97	1.40	1.88	2.21	2.54	2.86	2.95	2.52	2.19	1.92	1.70	1.52	1.37	1.25	1.14	1.04	0.89
28		0.12	0.50	0.85	1.10	1.58	2.12	2.50	2.87	3.24	3.50	2.99	2.59	2.27	2.02	1.81	1.63	1.48	1.35	1.24	1.06
30		0.13	0.54	0.91	1.18	1.70	2.28	2.69	3.09	3.49	3.88	3.32	2.87	2.52	2.24	2.00	1.81	1.64	1.50	1.37	1.17
32		0.14	0.58	0.98	1.27	1.82	2.45	2.89	3.32	3.74	4.16	3.65	3.17	2.78	2.46	2.21	1.99	1.81	1.65	1.51	1.29
35		0.15	0.63	1.08	1.39	2.01	2.70	3.18	3.65	4.12	4.58	4.18	3.62	3.18	2.82	2.52	2.27	2.06	1.89	1.73	1.48
40		0.17	0.73	1.24	1.61	2.32	3.12	3.67	4.22	4.76	5.29	5.11	4.43	3.88	3.44	3.08	2.78	2.52	2.30	2.11	1.81
45		0.20	0.83	1.41	1.83	2.63	3.54	4.17	4.79	5.40	6.01	6.09	5.28	4.63	4.11	3.68	3.32	3.01	2.75	2.52	2.15

Note: Values in the table above are for single strand chains only. For multiplex chains, please apply the coefficient of multi-strand. (See "Chain Selection" on P120).

# DID 25 Standard Sprocket

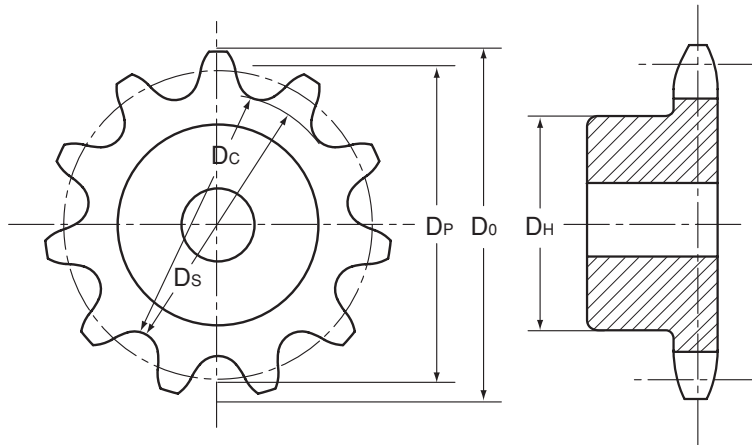

DID 25 sprocket is made to order.

Unit (mm)

Number of Teeth <b>N</b>	Pitch Dia <b>DP</b>	Tip Dia <b>DO</b>	Root Dia <b>DS</b>	Caliper Dia <b>DC</b>	Max. Hub Dia <b>DH</b>
11	22.54	25	19.24	19.01	15
12	24.53	28	21.23	21.23	17
13	26.53	30	23.23	23.04	19
14	28.54	32	25.24	25.24	21
15	30.54	34	27.24	27.07	23
16	32.55	36	29.25	29.25	25
17	34.56	38	31.26	31.11	27
18	36.57	40	33.27	33.27	29
19	38.58	42	35.28	35.15	31
20	40.59	44	37.29	37.29	33
21	42.61	46	39.31	39.19	35
22	44.62	48	41.32	41.32	37
23	46.63	50	43.33	43.23	39
24	48.65	52	45.35	45.35	41
25	50.66	54	47.36	47.27	43
26	52.68	56	49.38	49.38	45
27	54.70	58	51.40	51.30	47
28	56.71	60	53.41	53.41	49
29	58.73	62	55.43	55.35	51
30	60.75	64	57.45	57.45	53
31	62.77	66	59.47	59.39	55
32	64.78	68	61.48	61.48	57
33	66.80	70	63.50	63.43	59
34	68.82	72	65.52	65.52	61
35	70.84	74	67.54	67.47	63
36	72.86	76	69.56	69.56	65
37	74.88	78	71.58	71.51	67
38	76.90	80	73.60	73.60	70
39	78.91	82	75.61	75.55	72
40	80.93	84	77.63	77.63	74
41	82.95	87	79.65	79.59	76
42	84.97	89	81.67	81.67	78
43	86.99	91	83.69	83.63	80
44	89.01	93	85.71	85.71	82
45	91.03	95	87.73	87.68	84
48	97.09	101	93.79	93.79	90
50	101.13	105	97.83	97.83	94
54	109.21	113	105.91	105.91	102
55	111.23	115	107.93	107.88	104
60	121.33	125	118.03	118.03	114
65	131.43	135	128.13	128.10	124
70	141.54	145	138.24	138.24	134
75	151.64	155	148.34	148.31	144



## DID 35 standard roller chain

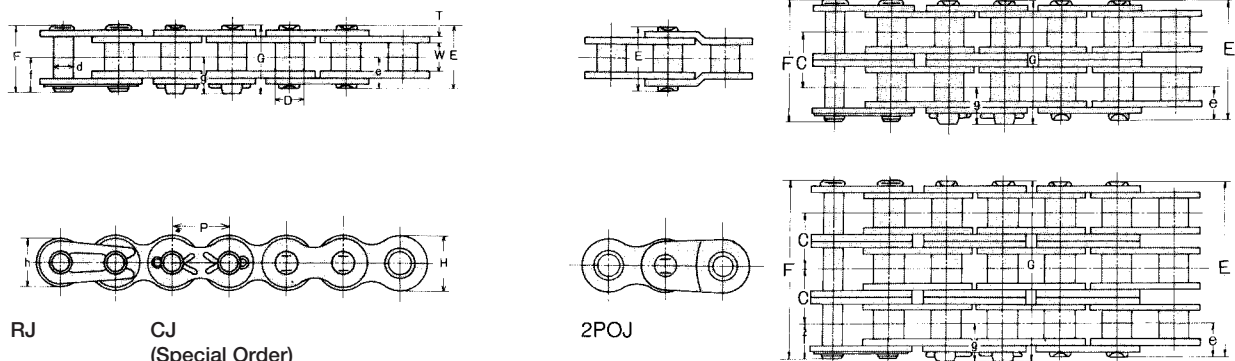

RJ

CJ  
(Special Order)

2POJ

### Dimensions

Unit (mm)

Chain No.		Pitch P	Roller Link Width W	Bush Dia. D	Pin						Transvers e Pitch C	Plate				JIS Min. Tensile Strength		DID Min. Tensile Strength		DID Avg. Tensile Strength		DID Max. Allowable Load		Approx. Weight (kg/m)
DID	JIS				d	E	F	G	e	f		g	T	H	h	kN	kgf	kN	kgf	kN	kgf	kN	kgf	
<b>DID35</b>	35					12.0	13.1	14.1								8.7	887	8.83	900	11.2	1,150	2.15	220	0.32
<b>DID35-2</b>	35-2					22.1	23.2	23.5								17.4	1,774	17.66	1,800	22.5	2,300	3.62	370	0.69
<b>DID35-3</b>	35-3	9.525	4.78	5.08	3.59	32.2	33.4	33.7	6.0	7.3	7.4	10.1	1.25	9.0	7.75	26.1	2,661	26.49	2,700	33.8	3,450	5.39	550	1.05
<b>DID35-4</b>	35-4					42.3	43.5	43.8								34.8	3,548	35.32	3,600	45.1	4,600	7.06	720	1.41
<b>DID35-5</b>	35-5					52.5	53.7	54.0								43.5	4,435	44.15	4,500	56.3	5,750	8.33	850	1.77

Note: The values of average tensile strength and Max. allowable tension are for chains.

### Max. Kilowatt Ratings DID 35

Unit (kW)

No. of Teeth of Small Sprocket	Type of Lubrication	Small Sprocket revolutions per minute (rpm) (See P132 for the details of type of lubrication A, B and C.)																																																																																																						
		100					500					900					1200					1800					2500					3000					3500					4000					4500					5000					5500					6000					6500					7000					7500					8000					8500					9000					10000							
		A					B					C					A					B					C					A					B					C					A					B					C					A					B					C					A					B					C					A					B					C		
11		0.17	0.74	1.26	1.63	2.34	2.88	2.19	1.74	14.2	1.19	1.02	0.88	0.77	0.69	0.61	0.55	0.50	0.46	0.42	0.36																																																																																			
12		0.19	0.81	1.38	1.79	2.57	3.28	2.50	1.98	1.62	1.36	1.16	1.01	0.88	0.78	0.70	0.63	0.57	0.52	0.48	0.41																																																																																			
13		0.21	0.89	1.50	1.95	2.81	3.70	2.82	2.23	1.83	1.53	1.31	1.13	1.00	0.88	0.79	0.71	0.65	0.59	0.54	0.46																																																																																			
14		0.23	0.96	1.63	2.11	3.04	4.09	3.15	2.50	2.04	1.71	1.46	1.27	1.11	0.99	0.88	0.80	0.72	0.66	0.61	0.52																																																																																			
15		0.24	1.03	1.76	2.27	3.28	4.40	3.49	2.77	2.27	1.90	1.62	1.41	1.23	1.09	0.98	0.88	0.80	0.73	0.67	0.57																																																																																			
16		0.26	1.11	1.88	2.44	3.51	4.72	3.84	3.05	2.50	2.09	1.79	1.55	1.36	1.21	1.08	0.97	0.88	0.81	0.74	0.63																																																																																			
17		0.28	1.18	2.01	2.60	3.75	5.04	4.21	3.34	2.73	2.29	1.96	1.70	1.49	1.32	1.18	1.07	0.97	0.88	0.81	0.69																																																																																			
18		0.30	1.26	2.14	2.77	3.99	5.36	4.59	3.64	2.98	2.50	2.13	1.85	1.62	1.44	1.29	1.16	1.05	0.96	0.88	0.75																																																																																			
19		0.31	1.33	2.27	2.94	4.23	5.68	4.97	3.95	3.23	2.71	2.31	2.00	1.76	1.56	1.40	1.26	1.14	1.04	0.96	0.82																																																																																			
20		0.33	1.41	2.39	3.10	4.47	6.01	5.37	4.26	3.49	2.92	2.50	2.16	1.90	1.68	1.51	1.36	1.23	1.13	1.03	0.88																																																																																			
21		0.35	1.49	2.52	3.27	4.71	6.33	5.78	4.59	3.75	3.15	2.69	2.33	2.04	1.81	1.62	1.46	1.33	1.21	1.11	0.95																																																																																			
22		0.37	1.56	2.65	3.44	4.95	6.66	6.20	4.92	4.03	3.37	2.88	2.50	2.19	1.94	1.74	1.57	1.42	1.30	1.19	1.02																																																																																			
23		0.39	1.64	2.78	3.61	5.20	6.98	6.63	5.26	4.30	3.61	3.08	2.67	2.34	2.08	1.86	1.68	1.52	1.39	1.27	1.09																																																																																			
24		0.40	1.72	2.92	3.78	5.44	7.31	7.06	5.60	4.59	3.84	3.28	2.84	2.50	2.21	1.98	1.79	1.62	1.48	1.36	1.16																																																																																			
25		0.42	1.80	3.05	3.95	5.69	7.64	7.51	5.96	4.88	4.09	3.49	3.02	2.65	2.35	2.11	1.90	1.72	1.57	1.44	1.23																																																																																			
28		0.48	2.03	3.44	4.46	6.43	8.64	8.90	7.06	5.78	4.84	4.14	3.58	3.15	2.79	2.50	2.25	2.04	1.87	1.71	1.46																																																																																			
30		0.51	2.19	3.71	4.81	6.92	9.31	9.87	7.83	6.41	5.37	4.59	3.98	3.49	3.09	2.77	2.50	2.27	2.07	1.90	1.62																																																																																			
32		0.55	2.34	3.98	5.15	7.42	9.98	10.9	8.63	7.06	5.92	5.05	4.38	3.84	3.41	3.05	2.75	2.50	2.28	2.09	1.79																																																																																			
35		0.61	2.58	4.38	5.68	8.18	11.0	12.4	9.87	8.08	6.77	5.78	5.01	4.40	3.90	3.49	3.15	2.86	2.61	2.39																																																																																				
40		0.70	2.98	5.06	6.56	9.45	12.7	15.0	12.1	9.87	8.27	7.06	6.12	5.37	4.76	4.26	3.84	3.49																																																																																						
45		0.80	3.39	5.57	7.45	10.7	14.4	17.0	14.4	11.8	9.87	8.43	7.30	6.41	5.68	5.09	4.59																																																																																							

Note: Values in the above table are for simplex chain only. For multiplex chains, please multiply the coefficient of multi-strand. (See "Chain Selection" on P.120).

# DID 35 Standard Sprocket

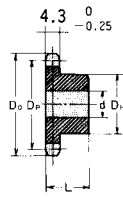

Single sprocket with hub on one side (Single B type)

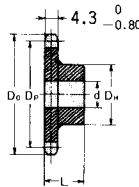

Single sprocket with hub on one side (Single BW type welded)

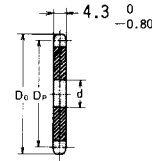

Flat Plain (A type)

Unit (mm)

Number of teeth	Pitch dia. DP	Tip dia. D <sub>o</sub>	Single sprocket with hub on one side (B type/ BW type)						Flat plain (A type)			Number of teeth
			Bore d		Hub		Approx. weight (Kg)	Material	Stock d	Approx. weight (Kg)	Material	
			Stock	Max.	(Dia.) D <sub>H</sub>	(Length) L						
9	27.85	32	8	11	22※	20	0.06	S35C	8	SS400	9	
10	30.82	34	8	12	25※	20	0.08		8		0.02	10
11	33.81	38	8	14	27※	20	0.09		9.5		0.03	11
12	36.80	40	8	16.5	31※	20	0.12		9.5		0.03	12
13	39.80	44	9	18	32※	20	0.12		9.5		0.04	13
14	42.81	46	9	16.5	30	20	0.12		9.5		0.04	14
15	45.81	51	9	19	35	20	0.16		9.5		0.05	15
16	48.82	53	9	20	37	20	0.19		9.5		0.05	16
17	51.84	57	11	24	41	20	0.22		12		0.07	17
18	54.85	60	11	24.5	44	20	0.25		12		0.07	18
19	57.87	63	11	28.5	47	20	0.28		12		0.09	19
20	60.89	66	11	30	50	20	0.32		12		0.09	20
21	63.91	69	11	32	53	20	0.36		12		0.11	21
22	66.93	72	11	32	53	20	0.37		12		0.11	22
23	69.95	75	11	32	53	20	0.38		12		0.11	23
24	72.97	78	11	32	53	22	0.43		12		0.14	24
25	76.00	81	11	32	53	22	0.44		12		0.16	25
26	79.02	83	11	32	53	22	0.45		12		0.16	26
27	82.05	87	11	32	53	22	0.46		12		0.17	27
28	85.07	90	11	32	53	22	0.48		12		0.18	28
29	88.08	93	11	32	53	22	0.49		12		0.20	29
30	91.12	96	11	32	53	22	0.51		12		0.23	30
31	94.16	99	11	32	53	22	0.52		12		0.24	31
32	97.18	102	11	32	53	22	0.54		12		0.27	32
33	100.20	105	11	32	53	22	0.55		12		0.28	33
34	103.23	109	11	32	53	22	0.57		12		0.29	34
35	106.26	112	11	32	53	22	0.59		12		0.30	35
36	109.29	115	11	32	53	22	0.61		13		0.32	36
37	112.32	117	11	42	62	22	0.82		13		0.37	37
38	115.34	121	11	42	62	25	0.82		13		0.41	38
39	118.36	123	11	42	62	25	0.83	13	0.42	39		
40	121.40	127	11	42	62	25	0.85	13	0.43	40		
41	124.43	129	12	42	62	25	0.85	SS400 Welded	13	41		
42	127.46	132	12	42	62	25	0.86			42		
43	130.48	135	12	42	62	25	0.87			43		
44	133.53	138	12	42	62	25	0.90			44		
45	136.55	142	12	42	62	25	0.95			45		
48	145.64	151	12	42	62	25	1.00			48		
50	151.69	157	12	42	62	25	1.05			50		
54	163.81	169	12	42	62	25	1.20			54		
55	166.85	172	12	42	62	25	1.22			55		
60	182.00	187	12	42	62	25	1.30			60		
65	197.15	202	12	42	67	25	1.50	65				
70	212.30	218	12	45	67	25	1.70	70				
75	227.46	233	12	45	67	25	1.80	75				

- Note: 1. Determine the required bore size less than the Max. value shown above taking strength reduction into consideration.  
 2. The shaded area of the above table indicates heat treated teeth.  
 3. Those marked \* have slot on hub.



## DID 41 standard roller chain

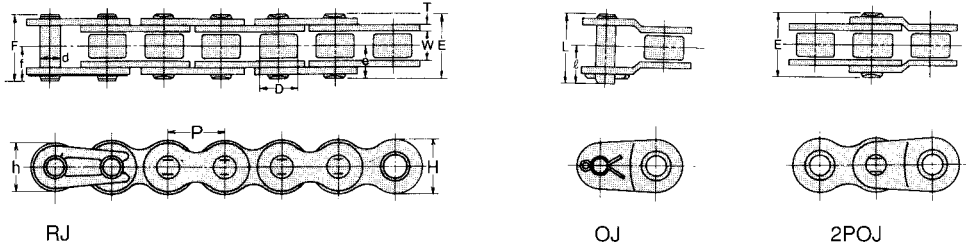

### Dimensions

Unit (mm)

Chain No.		Pitch <b>P</b>	Roller Link Width <b>W</b>	Roller dia. <b>D</b>	Pin							Plate			JIS Min. Tensile Strength		DID Min. Tensile Strength		DID Avg. Tensile Strength		DID Max. Allowable Load		概略質量 (kg/m)
<b>DID</b>	<b>JIS</b>				<b>d</b>	<b>E</b>	<b>F</b>	<b>L</b>	<b>e</b>	<b>f</b>	<b>l</b>	<b>T</b>	<b>H</b>	<b>h</b>	kN	kgf	kN	kgf	kN	kgf	kN	kgf	
<b>DID 41</b>	41	12.70	6.38	7.77	3.59	13.7	14.6	15.3	6.9	7.9	8.5	1.20	9.6	8.0	7.40	754	8.83	900	10.7	1,100	2.35	240	0.39

Note: The values of average tensile strength and Max. allowable tension are for chains.

### Max. Kilowatt Ratings DID 41

Unit (kW)

Type of Lubrication No. of Teeth of Small Sprocket	Small sprocket rpm (Refer to P132 for the details of lubrication A, B and C.)																		
	50	200	400	600	900	1200	1800	2400	3000	3500	4000	4500	5000	5500	6000	6500	7000	7500	8000
<b>11</b>	<b>A</b>			<b>B</b>									<b>C</b>						
<b>12</b>	0.11	0.40	0.74	1.06	1.53	1.28	0.69	0.45	0.32	0.26	0.21	0.18	0.15	0.13	0.11	0.10	0.09	0.08	0.07
<b>13</b>	0.12	0.43	0.81	1.17	1.68	1.45	0.79	0.51	0.37	0.29	0.24	0.20	0.17	0.15	0.13	0.12	0.10	0.09	0.08
<b>14</b>	0.14	0.47	0.88	1.27	1.84	1.64	0.89	0.58	0.41	0.33	0.27	0.23	0.19	0.17	0.15	0.13	0.12	0.10	0.10
<b>15</b>	0.15	0.51	0.96	1.38	1.99	1.83	1.00	0.65	0.46	0.37	0.30	0.25	0.22	0.19	0.16	0.15	0.13	0.12	0.11
<b>16</b>	0.16	0.55	1.03	1.49	2.14	2.03	1.11	0.72	0.51	0.41	0.33	0.28	0.24	0.21	0.18	0.16	0.14	0.13	
<b>17</b>	0.17	0.59	1.11	1.59	2.30	2.24	1.22	0.79	0.57	0.45	0.37	0.31	0.26	0.23	0.20	0.18	0.16	0.14	
<b>18</b>	0.18	0.63	1.18	1.70	2.45	2.45	1.33	0.87	0.62	0.49	0.40	0.34	0.29	0.25	0.22	0.19	0.17	0.16	
<b>19</b>	0.19	0.67	1.26	1.81	2.61	2.67	1.45	0.94	0.68	0.54	0.44	0.37	0.31	0.27	0.24	0.21	0.19	0.17	
<b>20</b>	0.21	0.71	1.33	1.92	2.77	2.90	1.58	1.02	0.73	0.58	0.48	0.40	0.34	0.30	0.26	0.23	0.21	0.19	
<b>21</b>	0.22	0.76	1.41	2.03	2.92	3.13	1.70	1.11	0.79	0.63	0.51	0.43	0.37	0.32	0.28	0.25	0.22	0.20	
<b>22</b>	0.23	0.80	1.49	2.14	3.08	3.36	1.83	1.19	0.85	0.68	0.55	0.46	0.40	0.34	0.30	0.27	0.24	0.22	
<b>23</b>	0.24	0.84	1.56	2.25	3.24	3.61	1.96	1.28	0.91	0.72	0.59	0.50	0.42	0.37	0.32	0.29	0.26		
<b>24</b>	0.25	0.88	1.64	2.36	3.40	3.86	2.10	1.36	0.98	0.77	0.63	0.53	0.45	0.39	0.34	0.31	0.27		
<b>25</b>	0.26	0.92	1.72	2.47	3.56	4.11	2.24	1.45	1.04	0.83	0.68	0.57	0.48	0.42	0.37	0.33	0.29		
<b>28</b>	0.28	0.96	1.79	2.58	3.72	4.37	2.38	1.54	1.11	0.88	0.72	0.60	0.51	0.45	0.39	0.35			
<b>30</b>	0.31	1.09	2.03	2.92	4.20	5.18	2.82	1.83	1.31	1.04	0.85	0.71	0.61	0.53	0.46	0.41			
<b>32</b>	0.34	1.17	2.18	3.14	4.53	5.74	3.13	2.03	1.45	1.15	0.94	0.79	0.68	0.59	0.51				
<b>35</b>	0.36	1.25	2.34	3.37	4.86	6.29	3.44	2.24	1.60	1.27	1.04	0.87	0.74	0.64	0.57				
<b>40</b>	0.40	1.38	2.58	3.71	5.35	6.93	3.94	2.56	1.83	1.45	1.19	1.00	0.85	0.74					
<b>45</b>	0.46	1.60	2.98	4.29	6.18	8.01	4.81	3.13	2.24	1.78	1.45	1.22	1.04						
	0.52	1.81	3.38	4.87	7.02	9.09	5.74	3.73	2.67	2.12	1.73	1.45							

# DID 41 Standard Sprocket

DID 41 is for single only.

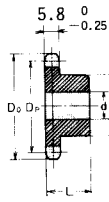

Single sprocket with hub on one side (Single B type)

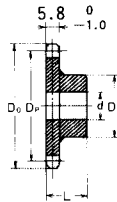

Single sprocket with hub on one side (Single BW type Welded)

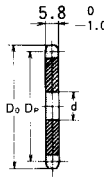

Flat plain (A type)

Unit (mm)

Number of teeth	Pitch dia. D <sub>p</sub>	Tip dia. D <sub>o</sub>	Single sprocket with hub on one side (B type/ BW type)						Flat plain (A type)			Number of teeth
			Bore d		Hub		Approx. weight (Kg)	Material	Stock d	Approx. weight (Kg)	Material	
			Stock	Max.	(Dia.) D <sub>H</sub>	(Length) L						
9	37.13	42	9	15	28*	22	0.11	S35C	9		SS400	9
10	41.10	46	9	16	32*	22	0.14		9	0.05		10
11	45.08	51	10	20	37*	22	0.19		10	0.06		11
12	49.07	53	10	22	40*	22	0.22		10	0.10		12
13	53.07	58	13	20	37	22	0.23		13	0.10		13
14	57.07	63	13	24	42	22	0.28		13	0.11		14
15	61.08	67	13	28	46	22	0.34		13	0.15		15
16	65.10	71	13	30	50	22	0.40		13	0.17		16
17	69.12	75	13	32	54	22	0.46		13	0.20		17
18	73.14	78	13	35	57	22	0.51		13	0.20		18
19	77.16	83	13	39	62	22	0.59		13	0.26		19
20	81.18	88	14	45	67	25	0.76		14	0.26		20
21	85.21	92	14	45	71	25	0.85		14	0.30		21
22	89.24	96	14	50	75	25	0.95		14	0.30		22
23	93.27	98	14	50	77	25	1.00		14	0.35		23
24	97.30	104	14	42	63	25	0.81		14	0.37		24
25	101.33	108	14	42	63	25	0.88		14	0.40		25
26	105.36	112	14	42	63	25	0.92		14	0.35		26
27	109.40	116	14	42	63	25	0.96		14	0.50		27
28	113.43	120	14	42	63	25	1.00		14	0.51		28
29	117.46	124	14	42	63	25	1.10	14	0.51	29		
30	121.50	128	14	42	63	25	1.10	14	0.60	30		
31	125.53	132	14	45	63	25	1.20	14	0.61	31		
32	129.57	137	14	45	68	28	1.30	14	0.68	32		
33	133.61	140	14	45	68	28	1.30	14	0.70	33		
34	137.64	145	14	45	68	28	1.30	14	0.75	34		
35	141.68	149	14	45	68	28	1.40	14	0.83	35		
36	145.72	153	17	45	67	28	1.40	SS400 Welded	17	0.90	36	
37	149.75	157	17	45	67	28	1.50		17	0.93	37	
38	153.79	161	17	45	67	28	1.50		17	0.95	38	
39	157.83	165	17	45	67	28	1.60		17	1.05	39	
40	161.87	169	17	45	67	28	1.60		17	1.06	40	
41	165.91	173	17	45	72	32	1.70		17	1.15	41	
42	169.95	177	17	48	72	32	2.00		17	1.20	42	
43	173.98	181	17	48	72	32	2.10		17	1.23	43	
44	178.02	185	17	48	72	32	2.20		17	1.30	44	
45	182.06	189	17	48	72	32	2.20		17	1.36	45	
48	194.18	201	17	48	72	32	2.30		17	1.53	48	
50	202.26	209	17	48	72	32	2.40		17	1.70	50	
54	218.42	226	17	48	72	32	2.80		17	2.00	54	
60	242.66	250	17	48	72	32	3.20		17	2.50	60	
65	262.87	270	17	55	82	32	3.90		17	2.87	65	
70	283.07	290	19	55	82	32	4.30	19	3.30	70		
72	291.16	299	19	55	82	32	4.80	19	3.40	72		
75	303.28	311	19	55	82	32	5.00	19	4.50	75		

- Note: 1. Determine the required bore size less than the Max. value shown above taking strength reduction into consideration.  
 2. Shaded area of the above dimension table indicates heat treated teeth.  
 3. Those marked \* have slot on hub.

## DID 40 standard roller chain

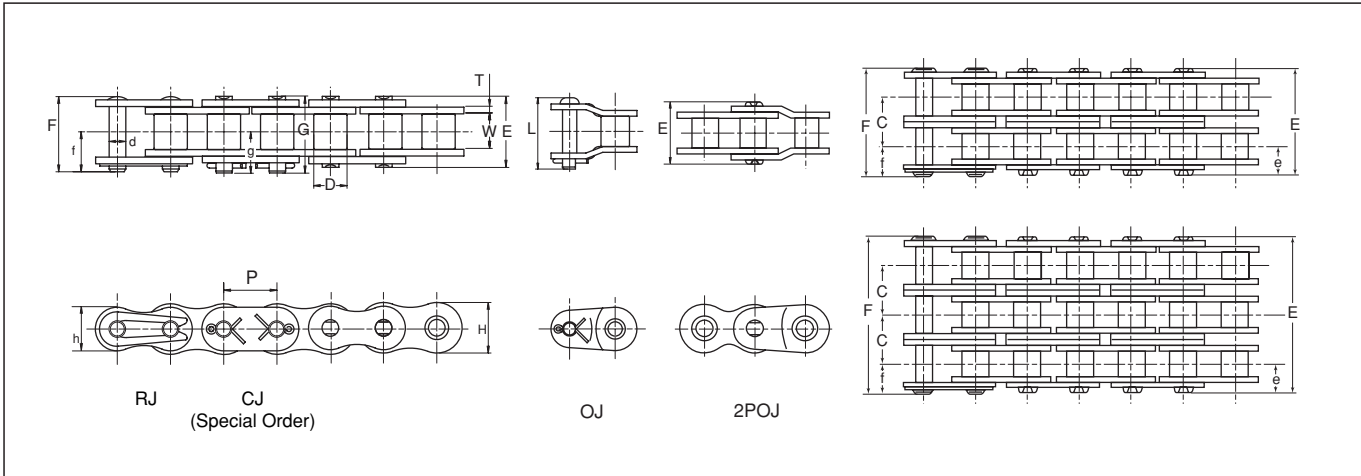

### Dimensions

Unit (mm)

Chain No.	Pitch	Roller Link Width W	Roller dia. D	Pin									Transverse Pitch C	Plate				JIS		DID		DID		Approx. Weight (kg/m)								
				d	E	F	G	L	e	f	g	T		H	h	Min. Tensile Strength	Min. Tensile Strength	Avg. Tensile Strength	Max. Allowable Load													
DID	JIS	P																														
<b>DID40</b>	40				16.5	17.6	18.1	19.1											15.2	1,549	15.69	1,600	19.1	1,950	3.72	380	0.63					
<b>DID40-2</b>	40-2				31.0	32.1	32.6	33.6											30.4	3,098	31.38	3,200	38.2	3,900	6.27	640	1.19					
<b>DID40-3</b>	40-3	12.70	7.95	7.92	3.97	45.4	46.4	47.0	47.9	8.3	9.5	10.1	14.4	1.50	12.0	10.4			45.6	4,647	47.07	4,800	57.3	5,850	9.31	950	1.78					
<b>DID40-4</b>	40-4				59.9	61.0	61.4	61.4											60.8	6,196	62.76	6,400	76.4	7,800	12.2	1,250	2.37					
<b>DID40-5</b>	40-5				74.3	75.4	75.8	75.8											76.0	7,749	78.45	8,000	95.6	9,750	14.5	1,480	2.96					

Note: The values of average tensile strength and Max. allowable tension are for chains.

### Max. Kilowatt Ratings DID 40

Unit (kW)

No. of Teeth of Small Sprocket	Small sprocket rpm (Refer to P132 for the details of lubrication A, B and C.)																																																										
	50			200			400			600			900			1200			1800			2400			3000			3500			4000			4500			5000			5500			6000			6500			7000			7500			8000			9000	
Type of Lubrication	A						B						C																																														
11	0.20	0.70	1.30	1.88	2.71	3.51	3.48	2.26	1.62	1.28	1.05	0.88	0.75	0.65	0.57	0.51	0.45	0.41	0.37																																								
12	0.22	0.77	1.43	2.06	2.97	3.85	3.96	2.57	1.84	1.46	1.20	1.00	0.86	0.74	0.65	0.58	0.52	0.47	0.42																																								
13	0.24	0.84	1.56	2.25	3.24	4.20	4.47	2.90	2.08	1.65	1.35	1.13	0.97	0.84	0.73	0.65	0.58	0.53	0.48																																								
14	0.26	0.91	1.69	2.44	3.51	4.55	5.00	3.24	2.32	1.84	1.51	1.26	1.08	0.94	0.82	0.73	0.65	0.59	0.53																																								
15	0.28	0.98	1.82	2.63	3.78	4.90	5.54	3.60	2.57	2.04	1.67	1.40	1.20	1.04	0.91	0.81	0.72	0.65																																									
16	0.30	1.05	1.96	2.82	4.06	5.26	6.10	3.96	2.84	2.25	1.84	1.54	1.32	1.14	1.00	0.89	0.80	0.72																																									
17	0.32	1.12	2.09	3.01	4.33	5.61	6.68	4.34	3.11	2.47	2.02	1.69	1.44	1.25	1.10	0.97	0.87	0.79																																									
18	0.34	1.19	2.22	3.20	4.61	5.97	7.28	4.73	3.38	2.69	2.20	1.84	1.57	1.36	1.20	1.06	0.95	0.86																																									
19	0.36	1.26	2.35	3.39	4.89	6.33	7.90	5.13	3.67	2.91	2.38	2.00	1.71	1.48	1.30	1.15	1.03	0.93																																									
20	0.38	1.33	2.49	3.58	5.16	6.69	8.53	5.54	3.96	3.15	2.57	2.16	1.84	1.60	1.40	1.24	1.11	1.00																																									
21	0.40	1.41	2.62	3.78	5.44	7.05	9.18	5.96	4.27	3.38	2.77	2.32	1.98	1.72	1.51	1.34	1.20	1.08																																									
22	0.42	1.48	2.76	3.97	5.72	7.41	9.84	6.39	4.57	3.63	2.97	2.49	2.13	1.84	1.62	1.43	1.28																																										
23	0.45	1.55	2.89	4.17	6.00	7.78	10.5	6.83	4.89	3.88	3.18	2.66	2.27	1.97	1.73	1.53	1.37																																										
24	0.47	1.62	3.03	4.37	6.29	8.15	11.2	7.28	5.21	4.14	3.38	2.84	2.42	2.10	1.84	1.63	1.46																																										
25	0.49	1.70	3.17	4.56	6.57	8.51	11.9	7.74	5.54	4.40	3.60	3.02	2.57	2.23	1.96	1.74																																											
28	0.55	1.92	3.58	5.16	7.43	9.62	13.9	9.18	6.57	5.21	4.27	3.57	3.05	2.65	2.32	2.06																																											
30	0.59	2.07	3.86	5.55	8.00	10.4	14.9	10.2	7.28	5.78	4.73	3.96	3.38	2.93	2.57																																												
32	0.64	2.22	4.13	5.96	8.58	11.1	16.0	11.2	8.02	6.37	5.21	4.37	3.73	3.23	2.84																																												
35	0.70	2.44	4.55	6.56	9.45	12.2	17.6	12.8	9.18	7.28	5.96	5.00	4.27	3.70																																													
40	0.81	2.82	5.26	7.58	10.9	14.1	20.4	15.7	11.2	8.90	7.28	6.10	5.21																																														
45	0.92	3.20	5.98	8.61	12.4	16.1	23.1	18.7	13.4	10.6	8.69	7.28																																															

Note: Values in the above table are for simplex chain only. For multiplex chains, please multiply the coefficient of multi-strand. (See "Chain Selection" on P120).

# DID 40 Standard Sprocket

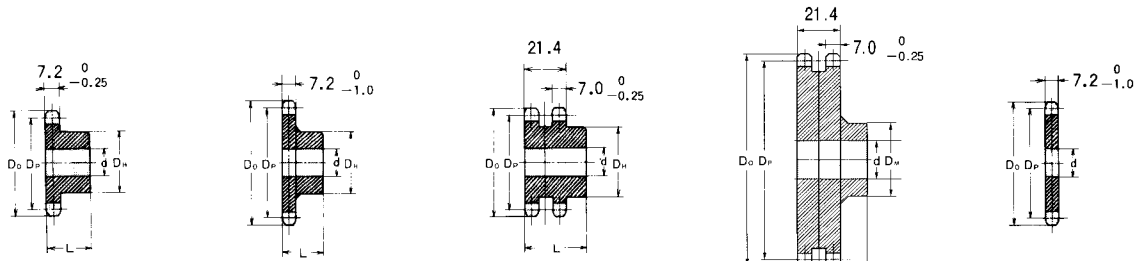

Single sprocket with hub on one side (Single B type)

Single sprocket with hub on one side (Single BW type Welded)

Double sprocket with hub on one side (Double B type)

Double sprocket with hub on one side (Double BW type Welded)

Flat plain (A type)

Unit (mm)

Number of teeth	Pitch dia. DP	Tip dia. DO	Single sprocket with hub on one side (B type/ BW type)						Double sprocket with hub on one side (B type/ BW type)						Flat plain (A type)			Number of teeth
			Bore d		Hub		Approx. weight (Kg)	Material	Bore d		Hub		Approx. weight (Kg)	Material	Stock d	Approx. weight (Kg)	Material	
			Stock	Max.	(Dia.)	DH			(Length) L	Stock	Max.	(Dia.)						
9	37.13	42	9	15	28*	22	0.11							9			9	
10	41.10	46	9	16	32*	22	0.14							9	0.05		10	
11	45.08	51	10	20	37*	22	0.19							10	0.06		11	
12	49.07	53	10	22	40*	22	0.22		13	18	32	35	0.34	10	0.10		12	
13	53.07	58	13	20	37	22	0.23		14	20	37	35	0.39	13	0.10		13	
14	57.07	63	13	24	42	22	0.28		14	24	42	35	0.47	13	0.11		14	
15	61.08	67	13	28	46	22	0.34		14	28	46	35	0.56	13	0.15		15	
16	65.10	71	13	30	50	22	0.40		14	30	50	35	0.65	13	0.17		16	
17	69.12	75	13	32	54	22	0.46		14	32	54	35	0.75	13	0.20		17	
18	73.14	78	13	35	57	22	0.51		14	35	57	35	0.85	13	0.20		18	
19	77.16	83	13	39	62	22	0.59		14	39	62	35	0.98	13	0.26		19	
20	81.18	88	14	45	67	25	0.76		14	45	67	40	1.30	14	0.26		20	
21	85.21	92	14	45	71	25	0.85		14	47	71	40	1.40	14	0.30		21	
22	89.24	96	14	50	75	25	0.95	S35C	14	50	75	40	1.60	14	0.30		22	
23	93.27	98	14	50	77	25	1.00		14	50	77	40	1.70	14	0.35		23	
24	97.30	104	14	42	63	25	0.81		14	55	83	40	1.90	14	0.37		24	
25	101.33	108	14	42	63	25	0.88		18	59	87	40	2.10	14	0.40		25	
26	105.36	112	14	42	63	25	0.92		18	62	91	40	2.30	14	0.35		26	
27	109.40	116	14	42	63	25	0.96							14	0.50		27	
28	113.43	120	14	42	63	25	1.00							14	0.51		28	
29	117.46	124	14	42	63	25	1.10							14	0.51		29	
30	121.50	128	14	42	63	25	1.10		18	73	106	40	3.00	14	0.60		30	
31	125.53	132	14	45	63	25	1.20							14	0.61	SS400	31	
32	129.57	137	14	45	68	28	1.30							14	0.68		32	
33	133.61	140	14	45	68	28	1.30							14	0.70		33	
34	137.64	145	14	45	68	28	1.30							14	0.75		34	
35	141.68	149	14	45	68	28	1.40		17	55	83	50	3.10	14	0.83		35	
36	145.72	153	17	45	67	28	1.40							17	0.90		36	
37	149.75	157	17	45	67	28	1.50							17	0.93		37	
38	153.79	161	17	45	67	28	1.50							17	0.95		38	
39	157.83	165	17	45	67	28	1.60							17	1.05		39	
40	161.87	169	17	45	67	28	1.60		17	55	83	50	3.60	17	1.06		40	
41	165.91	173	17	45	72	32	1.70							17	1.15		41	
42	169.95	177	17	48	72	32	2.00							17	1.20		42	
43	173.98	181	17	48	72	32	2.10							17	1.23		43	
44	178.02	185	17	48	72	32	2.20							17	1.30		44	
45	182.06	189	17	48	72	32	2.20	SS400 Welded						17	1.36		45	
48	194.18	201	17	48	72	32	2.30		17	63	93	50	4.60	17	1.53		48	
50	202.26	209	17	48	72	32	2.40							17	1.70		50	
54	218.42	226	17	48	72	32	2.80		17	63	93	50	5.80	17	2.00	SS400 Welded	54	
60	242.66	250	17	48	72	32	3.20		17	63	93	50	6.70	17	2.50		60	
65	262.87	270	17	55	82	32	3.90							17	2.87		65	
70	283.07	290	19	55	82	32	4.30							19	3.30		70	
72	291.16	299	19	55	82	32	4.80							19	3.40		72	
75	303.28	311	19	55	82	32	5.00							19	4.50		75	

- Note: 1. Determine the required bore size less than the Max. value shown above taking strength reduction into consideration.  
 2. The shaded area of the above table indicates heat treated teeth.  
 3. Due to material availability and production reasons, forged S35C may be used for teeth portion and SS400 for hub and welded for double sprockets with 31 ~ 40 teeth without notice.  
 4. Those marked \* have slot on hub.

## DID 50 standard roller chain

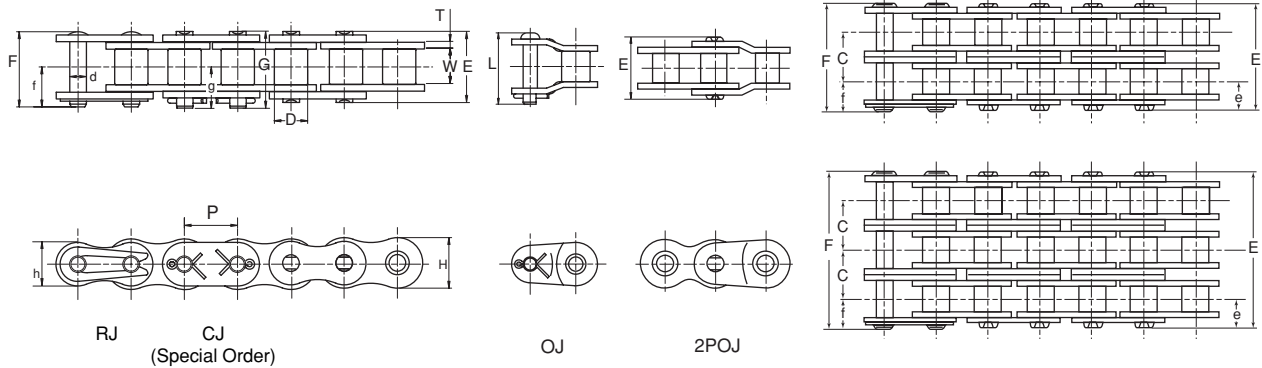

### Dimensions

Unit (mm)

Chain No.		Pitch P	Roller Link Width W	Roller dia. D	Pin							Transverse Pitch C	Plate			JIS		DID		DID		Approx. Weight (kg/m)			
DID	JIS				d	E	F	G	L	e	f		g	T	H	h	Min. Tensile Strength	Min. Tensile Strength	Avg. Tensile Strength	Max. Allowable Load					
														kN	kgf	kN	kgf	kN	kgf						
<b>DID50</b>	50				20.3	21.9	22.1	23.2							24	2,447	26.48	2,700	30.8	3,150	6.86	700	1.06		
<b>DID50-2</b>	50-2				38.5	40.1	40.3	41.3							48	4,894	52.96	5,400	61.7	6,300	11.6	1,190	2.04		
<b>DID50-3</b>	50-3	15.875	9.53	10.16	5.09	56.7	58.3	58.5	59.5	10.2	11.6	12.1	18.1	2.00	15.0	13.0	72	7,341	79.44	8,100	92.6	9,450	17.1	1,750	3.06
<b>DID50-4</b>	50-4				74.8	76.4	76.6	76.6							96	9,788	105.9	10,800	123	12,600	22.6	2,310	4.06		
<b>DID50-5</b>	50-5				93.0	94.5	94.7	94.7							120	12,236	132.4	13,500	155	15,750	26.7	2,730	5.08		

Note: The values of average tensile strength and Max. allowable tension are for chains.

### Max. Kilowatt Ratings DID 50

Unit (kW)

No. of Teeth of Small Sprocket	Small Sprocket revolutions per minute (rpm) (See P132 for the details of type of lubrication A, B and C.)																								
	50					100					300					500					900				
	A					B					C														
11	0.48	0.90	2.42	3.83	6.49	7.64	5.47	4.16	3.30	2.70	2.26	1.93	1.68	1.53	1.26	1.05	0.09	0.80	0.72						
12	0.53	0.99	2.65	4.20	7.13	8.71	6.23	4.74	3.76	3.08	2.58	2.20	1.91	1.75	1.43	1.20	1.02	0.91	0.82						
13	0.58	1.08	2.89	4.58	7.78	9.82	7.02	5.34	4.24	3.47	2.91	2.48	2.15	1.97	1.61	1.35	1.15	1.03	0.92						
14	0.63	1.17	3.14	4.96	8.43	10.9	7.85	5.97	4.74	3.88	3.25	2.78	2.41	2.20	1.80	1.51	1.29	1.15							
15	0.67	1.26	3.38	5.35	9.08	11.8	8.71	6.62	5.26	4.30	3.61	3.08	2.67	2.44	2.00	1.68	1.43	1.27							
16	0.72	1.35	3.62	5.74	9.73	12.6	9.59	7.30	5.79	4.74	3.97	3.39	2.94	2.69	2.20	1.85	1.58	1.40							
17	0.77	1.44	3.87	6.12	10.4	13.5	10.5	7.99	6.34	5.19	4.35	3.71	3.22	2.95	2.41	2.02	1.73	1.54							
18	0.82	1.53	4.11	6.51	11.1	14.3	11.4	8.71	6.91	5.65	4.74	4.05	3.51	3.21	2.63	2.20	1.88								
19	0.87	1.62	4.36	6.90	11.7	15.2	12.4	9.44	7.49	6.13	5.14	4.39	3.80	3.48	2.85	2.39	2.04								
20	0.92	1.71	4.61	7.30	12.4	16.1	13.4	10.2	8.09	6.62	5.55	4.74	4.11	3.76	3.08	2.58	2.20								
21	0.97	1.81	4.86	7.69	13.1	16.9	14.4	11.0	8.71	7.13	5.97	5.10	4.42	4.05	3.31	2.78	2.37								
22	1.02	1.90	5.11	8.09	13.7	17.8	15.5	11.8	9.34	7.64	6.40	5.47	4.74	4.34	3.55	2.98	2.54								
23	1.07	1.99	5.36	8.49	14.4	18.7	16.5	12.6	9.98	8.17	6.84	5.84	5.07	4.64	3.80	3.18									
24	1.12	2.09	5.61	8.89	15.1	19.5	17.6	13.4	10.6	8.71	7.30	6.23	5.40	4.94	4.05	3.39									
25	1.17	2.18	5.86	9.29	15.8	20.4	18.7	14.3	11.3	9.26	7.76	6.62	5.74	5.26	4.30	3.61									
28	1.32	2.47	6.63	10.5	17.8	23.1	22.2	16.9	13.4	11.0	9.19	7.85	6.80	6.23	5.10										
30	1.42	2.66	7.14	11.3	19.2	24.9	24.6	18.7	14.9	12.2	10.2	8.71	7.55	6.91	5.65										
32	1.53	2.85	7.66	12.1	20.6	26.7	27.1	20.6	16.4	13.4	11.2	9.59	8.31	7.61	6.23										
35	1.68	3.14	8.43	13.4	22.7	29.4	31.0	23.6	18.7	15.3	12.9	11.0	9.51	8.71	7.13										
40	1.94	3.62	9.74	15.4	26.2	33.9	37.9	28.8	22.9	18.7	15.7	13.4	11.6	10.6											
45	2.21	4.12	11.1	17.5	29.7	38.5	45.2	34.4	27.3	22.4	18.7	16.0	13.9												

Note: Values in the table above are for simplex chain only. For multiplex chains, please multiply the coefficient of multi-strand. (See "Chain Selection" on P120).

# DID 50 Standard Sprocket

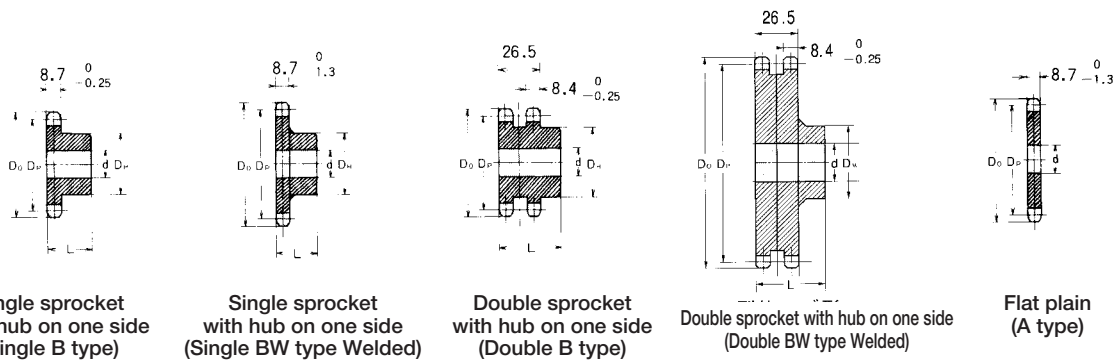

Unit (mm)

Number of teeth	Pitch dia. DP	Tip dia. Do	Single sprocket with hub on one side (B type/ BW type)						Double sprocket with hub on one side (B type/ BW type)						Flat plain (A type)			Number of teeth
			Bore d		Hub		Approx. weight (Kg)	Material	Bore d		Hub		Approx. weight (Kg)	Material	Stock d	Approx. weight (Kg)	Material	
			Stock	Max.	(Dia.)	DH			(Length) L	Stock	Max.	(Dia.)						
9	46.21	53	10	19	34*	25	0.20								10			9
10	51.38	58	10	22	40*	25	0.27								10	0.11		10
11	56.35	63	13	24	46*	25	0.33								13	0.15		11
12	61.34	68	13	32	51*	25	0.41		14	24	42	40	0.60		13	0.18		12
13	66.34	73	13	32	51*	25	0.46		14	28	47	40	0.73		13	0.18		13
14	71.34	79	13	32	52	25	0.52		14	32	52	40	0.87		13	0.20		14
15	76.35	84	13	35	57	25	0.62		14	35	57	40	1.00		13	0.26		15
16	81.37	89	13	40	62	25	0.72		14	39	62	45	1.30		13	0.30		16
17	86.39	94	13	45	67	25	0.83		14	45	67	45	1.50		13	0.35		17
18	91.42	99	13	47	72	28	1.00		14	47	72	45	1.70		13	0.40		18
19	96.45	104	13	47	73	28	1.10		14	52	79	45	2.00		13	0.44		19
20	101.48	109	14	47	73	28	1.20		18	55	82	45	2.20		14	0.50		20
21	106.51	114	14	47	73	28	1.20		18	60	89	45	2.50		14	0.54		21
22	111.55	119	16	47	73	28	1.30	S35C	18	63	92	50	2.90		16	0.59		22
23	116.58	124	16	47	73	28	1.30		18	67	99	50	3.30		16	0.65		23
24	121.62	129	16	47	73	28	1.40		18	70	102	50	3.60		16	0.70		24
25	126.66	134	16	47	73	28	1.50		18	75	109	50	4.00	S35C	16	0.80		25
26	131.70	139	16	48	73	28	1.50		18	63	93	50	3.40		16	0.85		26
27	136.74	144	16	48	73	28	1.50								16	0.90		27
28	141.79	149	16	48	73	28	1.60								16	1.00		28
29	146.83	154	16	48	73	28	1.60								16	1.10		29
30	151.87	160	16	48	73	28	1.70		18	63	93	50	4.00		16	1.15		30
31	156.92	165	16	48	73	28	1.80								16	1.20	SS400	31
32	161.96	170	16	48	73	28	1.80								16	1.26		32
33	167.01	175	16	48	73	28	1.90								16	1.35		33
34	172.05	180	16	48	73	28	2.10								16	1.45		34
35	177.10	185	16	48	73	28	2.20		18	63	93	50	4.80		16	1.55		35
36	182.14	191	19	55	82	35	2.70								19	1.67		36
37	187.19	196	19	55	82	35	2.80								19	1.80		37
38	192.24	201	19	55	82	35	2.90								19	1.85		38
39	197.29	206	19	55	82	35	2.90								19	2.00		39
40	202.33	211	19	55	82	35	3.10		19	66	98	56	6.20		19	2.05		40
41	207.38	216	19	55	82	35	3.20								19	2.12		41
42	212.43	221	19	55	82	35	3.30								19	2.30		42
43	217.48	226	19	55	82	35	3.40								19	2.43		43
44	222.53	231	19	55	82	35	3.50								19	2.60		44
45	227.58	237	19	55	82	35	3.60								19	2.60		45
48	242.73	252	19	55	82	35	4.00		19	66	98	56	7.30		19	3.00		48
50	252.83	262	19	55	82	35	4.30								19	3.30		50
54	273.02	282	19	55	82	35	4.80		19	66	98	63	9.90	SS400 Welded	19	3.90		54
60	303.33	312	19	55	82	35	5.60		19	66	98	63	11.70		19	4.80		60
65	328.58	338	19	63	92	40	6.90								19	5.80		65
70	353.84	363	20	63	92	40	7.70								20	6.35		70
72	363.94	373	20	63	92	40									20	6.60		72
75	379.10	388	20	63	92	40	8.60								20	7.00		75

- Note: 1. Determine the required bore size less than the Max. value shown above taking strength reduction into consideration.  
 2. The shaded area of the above table indicates heat treated teeth.  
 3. Due to material availability and production reasons, forged S35C may be used for teeth portion and SS400 for hub and welded for double sprockets with 26 ~ 31 teeth without notice.  
 4. Those marked \* have slot on hub.



## DID 60 standard roller chain

Roller Chains for Power Transmission

Standard Roller Chain

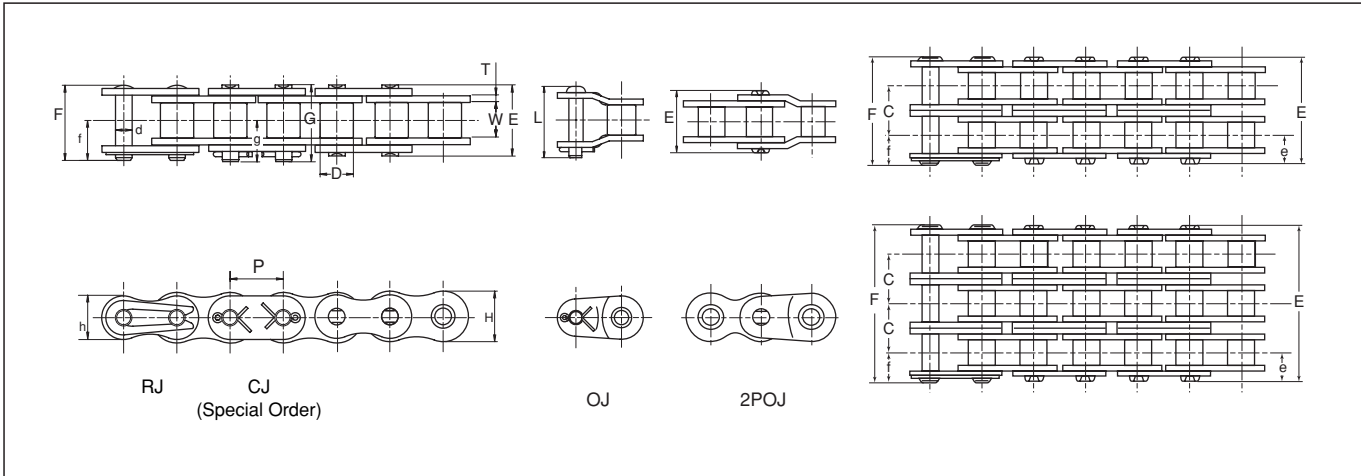

### Dimensions

Unit (mm)

Chain No.	Pitch	Roller Link Width W	Roller dia. D	Pin									Transverse Pitch C	Plate				JIS		DID		DID		Approx. Weight (kg/m)									
				d	E	F	G	L	e	f	g	T		H	h	Min. Tensile Strength	Min. Tensile Strength	Avg. Tensile Strength	Max. Allowable Load														
DID	JIS	P																															
<b>DID60</b>	60				25.4	26.9	27.9	29.8											34.2	3,487	35.30	3,600	44.1	4,500	9.31	950	1.44						
<b>DID60-2</b>	60-2				48.3	49.8	50.9	52.5											68.4	6,974	70.60	7,200	88.2	9,000	15.7	1,610	3.03						
<b>DID60-3</b>	60-3	19.05	12.70	11.91	5.96	71.2	72.7	73.7	75.3	12.7	14.3	15.1	22.8	2.40	18.1	15.6			102.6	10,461	105.9	10,800	132	13,500	23.2	2,370	4.51						
<b>DID60-4</b>	60-4				94.0	95.5	96.5	96.5											136.8	13,948	141.2	14,400	176	18,000	30.6	3,130	6.03						
<b>DID60-5</b>	60-5				116.8	118.8	119.3	119.3											171.0	17,435	176.5	18,000	220	22,500	36.2	3,700	7.53						

Note: The values of average tensile strength and Max. allowable tension are for chains.

### Max. Kilowatt Ratings DID 60

Unit (kW)

Type of Lubrication No. of Teeth of Small Sprocket	Small Sprocket revolutions per minute (rpm) (See P132 for the details of type of lubrication A, B and C.)																																																																															
	50				100				200				500				700				900				1200				1400				1600				1800				2000				2200				2400				2600				2800				3000				3500				3800				4000				4600			
	A				B				C				A				B				C				A				B				C				A				B				C				A				B				C																							
11	0.75	1.40	2.62	5.98	8.09	10.2	8.84	7.02	5.74	4.81	4.11	3.56	3.13	2.77	2.48	2.24	1.77	1.57	1.45																																																													
12	0.83	1.54	2.88	6.57	8.89	11.2	10.1	7.99	6.54	5.48	4.68	4.06	3.56	3.16	2.83	2.55	2.02	1.79	1.66																																																													
13	0.90	1.68	3.14	7.16	9.69	12.2	11.4	9.01	7.38	6.18	5.28	4.58	4.02	3.56	3.19	2.87	2.28	2.02	1.87																																																													
14	0.98	1.82	3.40	7.76	10.5	13.2	12.7	10.1	8.24	6.91	5.90	5.11	4.49	3.98	3.56	3.21	2.55	2.25	2.09																																																													
15	1.05	1.96	3.66	8.36	11.3	14.2	14.1	11.2	9.14	7.66	6.54	5.67	4.98	4.41	3.95	3.56	2.83	2.50	2.31																																																													
16	1.13	2.11	3.93	8.96	12.1	15.2	15.5	12.3	10.1	8.44	7.21	6.25	5.48	4.86	4.35	3.92	3.11	2.75	2.55																																																													
17	1.20	2.25	4.19	9.57	13.0	16.2	17.0	13.5	11.0	9.25	7.89	6.84	6.01	5.33	4.77	4.30	3.41	3.01	2.79																																																													
18	1.28	2.39	4.46	10.2	13.8	17.3	18.5	14.7	12.0	10.1	8.60	7.45	6.54	5.80	5.19	4.68	3.72	3.28	3.04																																																													
19	1.36	2.53	4.73	10.8	14.6	18.3	20.1	15.9	13.0	10.9	9.33	8.08	7.10	6.29	5.63	5.08	4.03	3.56	3.30																																																													
20	1.44	2.68	5.00	11.4	15.4	19.4	21.7	17.2	14.1	11.8	10.1	8.73	7.66	6.80	6.08	5.48	4.35	3.85																																																														
21	1.51	2.82	5.27	12.0	16.3	20.4	23.3	18.5	15.2	12.7	10.8	9.39	8.24	7.31	6.54	5.90	4.68	4.14																																																														
22	1.59	2.97	5.54	12.6	17.1	21.5	25.0	19.9	16.2	13.6	11.6	10.1	8.84	7.84	7.02	6.33	5.02	4.44																																																														
23	1.67	3.12	5.81	13.3	18.0	22.5	26.7	21.2	17.4	14.6	12.4	10.8	9.45	8.38	7.50	6.76	5.37																																																															
24	1.75	3.26	6.09	13.9	18.8	23.6	28.5	22.6	18.5	15.5	13.2	11.5	10.1	8.93	7.99	7.21	5.72																																																															
25	1.83	3.41	6.36	14.5	19.6	24.6	30.3	24.0	19.7	16.5	14.1	12.2	10.7	9.50	8.50	7.66	6.08																																																															
28	2.06	3.85	7.19	16.4	22.2	27.8	35.9	28.5	23.3	19.5	16.7	14.5	12.7	11.3	10.1	9.08	7.21																																																															
30	2.22	4.15	7.75	17.7	23.9	30.0	38.9	31.6	25.9	21.7	18.5	16.0	14.1	12.5	11.2	10.1																																																																
32	2.38	4.45	8.30	18.9	25.6	32.2	41.7	34.8	28.5	23.9	20.4	17.7	15.5	13.8	12.3	11.1																																																																
35	2.63	4.90	9.15	20.9	28.3	35.4	45.9	39.8	32.6	27.3	23.3	20.2	17.7	15.7	14.1	12.7																																																																
40	3.03	5.66	10.6	24.1	32.6	40.9	53.0	48.7	39.8	33.4	28.5	24.7	21.7	19.2	17.2																																																																	
45	3.45	6.43	12.0	27.4	37.1	46.5	60.2	58.1	47.5	39.8	34.0	29.5	25.9	22.9																																																																		

Note: Values in the table above are for simplex chain only. For multiplex chains, please multiply the coefficient of multi-strand. (See "Chain Selection" on P120).



# DID 60 Standard Sprocket

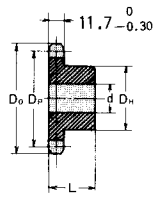

Single sprocket with hub on one side (Single B type)

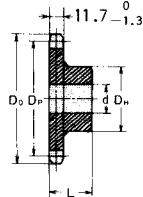

Single sprocket with hub on one side (Single BW type Welded)

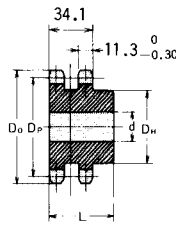

Double sprocket with hub on one side (Double B type)

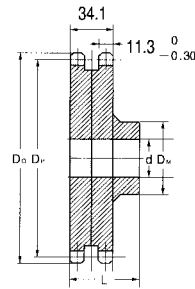

Double sprocket with hub on one side (Double BW type Welded)

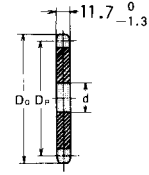

Flat plain (A type)

Unit (mm)

Number of teeth	Pitch dia. DP	Tip dia. DO	Single sprocket with hub on one side (B type/ BW type)						Double sprocket with hub on one side (B type/ BW type)						Flat plain (A type)			Number of teeth	
			Bore d		Hub		Approx. weight (Kg)	Material	Bore d		Hub		Approx. weight (Kg)	Material	Stock d	Approx. weight (Kg)	Material		
			Stock	Max.	(Dia.) DH	(Length) L			Stock	Max.	(Dia.) DH	(Length) L							
9	55.70	63	10	24	43*	32	0.40												9
10	61.65	68	14	30	49*	32	0.49												10
11	67.62	76	14	32	51*	32	0.60												11
12	73.60	82	14	32	51	32	0.69		16	32	51	50	1.10		14	0.26			12
13	79.60	88	14	35	57	32	0.81		18	35	57	50	1.30		14	0.30			13
14	85.61	93	16	39	62	32	0.96		18	39	62	56	1.70		16	0.37			14
15	91.62	99	16	45	68	32	1.10		18	45	68	56	2.00		16	0.43			15
16	97.65	107	16	47	73	32	1.30		18	50	76	56	2.40		16	0.51			16
17	103.67	113	16	47	73	32	1.40		18	55	82	56	2.80		16	0.60			17
18	109.71	119	16	55	83	40	2.00		18	59	87	56	3.10		16	0.68			18
19	115.74	126	16	55	83	40	2.10		18	59	87	56	3.10		16	0.75			19
20	121.78	132	16	55	83	40	2.20	S35C	20	63	95	56	3.60		16	0.88			20
21	127.82	138	16	55	83	40	2.31		20	69	101	56	4.10		16	0.96			21
22	133.86	144	16	55	83	40	2.43		20	75	107	56	4.50		16	1.10			22
23	139.90	150	16	55	83	40	2.50		20	78	113	56	5.00	S35C	16	1.15			23
24	145.95	156	16	55	83	40	2.50		20	66	98	56	4.60		16	1.20			24
25	151.99	162	16	55	83	40	2.70		20	66	98	56	4.80		16	1.40			25
26	158.04	168	16	55	83	40	2.90		20	66	98	56	5.00		16	1.51			26
27	164.09	174	16	55	83	40	3.00		20	66	98	56	5.00		16	1.65			27
28	170.14	180	16	55	83	40	3.10		20	66	98	56	5.00		16	1.70			28
29	176.20	186	16	55	83	40	3.30		20	66	98	56	5.00		16	1.90			29
30	182.25	193	20	55	83	40	3.40		20	66	98	56	6.50		16	2.05			30
31	188.30	199	20	55	83	40	3.50		20	66	98	56	6.50		20	2.25			31
32	194.35	205	20	55	83	40	3.70		20	66	98	56	7.80		20	2.40	SS400		32
33	200.41	211	20	55	83	40	3.80		20	66	98	56	7.80		20	2.55			33
34	206.46	217	20	55	83	40	4.00		20	66	98	56	7.80		20	2.70			34
35	212.52	223	20	55	83	40	4.20		20	66	98	56	7.80		20	2.90			35
36	218.57	229	20	55	83	40	4.40		20	66	98	56	7.80		20	3.12			36
37	224.63	236	20	55	83	40	4.60		20	66	98	56	9.70		20	3.21			37
38	230.69	241	20	55	83	40	4.80		20	66	98	56	9.70		20	3.45			38
39	236.74	248	20	55	83	40	4.90		20	66	98	56	9.70		20	3.56			39
40	242.80	253	20	55	83	40	5.10		20	66	98	56	9.70		20	3.83			40
41	248.86	260	20	63	93	45	5.50		20	66	98	56	9.70		20	4.05			41
42	254.92	266	20	63	93	45	6.00	SS400 Welded	20	66	98	56	9.70		20	4.22			42
43	260.98	272	20	63	93	45	6.20		20	66	98	56	9.70		20	4.37			43
44	267.03	278	20	63	93	45	6.40		20	66	98	56	9.70		20	4.61			44
45	273.09	284	20	63	93	45	6.70		20	66	98	56	9.70		20	4.89			45
48	291.27	302	20	63	93	45	7.40		20	75	107	71	12.80	SS400 Welded	20	5.68			48
50	303.39	314	20	63	93	45	7.80		20	75	107	71	12.80		20	5.75			50
54	327.63	338	20	63	93	45	8.80		20	75	107	71	18.00		20	6.25			54
60	363.99	375	20	63	93	45	10.60		20	75	107	71	21.50		20	7.25			60
65	394.30	405	20	75	107	45	12.80		20	75	107	71	21.50		20	9.00			65
70	424.61	436	20	75	107	45	14.40		20	75	107	71	21.50		20	10.60			70
72	436.73	448	20	75	107	45	14.40		20	75	107	71	21.50		20	12.20			72
75	454.92	466	20	75	107	45	16.30		20	75	107	71	21.50		20	12.50			75

- Note: 1. Determine the required bore size less than the Max. value shown above taking strength reduction into consideration.  
 2. The shaded area of the above table indicates heat treated teeth.  
 3. Due to material availability and production reasons, forged S35C may be used for teeth portion and SS400 for hub and welded for double sprockets with 23 ~ 35 teeth without notice.  
 4. Those marked \* have slot on hub.

## DID 80 standard roller chain

Roller Chains for Power Transmission  
Standard Roller Chain

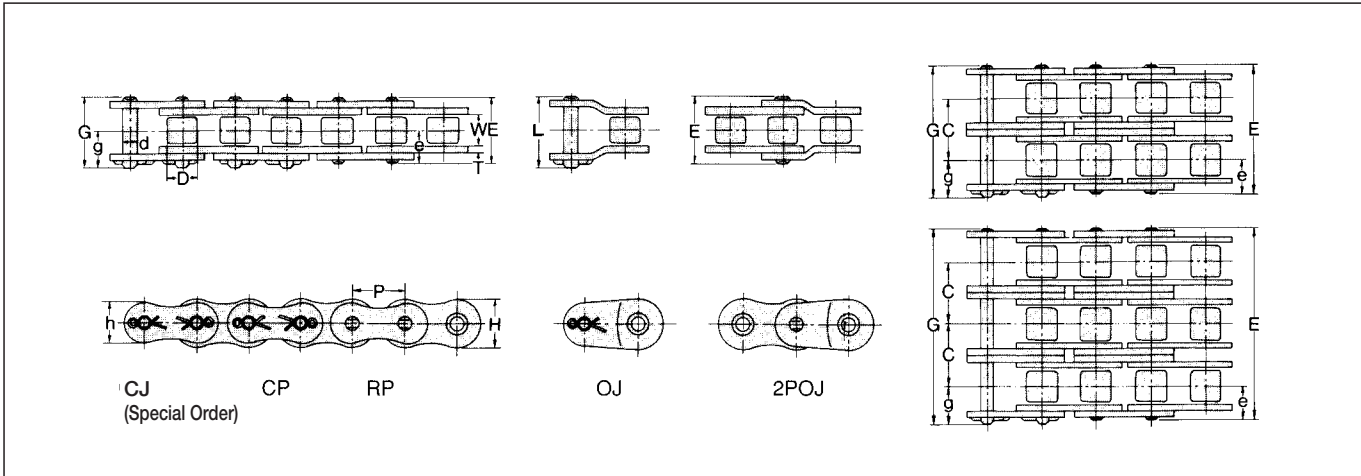

### Dimensions

Unit (mm)

Chain No.	Pitch	Roller Link Width	Roller dia.	Pin						Transverse Pitch	Plate			JIS		DID		DID		Approx. Weight (kg/m)			
				d	E	G	L	e	g		C	T	H	h	Min. Tensile Strength	Min. Tensile Strength	Avg. Tensile Strength	Max. Allowable Load					
DID	JIS	P	W	D	d	E	G	L	e	g	C	T	H	h	kN	kgf	kN	kgf	kN	kgf			
<b>DID80</b>	80					32.5	35.5	37.1							61.2	6,240	71.59	7,300	78.4	8,000	14.7	1,500	2.55
<b>DID80-2</b>	80-2					61.8	64.7	66.3							122.4	12,480	143.1	14,600	156	16,000	25.0	2,550	5.07
<b>DID80-3</b>	80-3	25.40	15.88	15.88	7.94	91.3	94.0	95.1	16.3	19.25	29.3	3.20	24.1	20.8	183.6	18,720	214.7	21,900	235	24,000	36.7	3,750	7.58
<b>DID80-4</b>	80-4					120.6	123.3	124.4							244.8	24,960	286.3	29,200	313	32,000	48.5	4,950	10.1
<b>DID80-5</b>	80-5					149.9	152.6	153.7							306.0	31,200	357.9	36,500	392	40,000	57.3	5,850	12.6

Note: The values of average tensile strength and Max. allowable tension are for chains.

### Max. Kilowatt Ratings DID 80

Unit (kW)

No. of Teeth of Small Sprocket	Small Sprocket revolutions per minute (rpm) (See P132 for the details of type of lubrication A, B and C.)																																				
	Type of Lubrication			20	50	100	200	300	400	500	700	900	1000	1200	1400	1600	1800	2000	2200	2400	2600	2700	2800	3000	3200	3400	3600	3800									
	A			B												C																					
11	1.13	2.12	3.95	7.37	10.6	13.8	16.8	22.8	17.1	14.6	11.1	8.83	7.23	6.06	5.17	4.48	3.93	3.49	3.30	3.12	2.82	2.56	2.33														
12	1.25	2.33	4.34	8.10	11.7	15.1	18.5	25.0	19.5	16.7	12.7	10.1	8.24	6.90	5.89	5.11	4.48	3.98	3.76	3.56	3.21	2.91	2.66														
13	1.36	2.54	4.73	8.83	12.7	16.5	20.1	27.3	22.0	18.8	14.3	11.4	9.29	7.78	6.64	5.76	5.05	4.48	4.24	4.01	3.62	3.28	3.00														
14	1.47	2.75	5.13	9.56	13.8	17.9	21.8	29.5	24.6	21.0	16.0	12.7	10.4	8.70	7.43	6.44	5.65	5.01	4.73	4.48	4.04	3.67	3.35														
15	1.59	2.96	5.52	10.3	14.8	19.2	23.5	31.8	27.3	23.3	17.7	14.1	11.5	9.65	8.24	7.14	6.27	5.56	5.25	4.97	4.48	4.07															
16	1.70	3.17	5.92	11.1	15.9	20.6	25.2	34.1	30.1	25.7	19.5	15.5	12.7	10.6	9.07	7.86	6.90	6.12	5.78	5.48	4.94	4.48															
17	1.82	3.39	6.32	11.8	17.0	22.0	26.9	36.4	32.9	28.1	21.4	17.0	13.9	11.6	9.94	8.61	7.56	6.70	6.34	6.00	5.41	4.91															
18	1.93	3.60	6.72	12.6	18.1	23.4	28.6	38.7	35.9	30.6	23.3	18.5	15.1	12.7	10.8	9.38	8.24	7.30	6.90	6.54	5.89	5.35															
19	2.05	3.82	7.13	13.3	19.2	24.8	30.3	41.1	38.9	33.2	25.3	20.1	16.4	13.8	11.7	10.2	8.93	7.92	7.49	7.09	6.39																
20	2.16	4.04	7.33	14.1	20.3	26.2	32.1	43.4	42.0	35.9	27.3	21.7	17.7	14.9	12.7	11.0	9.65	8.55	8.08	7.65	6.90																
21	2.28	4.26	7.94	14.8	21.4	27.7	33.8	45.8	45.2	38.6	29.4	23.3	19.1	16.0	13.6	11.8	10.4	9.20	8.70	8.24	7.43																
22	2.40	4.48	8.35	15.6	22.5	29.1	35.6	48.1	48.5	41.4	31.5	25.0	20.4	17.1	14.6	12.7	11.1	9.87	9.33	8.83	7.96																
23	2.52	4.70	8.76	16.4	23.6	30.5	37.3	50.5	51.8	44.2	33.7	26.7	21.9	18.3	15.6	13.6	11.9	10.6	9.97	9.44	8.66																
24	2.63	4.92	9.17	17.1	24.7	31.9	39.1	52.9	55.2	47.2	35.9	28.5	23.3	19.5	16.7	14.5	12.7	11.3	10.6	10.1																	
25	2.75	5.14	9.59	17.9	25.8	33.4	40.8	55.2	58.7	50.1	38.1	30.3	24.8	20.8	17.7	15.4	13.5	12.0	11.3	10.7																	
28	3.11	5.81	10.8	20.2	29.1	37.7	46.1	62.4	69.6	59.4	45.2	35.9	29.4	24.6	21.0	18.2	16.0	14.2	13.4																		
30	3.35	6.26	11.7	21.9	31.4	40.1	49.7	67.3	77.2	65.9	50.1	39.8	32.6	27.3	23.3	20.2	17.7	15.7	15.7	6.03																	
32	3.59	6.71	12.5	23.4	33.6	43.6	53.3	72.1	85.0	72.6	55.2	43.8	35.9	30.1	25.7	22.2	19.5																				
35	3.96	7.39	13.8	25.7	37.1	48.0	58.7	79.5	97.2	83.0	63.2	50.4	41.0	34.4	29.4	25.4																					
40	4.57	8.54	15.9	29.7	42.8	55.5	67.8	91.8	115	101	77.2	61.2	50.1	42.0	35.9																						
45	5.19	9.69	18.1	33.8	48.6	63.0	77.0	104	131	121	92.1	73.1	59.8	50.1																							

Note: 1. Values in the table above are for simplex chain only. For multiplex chains, please multiply the coefficient of multi-strand. (See "Chain Selection" on P120).  
2. Consult us when the ratings beyond the dotted line to rightward.

# DID 80 Standard Sprocket

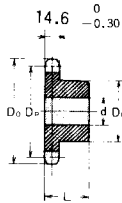

Single sprocket with hub on one side (Single B type)

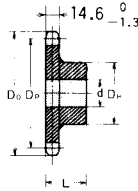

Single sprocket with hub on one side (Single BW type Welded)

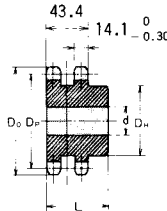

Double sprocket with hub on one side (Double B type)

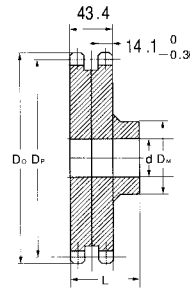

Double sprocket with hub on one side (Double BW type Welded)

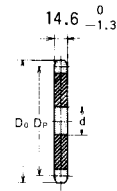

Flat plain (A type)

Unit (mm)

Number of teeth	Pitch dia. DP	Tip dia. Do	Single sprocket with hub on one side (B type/ BW type)						Double sprocket with hub on one side (B type/ BW type)						Flat plain (A type)			Number of teeth
			Bore d		Hub		Approx. weight (Kg)	Material	Bore d		Hub		Approx. weight (Kg)	Material	Stock d	Approx. weight (Kg)	Material	
			Stock	Max.	(Dia.)	DH			(Length) L	Stock	Max.	(Dia.)						
9	74.27	85	11	35	58*	40	0.87							11			9	
10	82.19	93	17	32	52	40	0.97							17	0.58		10	
11	90.16	101	17	38	60	40	1.20							17	0.62		11	
12	98.14	110	17	45	67	40	1.50							17	0.55		12	
13	106.14	118	17	48	77	40	1.90							17	0.87		13	
14	114.15	126	17	50	77	40	2.00							17	1.02		14	
15	122.17	134	20	63	93	40	2.59	S35C	23	64	93	63	4.30	S35C	20	1.20		15
16	130.20	142	20	63	93	40	2.78		23	70	102	71	5.50		20	1.35		16
17	138.23	151	20	63	93	40	3.00		23	76	110	71	6.40		20	1.54		17
18	146.27	159	20	63	93	40	3.20		23	66	98	71	6.00		20	1.75		18
19	154.32	167	20	63	93	40	3.40		23	66	98	71	6.50		20	1.95		19
20	162.37	175	20	63	93	40	3.60		23	75	107	71	7.60		20	2.15		20
21	170.42	183	20	63	93	40	3.80		23	75	107	71	7.80		20	2.41		21
22	178.48	192	20	75	107	45	4.80		20	80	117	71	8.80		20	2.63		22
23	186.54	200	20	75	107	45	5.10		20	80	117	71	9.30		20	2.90		23
24	194.60	208	20	75	107	45	5.40		20	80	117	80	10.50		20	3.20		24
25	202.66	216	20	75	107	45	5.60		20	80	117	80	11.10		20	3.45		25
26	210.72	224	20	75	107	45	5.90		20	80	117	80	11.70		20	3.70		26
27	218.79	233	20	75	107	45	6.10							20	3.96		27	
28	226.86	241	20	75	107	45	6.50							20	4.26		28	
29	234.93	249	20	75	107	45	6.90							20	4.65		29	
30	243.00	257	20	75	107	45	7.10		20	80	117	80	14.20		20	5.00		30
31	251.07	265	20	75	107	45	7.40							20	5.30	SS400	31	
32	259.14	273	20	75	107	45	7.80							20	5.60		32	
33	267.21	281	20	75	107	45	8.10							20	6.00		33	
34	275.29	289	20	75	107	45	8.50							20	6.40		34	
35	283.36	297	20	75	107	45	8.90		20	80	117	80	17.90		20	6.85		35
36	291.43	306	20	80	117	50	10.10							20	7.20		36	
37	299.51	314	20	80	117	50	10.50	SS400 Welded						20	7.40	SS400 Welded	37	
38	307.58	322	20	80	117	50	10.90							20	8.00		38	
39	315.66	330	20	80	117	50	11.50							20	8.47		39	
40	323.74	338	20	80	117	50	11.80		20	89	127	90	23.70		20	9.00		40
41	331.81	346	20	80	117	50	12.30							20	9.42		41	
42	339.89	354	20	80	117	50	12.70							20	9.75		42	
43	347.97	362	20	80	117	50	13.20							20	10.34		43	
44	356.04	370	20	80	117	50	13.70							20	10.65		44	
45	364.12	378	20	80	117	50	14.20		20	89	127	90		20	11.25		45	
48	388.36	403	20	80	117	50	15.80							20	13.00		48	
50	404.52	419	20	80	117	50	16.80		20	89	127	90		20	14.80		50	
54	436.84	451	20	80	117	50	19.20							20	17.00		54	
60	485.33	500	20	80	117	50	23.10		20	89	127	90	46.20	20	21.00		60	
65	525.73	540	20	80	117	50	28.80							20	25.00		65	
70	566.15	581	20	89	127	63	32.10							20	28.30		70	
75	606.56	621	20	89	127	63	36.20							20	32.00		75	

Note: 1. Determine the required bore size less than the Max. value shown above taking strength reduction into consideration.  
 2. The shaded area of the above table indicates heat treated teeth.  
 3. Those marked \* have slot on hub.

## DID 100 standard roller chain

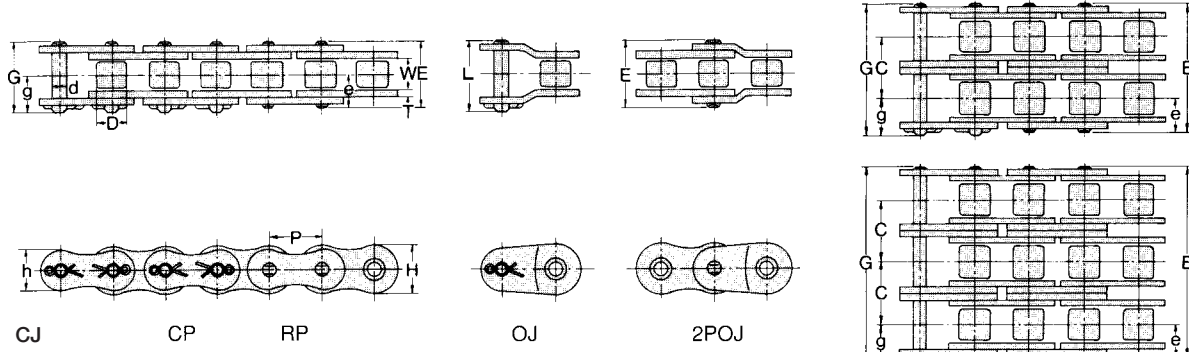

CJ

CP

RP

OJ

2POJ

### Dimensions

Unit (mm)

Chain No.	Pitch	Roller Link Width	Roller dia.	Pin							Transverse Pitch	Plate			JIS		DID		DID		Approx. Weight (kg/m)		
				D	d	E	G	L	e	g		C	T	H	h	Min. Tensile Strength	kgf	Min. Tensile Strength	kgf	Avg. Tensile Strength		kgf	Max. Allowable Load
<b>DID100</b>	100					39.5	42.6	45.2							95.4	9,728	107.0	11,000	118	12,100	22.5	2,300	3.79
<b>DID100-2</b>	100-2					75.4	78.3	81.1							190.8	19,456	215.7	22,000	237	24,200	38.3	3,910	7.53
<b>DID100-3</b>	100-3	31.75	19.05	19.05	9.54	111.2	114.2	115.2	19.8	22.8	35.8	4.0	30.1	26.0	286.2	29,184	323.6	33,000	355	36,300	56.3	5,750	11.3
<b>DID100-4</b>	100-4					147.0	150.0	151.0							381.6	38,912	431.4	44,000	474	48,400	74.4	7,590	15.1
<b>DID100-5</b>	100-5					182.9	185.9	186.9							477.0	48,640	539.3	55,000	593	60,500	87.9	8,970	18.9

Note: The values of average tensile strength and Max. allowable tension are for chains.

### Max. Kilowatt Ratings DID 100

Unit (kW)

No. of Teeth of Small Sprocket	Type of Lubrication	Small Sprocket revolutions per minute (rpm) (See P132 for the details of type of lubrication A, B and C.)																																																
		10	25	50	100	200	300	400	500	600	700	800	900	1000	1100	1200	1300	1400	1600	1800	2000	2200	2400	2500	2600	2700																								
<b>11</b>	<b>A</b>	<b>B</b>										<b>C</b>																																						
		0.90	2.05	3.83	7.14	13.3	19.2	24.9	30.4	35.8	29.9	24.4	20.5	17.5	15.2	13.3	11.8	10.6	8.64	7.24	6.18	5.36	4.70	4.42	4.17	1.09																								
		<b>12</b>	<b>A</b>	<b>B</b>										<b>C</b>																																				
				0.99	2.25	4.20	7.85	14.6	21.1	27.3	33.4	39.4	34.0	27.9	23.3	19.9	17.3	15.2	13.4	12.0	9.85	8.25	7.04	6.11	5.36	5.04	4.75																							
				<b>13</b>	<b>A</b>	<b>B</b>										<b>C</b>																																		
						1.08	2.46	4.58	8.55	16.0	23.0	29.8	36.4	42.9	38.4	31.4	26.3	22.5	19.5	17.1	15.2	13.6	11.1	9.30	7.94	6.89	6.04	5.68	5.36																					
						<b>14</b>	<b>A</b>	<b>B</b>										<b>C</b>																																
								1.17	2.66	4.97	9.27	17.3	24.9	32.3	39.5	46.5	42.9	35.1	29.4	25.1	21.8	19.1	16.9	15.2	12.4	10.4	8.88	7.69	6.75	6.35																				
								<b>15</b>	<b>A</b>	<b>B</b>										<b>C</b>																														
										1.26	2.87	5.35	9.98	18.6	26.8	34.8	42.5	50.1	47.6	38.9	32.6	27.9	24.1	21.2	18.8	16.8	13.8	11.5	9.85	8.53	7.49	7.04																		
										<b>16</b>	<b>A</b>	<b>B</b>										<b>C</b>																												
												1.35	3.07	5.74	10.7	20.0	28.8	37.3	45.6	53.7	52.4	42.9	35.9	30.7	26.6	23.3	20.7	18.5	15.2	12.7	10.9	9.40	8.25	7.76																
												<b>17</b>	<b>A</b>	<b>B</b>										<b>C</b>																										
														1.44	3.28	6.12	11.4	21.3	30.7	39.8	48.7	57.3	57.4	47.0	39.4	33.6	29.1	25.6	22.7	20.3	16.6	13.9	11.9	10.3	9.04															
														<b>18</b>	<b>A</b>	<b>B</b>										<b>C</b>																								
																1.53	3.49	6.51	12.2	22.7	32.7	42.3	51.8	61.0	62.5	51.2	42.9	36.6	31.7	27.9	24.7	22.1	18.1	15.2	12.9	11.2	9.85													
																<b>19</b>	<b>A</b>	<b>B</b>										<b>C</b>																						
																		1.62	3.70	6.91	12.9	24.1	34.6	44.9	54.9	64.6	67.8	55.5	46.5	39.7	34.4	30.2	26.8	24.0	19.6	16.4	14.0	12.2	10.7											
																		<b>20</b>	<b>A</b>	<b>B</b>										<b>C</b>																				
																				1.71	3.91	7.30	13.6	25.4	36.6	47.4	58.0	68.3	73.2	60.0	50.2	42.9	37.2	32.6	28.9	25.9	21.2	17.8	15.2	13.1										
																				<b>21</b>	<b>A</b>	<b>B</b>										<b>C</b>																		
																						1.81	4.12	7.70	14.4	26.8	38.6	50.0	61.1	72.0	78.8	64.5	54.0	46.1	40.0	35.1	31.1	27.9	22.8	19.1	16.3	14.1								
																						<b>22</b>	<b>A</b>	<b>B</b>										<b>C</b>																
																								1.90	4.34	8.09	15.1	28.2	40.6	52.6	64.3	75.7	84.5	69.1	57.9	49.5	42.9	37.6	33.4	29.9	24.4	20.5	17.5	15.2						
																								<b>23</b>	<b>A</b>	<b>B</b>										<b>C</b>														
1.99	4.55																									8.49	15.8	29.6	42.6	55.2	67.4	79.5	90.3	73.9	61.9	52.9	45.8	40.2	35.7	31.9	26.1	21.9	18.7	16.2						
<b>24</b>	<b>A</b>																									<b>B</b>										<b>C</b>														
		2.09	4.76																							8.89	16.6	31.0	44.6	57.8	70.6	83.2	95.6	78.8	66.0	56.4	48.9	42.9	38.0	34.0	27.9	23.3	19.9	17.3						
		<b>25</b>	<b>A</b>																							<b>B</b>										<b>C</b>														
				2.18	4.98																					9.29	17.3	32.4	46.6	60.4	73.8	87.0	100	83.7	70.2	59.9	51.9	45.6	40.4	36.2	29.6	24.8	21.2	18.3						
				<b>28</b>	<b>A</b>																					<b>B</b>										<b>C</b>														
						2.47	5.63																			10.5	19.6	36.6	52.7	68.2	83.4	98.3	113	99.3	83.2	71.0	61.6	54.0	47.9	42.9	35.1	29.4	25.1							
						<b>30</b>	<b>A</b>																			<b>B</b>										<b>C</b>														
								2.66	6.06																	11.3	21.1	39.4	56.7	73.5	89.9	106	122	110	92.3	78.8	68.3	59.9	53.1	47.6	38.9	32.6								
								<b>32</b>	<b>A</b>																	<b>B</b>										<b>C</b>														
										2.85	6.50															12.1	22.6	42.2	60.8	78.8	96.3	114	130	121	102	86.8	75.2	66.0	58.5	52.4	42.9	35.9								
										<b>35</b>	<b>A</b>															<b>B</b>										<b>C</b>														
												3.14	7.16													13.4	24.9	46.5	67.0	86.8	106	125	144	139	116	99.3	86.0	75.5	67.0	59.9	49.4									
												<b>40</b>	<b>A</b>													<b>B</b>										<b>C</b>														
														3.63	8.27											15.4	28.8	53.7	77.4	100	123	144	166	169	142	121	105	92.3	81.8	73.2										
														<b>45</b>	<b>A</b>											<b>B</b>										<b>C</b>														
																4.12	9.39									17.5	32.7	61.0	87.9	114	139	164	188	202	169	145	125	110	97.6											

Note: 1. Values in the table above are for simplex chain only. For multiplex chains, please multiply the coefficient of multi-strand. (See "Chain Selection" on P120).

2. Please consult with us when the ratings beyond the dotted line to rightward.

# DID 100 Standard Sprocket

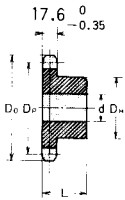

Single sprocket with hub on one side (Single B type)

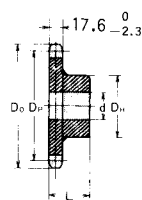

Single sprocket with hub on one side (Single BW type Welded)

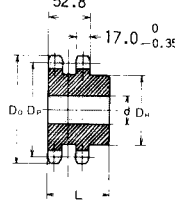

Double sprocket with hub on one side (Double B type)

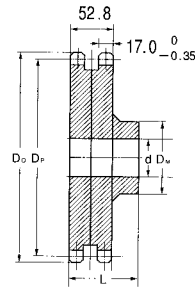

Double sprocket with hub on one side (Double BW type Welded)

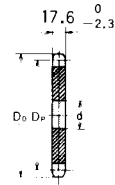

Flat plain (A type)

Unit (mm)

Number of teeth	Pitch dia. D <sub>P</sub>	Tip dia. D <sub>o</sub>	Single sprocket with hub on one side (B type/ BW type)						Double sprocket with hub on one side (B type/ BW type)						Flat plain (A type)			Number of teeth
			Bore d		Hub		Approx. weight (Kg)	Material	Bore d		Hub		Approx. weight (Kg)	Material	Stock d	Approx. weight (Kg)	Material	
			Stock	Max.	(Dia.) D <sub>H</sub>	(Length) L			Stock	Max.	(Dia.) D <sub>H</sub>	(Length) L						
10	102.74	116	20	43	65	50	1.86							20	1.68		10	
11	112.70	127	20	50	75	50	2.30							20	3.00		11	
12	122.67	137	20	57	86	50	2.90							20	3.86		12	
13	132.67	147	20	59	88	50	3.10							20	3.40		13	
14	142.68	157	20	59	88	50	3.60							20	5.60		14	
15	152.71	167	20	70	98	50	4.20							20	6.00		15	
16	162.74	178	20	66	98	50	4.60							20	6.50		16	
17	172.79	188	20	75	107	50	5.30							20	7.60		17	
18	182.84	198	20	75	107	50	5.70							20	7.90		18	
19	192.90	209	20	75	107	50	6.10							20	8.30		19	
20	202.96	219	20	75	107	50	6.50							20	8.60		20	
21	213.03	229	20	75	107	50	7.00							20	8.90		21	
22	223.10	240	20	80	117	56	7.90							20	8.56		22	
23	233.17	250	20	80	117	56	8.40							20	9.12		23	
24	243.25	260	20	80	117	56	8.80		20	95	137	90	17.80	20	9.60		24	
25	253.32	270	20	80	117	56	9.30							20	10.10		25	
26	263.40	281	20	80	117	56	9.80							20	10.70		26	
27	273.49	291	20	80	117	56	10.40							20	11.50		27	
28	283.57	301	20	80	117	56	10.90							20	11.90		28	
29	293.66	311	20	80	117	56	11.60							20	12.60		29	
30	303.75	321	20	80	117	56	12.10		20	95	137	90	24.30	20	13.20		30	
31	313.83	331	20	80	117	56	12.80									SS400	31	
32	323.92	341	20	80	117	56	13.40							20	15.98		32	
33	334.01	352	20	80	117	56	14.10										33	
34	344.11	362	20	80	127	63	14.80							20	16.90		34	
35	354.20	372	20	89	127	63	16.60		20	95	137	90	30.90	20	17.88		35	
36	364.29	382	20	89	127	63	17.20							20	16.90		36	
37	374.38	392	20	89	127	63	17.90							20	18.80		37	
38	384.47	402	20	89	127	63	19.40							20	20.08		38	
39	394.57	412	20	89	127	63	19.90										39	
40	404.67	422	20	90	127	63	20.40		20	103	147	90	40.70	20	21.98		40	
41	414.77	433	20	90	127	63	21.50							20	22.50		41	
42	424.86	443	20	90	127	63	22.70							20	23.68		42	
43	434.96	453	20	90	127	63	23.50										43	
44	445.06	463	20	90	127	63	24.10										44	
45	455.16	473	20	90	127	63	24.70		20	103	147	100	49.30	20	26.48		45	
48	485.45	503	20	90	127	63	27.50							20	29.48		48	
50	505.65	524	20	90	127	63	28.50							20	31.68		50	
54	546.05	564	20	103	147	80	37.40							20	36.48		54	
60	606.66	625	20	103	147	80	44.30		20	103	147	125	89.00	20	44.28		60	
65	657.17	675	20	103	147	80	54.88							20	50.48		65	
70	707.68	726	20	103	147	100	64.96							20	58.48		70	
75	758.20	777	20	103	147	100	72.98										75	

Note: 1. Determine the required bore size less than the Max. value shown above taking strength reduction into consideration.  
2. The shaded area of the above table indicates heat treated teeth.



## DID 120 standard roller chain

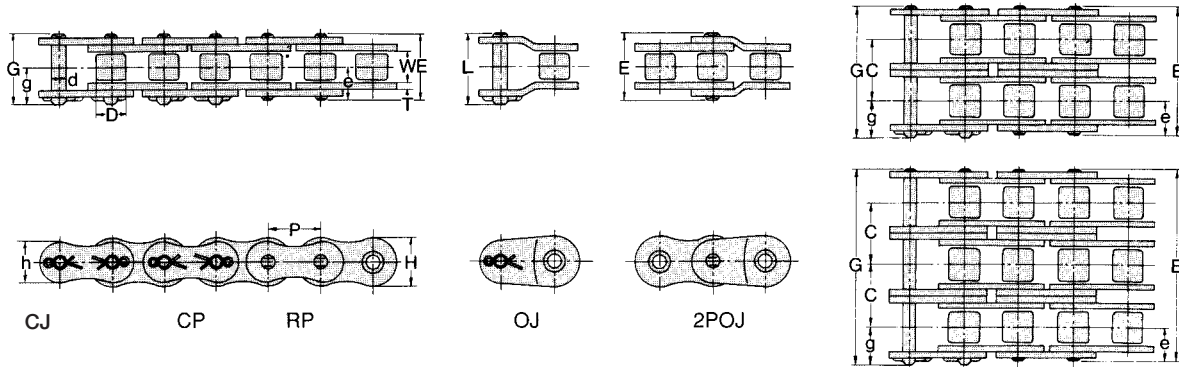

### Dimensions

Unit (mm)

Chain No.	Pitch	Roller Link Width	Roller dia.	Pin						Transverse Pitch	Plate			JIS		DID		DID		Approx. Weight (kg/m)			
				d	E	G	L	e	g		C	T	H	h	Min. Tensile Strength	Min. Tensile Strength	Avg. Tensile Strength	Max. Allowable Load					
DID	JIS	P	W	D											kN	kgf	kN	kgf	kN	kgf			
<b>DID120</b>	120					49.8	53.8	56.1							137.1	13,980	147.1	15,000	166	17,000	30.4	3,100	5.49
<b>DID120-2</b>	120-2					75.4	99.2	99.6							274.2	27,960	294.2	30,000	333	34,000	51.6	5,270	11.0
<b>DID120-3</b>	120-3	38.10	25.40	22.23	11.11	140.6	143.9	145.0	24.9	28.9	45.4	4.80	36.2	31.2	411.3	41,940	441.3	45,000	500	51,000	76.0	7,750	16.5
<b>DID120-4</b>	120-4					186.1	189.4	190.5							548.4	55,920	588.4	60,000	666	68,000	100	10,230	22.0
<b>DID120-5</b>	120-5					231.5	234.8	235.9							685.5	69,900	735.5	75,000	833	85,000	118	12,090	27.5

Note: The values of average tensile strength and Max. allowable tension are for chains.

### Max. Kilowatt Ratings DID 120

Unit (kW)

No. of Teeth of Small Sprocket	Small Sprocket revolutions per minute (rpm) (See P132 for the details of type of lubrication A, B and C.)																												
	Type of Lubrication			10	25	50	100	150	200	300	400	500	600	700	800	900	1000	1100	1200	1300	1400	1500	1600	1700	1800	1900	2000	2100	
	A			B											C														
<b>11</b>	1.51	3.45	6.45	12.0	17.3	22.5	32.3	41.9	51.2	43.5	34.6	28.3	23.7	20.2	17.5	15.4	13.7	12.2	11.0	10.0	9.13	8.38	7.73	7.15	6.65				
<b>12</b>	1.66	3.79	7.08	13.2	19.0	24.7	35.5	46.0	56.3	49.6	39.4	32.2	27.0	23.1	20.0	17.5	15.6	13.9	12.6	11.4	10.4	9.55	8.80	8.15					
<b>13</b>	1.81	4.14	7.72	14.4	20.8	26.9	38.7	50.2	61.3	55.9	44.4	36.3	30.5	26.0	22.5	19.8	17.5	15.7	14.2	12.8	11.7	10.8	9.93	9.19					
<b>14</b>	1.96	4.48	8.36	15.6	22.5	29.1	42.0	54.4	66.4	62.5	49.6	40.6	34.0	29.1	25.2	22.1	19.6	17.5	15.8	14.4	13.1	12.0	11.1	10.3					
<b>15</b>	2.12	4.83	9.01	16.8	24.2	31.4	45.2	58.6	71.6	69.3	55.0	45.0	37.7	32.2	27.9	24.5	21.7	19.5	17.5	15.9	14.5	13.3	12.3						
<b>16</b>	2.27	5.18	9.66	18.0	26.0	33.6	48.5	62.8	76.7	76.4	60.6	49.6	41.6	35.5	30.8	27.0	24.0	21.4	19.3	17.5	16.0	14.7	13.6						
<b>17</b>	2.42	5.53	10.3	19.3	27.7	35.9	51.7	67.0	81.9	83.6	66.4	54.3	45.5	38.9	33.7	29.6	26.2	23.5	21.2	19.2	17.5	16.1	14.8						
<b>18</b>	2.58	5.88	11.0	20.5	29.5	38.2	55.0	71.3	87.2	91.1	72.3	59.2	49.6	42.4	36.7	32.2	28.6	25.6	23.1	20.9	19.1	17.5	16.2						
<b>19</b>	2.73	6.23	11.6	21.7	31.3	40.5	58.3	75.6	92.4	98.8	78.4	64.2	53.8	45.9	39.8	34.9	31.0	27.7	25.0	22.7	20.7	19.0							
<b>20</b>	2.89	6.59	12.3	22.9	33.0	42.8	61.7	79.9	97.7	107	84.7	69.3	58.1	49.6	43.0	37.7	33.5	30.0	27.0	24.5	22.4	20.5							
<b>21</b>	3.04	6.94	13.0	24.2	34.8	45.1	65.0	84.2	103	115	91.1	74.6	62.5	53.4	46.3	40.6	36.0	32.2	29.1	26.4	24.1	22.1							
<b>22</b>	3.20	7.30	13.6	25.4	36.6	47.5	68.4	88.6	108	123	97.7	80.0	67.0	57.2	49.6	43.5	38.6	34.6	31.2	28.3	25.8	23.7							
<b>23</b>	3.36	7.66	14.3	26.7	38.4	49.8	71.7	92.9	114	132	104	85.5	71.7	61.2	53.0	46.5	41.3	36.9	33.3	30.2	27.6								
<b>24</b>	3.52	8.02	15.0	27.9	40.2	52.1	75.1	97.3	119	140	111	91.1	76.4	65.2	56.5	49.6	44.0	39.4	35.5	32.2	29.4								
<b>25</b>	3.68	8.38	15.6	29.2	42.1	54.5	78.5	102	124	146	118	96.9	81.2	69.3	60.1	52.7	46.8	41.9	37.7	34.3	31.3								
<b>28</b>	4.15	9.47	17.7	33.0	47.5	61.6	88.7	115	140	165	140	115	96.2	82.2	71.2	62.5	55.4	49.6	44.7	40.6									
<b>30</b>	4.47	10.2	19.1	35.6	51.2	66.3	95.5	124	151	178	156	127	107	91.1	79.0	69.3	61.5	55.0	49.6										
<b>32</b>	4.80	10.9	20.4	38.1	54.9	71.1	102	133	162	191	171	140	118	100	87.0	76.4	67.7	60.6											
<b>35</b>	5.29	12.1	22.5	42.0	60.5	78.4	113	146	179	211	196	160	135	115	99.5	87.4	77.5												
<b>40</b>	6.11	13.9	26.0	48.5	69.9	90.5	130	169	206	243	240	196	164	140	122														
<b>45</b>	6.93	15.8	29.5	55.1	79.3	103	148	192	234	276	286	234	196	167															

Note: 1. Values in the table above are for simplex chains only. For multiplex chains, please multiply the coefficient of multi-strand. (See "Chain Selection" on P120).  
 2. Consult us when the ratings beyond the dotted line to rightward.



# DID 120 Standard Sprocket

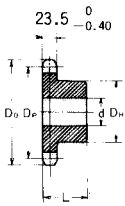

Single sprocket with hub on one side (Single B type)

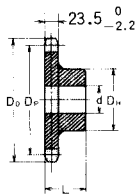

Single sprocket with hub on one side (Single BW type Welded)

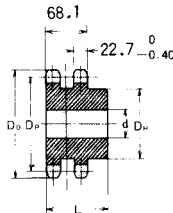

Double sprocket with hub on one side (Double B type)

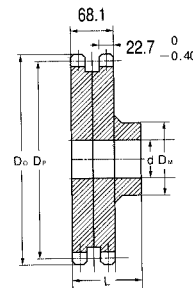

Double sprocket with hub on one side (Double BW type Welded)

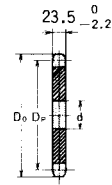

Flat plain (A type)

Unit (mm)

Number of teeth	Pitch dia. DP	Tip dia. Do	Single sprocket with hub on one side (B type/ BW type)						Double sprocket with hub on one side (B type/ BW type)						Flat plain (A type)			Number of teeth
			Bore d		Hub		Approx. weight (Kg)	Material	Bore d		Hub		Approx. weight (Kg)	Material	Stock d	Approx. weight (Kg)	Material	
			Stock	Max.	(Dia.) Dh	(Length) L			Stock	Max.	(Dia.) Dh	(Length) L						
10	123.29	140	25	50	78	56	3.20		26	50	80	100		25	1.80		10	
11	135.24	152	25	60	91	56	4.00		26	60	90	100		25	2.27		11	
12	147.21	165	25	65	98	56	4.80		28	71	103	100	9.20	25	2.60		12	
13	159.20	177	25	70	98	56	5.30		28	80	115	100	11.10	25	3.20		13	
14	171.22	190	25	70	107	56	6.30		28	75	120	100	11.40	25	3.67		14	
15	183.25	202	25	80	117	63	7.80		33	80	120	100	13.20	25	4.22		15	
16	195.29	214	25	80	117	63	8.40	S35C	33	80	140	100	14.40	25	5.00		16	
17	207.35	227	25	80	117	63	9.10		33	80	140	100	15.70	25	5.60		17	
18	219.41	239	25	80	117	63	9.90		33	89	150	100	18.00	25	6.25		18	
19	231.48	251	25	80	117	63	10.70		33	89	150	100	19.40	25	7.00		19	
20	243.55	263	25	89	127	63	12.10		33	89	150	100	21.00	25	7.86		20	
21	255.63	276	25	89	127	63	13.00		33	89	150	100	22.60	25	8.90		21	
22	267.72	288	30	89	127	63	13.40							30	9.80		22	
23	279.80	300	30	89	127	63	14.30							30	10.50		23	
24	291.90	312	30	89	127	63	15.20		30	110	157	100	31.00	30	11.50		24	
25	303.99	324	30	89	127	63	16.20							30	12.56		25	
26	316.09	337	30	89	127	63	17.20							30	14.00		26	
27	328.19	349	30	89	127	63	18.30							15.50		SS400	27	
28	340.29	361	30	95	137	71	21.84							30	16.50		28	
30	364.50	385	30	95	137	71	23.20		30	110	157	100	43.90	30	19.00		30	
32	388.71	410	30	95	137	71	25.70							30	21.50		32	
35	425.04	446	30	95	137	71	29.70		30	110	157	100	56.80	30	26.00		35	
36	437.15	458	30	95	137	71	30.70							30	27.50		36	
38	461.38	483	30	95	137	71	34.70	SS400 Welded						30	31.00		38	
40	485.60	507	30	103	147	80	38.20		30	125	177	140	81.30	30	34.00		40	
42	509.84	531	30	103	147	80	42.00							30	38.00		42	
45	546.19	568	30	103	147	80	47.60		30	125	177	140	98.50	30	43.00		45	
48	582.54	604	30	103	147	80	53.00							30	49.00		48	
50	606.78	628	30	103	147	100	62.87										50	
54	655.26	677	30	103	147	100	71.72							30	60.00		54	
60	727.99	750	30	118	167	100	75.00		30	125	177	160	131.60	30	71.50		60	
65	788.60	811	30	118	167	100	81.00										65	
70	849.22	871	30	118	167	112	82.30										70	
75	909.84	932	30	118	167	112	90.40										75	

Note: 1. Determine the required bore size less than the Max. value shown above taking strength reduction into consideration.  
 2. The shaded area of the above table indicates heat treated teeth.

## DID 140 standard roller chain

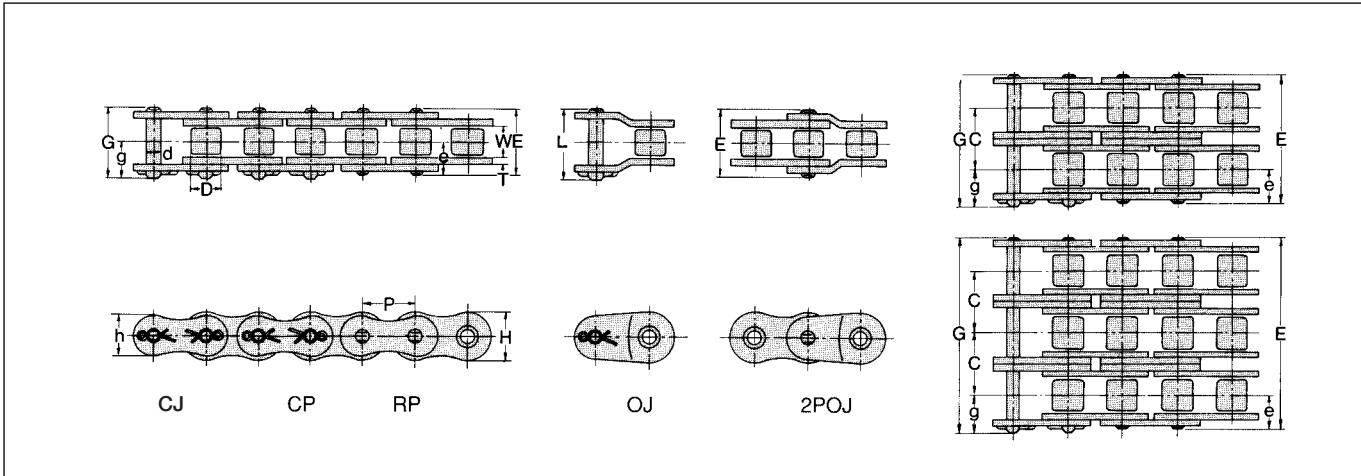

### Dimensions

Unit (mm)

Chain No.	Pitch	Roller Link Width	Roller dia.	Pin						Transverse Pitch	Plate			JIS		DID		DID		Approx. Weight (kg/m)			
				d	E	G	L	e	g		C	T	H	h	Min. Tensile Strength	Min. Tensile Strength	Avg. Tensile Strength	Max. Allowable Load					
DID	JIS	P	W	D																			
<b>DID140</b>	140					53.6	58.4	59.6							185.9	18,956	193.1	19,700	215	22,000	40.2	4,100	7.11
<b>DID140-2</b>	140-2					102.6	107.4	108.6							371.8	37,912	386.3	39,400	431	44,000	68.3	6,970	14.1
<b>DID140-3</b>	140-3	44.45	25.40	25.40	12.71	151.5	156.3	157.5	26.8	31.7	48.9	5.60	41.9	36.3	557.7	56,868	579.5	59,100	647	66,000	100	10,250	21.1
<b>DID140-4</b>	140-4					200.5	205.3	206.5							743.6	75,824	772.7	78,800	862	88,000	132	13,530	28.1
<b>DID140-5</b>	140-5					249.4	254.2	255.4							929.5	94,780	965.9	98,500	1,070	110,000	156	15,990	34.9

Note: The values of average tensile strength and Max. allowable tension are for chains.

### Max. Kilowatt Ratings DID 140

Unit (kW)

No. of Teeth of Small Sprocket	Small Sprocket revolutions per minute (rpm) (See P132 for the details of type of lubrication A, B and C.)																											
	Type of Lubrication			10	25	50	100	150	200	250	300	350	400	450	500	550	600	700	800	900	1000	1100	1200	1300	1400	1500	1600	1650
	A			B											C													
11	2.34	5.34	9.97	18.6	26.8	34.7	42.5	50.0	57.5	64.8	72.1	64.7	56.1	49.3	39.1	32.0	26.8	22.9	19.8	17.4	15.4	13.8	12.5	11.3	10.8			
12	2.57	5.87	11.0	20.4	29.5	38.2	46.6	55.0	63.1	71.2	79.2	73.8	63.9	56.1	44.5	36.5	30.6	26.1	22.6	19.8	17.6	15.7	14.2	12.9	12.3			
13	2.81	6.40	12.0	22.3	32.1	41.6	50.9	59.9	68.8	77.6	86.3	83.2	72.1	63.3	50.2	41.1	34.4	29.4	25.5	22.4	19.8	17.8	16.0	14.5				
14	3.04	6.93	12.9	24.2	34.8	45.1	55.1	64.9	74.6	84.1	93.5	93.0	80.6	70.7	56.1	45.9	38.5	32.9	28.5	25.0	22.2	19.8	17.9	16.2				
15	3.28	7.47	13.9	26.0	37.5	48.6	59.3	69.9	80.3	90.6	101	103	89.4	78.4	62.2	50.9	42.7	36.5	31.6	27.7	24.6	22.0	19.8	5.76				
16	3.51	8.01	15.0	27.9	40.2	52.1	63.6	75.0	86.1	97.1	108	114	98.4	86.4	68.6	56.1	47.0	40.2	34.8	30.6	27.1	24.2	21.9					
17	3.75	8.55	16.0	29.8	42.9	55.6	67.9	80.1	92.0	104	115	124	108	94.6	75.1	61.5	51.5	44.0	38.1	33.5	29.7	26.6	23.9					
18	3.99	9.10	17.0	31.7	45.6	59.1	72.3	85.2	97.8	110	123	135	117	103	81.8	67.0	56.1	47.9	41.5	36.5	32.3	28.9	26.1					
19	4.23	9.64	18.0	33.6	48.4	62.7	76.6	90.3	104	117	130	143	127	112	88.7	72.6	60.9	52.0	45.0	40.0	35.1	31.4	28.3					
20	4.47	10.2	19.0	35.5	51.1	66.2	81.0	95.4	110	124	137	151	138	121	95.8	78.4	65.7	56.0	48.6	43.0	37.9	33.9	5.69					
21	4.71	10.7	20.1	37.4	53.9	69.8	85.4	101	116	130	145	159	148	130	103	84.4	70.7	60.4	52.3	45.9	40.7	36.5						
22	4.95	11.3	21.1	39.3	56.7	73.4	89.8	106	121	137	152	167	159	139	111	90.5	75.8	64.7	56.1	49.3	43.7	39.1						
23	5.20	11.9	22.1	41.3	59.5	77.0	94.2	111	127	144	160	176	170	149	118	96.7	81.1	69.2	60.0	52.7	46.7	41.8						
24	5.44	12.4	23.2	43.2	62.3	80.7	98.6	116	133	151	167	184	181	159	126	103	86.4	73.8	63.9	56.1	49.8	44.2						
25	5.69	13.0	24.2	45.2	65.1	84.3	103	121	139	157	175	192	192	169	134	110	91.9	78.4	68.0	59.7	52.9	47.5						
28	6.43	14.7	27.4	51.1	73.5	95.3	116	137	158	178	198	217	228	200	159	130	109	93.0	80.6	70.7								
30	6.92	15.8	29.5	55.0	79.2	103	125	148	170	192	213	234	253	222	176	144	121	103	89.4									
32	7.42	16.9	31.6	59.0	85.0	110	135	159	182	205	228	251	273	244	194	159	133	114	98.0									
35	8.18	18.7	34.8	65.0	93.6	121	148	175	201	226	252	277	301	280	222	182	152	130										
40	9.45	21.6	40.2	75.0	108	140	171	202	232	261	291	319	348	342	271	222												
45	10.73	24.5	45.7	85.2	123	159	194	229	263	297	330	363	395	408	323													

Note: 1. Values in the table above are for simplex chains only. For multiplex chains, please multiply the coefficient of multi-strand. (See "Chain Selection" on P120).  
2. Consult us when the ratings beyond the dotted line to rightward.

# DID 140 Standard Sprocket

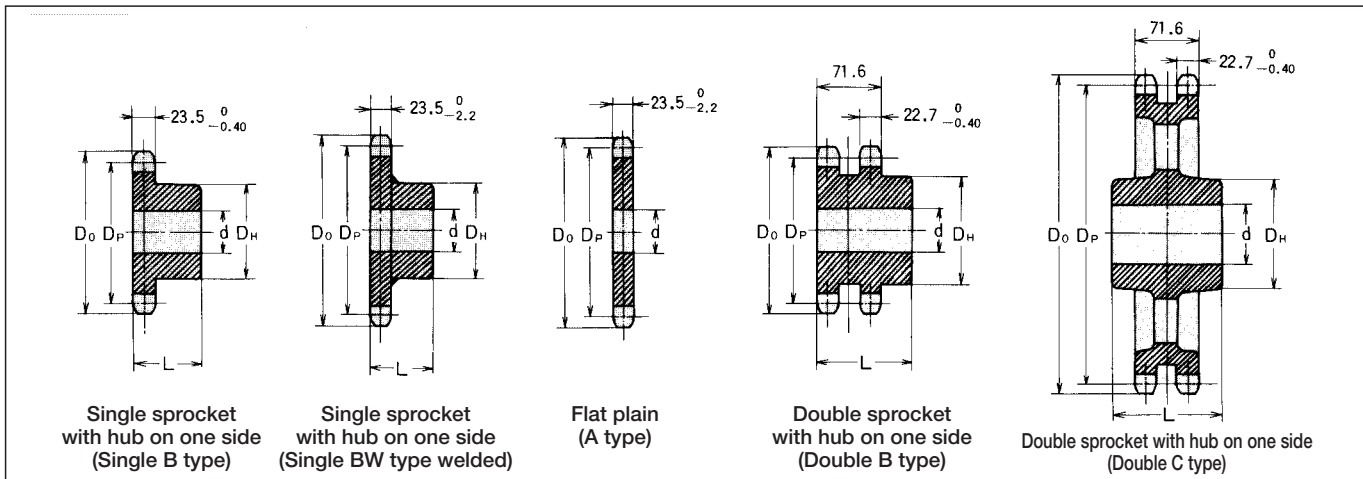

Unit (mm)

Number of teeth	Pitch dia. DP	Tip dia. DO	Single sprocket with hub on one side (B type/ BW type)						Flat plain (A type)			Number of teeth
			Bore d		Hub		Approx. weight (Kg)	Material	Stock d	Approx. weight (Kg)	Material	
			Stock	Max.	(Dia.) DH	(Length) L						
10	143.84	163	25	60	91	56	4.40		25	2.90		10
11	157.78	178	25	73	106	56	5.50		25	3.40		11
12	171.74	193	25	80	117	56	6.60	S35C	25	4.00		12
13	185.74	207	25	80	117	63	7.90		25	4.70		13
14	199.76	221	25	89	127	63	9.30		25	5.50		14
15	213.79	236	25	89	127	63	10.10		25	6.30		15
16	227.84	250	25	89	127	63	11.19		25	7.20		16
17	241.91	264	25	89	127	63	12.14	S35C	25	8.10		17
18	255.98	279	25	89	127	63	13.00		25	9.10		18
19	270.06	293	25	95	137	71	15.60	SS400 Welded	25	10.30		19
20	284.15	307	25	95	137	71	16.70		25	11.40		20
21	298.24	322	30	95	137	71	17.90		25	12.60		21
22	312.34	336	30	95	137	71	18.40		30	13.80		22
23	326.44	350	30	95	137	71	18.90		30	15.10	SS400	23
24	340.54	364	30	95	137	71	20.90		30	16.40		24
25	354.65	379	30	103	147	80	24.10		30	17.80		25
26	368.77	393	30	103	147	80	25.50		30	19.20		26
30	425.24	450	30	103	147	80	31.50		30	25.50		30
32	453.49	478	30	110	157	90	34.00	SS400	30	29.00		32
35	495.88	521	30	110	157	90	40.10	Welded	30	34.60		35
38	538.27	563	30	110	157	90	51.00		30	41.00		38
40	566.54	591	30	110	157	90	53.10		30	45.40		40
42	594.81	620	30	110	157	90	60.00		30	50.00		42
45	637.22	662	30	118	167	100	67.60		30	57.30		45
48	679.63	705	30	118	167	100	74.30		30	65.20		48
60	849.32	875	38	118	167	112	111.20		30	120.00		60

- Note: 1. Determine the required bore size less than the Max. value shown above taking strength reduction into consideration.  
 2. DID's finishing process is the basic application to the bore surface finishing for doubled sprockets of B type and C type.  
 3. For double C type sprockets, three or four types of bore size are available in 26 and larger number of teeth than that. The bigger standard bore is applied in case the required bore size ranges between the two types of bore size.  
 4. Heat treatment on teeth portion is available when requested.

Unit (mm)

Type	Number of teeth	Pitch dia. DP	Tip dia. DO	Bore d		Hub		Approx. weight (Kg)	Material
				Min.	Max.	(Dia.) DH	(Length) L		
				B	13	185.74	207	40	80
14	199.76	221	40		80	140	100	17.0	
15	213.79	236	45		90	155	110	19.9	
16	227.84	250	45		95	170	120	23.3	
17	241.91	264	50		105	185	130	26.6	
18	255.98	279	50		115	200	150	30.6	
19	270.06	293	60		125	215	150	34.1	
20	284.15	307	60		130	225	160	37.8	
21	298.24	322	65		140	240	170	42.1	
22	312.34	336	65		150	250	170	72.0	
24	340.54	364	65		160	260	170	82.7	
C	26	368.77	393					74.5	Carbon steel or cast steel
	30	425.24	450					76.5	
	32	453.49	478	65	85	140	100	80.9	
	35	495.88	521	85	110	180	130	87.5	
	38	538.27	563	110	140	225	170	93.8	
	40	566.54	591					98.9	
	45	637.22	662					112.0	
	50	707.91	733					141.0	
	55	778.61	804					158.0	
	60	849.32	875	65	85	140	100	176.0	
	65	920.03	946	85	110	180	130	196.0	
	70	990.75	1,016	110	145	225	170	217.0	
	75	1,061.47	1,087	145	175	270	200	239.0	
	80	1,132.20	1,158					261.0	
	90	1,273.66	1,300					314.0	

## DID 160 standard roller chain

Roller Chains for Power Transmission  
Standard Roller Chain

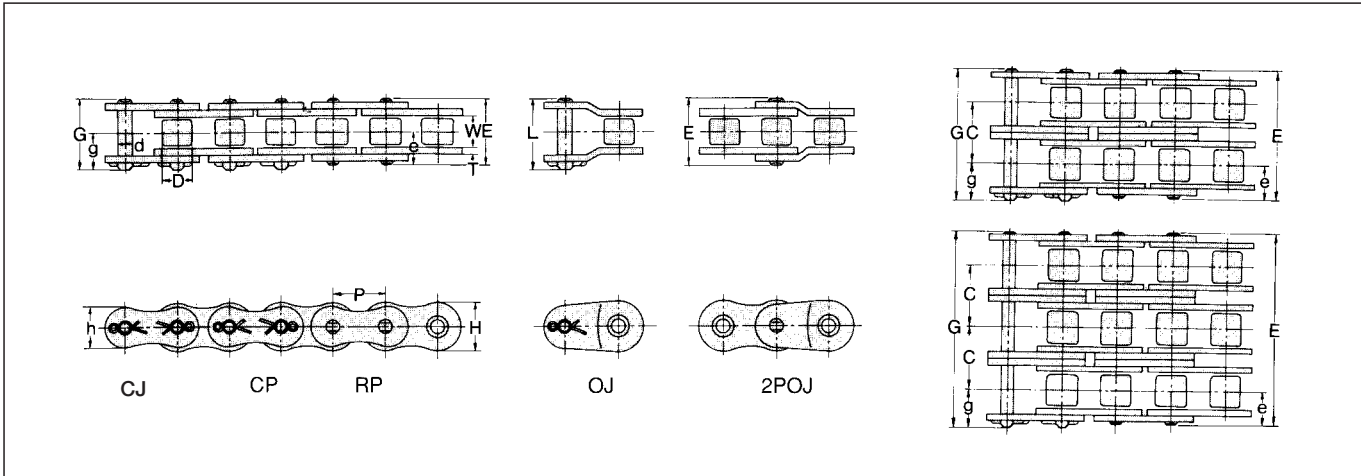

### Dimensions

Unit (mm)

Chain No.	Pitch	Roller Link Width	Roller dia.	Pin						Transvers e Pitch	Plate			JIS		DID		DID		Approx. Weight (kg/m)			
				d	E	G	L	e	g		C	T	H	h	Min. Tensile Strength	Min. Tensile Strength	Avg. Tensile Strength	Max. Allowable Load					
DID	JIS	P	W	D	d	E	G	L	e	g	C	T	H	h	kN	kgf	kN	kgf	kN	kgf			
<b>DID160</b>	160					63.6	68.2	69.7							244.6	24,942	245.1	25,000	269	27,500	52.9	5,400	9.82
<b>DID160-2</b>	160-2					122.2	126.8	128.3							489.2	49,884	490.3	50,000	539	55,000	90.9	9,180	19.4
<b>DID160-3</b>	160-3	50.80	31.75	28.58	14.29	180.8	185.4	186.9	31.9	36.5	58.5	6.40	47.8	41.4	733.8	74,826	735.5	75,000	809	82,500	132	13,500	29.0
<b>DID160-4</b>	160-4					239.3	243.8	245.4							978.4	99,768	980.6	100,000	1,070	110,000	178	17,820	38.6
<b>DID160-5</b>	160-5					297.8	303.4	303.9							1,223.0	124,710	1,225	125,000	1,340	137,500	206	21,060	48.2

Note: The values of average tensile strength and Max. allowable tension are for chains.

### Max. Kilowatt Ratings DID 160

Unit (kW)

No. of Teeth of Small Sprocket	Small Sprocket revolutions per minute (rpm) (See P132 for the details of type of lubrication A, B and C.)																																																																																																																																																																																																																																																																																																																																																																																																																																																																		
	10		25		50		100		150		200		250		300		350		400		450		500		550		600		650		700		750		800		850		900		1000		1100		1200		1300		1400																																																																																																																																																																																																																																																																																																																																																																																																																		
Type of Lubrication	A														B														C																																																																																																																																																																																																																																																																																																																																																																																																																																						
<b>11</b>	3.40	7.75	14.5	27.0	38.9	50.4	61.6	72.6	83.4	94.0	84.4	72.0	62.4	54.8	48.6	43.5	39.2	35.6	32.5	29.8	25.5	22.1	19.4	17.2	3.73	8.52	15.9	29.7	42.7	55.4	67.7	79.7	91.6	103	96.1	82.1	71.2	62.4	55.4	49.6	44.7	40.6	37.0	34.0	29.0	25.2	22.1	19.6	4.07	9.29	17.3	32.3	46.6	60.4	73.8	86.9	99.9	113	108	92.6	80.2	70.4	62.4	55.9	50.4	45.7	41.8	38.3	32.7	28.4	24.9	22.1	4.41	10.1	18.8	35.0	50.5	65.4	79.9	94.2	108	122	121	103	89.7	78.7	69.8	62.4	56.3	51.1	46.7	42.8	36.6	31.7	27.8	24.7	4.75	11.6	20.2	37.7	54.4	70.4	86.1	101	117	131	134	115	99.4	87.3	77.4	69.3	62.4	56.7	51.8	47.5	40.6	35.2	30.9	14.7	5.09	11.6	21.7	40.5	58.3	75.5	92.3	109	125	141	148	126	110	96.1	85.3	76.3	68.8	62.4	57.0	52.3	44.7	38.7	34.0	5.44	12.4	23.2	43.2	62.2	80.6	98.6	116	133	150	162	138	120	105	93.4	83.6	75.3	68.4	62.4	57.3	48.9	42.4	37.2	5.79	13.2	24.6	46.0	66.2	85.8	105	124	142	160	177	151	131	115	102	91.0	82.1	74.5	68.0	62.4	53.3	46.2	40.6	6.13	14.0	26.1	48.7	70.2	90.9	111	131	150	170	189	164	142	124	110	98.7	89.0	80.8	73.8	67.7	57.8	50.1	44.0	6.48	14.8	27.6	51.5	74.2	96.1	117	138	159	179	199	177	153	134	119	107	96.1	87.3	79.7	73.1	62.4	54.1	47.5	6.83	15.6	29.1	54.3	78.2	101	124	146	168	189	210	190	165	145	128	115	103	93.9	85.7	78.7	67.2	58.2	25.9	7.19	16.4	30.6	57.1	82.2	107	130	153	176	199	221	204	177	155	137	123	111	101	91.9	84.4	72.0	62.4	7.54	17.2	32.1	59.9	86.3	112	137	161	185	209	232	218	189	166	147	131	119	108	98.3	90.2	77.0	66.8	7.89	18.0	33.6	62.7	90.3	117	143	169	194	218	243	232	201	177	157	140	126	115	105	96.1	82.1	71.2	8.25	18.8	35.1	65.5	94.4	122	149	176	202	228	254	247	214	188	167	149	134	122	111	102	87.3	75.6	9.32	21.3	39.7	74.1	107	138	169	199	229	258	287	293	254	223	197	177	159	145	132	121	10.1	22.9	42.8	79.8	115	149	182	215	246	278	309	324	281	247	219	196	177	160	146	134	10.8	24.6	45.9	85.6	123	160	195	230	264	298	331	357	310	272	241	216	195	177	161	11.9	27.1	50.5	94.2	136	176	215	253	291	328	365	401	354	311	276	247	223	13.7	31.3	58.3	109	157	203	248	293	336	379	421	463	433	380	337	15.6	35.5	66.3	124	178	231	282	332	382	431	479	526	517	453

Note: 1. Values in the table above are for simplex chains only. For multiplex chains, please multiply the coefficient of multi-strand. (See "Chain Selection" on P120).  
2. Consult us when the ratings beyond the dotted line to rightward.

# DID 160 Standard Sprocket

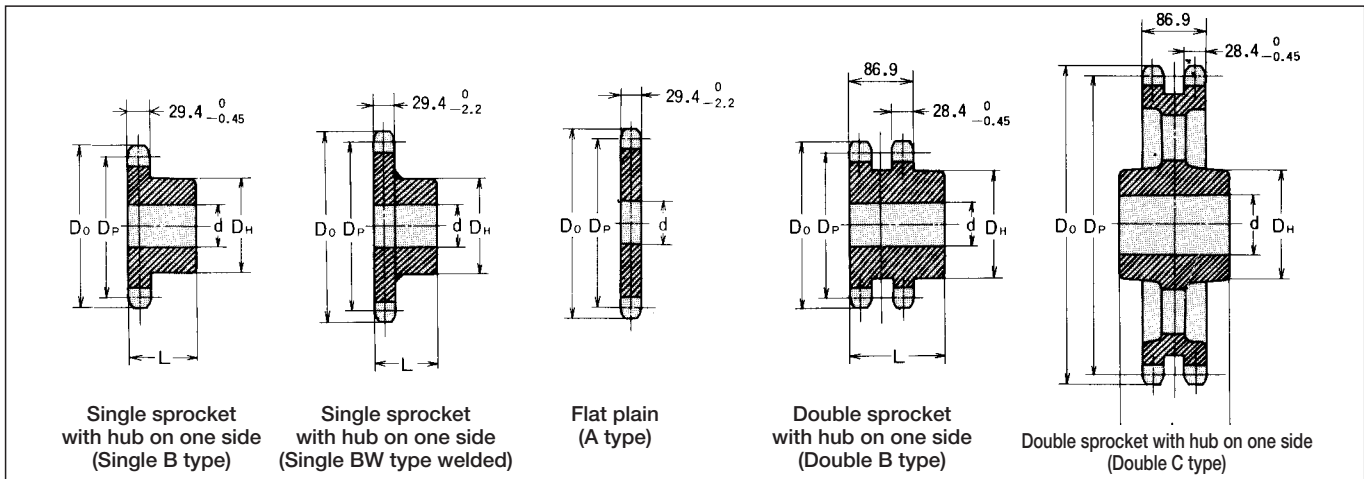

Unit (mm)

Number of teeth	Pitch dia. DP	Tip dia. Do	Single sprocket with hub on one side (B type/ BW type)						Flat plain (A type)			Number of teeth
			Bore d		Hub		Approx. weight (Kg)	Material	Stock d	Approx. weight (Kg)	Material	
			Stock	Max.	(Dia.) DH	(Length) L						
10	164.39	186	25	70	105	63	6.80		25	4.80		10
11	180.31	204	25	80	117	63	8.30	S35C	25	5.79		11
12	196.28	220	25	89	127	63	9.90		25	6.86		12
13	212.27	237	25	95	137	71	12.50		25	8.03		13
14	228.30	253	25	95	137	71	13.80		25	9.28		14
15	244.33	269	30	95	137	71	15.20	S35C	30	10.63		15
16	260.39	286	30	103	147	71	17.40		30	12.08		16
17	276.46	302	30	103	147	71	18.97		30	13.61		17
18	292.55	319	30	103	147	71	20.62	溶接構造	30	15.23		18
19	308.64	335	30	103	147	71	22.38		30	16.95		19
20	324.74	351	30	103	147	71	24.20		30	18.75		20
21	340.84	368	30	103	147	71	26.10		30	20.65	SS400	21
22	356.96	384	35	118	167	80	30.20		35	22.64		22
24	389.19	416	35	118	167	80	34.40		35	26.90		24
25	405.32	433	35	118	167	80	36.60		35	29.16		25
26	421.45	449	35	118	167	80	38.40		35	31.52		26
30	485.99	514	35	118	167	100	52.30	SS400	35	41.86		30
32	518.28	546	35	118	167	100	62.00	溶接構造	35	47.95		32
35	566.71	595	35	118	167	100	66.90		35	57.24		35
40	647.47	676	35	118	167	112	85.80		35	74.57		40
45	728.25	757	35	132	187	125	92.40		35	94.71		45
48	776.72	806	35	132	187	125			35	107.61		48
60	970.65	1,000	35	132	187	125	135.40		35	168.14		60

- Note: 1. Determine the required bore size less than the Max. value shown above taking strength reduction into consideration.  
 2. DID's finishing process is the basic application to the bore surface finishing for doubled sprockets of B type and C type.  
 3. For double C type sprockets, three or four types of bore size are available in 26 and larger number of teeth than that. The bigger standard bore is applied in case the required bore size ranges between the two types of bore size.  
 4. Heat treatment on teeth portion is available when requested.  
 5. Due to production reasons, S35C may be used for those with 13 ~ 21 teeth without notice.

Unit (mm)

Type	Number of teeth	Pitch dia. DP	Tip dia. Do	Bore d		Hub		Approx. weight (Kg)	Material
				Min.	Max.	(Dia.) DH	(Length) L		
				Double sprocket with hub on one side (B type), Both Sides (C type)					
B	13	212.27	237	45	90	155	120	23.9	
	14	228.30	253	45	90	165	120	27.7	
	15	244.33	269	45	100	180	120	32.3	
	16	260.39	286	50	105	195	140	41.5	
	17	276.46	302	60	120	210	150	49.3	
	18	292.55	319	60	130	225	160	59.2	
	19	308.64	335	65	140	240	170	69.8	
	20	324.74	351	65	150	260	180	84.2	
	21	340.84	368	65	150	260	180	89.8	
	22	356.95	384	65	150	260	180	95.7	Carbon steel or cast steel
	24	389.19	416	65	150	260	180	108.0	
26	421.45	449					141.0		
30	485.99	514	85	110	180	130	121.0		
32	518.28	546	110	145	225	170	128.0		
35	566.71	595	145	175	270	200	138.0		
38	615.17	644					150.0		
40	647.47	676					157.0		
45	728.25	757					214.0		
50	809.04	838					238.0		
55	889.84	919	85	110	180	130	264.0		
60	970.65	1,000	110	145	225	170	293.0		
65	1,051.47	1,081	145	180	270	200	322.0		
70	1,132.29	1,162	180	225	340	235	352.0		
75	1,213.11	1,243					386.0		
80	1,293.94	1,323					420.0		
90	1,455.61	1,485					502.0		



## DID 180 standard roller chain

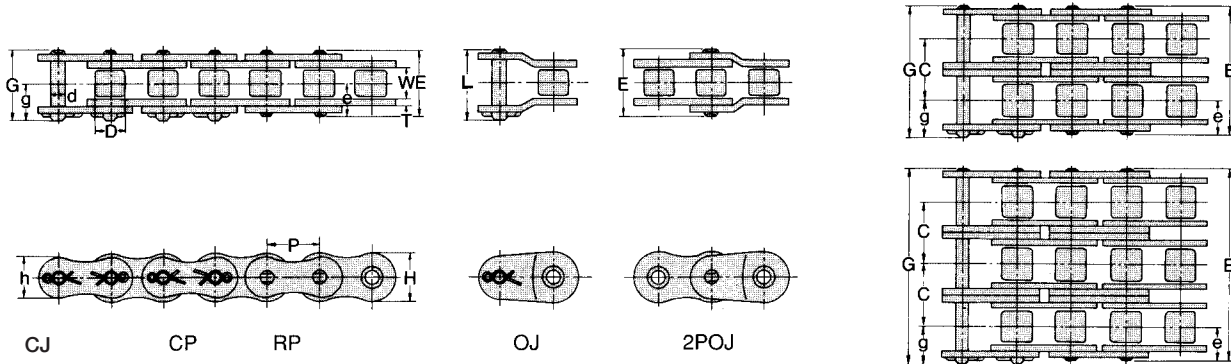

### Dimensions

Unit (mm)

Chain No.	Pitch	Roller Link Width	Roller dia.	Pin						Transverse Pitch	Plate				JIS		DID		DID		DID		Approx. Weight (kg/m)	
				D	d	E	G	L	e		g	C	T	H	h	Min. Tensile Strength	kgf	Min. Tensile Strength	kgf	Avg. Tensile Strength	kgf	Max. Allowable Load		kN
<b>DID180</b>	180					71.5	77.3	79.3								308.2	31,427	333.4	34,000	362	37,000	61.7	6,300	12.7
<b>DID180-2</b>	180-2					137.4	143.2	145.2								616.4	62,854	666.8	68,000	725	74,000	105	10,710	25.0
<b>DID180-3</b>	180-3	57.15	35.72	35.71	17.46	203.3	209.1	211.1	35.8	41.6	65.8	7.10	53.8	46.6	924.6	94,281	1,000	102,000	1,088	111,000	154	15,750	37.3	
<b>DID180-4</b>	180-4					269.1	274.9	276.9								1,232.8	125,708	1,333	136,000	1,451	148,000	203	20,790	49.6
<b>DID180-5</b>	180-5					334.9	340.7	342.7								1,541.0	157,135	1,667	170,000	1,814	185,500	240	24,570	61.9

Note: The values of average tensile strength and Max. allowable tension are for chains.

### Max. Kilowatt Ratings DID 180

Unit (kW)

No. of Teeth of Small Sprocket	Small Sprocket revolutions per minute (rpm) (See P132 for the details of type of lubrication A, B and C.)																										
	Type of Lubrication		10	25	50	100	150	200	250	300	350	400	450	500	550	600	650	700	750	800	850	900	950	1000	1050	1100	1150
<b>11</b>	<b>A</b>	4.51	10.3	19.2	35.8	51.6	66.9	81.7	96.3	111	111	92.7	79.2	68.6	60.2	53.4	47.8	43.1	39.1	35.7	32.8	30.2	28.0	26.0	24.3	<b>B</b>	<b>C</b>
<b>12</b>	<b>A</b>	4.96	11.3	21.1	39.4	56.7	73.5	89.8	106	122	126	106	90.2	78.2	68.6	60.9	54.5	49.1	44.6	40.7	37.4	34.4	31.9	29.6	27.6	<b>B</b>	<b>C</b>
<b>13</b>	<b>A</b>	5.40	12.3	23.0	42.9	61.8	80.1	97.9	115	133	142	119	102	88.2	77.4	68.6	61.4	55.4	50.3	45.9	42.1	38.8	36.0	33.4	15.0	<b>B</b>	<b>C</b>
<b>14</b>	<b>A</b>	5.85	13.4	24.9	46.5	67.0	86.8	106	125	144	159	133	114	98.5	86.5	76.7	68.6	61.9	56.2	51.3	47.1	43.4	40.2	37.4	<b>B</b>	<b>C</b>	
<b>15</b>	<b>A</b>	6.31	14.4	26.8	50.1	72.2	93.5	114	135	155	174	148	126	109	95.9	85.0	76.1	68.6	62.3	56.9	52.2	48.1	44.6	41.4	<b>B</b>	<b>C</b>	
<b>16</b>	<b>A</b>	6.76	15.4	28.8	53.7	77.4	100	123	144	166	187	163	139	120	106	93.7	83.8	75.6	68.6	62.7	57.5	53.0	49.1	38.3	<b>B</b>	<b>C</b>	
<b>17</b>	<b>A</b>	7.22	16.5	30.7	57.3	82.6	107	131	154	177	200	178	152	132	116	103	91.8	82.8	75.2	68.6	63.0	58.1	53.8	9.67	<b>B</b>	<b>C</b>	
<b>18</b>	<b>A</b>	7.68	17.5	32.7	61.0	87.9	114	139	164	188	212	194	166	144	126	112	100	90.2	81.8	74.8	68.6	63.3	58.6	<b>B</b>	<b>C</b>		
<b>19</b>	<b>A</b>	8.14	18.6	34.7	64.7	93.1	121	147	174	200	225	210	180	156	137	121	108	97.8	88.8	81.1	74.4	68.6	63.5	<b>B</b>	<b>C</b>		
<b>20</b>	<b>A</b>	8.60	19.6	36.6	68.3	98.4	128	156	184	211	238	227	194	168	148	131	117	106	95.9	87.6	80.4	74.1	38.4	<b>B</b>	<b>C</b>		
<b>21</b>	<b>A</b>	9.07	20.7	38.6	72.0	104	134	164	194	222	251	245	209	181	159	141	126	114	103	94.2	86.5	79.7	<b>B</b>	<b>C</b>			
<b>22</b>	<b>A</b>	9.54	21.8	40.6	75.8	109	141	173	204	234	264	262	224	194	170	151	135	122	111	101	92.7	85.5	<b>B</b>	<b>C</b>			
<b>23</b>	<b>A</b>	10.0	22.8	42.6	79.5	114	148	181	214	245	277	280	239	207	182	161	144	130	118	108	99.1	<b>B</b>	<b>C</b>				
<b>24</b>	<b>A</b>	10.5	23.9	44.6	83.2	120	155	190	224	257	290	299	255	221	194	172	154	139	126	115	<b>B</b>	<b>C</b>					
<b>25</b>	<b>A</b>	11.0	25.0	46.6	87.0	125	162	198	234	269	303	318	271	235	206	183	164	148	134	<b>B</b>	<b>C</b>						
<b>28</b>	<b>A</b>	12.4	28.2	52.7	98.3	142	183	224	264	304	342	377	321	279	245	217	194	<b>B</b>	<b>C</b>								
<b>30</b>	<b>A</b>	13.3	30.4	56.8	106	153	198	242	285	327	369	410	357	309	271	241	<b>B</b>	<b>C</b>									
<b>32</b>	<b>A</b>	14.3	32.6	60.8	114	164	212	259	305	351	395	440	393	340	299	265	<b>B</b>	<b>C</b>									
<b>35</b>	<b>A</b>	15.8	35.9	67.0	125	180	233	285	336	386	436	484	449	389	<b>B</b>	<b>C</b>											
<b>40</b>	<b>A</b>	18.2	41.5	77.4	144	208	270	330	388	446	503	559	549	<b>B</b>	<b>C</b>												
<b>45</b>	<b>A</b>	20.7	47.1	87.9	164	236	306	374	441	507	571	635	<b>B</b>	<b>C</b>													

Note: 1. Values in the above table are for simplex chain only. For multiplex chains, please multiply the coefficient of multi-strand. (See "Chain Selection" on P120).  
 2. Consult us when the ratings beyond the dotted line to rightward.



# DID 180 Standard Sprocket

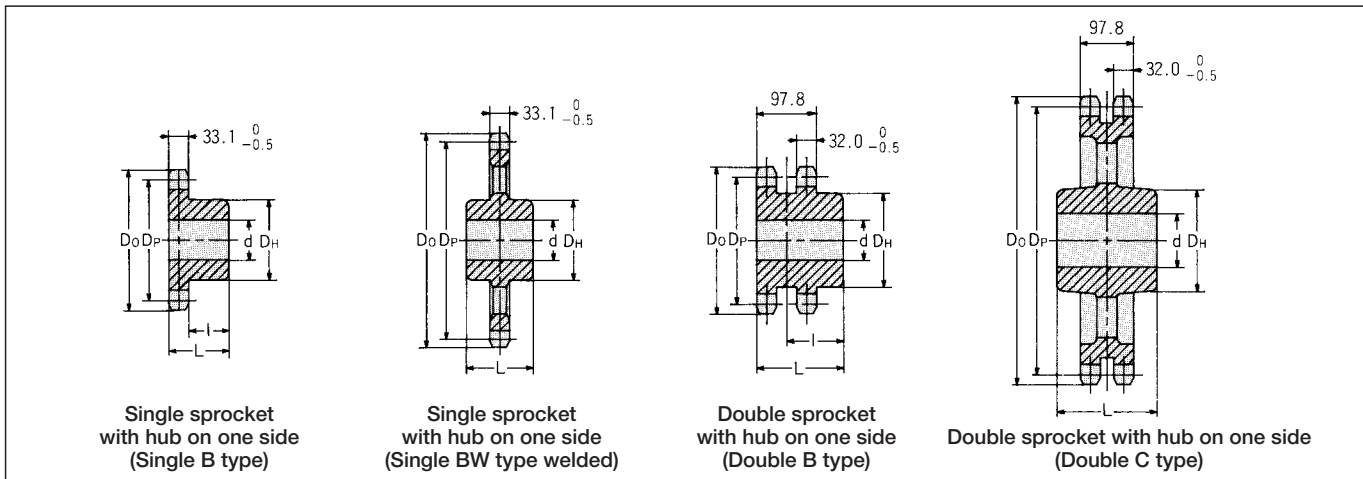

Single sprocket with hub on one side (Single B type)

Single sprocket with hub on one side (Single BW type welded)

Double sprocket with hub on one side (Double B type)

Double sprocket with hub on one side (Double C type)

Unit (mm)

Single sprocket with hub on one side (B type), Both Sides (C type)									
Type	Number of teeth	Pitch dia. Dp	Tip dia. Do	Bore d		Hub		Center position I	Material
				Min.	Max.	(Dia.) DH	(Length) L		
B	13	238.81	266	50	90	160	110	93.45	S35C, carbon steel or cast steel
	14	256.83	285	50	90	160	110	93.45	
	15	274.87	303	50	90	160	110	93.45	
	16	292.94	322	60	105	180	130	113.45	
	17	311.02	340	60	105	180	130	113.45	
	18	329.12	358	60	105	180	130	113.45	
	19	347.21	377	60	105	180	130	113.45	
	20	365.33	395	60	105	180	130	113.45	
C	21	383.45	413	70	120	195	140	Carbon steel or cast steel	
	22	401.58	432	70	120	195	140		
	24	437.84	468	70	120	195	140		
	26	474.13	505	70	120	195	140		
	30	546.74	578	70	120	195	140		
	32	583.06	615	70	120	195	140		
	35	637.55	669	70	120	195	140		
	38	692.06	724	80	135	215	170		
	40	728.41	760	80	135	215	170		
	45	819.28	852	80	135	215	170		
	50	910.17	943	80	135	215	170		
	55	1,001.07	1,034	80	135	215	170		
	60	1,091.98	1,125	80	135	215	170		
	65	1,182.90	1,216	90	150	250	190		
	70	1,273.83	1,307	90	150	250	190		
	75	1,364.75	1,398	90	150	250	190		
	80	1,455.69	1,489	90	150	250	190		
	90	1,637.56	1,671	90	150	250	190		

Unit (mm)

Double sprocket with hub on one side (B type), Both Sides (C type)									
Type	Number of teeth	Pitch dia. Dp	Tip dia. Do	Bore d		Hub		Center position I	Material
				Min.	Max.	(Dia.) DH	(Length) L		
B	13	238.81	266	60	100	170	130	81.1	Carbon steel or cast steel
	14	256.83	285	60	110	190	140	91.1	
	15	274.87	303	60	120	210	150	101.1	
	16	292.94	322	60	130	225	160	111.1	
	17	311.02	340	65	140	245	170	121.1	
	18	329.12	358	65	150	265	180	131.1	
	19	347.21	377	70	170	280	190	141.1	
	20	365.33	395	70	185	300	200	151.1	
C	21	383.45	413	70	185	300	200	Carbon steel or cast steel	
	22	401.58	432	70	185	300	200		
	24	437.84	468	70	185	300	200		
	26	474.13	505						
	30	546.74	578						
	32	583.06	615						
	35	637.55	669						
	38	692.06	724						
	40	728.41	760						
	45	819.28	852	110	145	225	170		
	50	910.17	943	145	180	270	200		
	55	1,001.07	1,034	180	225	340	235		
	60	1,091.98	1,125						
	65	1,182.90	1,216						
	70	1,273.83	1,307						
	75	1,364.75	1,398						
	80	1,455.69	1,489						
	90	1,637.56	1,671						

- Note: 1. Determine the required bore size less than the Max. value shown above taking strength reduction into consideration.  
 2. Given dimensions of bore and DH and L of hub to those with 21 teeth and larger is reference. Please consult with us about them when ordering.  
 3. DID's finishing process is the basic application to the bore surface finishing for double sprockets of B Type and C type.  
 4. For double C type sprockets, three or four types of bore size are available in 26 and larger number of teeth than that. The bigger standard bore is applied in case the required bore size ranges between the two types of bore size.  
 5. Heat treatment on teeth portion is available when requested.

## DID 200 standard roller chain

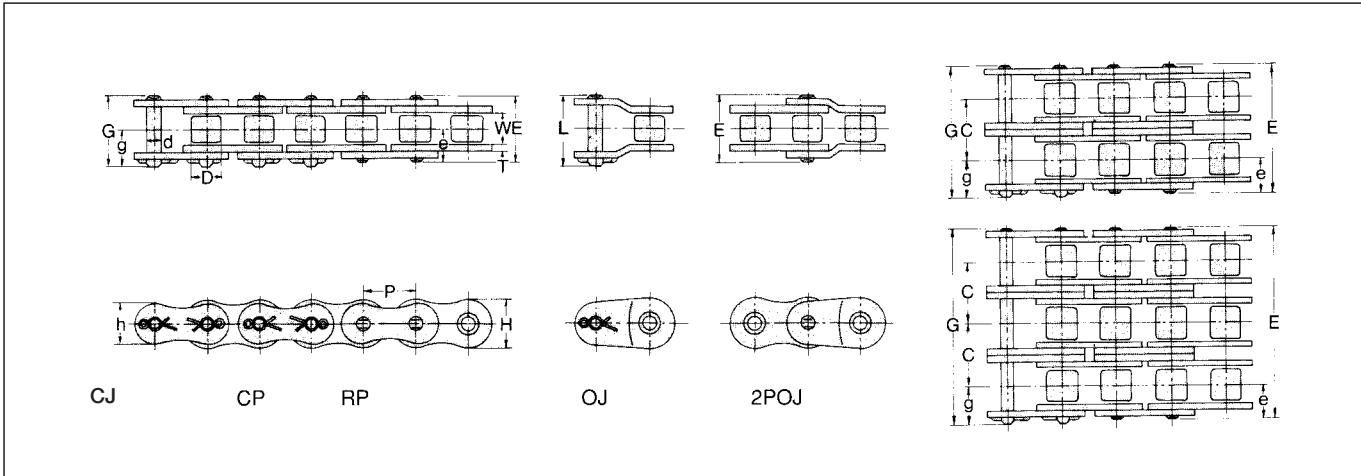

### Dimensions

Unit (mm)

Chain No.	Pitch	Roller Link Width W	Roller dia. D	Pin						Transvers e Pitch C	Plate			JIS Min. Tensile Strength		DID Min. Tensile Strength		DID Avg. Tensile Strength		DID Max. Allowable Load		Approx. Weight (kg/m)	
				d	E	G	L	e	g		T	h	kN	kgf	kN	kgf	kN	kgf	kN	kgf			
<b>DID200</b>	200				77.9	85.0	87.3								381.7	38,922	431.4	44,000	470	48,000	73.5	7,500	16.5
<b>DID200-2</b>	200-2				149.6	156.6	159.0								763.4	77,844	862.9	88,000	941	96,000	125	12,750	32.5
<b>DID200-3</b>	200-3	63.50	38.10	39.68	19.85	221.3	228.3	230.6	39.0		71.6	8.00	60.0	52.0	1,145.1	116,766	1,294	132,000	1,412	144,000	183	18,750	48.5
<b>DID200-4</b>	200-4					292.9	299.9	302.2							1,526.8	155,688	1,725	176,000	1,882	192,000	242	24,750	64.5
<b>DID200-5</b>	200-5					364.5	371.5	373.8							1,908.5	194,610	2,157	220,000	2,353	240,000	286	29,250	80.5

Note: The values of average tensile strength and Max. allowable tension are for chains.

### Max. Kilowatt Ratings DID 200

Unit (kW)

No. of Teeth of Small Sprocket	Type of Lubrication	Small Sprocket revolutions per minute (rpm) (See P132 for the details of type of lubrication A, B and C.)																																		
		10							15							20							30							40						
		A							B							C							C													
11	5.86 8.45 10.9 15.8	20.4 25.0 29.4 38.1	46.6 67.1 86.9 106	125 144	120	101 74.7 65.5 58.1	52.0 46.9 42.6 38.9	35.7																												
12	6.44 9.28 12.0 17.3	22.4 27.4 32.3 41.9	51.2 73.7 95.5 117	138 158	137	115 85.1 74.7 66.2	59.2 53.4 48.5 44.3	40.6																												
13	7.02 10.1 13.1 18.9	24.5 29.9 35.2 45.6	55.8 80.4 104	127 150	172	155	130 95.9 84.2 74.7	66.8 60.2 54.7 49.9	45.8																											
14	7.61 11.0 14.2	20.5 26.5 32.4 38.2	49.4 60.4 87.1 113	138 162	187	173	145 107 94.1 83.4	74.7 67.3 61.1 55.8	30.2																											
15	8.20 11.8 15.3	22.0 28.5 34.9 41.1	53.3 65.1 93.8 122	149 175	201	192	161 119 104 92.5	82.8 74.7 67.8 61.9	1.58																											
16	8.79 12.7 16.4	23.6 30.6 37.4 44.1	57.1 69.8 101	130 159	188	216	211 177 131 115	102 91.2 82.2 74.7	68.2																											
17	9.38 13.5 17.5	25.2 32.7 39.9 47.1	61.0 74.5 107	139 170	200	230	231 194 143 126	112 99.9 90.1 81.8	74.7																											
18	9.98 14.4 18.6	26.8 34.8 42.5 50.1	64.9 79.3 114	148 181	213 245	252	211 156 137 122	109 98.1 89.1 53.1																												
19	10.6 15.2 19.8	28.4 36.9 45.0 53.1	68.8 84.1 121	157 192	226 260	273	229 169 149 132	118 106 96.6																												
20	11.2 16.1 20.9	30.1 38.9 47.6 56.1	72.7 88.8 128	166 203	239 274	293	247 183 161 142	127 115																												
21	11.8 17.0 22.0	31.7 41.1 50.2 59.1	76.6 93.6 135	175 214	252 289	317	266 197 173 153	137																												
22	12.4 17.9 23.1	33.3 43.2 52.8 62.2	80.6 98.5 142	184 225	265 304	340	285 211 185 164	147																												
23	13.0 18.7 24.3	35.0 45.3 55.4 65.2	84.5 103 149	193 236	278 319	360	305 226 198 176																													
24	13.6 19.6 25.4	36.6 47.4 58.0 68.3	88.5 108 156	202 247	291 334	377	325 241 211 187																													
25	14.2 20.5 26.6	38.3 49.6 60.6 71.4	92.5 113 163	211 258	304 349	394	346 256 224																													

Note: 1. Value in the above table is for simplex chain only. For multiplex chains, please apply the coefficient of Multi-strand. (Please refer to Chain selection on P.120).

2. Consult us when the ratings beyond the dotted line to rightward.

# DID 200 Standard Sprocket

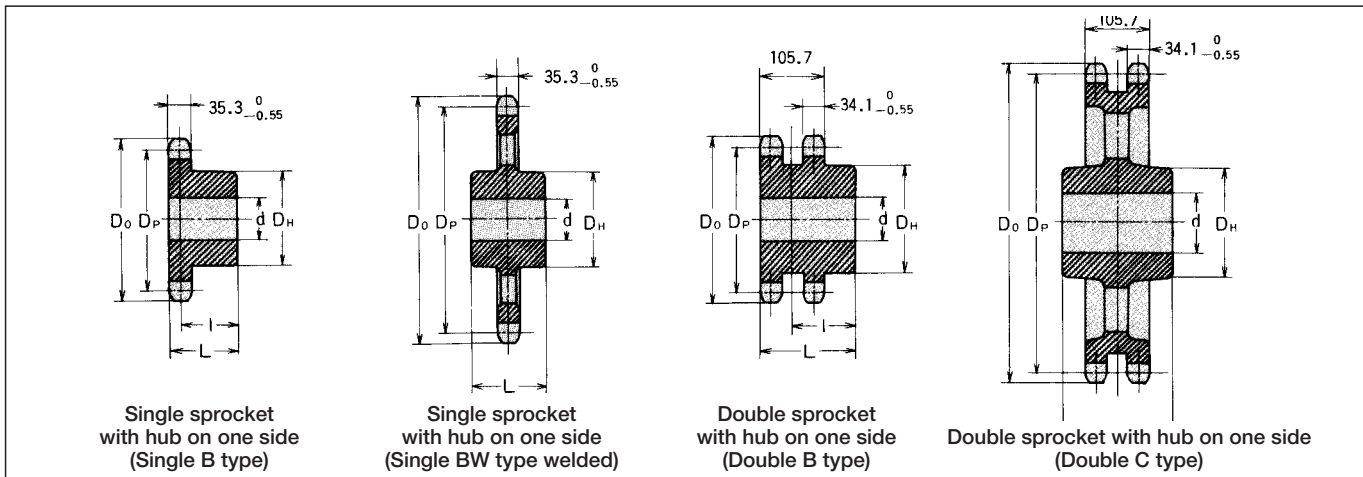

Unit (mm)

Single sprocket with hub on one side (B type), Both Sides (C type)

Type	Number of teeth	Pitch dia. Dp	Tip dia. Do	Bore d		Hub		Center position I	Approx. weight (Kg)	Material
				Min.	Max.	(Dia.) Dh	(Length) L			
B	13	265.34	296	60	100	170	120	102.40	29.0	Carbon steel or cast steel
	14	285.37	316	60	100	170	120	102.40	31.5	
	15	305.42	337	60	100	170	120	102.40	34.2	
	16	325.49	357	70	120	195	140	122.40	45.4	
	17	345.58	378	70	120	195	140	122.40	48.5	
	18	365.68	398	70	120	195	140	122.40	51.8	
	19	385.79	419	70	120	195	140	122.40	55.3	
	20	405.92	439	70	120	195	140	122.40	59.0	
	21	426.05	459	70	120	195	140		63.4	
	22	446.20	480	70	120	195	140		66.8	
24	486.49	520	70	120	195	140		73.9		
26	526.81	561	70	120	215	150		89.3		
30	607.49	642	70	120	215	150		105		
32	647.85	683	70	120	215	150		113		
35	708.39	744	70	120	215	150		113		
38	768.96	804	80	150	250	170		141		
40	809.34	845	80	150	250	170		162		
45	910.31	946	80	150	250	170		180		
50	1,011.30	1,047	80	150	250	170		200		
55	1,112.30	1,149	80	150	250	170		221		
60	1,213.31	1,250	90	150	250	190		251		
65	1,314.34	1,351	90	150	250	190		271		
70	1,415.36	1,452	90	150	250	190		296		
75	1,516.39	1,553	90	170	290	190		350		
80	1,617.43	1,654	90	170	290	190		377		
90	1,819.51	1,856	90	170	290	190		418		

Unit (mm)

Double sprocket with hub on one side (B type), Both Sides (C type)

Type	Number of teeth	Pitch dia. Dp	Tip dia. Do	Bore d		Hub		Center position I	Approx. weight (Kg)	Material
				Min.	Max.	(Dia.) Dh	(Length) L			
B	13	265.34	296	60	105	190	140	87.15	43.0	Carbon steel or cast steel
	14	285.37	316	60	115	205	150	97.15	52.6	
	15	305.42	337	60	130	225	160	107.15	64.9	
	16	325.49	357	70	145	245	170	117.15	77.8	
	17	345.58	378	70	160	265	190	137.15	98.0	
	18	365.68	398	70	175	285	200	147.15	117	
	19	385.79	419	70	190	305	210	157.15	133	
	20	405.92	439	70	190	305	210	157.15	149	
	21	426.05	459	70	190	305	210	157.15	159	
	22	446.20	480	70	190	305	210		171	
	24	486.49	520	70	190	305	210		181	
26	526.81	561						201		
30	607.49	642						224		
32	647.85	683						237		
35	708.39	744						256		
38	768.96	804						284		
40	809.34	845						296		
C	45	910.31	946	110	145	225	170		336	
	50	1,011.30	1,047	145	180	270	200		380	
	55	1,112.30	1,149	180	225	340	235		422	
	60	1,213.31	1,250						473	
	65	1,314.34	1,351						528	
	70	1,415.36	1,452						582	
	75	1,516.39	1,553						643	
	80	1,617.43	1,654						704	
	90	1,819.51	1,856						839	

Note: 1. Determine the required bore size less than the Max. value shown above taking strength reduction into consideration.  
 2. DID's finishing process is the basic application to the bore surface finishing for double sprockets of B type and C type.  
 3. For double C type sprockets, three or four types of bore size are available in 26 and larger number of teeth than that. The bigger standard bore is applied in case the required bore size ranges between the two types of bore size.

## DID 240 standard roller chain

Roller Chains for Power Transmission  
Standard Roller Chain

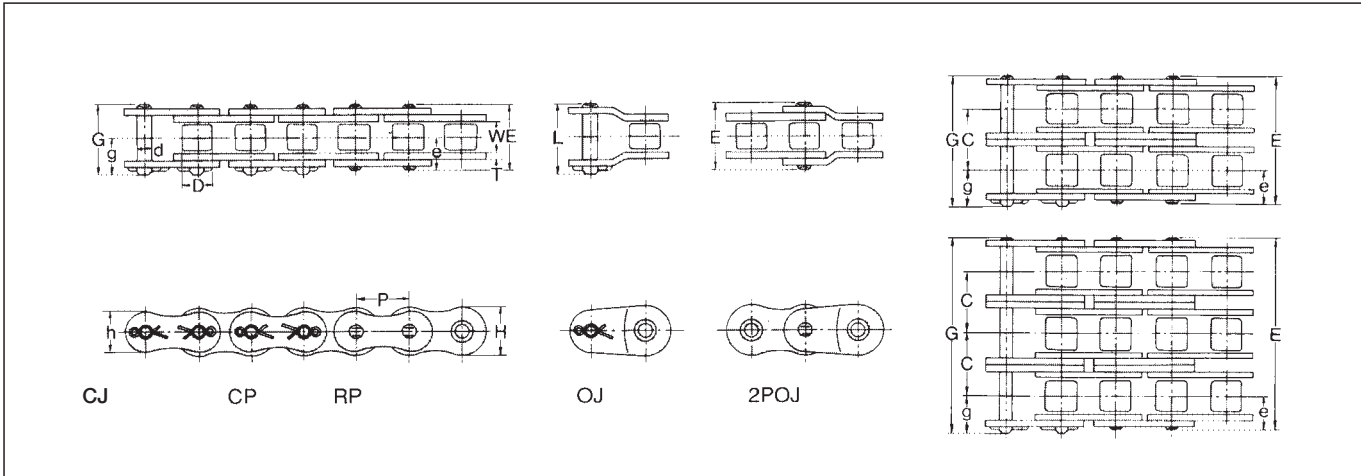

### Dimensions

Unit (mm)

Chain No.	Pitch	Roller Link Width W	Roller dia. D	Pin						Transverse Pitch C	Plate				JIS Min. Tensile Strength		DID Min. Tensile Strength		DID Avg. Tensile Strength		DID Max. Allowable Load		Approx. Weight (kg/m)
				d	E	G	L	e	g		T	H	h	kN	kgf	kN	kgf	kN	kgf	kN	kgf		
<b>DID240</b>	240				95.2	102.9	105.4								550.4	56,125	622.7	63,500	686	70,000	99.0	10,100	23.3
<b>DID240-2</b>	240-2				183.1	190.8	193.3								1,100.8	112,250	1,245	127,000	1,370	140,000	168	17,170	46.0
<b>DID240-3</b>	240-3	76.20	47.63	47.63	23.81	270.9	278.6	281.1	47.7	55.3	87.8	9.50	71.5	62.0	1,651.2	168,375	1,868	190,500	2,050	210,000	247	25,250	68.7
<b>DID240-4</b>	240-4					358.7	366.4	368.9							2,201.6	224,500	2,490	254,000	2,740	280,000	326	33,330	91.3
<b>DID240-5</b>	240-5					446.5	454.2	456.7							2,752.0	280,625	3,113	317,500	3,430	350,000	386	39,390	114

Note: The values of average tensile strength and Max. allowable tension are for chains.

### Max. Kilowatt Ratings DID 240

Unit (kW)

No. of Teeth of Small Sprocket	Type of Lubrication	Small Sprocket revolutions per minute (rpm) (See P132 for the details of type of lubrication A, B and C.)																																		
		5							10							15							20							25						
		A							B							C							C													
11	5.06 9.44 13.6 17.6 21.5 25.4 32.9 40.2 47.4 61.4 75.0 91.7 108 124 140 171 202 170 139 117 99.6 86.4 75.8 67.2																																			
12	5.56 10.4 14.9 19.4 23.7 27.9 36.1 44.2 52.0 67.4 82.4 101 119 136 154 188 222 194 159 133 114 98.4 86.4 44.4																																			
13	6.06 11.3 16.3 21.1 25.8 30.4 39.4 48.2 56.7 73.5 89.9 110 129 149 168 205 242 219 179 150 128 111 97.4 15.7																																			
14	6.57 12.3 17.7 22.9 28.0 32.9 42.7 52.2 61.5 79.6 97.3 119 140 161 182 222 262 244 200 168 143 124 109																																			
15	7.07 13.2 19.0 24.6 30.1 35.5 46.0 56.2 66.2 85.8 105 128 151 174 196 239 282 271 222 186 159 138 121																																			
16	7.59 14.2 20.4 26.4 32.3 38.1 49.3 60.3 71.0 92.0 112 138 162 186 210 256 302 298 244 205 175 152 130																																			
17	8.10 15.1 21.8 28.2 34.5 40.6 52.6 64.3 75.8 98.2 120 147 173 199 224 274 323 327 268 224 191 166 101																																			
18	8.61 16.1 23.2 30.0 36.7 43.2 56.0 68.4 80.6 105 128 156 184 211 238 291 343 356 292 244 209 181 72.6																																			
19	9.13 17.0 24.6 31.8 38.9 45.8 59.3 72.5 85.5 111 135 165 195 224 253 309 364 386 316 265 226 196 44.0																																			
20	9.65 18.0 26.0 33.6 41.1 48.4 62.7 76.7 90.4 117 143 175 206 237 267 326 385 417 341 286 244 212 15.3																																			
21	10.2 19.0 27.4 35.4 43.3 51.0 66.0 80.8 95.2 123 151 184 217 250 281 344 405 449 367 308 263 204																																			
22	10.7 20.0 28.8 37.3 45.5 53.7 69.5 85.0 100 130 159 194 228 262 296 362 426 481 394 330 282 176																																			
23	11.2 21.0 30.2 39.1 47.8 56.3 72.9 89.2 105 136 165 203 240 275 311 380 447 514 421 353 301 147																																			
24	11.8 21.9 31.6 40.9 50.0 59.0 76.4 93.4 110 143 174 213 251 288 325 397 468 538 449 376 321																																			
25	12.3 22.9 33.0 42.8 52.3 61.6 79.8 97.6 115 149 182 223 262 301 340 415 489 562 477 400 328																																			

Note: 1. Values in the above table are for simplex chain only. For multiplex chains, please multiply the coefficient of multi-strand. (See "Chain Selection" on P120).

2. Consult us when the ratings beyond the dotted line to rightward.

# DID 240 Standard Sprocket

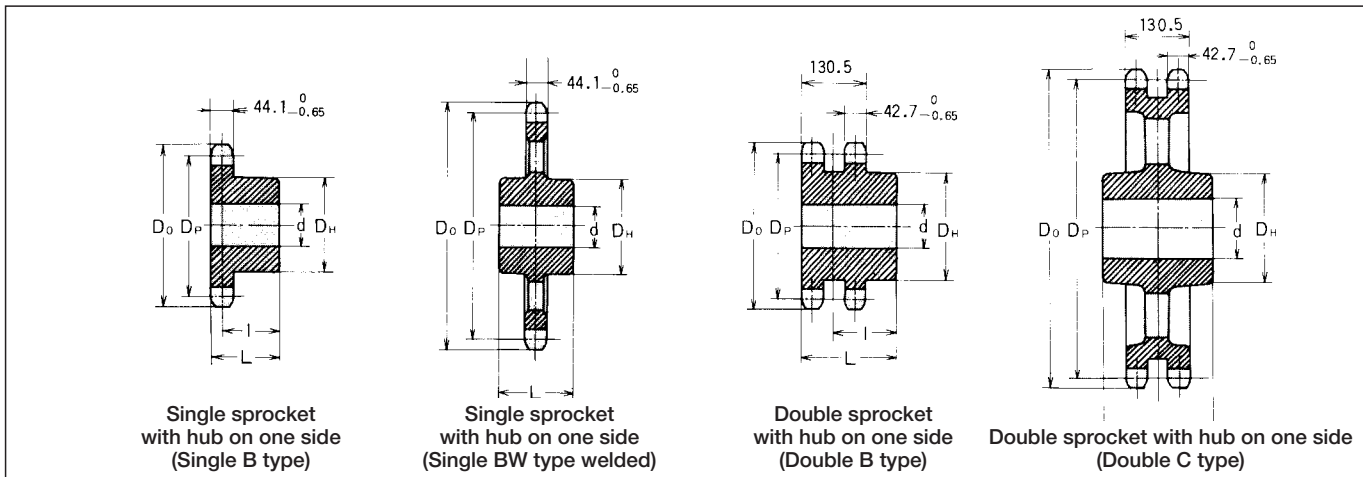

Unit (mm)

Single sprocket with hub on one side (B type), Both Sides (C type)

Type	Number of teeth	Pitch dia. Dp	Tip dia. Do	Bore d		Hub		Center position I	Approx. weight (Kg)	Material
				Min.	Max.	(Dia.) Dh	(Length) L			
B	13	318.41	355	70	120	195	150	127.95	49.9	Carbon steel or cast steel
	14	342.44	380	70	120	195	150	127.95	54.5	
	15	366.50	404	70	120	195	150	127.95	59.4	
	16	390.59	429	80	135	230	170	147.95	79.1	
	17	414.70	453	80	135	230	170	147.95	84.7	
	18	438.82	478	80	135	230	170	147.95	90.3	
	19	462.95	502	80	135	230	170	147.95	92.0	
	20	487.11	527	80	150	250	170	147.95	111	
	21	511.26	551	80	150	250	170		121	
	22	535.43	576	80	150	250	170		128	
24	583.79	625	80	135	215	170		126		
26	632.17	673	80	135	215	170		140		
30	728.99	771	80	135	215	170		155		
32	777.42	819	80	135	215	170		164		
35	850.07	892	90	150	250	190		202		
38	922.75	965	90	150	250	190		253		
40	971.21	1,014	90	150	250	190		271		
45	1,092.37	1,135	90	150	250	190		307		
50	1,213.56	1,257	90	150	250	190		348		
55	1,334.76	1,378	90	150	250	190		391		
60	1,455.98	1,500	100	170	290	200		468		
65	1,577.20	1,621	100	170	290	200		509		
70	1,698.44	1,742	100	170	290	200		558		
75	1,819.67	1,864	100	200	330	200		636		
80	1,940.91	1,985	100	200	330	200		696		
90	2,183.41	2,228	100	200	330	200		781		

Unit (mm)

Double sprocket with hub on one side (B type), Both Sides (C type)

Type	Number of teeth	Pitch dia. Dp	Tip dia. Do	Bore d		Hub		Center position I	Approx. weight (Kg)	Material
				Min.	Max.	(Dia.) Dh	(Length) L			
B	13	318.41	355	70	130	225	170	104.75	75.3	Carbon steel or cast steel
	14	342.44	380	70	145	250	170	104.75	89.9	
	15	366.50	404	70	160	270	190	124.75	113	
	16	390.59	429	70	175	290	200	134.75	135	
	17	414.70	453	70	190	310	210	144.75	159	
	18	438.82	478	70	210	340	210	144.75	185	
	19	462.95	502	70	210	340	210	144.75	201	
	20	487.11	527	70	210	340	210	144.75	220	
	21	511.26	551	70	210	340	210	144.75	238	
	22	535.43	576	70	210	340	210		260	
24	583.79	625						255		
26	632.17	673						265		
30	728.99	771						322		
32	777.42	819						352		
35	850.07	892						390		
38	922.75	965						432		
40	971.21	1,014						462		
45	1,092.37	1,135	110	145	225	170		534		
50	1,213.56	1,257	145	180	270	200		624		
55	1,334.76	1,378	180	225	340	235		715		
60	1,455.98	1,500						806		
65	1,577.20	1,621						911		
70	1,698.44	1,742						1,030		
75	1,819.67	1,864						1,130		
80	1,940.91	1,985						1,260		
90	2,183.41	2,228						1,550		

Note: 1. Determine the required bore size less than the Max. value shown above taking strength reduction into consideration.  
 2. DID's finishing process is the basic application to the bore surface finishing for double sprockets of B type and C type.  
 3. For double C type sprockets, three or four types of bore size are available in 26 and larger number of teeth than that. The bigger standard bore is applied in case the required bore size ranges between the two types of bore size.

## Strong chains suitable for use in various conditions

		HI-PWR-S Roller Chain	HK Roller Chain
Roller Chains for Power Transmission High-strength Roller Chain Series	<b>Name</b>		
	<b>Features</b>	① Higher fatigue strength and shock strength are provided without changing dimensions from standard roller chain ② Oval figured link-plates are provided	① Thickness of inner and outer plates are the same as the link-plates of the next size larger standard chain ② Allows the selection of a chain one size smaller than would be necessary
	<b>Functions</b>	<div style="display: flex; justify-content: space-around;"> <div style="border: 1px solid black; padding: 2px; text-align: center;">                         Allowable Load  <b>130%</b> </div> <div style="border: 1px solid black; padding: 2px; text-align: center;">                         Tensile strength index  <b>110%</b> </div> <div style="border: 1px solid black; padding: 2px; text-align: center;">                         Temperature Range in Use                          -10°C~80°C                     </div> </div>	<div style="display: flex; justify-content: space-around;"> <div style="border: 1px solid black; padding: 2px; text-align: center;">                         Allowable Load  <b>115%</b> </div> <div style="border: 1px solid black; padding: 2px; text-align: center;">                         Tensile strength index  <b>120%</b> </div> <div style="border: 1px solid black; padding: 2px; text-align: center;">                         Temperature Range in Use                          -10°C~80°C                     </div> </div>
	<b>Main uses</b>	<div style="display: flex; justify-content: space-around;"> <div style="border: 1px solid black; border-radius: 50%; padding: 5px; text-align: center;">CONST- RUCTION</div> <div style="border: 1px solid black; border-radius: 50%; padding: 5px; text-align: center;">AGRICULTURE</div> <div style="border: 1px solid black; border-radius: 50%; padding: 5px; text-align: center;">OUTDOOR</div> </div>	<div style="display: flex; justify-content: space-around;"> <div style="border: 1px solid black; border-radius: 50%; padding: 5px; text-align: center;">PETROLIUM</div> <div style="border: 1px solid black; border-radius: 50%; padding: 5px; text-align: center;">CONST- RUCTION</div> <div style="border: 1px solid black; border-radius: 50%; padding: 5px; text-align: center;">FORESTRY</div> <div style="border: 1px solid black; border-radius: 50%; padding: 5px; text-align: center;">(MACHINE)</div> <div style="border: 1px solid black; border-radius: 50%; padding: 5px; text-align: center;">AGRICULTURE</div> </div>

■ **Table of Ultimate Power Chain Series**

Chain No.	HI-PWR-S	HK	HI-PWR-SHK
<b>DID 50</b>	-	HK	-
<b>DID 60</b>	-	HK	-
<b>DID 80</b>	HI-PWR-S	HK	HI-PWR-SHK
<b>DID 100</b>	HI-PWR-S	HK	HI-PWR-SHK
<b>DID 120</b>	HI-PWR-S	HK	HI-PWR-SHK
<b>DID 140</b>	HI-PWR-S	HK	HI-PWR-SHK
<b>DID 160</b>	HI-PWR-S	HK	HI-PWR-SHK
<b>DID 180</b>	HI-PWR-S	HK	HI-PWR-SHK
<b>DID 200</b>	HI-PWR-S	HK	HI-PWR-SHK
<b>DID 240</b>	HI-PWR-S	HK	HI-PWR-SHK



<b>HI-PWR-SHK Roller Chain</b>		<b>Name</b>
		
<p>① Both thicker link plates and oval figured link plates are provided                  ② Thus it makes it possible to have maximum tensile strength and allowable load</p>		<b>Features</b>
<div style="display: flex; justify-content: space-around; align-items: center;"> <div style="border: 1px solid black; padding: 5px; text-align: center;">                     Allowable Load  <b>150%</b> </div> <div style="border: 1px solid blue; padding: 5px; text-align: center; color: blue;">                     Tensile strength index  <b>125%</b> </div> <div style="border: 1px solid red; padding: 5px; text-align: center; color: red;">                     Temperature Range in Use                      -10°C ~ 80°C                 </div> </div>		<b>Functions</b>
<div style="display: flex; justify-content: space-around;"> <div style="border: 1px solid black; border-radius: 50%; padding: 10px; width: 40px; text-align: center;">CONST- RUCTION</div> <div style="border: 1px solid black; border-radius: 50%; padding: 10px; width: 40px; text-align: center;">EXCAVATION</div> <div style="border: 1px solid black; border-radius: 50%; padding: 10px; width: 40px; text-align: center;">MINING</div> </div>		<b>Main uses</b>

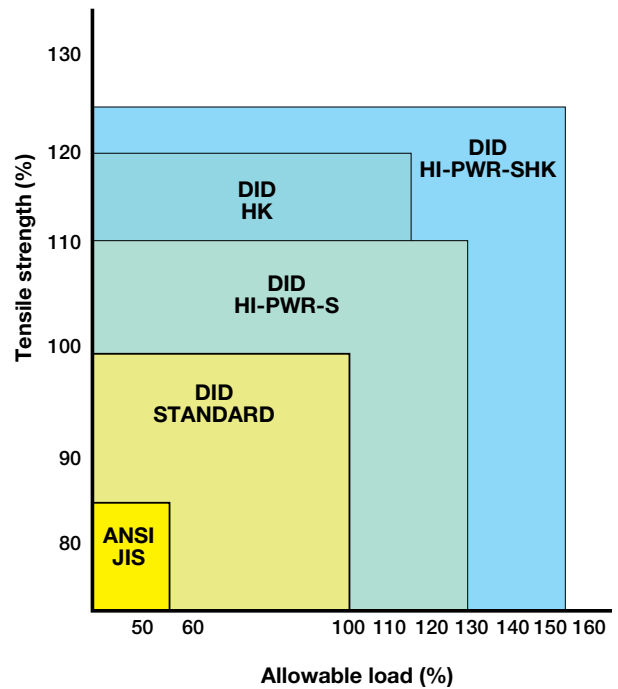

## ■ Symbols

<b>Functions</b>	<div style="border: 1px solid black; padding: 5px; text-align: center;">                     Allowable Load  <b>130%</b> </div> Allowable load index <small>(Compared to standard chains)</small>	<div style="border: 1px solid blue; padding: 5px; text-align: center; color: blue;">                     Tensile strength index  <b>110%</b> </div> Tensile strength index <small>(Compared to standard chains)</small>	<div style="border: 1px solid red; padding: 5px; text-align: center; color: red;">                     Temperature Range in Use                      -10°C ~ 80°C                 </div> Allowable ambient temperature
<b>Main uses</b>	<div style="border: 1px solid black; border-radius: 50%; padding: 10px; width: 40px; text-align: center;">CONST- RUCTION</div> Feed and drive in construction machines	<div style="border: 1px solid black; border-radius: 50%; padding: 10px; width: 40px; text-align: center;">OUTDOOR</div> Feed and drive in outdoor equipment	<div style="border: 1px solid black; border-radius: 50%; padding: 10px; width: 40px; text-align: center;">PETROLEUM</div> Feed and drive of petroleum-related equipment
	<div style="border: 1px solid black; border-radius: 50%; padding: 10px; width: 40px; text-align: center;">FORESTRY</div> Feed and drive of forestry-related equipment	<div style="border: 1px solid black; border-radius: 50%; padding: 10px; width: 40px; text-align: center;">MACHINE</div> Feed and drive of industrial machinery equipment	<div style="border: 1px solid black; border-radius: 50%; padding: 10px; width: 40px; text-align: center;">AGRICULTURE</div> Drive of agricultural machines
	<div style="border: 1px solid black; border-radius: 50%; padding: 10px; width: 40px; text-align: center;">EXCAVATION</div> Drive of excavation machines	<div style="border: 1px solid black; border-radius: 50%; padding: 10px; width: 40px; text-align: center;">MINING</div> Feed and drive of mining equipment	

## HI-PWR-S Type Roller Chains



### High power roller chains with improved fatigue strength and impact strength

HI-PWR-S roller chains are enhanced in fatigue strength and impact strength without changing the dimension in the pin length direction of standard roller chains. Plates are enlarged, and the machining accuracy and assembling accuracy of components are improved. The roller chains hold high transmission efficiency for applications from low to high speeds and are powerful enough to withstand long-term use.

#### Recommended uses

- Compared to standard roller chains, HI-PWR-S roller chains are higher in maximum kilowatt rating by about 30 percent in a medium to low speed range. They exhibit excellent capability in places where large shock loads are applied, drive units for frequent start/stop, and also in high speed applications.

#### <Examples>

- Civil engineering machines such as skid steer, trenchers, trucks, cranes, agitating trucks, forklifts and drive units for conveyors, elevators, stackers, etc.

Maximum kilowatt rating diagram

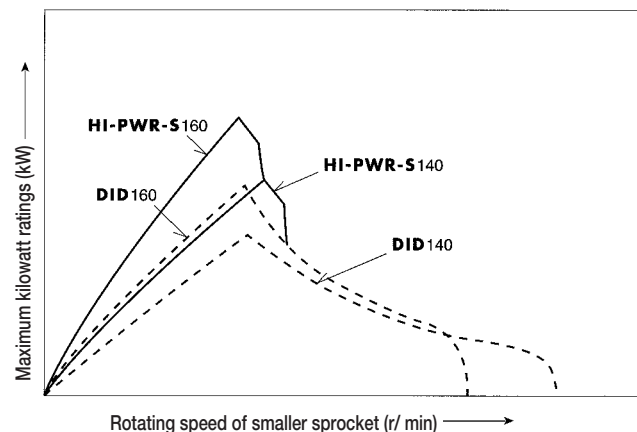

## Selection of chains

In general, select your chain with reference to "Designing of Chain Transmission" (P120~126) and also to the tables of "Drive Performance" and "Dimensions" of HI-PWR-S type roller chains (P52~59)

However, only for a special case of low speed and less shock, "Low-speed selection" (P121) is also applicable.

## Sprockets

HI-PWR-S Roller chains and ANSI standard chains are the same in basic dimensions. Use ANSI standard sprockets.

## Connecting links and offset links

Use H connecting links for HI-PWR-S. In an H connecting link, the pins are lightly interference-fitted with the connecting plate. For the connection between the connecting plate and the connecting pins, spring pins are used instead of cotter pins for a standard roller chain.

The center plates of an H connecting link for multiplex chain has bushings pressed in.

HI-PWR-S roller chains do not have any offset link. Use an even number of links.

Never make the holes of the connecting plate larger and never make the pins thinner to facilitate the work for fitting the pins into the connecting plate, since otherwise the fatigue strength will be lowered.

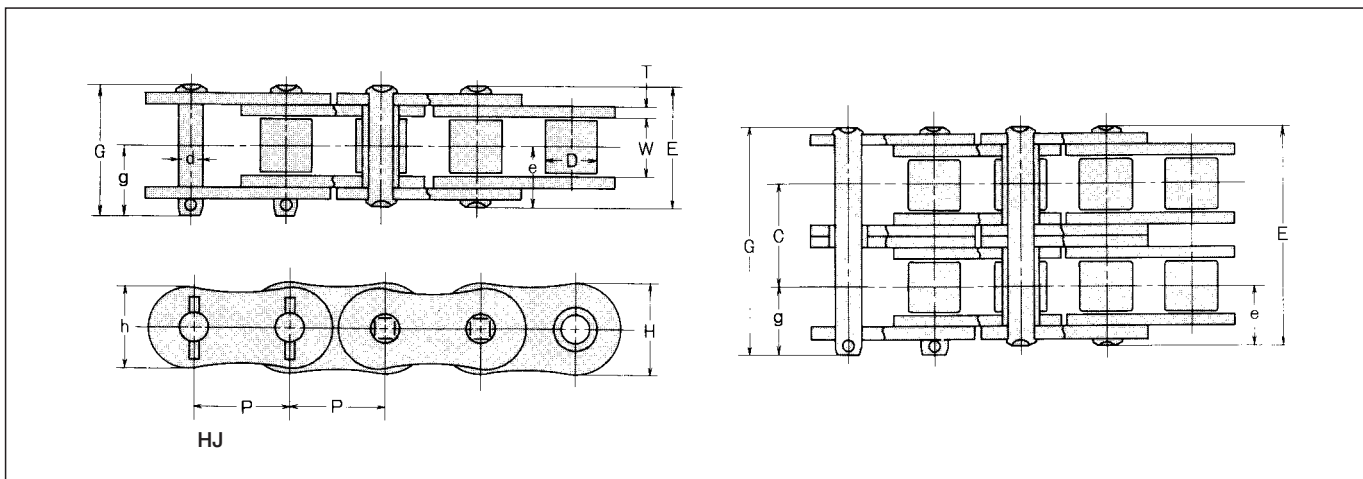

## Dimensions

Unit (mm)

Chain No.		Pitch <b>P</b>	Roller link width <b>W</b>	Roller dia. <b>D</b>	Pin					Transverse pitch <b>C</b>	Plate			DID		DID		DID		Approx. Weight (kg/m)
<b>DID</b>	<b>ANSI*</b>				<b>d</b>	<b>E</b>	<b>G</b>	<b>e</b>	<b>g</b>		<b>T</b>	<b>H</b>	<b>h</b>	Avg. tensile strength	Max. allowable load	Max. allowable load	Max. allowable load	Max. allowable load		
<b>DID HI-PWR-S 80</b>	80	25.40	15.88	15.88	7.94	32.6	35.4	16.4	19.0	29.3	3.2	24.1	20.8	75.51	7,700	84	8,600	18.6	1,900	2.82
<b>DID HI-PWR-S 100</b>	100	31.75	19.05	19.05	9.54	39.5	42.5	19.8	22.7	35.8	4.0	30.1	26.0	116.7	11,900	127	13,000	30.4	3,100	4.18
<b>DID HI-PWR-S 120</b>	120	38.10	25.40	22.23	11.11	49.7	53.0	24.9	28.2	45.4	4.8	36.2	31.2	171.6	17,500	186	19,000	40.2	4,100	6.12
<b>DID HI-PWR-S 140</b>	140	44.45	25.40	25.40	12.71	53.6	58.4	26.8	31.7	48.9	5.6	42.2	36.3	225.5	23,000	245	25,000	53.9	5,500	7.71
<b>DID HI-PWR-S 160</b>	160	50.80	31.75	28.58	14.29	63.6	68.2	31.9	36.5	58.5	6.4	48.2	41.4	288.3	29,400	313	32,000	70.6	7,200	10.5
<b>DID HI-PWR-S 180</b>	180	57.15	35.72	35.71	17.46	71.5	77.3	35.8	41.6	65.8	7.1	54.2	46.6	378.5	38,600	412	42,000	83.3	8,500	14.4
<b>DID HI-PWR-S 200</b>	200	63.50	38.10	39.68	19.85	77.9	85.0	39.0	46.0	71.6	8.0	60.2	52.0	459.9	46,900	500	51,000	98.1	10,000	17.5
<b>DID HI-PWR-S 240</b>	240	76.20	47.63	47.63	23.81	95.2	102.9	47.7	55.3	87.8	9.5	72.2	62.0	666.8	68,000	725	74,000	132.4	13,500	24.7

Note: 1. The values of average tensile strength and maximum allowable load are for chains.

2. Ask us for the delivery time.

3. \*Equivalent to ANSI

## DID HI-PWR-S80 (Please refer to P33 for sprocket)

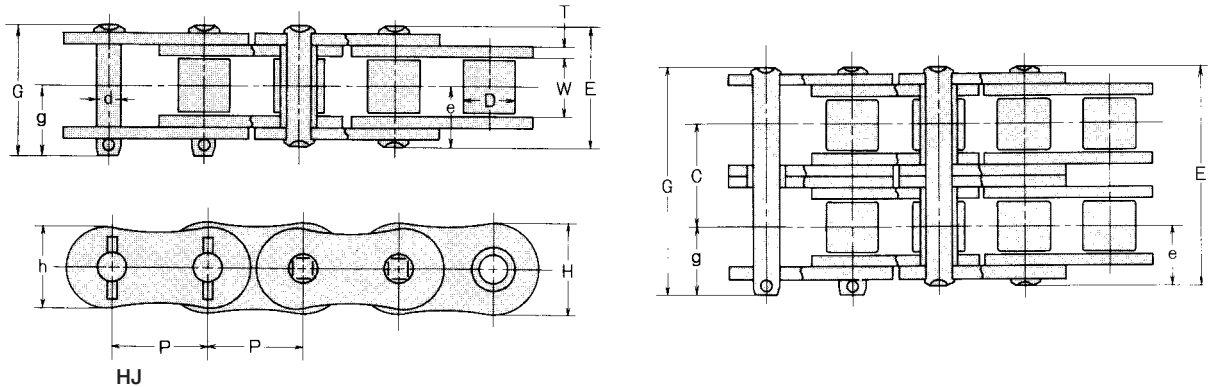

### Dimensions

Unit (mm)

Chain No.	Pitch	Roller link width W	Roller dia. D	Pin					Transverse Pitch C	Plate				DID Min. Tensile Strength		DID Avg. Tensile Strength		DID Max. Allowable Load		Approx. Weight (kg/m)	
				d	E	G	e	g		T	H	h	kN	kgf	kN	kgf	kN	kgf			
DID HI-PWR-S 80	80														75.51	7,700	84	8,600	18.6	1,900	2.82
DID HI-PWR-S 80-2	80-2	25.40	15.88	15.88	7.94	61.9	64.7	16.4	19.0	29.3	3.2	24.1	20.8		151.0	15,400	168	17,200	31.6	3,230	5.61
DID HI-PWR-S 80-3	80-3														226.5	23,100	253	25,800	46.5	4,750	8.24

Note: The values of average tensile strength and maximum allowable tension are for chains.

\*Equivalent to ANSI

### Max. kilowatt Ratings HI-PWR-S80

Unit (kW)

No. of Teeth of Small Sprocket	Type of Lubrication	Small sprocket rpm (Refer to P132 for the details of lubrication A, B and C.)									
		25	50	100	200	300	400	500	700	900	1000
		A			B			C			
11		1.47	2.75	5.13	9.57	13.8	17.9	21.8	29.6	24.0	
12		1.62	3.02	5.63	10.5	15.1	19.6	24.0	32.5	27.3	
13		1.76	3.29	6.14	11.5	16.5	21.4	26.2	35.4	30.8	
14		1.91	3.57	6.66	12.4	17.9	23.2	28.3	38.4	34.4	
15		2.06	3.84	7.17	13.4	19.3	25.0	30.5	41.3	38.2	
16		2.21	4.12	7.69	14.4	20.7	26.8	32.7	44.3	42.1	
17		2.36	4.40	8.21	15.3	22.1	28.6	34.9	47.3	46.1	
18		2.51	4.68	8.73	16.3	23.5	30.4	37.2	50.3	50.2	
19		2.66	4.96	9.26	17.3	24.9	32.2	39.4	53.3	54.5	
20		2.81	5.24	9.78	18.3	26.3	34.1	41.6	56.3	58.8	50.2
21		2.96	5.53	10.3	19.2	27.7	35.9	43.9	59.4	63.3	54.0
22		3.11	5.81	10.8	20.2	29.1	37.8	46.2	62.5	67.8	57.9
23		3.27	6.10	11.4	21.2	30.6	39.6	48.4	65.6	72.5	61.9
24		3.42	6.38	11.9	22.2	32.0	41.5	50.7	68.6	77.3	66.0
25		3.57	6.67	12.5	23.2	33.5	43.4	53.0	71.7	82.2	70.2
28		4.04	7.54	14.1	26.3	37.8	49.0	59.9	81.1	97.4	83.2
30		4.35	8.12	15.2	28.3	40.7	52.8	64.5	87.3	108	92.2
32		4.67	8.71	16.3	30.3	43.7	56.6	69.2	93.6	117	102
35		5.14	9.59	17.9	33.4	48.1	62.3	76.2	103	129	116
40		5.94	11.1	20.7	38.6	55.6	72.0	88.0	119	149	142

Note: Values in the above table are for simplex chain only. For multiplex chains, please multiply the coefficient of multi-strand. (See "Chain Selection" on P120.)

# DID HI-PWR-S100 (Please refer to P35 for sprocket)

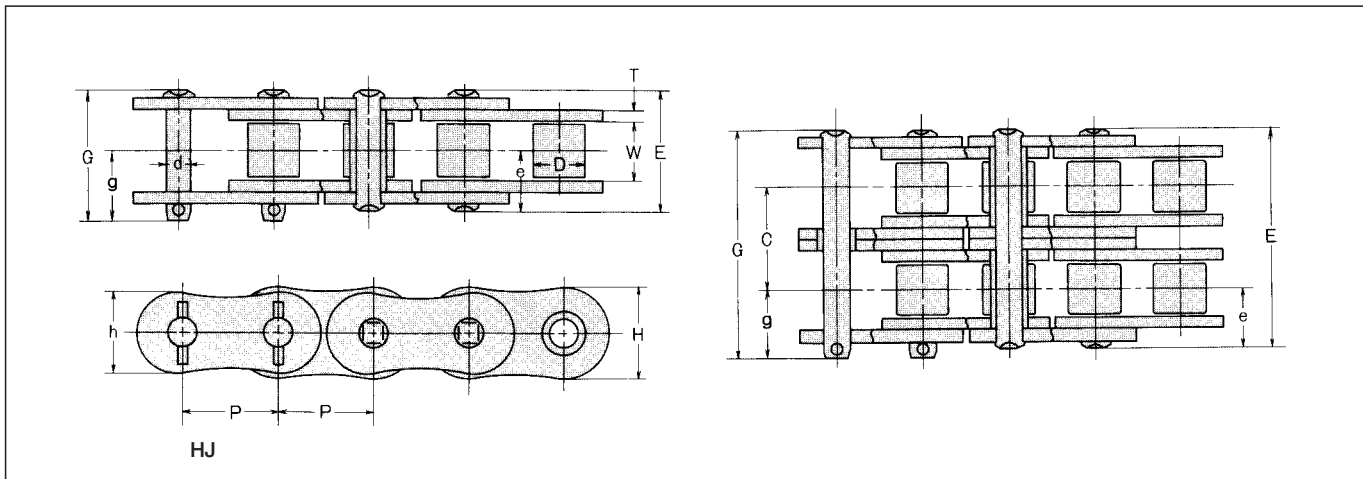

## Dimensions

Chain No.		Pitch P	Roller link width W	Roller dia. D	Pin					Transverse Pitch C	Plate			DID Min. Tensile Strength		DID Avg. Tensile Strength		DID Max. Allowable Load		Approx. Weight (kg/m)	
DID	ANSI*				d	E	G	e	g		T	H	h	kN	kgf	kN	kgf	kN	kgf		
DID HI-PWR-S 100	100					39.5	42.5								116.7	11,900	127	13,000	30.4	3,100	4.18
DID HI-PWR-S 100-2	100-2	31.75	19.05	19.05	9.54	75.3	78.3	19.8	22.7	35.8	4.0	30.1	26.0		233.4	23,800	255	26,000	51.6	5,270	8.21
DID HI-PWR-S 100-3	100-3					111.2	114.2								350.1	35,700	382	39,000	76.0	7,750	12.2

Note: The values of average tensile strength and maximum allowable tension are for chains.

\*Equivalent to ANSI

## Max. kilowatt Ratings HI-PWR-S100

No. of Teeth of Small Sprocket	Type of Lubrication	Small sprocket rpm (Refer to P132 for the details of lubrication A, B and C.)																			
		10	25	50	100	200	300	400	500	600	700	800	900								
		A			B			C													
11		1.05	2.40	4.47	8.34	15.6	22.4	29.1	35.5	41.8	41.8										
12		1.15	2.63	4.91	9.16	17.1	24.6	31.9	39.0	46.0	47.6										
13		1.26	2.87	5.35	9.99	18.7	26.9	34.8	42.5	50.1	53.7										
14		1.36	3.11	5.80	10.8	20.2	29.1	37.7	46.1	54.3	60.0										
15		1.47	3.35	6.25	11.7	21.8	31.3	40.6	49.6	58.5	66.6	54.5									
16		1.57	3.59	6.70	12.5	23.3	33.6	43.5	53.2	62.7	72.1	60.0									
17		1.68	3.83	7.15	13.4	24.9	35.9	46.5	56.8	67.0	76.9	65.7									
18		1.79	4.08	7.61	14.2	26.5	38.2	49.5	60.4	71.2	81.8	71.6									
19		1.90	4.32	8.07	15.1	28.1	40.5	52.4	64.1	75.5	86.7	77.7									
20		2.00	4.57	8.53	15.9	29.7	42.8	55.4	67.7	79.8	91.7	83.9									
21		2.11	4.82	8.99	16.8	31.3	45.1	58.4	71.4	84.1	96.6	90.2									
22		2.22	5.06	9.45	17.6	32.9	47.4	61.4	75.1	88.5	102	96.8									
23		2.33	5.31	9.92	18.5	34.5	49.7	64.4	78.8	92.8	107	103									
24		2.44	5.56	10.4	19.4	36.2	52.1	67.5	82.5	97.2	112	110									
25		2.55	5.81	10.9	20.3	37.8	54.4	70.5	86.2	102	117	117									
28		2.88	6.57	12.3	22.9	42.7	61.5	79.7	97.4	115	132	139									
30		3.10	7.08	13.2	24.7	46.0	66.3	85.9	105	124	142	154									
32		3.33	7.59	14.2	26.4	49.3	71.1	92.0	113	133	152	170	142								
35		3.67	8.36	15.6	29.1	54.3	78.3	101	124	146	168	189	163								
40		4.23	9.66	18.0	33.6	62.8	90.4	117	143	169	194	219	199								

Note: Values in the above table are for simplex chain only. For multiplex chains, please multiply the coefficient of multi-strand. (See "Chain Selection" on P120.)

## DID HI-PWR-S120 (Please refer to P37 for sprocket)

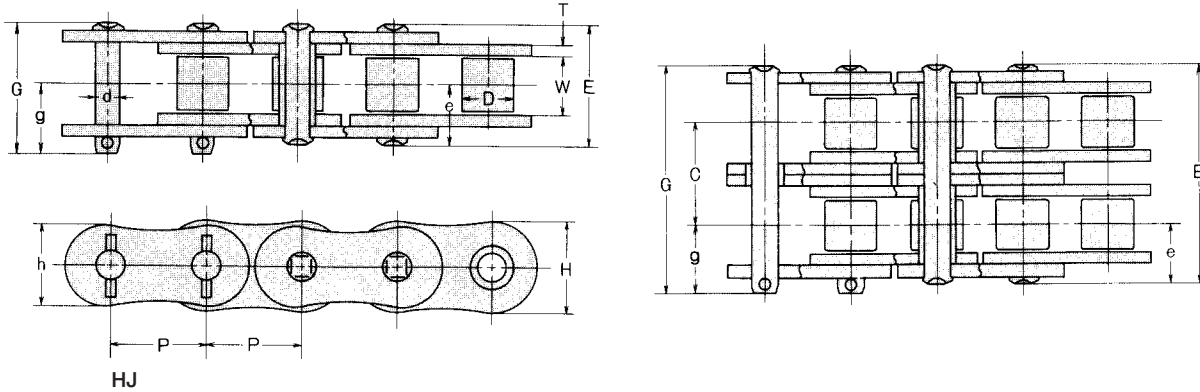

### Dimensions

Unit (mm)

Chain No.	Pitch	Roller link width	Roller dia.	Pin					Transverse Pitch	Plate				DID Min. Tensile Strength		DID Avg. Tensile Strength		DID Max. Allowable Load		Approx. Weight (kg/m)	
				DID	ANSI*	P	W	D		d	E	G	e	g	C	T	H	h	kN		kgf
DID HI-PWR-S 120	120														161.8	16,500	186	19,000	40.2	4,100	6.12
DID HI-PWR-S 120-2	120-2	38.10	25.40	22.23	11.11	49.7	53.0	24.9	28.2	45.4	4.8	36.2	31.2	323.6	33,000	372	38,000	68.3	6,970	12.2	
DID HI-PWR-S 120-3	120-3					140.6	143.9							485.4	49,500	559	57,000	100.0	10,250	18.2	

Note: The values of average tensile strength and maximum allowable tension are for chains.

\*Equivalent to ANSI

### Max. kilowatt Ratings HI-PWR-S120

Unit (kW)

No. of Teeth of Small Sprocket	Small sprocket rpm (Refer to P132 for the details of lubrication A, B and C.)											
	10	25	50	100	150	200	300	400	500	600	700	800
Type of Lubrication	A			B			C					
11	1.88	4.29	8.00	14.9	21.5	27.9	40.1	52.0	63.6	60.9		
12	2.06	4.71	8.79	16.4	23.6	30.6	44.1	57.1	69.8	69.4		
13	2.25	5.14	9.58	17.9	25.8	33.4	48.1	62.3	76.1	78.3		
14	2.44	5.56	10.4	19.4	27.9	36.2	52.1	67.5	82.5	87.5		
15	2.63	5.99	11.2	20.0	30.1	39.0	56.1	72.7	88.8	97.1		
16	2.82	6.43	12.0	22.4	32.2	41.8	60.2	77.9	95.3	107		
17	3.01	6.86	12.8	23.9	34.4	44.6	64.2	83.2	102	117	92.9	
18	3.20	7.30	13.6	25.4	36.6	47.4	68.3	88.5	108	127	101	
19	3.39	7.74	14.4	26.9	38.8	50.3	72.4	93.8	115	135	110	
20	3.58	8.18	15.3	28.5	41.0	53.1	76.5	99.2	121	143	119	
21	3.78	8.62	16.1	30.0	43.2	56.0	80.7	105	128	151	128	
22	3.97	9.06	16.9	31.6	45.5	58.9	84.8	110	134	158	137	
23	4.17	9.51	17.8	33.1	47.7	61.8	89.0	115	141	166	146	
24	4.37	9.96	18.6	34.7	49.9	64.7	93.2	121	148	174	156	
25	4.56	10.4	19.4	36.2	52.2	67.6	97.4	126	154	182	166	
28	5.16	11.8	22.0	41.0	59.0	76.4	110	143	174	205	196	
30	5.55	12.7	23.6	44.1	63.6	82.3	119	154	188	221	218	
32	5.96	13.6	25.4	47.3	68.1	88.3	127	165	201	237	240	
35	6.56	15.0	27.9	52.1	75.1	97.3	140	181	222	261	274	
40	7.58	17.3	32.3	60.2	86.7	112	162	210	256	302	235	274

Note: Values in the above table are for simplex chain only. For multiplex chains, please multiply the coefficient of multi-strand. (See "Chain Selection" on P120.)



# DID HI-PWR-S140 (Please refer to P39 for sprocket)

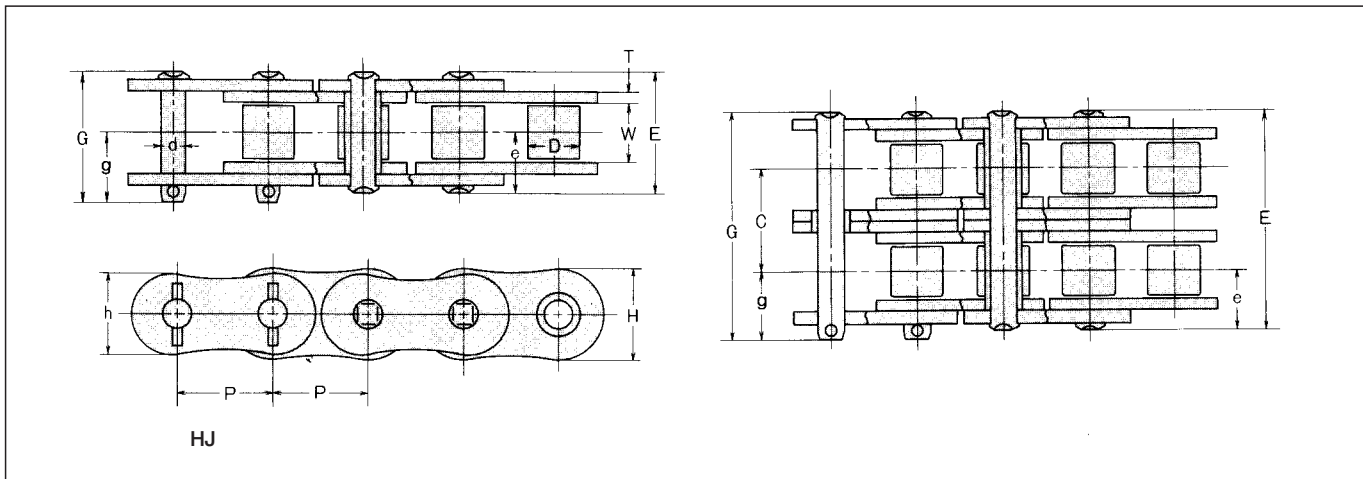

## Dimensions

Chain No.		Pitch P	Roller link width W	Roller dia. D	Pin					Transverse Pitch C	Plate			DID Min. Tensile Strength		DID Avg. Tensile Strength		DID Max. Allowable Load		Approx. Weight (kg/m)	
DID	ANSI*				d	E	G	e	g		T	H	h	kN	kgf	kN	kgf	kN	kgf		
DID HI-PWR-S 140	140					53.6	58.4								215.7	22,000	245	25,000	53.9	5,500	7.71
DID HI-PWR-S 140-2	140-2	44.45	25.40	25.40	12.71	102.6	107.4	26.8	31.7	48.9	5.6	42.2	36.3		431.4	44,000	490	50,000	91.7	9,350	15.3
DID HI-PWR-S 140-3	140-3					151.5	156.3								647.1	66,000	735	75,000	134.0	13,750	22.9

Note: The values of average tensile strength and maximum allowable tension are for chains.

\*Equivalent to ANSI

## Max. kilowatt Ratings HI-PWR-S140

No. of Teeth of Small Sprocket	Type of Lubrication	Small sprocket rpm (Refer to P132 for the details of lubrication A, B and C.)													
		10	25	50	100	150	200	250	300	350	400	450	500	550	600
		A			B			C							
11		2.89	6.60	12.3	23.0	33.1	42.9	52.4	61.8	70.9	80.0	89.0	90.6	78.6	68.9
12		3.18	7.25	13.5	25.2	36.4	47.1	57.6	67.8	77.9	87.9	97.7	103	89.5	78.6
13		3.46	7.90	14.8	27.5	39.6	51.4	62.8	74.0	85.0	95.8	107	116	101	88.6
14		3.75	8.56	16.0	29.8	42.9	55.6	68.0	80.1	92.1	104	115	127	112	99.0
15		4.04	9.22	17.2	32.1	46.3	59.9	73.3	86.3	99.2	112	124	137	125	110
16		4.33	9.89	18.5	34.4	49.6	64.3	78.6	92.6	106	120	133	147	138	121
17		4.63	10.6	19.7	36.8	53.0	68.6	83.9	98.8	114	128	142	156	151	132
18		4.92	11.2	21.0	39.1	56.3	73.0	89.2	105	121	136	151	166	164	144
19		5.22	11.9	22.2	41.5	59.7	77.4	94.6	111	128	144	161	176	178	157
20		5.52	12.6	23.5	43.8	63.1	81.8	100	118	135	153	170	187	193	169
21		5.81	13.3	24.8	46.2	66.5	86.2	105	124	143	161	179	197	207	182
22		6.11	14.0	26.0	48.6	70.0	90.6	111	131	150	169	188	207	222	195
23		6.42	14.6	27.3	51.0	73.4	95.1	116	137	157	177	197	217	236	208
24		6.72	15.3	28.6	53.4	76.9	99.6	122	143	165	186	207	227	247	222
25		7.02	16.0	29.9	55.8	80.3	104	127	150	172	194	216	237	259	236
28		7.93	18.1	33.8	63.0	90.8	118	144	169	195	219	244	268	292	280
30		8.55	19.5	36.4	67.9	97.8	127	155	182	210	236	263	289	315	311
32		9.16	20.9	39.0	72.8	105	136	166	196	225	253	282	310	338	342
35		10.1	23.0	43.0	80.2	116	150	183	216	248	279	310	341	372	391
40		11.7	26.6	49.6	92.6	133	173	211	249	286	323	359	394	430	

Note: Values in the above table are for simplex chain only. For multiplex chains, please multiply the coefficient of multi-strand. (See "Chain Selection" on P120.)

## DID HI-PWR-S160 (Please refer to P41 for sprocket)

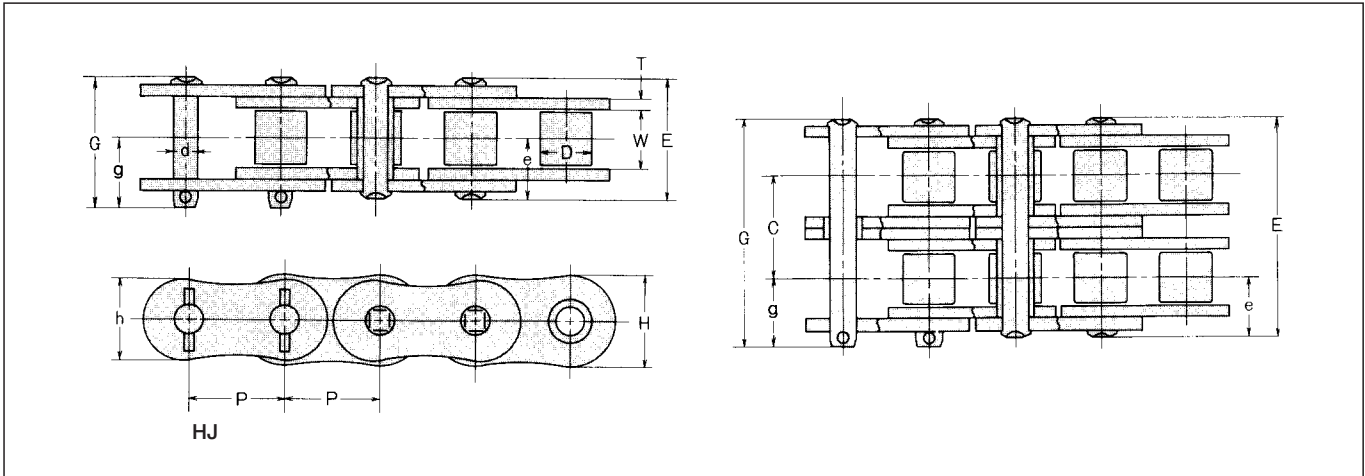

### Dimensions

Unit (mm)

Chain No.	Pitch	Roller link width	Roller dia.	Pin					Transverse Pitch	Plate				DID Min. Tensile Strength		DID Avg. Tensile Strength		DID Max. Allowable Load		Approx. Weight (kg/m)	
				D	d	E	G	e		g	C	T	H	h	kN	kgf	kN	kgf	kN		kgf
DID HI-PWR-S 160	160					63.6	68.2								272.6	27,800	313	32,000	70.6	7,200	10.5
DID HI-PWR-S 160-2	160.2	50.80	31.75	28.58	14.29	122.2	126.8	31.9	36.5	58.5	6.4	48.2	41.4		545.2	55,600	627	64,000	120	12,240	20.8
DID HI-PWR-S 160-3	160.3					180.8	185.4								817.8	83,400	941	96,000	176	18,000	31.2

Note: The values of average tensile strength and maximum allowable tension are for chains.  
\*Equivalent to ANSI

### Max. kilowatt Ratings HI-PWR-S160

Unit (kW)

No. of Teeth of Small Sprocket	Type of Lubrication	Small sprocket rpm (Refer to P132 for the details of lubrication A, B and C.)												
		10	25	50	100	150	200	250	300	350	400	450	500	550
		<b>A</b>	<b>B</b>			<b>C</b>								
11		4.03	9.19	17.1	32.0	46.1	59.7	73.0	86.0	98.8	111	118	101	
12		4.42	10.1	18.8	35.1	50.6	65.6	80.2	94.5	109	122	135	115	
13		4.82	11.0	20.5	38.3	55.2	71.5	87.4	103	118	133	148	130	
14		5.23	11.9	22.2	41.5	59.8	77.5	94.7	112	128	145	161	145	
15		5.63	12.8	24.0	44.7	64.4	83.4	102	120	138	156	173	161	
16		6.04	13.8	25.7	47.9	69.1	89.5	109	129	148	167	186	177	
17		6.44	14.7	27.4	51.2	73.7	95.5	117	138	158	178	198	194	
18		6.85	15.6	29.2	54.5	78.4	102	124	146	168	190	211	211	
19		7.27	16.6	30.9	57.7	83.1	108	132	155	178	201	223	229	198
20		7.68	17.5	32.7	61.0	87.9	114	139	164	188	212	236	247	214
21		8.10	18.5	34.5	64.3	92.6	120	147	173	199	224	249	266	231
22		8.51	19.4	36.2	67.6	97.4	126	154	182	200	235	262	285	247
23		8.93	20.4	38.0	71.0	102	132	162	191	219	247	275	302	264
24		9.35	21.3	39.8	74.3	107	139	169	200	229	259	288	316	282
25		9.77	22.3	41.6	77.6	112	145	177	209	240	270	301	330	299
28		11.1	25.2	47.0	87.7	126	164	200	236	271	306	340	373	355
30		11.9	27.2	50.7	94.5	136	176	216	254	292	329	366	402	394
32		12.8	29.1	54.3	101	146	189	231	272	313	353	392	431	434
35		14.1	32.1	59.8	112	161	208	255	300	345	389	432	475	496
40		16.2	37.0	69.1	129	186	241	294	347	398	449	499	549	598

Note: Values in the above table are for simplex chain only. For multiplex chains, please multiply the coefficient of multi-strand. (See "Chain Selection" on P120.)

# DID HI-PWR-S180 (Please refer to P43 for sprocket)

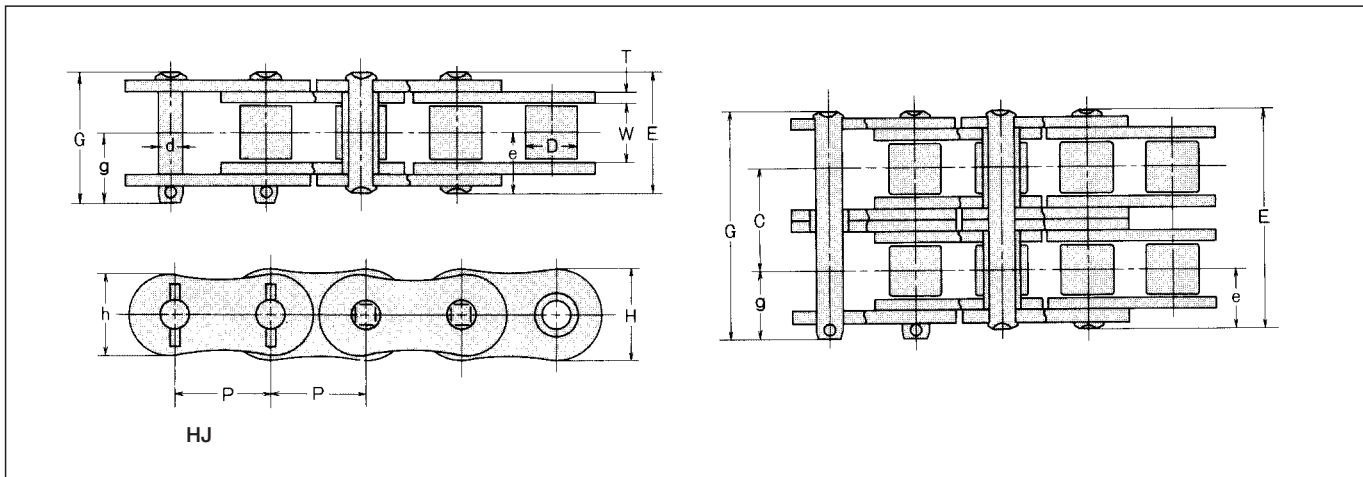

## Dimensions

Chain No.		Pitch P	Roller link width W	Roller dia. D	Pin					Transverse Pitch C	Plate			DID Min. Tensile Strength		DID Avg. Tensile Strength		DID Max. Allowable Load		Approx. Weight (kg/m)	
DID	ANSI*				d	E	G	e	g		T	H	h	kN	kgf	kN	kgf	kN	kgf		
DID HI-PWR-S 180	180					71.5	77.3								378.3	38,600	412	42,000	83.3	8,500	14.4
DID HI-PWR-S 180-2	180-2	57.15	35.72	35.71	17.46	137.4	143.2	35.8	41.6	65.8	7.1	54.2	46.6		756.6	77,200	824	84,000	141	14,450	28.6
DID HI-PWR-S 180-3	180-3					203.3	209.1								1,134.0	115,800	1,236	126,000	208	21,250	42.7

Note: The values of average tensile strength and maximum allowable tension are for chains.

\*Equivalent to ANSI

## Max. kilowatt Ratings HI-PWR-S180

No. of Teeth of Small Sprocket	Type of Lubrication	Small sprocket rpm (Refer to P132 for the details of lubrication A, B and C.)									
		10	25	50	100	150	200	250	300	350	400
		<b>A</b>	<b>B</b>			<b>C</b>					
11		5.24	12.0	22.3	41.6	60.0	77.7	95.0	112	129	
12		5.76	13.1	24.5	45.7	65.9	85.4	104	123	141	
13		6.28	14.3	26.7	49.9	71.8	93.1	114	134	154	
14		6.80	15.5	29.0	54.0	77.8	101	123	145	167	
15		7.33	16.7	31.2	58.2	83.8	109	133	156	180	
16		7.86	17.9	33.4	62.4	89.9	116	142	168	193	
17		8.39	19.1	35.7	66.6	96.0	124	152	179	206	
18		8.92	20.4	38.0	70.9	102	132	162	191	219	
19		9.46	21.6	40.3	75.1	108	140	171	202	232	
20		10.0	22.8	42.6	79.4	114	148	181	213	245	277
21		10.5	24.0	44.9	83.7	121	156	191	225	259	292
22		11.1	25.3	47.2	88.0	127	164	201	237	272	307
23		11.6	26.5	49.5	92.4	133	172	211	248	285	322
24		12.2	27.8	51.8	96.7	139	180	221	260	299	337
25		12.7	29.0	54.2	101	146	189	231	272	312	352
28		14.4	32.8	61.2	114	165	213	261	307	353	398
30		15.5	35.3	65.9	123	177	230	281	331	380	429
32		16.6	37.9	70.7	132	190	246	301	355	407	459
35		18.3	41.7	77.9	145	209	271	332	391	449	506
40		21.1	48.2	90.0	168	242	313	383	451	518	585

Note: Values in the above table are for simplex chain only. For multiplex chains, please multiply the coefficient of multi-strand. (See "Chain Selection" on P120.)

## DID HI-PWR-S200 (Please refer to P45 for sprocket)

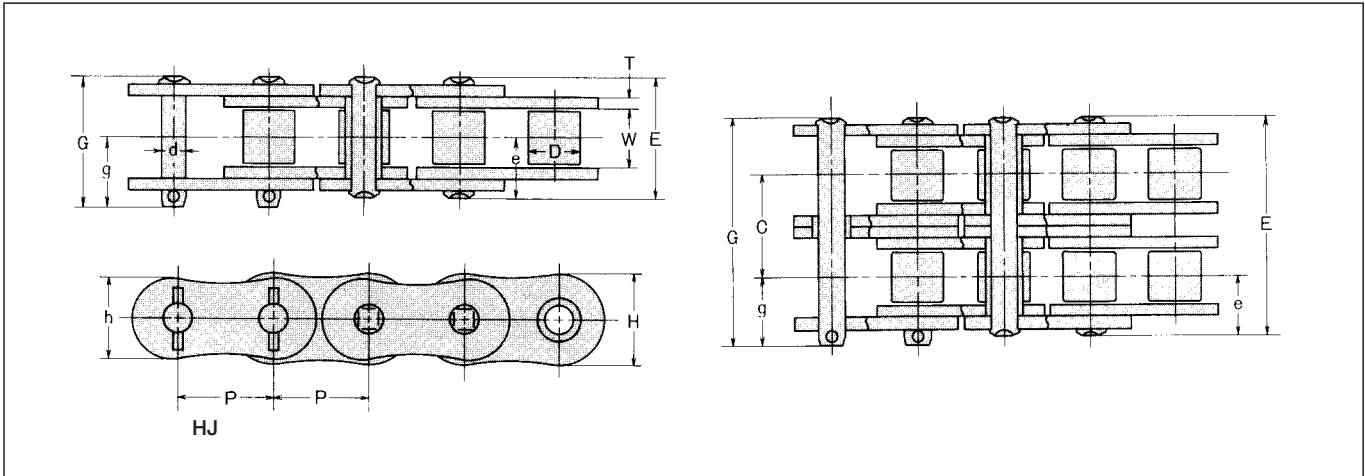

### Dimensions

Unit (mm)

Chain No.	Pitch	Roller link width W	Roller dia. D	Pin					Transverse Pitch C	Plate				DID Min. Tensile Strength		DID Avg. Tensile Strength		DID Max. Allowable Load		Approx. Weight (kg/m)
				d	E	G	e	g		T	H	h	kN	kgf	kN	kgf	kN	kgf		
DID HI-PWR-S 200	200				77.9	85.0								459.9	46,900	500	51,000	98.1	10,000	17.5
DID HI-PWR-S 200-2	200.2	63.50	38.10	39.68	19.85	149.6	156.6	39.0	46.0	71.6	8.0	60.2	52.0	919.8	93,800	1,000	102,000	166	17,000	34.7
DID HI-PWR-S 200-3	200.3					221.3	228.3							1,379	140,700	1,500	153,000	245	25,000	52.0

Note: The values of average tensile strength and maximum allowable tension are for chains.  
\*Equivalent to ANSI

### Max. kilowatt Ratings HI-PWR-S200

Unit (kW)

No. of Teeth of Small Sprocket	Small sprocket rpm (Refer to P132 for the details of lubrication A, B and C.)											
	10	15	20	30	40	50	60	80	100	150	200	250
	A			B						C		
11	6.95	10.0	13.0	18.7	24.2	29.6	34.8	45.1	55.2	79.5	103	126
12	7.63	11.0	14.2	20.5	26.6	32.5	38.3	49.6	60.6	87.3	113	138
13	8.32	12.0	15.5	22.4	29.0	35.4	41.7	54.1	66.1	95.2	123	151
14	9.01	13.0	16.8	24.2	31.4	38.4	45.2	58.6	71.6	103	134	163
15	9.71	14.0	18.1	26.1	33.8	41.3	48.7	63.1	77.1	111	144	176
16	10.4	15.0	19.4	28.0	36.3	44.3	52.2	67.7	82.7	119	154	189
17	11.1	16.0	20.7	29.9	38.7	47.3	55.8	72.2	88.3	127	165	201
18	11.8	17.0	22.1	31.8	41.2	50.3	59.3	76.8	93.9	135	175	214
19	12.5	18.1	23.4	33.7	43.7	53.6	62.9	81.4	99.6	143	186	227
20	13.3	19.1	24.7	35.6	46.1	56.4	66.5	86.1	105	152	196	240
21	14.0	20.1	26.1	37.5	46.8	59.4	70.0	90.7	111	160	207	253
22	14.7	21.2	27.4	39.5	51.1	62.5	73.7	95.4	117	168	218	266
23	15.4	22.2	28.8	41.4	53.7	65.6	77.3	100	122	176	228	279
24	16.1	23.2	30.1	43.4	56.2	68.7	80.9	105	128	185	239	292
25	16.9	24.3	31.5	45.3	58.7	71.8	84.6	110	134	193	250	
28	19.1	27.4	35.6	51.2	66.4	81.1	95.6	124	151	218	282	
30	20.5	29.6	38.3	55.2	71.5	87.4	103	133	163	235	304	
32	22.0	31.7	41.1	59.2	76.6	93.7	110	143	175	252	326	
35	24.2	34.9	45.2	65.2	84.4	103	122	158	193	277	359	
40	28.0	40.3	52.3	75.3	97.5	119	140	182	222	320	415	

Note: Values in the above table are for simplex chain only. For multiplex chains, please multiply the coefficient of multi-strand. (See "Chain Selection" on P120.)

# DID HI-PWR-S240 (Please refer to P47 for sprocket)

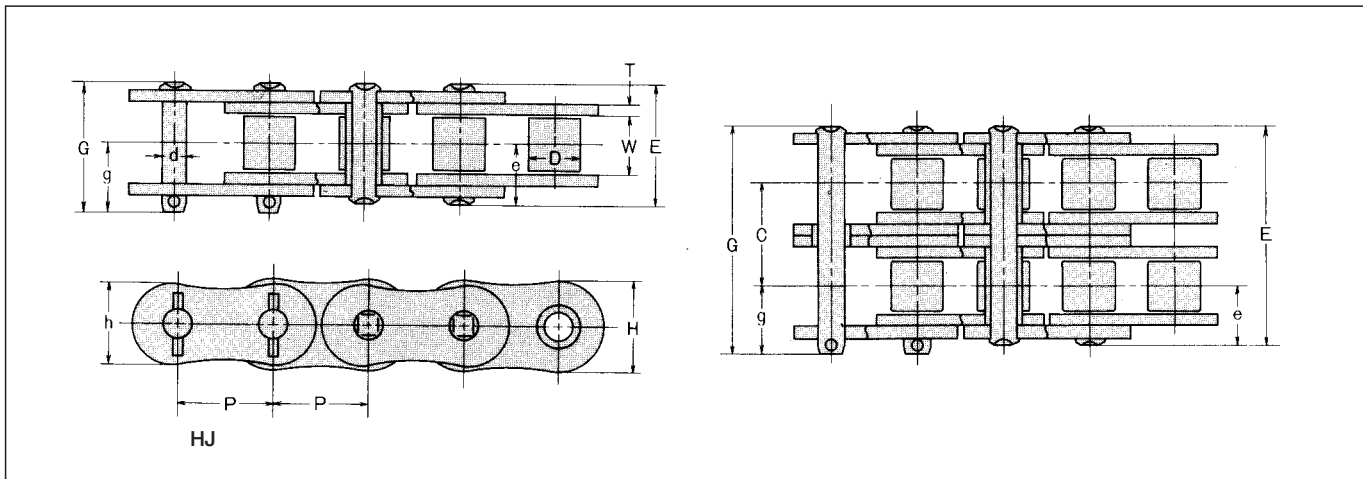

## Dimensions

Chain No.		Pitch P	Roller link width W	Roller dia. D	Pin					Transverse Pitch C	Plate				DID Min. Tensile Strength		DID Avg. Tensile Strength		DID Max. Allowable Load		Approx. Weight (kg/m)
DID	ANSI*				d	E	G	e	g		T	H	h	kN	kgf	kN	kgf	kN	kgf		
DID HI-PWR-S 240	240				95.2	102.9									666.8	68,000	725	74,000	132	13,500	24.7
DID HI-PWR-S 240-2	240-2	76.20	47.63	47.63	23.81	183.1	190.8	47.7	55.3	87.8	9.50	72.2	62.0		1,333	136,000	1,451	148,000	225	22,950	49.0
DID HI-PWR-S 240-3	240-3					270.9	278.6								2,000	204,000	2,177	222,000	331	33,750	73.3

Note: The values of average tensile strength and maximum allowable tension are for chains.

\*Equivalent to ANSI

## Max. kilowatt Ratings HI-PWR-S240

No. of Teeth of Small Sprocket	Type of Lubrication	Small sprocket rpm (Refer to P132 for the details of lubrication A, B and C.)												
		5	10	15	20	25	30	40	50	60	80	100	125	150
		A			B						C			
11		5.95	11.1	16.0	20.7	25.3	29.8	38.6	47.2	55.7	72.1	88.1	108	127
12		6.53	12.2	17.6	22.8	27.8	32.8	42.5	51.9	61.1	79.2	96.8	118	139
13		7.12	13.3	19.1	24.8	30.3	35.7	46.3	56.6	66.7	86.4	106	129	152
14		7.72	14.4	20.7	26.9	32.8	38.7	50.1	61.3	72.2	93.6	114	140	165
15		8.31	15.5	22.3	29.0	35.4	41.7	54.0	66.0	77.8	101	123	151	177
16		8.91	16.6	24.0	31.0	37.9	44.7	57.9	70.8	83.4	108	132	161	190
17		9.52	17.8	25.6	33.1	40.5	47.7	61.8	75.6	89.1	115	141	172	203
18		10.1	18.9	27.2	35.3	43.1	50.8	65.8	80.4	94.7	123	150	183	216
19		10.7	20.0	28.8	37.4	45.7	53.8	69.7	85.2	100	130	159	194	229
20		11.3	21.2	30.5	39.5	48.3	56.9	73.7	90.1	106	138	168	206	242
21		12.0	22.3	32.1	41.6	50.9	60.0	77.7	95.0	112	145	177	217	255
22		12.6	23.5	33.8	43.8	53.5	63.1	81.7	99.9	118	152	186	228	
23		13.2	24.6	35.5	45.9	56.1	66.2	85.7	105	123	160	196	239	
24		13.8	25.8	37.1	48.1	58.8	69.3	89.7	110	129	167	205	250	
25		14.4	26.9	38.8	50.3	61.4	72.4	93.8	115	135	175	214	262	
28		16.3	30.4	43.8	56.8	69.4	81.8	106	130	153	198	242	296	
30		17.6	32.8	47.2	61.2	74.8	88.1	114	140	164	213	260	318	
32		18.8	35.2	50.6	65.6	80.2	94.5	122	150	176	228	279	341	
35		20.8	38.7	55.8	72.3	88.4	104	135	165	194	252	308		
40		24.0	44.7	64.4	83.5	102	120	156	190	224	291	355		

Note: Values in the above table are for simplex chain only. For multiplex chains, please multiply the coefficient of multi-strand. (See "Chain Selection" on P120.)

## HK Type Roller Chains



### Downsizing Your System with Higher Power Chains

HK type roller chains conform to H type of ANSI, and their thickness of inner and outer link plates are equal to those of the next larger size chain. Therefore, HK type roller chains are higher in tensile strength by about 20% and in maximum allowable load by about 15% than those of standard roller chains. Since the weight of the chains is also larger, HK type roller chains are suitable for the application of heavy duty at low speed.

#### Recommended uses

- Optimal for places where higher strength is required but large and heavier chains cannot be used.

#### <Examples>

Asphalt finishers

#### HK Type Connecting Link and Offset Link

	Connecting link		Offset link	
	Clearance fit	Interference fit	Clearance fit	2-Pitch Offset link (Interference fit)
Applicable connecting link	RJ: DID 50 & under CJ: DID 80 & over RJ/ CJ: DID 60	FJ: DID 50 & under HJ: DID 80 & over FJ/ HJ: DID 60	OJ: exclusive use for HK (unavailable for DID 40HK & under)	2POJ: exclusive use for HK (unavailable for DID 40HK & under)
Tensile Strength	Same as chain			

#### Selection of chains

Select a proper HK type roller chain based on "Low-speed selection" (P121). For the maximum allowable load, see the following table of dimensions.

HK type roller chains are available up to triplex.

#### Sprockets

Use standard sprockets for a simplex HK roller chain. Since the transverse pitches (C dimension: see P61) are larger than those of standard chains in the case of duplex or triplex, standard sprockets cannot be used. Refer to the sprocket tooth profiles for HK (see P116~117).

#### Connecting link and offset link

The tensile strength of connecting links and offset links are listed on the left, but the maximum allowable load is lower than that of the base chain. Please consult us should you have any questions. It is recommended to use the connecting link of interference-fitted (FJ, HJ).

Never make the holes of the connecting plate larger and never make the pins thinner to facilitate the work for fitting the pins into the connecting plate, since otherwise the fatigue strength will be lowered.



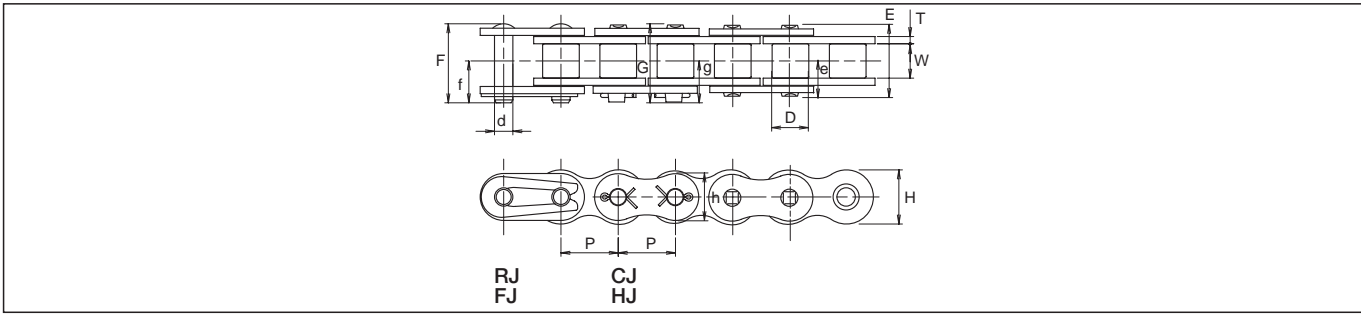

**Dimensions**

Unit (mm)

Chain No.	Pitch P	Roller link width W	Roller dia. D	Pin						Plate			Min. tensile strength		Avg. tensile strength		Max. allowable load		Approx. weight (kg/m)
				d	E	F	G	f	g	T	H	h	kN	kgf	kN	kgf	kN	kgf	
<b>DID 40HK</b>	12.70	7.95	7.92	3.97	18.5	19.5	—	10.5	—	2.0	12.0	10.4	19.6	2,000	21.5	2,000	4.51	460	0.72
<b>DID 50HK</b>	15.875	9.53	10.16	5.09	21.8	23.4	—	12.6	—	2.4	15.0	13.0	33.34	3,400	36.3	3,700	8.63	880	1.12
<b>DID 60HK</b>	19.05	12.70	11.91	5.96	28.7	30.5	31.2	16.1	16.9	3.2	18.1	15.6	47.07	4,800	52.0	5,300	10.70	1,100	1.81

- Note: 1. The values of average tensile strength and maximum allowable tension are for chains.  
 2. When grooving using sprockets with smaller number of teeth, the grooves may interfere with the chain outer plate. Consult us for advise.  
 3. Ask us for the delivery time.

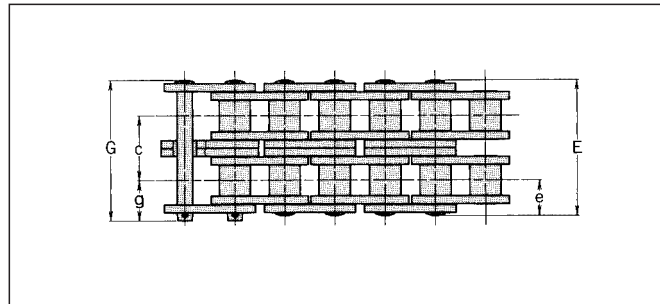
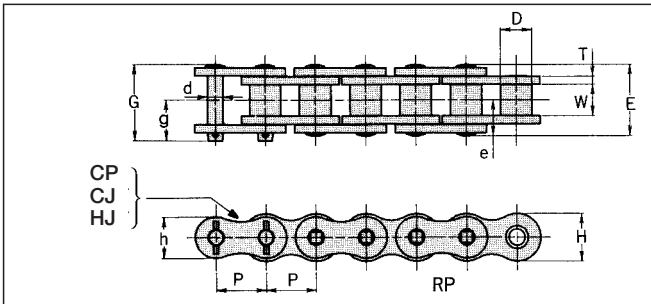

**Dimensions**

Unit (mm)

Chain No.	Pitch P	Roller link width W	Roller dia. D	Pin					Transverse Pitch C	Plate			Min. tensile strength		Avg. tensile strength		Max. allowable load		Approx. weight (kg/m)
				d	E	G	e	g		T	H	h	kN	kgf	kN	kgf	kN	kgf	
<b>DID 80HK</b>	25.4	15.88	15.88	7.94	36.1	38.7	18.1	20.6	32.6	4.0	24.0	20.8	81.3	8,300	96.1	9,800	16.6	1,700	2.97
<b>DID 80HK-2</b>					68.5	71.3							162	16,600	192	19,600	28.3	2,890	5.88
<b>DID 80HK-3</b>					101.2	104.0							244	24,900	288	29,400	41.6	4,250	8.76
<b>DID 100HK</b>	31.75	19.05	19.05	9.54	43.6	45.8	21.8	24.4	39.1	4.8	29.9	26.0	123	12,600	142	14,500	26.4	2,700	4.16
<b>DID 100HK-2</b>					82.0	85.1							246	25,200	284	29,000	45.0	4,590	8.23
<b>DID 100HK-3</b>					121.1	124.1							369	37,800	426	43,500	66.1	6,750	12.27
<b>DID 120HK</b>	38.10	25.40	22.23	11.11	54.1	56.5	27.1	29.9	48.9	5.6	35.9	31.2	166	17,000	191	19,500	34.3	3,500	6.08
<b>DID 120HK-2</b>					102.2	105.5							332	34,000	426	39,000	58.3	5,950	12.04
<b>DID 120HK-3</b>					151.1	154.4							498	51,000	573	58,500	85.8	8,750	17.94
<b>DID 140HK</b>	44.45	25.40	25.40	12.71	57.9	61.7	29.0	33.3	52.2	6.4	41.9	36.3	217	22,200	250	25,500	45.1	4,600	8.81
<b>DID 140HK-2</b>					109.2	114.0							434	44,400	500	51,000	76.6	7,820	17.44
<b>DID 140HK-3</b>					161.4	166.2							651	66,600	750	76,500	112.7	11,500	25.99
<b>DID 160HK</b>	50.80	31.75	28.58	14.29	68.0	71.6	34.0	38.2	61.9	7.1	47.8	41.4	277	28,300	318	32,500	58.8	6,000	10.93
<b>DID 160HK-2</b>					133.9	135.1							554	56,600	637	65,000	100	10,200	21.64
<b>DID 160HK-3</b>					195.6	197.1							831	84,900	956	97,500	147	15,000	32.24
<b>DID 180HK</b>	57.15	35.72	35.71	17.46	75.5	80.8	37.8	43.3	69.2	8.0	53.8	46.6	402	41,000	441	45,000	71.5	7,300	14.81
<b>DID 180HK-2</b>					150.0	152.0							804	82,000	882	90,000	121	12,410	29.32
<b>DID 180HK-3</b>					219.3	221.3							1,200	123,000	1,320	135,000	178	18,250	43.69
<b>DID 200HK</b>	63.50	38.10	39.68	19.85	84.4	91.7	42.2	49.4	78.3	9.5	60.0	52.0	486	49,600	558	57,000	83.3	8,500	19.17
<b>DID 200HK-2</b>					170.0	172.3							972	99,200	1,110	114,000	141	14,450	37.95
<b>DID 200HK-3</b>					248.4	250.7							1,450	148,800	1,670	171,000	208	21,250	56.55
<b>DID 240HK</b>	76.20	47.63	47.63	23.81	108.0	116.3	54.0	61.9	101.2	12.7	71.5	62.0	767	78,300	882	90,000	112	11,500	28.30
<b>DID 240HK-2</b>					217.6	220.1							1,530	156,600	1,760	180,000	191	19,550	56.03
<b>DID 240HK-3</b>					318.8	321.3							2,300	234,900	2,640	270,000	281	28,750	83.48

- Note: 1. The above chains are of riveted pin type (RP). As for cotter pin type (CP), consult us.  
 2. The values of average tensile strength and maximum allowable tension are for chains.  
 3. When grooving using sprockets with smaller number of teeth, the grooves may interfere with the chain outer plate. Consult us.

## HI-PWR-SHK Type Roller Chains



### High-end type of the high strength series

The DID HI-PWR-SHK roller chains have thicker link plates than HI-PWR-S roller chains, and are the highest in tensile strength and allowable load among general application chains, thus being suitable for low speed heavy duty transmission.

#### Recommended uses

- The HI-PWR-SHK roller chains are 25 percent higher in tensile strength and 50 percent higher in maximum allowable load than the standard roller chains, but since their weight is heavier, driving performance declines at high speed. So, they are suitable for heavy duty at low speed applications.

#### <Examples>

Multilevel parking machines, pipe benders, construction machines, etc.

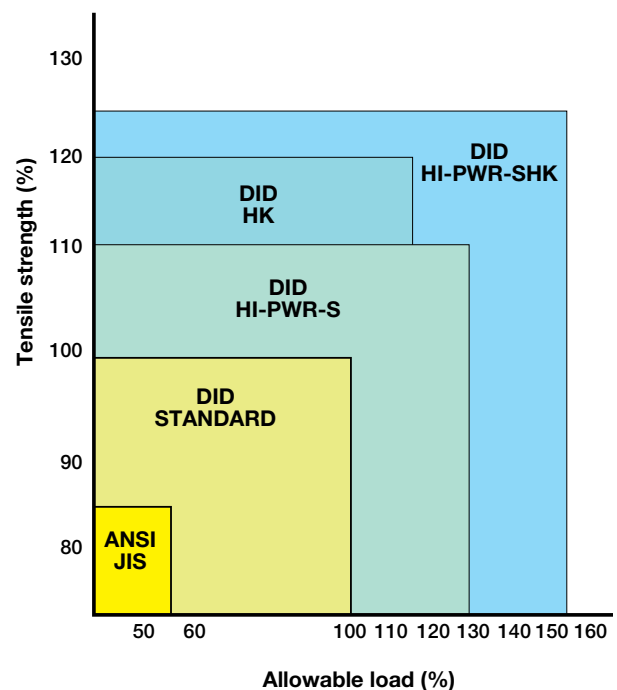

## Selection of chains

Select a proper HI-PWR-SHK type chain based on "Low-speed selection" (P121)

For the maximum allowable load, see the following table of dimensions.

HI-PWR-SHK series is available in simplex.

## Sprockets

Standard sprockets for multiplex chains cannot be used.

## Connecting links and offset links

The best feature of the HI-PWR-SHK roller chains is high maximum allowable load. Therefore, interference-fitted connecting links (H connecting links) with little strength degradation are used.

The connecting plate and the connecting pins are connected with spring pins. The tensile strength of an H connecting link is equivalent to that of the chain, but the allowable load is somewhat lower than that of the chain.

HI-PWR-S type roller chains do not have any offset link. Use an even number of links.

Never make the holes of the connecting plate larger and never make the pins thinner to facilitate the work for fitting the pins into the connecting plate, since otherwise the fatigue strength will be lowered.

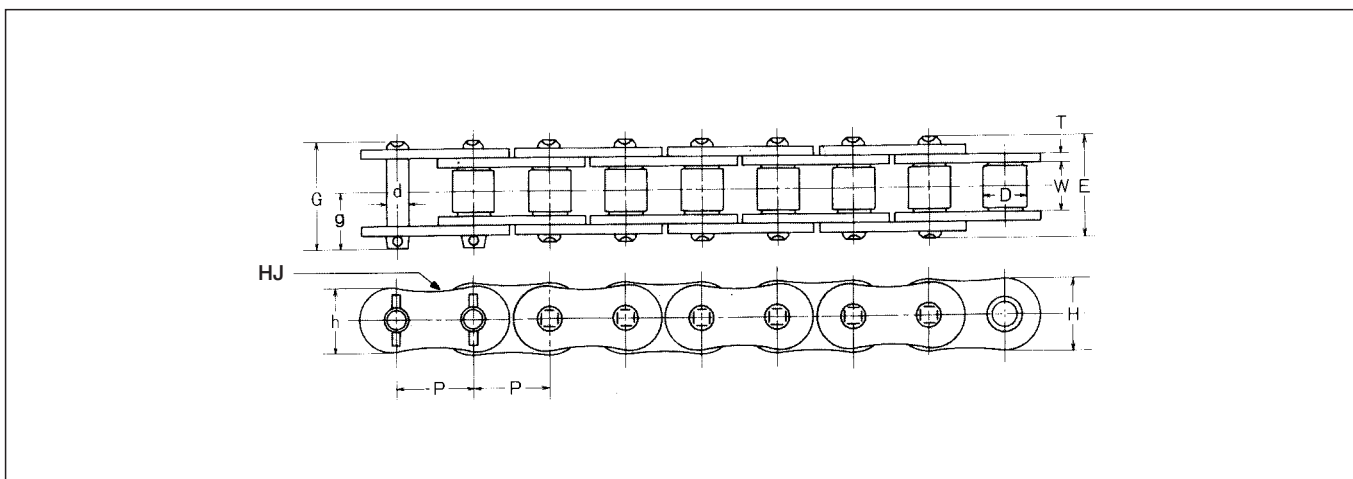

## Dimensions



Unit (mm)

Chain No.	Pitch		Roller link width	Roller dia.	Pin				Plate			Min. tensile strength		Avg. tensile strength		Max. allowable load		Approx. weight (kg/m)
	P	W			d	E	G	g	T	H	h	kN	kgf	kN	kgf	kN	kgf	
<b>DID HI-PWR-S 80HK</b>	25.40	15.88	15.88	7.94	36.1	38.7	20.6	4.0	24.1	20.8	85.3	8,700	98.1	10,000	22.5	2,300	3.12	
<b>DID HI-PWR-S 100HK</b>	31.75	19.05	19.05	9.54	43.6	46.2	24.4	4.8	30.1	26.0	126	12,900	145	14,800	34.3	3,500	4.37	
<b>DID HI-PWR-S 120HK</b>	38.10	25.40	22.23	11.11	54.1	57.0	29.9	5.6	36.2	31.2	170	17,400	196	20,000	45.1	4,600	6.39	
<b>DID HI-PWR-S 140HK</b>	44.45	25.40	25.40	12.71	57.9	62.1	33.3	6.4	42.4	36.3	221	22,600	255	26,000	60.8	6,200	9.25	
<b>DID HI-PWR-S 160HK</b>	50.80	31.75	28.58	14.29	68.0	72.2	38.2	7.1	48.2	41.4	281	28,700	323	33,000	77.4	7,900	11.48	
<b>DID HI-PWR-S 180HK</b>	57.15	35.72	35.71	17.46	75.5	81.0	43.3	8.0	54.2	46.6	421	43,000	461	47,000	91.2	9,300	15.55	
<b>DID HI-PWR-S 200HK</b>	63.50	38.10	39.68	19.85	84.4	91.3	49.4	9.5	60.2	52.0	519	53,000	598	61,000	112	11,500	20.13	
<b>DID HI-PWR-S 240HK</b>	76.20	47.63	47.63	23.81	108.0	115.6	61.7	12.7	72.2	62.0	802	81,800	922	94,000	155	15,900	29.72	

Note: 1. The values of average tensile strength and maximum allowable tension are for chains.

2. When grooving using sprockets with smaller number of teeth, the grooves may interfere with the chain outer plate. Consult us.

## Dependable in severe conditions

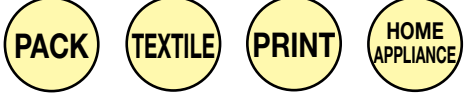
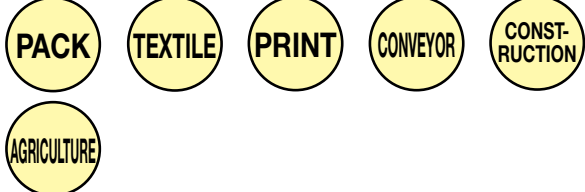
Name	Solid Bushing Chain (HT/ T), (D)	DH- $\alpha$ Chain (DHA)
Features	<ul style="list-style-type: none"> <li>① Incorporating high precision solid bushing.</li> <li>② Ideally suited when increased wear resistance is required.</li> <li>③ Up to <math>\zeta</math>S times longer wear life than standard chain.</li> </ul>	<ul style="list-style-type: none"> <li>① Forming extremely hardened carbide layer on pin surface.</li> <li>② Suitable for bad atmosphere such as deterioration of lubrication and invasion of contaminant particles between pin and bushing.</li> <li>③ Up to <math>\zeta</math>V times longer wear life than standard chain.</li> </ul>
Functions		
Main uses		

■ Table of Ultimate Life Chain Series

Chain No.	Long Life	DH- $\alpha$	O-Ring	Sintered Bushing
DID 25	HT	DHA	-	-
DID 35	T	DHA	LD	-
DID 41	-	DHA	-	-
DID 40	D	DHA	LX	UR, URN
DID 50	D	DHA	LX	UR, URN
DID 60	D	DHA	LX	UR, URN
DID 80	D	-	LD	UR, URN
DID 100	D	-	LD	-
DID 120	-	-	LD	-
DID 140	-	-	LD	-
DID 160	-	-	LD	-
DID 200	-	-	LD	-
DID 240	-	-	LD	-

■ Chain dimensions

Dimensions for Roller Chains for Transmission are shown on the pages of their descriptions and dimensions for Small Chains for Conveyor System are on P148-P155.

O-Ring Chain/X-Ring Chain (LD/ LX)	Sintered Bushing Roller Chain (UR), (URN)	Name
<p>① DID X-Ring chain is the best value of maintenance-free chain available.</p> <p>② The patented X-Ring design has half the friction of normal O-Ring chain and provides great sealing performance. It keeps the dirt out and the grease in much better than any other O-rings.</p> <p>③ Up to 2 times longer wear resistance performance compared to normal O-Ring chains.</p> <p>④ Great cost savings can be achieved through longer life and less down time.</p>	<p>① Sintered bushing is incorporated.</p> <p>② Ultimate Life Chain for low speed and light load applications.</p> <p>③ Up to 2 times longer wear life than standard chain.</p>	Features
		Functions
		Main uses

※ LX: Temp. -10°C~120°C, LD: Temp. -10°C~80°C

## Symbols

Functions	Resistant against contaminated or deteriorated oil Resistant against dusty circumstances	No lubrication or maintenance Tension strength index (Compared to standard roller chains)	Allowable ambient temperature
Main uses	Feed and drive in food processing machines Feed and drive in printing machines Feed and drive in construction machines	Feed and drive in packaging machines Feed and drive in the conveyors and transfer equipment Feed and drive of home appliances	Feed and drive in textile machines Feed and drive in can conveyors and for painting and drying cans Drive of agricultural machines

Wide range of product line-up

**O-Ring Chain and Sintered Bushing Roller Chain applicable for use under various conditions**

Two types of maintenance-free chains

The Ultimate Life Chain Series includes two types of maintenance-free chains, O-Ring Chain and Sintered Bushing Roller Chain. They can be applied in various conditions from low-speed to high-speed operation, or from low-load to high-load operation as you can see in the chart below.

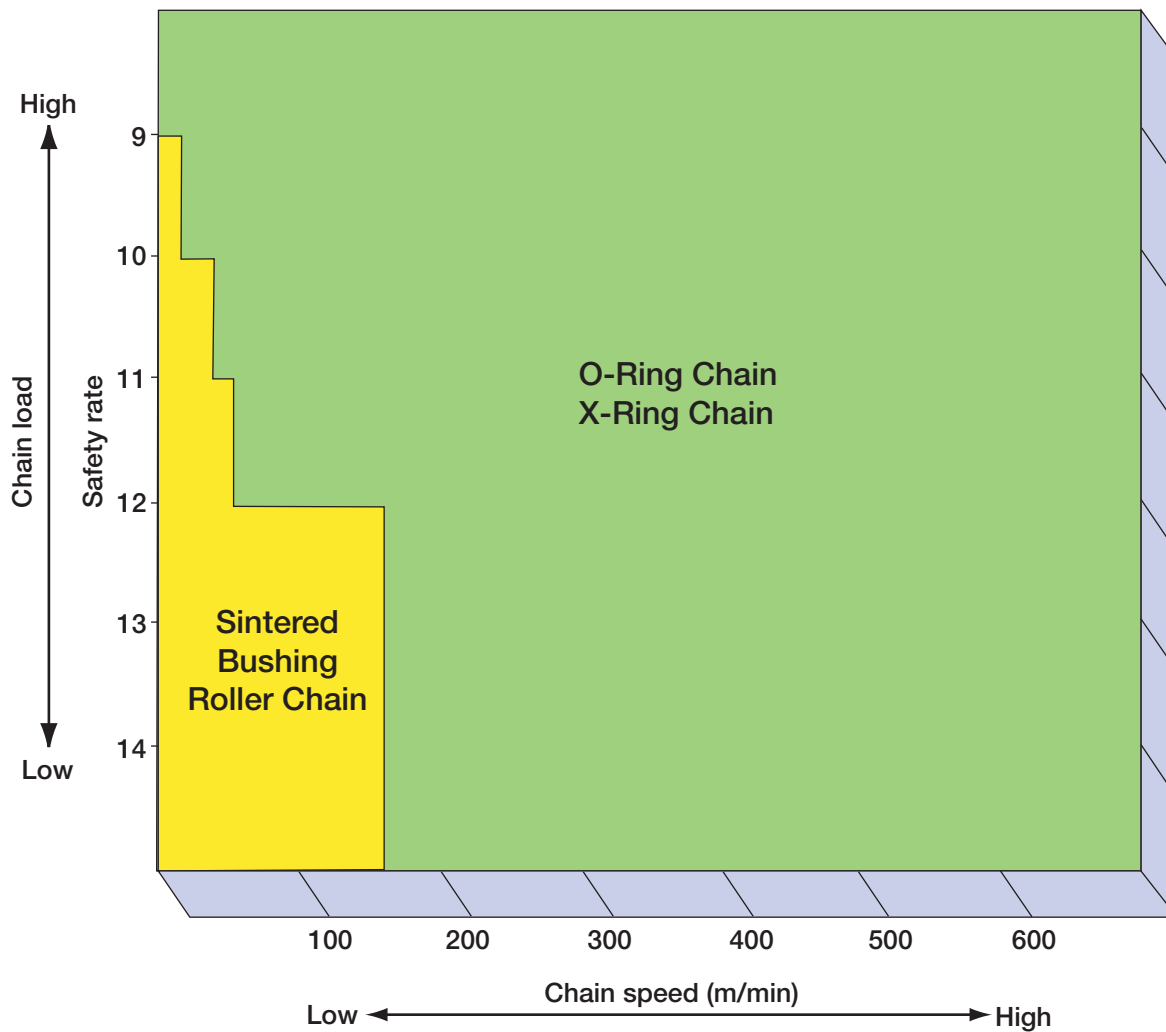



## Life Comparison Test

- **Chain life comparison without lubrication**  
(Compared with standard roller chain as the bench mark)

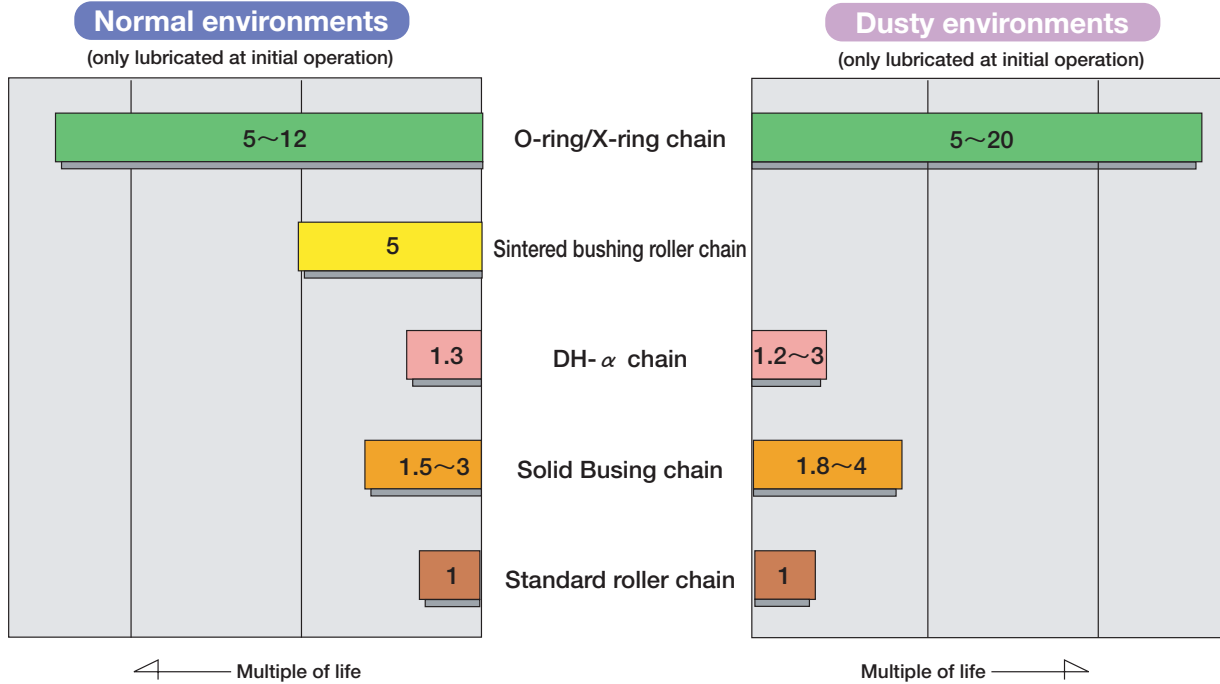

- **Chain life comparison by new oil and deteriorated oil**  
(Compared with standard roller chain as the bench mark)

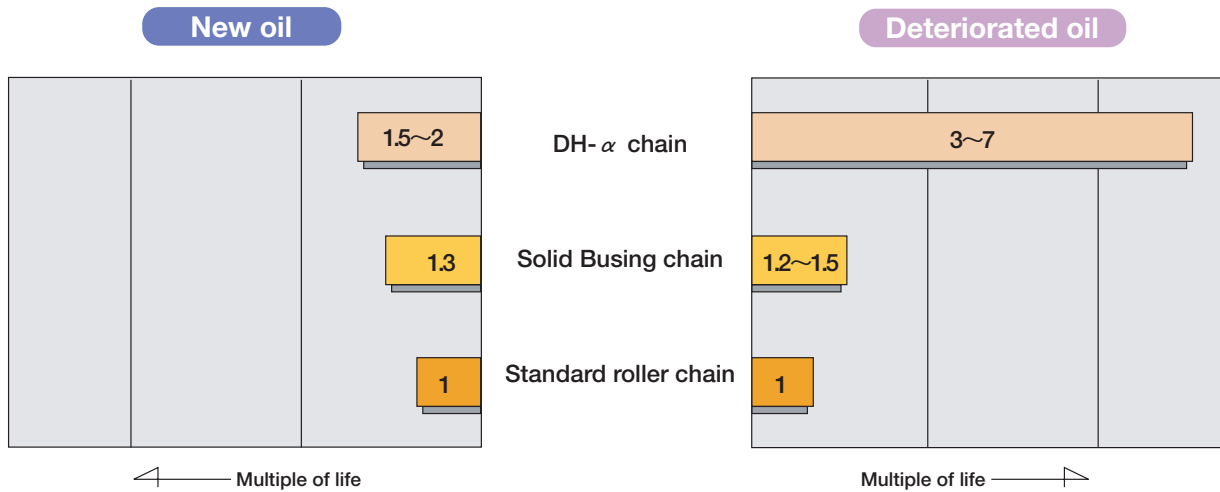

## Solid Bushing Chain (HT/D), (D)

Roller Chains for  
Power Transmission

Ultimate Life  
Chain Series



## Seamless High-precision Solid Bushings Prevent Chain Elongation

Solid Bushing chain is highly wear-resistant using cold formed solid bushings with a seamless smooth surface and complete roundness.

This is the popular type among the Ultimate Life Chain Series with its improved grease retention between the bushing and the pin.

The solid bushings and our patented V grease extend the wear life from up to 4 times compared to standard roller chains. We recommend you to adopt this solid bushing chain if you are wishing to reduce the frequency of maintenance.

### Recommended uses

- For improving wear resistance while retaining the merits of standard roller chains.
- For Circumstances where chain elongation occurs frequently or lubrication is difficult.

\* Wear resistance can be further enhanced when DH- $\alpha$  coating pins are used.

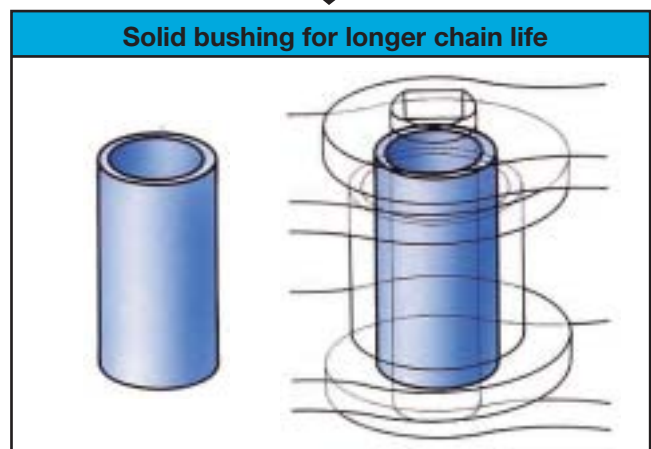
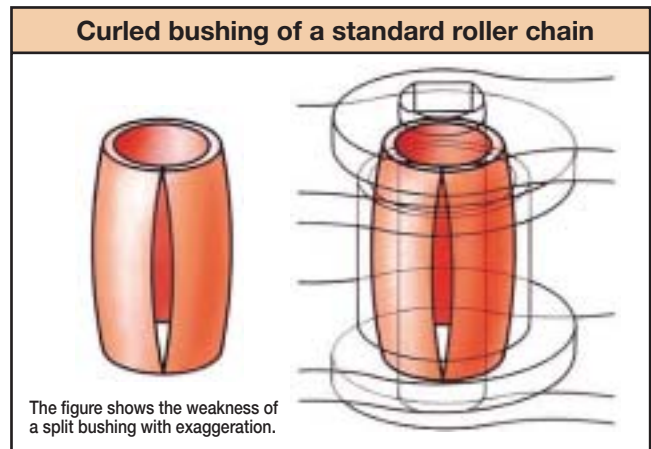



## Wear resistance

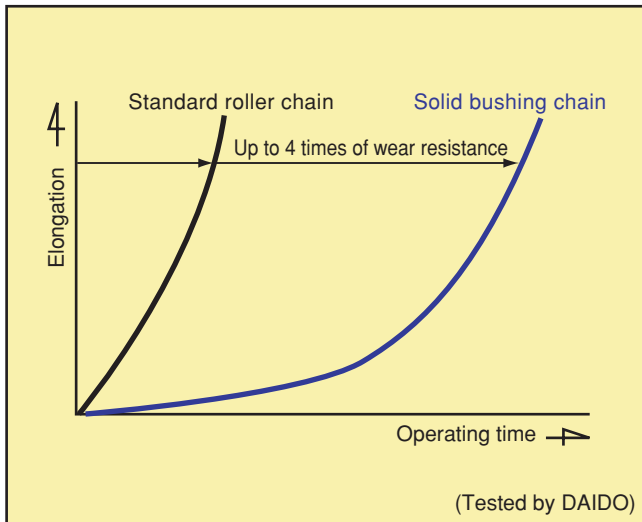

## Selection of chains

The strength of a solid bushing chain is the same as that of standard roller chains. For selecting a suitable chain, refer to "Selection of Chains" (P120~123).

## Connecting links and offset links

R connecting links are used for DID 60 or smaller chains, and C connecting links are used for DID 80 or larger chains. As for offset links, 2POJ is used for DID 25 and DID 35, and both OJ and 2POJ can be used for larger sizes. Standard offset links can be used.

## Sprockets

The dimensions of the solid bushing chain are the same as those of the standard roller chain. The standard sprocket can be used.

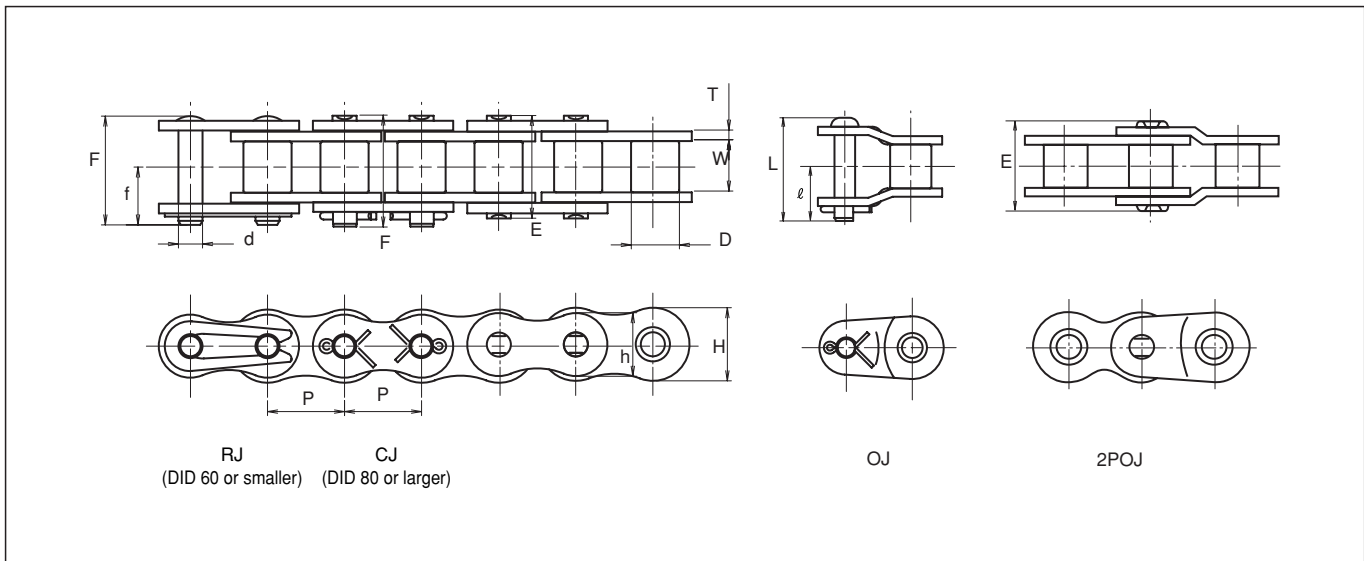

## Dimensions

Unit (mm)

Chain No.	Pitch P	Roller link width W	Roller (Bush) dia. D	Pin						Plate			Avg. tensile strength		Max. allowable load		Approx. weight (kg/m)
				d	E	F	f	L	ℓ	T	H	h	kN	kgf	kN	kgf	
* DID 25HT	6.35	3.18	(3.30)	2.31	9.0	9.5	5.2	—	—	1.00	5.9	5.2	5.88	600	1.07	110	0.16
* DID 35T	9.525	4.78	(5.08)	3.59	12.0	13.1	7.3	13.9	7.8	1.25	9.0	7.75	11.2	1,150	2.15	220	0.32
DID 40D	12.70	7.95	7.92	3.97	16.5	17.6	9.5	19.3	10.6	1.50	12.0	10.4	19.1	1,950	3.72	380	0.63
DID 50D	15.875	9.53	10.16	5.09	20.3	21.9	11.6	23.1	12.1	2.00	15.0	13.0	30.8	3,150	6.86	700	1.06
DID 60D	19.05	12.70	11.91	5.96	25.4	26.9	14.3	30.0	15.7	2.40	18.1	15.6	44.1	4,500	9.31	950	1.44
DID 80D	25.40	15.88	15.88	7.94	32.6	35.4	19.0	36.4	19.5	3.20	24.0	20.8	78.4	8,000	14.7	1,500	2.55
DID 100D	31.75	19.05	19.05	9.54	39.5	42.5	22.8	43.5	23.5	4.00	29.9	26.0	118.0	12,100	22.5	2,300	3.79

Note: 1. Those marked with \* indicate bushing chains.  
2. Consult us for the delivery time.

## DH- $\alpha$ Chain (DHA)



### The pin with a super-hard surface coating protects the critical area from adverse environments

Perfect lubrication makes chain life longer. It is not easy to avoid deterioration due to its own oxidation and mixture with contaminants. In this case, DH- $\alpha$  chain shows good performance. Excellent performance can be expected under non-lubricated conditions and in such critical conditions where dirt, dust or fine metal particles work into the chain.

### Recommended uses

- Environments where soil, sand or dust directly comes into contact with the chain (O-ring chains are recommended if applicable.).
- Applications where a chain is lubricated in an oil bath and the oil is heavily deteriorated due to the contamination of foreign objects.
- To avoid chain kinking by heat between pin and bushing.

### Wear resistance performance

#### I . Wear resistance performance under degraded lubricant condition

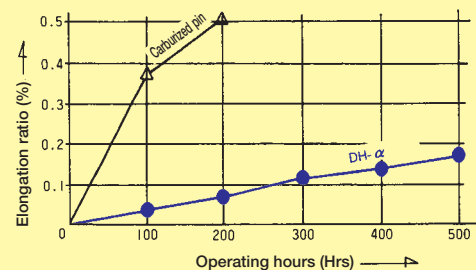

(Test conditions)

- ① Chain Sample: DID06B (p=9.525)
- ② Drive: 14N.T/10,000rpm-33N.T/ 4242rpm
- ③ Tension: 30kgf (6.0kW)
- ④ Lubrication: By oil bath with wasted automobile engine oil

#### II . Wear resistance performance under sandy & dusty condition

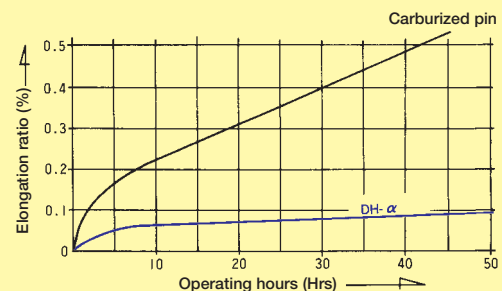

(Test conditions)

- ① Chain Sample: DID40 (p=12.70)
- ② Drive: 21N.T/ 1090rpm-21N.T/ 1090rpm
- ③ Tension: 140kgf (6.8kW)
- ④ Lubrication: Initial grease only. Continuous scattering of sand on the chain in operation

Tested by DAIDO



## Comparison of properties

	Carburizing	Nitriding	H-Cr plating	DH- $\alpha$
Layer	High carbon	Iron nitride	Chrome	Chrome carbide
Surface hardness (HV)	750~850	750~1,100	900~1,100	1,300~1,500
Actual thickness of treated layer	100 or more	10 or more	10~100	5~20
Surface hardness lowering temperature	200 or more	500 or more	300 or more	900 or more
Peeling resistance	○	○	×	◎
Wear resistance	△	○	○	◎

## Structure of DH- $\alpha$

DH- $\alpha$  refers to a hard layer formed on the surface of a pin. This layer contains harder carbide as illustrated below, so it provides excellent wear resistance even in the use for adverse conditions such as the contamination of hard foreign objects as well as in oxidation resistance. (Patented)

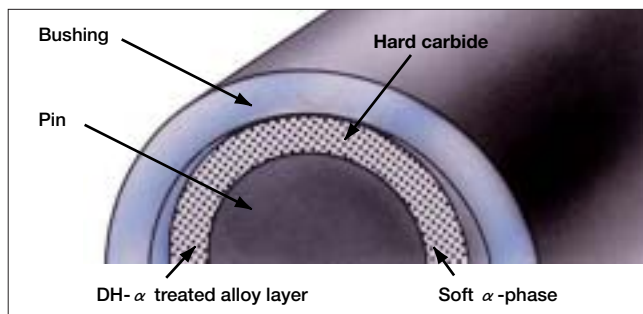

## Selection of chains

The strength of DH- $\alpha$  chain is the same as that of standard roller chains. For selecting a suitable DH- $\alpha$  chain, refer to "Selection of Chains" (P120~123).

## Connecting links and offset links

Use the connecting links and offset links for standard roller chains. While a chain has many links, the numbers of connecting link and offset link is 1 or 2, and, therefore, their influence on the wear of the entire chain is small.

## Sprockets

The dimensions of DH- $\alpha$  chain is the same as those of standard roller chains. Use standard sprockets for standard roller chains.

## Microstructure



The white layer is a layer by DH- $\alpha$  treatment, and the black grains visible in the layer are chromium carbide.

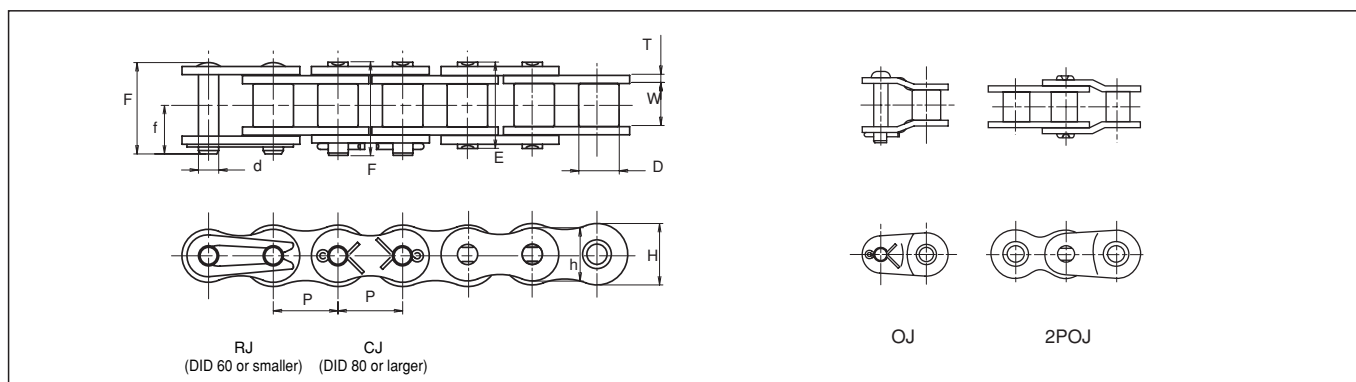

## Dimensions

Chain No.	Pitch P	Roller link width W	Roller (Bush) dia. D	Pin						Plate			Avg. tensile strength		Max. allowable load		Approx. weight (kg/m)
				d	E	F	f	L	l	T	H	h	kN	kgf	kN	kgf	
* DID 25 DHA	6.35	3.18	(3.30)	2.31	7.8	8.5	4.7	—	—	0.72	5.9	5.20	4.41	450	0.73	75	0.13
* DID 35 DHA	9.525	4.78	(5.08)	3.59	12.0	13.1	7.3	13.9	7.8	1.25	9.0	7.75	11.2	1,150	2.15	220	0.32
DID 41 DHA	12.70	6.38	7.77	3.59	13.7	14.6	7.9	15.2	8.6	1.20	9.6	8.00	10.7	1,100	2.35	240	0.39
DID 40 DHA	12.70	7.95	7.92	3.97	16.5	17.6	9.5	19.3	10.6	1.50	12.0	10.40	19.1	1,950	3.72	380	0.63
DID 50 DHA	15.875	9.53	10.16	5.09	20.3	21.9	11.6	23.1	12.1	2.00	15.0	13.00	30.9	3,150	6.86	700	1.06
DID 60 DHA	19.05	12.70	11.91	5.96	25.4	26.9	14.3	30.0	15.7	2.40	18.1	15.60	44.1	4,500	9.31	950	1.44

Note: Those marked with \* indicate bushing chains.



## O-Ring Chain (LD)/X-Ring Chain (LX)



### Highest wear resistance available by sealing grease between pins and bushings

The durability of chain is dramatically improved since grease is sealed between the pins and bushings by O-rings. The O-ring chain is the most dependable model of the Ultimate Life Chain Series with its excellent wear resistance even in the conditions or environments where chain maintenance is difficult.

#### Recommended uses.

- Circumstances where frequent chain replacement is required due to wear stretch
- Circumstances where lubrication during the service is impossible

- In an environment with much soil, sand, dust, etc.
- Applications that require strength higher than that of a sintered bushing roller chain

#### Other features

- Reducing noise. (The noise level is 3 dB lower compared to standard roller chains.)
- Reducing vibration with the friction created by O-Ring. (The power loss due to the friction is almost negligible, since the frictional force between the pins and bushings is for usually in the applications.)

#### Wear resistance performance

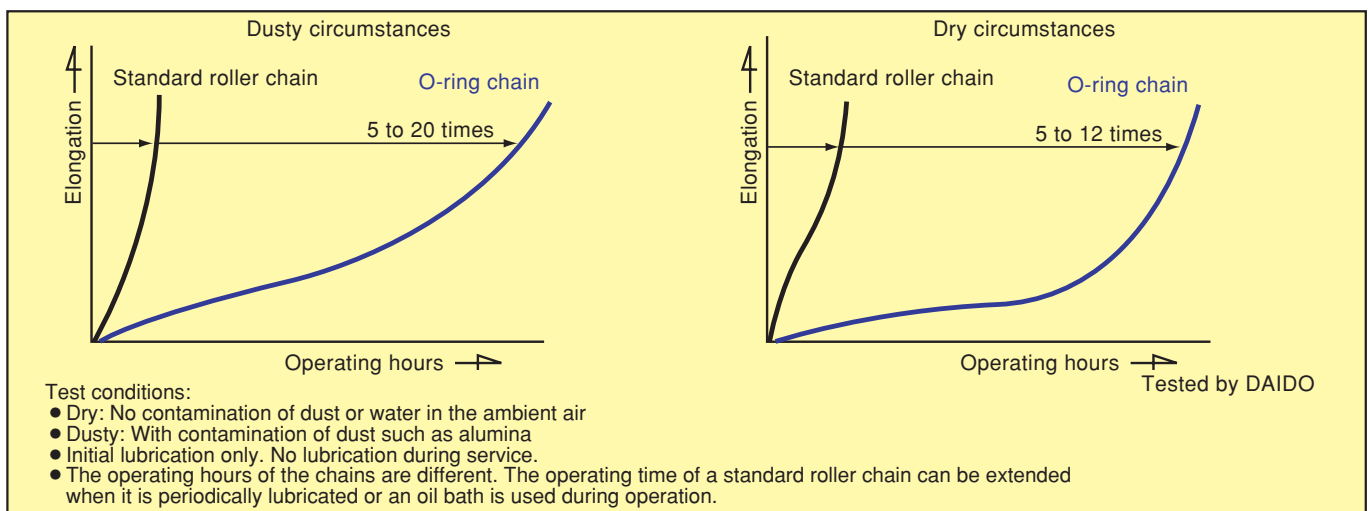



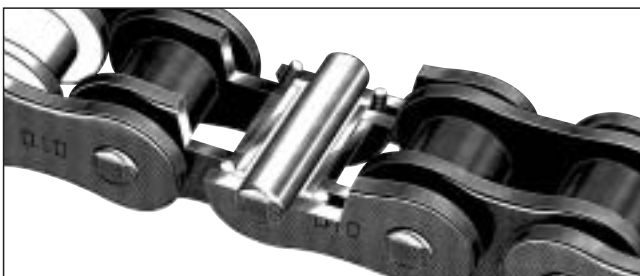

## Selection of chains

The strength of an O-ring chain is almost the same as that of a standard roller chain. (Since the pins are longer than those of standard roller chain, the average rupture strength is slightly lower.)

For selecting a suitable chain, refer to "Selection of Chains" (P120~123).

When the service ambient temperature is higher than 80 °C, special heat resistant O-rings must be used. In this case, contact us for more information.

## Connecting links and offset links

Two types of connecting links are available: clearance fit and interference fit. When high strength or durability is required, use interference-fit connecting link. Only 2POJ is available as the offset link for all sizes.

Chain No.	Connecting link		Offset link
	Clearance fit	Interference fit	
<b>DID 35LD</b>	RJ (D clip type)	FJ (D clip type)	2POJ ( 2 pitch offset link )
<b>DID 40LX</b> <b>DID 50LX</b> <b>DID 60LX</b>	RJ (M clip type)	FJ (M clip type)	
<b>DID 80LD</b> <b>DID 100LD</b>	CJ (Cotter pin type)	HJ (Cotter pin type)	
<b>DID 120LD</b>	—	—	
<b>DID 140LD</b> <b>DID 160LD</b> <b>DID 200LD</b> <b>DID 240LD</b>	—	BJ (Cotter pin type, with nut)	

## Sprockets

O-ring chain uses longer pins than a standard roller chain. When using multiplex O-ring chain, the standard sprocket for multiplex chains cannot be used.

## Caution

O-ring chain is not recommended in applications where solvents or other substances may attack "Nitric Rubber". Special material O-rings are also available for these conditions: Please consult us for details. In general, "Nitric Rubber" is damaged by contact with the following chemical materials.

Gasoline, Light oil, Benzene, Toluene, Trichloroethylene, Ether, Ketone (MEK), Ethyl acetate, Phosphoric acid, Ester hydraulic oil, Organic acid, High-concentration inorganic acid

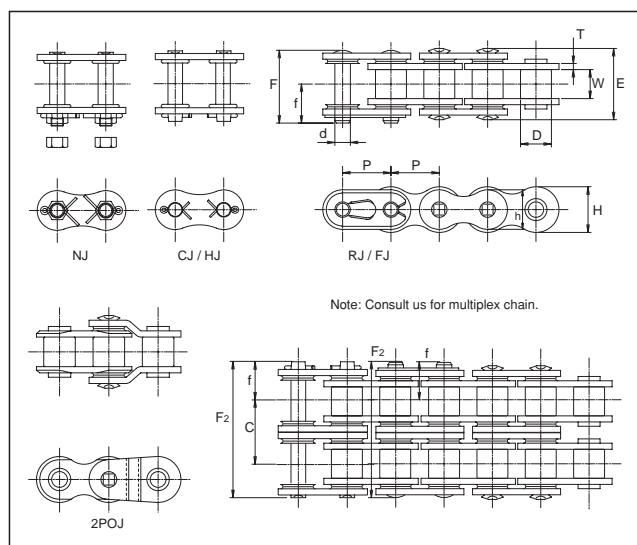

## Dimensions

Unit (mm)

Chain No.	Pitch P	Roller link width W	Roller (Bush) dia. D	Pin				Plate			Avg. tensile strength		Max. allowable tension		Approx. weight (kg/m)
				d	E	F	f	T	H	h	kN	kgf	kN	kgf	
* <b>DID 35 LD</b>	9.525	4.60	(5.08)	3.59	13.0	14.45	7.8	1.25	9.0	7.75	9.8	1,000	1.47	150	0.35
<b>DID 40 LX</b>	12.70	7.95	7.92	3.97	20.0	20.0	10.7	1.5	12.0	10.4	18.1	1,850	3.72	380	0.67
<b>DID 50 LX</b>	15.875	9.53	10.16	5.09	23.4	23.9	12.8	2.0	15.0	13.0	30.1	3,070	6.86	700	1.08
<b>DID 60 LX</b>	19.05	12.70	11.91	5.96	29.2	30.0	16.0	2.4	18.1	15.6	42.8	4,370	9.31	950	1.62
<b>DID 80 LD</b>	25.40	15.88	15.88	7.94	36.5	38.9	20.9	3.2	24.0	20.6	72.5	7,400	14.7	1,500	2.83
<b>DID 100 LD</b>	31.75	19.05	19.05	9.54	44.0	46.2	24.7	4.0	29.9	26.0	107.0	11,000	22.5	2,300	4.07
<b>DID 120 LD</b>	38.10	25.40	22.23	11.11	54.0	56.8	30.2	4.8	35.9	31.2	156.9	16,000	30.4	3,100	5.90
<b>DID 140 LD</b>	44.45	25.40	25.40	12.71	58.6	69.2	40.2	5.6	41.9	36.3	196	20,000	40.2	4,100	7.87
<b>DID 160 LD</b>	50.80	31.75	28.58	14.29	69.0	80.3	46.2	6.4	47.8	41.4	245	25,000	52.9	5,400	10.31
<b>DID 200 LD</b>	63.50	38.10	39.68	19.85	83.8	96.5	55.0	8.0	60.0	52.0	428	43,700	73.5	7,500	16.89
<b>DID 240 LD</b>	76.20	47.63	47.63	23.81	101.2	116.4	66.2	9.5	71.5	62.0	624	63,700	99.0	10,100	24.80

Note: 1. Those marked with \* indicate bushing chain.

2. The values of average tensile strength and maximum allowable load are for chains.

3. When grooving using sprockets with smaller number of teeth, the grooves may interfere with the chain outer plate. Consult us for advise.

4. LX-type is a less-friction O-ring chain using specially formed X-rings.

## Sintered Bushing Roller Chain (UR/ URN)



### Maintenance free chains using sintered alloy bushings

Sintered bushing roller chain is maintenance-free chain suitable to a place where lubrication is difficult. It uses bushings made of a sintered alloy which impregnates lubricating oil.

For the use that requires clean appearance, rustless type (URN) is available.

#### Recommended uses

- Circumstances where lubrication is difficult or elongation of chain frequently occurs

#### Remarks for use

- Don't use this chain in dusty environments. In such environments, use O-ring chains.
- This chain is for the use under light or medium load. Use O-ring chain when a large impact is applied to a chain.
- Set the chain feeding speed at 150m/min. or lower.

#### Wear resistance performance

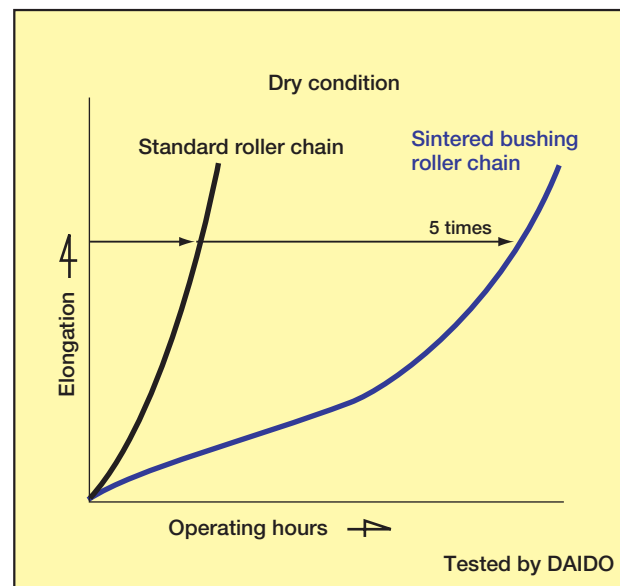



Tensile strength index  
**70%**

Temperature Range in Use  
**-10°C~60°C**

FOOD

PACK

TEXTILE

PRINT

CONVEYOR

HOME APPLIANCE

## Selection of chains

As for sintered bushing roller chains, the inner plates are thicker and the pins are longer than those of standard roller chains in order to compensate for the strength lowered by the use of sintered bushings.

For selecting a suitable chain, refer to "Selection of Chains" (P120~123). Use the tables of maximum kilowatt ratings for sintered bushing roller chains that cover low speed ranges (P76~79).

For sintered bushing roller chains, "Low-speed selection" cannot be used since the "Maximum allowable load" in the dimension table considers only the chain tensile tension and neglects the bushing strength.

## Connecting links and offset links

For sintered bushing roller chain, R connecting links are used for DID60 or smaller, and C connecting links for DID80 or larger.

OJ can be used as offset links. Please place an order the connecting links and offset links specifying the type for sintered bushing roller chain.

In the tables of maximum kilowatt ratings, the strength of the connecting links and offset links are taken into account.

## Sprockets

Standard sprockets can be used for sintered bushing roller chains.

## Sectional view of sintered alloy

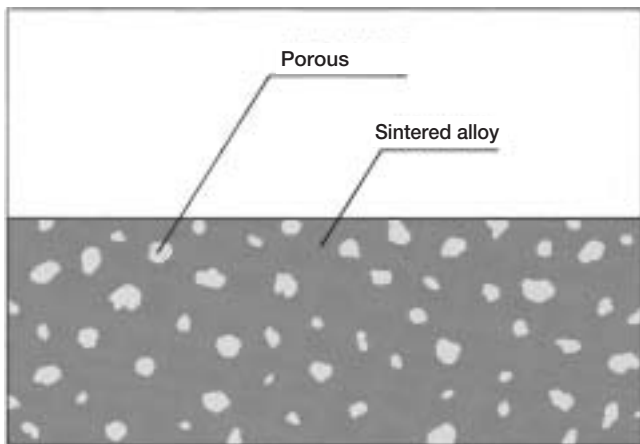

## DID 40UR, 40URN

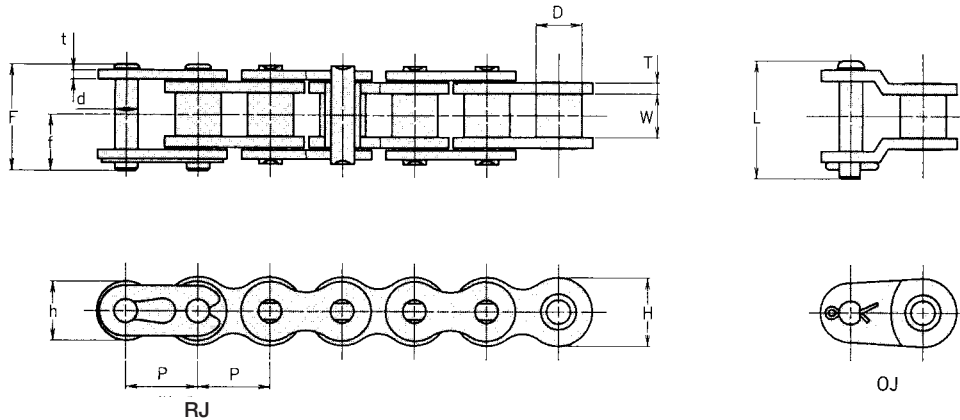

### Dimensions

Unit (mm)

Chain No.	Pitch <b>P</b>	Roller link width <b>W</b>	Roller dia. <b>D</b>	Pin				Plate				Avg. tensile strength		Max. allowable load		Approx. weight (kg/m)
				<b>d</b>	<b>F</b>	<b>f</b>	<b>L</b>	<b>T</b>	<b>t</b>	<b>H</b>	<b>h</b>	kN	kgf	kN	kgf	
<b>DID 40UR, URN</b>	12.70	7.95	7.92	3.97	19.0	10.4	20.5	2.0	1.5	12.0	10.4	17.8	1,820	3.72	380	0.69

Note: The values of average tensile strength and maximum allowable load are for chains.

### Max. Kilowatt Ratings DID 40UR, 40URN

Unit(kW)

N. T	Small sprocket rpm (r/min)																			
	10	20	30	50	70	90	100	150	200	300	400	500	600	700	800	900	1000	1100	1200	1300
<b>9</b>	0.04	0.07	0.10	0.16	0.22	0.27	0.30	0.43	0.56	0.81	1.05	1.28	1.51	1.74	1.96	2.18	2.40	2.27	1.99	1.76
<b>10</b>	0.04	0.08	0.11	0.18	0.25	0.31	0.34	0.49	0.63	0.91	1.18	1.44	1.70	1.95	2.20	2.44	2.69	2.65		
<b>11</b>	0.05	0.09	0.13	0.20	0.27	0.34	0.37	0.54	0.70	1.01	1.30	1.60	1.88	2.16	2.44	2.71	2.98			
<b>12</b>	0.05	0.10	0.14	0.22	0.30	0.37	0.41	0.59	0.77	1.11	1.43	1.75	2.06	2.37	2.67	2.97				
<b>13</b>	0.06	0.11	0.15	0.24	0.33	0.41	0.45	0.65	0.84	1.21	1.56	1.91	2.25	2.59	2.92	3.24				
<b>14</b>	0.06	0.11	0.16	0.26	0.35	0.44	0.49	0.70	0.91	1.31	1.69	2.07	2.44	2.80	3.16					
<b>15</b>	0.07	0.12	0.18	0.28	0.38	0.48	0.52	0.75	0.98	1.41	1.82	2.23	2.63	3.02						
<b>16</b>	0.07	0.13	0.19	0.30	0.41	0.51	0.56	0.81	1.05	1.51	1.96	2.39	2.82	3.24						
<b>17</b>	0.08	0.14	0.20	0.32	0.44	0.55	0.60	0.86	1.12	1.61	2.09	2.55	3.01							
<b>18</b>	0.08	0.15	0.22	0.34	0.46	0.58	0.64	0.92	1.19	1.71	2.22	2.72	3.20							
<b>19</b>	0.09	0.16	0.23	0.36	0.49	0.62	0.68	0.97	1.26	1.82	2.35	2.88	3.39							
<b>20</b>	0.09	0.17	0.24	0.38	0.52	0.65	0.71	1.03	1.33	1.92	2.49	3.04								
<b>21</b>	0.09	0.18	0.25	0.40	0.55	0.69	0.75	1.09	1.41	2.03	2.62	3.21								
<b>22</b>	0.10	0.19	0.27	0.42	0.57	0.72	0.79	1.14	1.48	2.13	2.76	3.37								
<b>23</b>	0.10	0.20	0.28	0.45	0.60	0.76	0.83	1.20	1.55	2.23	2.89	3.54								
<b>24</b>	0.11	0.20	0.29	0.47	0.63	0.79	0.87	1.25	1.62	2.34	3.03									
<b>25</b>	0.11	0.21	0.31	0.49	0.66	0.83	0.91	1.31	1.70	2.44	3.17									
<b>28</b>	0.13	0.24	0.35	0.55	0.75	0.93	1.03	1.48	1.92	2.76	3.58									
<b>30</b>	0.14	0.26	0.37	0.59	0.80	1.01	1.11	1.60	2.07	2.98										
<b>32</b>	0.15	0.28	0.40	0.64	0.86	1.08	1.19	1.71	2.22	3.19										
<b>35</b>	0.16	0.31	0.44	0.70	0.95	1.19	1.31	1.88	2.44	3.52										
<b>40</b>	0.19	0.35	0.51	0.81	1.10	1.37	1.51	2.18	2.82											

Note: The drive performance (kilowatt ratings) of sintered bushing chains is obtained on the basis of approx. 1,000 hour endurance time.

# DID 50UR, 50URN

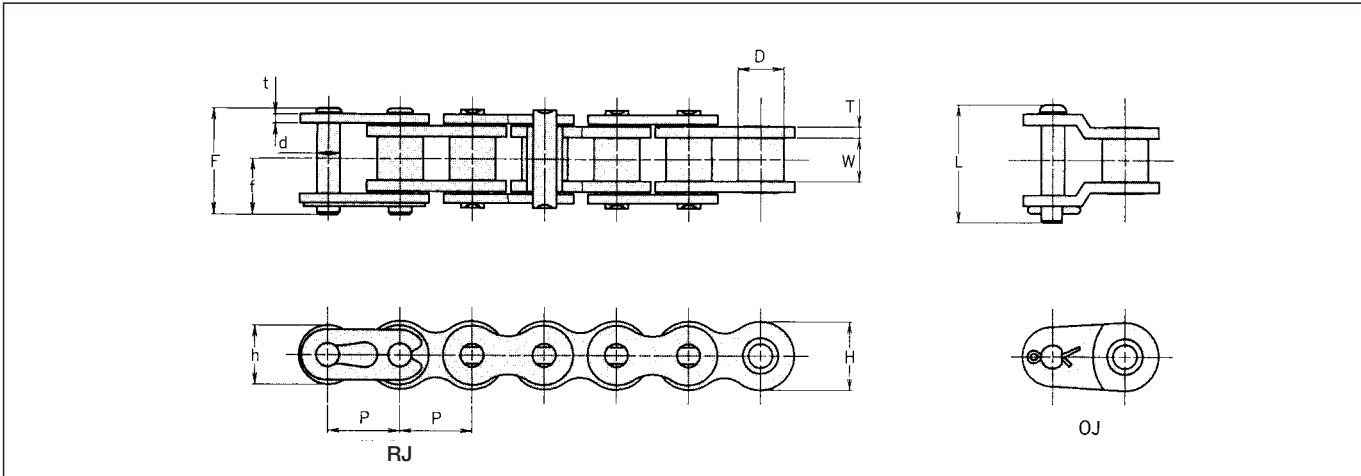

## Dimensions

Unit (mm)

Chain No.	Pitch <b>P</b>	Roller link width <b>W</b>	Roller dia. <b>D</b>	Pin				Plate				Avg. tensile strength		Max. allowable load		Approx. weight (kg/m)
				<b>d</b>	<b>F</b>	<b>f</b>	<b>L</b>	<b>T</b>	<b>t</b>	<b>H</b>	<b>h</b>	kN	kgf	kN	kgf	
<b>DID 50UR, URN</b>	15.875	9.53	10.16	5.09	22.8	12.3	25.0	2.4	2.0	15.0	13.0	29.9	3,050	6.86	700	1.09

Note: The values of average tensile strength and maximum allowable load are for chains.

## DID 50UR, 50URN (kW Ratings)

Unit(kW)

Z -1	Small sprocket rpm (r/min)																			
	10	20	30	50	70	90	100	150	200	250	300	350	400	450	500	600	700	800	900	1000
<b>9</b>	0.09	0.17	0.24	0.39	0.53	0.66	0.72	1.04	1.35	1.65	1.95	2.23	2.52	2.80	3.08	3.63	4.17	4.37	3.66	3.12
<b>10</b>	0.10	0.19	0.27	0.43	0.59	0.74	0.81	1.17	1.51	1.85	2.18	2.50	2.82	3.14	3.45	4.07	4.67	5.11	4.29	
<b>11</b>	0.11	0.21	0.30	0.48	0.65	0.82	0.90	1.29	1.68	2.05	2.42	2.78	3.13	3.48	3.83	4.51	5.18	5.84		
<b>12</b>	0.12	0.23	0.33	0.53	0.72	0.90	0.99	1.42	1.84	2.25	2.65	3.05	3.44	3.82	4.20	4.95	5.69			
<b>13</b>	0.14	0.25	0.36	0.58	0.78	0.98	1.08	1.55	2.01	2.46	2.89	3.32	3.75	4.17	4.58	5.40	6.20			
<b>14</b>	0.15	0.27	0.39	0.63	0.85	1.06	1.17	1.68	2.18	2.66	3.14	3.60	4.06	4.52	4.96	5.85				
<b>15</b>	0.16	0.30	0.43	0.67	0.91	1.14	1.26	1.81	2.34	2.87	3.38	3.88	4.38	4.87	5.35	6.30				
<b>16</b>	0.17	0.32	0.46	0.72	0.98	1.23	1.35	1.94	2.51	3.07	3.62	4.16	4.69	5.22	5.74					
<b>17</b>	0.18	0.34	0.49	0.77	1.04	1.31	1.44	2.07	2.68	3.28	3.87	4.44	5.01	5.57	6.12					
<b>18</b>	0.19	0.36	0.52	0.82	1.11	1.39	1.53	2.20	2.86	3.49	4.11	4.72	5.33	5.92	6.51					
<b>19</b>	0.20	0.38	0.55	0.87	1.18	1.48	1.62	2.34	3.03	3.70	4.36	5.01	5.65	6.28						
<b>20</b>	0.22	0.40	0.58	0.92	1.24	1.56	1.71	2.47	3.20	3.91	4.61	5.29	5.97	6.64						
<b>21</b>	0.23	0.42	0.61	0.97	1.31	1.64	1.81	2.60	3.37	4.12	4.86	5.58	6.29							
<b>22</b>	0.24	0.45	0.64	1.02	1.38	1.73	1.90	2.74	3.55	4.34	5.11	5.87	6.62							
<b>23</b>	0.25	0.47	0.67	1.07	1.45	1.81	1.99	2.87	3.72	4.55	5.36	6.16	6.94							
<b>24</b>	0.26	0.49	0.71	1.12	1.51	1.90	2.09	3.01	3.90	4.76	5.61	6.45								
<b>25</b>	0.27	0.51	0.74	1.17	1.58	1.98	2.18	3.14	4.07	4.98	5.86	6.74								
<b>28</b>	0.31	0.58	0.83	1.32	1.79	2.24	2.47	3.55	4.60	5.62	6.63									
<b>30</b>	0.33	0.62	0.90	1.42	1.93	2.42	2.66	3.83	4.96	6.06	7.14									
<b>32</b>	0.36	0.67	0.96	1.53	2.07	2.59	2.85	4.10	5.32	6.50										
<b>35</b>	0.40	0.74	1.06	1.68	2.28	2.85	3.14	4.52	5.86	7.16										
<b>40</b>	0.46	0.85	1.23	1.94	2.63	3.30	3.62	5.22	6.76											

Note: The drive performance (kilowatt ratings) of sintered bushing chains is obtained on the basis of approx. 1,000 hour endurance time.

## DID 60UR, 60URN

Roller Chains for Power Transmission  
Ultimate Life Chain Series

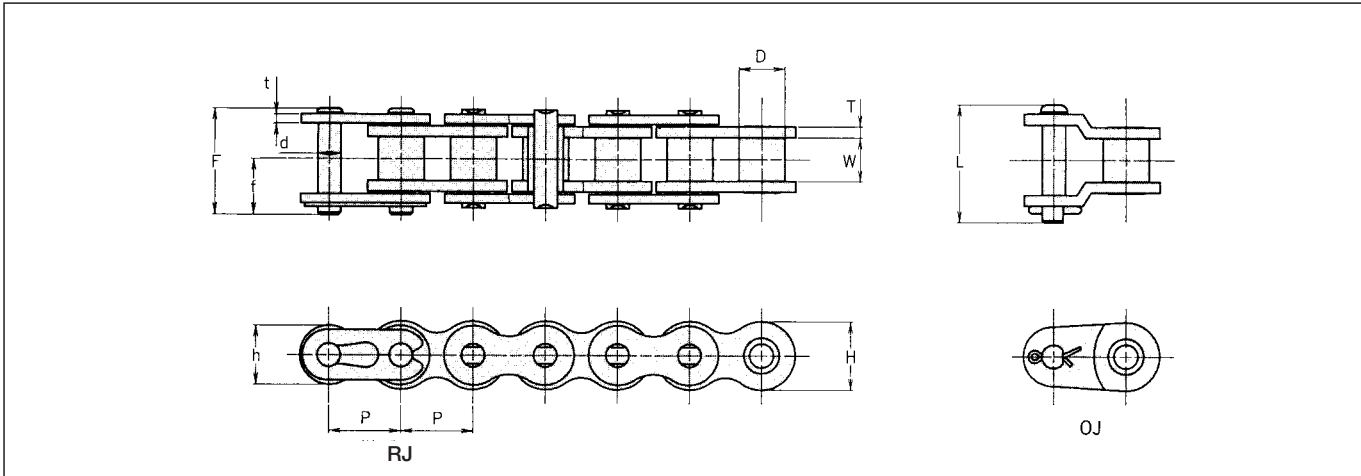

### Dimensions

Unit (mm)

Chain No.	Pitch <b>P</b>	Roller link width <b>W</b>	Roller dia. <b>D</b>	Pin				Plate				Avg. tensile strength		Max. allowable load		Approx. weight (kg/m)
				<b>d</b>	<b>F</b>	<b>f</b>	<b>L</b>	<b>T</b>	<b>t</b>	<b>H</b>	<b>h</b>	kN	kgf	kN	kgf	
<b>DID 60UR, URN</b>	19.05	12.70	11.91	5.96	28.9	15.8	33.1	3.2	2.4	18.1	15.6	42.1	4,300	9.31	950	1.71

Note: The values of average tensile strength and maximum allowable load are for chains.

### DID 60UR, 60URN (kW Ratings)

Unit(kW)

N. T	Small sprocket rpm (r/min)																			
	10	20	30	50	70	90	100	150	200	250	300	350	400	450	500	550	600	650	700	800
<b>9</b>	0.14	0.27	0.38	0.61	0.82	1.03	1.13	1.63	2.11	2.58	3.04	3.49	3.94	4.38	4.81	5.24	5.67	6.10	6.17	5.05
<b>10</b>	0.16	0.30	0.43	0.68	0.92	1.15	1.27	1.83	2.36	2.89	3.41	3.91	4.41	4.91	5.39	5.88	6.36	6.83	7.23	
<b>11</b>	0.18	0.33	0.48	0.75	1.02	1.28	1.40	2.02	2.62	3.20	3.78	4.34	4.89	5.44	5.98	6.51	7.04	7.57	8.09	
<b>12</b>	0.19	0.36	0.52	0.83	1.12	1.40	1.54	2.22	2.88	3.52	4.15	4.76	5.37	5.97	6.57	7.16	7.74	8.32		
<b>13</b>	0.21	0.40	0.57	0.90	1.22	1.53	1.68	2.42	3.14	3.84	4.52	5.19	5.86	6.51	7.16	7.80	8.44			
<b>14</b>	0.23	0.43	0.62	0.98	1.32	1.66	1.82	2.62	3.40	4.16	4.90	5.63	6.35	7.06	7.76	8.45				
<b>15</b>	0.25	0.46	0.66	1.05	1.42	1.79	1.96	2.83	3.66	4.48	5.28	6.06	6.84	7.60	8.36					
<b>16</b>	0.27	0.49	0.71	1.13	1.53	1.91	2.11	3.03	3.93	4.80	5.66	6.50	7.33	8.15						
<b>17</b>	0.28	0.53	0.76	1.20	1.63	2.04	2.25	3.24	4.19	5.13	6.04	6.94	7.83	8.70						
<b>18</b>	0.30	0.56	0.81	1.28	1.73	2.17	2.39	3.44	4.46	5.45	6.43	7.38	8.32							
<b>19</b>	0.32	0.60	0.86	1.36	1.84	2.31	2.53	3.65	4.73	5.78	6.81	7.83	8.83							
<b>20</b>	0.34	0.63	0.91	1.44	1.94	2.44	2.68	3.86	5.00	6.11	7.20	8.27								
<b>21</b>	0.36	0.66	0.96	1.51	2.05	2.57	2.82	4.07	5.27	6.44	7.59	8.72								
<b>22</b>	0.37	0.70	1.00	1.59	2.15	2.70	2.97	4.28	5.54	6.77	7.98	9.17								
<b>23</b>	0.39	0.73	1.05	1.67	2.26	2.83	3.12	4.49	5.81	7.11	8.37									
<b>24</b>	0.41	0.77	1.10	1.75	2.37	2.97	3.26	4.70	6.09	7.44	8.77									
<b>25</b>	0.43	0.80	1.15	1.83	2.47	3.10	3.41	4.91	6.36	7.78	9.16									
<b>28</b>	0.48	0.91	1.30	2.06	2.79	3.50	3.85	5.55	7.19	8.79										
<b>30</b>	0.52	0.98	1.40	2.22	3.01	3.77	4.15	5.98	7.75	9.47										
<b>32</b>	0.56	1.05	1.51	2.38	3.23	4.05	4.45	6.41	8.30											
<b>35</b>	0.62	1.15	1.66	2.63	3.56	4.46	4.90	7.06	9.15											
<b>40</b>	0.71	1.33	1.92	3.03	4.11	5.15	5.66	8.16												

Note: The drive performance (kilowatt ratings) of sintered bushing chains is obtained on the basis of approx. 1,000 hour endurance time.



# DID 80UR, 80URN

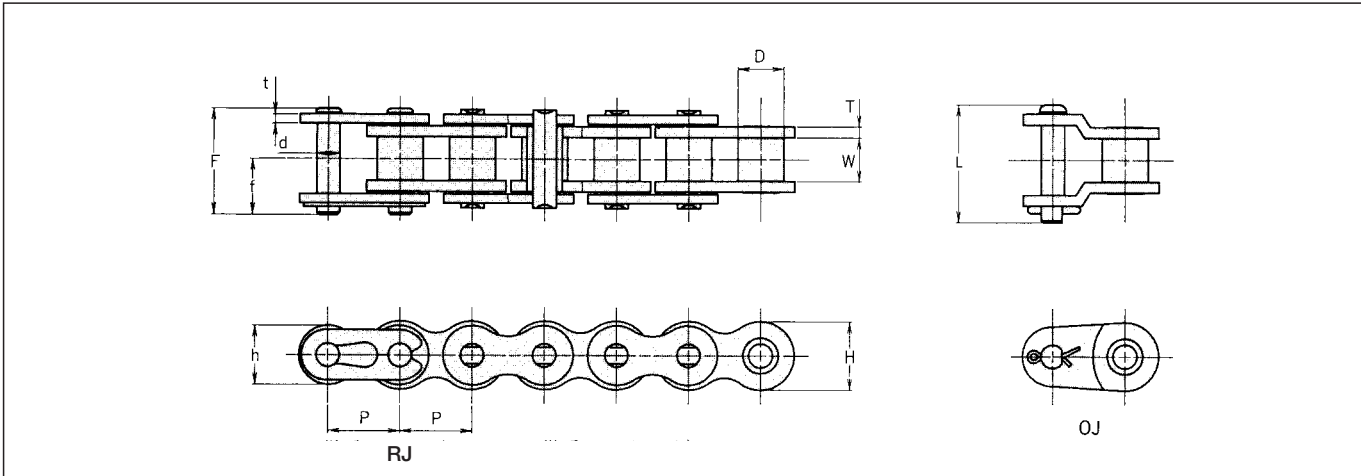

## Dimensions

Unit (mm)

Chain No.	Pitch P	Roller link width W	Roller dia. D	Pin				Plate				Avg. tensile strength		Max. allowable load		Approx. weight (kg/m)
				d	F	f	L	T	t	H	h	kN	kgf	kN	kgf	
<b>DID 80UR, URN</b>	25.40	15.88	15.88	7.94	37.1	20.0	39.7	4.0	3.2	24.0	20.8	77.0	7,850	14.7	1,500	2.80

Note: The values of average tensile strength and maximum allowable load are for chains.

## DID 80UR, 80URN (kW Ratings)

Unit(kW)

N. T	Small sprocket rpm (r/min)																					
	10	20	30	40	50	60	70	80	90	100	120	140	160	180	200	250	300	400	450	500	550	600
<b>9</b>	0.35	0.64	0.93	1.20	1.47	1.73	1.99	2.24	2.49	2.74	3.23	3.71	4.19	4.65	5.12	6.25	7.37	9.55	10.62	11.67	11.16	9.79
<b>10</b>	0.39	0.72	1.04	1.35	1.65	1.94	2.23	2.51	2.79	3.07	3.62	4.16	4.69	5.21	5.73	7.01	8.26	10.70	11.89	13.08	13.07	
<b>11</b>	0.43	0.80	1.15	1.49	1.82	2.15	2.47	2.79	3.10	3.41	4.01	4.61	5.20	5.78	6.35	7.77	9.15	11.86	13.18	14.50		
<b>12</b>	0.47	0.88	1.27	1.64	2.00	2.36	2.71	3.06	3.40	3.74	4.41	5.06	5.71	6.35	6.98	8.53	10.05	13.03	14.48			
<b>13</b>	0.51	0.96	1.38	1.79	2.19	2.58	2.96	3.34	3.71	4.08	4.81	5.52	6.23	6.92	7.61	9.30	10.96	14.20	15.79			
<b>14</b>	0.56	1.04	1.50	1.94	2.37	2.79	3.21	3.61	4.02	4.42	5.21	5.98	6.74	7.50	8.25	10.08	11.88	15.39				
<b>15</b>	0.60	1.12	1.61	2.09	2.55	3.01	3.45	3.89	4.33	4.76	5.61	6.44	7.27	8.08	8.88	10.86	12.80					
<b>16</b>	0.64	1.20	1.73	2.24	2.74	3.22	3.70	4.18	4.64	5.10	6.01	6.91	7.79	8.66	9.52	11.64	13.72					
<b>17</b>	0.69	1.28	1.84	2.39	2.92	3.44	3.95	4.46	4.96	5.45	6.42	7.38	8.32	9.25	10.17	12.43	14.65					
<b>18</b>	0.73	1.36	1.96	2.54	3.11	3.66	4.20	4.74	5.27	5.80	6.83	7.85	8.85	9.84	10.82	13.22	15.58					
<b>19</b>	0.77	1.44	2.08	2.69	3.29	3.88	4.46	5.03	5.59	6.14	7.24	8.32	9.38	10.43	11.47	14.02	16.52					
<b>20</b>	0.82	1.53	2.20	2.85	3.48	4.10	4.71	5.31	5.91	6.49	7.65	8.79	9.91	11.02	12.12	14.82						
<b>21</b>	0.86	1.61	2.32	3.00	3.67	4.32	4.97	5.60	6.23	6.85	8.07	9.27	10.45	11.62	12.78	15.62						
<b>22</b>	0.91	1.69	2.44	3.16	3.86	4.55	5.22	5.89	6.55	7.20	8.48	9.75	10.99	12.22	13.43	16.42						
<b>23</b>	0.95	1.77	2.56	3.31	4.05	4.77	5.48	6.18	6.87	7.55	8.90	10.22	11.53	12.82	14.09	17.23						
<b>24</b>	1.00	1.86	2.68	3.47	4.24	4.99	5.74	6.47	7.19	7.91	9.32	10.71	12.07	13.42	14.76							
<b>25</b>	1.04	1.94	2.80	3.62	4.43	5.22	6.00	6.76	7.52	8.26	9.74	11.19	12.62	14.03	15.42							
<b>28</b>	1.18	2.19	3.16	4.09	5.01	5.90	6.78	7.64	8.50	9.34	11.01	12.64	14.26	15.85	17.43							
<b>30</b>	1.27	2.36	3.41	4.41	5.39	6.35	7.30	8.23	9.15	10.06	11.86	13.62	15.36	17.08								
<b>32</b>	1.36	2.53	3.65	4.73	5.78	6.81	7.83	8.83	9.81	10.79	12.71	14.61	16.47	18.31								
<b>35</b>	1.50	2.79	4.02	5.21	6.37	7.51	8.62	9.72	10.81	11.89	14.01	16.09	18.14									
<b>40</b>	1.73	3.23	4.65	6.02	7.36	8.67	9.96	11.23	12.49	13.73	16.18	18.59										

Note: The drive performance (kilowatt ratings) of sintered bushing chains is obtained on the basis of approx. 1,000 hour endurance time.

## Applicable for many different environments

Name	Nickel Plated Chain (N)	Hi-Guard Chain (E)	Double Guard Chain (WG)
<b>Features</b>	<ul style="list-style-type: none"> <li>① Special nickel plated finish.</li> <li>② Where brilliance and cleanliness are required.</li> <li>③ Strong corrosion resistance (highly resistant to salt water spray and acid atmosphere).</li> </ul>	<ul style="list-style-type: none"> <li>① High corrosion resistant film coating.</li> <li>② Where long periods of seasonal inactivity create need for protection against indoor or out.</li> <li>③ Outstanding resistance to rusting or corrosion, particularly in salt water environments.</li> </ul>	<ul style="list-style-type: none"> <li>① Rust protection "twice as tough" as DID Hi-Guard Chain.</li> <li>② Amazing performance in acidic and alkaline atmospheres.</li> <li>③ The tensile strength and working load is the same as ANSI standard chain and makes the downsizing possible where stainless steel chain is used.</li> </ul>
<b>Functions</b>			
<b>Main uses</b>			

### ■ Environment Resistant Series: Chain No. and Codes

Chain No.	Nickel Plated	Hi-Guard	Double Guard	Stainless steel			Low temperature
				Non O-Ring		X-Ring	
<b>DID 25</b>	<b>N</b>	-	-	<b>SS</b>	-	-	-
<b>DID 35</b>	<b>N</b>	<b>E</b>	-	<b>SS</b>	-	-	-
<b>DID 41</b>	<b>N</b>	-	-	-	-	-	-
<b>DID 40</b>	<b>N</b>	<b>E</b>	<b>WG</b>	<b>SS</b>	<b>SSK</b>	<b>SSLT</b>	<b>TK</b>
<b>DID 50</b>	<b>N</b>	<b>E</b>	<b>WG</b>	<b>SS</b>	<b>SSK</b>	<b>SSLT</b>	<b>TK</b>
<b>DID 60</b>	<b>N</b>	<b>E</b>	<b>WG</b>	<b>SS</b>	<b>SSK</b>	<b>SSLT</b>	<b>TK</b>
<b>DID 80</b>	<b>N</b>	<b>E</b>	<b>WG</b>	<b>SS</b>	<b>SSK</b>	<b>SSLT</b>	<b>TK</b>
<b>DID 100</b>	<b>N</b>	<b>E</b>	-	<b>SS</b>	<b>SSK</b>	-	<b>TK</b>
<b>DID 120</b>	<b>N</b>	<b>E</b>	-	<b>SS</b>	<b>SSK</b>	-	<b>TK</b>
<b>DID 140</b>	<b>N</b>	-	-	<b>SS</b>	-	-	<b>TK</b>
<b>DID 160</b>	<b>N</b>	-	-	<b>SS</b>	-	-	<b>TK</b>
<b>DID 180</b>	-	-	-	-	-	-	-
<b>DID 200</b>	-	-	-	<b>SS</b>	-	-	-
<b>DID 240</b>	-	-	-	-	-	-	-

Stainless Steel Chain		Stainless Steel X-Ring Chain (SSLT)	Low Temperature (TK)	Name
(SS)	(SSK)			
<p>① SUS304</p> <p>② Where chains is exposed to chemicals, water and high temperature.</p> <p>③ The best resistance to corrosion and heat.</p>		<p>① Up to 10 times greater wear resistance performance compared to standard stainless steel chain.</p> <p>② Great cost saving can be achieved through longer life and less down time.</p> <p>③ The patented X-ring design provides great sealing performance at half the friction of standard O-ring.</p>	<p>① Chain is made of special alloy steel lubricated with a special grease, both ideally suited for cold temperature operation.</p> <p>② Where temperature reaches to -40 degree C. (-40 degree F.)</p> <p>③ Excellent strength and operation at low temperatures.</p>	Features
				Functions
				Main uses

## ■ Symbols

Functions	Resistant against corrosive gas (by CASS test)	Resistant against rain, moisture or sea water	Resistant against alkali liquid	Resistant against acid liquid
	Suitable for circumstances required hygiene	Allowable ambient temperature	Coating tolerable temperature	Allowable tension index (Compared to standard roller chains)
	Resistant against contaminated or deteriorated oil	No lubrication or maintenance	Resistant against dusty circumstances	Running cost and maintenance cost can be saved
Main uses	Feed and drive in packaging machines	Feed and drive in textile machines	Feed and drive in the conveyors and transfer equipment	Feed and drive in food processing machines
	Feed and drive in chemicals facilities	Feed and drive in printing machines	Feed and drive in multilevel parking machines	Feed and drive in water treatment equipment
	Feed and drive in outdoor equipment	Feed and drive in construction machines	Feed and drive in medical facilities	※1. Consult us when you use chains for hoisting. ※2. Consult us when you use chains for these particular uses.

## Nickel Plated Chain (N)



### Specialized nickel plating for a neat and clean appearance and corrosion resistance

The surface of Rustless Chains is nickel plated for an appealing exterior and corrosion resistance. It will exhibit excellent corrosion resistance especially when used in combination with grease lubrication. You can expect the effect to delay hydrogen brittle destruction when used in circumstances where chains are exposed to sea breeze or acidic sprays.

#### Features

- The chain is protected even when in use with gilding or alumite machines that emit corrosive steam. The effectiveness of rust resistance and corrosion resistance of the nickel plating does not deteriorate even under conditions of high temperature and continues to protect the chain.
- The chain's fine exterior makes it ideal for machines for demonstration.

#### Recommended uses

- When a clean appearance is preferable  
Food sanitation machines, office machines, textile machines, printing machines, pulp processing machines etc.
- When using in a corrosive environment  
Chemical machines, gilding machines, alumite machines
- When a neat exterior is necessary  
Demonstration machines at exhibitions etc.

#### Results of CASS test

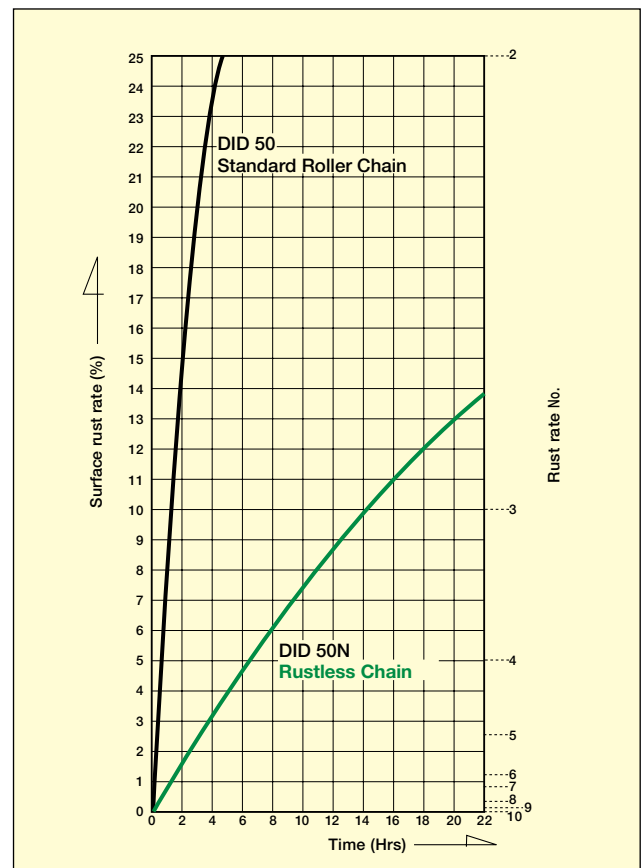

(Tested by DAIDO)



## Selection of chains

The strength of Rustless Chain is equivalent with standard roller chains. For chain selection, refer to P120-122.

## Connecting links and offset links

R connecting links are used for Rustless Chains #60 or smaller and C connecting links for #80 or larger. We provide 2POJ offset links for sizes #25 and #35, and OJ and 2POJ for all other sizes.

## Sprockets

Standard sprockets for Rustless Chains can be used since the dimensions are the same as standard roller chains.

## Caution

- ① Please use stainless steel chains when the chains are to be constantly exposed to water, sea water, liquid solutions or corrosive solutions.
- ② Unless wot so specified by the customer, chains are coated with grease before delivery. Please use the recommended lubricant (p.132) for the maintenance of the chain since lubrication using grease can cause lubrication failure.
- ③ Consult us if the chain is to be used for hoisting applications.

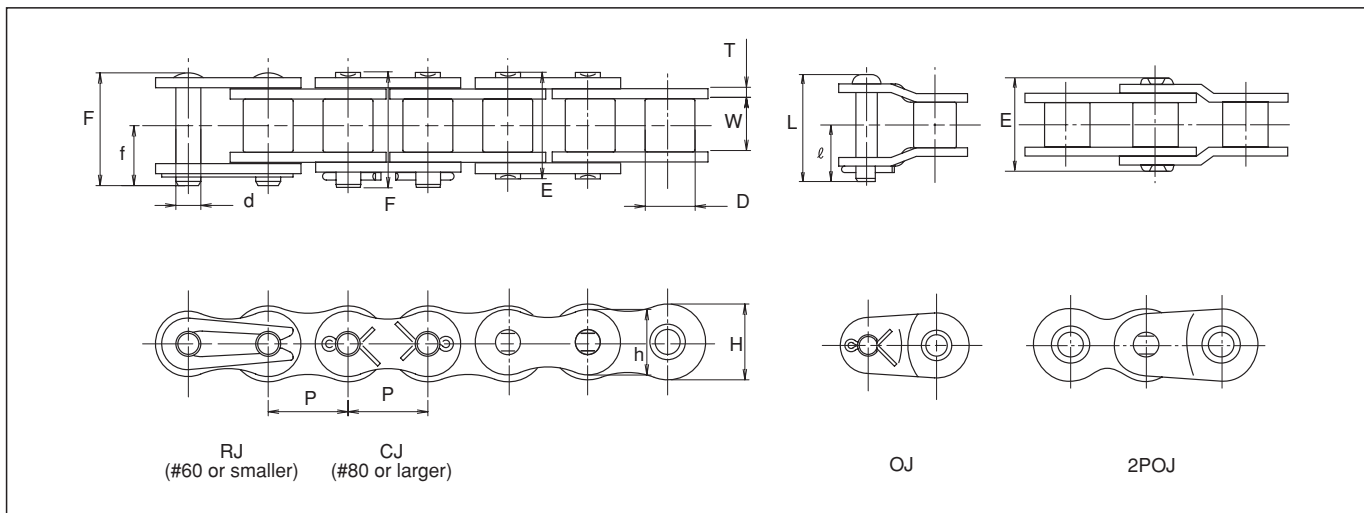

## Dimensions

Unit (mm)

Chain No.	Pitch <b>P</b>	Roller link width <b>W</b>	Roller (Bush) dia. <b>D</b>	Pin						Plate			Avg. tensile strength		Max. allowable load		Approx. weight (kg/m)
				<b>d</b>	<b>E</b>	<b>F</b>	<b>f</b>	<b>L</b>	<b>ℓ</b>	<b>T</b>	<b>H</b>	<b>h</b>	kN	kgf	kN	kgf	
* <b>DID 25N</b>	6.35	3.18	(3.30)	2.31	7.8	8.5	4.7	—	—	0.72	5.9	5.20	4.41	450	0.73	75	0.13
* <b>DID 35N</b>	9.525	4.78	(5.08)	3.59	12.0	13.1	7.3	13.9	7.8	1.25	9.0	7.75	11.2	1,150	2.15	220	0.32
<b>DID 41N</b>	12.70	6.38	7.77	3.59	13.7	14.6	7.9	15.3	8.6	1.20	9.6	8.00	10.7	1,100	2.35	240	0.39
<b>DID 40N</b>	12.70	7.95	7.92	3.97	16.5	17.6	9.5	19.3	10.6	1.50	12.0	10.40	19.1	1,950	3.72	380	0.63
<b>DID 50N</b>	15.875	9.53	10.16	5.09	20.3	21.9	11.6	23.1	12.1	2.00	15.0	13.00	30.9	3,150	6.86	700	1.06
<b>DID 60N</b>	19.05	12.70	11.91	5.96	25.4	26.9	14.3	30.0	15.7	2.40	18.1	15.60	44.1	4,500	9.31	950	1.44
<b>DID 80N</b>	25.40	15.88	15.88	7.94	32.6	35.4	19.0	36.4	19.5	3.20	24.0	20.80	78.4	8,000	14.7	1,500	2.55
<b>DID 100N</b>	31.75	19.05	19.05	9.54	39.5	42.5	22.8	43.5	23.5	4.00	29.9	26.00	118	12,100	22.5	2,300	3.79
<b>DID 120N</b>	38.10	25.40	22.23	11.11	49.7	53.0	28.2	54.1	28.2	4.80	35.9	31.20	166	17,000	30.4	3,100	5.49
<b>DID 140N</b>	44.45	25.40	25.40	12.71	53.6	58.4	31.6	59.6	31.7	5.60	41.9	36.30	215	22,000	40.2	4,100	7.11
<b>DID 160N</b>	50.80	31.75	28.58	14.29	63.6	68.2	36.4	69.7	36.5	6.40	47.8	41.40	269	27,500	52.9	5,400	9.82

Note: Those marked with \* indicate bushing chains.



## Hi-Guard Chain (E)

Roller Chains for  
Power Transmission

Environment  
Resistant  
Chain Series



## Highly protective coating that goes far beyond the performance of nickel plating

Hi-Guard Chain has higher corrosion resistance next to stainless steel chains. The surface of the chain is finished in non-gloss white highly protective coating. It has superb resistance to anti-corrosion and rusting. It has equal strength to standard roller chains, and can be used in circumstances where strength higher than that of stainless steel chains is required.

### Features

- Since high guard coating acts as a sacrificial anode for the chain body, you can expect sufficient corrosion resistance even when the coating has come off to some extent.
- The coating consists of environmentally friendly chromium free material. To comply with the EU's Restriction of Hazardous Substances (RoHS) Directive, hexavalent chromium is not used.

### Recommended uses

- Applications require both strength and corrosion resistance  
Multilevel parking facility, moving decks, cleansing lines etc.
- Conditions exposed to rain or sea water  
Machines installed outside, amusement machines



### Wear resistance

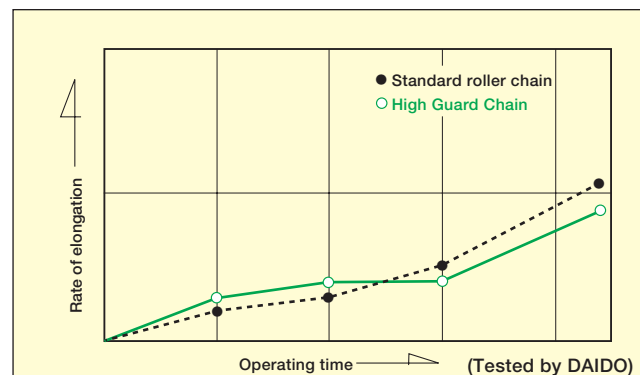





## Selection of chains

High Guard Chain has strength equivalent to standard roller chain. Refer to p.120~122 for chain selection.

## Connecting links and offset links

R connecting links are used for High Guard Chains #60 or smaller and C connecting links for #80 or larger. 2POJ offset links can be used for sizes #25 and #35, and OJ and 2POJ for all other sizes.

## Sprockets

Standard sprockets for High Guard Chains can be used since their dimensions are the same as those of standard roller chains.

## Caution

- ① Use stainless steel chains if the chains come in direct contact with food.
- ② High Guard Chain does not have a gloss like the plated chain.
- ③ High-guard coating has superb general corrosion resistance, but has poor alkaline and acidic resistance.
- ④ Unless not so specified by the customer, chains are coated with grease before delivery. If possible, lubricate the spaces between pins and bushings and rollers. Please use the recommended lubricant (p.132) for the maintenance of the chain since lubrication using grease can cause flexion failure.

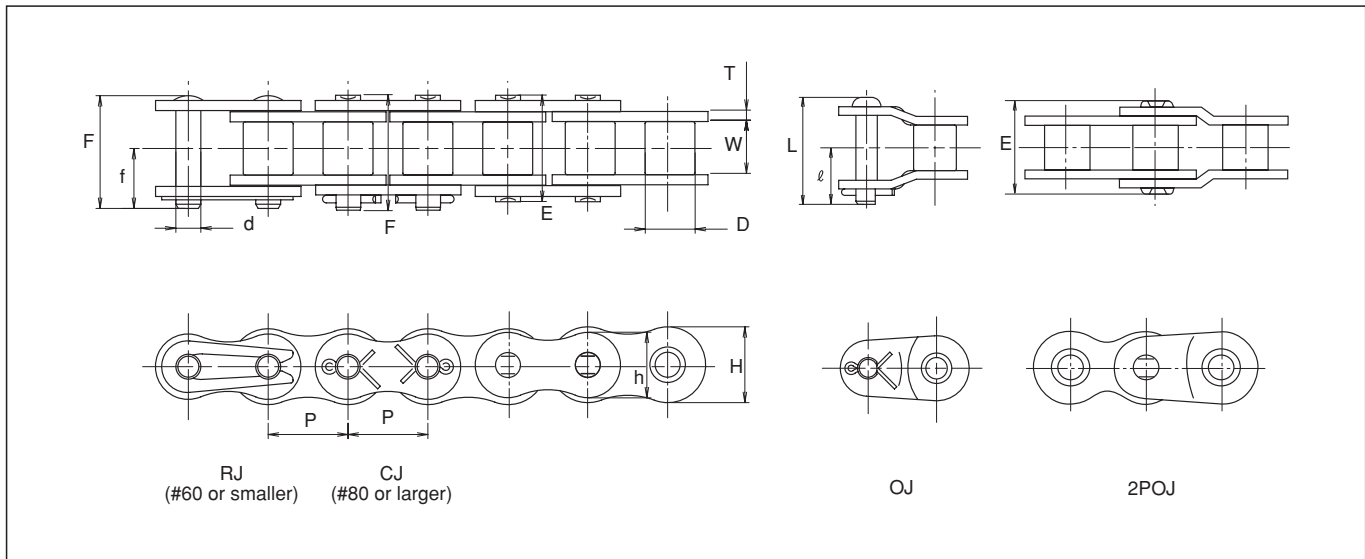

## Dimensions

Unit (mm)

Chain No.	Pitch <b>P</b>	Roller link width <b>W</b>	Roller (Bush) dia. <b>D</b>	Pin						Plate			Avg. tensile strength		Max. allowable load		Approx. weight (kg/m)
				<b>d</b>	<b>E</b>	<b>F</b>	<b>f</b>	<b>L</b>	<b>ℓ</b>	<b>T</b>	<b>H</b>	<b>h</b>	kN	kgf	kN	kgf	
* <b>DID 35E</b>	9.525	4.78	(5.08)	3.59	12.0	13.1	7.3	13.9	7.8	1.25	9.0	7.75	10.2	1,050	2.15	220	0.32
<b>DID 40E</b>	12.70	7.95	7.92	3.97	16.5	17.6	9.5	19.3	10.6	1.50	12.0	10.40	16.6	1,700	3.72	380	0.63
<b>DID 50E</b>	15.875	9.53	10.16	5.09	20.3	21.9	11.6	23.1	12.1	2.00	15.0	13.00	28.4	2,900	6.86	700	1.06
<b>DID 60E</b>	19.05	12.70	11.91	5.96	25.4	26.9	14.3	30.0	15.7	2.40	18.1	15.60	40.2	4,100	9.31	950	1.44
<b>DID 80E</b>	25.40	15.88	15.88	7.94	32.6	35.4	19.0	37.1	19.5	3.20	24.0	20.80	75.0	7,650	14.7	1,500	2.55
<b>DID 100E</b>	31.75	19.05	19.05	9.54	39.5	42.5	22.8	45.3	23.5	4.00	29.9	26.00	112.0	11,500	22.5	2,300	3.79
<b>DID 120E</b>	38.10	25.40	22.23	11.11	49.7	53.0	28.2	54.1	28.2	4.80	35.9	31.20	157.0	16,100	30.4	3,100	5.49

Note: 1. Those marked with \* indicate bushing chains.

2. Consult us for sizes not included in the chart or multiplex chains.

3. Ask us for the delivery time. Also, consult us for High Guard Chains not included in the chart.

## Double Guard Chain (WG)



### Steel chain approaching stainless steel chain in corrosion resistance

Double Guard Chain is highly corrosion resistant with coating of double layers of two different materials. Compared to the High-Guard Chain, it exhibits nearly doubled corrosion resistance in the salt water spray test, and can be used in mild alkaline and mild acidic conditions.

#### Features

- With its improved corrosion resistance, it can be used in circumstances where High-Guard or Rustless Chains cannot be used, and even in some conditions where only stainless steel can be used.
- The coating consists of environmentally friendly non-chrome material. To comply with the EU's Restriction of Hazardous Substances (RoHS) Directive, hexavalent chromium is not used.

#### Recommended uses

- Conditions that require both strength and corrosion resistance  
Multilevel parking facility, moving decks, cleansing lines etc.
- Conditions exposed to rain or sea water  
Machines installed outside, amusement machines
- Conditions exposed to mild alkaline and mild acidic chemical agents, sea water or wastewater. Various chemical plants and water treatment plants.

#### Surface conditions after corrosion test

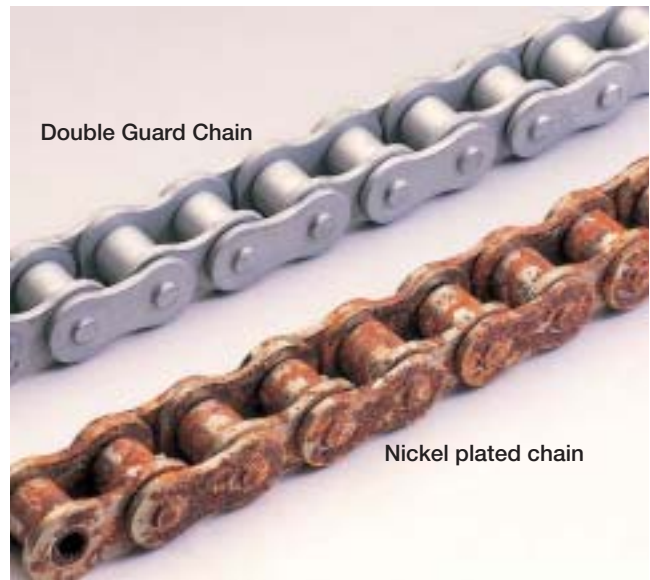

CASS test - Double Guard Chain: 60Hr, Nickel plated chain:

**Performance Comparison** Consult us about the selection of chains depending on your circumstances.

Name	Code	Strength Maximum allowance tension rate	Corrosive resistance			
			General atmosphere (Results of CASS test)	Conditions exposed to water or salt water	Alkaline resistance	Acidic resistance
Double-Guard	WG	100%	◎ (Double of High-Guard)	◎ (Double of High-Guard)	○ (No alkaline resistance)	△ Resistant to mild acidity (up to PH3)
Hi-Guard	E	100%	○	○	△	×
Standard	—	100%	△	× (Rusting)	△	× (Cracking)
Nickel plated	N	100%	○	△	○	△
Stainless steel	SS	10%	◎	◎	◎	◎

Note: ◎: Excellent, ○: Very good, △: Good, ×: No good



## Selection of chains

Double Guard Chain has an equivalent strength to a standard roller chain. Please refer to p120~122 for chain selection.

## Connecting links and offset links

R connecting links are used for high-guard chains #60 or smaller and C connecting links for #80 or larger, and OJ and 2POJ are used as offset links.

## Sprockets

Standard sprockets for high-guard chains can be used since the dimensions are the same as standard roller chains.

## Caution

- ① Use stainless steel chains if the chains will come in direct contact with food.
- ② Double Guard chain does not have a gloss like the nickel coated chain.
- ③ Unless not so specified by the customer, chains are coated with grease and shipped. If possible, oil the spaces between pins and bushes and bushes and rollers. Please use the recommended lubrication oil (P132) for the maintenance of the chain as oiling with grease can cause flexion failure.

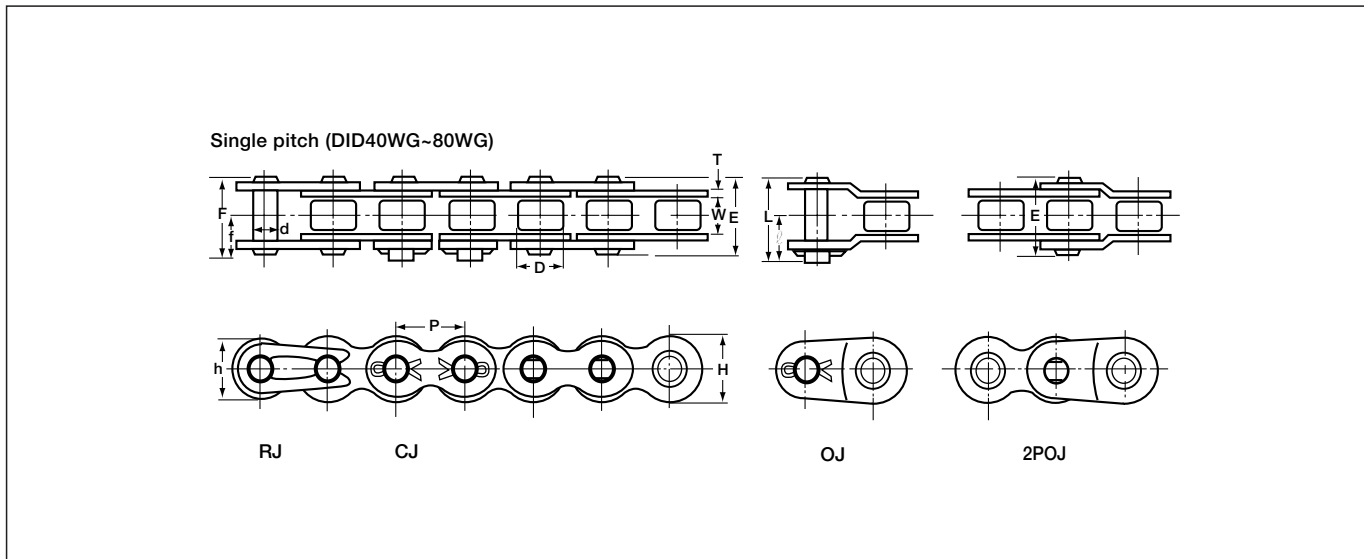

## Dimensions

Unit (mm)

Chain No.	Pitch <b>P</b>	Roller link width <b>W</b>	Roller (Bush) dia. <b>D</b>	Pin						Plate			Avg. tensile strength		Max. allowable load		Approx. weight (kg/m)
				<b>d</b>	<b>E</b>	<b>F</b>	<b>f</b>	<b>L</b>	<b>l</b>	<b>T</b>	<b>H</b>	<b>h</b>	kN	kgf	kN	kgf	
<b>DID 40WG</b>	12.70	7.95	7.92	3.97	16.5	17.6	9.5	19.3	10.6	1.50	12.0	10.40	16.6	1,700	3.72	380	0.63
<b>DID 50WG</b>	15.875	9.53	10.16	5.09	20.3	21.9	11.6	23.1	12.1	2.00	15.0	13.00	28.4	2,900	6.86	700	1.06
<b>DID 60WG</b>	19.05	12.70	11.91	5.96	25.4	26.9	14.3	30.0	15.7	2.40	18.1	15.60	40.2	4,100	9.31	950	1.44
<b>DID 80WG</b>	25.40	15.88	15.88	7.94	32.6	35.4	19.0	37.1	19.5	3.20	24.0	20.80	75.0	7,650	14.70	1,500	2.55

Note: Ask us for the delivery time

## Stainless Steel Chain (SS/SSK)



### Excellent resistance to corrosion and heat that allows use in almost everywhere

There are two types of Stainless Steel Chain: SS and SSK. The SS type has the highest resistance to corrosion and heat. However, it is made entirely of austenite stainless steel and thus its tensile strength is slightly lower than 70% of a standard roller chain, and maximum allowable load drops to a little over 10%.

By using precipitation hardened stainless steel for the pins, bushes and rollers, the SSK type has 1.5 times higher maximum allowable load compared to the SS type. Select SSK when you need more strength than SS, or desire longer product life.

Both types have equivalent corrosion resistance.

#### Recommended uses

- Conditions exposed to mild alkaline and mild acidic chemical agents, sea water and wastewater. Various chemical plants and water treatment plants.
- Conditions of high temperature  
Heat-treating furnaces, dry furnaces, incinerators

#### Maximum allowable load (Double pitch)

	Maximum allowable load			
	SS		SSK	
	kN	kgf	kN	kgf
<b>DID C2040</b> <b>DID C2042</b>	0.44	45	0.686	70
<b>DID C2050</b> <b>DID C2052</b>	0.68	70	1.03	105
<b>DID C2060H</b> <b>DID C2062H</b>	1.03	105	1.57	160

#### Average tensile strength and maximum allowable load (Single pitch)

##### SS

Chain No.	Average tensile strength		Maximum allowable load	
	kN	kgf	kN	kgf
* <b>DID 25SS</b>	3.33	340	0.117	12
* <b>DID 35SS</b>	7.55	770	0.264	27
<b>DID 40SS</b>	13.3	1,360	0.441	45
<b>DID 50SS</b>	20.9	2,130	0.686	70
<b>DID 60SS</b>	30.0	3,060	1.07	110
<b>DID 80SS</b>	53.4	5,450	1.76	180
<b>DID 100SS</b>	82.3	8,390	2.54	260

Note: Those marked with \* indicate bushing chains.

##### SSK

Chain No.	Average tensile strength		Maximum allowable load	
	kN	kgf	kN	kgf
<b>DID 40SSK</b>	13.3	1,360	0.686	70
<b>DID 50SSK</b>	20.9	2,130	1.03	105
<b>DID 60SSK</b>	30.0	3,060	1.57	160
<b>DID 80SSK</b>	53.4	5,450	2.65	270
<b>DID 100SSK</b>	82.3	8,390	3.82	390



### Selection of chains

Stainless Steel Chain has lower average tensile strength and maximum allowable load compared to the standard roller chain. Please refer to the maximum allowable load chart in the previous page and p120~122 for chain selection.

### Connecting links and offset links

R connecting links are used for Stainless Steel Chains #60 or smaller and C connecting links for #80 or larger. 2POJ offset links are used for sizes #25, and OJ links for all other sizes.

### Sprockets

Standard sprockets for Stainless Steel chains can be used since the dimensions are the same as standard roller chains.

### Caution

- ①As a general property of stainless steel, stress corrosion cracking and pitting corrosion can be caused by chlorine and chlorine ion (Cl<sup>-</sup>).
- ②The chart on right shows the data of tests on the level of corrosion resistance for each medium and does not guarantee the performance of the chains. Please take into consideration the conditions, temperature, level and other overall situation when using.

### Dimensional Drawing

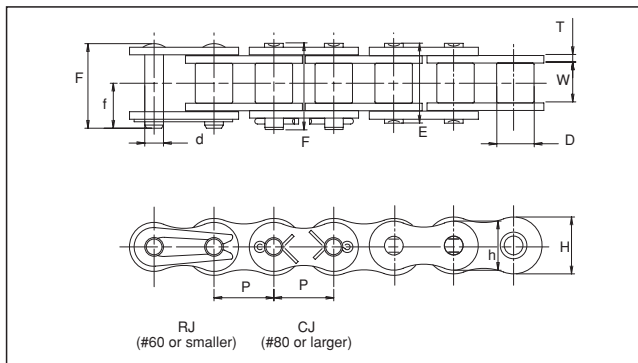

### Corrosion resistance

Medium	Standard	Stainless steel
Aceton	×	○
Sulfurous gas (wet)	×	○
Sulfurous gas (dry)	—	○
Ammonia gas (cool)	—	○
Ammonia gas (hot)	×	×
Ammonia water	△	○
Ethanol	○	○
Sodium chloride, salt	×	△
Hydrochloric acid	×	×
Chlorine gas (wet)	×	×
Sea water	×	△
Hydrogen peroxide	×	△
Caustic soda (20%)	×	○
Gasoline	○	○
Potassium permanganate	△	○
Formic acid	×	×
Milk	○	○
Citric acid	×	○
Glycerin	△	○
Acetic acid (10%)	×	○
Bleaching powder, sodium hypochlorite	×	×
Carbon tetrachloride (dry)	△	△
Alcoholic soap	×	△
Oxalic acid (5%)	×	△
Oxalic acid (10%, boiled)	×	×
Nitric acid	×	○
Vinegar	×	△
Calcium hypochlorite	×	×
Baking soda	○	○
Water	×	○
Calcium hydroxide	△	○
Phenic acid, Phenol	×	△
Petroleum	○	○
Soapwater	△	○
Carbonic water	○	○
Sodium carbonate	○	○
Kerosene	○	○
Lactic acid (5%)	×	○
Lactic acid (10%, 65°C)	×	△
Paraffin	○	○
Beer	○	○
Benzene, benzol	○	○
Boric acid (5%)	×	○
Pottasium alum	×	△
Methanol	○	○
Iodine	×	×
Butyric acid	×	△
Sulfuric acid	×	×
Phosphoric acid (10%)	×	△
Sodium sulfate (5%)	△	○
Wine	○	○

Note: 1. ○:Corrosion resistant  
 △:Corrosion resistant depending on conditions  
 ×: No resistance  
 2. Unless specified, tests were conducted at 20°C.

### Dimensions

Chain No.	Pitch P	Roller link width W	Roller (Bush) dia. D	Pin				Plate			Approx. weight (kg/m)
				d	E	F	f	T	H	h	
* DID 25SS	6.35	3.10	(3.30)	2.30	7.60	—	—	0.75	6.0	5.2	0.13
* DID 35SS	9.525	4.68	(5.08)	3.58	11.80	13.20	7.15	1.27	9.0	7.8	0.34
DID 40SS 40SSK	12.70	7.85	7.95	3.96	16.30	17.50	9.35	1.5	12.0	10.4	0.64
DID 50SS 50SSK	15.875	9.40	10.16	5.08	20.50	21.60	11.35	2.0	15.0	13.0	1.06
DID 60SS 60SSK	19.05	12.57	11.91	5.95	25.85	27.00	14.10	2.4	18.1	15.6	1.56
DID 80SS 80SSK	25.40	15.75	15.88	7.93	32.50	34.70	18.45	3.2	24.1	20.8	2.62
DID 100SS 100SSK	31.75	18.90	19.05	9.53	40.30	42.35	22.20	4.0	30.1	26.0	4.13

Note: Those marked with \* indicate bushing chains.



## Stainless Steel X-Ring Chain

Roller Chains for Power Transmission

Environment Resistant Chain Series



**Stainless Steel Chains with the features of environment resistant and wear resistant chain series. With the use of X-rings, durability improved remarkably.**

X rings were added to the Stainless Steel Chain (SS) that has the best resistance to corrosion and heat. Compared to the conventional Stainless Steel Chain, this chain has about 5-10 times resistance to abrasion. This improvement makes possible a large reduction in the running and maintenance costs.

### Recommended uses

- Conditions continuously exposed to chemical agents, sea water and wastewater.  
Various chemical plants, water treatment plants
- Conditions of high temperature  
Heat-treating furnaces, dry furnaces, incinerators

The grease and seal rings meet the standards of the Food Sanitation Law.  
Consult us about the environmental conditions and chain selection.

### Wear resistance of Stainless Steel Chain

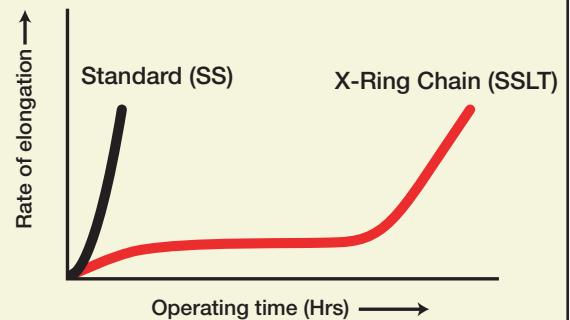

### Friction chart

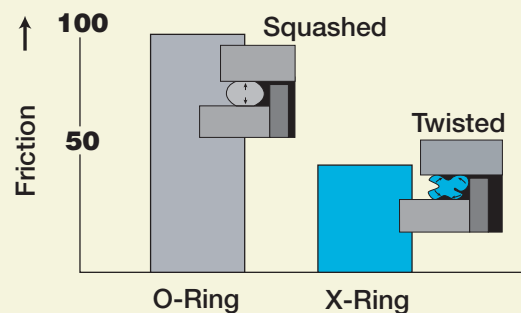



## Selection of chains

The average tensile strength and maximum allowable load of the Stainless Steel Chain are both lower than a standard roller chain. Refer to the maximum allowable load for the selection of chains.

## Connecting links

R connecting links are used for Stainless Steel Chains #60 or smaller and C connecting links for #80 or larger.

## Sprockets

The pins for the X-Ring chains are longer than those of standard roller chains, and thus standard sprockets for multiplex chain cannot be used for the X-Ring chains when using this chain in multiplex.

## Caution

- As a general property of stainless steel, stress corrosion cracking and pitting corrosion can be caused by chlorine and chlorine ion (Cl<sup>-</sup>).
- The chart on right shows the data of tests on the level of corrosion resistance for each medium and does not guarantee the performance of the chains. Please take into consideration the conditions, temperature, level and other overall situation when using.

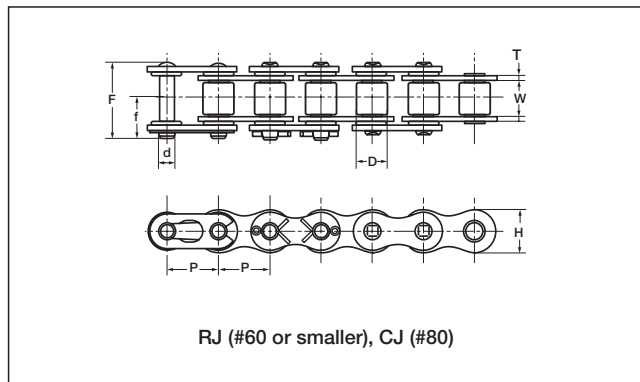

## Corrosion resistance

Medium	Standard	Stainless steel
Aceton	×	○
Sulfurous gas (wet)	×	○
Sulfurous gas (dry)	—	○
Ammonia gas (cool)	—	○
Ammonia gas (hot)	×	×
Ammonia water	△	○
Ethanol	○	○
Sodium chloride, salt	×	△
Hydrochloric acid	×	×
Chlorine gas (wet)	×	×
Sea water	×	△
Hydrogen peroxide	×	△
Caustic soda (20%)	×	○
Gasoline	○	○
Potassium permanganate	△	○
Formic acid	×	×
Milk	○	○
Citric acid	×	○
Glycerin	△	○
Acetic acid (10%)	×	○
Bleaching powder, sodium hypochlorite	×	×
Carbon tetrachloride (dry)	△	△
Alcoholic soap	×	△
Oxalic acid (5%)	×	△
Oxalic acid (10%, boiled)	×	×
Nitric acid	×	○
Vinegar	×	△
Calcium hypochlorite	×	×
Baking soda	○	○
Water	×	○
Calcium hydroxide	△	○
Phenic acid, Phenol	×	△
Petroleum	○	○
Soapwater	△	○
Carbonic water	○	○
Sodium carbonate	○	○
Kerosene	○	○
Lactic acid (5%)	×	○
Lactic acid (10%, 65°C)	×	△
Paraffin	○	○
Beer	○	○
Benzene, benzol	○	○
Boric acid (5%)	×	○
Pottasium alum	×	△
Methanol	○	○
Iodine	×	×
Butyric acid	×	△
Sulfuric acid	×	×
Phosphoric acid (10%)	×	△
Sodium sulfate (5%)	△	○
Wine	○	○

Note: 1. ○:Corrosion resistant  
 △:Corrosion resistant depending on conditions  
 ×: No resistance  
 2. Unless specified, tests were conducted at 20°C.

## Dimensions

Chain No.	Pitch P	Roller link width W	Roller (Bush) dia. D	Pin			Plate		Avg. tensile strength		Max. allowable load		Approx. weight (kg/m)	
				d	E	f	T	H	kN	kgf	kN	kgf		
														Unit (mm)
Single Pitch Chain	<b>DID 40SSLT</b>	12.70	7.95	7.92	3.96	20.0	10.7	1.5	12.0	13.3	1,360	0.441	45	0.67
	<b>DID 50SSLT</b>	15.875	9.53	10.16	5.08	23.9	12.8	2.0	15.0	20.9	2,130	0.686	70	1.08
	<b>DID 60SSLT</b>	19.05	12.70	11.91	5.95	29.8	16.0	2.4	18.1	30.0	3,060	1.07	110	1.62
	<b>DID 80SSLT</b>	25.40	15.88	15.88	7.93	38.5	20.9	3.2	24.1	53.4	5,450	1.76	180	2.83

## Low-Temperature Resistant Chain (TK)



### Chain made of specialized material for extreme low-temperature down to -40°C.

Standard roller chains often become susceptible to brittle fracture when used in temperatures under -10°C. We recommend using this chain made of specialized material with high resistance to cold brittleness when using chains in extremely low temperatures. By setting the conditions according to the below table of maximum allowable load, the chain can be used in temperatures down to -40°C.

#### Recommended uses

- Inside freezers, conditions of high altitude or cold climates

#### Maximum allowable load

Chain No.	+80°C~ -10°C		-11°C~ -30°C		-31°C~ -40°C	
	kN	kgf	kN	kgf	kN	kgf
<b>DID 40TK</b>	3.72	380	2.54	260	2.15	220
<b>DID 50TK</b>	6.86	700	4.80	490	3.92	400
<b>DID 60TK</b>	9.31	950	6.47	660	5.39	550
<b>DID 80TK</b>	14.70	1,500	10.29	1,050	8.53	870



## Selection of chains

The maximum allowable load of Low-temperature Resistant chains differ by temperature. Please refer to the table in the previous page for chain selection. Please refer to P120~122 for other criteria. If used in normal temperature, better shock resistance can be expected compared to standard roller chains.

## Connecting links and offset links

R connecting links are used for Low-temperature Resistance chains #60 or smaller and C connecting links for #80 or larger. There are no offset links.

## Sprockets

Standard sprockets can be used for Low-temperature Resistance Chain as their dimensions are equivalent to standard roller chains.

## Caution

Please use lubrication oil for cold resistance for the maintenance of the chain.

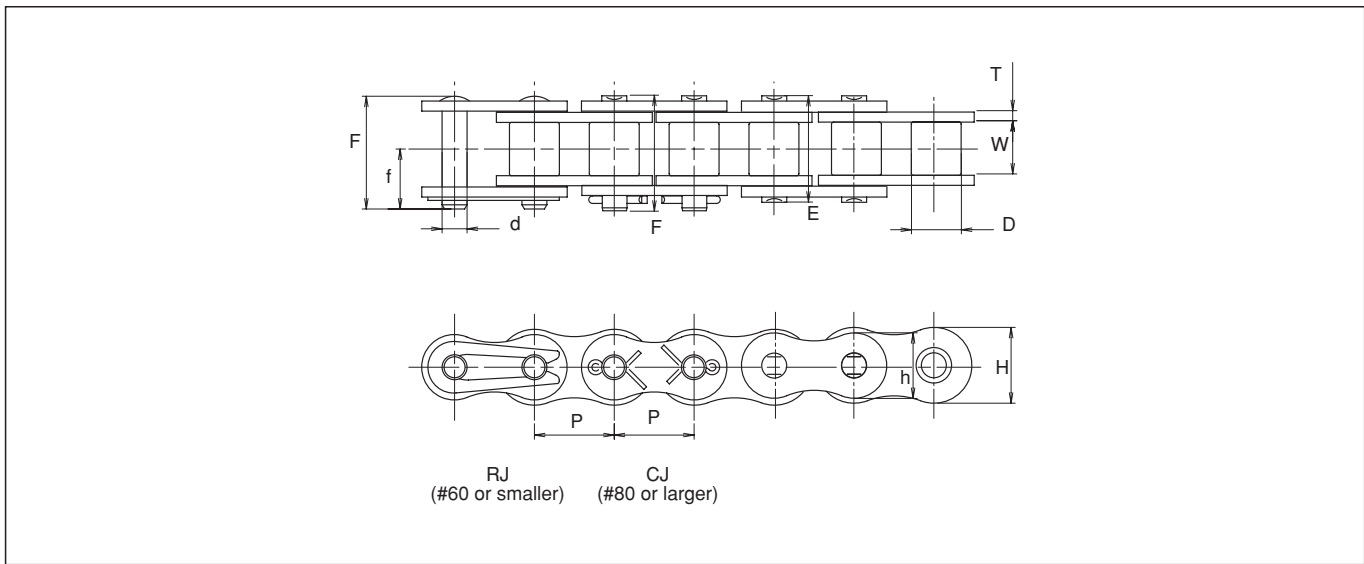

## Dimensions

Unit (mm)

Chain No.	Pitch <b>P</b>	Roller link width <b>W</b>	Roller (Bush) dia. <b>D</b>	Pin				Plate			Approx. weight (kg/m)
				<b>d</b>	<b>E</b>	<b>F</b>	<b>f</b>	<b>T</b>	<b>H</b>	<b>h</b>	
<b>DID 40TK</b>	12.70	7.95	7.92	3.97	16.5	17.6	9.5	1.50	12.0	10.4	0.63
<b>DID 50TK</b>	15.875	9.53	10.16	5.09	20.3	21.9	11.6	2.00	15.0	13.0	1.06
<b>DID 60TK</b>	19.05	12.70	11.91	5.96	25.4	26.9	14.3	2.40	18.1	15.6	1.44
<b>DID 80TK</b>	25.40	15.88	15.88	7.94	32.6	35.4	19.0	3.20	24.0	20.8	2.55

## Unparalleled noise reduction

Super Low Noise Chain (UN) has achieved a higher drive performance while having equivalent noise reduction performance to Previous Low Noise Chain (TB). By improving the drive performance to the level of standard roller chains, Low Noise Chains are now applicable to many more machines and equipment.

Roller Chains for Power Transmission  Low Noise Chain Series	<b>Super Low Noise Chain (UN)</b>
	
	<b>Name</b>
	<b>Features</b> <ul style="list-style-type: none"> <li>① Approx. 10dB noise reduction compared to a standard chain</li> <li>② Two Piece roller</li> <li>③ Equivalent durability (strength) to standard roller chains</li> </ul>
	<b>Functions</b> <div style="display: flex; align-items: center; justify-content: center; gap: 20px;"> <div style="border: 1px solid black; padding: 5px; text-align: center;">                     Max. KW Rating <b>100%</b> </div> <div style="border: 1px solid black; padding: 5px; text-align: center;">                     Noiseless <b>10dB</b> </div> <div style="font-size: small;">                         ※Noise reduction values differ by the chain sizes and conditions for use                     </div> </div>
<b>Main uses</b> <div style="display: flex; justify-content: center; gap: 10px; margin-top: 10px;"> <div style="border: 1px solid black; border-radius: 50%; padding: 5px; background-color: yellow;">PRINT</div> <div style="border: 1px solid black; border-radius: 50%; padding: 5px; background-color: yellow;">PACK</div> <div style="border: 1px solid black; border-radius: 50%; padding: 5px; background-color: yellow;">CONVEYOR</div> <div style="border: 1px solid black; border-radius: 50%; padding: 5px; background-color: yellow;">MACHINING</div> <div style="border: 1px solid black; border-radius: 50%; padding: 5px; background-color: yellow;">PARKING</div> </div>	

### ■ Table of Low Noise Series

Chain No.	Super Low Noise
<b>DID 40</b>	<b>UN</b>
<b>DID 50</b>	<b>UN</b>
<b>DID 60</b>	<b>UN</b>
<b>DID 80</b>	<b>UN</b>

# 1. Drive performance equivalent to standard chains

Max. KW Rating **100%**

Excerpt from the table of Drive Performance 40TB

No. of teeth of small sprocket	Small sprocket rpm			
	50	200	400	600
11	0.20	0.50	0.47	0.45
12	0.22	0.57	0.53	0.51
13	0.24	0.65	0.60	0.58
14	0.26	0.72	0.67	0.65

**DID 40TB**

DID 40TB  
VS  
DID 40UN  
(Unit: kW)

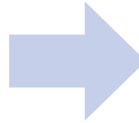

Excerpt from the table of Drive Performance 40 in the general catalog

No. of teeth of small sprocket	Small sprocket rpm			
	50	200	400	600
11	0.20	0.70	1.30	1.88
12	0.22	0.77	1.43	2.06
13	0.24	0.84	1.56	2.25
14	0.26	0.91	1.69	2.44

**Super Low Noise DID 40UN**

Set the chain speed within 210m/min.

Roller Chains for Power Transmission  
Low Noise Chain Series

# 2. Noise reduction equivalent to Previous Low Noise chains

Noiseless **10dB**

※Noise reduction value differs by the chain sizes and conditions for use

The noise emitted when the chain engages with the sprockets can be reduced by approx. 10dB. For conveyor chains, sliding noise of the rails and the rollers can be reduced as well.

# 3. Durability equivalent to standard chains

The chains exhibit durability higher than Previous Low Noise chains and at the same level as standard chains.

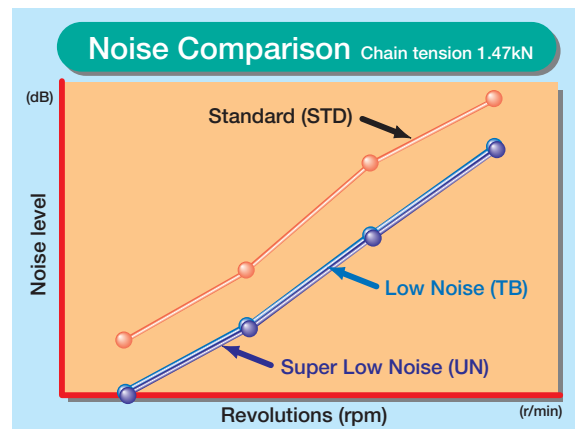

## Structures of the chains and noise reduction mechanism

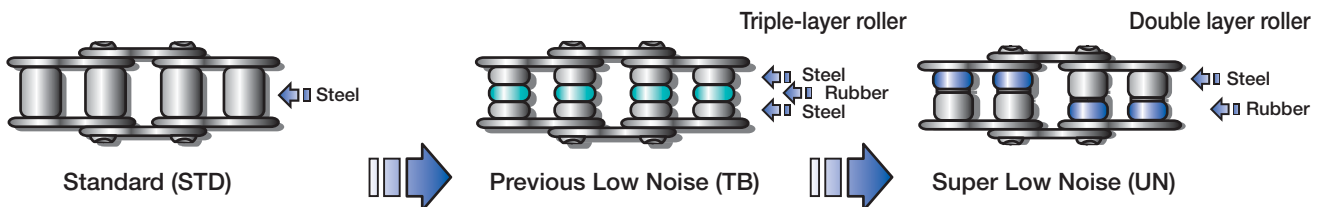

- Standard connecting links and sprockets can be used. Offset links are specialized.
- Low noise chains available in sizes DID40UN~80UN.
- Preventing partial wear of sprockets and rails

Compared to Previous Low Noise chains, the steel rollers of the Super Low Noise are in staggered assembling in the traveling direction to reduce partial wear of the sprockets and rails.

## Super Low Noise Chain (UN)



## A brand new low noise chain with unparalleled noise reduction

Super Low Noise Chain (UN) has achieved a higher drive performance while having reduced noise like Previous Low Noise Chain (TB). By improving the drive performance to the level of standard roller chains, Low Noise Chains are now applicable to many more machines and equipment.

### Noise reduction comparison

There is about 10dB noise reduction to the noise from when the chain engages with the sprockets. (Fig. below) The sliding noise from the rails and the rollers can be reduced as well.

### Features

- Super Low Noise Chain was developed in response to the needs for a wider application of low noise chains by modifying the triple-layer roller structure of the TB Chain into a double layer roller. Noise reduction level is equivalent to that of TB Chain.

### Recommended uses

- Circumstances requiring the drive performance of chains at the noise level of belt conveyors
- Printing machines, packaging machines, office appliances etc

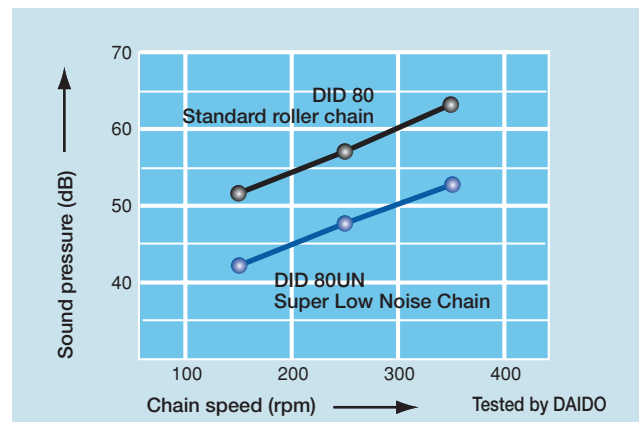

### Allowable Load of Rollers

Unit: N(kgf)/piece

Chain No.	Allowable load
<b>DID 40UN</b>	78 (8)
<b>DID 50UN</b>	117 (12)
<b>DID 60UN</b>	196 (20)
<b>DID 80UN</b>	313 (32)

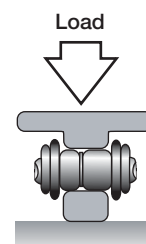



## Selection of chains

See the "Selection by max. kilowatt ratings" (P120) or "Low-speed selection" (P121) for chain selection.

Note: Set the chain speed within 210 m/min.

Super low noise chains are available up to five strands.

## Sprockets, connecting links and offset links

Standard sprockets and connecting links can be used. Offset links are also available.

It is recommended to use the sprockets with teeth of odd numbers or even numbers indivisible by four to engage them with the chain rollers.

## Caution

The rollers are made of risen and their performance deteriorates when exposed to ultraviolet (UV) rays. In addition, do not use in circumstances where the resin roller are exposed to sprays and vapors of substances listed below:

Nonflammable hydraulic oil (phosphoric esters, water-glycol fluid), oils containing extreme-pressure additives, hot water, vapor, ester, ketone, organohalogen, pure aromatic compounds, strong acid, strong basic agents, strong acidic reagents, carbon disulfide, sulfur dioxide.

The applicable conditions are equivalent to those of standard roller chains.

The corrosion resistance against water, acid, alkaline, and other chemical substances are also equivalent to that of standard roller chains.

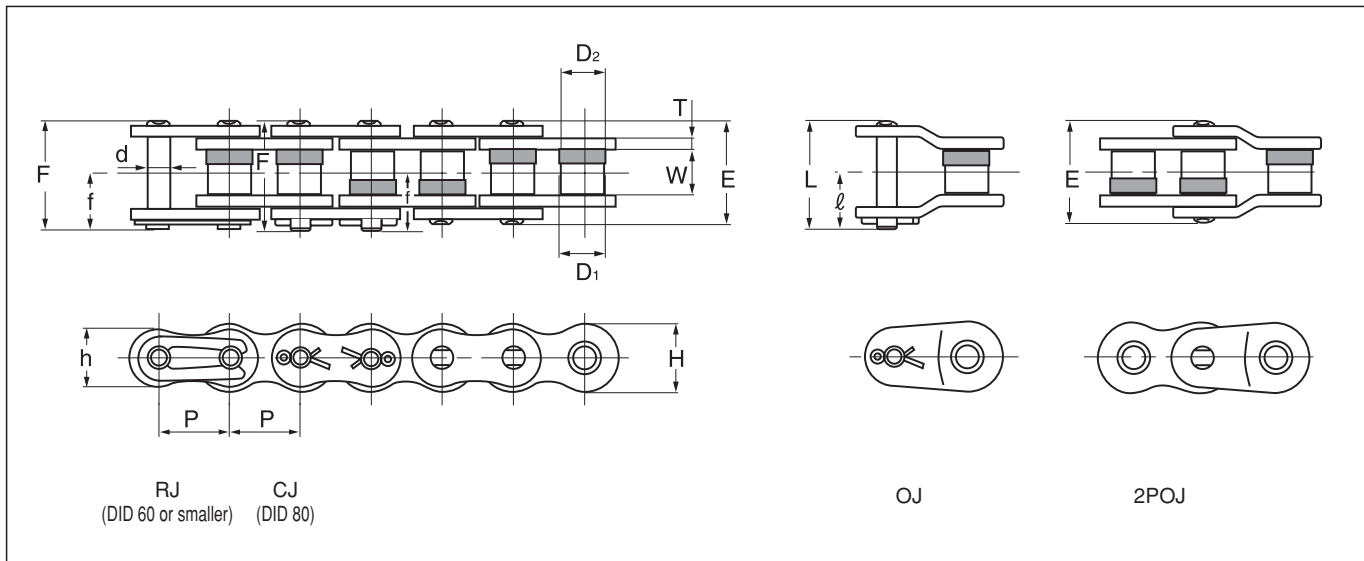

## Dimensions

Unit (mm)









Chain No.	Pitch P	Roller link width W	Roller (Bush) dia.		Pin						Plate			Avg. tensile strength		Max. allowable load		Approx. weight (kg/m)
			D <sub>1</sub>	D <sub>2</sub>	d	E	F	f	L	ℓ	T	H	h	kN	kgf	kN	kgf	
<b>DID 40UN</b>	12.70	7.95	7.72	8.15	3.97	16.5	17.6	9.5	19.3	10.6	1.50	12.0	10.4	19.1	1,950	3.72	380	0.59
<b>DID 50UN</b>	15.875	9.53	9.85	10.40	5.09	20.3	21.9	11.6	23.1	12.1	2.00	15.0	13.0	30.8	3,150	6.86	700	0.98
<b>DID 60UN</b>	19.05	12.70	11.55	12.14	5.96	25.4	26.9	14.3	30.0	15.7	2.40	18.1	15.6	44.1	4,500	9.31	950	1.43
<b>DID 80UN</b>	25.40	15.88	15.34	16.10	7.94	32.8	35.3	19.0	37.1	19.5	3.20	24.0	20.8	78.1	8,000	14.7	1,500	2.36













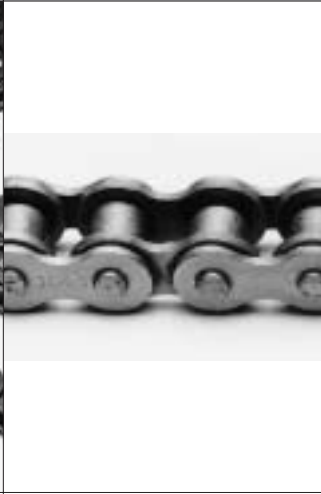

Note: 1. The values of the average tensile strength and maximum allowable tension are for the chain body.

2. Consult us for multiplex chains and other specifications.







3. Refer to the table "Allowable Load of Rollers" on P96 for an optimum sprocket.

## Responding to various kind of needs

	Bicycle Chain	Small Pitch Chain	Engine Mechanism Chain	Silent Chain SCA, SCR, SC
	Name			
Features	<ul style="list-style-type: none"> <li>① DID brand Major product</li> <li>② Rustproof treated Hi-Guard (E) available</li> <li>③ Lightest of the same size models</li> </ul>	<ul style="list-style-type: none"> <li>① Ultra-precise chain</li> <li>② 4.7625 mm pitch available</li> <li>③ For high-tech machines</li> </ul>	<ul style="list-style-type: none"> <li>① Camshaft drive timing chain</li> <li>② Drive chain of attached units (oil pumps etc)</li> <li>③ For high performance engines</li> </ul>	<ul style="list-style-type: none"> <li>① Ideal engaging structure</li> <li>② High-speed strong tensile transmission possible</li> <li>③ High noise reduction</li> </ul>
Main uses	  	 		

	Silent Chain PS	Agricultural Roller Chain	BS Roller Chain (ISO B-series roller chain)	Leaf Chain	Name
					
	<ul style="list-style-type: none"> <li>① Higher durability compared to SC</li> <li>② Larger noise reduction compared to SC</li> </ul>	<ul style="list-style-type: none"> <li>① Highly wear resistant</li> <li>② Highly heavy-load resistant</li> <li>③ Highly shock load resistant</li> </ul>	<ul style="list-style-type: none"> <li>① Complying with ISO "B series" standard</li> <li>② Complying with the British and German Standards</li> <li>③ Sprockets comply with the British Standard.</li> </ul>	<ul style="list-style-type: none"> <li>① Composed of pins and plates only.</li> <li>② Higher strength compared to roller chains</li> <li>③ Two types are available: AL and BL</li> </ul>	Features
		 	    	  	Main uses

## Symbols

Main uses	 Feed and drive in printing machines	 Feed and drive in the conveyors and transfer equipment	 Feed and drive in textile machines
	 Feed and drive in construction machines	 Feed and drive of home appliances	 Drive of agricultural machines
	 Feed and drive in packaging machines		

In addition to general chains, we also manufacture numerous chains developed for specific applications such as bicycle chains and motorcycle chains.

Some specialty chains can be engaged with standard sprockets. Wear resistant properties of general chains are included in the specifications of each type of specialty chains.

Specialty chains are classified as follows:

- **Bicycle Chain**
- **Small Pitch Chain**
- **Engine Mechanism Chain**
- **Silent Chain**
- **Agricultural Chain**
- **Leaf Chain**
- **BS type Roller Chain (British Standard Roller Chain)**

# Bicycle Chain

Bicycle chains are emblematic of the DID brand, and we were founded originally for the production of bicycle chains. They have been used in many bicycles made in Japan and worldwide countries.

Recently, our Hi Guard Chain (E) with an additional rust preventive treatment has favorable reputation by users.

The bicycle chains have been continuously examined and improved in performance, quality and specifications as seen in the availability of current products. As a result, they are the lightest and most compact chains among products of the same size. Presently, they are used not only for bicycles but for many purposes such as the driving of vending machines and agricultural implements and for conveyor systems.

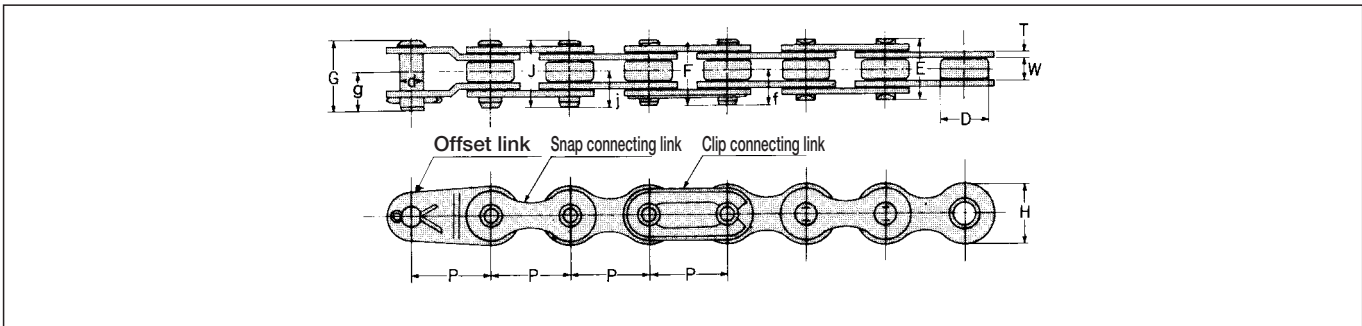

## Dimensions

Chain No.	Pitch P	Roller link width W	Roller dia. D	Pin								Plate		Guaranteed tensile strength (kN)	Avg. tensile strength		Approx. weight (kg/m)
				d	E	F	G	J	f	g	i	H	T		kN	kgf	
<b>DID</b> 1/2×1/8	12.70	3.45	7.77	3.62	9.10	10.55	11.05	11.10	6.0	6.5	6.1	9.65	1.0	8.14	9.02	920	0.271
<b>DID</b> 1/2×1/8M	12.70	3.45	7.77	3.62	9.10	10.55	11.05	11.10	6.0	6.5	6.1	9.65	1.0	8.14	9.02	920	0.271
<b>DID</b> 1/2×1/8 (E)	12.70	3.45	7.77	3.62	9.10	10.55	11.05	11.10	6.0	6.5	6.1	9.65	1.0	8.14	9.02	920	0.271
<b>DID</b> 1/2×1/8 Track racer	12.70	3.45	7.77	3.62	9.40	10.55	11.05	11.10	6.0	6.5	6.1	9.65	1.0	8.82	9.61	980	0.274
<b>DID</b> 1/2×3/16	12.70	4.80	7.77	3.62	10.75	11.95	12.30	12.15	6.7	7.2	6.8	9.65	1.0	8.14	9.02	920	0.313

Note: 1. Bolt connecting link is the standard connecting link for the track racer chain.  
 2. M and (E) models are high anti-tight type.  
 3. The values of avg. tensile strength are for chains.

## Small Pitch Chain

The smallest chain complying to ANSI is DID25 of 6.35 mm pitch. However, in response to the demands for smaller chains in recent years for high technology machinery such as office equipment, medical machines and industrial robots, we provide DID15 of 4.7625 mm (3/16 inch) pitch and also DID15H1 as a high-power version of DID15. These high precision chains are manufactured under severe quality control especially required for small sizes, taking wear resistance also into account.

**DID15:** A high precision mini-pitch bushing chain that is smaller than a compact drive chain for general applications, DID25



**DID25:** Smallest bushing chain among ANSI standard chains using curl bushings.



**DID35:** A ANSI standard bushing chain suitable for small precision machines that require high strength.



### Selection of chain

Refer to the "Low-speed selection" (P.121). However, the chain operation speed can be set considerably high depending on the type of lubrication as shown in the table below.

### Connecting links and offset links

R connecting links are used for small pitch chains. However, since their strength is lower than that of the base chain, and since the clip is likely to come off in high speed operation, the use of connecting links is not recommended. Use a loop chain without attaching connecting links.

Offset links are available for chains other than DID15 and DID15H1, but their use is not recommended for the same reason as stated for the R Connecting links.

### Operating speed and type of lubrication

	Type A Oil feeder, brush, drip	Type B Oil bath, disk	Type C Forced pump feed
<b>DID 15</b> <b>DID 15H1</b> <b>DID 25</b>	200m/min or less	1200m/min or less	Over 1200m/min
<b>DID 25H</b> <b>DID 25T</b> <b>DID 35</b>			
<b>DID 35T</b>	150	1000	
	110	850	

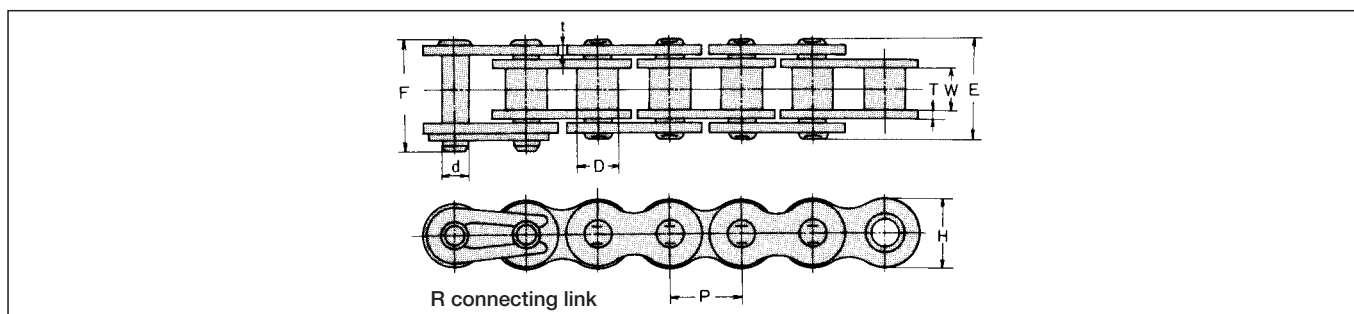

### Dimensions

Chain No.	Pitch P	Bushing		Pin		Plate		Baring area (cm <sup>2</sup> )	Avg. tensile strength		Max. allowable load		Approx. weight (kg/m)		
		Width W	Dia. D	Dia. d	Length		Thickness T		Width H	kN	kgf	kN		kgf	
					E	F									
<b>DID 15</b>	4.7625	2.40	2.48	1.62	6.25	6.90	0.60	0.60	4.30	0.060	1.96	270	0.49	50	0.089
<b>DID 15H1</b>	4.7625	3.18	2.48	1.62	7.30	—	0.72	0.72	4.30	0.789	3.14	320	0.58	60	0.103
<b>DID 25</b>	6.35	3.18	3.30	2.31	7.80	8.50	0.72	0.72	5.90	0.109	4.41	450	0.73	75	0.134
<b>DID 25H</b>	6.35	3.18	3.30	2.31	9.00	9.45	1.00	1.00	5.90	0.122	5.88	600	1.07	110	0.163
<b>DID 25T</b>	6.35	3.18	3.30	2.31	8.00	8.50	0.72	0.72	5.90	0.109	4.41	450	0.73	75	0.134
<b>DID 35</b>	9.525	4.78	5.08	3.59	12.00	13.00	1.25	1.25	9.00	0.265	11.20	1,150	2.15	220	0.332
<b>DID 35T</b>	9.525	4.78	5.08	3.59	12.00	13.00	1.25	1.25	9.00	0.265	11.20	1,150	2.15	220	0.332

Note: The values of max. allowable tension are not applied to connecting links.



# Engine Mechanism Chain

Due to the extremely high technical demands derived from the development of the automobile industry, rapid strides were made in the development of engine mechanism chains such as timing chains for driving cam shafts on 4-cycle engines used in motorcycles and motor vehicles, chains for driving oil pumps, generators and other auxiliary machines, and chains for driving balancer shafts. We have world class technical expertise in this area. The DID engine mechanism chains have excellent wear resistance, fatigue strength, silencing effect and shock strength capable of withstanding high speed operation, and can meet the conditions required for today's powerful yet down-sized high performance engines. For silent chains, see the section for silent chains in this catalog.

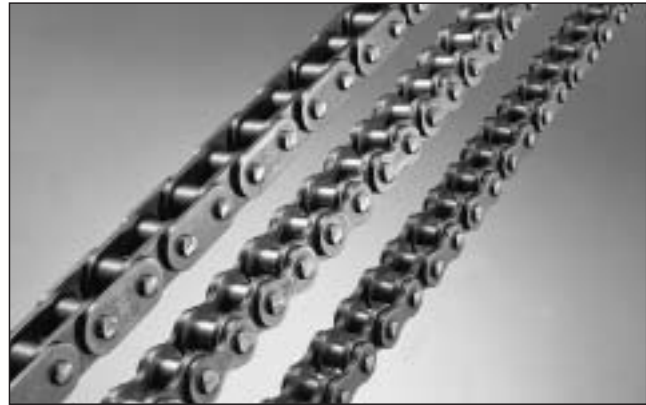

Roller Chains for Power Transmission

Speciality Chain Series

## Dimensional Drawing

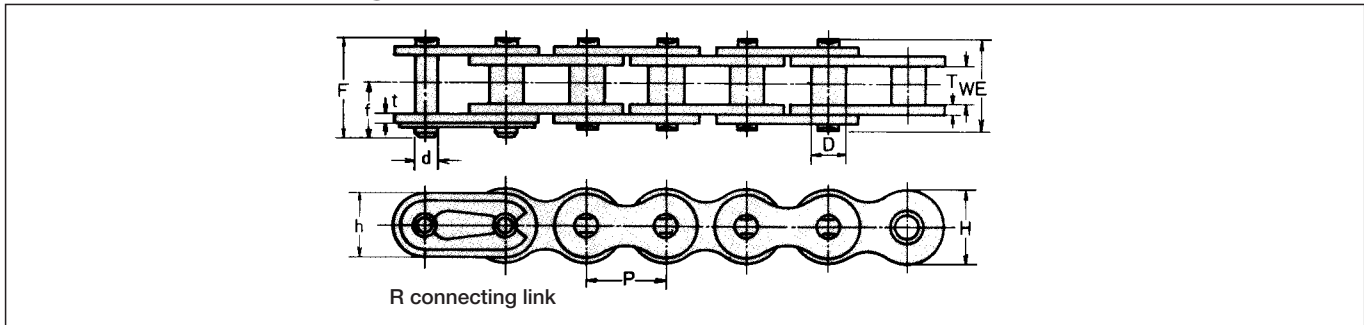

## Dimensions

Unit (mm)

Chain No.	Connecting link	Pitch P	Roller link width W	Roller dia. D	Pin				Plate				Avg. tensile strength		Max. allowable load		Approx. weight (kg/m)
					d	E	F	f	T	t	H	h	kN	kgf	kN	kgf	
<b>DID 25</b>	RJ	6.35	3.18	*3.30	2.31	7.8	8.5	4.7	0.72	0.72	5.9	5.2	4.41	450	0.73	75	0.13
<b>DID 25H</b>	RJ	6.35	3.18	*3.30	2.31	9.0	9.45	5.15	1.0	1.0	5.9	5.2	5.88	600	1.07	110	0.16
<b>DID 25SH</b>	—	6.35	3.18	*3.30	2.01	9.0	—	—	1.0	1.0	5.9	5.2	5.09	520	0.91	93	0.17
<b>DID 25SD</b>	—	6.35	3.18	*3.30	2.00	9.0	—	—	1.0	1.0	5.9	5.2	5.59	570	0.88	90	0.17
<b>DID 25-2</b>	RJ	6.35	3.18	*3.30	2.31	14.4	15.0	4.7	0.72	0.72	5.9	5.2	8.23	840	1.17	120	0.26
<b>DID 25H-2</b>	RJ	6.35	3.18	*3.30	2.29	16.6	17.2	5.15	1.0	1.0	5.9	5.2	10.79	1,100	1.76	180	0.38
<b>DID 215F DHA</b>	—	7.00	3.50	*4.00	2.51	10.15	—	—	1.2	1.0	6.7	6.7	8.14	830	1.62	165	0.26
<b>DID 219H</b>	RJ	7.774	5.00	*4.59	3.01	12.0	12.7	6.8	1.2	1.0	7.6	6.6	7.74	790	1.27	130	0.27
<b>DID 219HTM</b>	RJ	7.774	4.60	*4.59	3.01	12.15	12.9	6.9	1.4	1.3	7.6	6.5	9.80	1,000	1.76	180	0.30
※ <b>DID 219FTS DHA</b>	—	7.774	5.00	*4.59	2.61	11.85	—	—	1.2	1.0	7.6	7.6	8.92	910	1.77	180	0.31
※ <b>DID 219FTH1</b>	—	7.774	5.00	*4.59	2.62	12.3	—	—	1.2	1.2	7.6	7.6	8.92	910	2.15	220	0.33
※ <b>DID 05T DHA</b>	—	8.00	4.61	*4.71	3.01	11.5	—	—	1.3	1.0	7.8	7.8	9.61	980	2.15	220	0.33
※ <b>DID 05R SDH</b>	—	8.00	4.61	5.65	2.62	11.85	—	—	1.3	1.0	7.8	7.8	8.97	915	2.15	220	0.37
※ <b>DID 05S SDH</b>	—	8.00	4.61	5.65	3.00	12.30	—	—	1.3	1.2	7.8	7.8	12.1	1,230	3.00	305	0.40
<b>DID 270H</b>	—	8.50	4.75	*5.00	3.28	13.15	—	—	1.8	1.4	8.6	7.1	12.1	1,240	2.15	220	0.39
<b>DID 270S DHA</b>	—	8.50	4.75	*5.00	3.01	12.0	—	—	1.3	1.2	8.6	7.1	10.7	1,100	1.96	200	0.33
<b>DID 270FH DHA</b>	—	8.50	4.75	*5.00	3.28	13.15	—	—	1.8	1.4	8.6	8.6	14.7	1,500	2.45	250	0.50
※ <b>DID 06B DHA</b>	RJ	9.525	5.72	6.35	3.28	13.15	13.6	7.4	1.3	1.0	8.2	8.2	10.4	1,070	1.96	200	0.39
※ <b>DID 06BH DHA</b>	—	9.525	5.72	6.35	3.27	13.85	—	—	1.4	1.2	8.2	8.2	11.1	1,130	2.65	270	0.43
※ <b>DID 06B-2</b>	RJ	9.525	5.72	6.35	3.28	22.75	23.9	7.4	1.3	1.0	8.2	8.2	19.4	1,980	3.13	320	0.74
※ <b>DID 317FM2</b>	—	9.525	5.05	6.35	3.28	13.15	—	—	1.5	1.2	8.2	8.2	12.7	1,300	3.23	330	0.28
※ <b>DID 317FM-2</b>	—	9.525	5.05	6.35	3.27	24.7	—	—	1.5	1.2	8.2	8.2	24.3	2,480	4.90	500	0.81

- Note: 1. Those marked with \* are bushing chains, and thus the values indicate bushing diameters.
- 2. Chains marked with ※ have flat oval-shaped plates.
- 3. DH- $\alpha$  treatment (DHA) is available. Consult us for DHA types.
- 4. The values of max. allowable load are not applied to connecting links. Don't use connecting links in engines.

## Silent Chain

### SC silent chains (SCA, SCR, SC)

SC silent chains use specially-coated round pins and special plates to achieve an ideal engagement mechanism, and can keep a noise level remarkably lower than conventional roller chains.

SC type silent chains can be used for high speed and large tension transmission just like a toothed metallic belt since the plates directly engage with the sprockets for driving.

SCR-04 silent chains are designed with inner engaging structure for further reduced noise level.

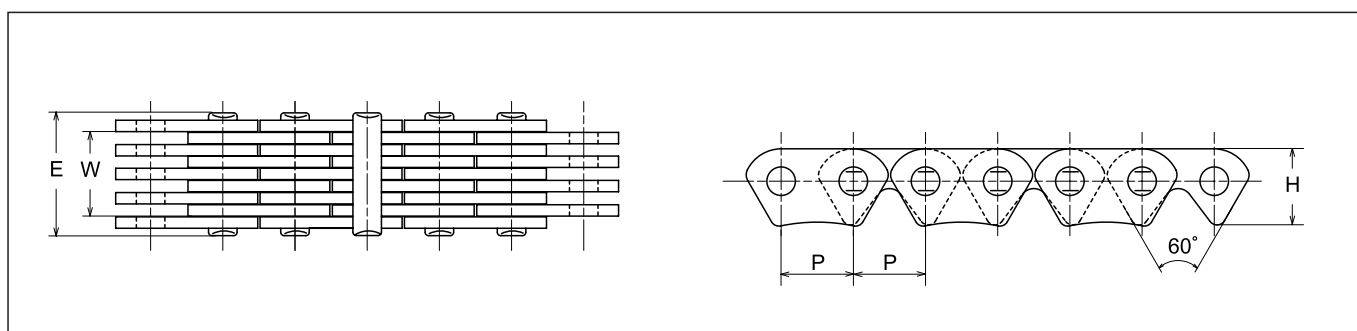
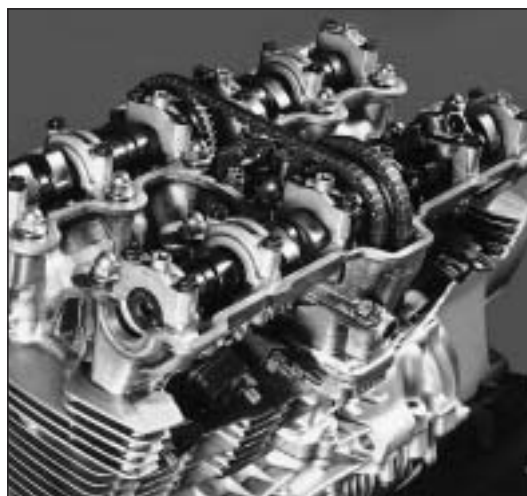
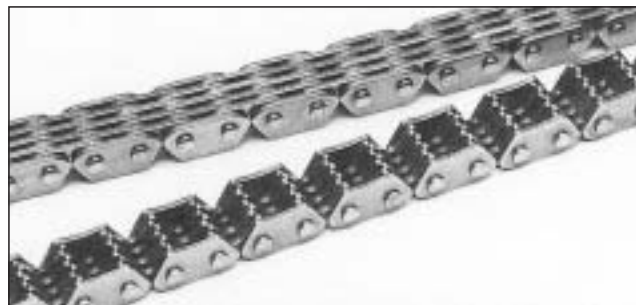

### Dimensions

Unit (mm)

Chain No.	Pitch P	Plate quantity	W	E	H	Min. tensile strength		Approx. weight (kg/m)
						kN	kgf	
<b>DID SCA-0404A SDH</b>	6.35	2×3	3.20	6.00	6.70	6.27	640	0.161
<b>DID SCA-0409A SDH</b>		3×4	5.10	8.10		9.81	1,000	0.238
<b>DID SCA-0412A SDH</b>		4×5	7.15	11.00		12.26	1,250	0.316
<b>DID SCR-0404 SDH</b>	6.35	2×3	3.20	6.00	6.85	6.93	705	0.172
<b>DID SCR-0409 SDH</b>		3×4	5.10	8.10		10.00	1,020	0.255
<b>DID SCR-0412 SDH</b>		4×5	7.15	10.30		13.23	1,350	0.322
<b>DID SC-2614H SDH</b>	8.00	5×4	8.65	12.75	8.70	19.10	1,950	0.520
<b>DID SC-0624A SDH</b>	9.525	6×7	17.65	22.70	10.10	40.99	4,180	1.05
<b>DID SC-0628A SDH</b>		7×8	20.85	26.00		48.05	4,900	1.20

## Silent Chain

### PS silent chain

A PS type silent chain has a structure in which a set of specially formed connecting pins and locker pins contact each other while rotating at each flexible bearing position. Thus, it generates less heat especially in high speed operation and is excellent in durability. Furthermore, the specially formed pins greatly reduce shock when the chain is engaged with sprockets, providing a higher silencing effect than SC silent chains.



### Sprockets

Sprockets for DID silent chains adopt special modules in involute tooth forms for the SCA 04××, SC 25××, SC 06×× on the previous page and PS silent chains to ensure silent high speed operation. For all sizes, the sprocket tooth heads are usually hardened by induction hardening or carburizing.

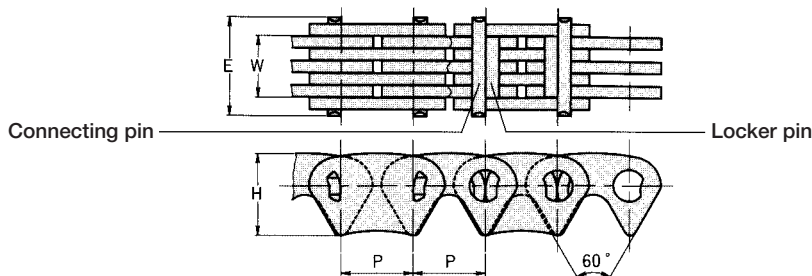

### Dimensions

Unit (mm)

Chain No.	Pitch P	Plate quantity	W	E	H	Min. tensile strength		Approx. weight (kg/m)
						kN	kgf	
<b>DID PS-207 DHA</b>	6.35	6×7	11.30	15.20	7.15	15.4	1,570	0.507
<b>DID PS-314 DHA</b>	9.525	7×8	20.80	26.10	10.85	39.2	4,000	1.19

Note: Combination of plate numbers can be changed upon request.

## Agricultural Roller Chain

The roller chains used for agricultural machinery like tractors, combines, binders, power tillers, and planters that provide higher productivity in modern agriculture are required to have the strength and durability to withstand wear, heavy load and shocks. Agricultural roller chains can sufficiently satisfy these conditions.

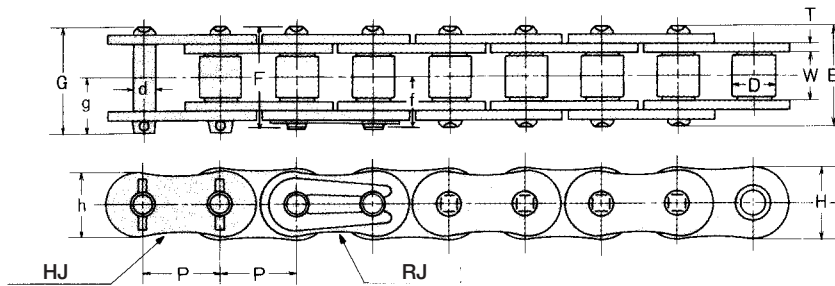

### Dimensions

Unit (mm)

Chain No.	Connecting link	Pitch P	Roller link width W	Roller dia. D	Pin					Plate				Avg. tensile strength		Max. allowable load		Approx. weight (kg/m)		
					d	E	F	f	G	g	T	t	H	h	kN	kgf	kN		kgf	
※DID 35	RJ	9.525	4.78	(5.08)	3.59	12.0	13.1	7.3			1.25	1.25	9.0	7.75	11.2	1,150	2.15	220	0.32	
※DID 35HS	RJ	9.525	4.78	(5.08)	3.59	13.1	13.7	7.8			1.50	1.50	9.0	7.75	12.7	1,300	2.54	260	0.39	
※DID 35HK2	—	9.525	4.78	(5.08)	3.59	15.5	15.4				2.00	2.00	9.0	7.75	19.1	1,950	3.23	330	0.46	
DID 083	RJ	12.70	4.88	7.75	4.09	12.5	13.55	7.35			1.25	1.25	10.3	9.6	13.1	1,340	2.35	240	0.43	
DID 415S	RJ	12.70	4.76	7.77	3.97	13.25	14.3	7.98			1.5	1.5	12.0	10.4	19.1	1,950	3.72	380	0.55	
DID 420	RJ	12.70	6.35	7.77	3.97	14.75	16.15	8.80			1.5	1.5	12.0	10.4	17.8	1,820	3.72	380	0.58	
DID 40	RJ	12.70	7.95	7.92	3.97	16.5	17.6	9.5		10.1	1.5	1.5	12.0	10.4	19.1	1,950	3.72	380	0.68	
DID 40HK	RJ	12.70	7.95	7.92	3.97	18.5	19.50	10.5			2.0	2.0	12.0	10.4	21.5	2,200	4.51	460	0.72	
DID 428	RJ	12.70	7.94	8.50	4.51	16.7	18.05	9.83			1.5	1.5	12.0	10.4	19.6	2,000	3.92	400	0.66	
DID 428H	RJ	12.70	7.94	8.50	4.51	18.9	20.1	10.88			2.0	2.0	12.0	10.4	23.3	2,380	4.90	500	0.76	
DID 520	RJ	15.875	6.35	10.16	5.09	17.45	18.85	10.25			2.0	2.0	15.0	13.0	30.4	3,100	6.86	700	0.89	
DID 50	RJ	15.875	9.53	10.16	5.09	20.3	21.9	11.6		12.0	2.0	2.0	15.0	13.0	30.8	3,150	6.86	700	1.06	
DID 520HK	RJ	15.875	6.35	10.16	5.09	18.6	20.2	10.7			2.4	2.4	15.0	13.0	36.2	3,700	7.84	800	1.00	
DID 50HK	RJ	15.875	9.53	10.16	5.09	21.8	23.4	12.7			2.4	2.4	15.0	13.0	37.6	3,840	8.63	880	1.12	
DID 50Y	—	15.875	9.53	10.22	5.40	22.5					2.4	2.4	15.6	15.6	44.1	4,500	12.74	1,300	1.40	
DID 630K	RJ	19.05	9.53	11.91	5.96	22.1	23.6	12.6			2.4	2.4	18.1	15.6	44.1	4,500	9.31	950	1.37	
DID 630HK	RJ	19.05	9.53	11.91	5.96	25.7	26.8	14.3			3.2	3.2	18.1	15.6	50.5	5,150	10.7	1,100	1.72	
DID 630HKS	RJ	19.05	9.53	11.91	5.96	25.7	26.8	14.3			3.2	3.2	18.1	15.6	53.9	5,500	10.7	1,100	1.72	
DID 630SK	—	19.05	9.53	14.28	7.11	26.25		14.6			3.6	3.2	18.1	18.1	64.7	6,600	10.7	1,100	2.03	
DID 630FSK	—	19.05	9.53	14.28	6.63	27.4					4.0	3.2	19.1	19.1	67.1	6,850	17.6	1,800	2.42	
DID 630FSK2	—	19.05	9.53	14.28	7.11	28.5					4.2	3.4	19.1	19.1	72.5	7,400	17.6	1,800	2.47	
DID 635SK	—	19.05	11.10	14.28	7.11	27.8					3.6	3.2	18.1	18.1	64.7	6,600	10.7	1,100	2.21	
DID 635ST	—	19.05	11.10	14.28	7.51	30.0					4.2	3.4	18.4	18.4	72.5	7,400	10.7	1,100	2.48	
DID 60	RJ	19.05	12.70	11.91	5.96	25.4	26.9	14.3			2.4	2.4	18.1	15.6	44.1	4,500	9.3	950	1.44	
DID 60H	RJ	19.05	12.70	11.91	5.96	28.7	30.5	16.1	31.2		3.2	3.2	18.1	15.6	46.0	4,700	10.7	1,100	1.81	
DID 60HK	RJ	19.05	12.70	11.91	5.96	28.7	30.5	16.1	31.2		3.2	3.2	18.1	15.6	53.9	5,500	10.7	1,100	1.81	
DID 60SK	—	19.05	12.70	14.28	7.11	29.8		16.4			3.6	3.2	18.1	18.1	64.7	6,600	10.7	1,100	2.23	
HI-PWR-S80	HJ	25.40	15.88	15.88	7.94	32.6				35.3	19.0	3.2	3.2	24.1	20.8	84.3	8,600	18.6	1,900	2.82
HI-PWR-S80HK	HJ	25.40	15.88	15.88	7.94	36.1				38.7	20.6	4.0	4.0	24.1	20.8	98.0	10,000	22.5	2,300	3.12
DID 80GS	HJ	25.40	15.88	15.88	8.71	37.7				40.3		4.8	4.0	24.7	24.7	117.0	12,000	27.4	2,800	4.31
HI-PWR-S100	HJ	31.75	19.05	19.05	9.54	39.5				42.8	22.7	4.0	4.0	30.1	26.0	127.0	13,000	30.4	3,100	4.18
HI-PWR-S100HK	HJ	31.75	19.05	19.05	9.54	43.6				46.2	24.4	4.8	4.8	30.1	26.0	145.0	14,800	34.3	3,500	4.37

Note: 1. DID630FSK, DID630FSK2, DID80GS have flat oval-shaped plates.  
 2. The values of max. allowable tension are not applied to connecting links.  
 3. Those marked with ※ are bushing chains.

# BS Roller Chain (British Standard Roller Chain)

DID BS Roller Chains conform to the ISO (International Organization for Standardization) "B series", and they are manufactured in conformity with the British Standard or German Standard. For sprockets, use those in conformity with the BS standard.



## Dimensional drawing

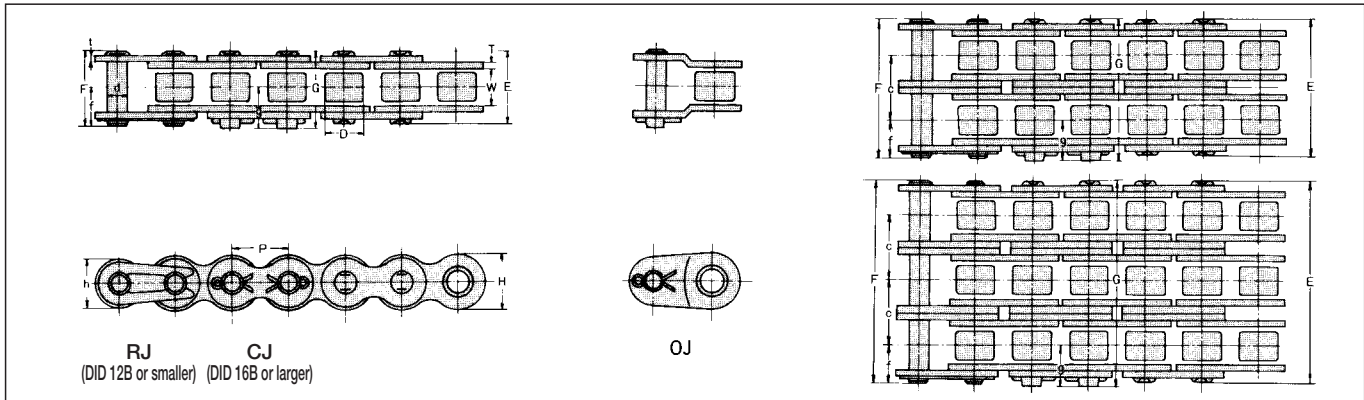

## Dimensions

Unit (mm)

Chain No.		Pitch P	Roller link width W	Roller dia. D	Pin						Transverse pitch C	Plate				JIS Avg. tensile strength		DID Min. tensile strength		Approx. weight (kg/m)
DID	JIS B系				d	E	F	G	f	g		T	t	H	h	kN	kgf	kN	kgf	
DID 04B	—	6.00	2.80	4.00	1.85	6.45	7.35	—	4.15	—	—	0.63	0.63	4.9	4.9	—	—	3.33	340	0.12
DID 05B	05B	—	—	—	—	7.60	8.60	—	—	—	—	—	—	—	—	4.4	449	5.68	580	0.18
DID 05B-2	05B-2	8.00	3.00	5.00	2.31	13.25	14.25	—	4.80	—	5.64	0.75	0.75	7.1	6.2	7.8	795	9.21	940	0.34
DID 06B	06B	—	—	—	—	13.15	13.6	—	—	—	—	—	—	—	—	8.9	908	10.4	1,070	0.39
DID 06B-2	06B-2	9.525	5.72	6.35	3.28	22.75	23.9	—	7.4	—	10.24	1.3	1.0	8.2	8.2	16.9	1,720	19.4	1,980	0.74
DID 06B-3	06B-3	—	—	—	—	33.0	34.3	—	—	—	—	—	—	—	—	24.9	2,539	27.4	2,800	1.10
DID 08B	08B	—	—	—	—	16.7	18.1	—	—	—	—	—	—	—	—	17.8	1,815	19.6	2,000	0.67
DID 08B-2	08B-2	12.70	7.75	8.51	4.45	30.7	32.0	—	9.9	—	13.92	1.5	1.5	11.9	10.4	31.1	3,170	34.3	3,500	1.30
DID 08B-3	08B-3	—	—	—	—	44.6	46.0	—	—	—	—	—	—	—	—	44.5	4,537	49.0	5,000	1.92
DID 10B	10B	—	—	—	—	18.9	20.4	—	—	—	—	—	—	—	—	22.2	2,260	25.4	2,600	0.86
DID 10B-2	10B-2	15.875	9.65	10.16	5.08	35.5	37.0	—	10.9	—	16.59	1.5	1.5	14.7	13.0	44.5	4,537	50.9	5,200	1.68
DID 10B-3	10B-3	—	—	—	—	52.2	53.7	—	—	—	—	—	—	—	—	66.7	6,800	76.4	7,800	2.54
DID 12B	12B	—	—	—	—	22.2	23.6	—	—	—	—	—	—	—	—	28.9	2,946	31.3	3,200	1.14
DID 12B-2	12B-2	19.05	11.68	12.07	5.72	41.7	43.1	—	12.7	—	19.46	1.8	1.8	16.1	14.6	57.8	5,890	62.7	6,400	2.28
DID 12B-3	12B-3	—	—	—	—	61.3	62.7	—	—	—	—	—	—	—	—	86.7	8,840	94.1	9,600	3.46
DID 16B	16B	—	—	—	—	35.1	—	38.2	—	—	—	—	—	—	—	60	6,118	63.7	6,500	2.56
DID 16B-2	16B-2	25.40	17.02	15.88	8.28	67.1	—	70.3	—	20.7	31.88	4.0	3.2	21.0	21.0	106	10,808	127	13,000	5.12
DID 16B-3	16B-3	—	—	—	—	99.1	—	102.2	—	—	—	—	—	—	—	160	16,315	191	19,500	7.59
DID 20B	20B	—	—	—	—	41.0	—	44.0	—	—	—	—	—	—	—	95	9,687	98.0	10,000	3.81
DID 20B-2	20B-2	31.75	19.56	19.05	10.19	77.4	—	80.5	—	23.5	36.45	4.5	3.5	26.4	26.4	170	17,335	196	20,000	7.57
DID 20B-3	20B-3	—	—	—	—	114.0	—	117.0	—	—	—	—	—	—	—	250	25,490	294	30,000	11.3
DID 24B	24B	—	—	—	—	53.4	—	58.7	—	—	—	—	—	—	—	160	16,315	166	17,000	7.08
DID 24B-2	24B-2	38.10	25.40	25.40	14.63	101.8	—	107.1	—	32.0	48.36	6.0	5.0	33.4	33.4	280	28,550	333	34,000	13.9
DID 24B-3	24B-3	—	—	—	—	150.2	—	155.5	—	—	—	—	—	—	—	425	43,337	500	51,000	20.7

- Note: 1. 2POJ offset links are used for DID04B and DID05B.
- 2. DID06B has flat oval-shaped plates.
- 3. Clip connecting links (RJ) are used for DID06B-12B and cotter connecting links (CJ) for DID16B-24B.



## Leaf Chain

Leaf chains consist of pins and plates only and are higher in strength than roller chains. They are suitable for tasks like hoisting and pulling. Leaf chains conform to ANSI and have two types: AL and BL.

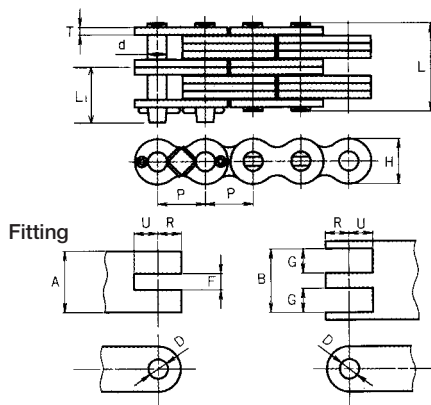



### Dimensions

Unit (mm)

Chain No.	Pitch P	Plate		Pin		Min. tensile strength		Max. allowable load		Approx. weight (kg/m)	Fitting							
		H (Max)	T	d	L (Max)	L1 (Max)	kN	kgf	kN		kgf	b (Min)	R	U (Min)	F (Min)	G (Min)	A (Max)	B (Min)
<b>DID AL 422</b>	12.59	10.4	1.5	3.97	8.1	6.0	16.6	1,700	1.86	190	0.40	4.00	6.3	6.3	—	—	3.0	3.3
<b>DID AL 444</b>					14.6	9.8	33.3	3,400	3.43	350	0.77				3.3	3.3	9.3	9.7
<b>DID AL 466</b>					21.1	12.6	50.0	5,100	3.92	400	1.14				3.3	3.3	15.7	16.1
<b>DID AL 522</b>	15.75	13.0	2.0	5.09	10.5	7.3	27.9	2,850	3.04	310	0.65	5.12	7.9	7.9	—	—	4.0	4.3
<b>DID AL 544</b>					19.0	11.5	55.8	5,700	5.29	540	1.26				4.3	4.3	12.3	12.7
<b>DID AL 566</b>					27.5	15.8	83.8	8,550	6.27	640	1.85				4.3	4.3	20.7	21.1
<b>DID AL 622</b>	19.05	15.6	2.4	5.96	12.5	8.8	38.2	3,900	4.41	450	0.90	6.00	9.5	9.5	—	—	4.8	5.1
<b>DID AL 644</b>					22.7	13.9	76.4	7,800	7.45	760	1.75				5.1	5.1	14.7	15.1
<b>DID AL 666</b>					32.8	19.0	114	11,700	8.72	890	2.59				5.1	5.1	24.7	25.1
<b>DID AL 822</b>	25.28	20.8	3.2	7.94	16.4	11.0	66.6	6,800	7.35	750	1.55	8.00	12.7	12.7	—	—	6.4	6.8
<b>DID AL 844</b>					29.7	17.8	133	13,600	13.2	1,350	3.04				6.8	6.8	19.8	20.1
<b>DID AL 866</b>					43.1	24.5	200	20,400	15.3	1,570	4.51				6.8	6.8	32.9	33.4
<b>DID AL 1022</b>	31.64	26.0	4.0	9.54	19.1	13.1	100	10,200	11.5	1,180	2.46	9.60	15.8	15.8	—	—	8.0	8.4
<b>DID AL 1044</b>					36.4	21.3	200	20,400	20.5	2,100	4.80				8.4	8.4	24.4	24.9
<b>DID AL 1066</b>					53.1	29.7	423	30,600	24.0	2,450	7.15				8.4	8.4	40.9	41.4
<b>DID AL 1222</b>	37.98	31.2	4.8	11.11	23.8	15.3	141	14,400	16.4	1,680	3.32	11.20	19.0	19.0	—	—	9.6	10.0
<b>DID AL 1244</b>					43.4	25.2	282	28,800	29.1	2,970	6.50				10.0	10.0	29.2	29.7
<b>DID AL 1266</b>					63.4	35.1	423	43,200	34.2	3,490	9.68				10.0	10.0	48.9	49.4
<b>DID AL 1444</b>	44.32	36.3	5.6	12.71	50.6	30.1	372	38,000	38.9	3,970	10.0	12.80	22.2	22.2	11.6	11.6	34.0	34.5
<b>DID AL 1446</b>					73.6	41.6	558	57,000	46.0	4,700	14.6				11.6	11.6	56.9	57.4
<b>DID AL 1644</b>					83.6	46.4	706	72,000	58.8	6,000	19.6				13.2	13.2	38.8	39.4
<b>DID AL 1666</b>	50.62	41.4	6.4	14.29	83.6	46.4	706	72,000	58.8	6,000	19.6	14.40	25.4	25.4	13.2	13.2	64.9	65.5
<b>DID BL 423</b>	12.70	12.0	2.0	5.09	12.5	8.5	24.5	2,500	4.51	460	0.86	5.12	6.3	6.3	—	—	6.0	6.3
<b>DID BL 434</b>					16.9	10.6	37.2	3,800	5.29	540	1.16				4.3	4.3	10.3	10.7
<b>DID BL 446</b>					23.2	13.7	49.0	5,000	5.98	610	1.69				4.3	4.3	16.3	16.8
<b>DID BL 523</b>	15.875	15.0	2.4	5.96	15.0	9.9	39.2	4,000	6.86	700	1.30	6.00	7.9	7.9	—	—	7.2	7.5
<b>DID BL 534</b>					20.2	12.5	58.8	6,000	8.33	850	1.73				2.6	5.1	12.3	12.7
<b>DID BL 546</b>					27.7	16.3	78.4	8,000	9.41	960	2.44				5.1	7.6	19.5	20.0
<b>DID BL 623</b>	19.05	18.1	3.2	7.94	19.8	12.6	68.6	7,000	9.80	1,000	2.08	8.00	9.5	9.5	—	—	9.7	10.0
<b>DID BL 634</b>					26.7	16.2	103	10,500	12.2	1,250	2.85				3.4	6.8	16.2	16.9
<b>DID BL 646</b>					36.7	21.1	127	13,000	13.7	1,400	4.07				6.8	10.1	26.0	26.6
<b>DID BL 823</b>	25.40	24.0	4.0	9.54	24.0	15.3	102	10,500	16.9	1,730	3.25	9.60	12.7	12.7	—	—	12.1	12.4
<b>DID BL 834</b>					32.4	19.3	154	15,800	20.5	2,100	4.50				4.2	8.4	20.2	20.9
<b>DID BL 846</b>					44.8	25.5	205	21,000	23.5	2,400	6.39				8.4	12.5	32.4	33.0
<b>DID BL 1023</b>	31.75	29.9	4.8	11.11	28.6	17.7	141	14,400	25.9	2,650	4.33	11.20	15.8	15.8	—	—	14.4	14.8
<b>DID BL 1034</b>					38.6	22.7	220	22,500	31.3	3,200	6.03				5.0	10.0	24.2	24.9
<b>DID BL 1046</b>					53.9	30.2	282	28,800	36.2	3,700	8.53				10.0	14.9	38.8	39.4
<b>DID BL 1223</b>	38.10	35.9	5.6	12.71	33.3	21.5	193	19,700	36.7	3,750	6.06	12.80	19.0	19.0	—	—	16.8	17.3
<b>DID BL 1234</b>					44.8	27.2	313	32,000	44.1	4,500	8.45				5.9	11.6	28.0	28.8
<b>DID BL 1246</b>					61.7	36.1	386	39,400	50.5	5,150	12.0				11.6	17.4	45.2	45.9
<b>DID BL 1423</b>	44.45	41.9	6.4	14.29	37.6	23.4	254	26,000	49.0	5,000	8.74	14.40	22.2	22.2	—	—	19.2	19.7
<b>DID BL 1434</b>					50.7	30.0	421	43,000	58.8	6,000	10.9				6.7	13.2	32.0	32.8
<b>DID BL 1446</b>					70.4	39.8	509	52,000	67.6	6,900	20.3				13.2	19.8	51.6	52.3
<b>DID BL 1623</b>	50.80	47.8	7.1	17.46	41.7	26.7	353	36,000	58.8	6,000	11.9	17.60	25.4	25.4	—	—	21.3	21.8
<b>DID BL 1634</b>					56.4	34.0	554	56,500	70.6	7,200	16.6				7.4	14.6	35.5	36.3
<b>DID BL 1646</b>					78.0	44.8	706	72,000	80.4	8,200	23.6				14.6	11.9	57.2	57.9

Note: 1. Except for Al-60 series, the pitch of AL type chains is slightly different to that of ANSI standard.  
2. The values of max. allowable tension are not applied to connecting links.

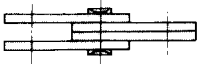
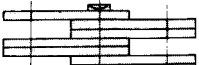
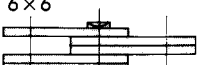

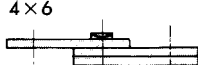
AL type	BL type
For the use that static load is applied with little concern of wearing.	For the use that wear resistance is required since impact load is applied.
<p>2 × 2</p>  <p>4 × 4</p>  <p>6 × 6</p> 	<p>2 × 3</p>  <p>3 × 4</p>  <p>4 × 6</p> 

### Selection of leaf chains

The chain size is selected according to the following formula:

- Acting tension × Service factor ≤ Maximum allowable tension
- Notes: 1. Acting tension includes the dead weight of the chain, the weight of the attachments and inertia.  
2. If the chain speed exceeds 30 m/min, use a DID roller chain.

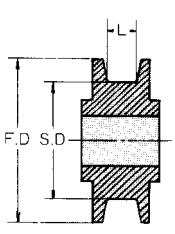

Minimum sheave diameter:  $S.D = \text{Chain pitch} \times 5$

Minimum width between flanges:  $L = \text{Overall length of pin} \times 1.05$

- If connecting pins are provided:  $L \geq 2L_1 \times 1.05$   
L1 is the value stated in the dimensions table.

$F.D = S.D + \text{Maximum link plate height (H)}$

Note: • If dimension H exceeds 25.4,  $F.D = S.D + 25.4$  can be adopted as the minimum flange outer diameter.







### Service factor

Type of Impact	Service factor	Examples of applications	Applicable chains
Smooth transmission When starts and stops are smooth and loads hardly vary.	1.0	For lifting a balance weight, stretching in cold and hot processing etc.	AL type
With some shock When starts, stops, load variations or reversing occurs often.	1.2	Forklift, etc.	AL type and BL type
With large shock When sudden start, stop or reversing occurs and load largely varies.	1.4	Mining and construction machinery, etc.	BL type and DID roller chains

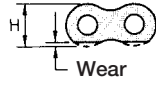
### Periodical inspection and instructions for replacement

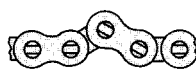
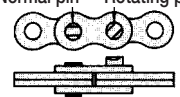
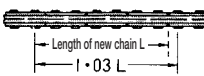
Be sure to carry out periodical inspection and lubrication to confirm safety and prolong chain life. Problems, possible causes and instructions for solution are outlined in the following table.

### Periodical inspection table

Problem	Possible cause	Solution
<p>Circumferential wear of plate</p> 	Wear	Replace the chain if wear loss becomes 5 percent of H.
<p>Oblique wear of plate and pin head</p> 	Misalignment of guide or pulleys	Align the unit.
<p>Stiff link</p> 	<p>Dust or foreign substances are contained in a bending portion</p> <p>Corrosion and rust</p> <p>Bent pin</p>	<p>Wash and lubricate.</p> <p>Replace the chain.</p> <p>Replace the chain.</p>
<p>Abnormal protrusion or rotation of pin head</p> 	Excessive tension by overload or insufficient lubrication	Replace the chain Lubricate and eliminate overload.
<p>Wear elongation</p> 	Wear	<p>Replace the chain when its length becomes 1.03L.</p> <p>Note: Wear elongation of a chain lowers its tensile strength.</p> <p>Wear elongation of 3% lowers the tensile strength by 18 percent.</p> <p>The wear life of chain can be improved by lubrication.</p> <p>Replace the chain.</p>
<p>Cracked plate (1)</p>  <p>Crack: From the hole of a link plate toward the end of the link plate in the direction perpendicular to tension direction.</p>	Load exceeding the allowable tension of chain	Replace the chain with a chain of higher maximum allowable tension, or lower the load or dynamic (shock) load.
<p>Cracked plate (2)</p>  <p>Crack: In an oblique direction against tension direction.</p>	Heavy rust or exposure to an acid or corrosive material	Replace the chain, and protect from corrosive circumstances.
<p>Broken plate (by high tension)</p> 	Overload	Replace the chain, and eliminate the cause of overload.
<p>Enlarged plate hole</p> 	Overload	Replace the chain, and eliminate the cause of overload.
<p>Corrosion of pit</p>	Corrosive circumstances	Replace the chain, and protect from corrosive circumstances.
<p>Wear of connecting pin</p>	Normal wear	Replace the worn component.

## Roller Chain Coupling

### Features

#### 1. Simple structure

A roller chain coupling consists of one duplex roller chain and two sprockets for a simplex chain. Handling is very simple as both the shafts (driving shaft and driven shaft) can be connected and disconnected by inserting or removing connecting pins (cotter type).

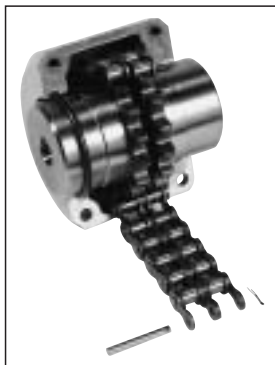

#### 2. Easy alignment

Owing to the play between the respective components of the chain and the play between the roller chain and the sprockets, the eccentricity and angle error can be generally allowed as follows:

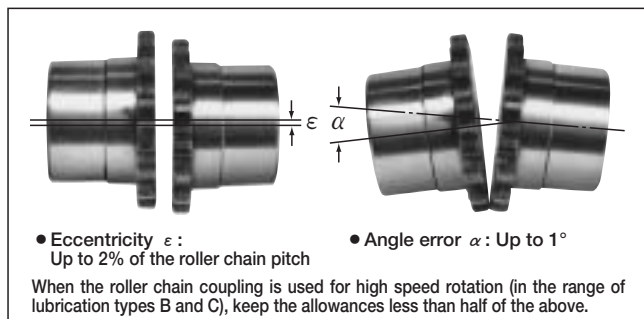

#### 3. Small but powerful

Since a powerful roller chain is engaged with the sprockets at all the teeth, a large torque can be transmitted, though the coupling itself is smaller than other kinds of couplings.

#### 4. Excellent durability

The roller chain is made of heat-treated steel and manufactured precisely and solidly to the highest manufacturing standard. The durability is outstanding and little time is required for maintenance as the sprockets have induction-hardened special teeth, and are always engaged with the roller chain.

#### 5. Protection of machine

Rational flexibility decreases vibration, overheating and wear of the bearings caused by the eccentricities and angle errors of the shafts.

#### Standard housing

The standard housings for No. 8022 or smaller are made of aluminum alloy die casting, and those for No. 10020 or larger are made of aluminum alloy casting. Installation of housings has the following advantages.



### 1. Advantages of housing

- **Holding of lubrication**  
Since a roller chain coupling rotates with flexibility, the teeth of the roller chain and sprockets slide slightly during operation. So, they must be kept lubricated for prevention of wear as much as possible. The housing functions as a grease box for the lubrication.
- **Prevention of grease scattering**  
Especially in high speed rotation, grease may be scattered by centrifugal force. The housing functions as a protector that prevents this.
- **Protection from dust and moisture (corrosive atmosphere)**  
When a roller chain coupling is used in a wear-causing or corrosive circumstances, the chain life is extremely shortened unless the coupling is perfectly shielded from the circumstances. The housing functions to protect the roller chain coupling, preventing the shortening of life.
- **High safety and neat appearance**  
Since the housing has no protrusions outside, it is safe even if it rotates with the roller chain coupling. It is also neat in appearance. (To avoid possible injury, do not touch the housing when rotating.)

### 2. Structure

The roller chain coupling can be split in the direction perpendicular to the shafts. The hole on the driving shaft side of the housing firmly holds the coupling's sprocket hub. The hole on the driven shaft side keeps a clearance of 1 mm or more from the sprocket hub to maintain flexibility of the coupling. Oil leakage from this portion is prevented by a seal ring.

### Cautions

- |   |  |
|---|--|
| For safe work   | <ul style="list-style-type: none"> <li>• Always wear clothing suitable for work and proper protection (safety glasses, safety shoes, etc.).</li> <li>• Strictly observe Section 1 "General standards (prevention of danger by motors, revolving shafts, etc.), Chapter 1, Part 2 of Occupational Safety and Health Regulations.</li> <li>• Be sure to switch off the electric power source or any other power source before starting maintenance work, and ensure that the power is never accidentally switched on. Furthermore, make sure not to allow your clothes or any parts of the body to be caught by the chain or sprockets, or by any other nearby equipment.</li> </ul> |
| Housings and safety covers                                  | <ul style="list-style-type: none"> <li>• Be sure to install a chain housing for type C and type B (see "Table of Lubrication Types").</li> <li>• For installing the roller chain coupling into a high-speed machine or heavily vibrating machine, coat the bolts with a loosening preventive.</li> <li>• Install a safety cover to prevent any unexpected flying of loosened bolts, or scattering of a broken housing or chain.</li> </ul>   |
| Inhibition of modification, re-use, and partial replacement | <ul style="list-style-type: none"> <li>• Never partially replace or re-use the coupling as its strength will be lowered, causing damage or destruction. Furthermore, since the coupling is heat-treated, never modify the cotter holes or any other parts. When replacement is necessary, replace the roller chain coupling or housing as a set respectively.</li> </ul>   |
| Noise   | <ul style="list-style-type: none"> <li>• Noise during operation may be caused by malfunction and the unit may need to be replaced. Immediately switch off the power, and check the cause.</li> </ul>   |

## Lubrication of roller chain coupling

The lubrication of a roller chain coupling belongs to the following three types: A, B and C, depending on the speed of rotation used. Refer to the table of Max. Horsepower Ratings (P112).

### 1. Lubrication types

Type A	Greasing once a month.
Type B	Greasing every 1 ~ 2 weeks, or install a lubrication housing.
Type C	Be sure to install a housing, and replace grease every 3 months.

### 2. Grease

Since a roller chain coupling is usually used at high speed for a long time, grease must satisfy the following conditions.

- Excellent in mechanical stability, oxidation stability and adhesion.
- Grease based on metallic soap: For low speed

operation, grease based on sodium soap, i.e., fiber grease can be used, but for high speed operation (for lubrication type B and C), be sure to use grease based on lithium soap.

### 3. Greasing amount

Fill appropriate amount of grease in the housing in accordance with the following table.

Roller chain coupling No.	Required amount of grease kg	Roller chain coupling No.	Required amount of grease kg
<b>DID C-4012</b>	0.10	<b>DID C-10020</b>	1.8
<b>DID C-4014</b>	0.13	<b>DID C-12018</b>	3.2
<b>DID C-4016</b>	0.17	<b>DID C-12022</b>	4.4
<b>DID C-5014</b>	0.22	<b>DID C-16018</b>	7.2
<b>DID C-5016</b>	0.26	<b>DID C-16022</b>	9.9
<b>DID C-5018</b>	0.36	<b>DID C-20018</b>	11.8
<b>DID C-6018</b>	0.5	<b>DID C-20022</b>	15.8
<b>DID C-6022</b>	0.7	<b>DID C-24022</b>	21.9
<b>DID C-8018</b>	0.9	<b>DID C-24026</b>	28.1
<b>DID C-8022</b>	1.2		

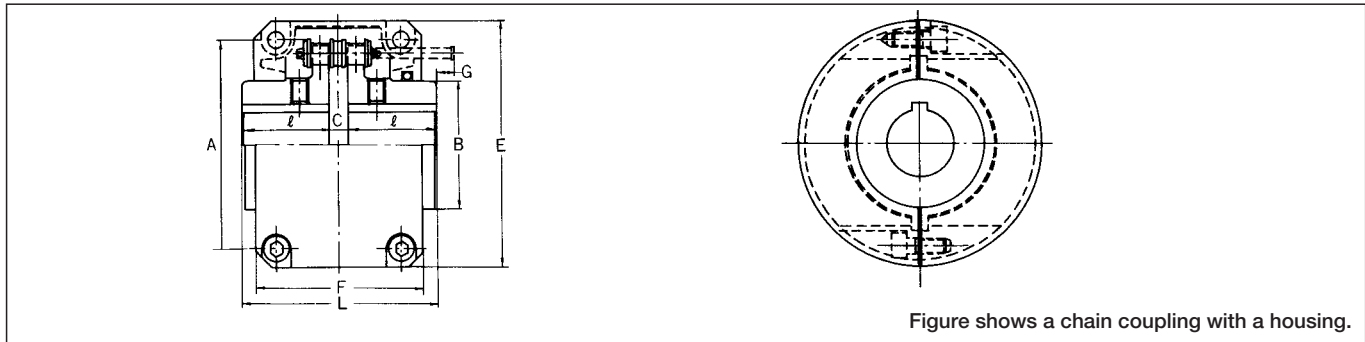

Figure shows a chain coupling with a housing.

## Dimensions

Roller chain coupling No.		Applicable range of shaft dia.	Prepared hole dia.	E	F	A (max.)	L	l	C	B	G	Set screw	Max. allowable torque of under 50rpm		Allowable rotation (r/min)	Approx. weight (kg)	Moment of inertia $\times 10^{-3}$ kg·m	GD <sup>2</sup> $\times 10^{-3}$ kgf·m <sup>2</sup>
DID	JIS												kN·m	kgf·m				
<b>DID C-4012</b>	4012	11~22	10	75	75	61	79.4	36	7.4	35	9	M 6	0.249	25.4	4,800	1.1	0.55	2.20
<b>DID C-4014</b>	4014	14~28	10	84	75	69	79.4	36	7.4	43	9	M 6	0.329	33.6	4,800	1.3	0.97	3.85
<b>DID C-4016</b>	4016	16~32	14	92	75	77	87.4	40	7.4	50	6	M 6	0.419	42.8	4,800	1.85	1.44	5.76
<b>DID C-5014</b>	5014	16~35	14	102	85	86	99.7	45	9.7	53	11	M 8	0.620	63.3	3,600	2.7	2.80	11.2
<b>DID C-5016</b>	5016	18~40	14	111	85	96	99.7	45	9.7	60	11	M 8	0.791	80.7	3,600	3.25	3.70	14.8
<b>DID C-5018</b>	5018	18~45	14	122	85	106	99.7	45	9.7	70	11	M 8	0.979	99.9	3,000	4.25	5.63	22.5
<b>DID C-6018</b>	6018	22~56	18	142	106	128	123.5	56	11.5	85	15	M10	1.81	185	2,500	7.3	13.73	54.9
<b>DID C-6022</b>	6022	28~75	18	167	106	152	123.5	56	11.5	110	15	M10	2.61	267	2,500	11.6	29.5	118
<b>DID C-8018</b>	8018	32~80	23	186	130	170	141.2	63	15.2	115	27	M12	3.92	400	2,000	16.15	52.0	208
<b>DID C-8022</b>	8022	40~100	28	220	130	203	157.2	71	15.2	140	19	M12	5.64	576	1,800	24.3	111	444
<b>DID C-10020</b>	10020	45~110	40	255	160	233	178.8	80	18.8	160	29	M12	8.40	857	1,800	39.7	244	976
<b>DID C-12018</b>	12018	50~125	45	280	184	255	202.7	90	22.7	170	47	M12	12.7	1,300	1,500	53.8	394	1,575
<b>DID C-12022</b>	12022	56~140	50	330	190	303	222.7	100	22.7	200	37	M12	18.3	1,870	1,250	77.1	781	3,122
<b>DID C-16018</b>	16018	63~160	55	375	240	340	254.1	112	30.1	225	64	M16	26.4	2,700	1,100	108	1,453	5,811
<b>DID C-16022</b>	16022	80~200	70	440	245	405	310.1	140	30.1	280	36	M16	38.1	3,890	1,000	187	3,222	12,890
<b>DID C-20018</b>	—	82~205	75	465	285	425	437.5	200	37.5	290	15	M20	54.1	5,520	800	286	5,098	20,390
<b>DID C-20022</b>	—	100~255	90	545	300	506	477.5	220	37.5	360	—	M20	77.8	7,940	600	440	11,110	44,450
<b>DID C-24022</b>	—	120~310	110	650	340	607	650	302.5	45.0	445	—	M20	137	14,000	600	869	31,000	124,100
<b>DID C-24026</b>	—	150~360	140	745	350	704	700	327.5	45.0	525	—	M20	186	19,000	500	1,260	59,850	239,400

Note: 1. Dimension G indicates the required margin for assembling and disassembling of the roller chain coupling.

2. Allowable rotation is applicable only when the housing is mounted.

3. The weight of the housing and grease is included in Approx. weight and GD<sup>2</sup>.

## Selection of roller chain coupling

### 1. Selection by drive performance

- Based on the type of motor, operation time per day, and the type of load, obtain the service factor in the table of service factors.
- Multiply the power (kW) to be transmitted, by the service factor identified in the following table, to obtain a corrected power to be transmitted (kW).  
 $\text{Transmission power (kW)} \times (\text{Service factor}) = \text{Corrected transmission power (kW)}$

**Table of Service Factor**

Type of load	Operating time/day	Source of power		
		Electric motor or turbine	Steam engine/gasoline engine (with 4 cylinders or more)	Diesel engine/gas engine
Load variation, impact, start torque is small (No reverse)	8 hrs or less	1.0	1.5	2.0
	8-16 hrs	1.5	2.0	2.5
	16 hrs or more	2.0	2.5	3.0
Load variation, impact is at medium level (No reverse)	8 hrs or less	1.5	2.0	2.5
	8-16 hrs	2.0	2.5	3.0
	16 hrs or more	2.5	3.0	3.5
Load variation, impact, start torque is large, (No reverse)	8 hrs or less	2.0	2.5	3.0
	8-16 hrs	2.5	3.0	3.5
	16 hrs or more	3.0	3.5	4.0

Note: Service factor of 8 hours or less to be applied regardless of operation time when the revolution is under 50 r/min.

- Select a roller chain coupling in the drive performance (kW ratings) table: Identify the chain coupling number when the transmission power starts to exceed the corrected transmission power (calculated in 2.) according to the motor rpm.
- When the shaft diameter is within the range of the selected roller chain coupling shaft diameter, select the coupling. When the shaft diameter exceeds the maximum shaft diameter of the roller chain coupling, select a one size larger coupling.

A table of ANSI key slot dimensions is shown on the following page.

### 2. Selection when connected with an electric motor directly

Low voltage three-phase squirrel-cage induction motor (ANSI standard)			Roller chain coupling No.
Output (kW)		Shaft dia. (mm)	
4 poles	6 poles	E type	
0.4	—	14	<b>DID C-4012</b>
0.75	0.4	19	
1.5	0.75	24	<b>DID C-4016</b>
2.2	1.5	28	
3.7	2.2	28	
5.5	3.7	38	<b>DID C-5016</b>
7.5	5.5	38	
11	7.5	42	<b>DID C-5018</b>
—	11	42	

- Note: 1. Drive performance selecting method to be applied when the output of motor exceeds 15 kW.  
 2. Table of dimensions of roller chain coupling is applied when the shaft diameter of motor is not given in the table above.

## Drive performance (kW ratings)

Roller chain coupling No.	Max. allowable torque under 50 r/min		Number of revolution (r/min)																				Unit (kW)					
	kN·m	kgf·m	1	5	10	25	50	100	200	300	400	500	600	800	1000	1200	1500	1800	2000	2500	3000	3600		4000	4800	5200	6000	
<b>DID C-4012</b>	0.249	25.4	0.03	0.13	0.26	0.65	1.31	2.00	3.11	4.06	4.91	5.72	6.48	7.94	9.33	10.6	12.6	14.5	15.7	18.9	21.9	25.6	28.1	33.0				
<b>DID C-4014</b>	0.329	33.6	0.03	0.17	0.35	0.86	1.73	2.65	4.12	5.37	6.50	7.56	8.58	10.5	12.3	14.1	16.7	19.2	20.8	25.0	29.0	33.9	37.1	43.6				
<b>DID C-4016</b>	0.419	42.8	0.04	0.22	0.44	1.10	2.20	3.38	5.25	6.84	8.28	9.64	10.9	13.3	15.7	17.9	21.2	24.5	26.6	31.8	37.0	43.2	47.3	55.6				
<b>DID C-5014</b>	0.620	63.3	0.07	0.33	0.65	1.63	3.25	4.99	7.75	10.1	12.2	14.2	16.1	19.7	23.2	26.5	31.4	36.1	39.3	47.0	54.7	63.8						
<b>DID C-5016</b>	0.791	80.7	0.08	0.41	0.83	2.07	4.14	6.35	9.88	12.8	15.5	18.1	20.5	25.1	29.5	33.8	40.0	46.1	50.0	59.9	69.7	81.3						
<b>DID C-5018</b>	0.979	99.9	0.10	0.51	1.03	2.57	5.13	7.87	12.2	15.9	19.3	22.4	25.4	31.1	36.6	41.8	49.5	57.0	62.0	74.2	86.3							
<b>DID C-6018</b>	1.81	185	0.19	0.95	1.91	4.77	9.54	14.6	22.7	29.6	35.8	41.7	47.3	57.9	68.1	77.8	92.1	106	115	138								
<b>DID C-6022</b>	2.61	267	0.27	1.37	2.74	6.86	13.7	21.0	32.7	42.6	51.6	60.0	68.1	83.4	97.9	112	132	152	165	198								
<b>DID C-8018</b>	3.92	400	0.41	2.06	4.11	10.2	20.6	31.5	49.0	63.8	77.3	89.9	102	124	146	167	198	228	248									
<b>DID C-8022</b>	5.64	576	0.59	2.96	5.91	14.8	29.6	45.3	70.4	91.8	111	129	146	179	211	241	285	329	357									
<b>DID C-10020</b>	8.40	857	0.88	4.40	8.80	22.0	44.0	67.4	104	136	165	192	218	267	314	359	425	489										
<b>DID C-12018</b>	12.7	1,300	1.33	6.67	13.3	33.4	66.7	102	159	207	251	292	331	405	476	544	644											
<b>DID C-12022</b>	18.3	1,870	1.92	9.60	19.2	48.0	96.0	147	228	298	361	420	476	583	685	783												
<b>DID C-16018</b>	26.4	2,700	2.78	13.9	27.8	69.5	139	213	331	431	523	608	690	845	992													
<b>DID C-16022</b>	38.1	3,890	4.00	20.0	40.0	100	200	306	476	621	752	875	992	1210	1420													
<b>DID C-20018</b>	54.1	5,520	5.67	28.3	56.7	142	283	434	675	880	1060	1240	1400	1720														
<b>DID C-20022</b>	77.8	7,940	8.15	40.8	81.5	204	408	625	971	1260	1530	1780	2020															
<b>DID C-24022</b>	137	14,000	14.4	72.2	144	361	722	1100	1720	2240	2710	3160	3580															
<b>DID C-24026</b>	186	19,000	19.5	97.7	195	489	977	1490	2320	3030	3670	4270																
Type of lubrication	A		B					C																				

Note: Please refer to P133 for type of lubrication

### 3. Dimensions of ANSI key slot

#### New ANSI key slot (ANSI 1301-1976)

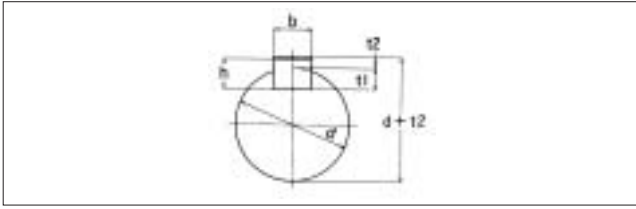

Shaft dia. <b>d</b>	Dimension of key 幅×高 <b>b×h</b>	Depth of key slot			
		Shaft <b>t1</b>	Hub <b>d+t2</b>		
			Parallel key	Sloped key	
Over 6 8 or less	2×2	1.2	d+ 1.0	d+ 0.5	
8 ∕ 10 ∕	3×3	1.8	d+ 1.4	d+ 0.9	
10 ∕ 12 ∕	4×4	2.5	d+ 1.8	d+ 1.2	
12 ∕ 17 ∕	5×5	3.0	d+ 2.3	d+ 1.7	
17 ∕ 22 ∕	6×6	3.5	d+ 2.8	d+ 2.2	
20 ∕ 25 ∕	(7×7)	4.0	d+ 3.0	d+ 3.0	
22 ∕ 30 ∕	8×7	4.0	d+ 3.3	d+ 2.4	
30 ∕ 38 ∕	10× 8	5.0	d+ 3.3	d+ 2.4	
38 ∕ 44 ∕	12× 8	5.0	d+ 3.3	d+ 2.4	
44 ∕ 50 ∕	14× 9	5.5	d+ 3.8	d+ 2.9	
50 ∕ 55 ∕	(15×10)	5.0	d+ 5.0	d+ 5.0	
50 ∕ 58 ∕	16×10	6.0	d+ 4.3	d+ 3.4	
58 ∕ 65 ∕	18×11	7.0	d+ 4.4	d+ 3.4	
65 ∕ 75 ∕	20×12	7.5	d+ 4.9	d+ 3.9	
75 ∕ 85 ∕	22×14	9.0	d+ 5.4	d+ 4.4	
80 ∕ 90 ∕	(24×16)	8.0	d+ 8.0	d+ 8.0	
85 ∕ 95 ∕	25×14	9.0	d+ 5.4	d+ 4.4	
95 ∕ 110 ∕	28×16	10.0	d+ 6.4	d+ 5.4	
110 ∕ 130 ∕	32×18	11.0	d+ 7.4	d+ 6.4	
125 ∕ 140 ∕	(35×22)	11.0	d+11.0	d+11.0	
130 ∕ 150 ∕	36×20	12.0	d+ 8.4	d+ 7.1	
140 ∕ 160 ∕	(38×24)	12.0	d+12.0	d+12.0	
150 ∕ 170 ∕	40×22	13.0	d+ 9.4	d+ 8.1	
160 ∕ 180 ∕	(42×26)	13.0	d+13.0	d+13.0	
170 ∕ 200 ∕	45×25	15.0	d+10.4	d+ 9.1	
200 ∕ 230 ∕	50×28	17.0	d+11.4	d+10.1	

#### ANSI parallel, sloped key slot (ANSI B 1301-1959)

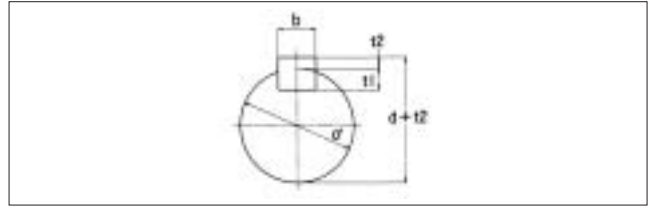

Shaft dia. <b>d</b>	Dimension of key 幅×高 <b>b×h (t2+t1)</b>	Depth of key slot	
		Shaft <b>t1</b>	Hub <b>d+t2</b>
		10 or more 13 or less	4× 4
Over 13 20 ∕	5× 5	3.0	d+ 2.0
20 ∕ 30 ∕	7× 7	4.0	d+ 3.0
30 ∕ 40 ∕	10× 8	4.5	d+ 3.5
40 ∕ 50 ∕	12× 8	4.5	d+ 3.5
50 ∕ 60 ∕	15×10	5	d+ 5
60 ∕ 70 ∕	18×12	6	d+ 6
70 ∕ 80 ∕	20×13	7	d+ 6
80 ∕ 95 ∕	24×16	8	d+ 8
95 ∕ 110 ∕	28×18	9	d+ 9
110 ∕ 125 ∕	32×20	10	d+10
125 ∕ 140 ∕	35×22	11	d+11
140 ∕ 160 ∕	38×24	12	d+12
160 ∕ 180 ∕	42×26	13	d+13
180 ∕ 200 ∕	45×28	14	d+14
200 ∕ 224 ∕	50×31.5	16	d+15.5
224 ∕ 250 ∕	56×35.5	18	d+17.5



## DID C-Top (Chain Cover) PAT.

DID C-Top is a plastic cover for chains that can be easily attached. It has sufficient load strength for chains conveying goods. Unlike conventional plastic chains, it can be used under high tension as stainless steel chains. It is an ideal solution for the use that requires the strength of steel chains free from concerns of damaging, soiling, and jamming of products. It also prevents operators from being caught by the chains. It can also be used as the cover for chains used for elevating devices such as multilevel parking machines.

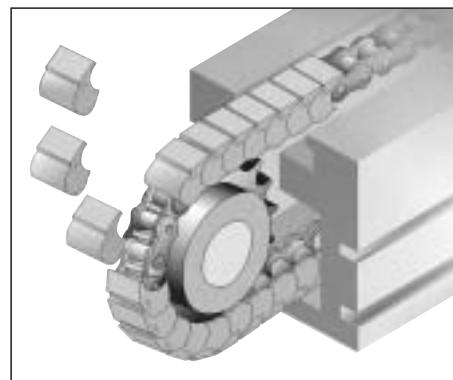

Note: Stock product

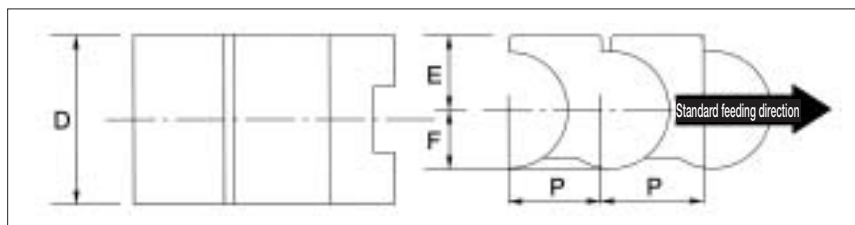

### Applicable chains

Can be attached to chains corresponding to ANSI #40, 50, 60.

### Sprocket teeth number

Use sprockets with 12 or more teeth.  
※Check the outer diameter of the hub.

### Color

The standard color for this product is blue gray. Other colors can be provided depending on the quantity. Consult us.

### Dimensions

Unit (mm)

Cover No.	Dimension (mm)				Weight (g/link) *A, B
	P	D	E	F	
<b>DID CT-40</b>	12.70	27	10	7.6	4.5
<b>DID CT-50</b>	15.88	32	12	9.5	7.6
<b>DID CT-60</b>	19.05	37	14	11.2	11.5

●Material: POM ●200/package

### Live load

<b>DID CT-40</b>	6kg/pitch
<b>DID CT-50</b>	8kg/pitch
<b>DID CT-60</b>	10kg/pitch

## DID Chain Lube (420 ml)/ DID HI-PWR Lube (330 ml)

Chain Lube is a spray type lubricant that was developed specifically for chains. It has outstanding features that lengthens the chain life preventing it from wearing and maximizes the chain's transmission efficiency.

### Applications

- Roller Chains for Power Transmissions
- O-ring chains
- Leaf chains
- General conveyor chains
- Motorcycle chains
- Bicycle chains
- Sprockets

### Features

- Good adhesion and less splatter.
- Good lubricity to enhance wear resistance.
- Good penetration.
- High corrosion prevention effect.
- Good water resistance and unlikely to be washed away by water.
- Excellent heat resistance.
- Does not impair the O-rings.

- Set number: Chain Lubes: 24/case, HI-PWR Lubes: 48/case
- Stock product



Chain lube  
(Mainly for drive use)



HI-PWR lube  
(Mainly for conveyor use)

## Chain Wear-elongation Check Gage

This gage checks the wear-elongation of chains.

- Check the chain elongation at a portion which is most frequently engaged with the sprockets (portion most likely to be worn).
  - When the center of the pin of the chain to be measured reaches the arrow point, it means that the chain has been critically elongated. In this case, replace the chain.
- ※Use the gage to check the wear elongation of your chain.



Note: Stock product



## General terms for sprockets

### Nominal number of sprockets

The nominal number of a sprocket is the same as the nominal number of the corresponding chain. For example, Chains such as DID50, DID50HK, and DID 50LD can be engaged with a sprocket DID50. It is followed by symbols and characters indicating the number of chain strands, the number of sprocket teeth, hub type, tooth head hardening, etc.

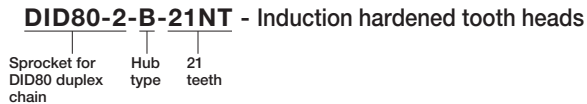

### Diameter of prepared hole and shaft hole finishing

A standard sprocket for a single strand or double strand chain has a shaft hole prepared at a diameter stated in the table of dimensions. When you finish the shaft hole, machine it in reference to the outer diameter or root diameter. For reference, the table of ANSI key slot dimensions is shown on P113.

### Hardening of tooth heads

The teeth of a sprocket must be tough and wear resistant as they are impacted when engaged with the rollers of the chain and worn by sliding with the rollers. When severe wear and large shocks are anticipated, sprocket

made of carbon steel or cast steel should be used and high-frequency hardening should be conducted.









The standard sprockets DID40 to DID120 with a hub on only one side for single and double strand chains are induction-hardened even if the number of teeth is small. Whether the product is induction hardened or not is shown in the tables of dimensions of respective sprockets for your reference. Furthermore, in the following cases, induction-harden the teeth of the sprocket.

- The small sprocket has 20 or less teeth and is used at 1/6 or more of the maximum speed stated in the table of maximum kilowatt ratings.
- The small sprocket is used at a change gear ratio of 4:1 or more.
- The small sprocket is used for a low speed large load transmission as in cases of selection based on the "Low-speed selection".
- Sprockets are used in circumstances where the teeth are heavily worn.
- Sprockets are used under conditions where there are frequent starts and stops or sudden regular or reverse rotations.

### General cautions

For selecting the number of teeth and speed ration of the sprocket, see "How to select proper chain" (P120~123). For cautions for installing a sprocket on a shaft and replacement timing, see "Installation adjustment maintenance" (P127~137).

## Types, construction and materials

Type	Construction	Material
Flat plane (A type)	 Without hub. Standard specification does not include hardening of tooth heads.	Rolled steel for general structural purposes
Hub on one side only (B, BW type)	 Single  Double  Single  Double A sprocket with a hub on one side only. The standard hub diameter and hub length are set relative to the shaft diameter range used. Two structural types are available: integral structure (B type) and welded structure (BW type).	Carbon steel for machine structural purposes Cast steel Rolled steel for general structural purposes
Hubs on both sides (C type)	 Single  Single  Double  Double A sprocket with hubs on both sides. The standard hub diameter and hub length are set relative to the shaft diameter range used. Integral structure and welded structure types are available.	Carbon steel for machine structural purpose Cast steel

## Dimensions of Sprocket

Sprockets can be classified into standard sprockets, HK sprockets and other sprockets.

### 1. Standard sprocket

Standard sprockets are ANSI sprockets which can be engaged with standard series roller chains. See P125 for dimensions.

There are two types of tooth profiles: U-tooth and S-tooth. See P119 for tooth profile.

### 2. HK sprocket

HK sprockets can be engaged with HK series roller chains, and those for single strand chains are identical to standard sprockets. However, sprockets for multiple strand chains are different from standard sprockets in sprocket tooth profile. See the corresponding table in P117.

### 3. Other sprockets

Other sprockets are designed according to the following calculation formulas to suit respective specialty chains. Calculation results of sprocket tooth profiles of main sprockets are shown in the corresponding table on P117.

The sprockets used for the following chains are the same as the standard sprockets in tooth gap form, but different in tooth thickness (sprocket tooth profile).

Sprockets identical in tooth gap form (different in tooth thickness)

DID40=DID415, DID420  
 DID50=DID520, DID525  
 DID60=DID630

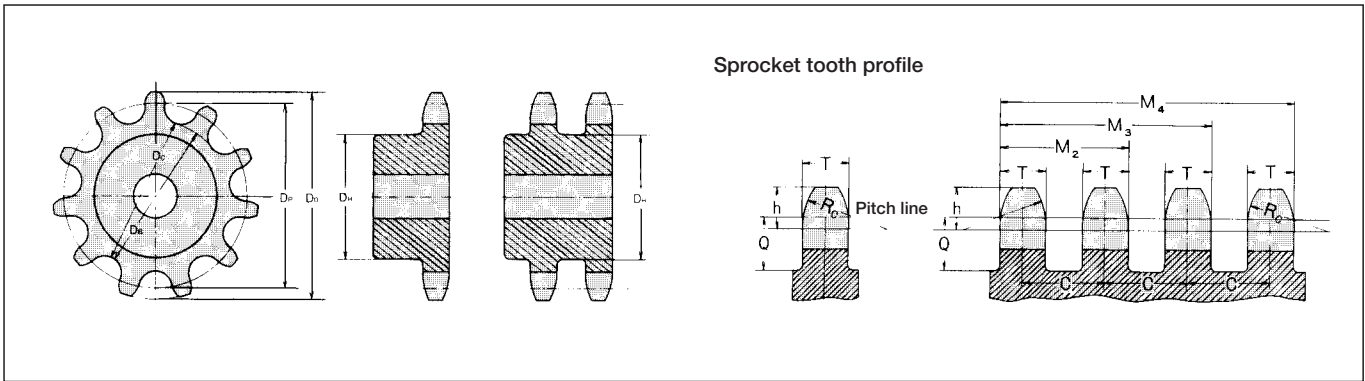

### 4. Calculation of sprocket dimensions

The dimensions of standard sprockets and other general sprockets are calculated as follows. At first, the diameters of sprockets are calculated from the following calculation formulas. Calculation formulas of tooth gap forms are shown on P118.

Next, sprocket tooth profile (the shape of the tooth depending on its thickness) is calculated from the following calculation formulas. (The values shown in the following pages were calculated by these formulas and regarded as the standard values.)

Calculation formulas of diameters (For simple calculation methods, see P124.)

Item	Formula
Pitch diameter (Dp)	$D_p = \frac{P}{\sin \frac{180^\circ}{N}}$ P: Chain pitch N: Number of sprocket teeth
Standard tip diameter (Do)	$D_o = P \left( 0.6 + \cot \frac{180^\circ}{N} \right)$
Root diameter (Db)	$D_b = D_p - D_r$ Dr: Roller outer diameter
Caliper diameter (Dc)	Even-numbered teeth $D_c = D_b$ Odd-numbered teeth $D_c = D_p \cos \frac{90^\circ}{N} - D_r$ $= P \frac{1}{2 \sin \frac{180^\circ}{2N}} - D_r$
Maximum hub diameter and maximum groove diameter (Dh)	$D_h = P \left( \cot \frac{180^\circ}{N} - 1 \right) - 0.76$

Calculation formulas of sprocket tooth profile

Item	Formula
Tooth width (T)	Single strand $T = 0.93W - 0.15$ Double or triple strands $T = 0.90W - 0.15$ Four or more strands $T = 0.86W - 0.30$ W: Inner width of chain
Transverse pitch (C)	$C = W + (4.22 \times \text{Plate thickness})$
Total tooth width (M)	$M = C (\text{Number of chain rows} - 1) + T$
Tooth face radius (Rc)	$R_c \approx 1.063P$ (Minimum value)
Center position of Rc (h)	$h \approx 0.5P$ P: Chain pitch
Depth of face (groove) from pitch line to maximum hub diameter (Q)	$Q \approx 0.5P$

### Standard sprocket tooth profile Unit (mm)

Sprocket No.	Dimensions of simplex and multiplex sprocket											
	Center position of Rc h	Radius of tooth form (Min.) Rc	Depth of slot Q	Transverse pitch C	Tooth width (Max.) T			Total tooth width				
					Simplex	Duplex/Triplex	Multiplex	M2	M3	M4	M5	M6
<b>DID 25</b>	3.2	6.8	3.5	6.4	2.8	2.7	2.4	9.1	15.5	21.6	28.0	34.4
<b>DID 35</b>	4.8	10.2	5.2	10.1	4.3	4.1	3.8	14.2	24.3	34.1	44.2	54.3
<b>DID 41</b>	6.4	13.5	7.0	—	5.8	—	—	—	—	—	—	—
<b>DID 40</b>	6.4	13.5	7.0	14.4	7.2	7.0	6.5	21.4	35.8	49.7	64.1	78.5
<b>DID 50</b>	7.9	16.9	8.8	18.1	8.7	8.4	7.9	26.5	44.6	62.2	80.3	98.4
<b>DID 60</b>	9.5	20.3	10.6	22.8	11.7	11.3	10.6	34.1	56.9	79.0	101.8	124.6
<b>DID 80</b>	12.7	27.0	14.1	29.3	14.6	14.1	13.3	43.4	72.7	101.2	130.5	159.8
<b>DID 100</b>	15.9	33.8	17.6	35.8	17.6	17.0	16.1	52.8	88.6	123.5	159.3	195.1
<b>DID 120</b>	19.1	40.5	21.1	45.4	23.5	22.7	21.5	68.1	113.5	157.7	203.1	248.5
<b>DID 140</b>	22.2	47.3	24.7	48.9	23.5	22.7	21.5	71.6	120.5	168.2	217.1	266.0
<b>DID 160</b>	25.4	54.0	28.2	58.5	29.4	28.4	27.0	86.9	145.4	202.5	261.0	319.5
<b>DID 180</b>	28.6	60.8	31.7	65.8	33.1	32.0	—	97.8	163.6	—	—	—
<b>DID 200</b>	31.8	67.5	35.2	71.6	35.3	34.1	32.5	105.7	177.3	247.3	318.9	390.5
<b>DID 240</b>	38.1	81.0	42.3	87.8	44.1	42.7	40.7	130.5	218.3	304.1	391.9	479.7

### Other sprocket tooth profile Unit (mm)

Sprocket No.	Dimensions of simplex and multiplex sprocket							
	Center position of Rc h	Radius of tooth form (Min.) Rc	Depth of slot Q	Transverse pitch C	Tooth width (Max.) T		Total tooth width	
					Simplex	Duplex/Triplex	M2	M3
<b>DID 15</b>	0.5	×20°	2.6	—	2.0	—	—	—
<b>DID 06B</b>	4.2	9.5	5.0	10.24	5.3	5.2	15.44	25.68
<b>DID 083</b>	6.4	13.5	7.0	—	4.5	—	—	—
<b>DID 415</b>	6.4	13.5	7.0	—	4.3	—	—	—
<b>DID 420</b>	6.4	13.5	7.0	—	5.8	—	—	—
<b>DID 428</b>	6.4	13.5	7.0	—	7.2	—	—	—
<b>DID 520</b>	7.9	16.9	8.8	—	5.8	—	—	—
<b>DID 525</b>	7.9	16.9	8.8	—	7.2	—	—	—
<b>DID 630</b>	9.5	20.3	10.6	—	8.7	—	—	—
<b>DID 635</b>	9.5	20.3	10.6	—	10.1	—	—	—

### HK type sprocket tooth profile Unit (mm)

Sprocket No.	Dimensions of simplex and multiplex sprocket							
	Center position of Rc h	Radius of tooth form (Min.) Rc	Depth of slot Q	Transverse pitch C	Tooth width (Max.) T		Total tooth width	
					Simplex	Duplex/Triplex	M2	M3
<b>DID 25H</b>	3.2	6.8	3.5	—	2.8	—	—	—
<b>DID 35HK</b>	4.8	10.2	5.2	—	4.3	—	—	—
<b>DID 40HK</b>	6.4	13.5	7.0	—	7.2	—	—	—
<b>DID 50HK</b>	7.9	16.9	8.8	—	8.7	—	—	—
<b>DID 60HK</b>	9.5	20.3	10.6	—	11.7	—	—	—
<b>DID 80HK</b>	12.7	27.0	14.1	32.6	14.6	14.1	46.7	79.3
<b>DID 100HK</b>	15.9	33.8	17.6	39.1	17.6	17.0	56.1	95.2
<b>DID 120HK</b>	19.1	40.5	21.1	48.9	23.5	22.7	71.6	120.5
<b>DID 140HK</b>	22.2	47.3	24.7	52.2	23.5	22.7	74.9	127.1
<b>DID 160HK</b>	25.4	54.0	28.2	61.9	29.4	28.4	90.3	152.2
<b>DID 180HK</b>	28.6	60.8	31.7	69.2	33.1	32.0	101.2	170.4
<b>DID 200HK</b>	31.8	67.5	35.2	78.3	35.3	34.1	112.4	190.7
<b>DID 240HK</b>	38.1	81.0	42.3	101.2	44.1	42.7	143.9	245.1

## Calculation formulas for diameters and tooth gap forms

### Calculation formulas for diameters

Calculation of pitch diameter, tip diameter and caliper diameter

The basic dimensions of a sprocket suitable for a chain pitch of 1 mm are respectively called pitch diameter factor, tip diameter factor and caliper diameter factor.

The respective factors for respective numbers of teeth are listed below. If these factors are multiplied by chain pitch, the basic dimensions of the corresponding sprocket can be obtained.

Example:

In the case of DID80 (25.40 mm pitch) with 35 teeth

Pitch diameter (Dp)

$$= P \times \text{Pitch diameter factor} \\ = 25.40 \times 11.1558 \doteq 283.36$$

Tip diameter (Do)

$$= P \times \text{Pitch diameter factor} \\ = 25.40 \times 11.711 \doteq 297$$

Root diameter (DB)

$$= \text{Pitch diameter (Dp)} - \text{Roller diameter (Dr)} \\ = 283.36 - 15.88 = 267.48$$

Caliper diameter factor (Dc)

$$= P \times \text{Caliper diameter factor} - \text{Roller diameter (Dr)} \\ = 25.40 \times 11.1446 - 15.88 \doteq 267.19$$

Note: Above sign ( $\doteq$ ) means approximate value.

Number of teeth	Pitch dia. factor	Tip dia. factor	Caliper dia. factor	Number of teeth	Pitch dia. factor	Tip dia. factor	Caliper dia. factor	Number of teeth	Pitch dia. factor	Tip dia. factor	Caliper dia. factor	Number of teeth	Pitch dia. factor	Tip dia. factor	Caliper dia. factor
11	3.5495	4.006	3.5133	39	12.4275	12.987	12.4174	67	21.3346	21.911	21.3287	95	30.2449	30.828	30.2408
12	3.8637	4.332	—	40	12.7455	13.306	—	68	21.6528	22.230	—	96	30.5632	31.147	—
13	4.1786	4.657	4.1481	41	13.0635	13.625	13.0539	69	21.9710	22.548	21.9653	97	30.8815	31.465	30.8774
14	4.4940	4.981	—	42	13.3815	13.944	—	70	22.2892	22.867	—	98	31.1997	31.784	—
15	4.8097	5.304	4.7834	43	13.6995	14.263	13.6902	71	22.6074	23.185	22.6018	99	31.5180	32.102	31.5140
16	5.1258	5.627	—	44	14.0175	14.582	—	72	22.9256	23.504	—	100	31.8362	32.421	—
17	5.4422	5.949	5.4190	45	14.3356	14.901	14.3269	73	23.2438	23.822	23.2384	101	32.1545	32.739	32.1506
18	5.7588	6.271	—	46	14.6536	15.219	—	74	23.5620	24.141	—	102	32.4727	33.057	—
19	6.0755	6.593	6.0543	47	14.9717	15.538	14.9634	75	23.8802	24.459	23.8750	103	32.7910	33.376	32.7872
20	6.3925	6.914	—	48	15.2898	15.857	—	76	24.1984	24.778	—	104	33.1093	33.694	—
21	6.7095	7.235	6.6907	49	15.6079	16.176	15.5999	77	24.5167	25.096	24.5116	105	33.4275	34.013	33.4238
22	7.0267	7.555	—	50	15.9260	16.495	—	78	24.8349	25.415	—	106	33.7458	34.331	—
23	7.3439	7.876	7.3268	51	16.2441	16.813	16.2364	79	25.1531	25.733	25.1481	107	34.0641	34.649	34.0604
24	7.6613	8.196	—	52	16.5622	17.132	—	80	25.4713	26.052	—	108	34.3823	34.968	—
25	7.9787	8.516	7.9630	53	16.8803	17.451	16.8729	81	25.7896	26.370	25.7847	109	34.7006	35.286	34.6970
26	8.2962	8.836	—	54	17.1984	17.769	—	82	26.1078	26.689	—	110	35.0188	35.605	—
27	8.6138	9.156	8.5992	55	17.5166	18.088	17.5094	83	26.4261	27.007	26.4213	111	35.3371	35.923	35.3336
28	8.9314	9.475	—	56	17.8347	18.407	—	84	26.7443	27.326	—	112	35.6554	36.241	—
29	9.2491	9.795	9.2355	57	18.1529	18.725	18.1460	85	27.0625	27.644	27.0580	113	35.9737	36.560	35.9702
30	9.5668	10.114	—	58	18.4710	19.044	—	86	27.3807	27.962	—	114	36.2919	36.878	—
31	9.8845	10.434	9.8718	59	18.7892	19.363	18.7825	87	27.6990	28.281	27.6945	115	36.6102	37.197	36.6068
32	10.2023	10.753	—	60	19.1073	19.681	—	88	28.0172	28.599	—	116	36.9285	37.515	—
33	10.5201	11.073	10.5082	61	19.4255	20.000	19.4190	89	28.3355	28.918	28.3310	117	37.2467	37.833	37.2434
34	10.8380	11.392	—	62	19.7437	20.318	—	90	28.6537	29.236	—	118	37.5650	38.152	—
35	11.1558	11.711	11.1446	63	20.0618	20.637	20.0556	91	28.9720	29.555	28.9676	119	37.8833	38.470	37.8800
36	11.4737	12.030	—	64	20.3800	20.956	—	92	29.2902	29.873	—	120	38.2016	38.788	—
37	11.7916	12.349	11.7810	65	20.6982	21.274	20.6922	93	29.6085	30.192	29.6042				
38	12.1096	12.668	—	66	21.0164	21.593	—	94	29.9267	30.510	—				

### Calculation formulas for tooth gap forms

As the most rational tooth gap forms in which the pressure angle changes in response to the elongation of a smoothly rotated roller chain with the lapse of service time, ANSI specify two types of tooth profiles: U-type

and S-type. In general, S-type tooth profiles are adopted in accordance with ANSI, and our standard sprockets also have S-tooth profiles.

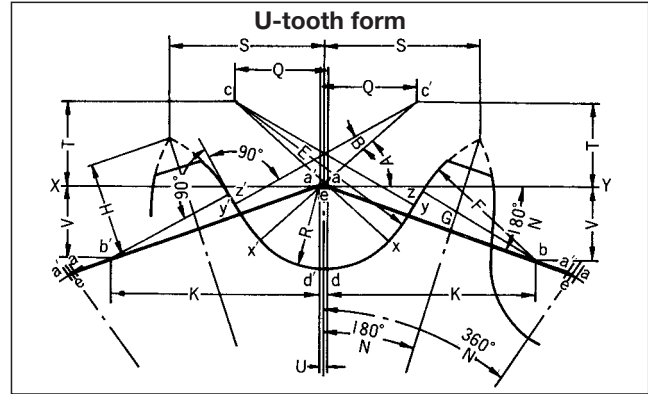
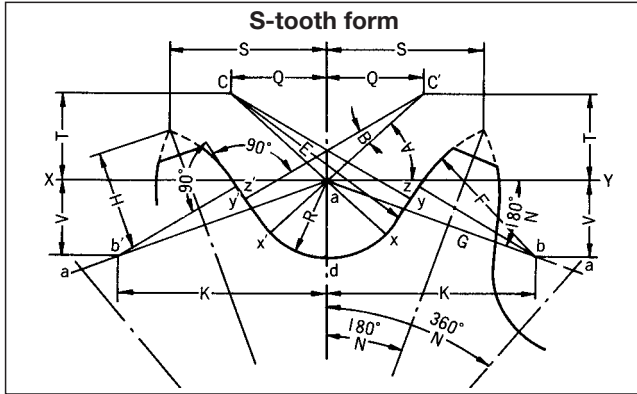

Item	Formula	Item	Formula
<b>Ds</b> (Tooth arc diameter)	$Ds = 2R = 1.055Dr + 0.076$ Dr: Roller diameter	<b>G</b>	$G = ab = 1.4Dr$ Point b is on the line drawn from point a on line xy at an angle of $180^\circ/N$ . (With U-tooth form, aa' is parallel to chordal pitch line e-e.)
<b>R</b>	$R = 0.5025Dr + 0.038$	<b>K</b>	$K = 1.4Dr \cos \frac{180^\circ}{N}$
<b>U</b> (Pitch clearance)	$U = 0.07 (P - Dr) + 0.051$ (S-tooth form: $U = 0$ ) P: Chain pitch	<b>V</b>	$V = 1.4Dr \sin \frac{180^\circ}{N}$
<b>A</b>	$A = 35^\circ + \frac{60^\circ}{N}$ N: Number of teeth	<b>F</b>	$F = Dr \left\{ 0.8 \cos \left( 18^\circ - \frac{56^\circ}{N} \right) + 1.4 \cos \left( 17^\circ - \frac{64^\circ}{N} \right) - 1.3025 \right\} - 0.038$
<b>B</b>	$B = 18^\circ - \frac{56^\circ}{N}$	<b>H</b>	$H = \sqrt{F^2 - \left( 1.4Dr - \frac{Pt}{2} + \frac{U}{2} \cos \frac{180^\circ}{N} \right)^2} + \frac{U}{2} \sin \frac{180^\circ}{N}$ $P_t =$ Chordal pitch equal to chain pitch $= P \left( 1 + \frac{Ds - Dr}{D_p} \right)$ (S-tooth form: a-a, U-tooth form: e-e)
<b>ac</b>	$ac = 0.8Dr$	<b>S</b>	$S = \frac{Pt}{2} \cos \frac{180^\circ}{N} + H \sin \frac{180^\circ}{N}$
<b>Q</b>	$Q = 0.8Dr \cos \left( 35^\circ + \frac{60^\circ}{N} \right)$	Approximate outer diameter of sprocket	Approximate outer diameter of sprocket $= Pt \left( 0.6 + \cot \frac{180^\circ}{N} \right)$
<b>T</b>	$T = 0.8Dr \sin \left( 35^\circ + \frac{60^\circ}{N} \right)$	Outer diameter of sprocket when sprocket tooth heads are sharp	Outer diameter of sprocket with sharp tooth head (at $J=H$ ) $= Pt \cot \frac{180^\circ}{N} + 2H$ (In this case, generally this formula is corrected to obtain the outer diameter.)
<b>E</b>	$E = cy = 1.3025Dr + 0.038$	Maximum pressure angle	Maximum pressure angle $= xab = 35^\circ - \frac{120^\circ}{N}$ (Pressure angle in the case of a new chain)
<b>xy</b>	$\overline{xy} = (2.605Dr + 0.076) \sin \left( 9^\circ - \frac{28^\circ}{N} \right)$	Minimum pressure angle	Minimum pressure angle $= xab - B = 17^\circ - \frac{64^\circ}{N}$
<b>yz</b>	$yz = Dr \left\{ 1.4 \sin \left( 17^\circ - \frac{64^\circ}{N} \right) - 0.8 \sin \left( 18^\circ - \frac{56^\circ}{N} \right) \right\}$	Average pressure angle	Average pressure angle $= 26^\circ - \frac{92^\circ}{N}$

1. The description in this chapter can be applied when a chain is endlessly engaged for transmission with two sprockets parallel in their shafts and accurate in alignment as illustrated below.

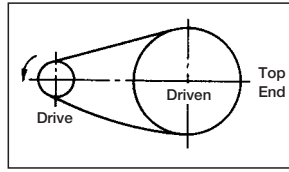

2. Consult us when a chain is to be used for lifting, pulling dollies or being engaged with a pin gear, etc.
3. When there are any regulations or guidelines concerning the selection of chains, select a chain in accordance with such regulations and the maximum kilowatt ratings (Drive performance) table described below, and choose the one with a larger allowance.

## How to Select the Proper Chain

The chain can be selected according to the following two methods:

- (1) Selection by drive performance
- (2) Low-speed selection

The drive performance method considers not only chain tension but also the shock load on the bushings and rollers due to the engagement between the sprockets and the chain, and the wear of pins, bushings and rollers.

The slow-speed method is applied when the chain is operated at a speed of 50 rpm or less. In general, the chain selected by this method is subject to conditions more severe than that selected according to the selection by drive performance. Thus, carefully assess the conditions when selecting with this method.

### Selection by drive performance

First, the following information is required.

- ① Power to be transmitted (kW)
- ② Speeds of driving shaft and driven shaft (speed ratio) and shaft diameters
- ③ Center distance between driving shaft and driven shaft

#### (a) Correction of power to be transmitted (kW)

Correction must be made to obtain the actual power to be transmitted as the level of load fluctuates depending on the machine and power source used, affecting the expected service life (for example, 15,000 hours in the case of capacities shown in the table of maximum kilowatt ratings). The service factor shown in Table 1 is an indicator of the load level. The power to be transmitted (kW) is multiplied by the corresponding service factor to obtain a corrected power.

$$\text{Corrected power (kW)} = \text{Power to be transmitted (kW)} \times \text{Service factor}$$

**Table 1. Service factor**

Type of load	Type of input power		
	Electric motor or turbine	Inner combustion engine	
		With multiple cylinders or hydraulic drive	Without multiple cylinders nor hydraulic drive
Smooth (agitator, centrifugal blower, feeder, textile machines, etc.)	1.0	1.0	1.2
Moderate shock (general work machines, compressors, machining tools, dryers, etc.)	1.3	1.2	1.4
Large shock (presses, civil engineering or mining machines, vibration machines, machines with reverse impact, etc.)	1.5	1.4	1.7

#### (b) Selection of chain size and the number of teeth of small sprocket

Use of simple selection chart

The number of teeth of small sprocket and the chain to be used are tentatively decided with reference to the simple selection chart (P122~P123) and the corrected power (P120~P121).

Using the table of maximum kilowatt ratings

If the results tentatively decided as described above are close to the design values, the number of teeth of small sprocket can be finalized with reference to the table of maximum kilowatt ratings. The maximum kilowatt ratings are established anticipating that an endless chain with 100 links has a life of 15,000 hours under the following conditions. (That is, the breaking of the chain and the loss of bushings and rollers do not occur at a wear elongation of 2 percent or less.)

- ① Operation is carried out in ambient temperature (-10°C~+60°C) free from dust and dust-containing liquid.
- ② There is no corrosive gas, or humidity, etc. to adversely affect the chain.
- ③ Proper lubrication is maintained.
- ④ The chain is used under conditions of a low start-stop frequency and a fairly stable load.

#### In the case of multiplex chain

Select a multiplex chain when the capacity of a simplex chain is insufficient. The maximum kilowatt rating of a multiplex chain cannot be obtained by multiplying the maximum kilowatt rating of a simplex chain by the number of multiplex chain since the loads are not evenly distributed between the strands. For the correction factor in this case, see the multiplex chain factor table. Our standard HI-PWR-S Roller Chains and HI-PWR-SHK Roller Chains are available up to triplex.

**Table 2. Multiplex chain factor**

Number of roller chain stand	Multiplex chain factor
2	1.7
3	2.5
4	3.3
5	3.9

$$\text{kW rating of multiplex chain} = \text{kW rating of simplex chain} \times \text{multiplex chain factor}$$



### Remarks for determining the number of teeth of small sprocket

When a chain of the minimum chain pitch required maximum kilowatt rating is selected, relatively silent and smooth transmission can be achieved, and the equipment can be compact.

However, considering smooth chain transmission, the wear of the chain and sprockets, etc., it is desirable that the sprocket have 15 or more teeth, and preferably an odd number. Avoid 12 teeth, 14 teeth and 16 teeth. When the sprocket has 12 or less teeth, the chain and sprocket heavily vibrate and are extremely worn, and transmission is not smooth. Likewise, avoid a small number of teeth as much as possible except in the case of low speed without shock.

### Shaft diameter

After the number of teeth of small sprocket is determined, multiply it by the speed ratio, and confirm whether the required shaft bore can be secured in reference to the maximum shaft bore in the table of sprocket dimensions. If the required shaft bore is larger than the maximum shaft bore, increase the number of teeth, or choose a one size larger chain.

### (c) Selection of the number of teeth of large sprocket

When the number of teeth of small sprocket is determined, multiply it by the speed ratio to determine the number of teeth of large sprocket.

In general, increasing the sprocket teeth number makes the chain bending angle smaller, which increases durability and enhances transmission efficiency. However, if the number of teeth is too large, slight elongation tends to cause the chain to ride over the sprocket, so keep the maximum number of teeth at 114 or less.

### Speed ratio

A speed ratio refers to the ratio of the speed of the driving shaft to the speed of the driven shaft, and usually a speed ratio of 7:1 or less is safe. If the speed ratio is larger than this ratio, the take-up angle of the chain on the small sprocket decreases, and chain jumping or abnormal wear of sprocket are likely to occur. If a large speed ratio is necessary, two-step speed change may be necessary.

## Low-speed selection

The low-speed selection method is used when the chain operation speed is 50 m/min or less and there is no worry of wear elongation and shock fracture of rollers and bushings.

In low-speed selection, the chain is selected in reference to the tensile fatigue strength of the chain. Therefore, a chain selected according to this method will be subject to more severe conditions than one selected according to the selection by drive performance method. When the Low-speed selection method is used, special care must be exercised. The Low-speed selection method cannot be used for the connecting links and offset links.

### (a) How to obtain corrected chain tension

$$\text{Corrected chain tension} = \left( \begin{array}{l} \text{Maximum tension acting} \\ \text{on chain kN (kgf)} \end{array} \right) \times (\text{service factor})$$

See Table 1 on the previous page. ←

To calculate the corrected chain tension, identify the exact maximum tension acting on the chain. The shock is considered to some extent in the service factor, but it is not absolute. Also consider the increase of tension by the inertia of equipment caused by starting and stopping.

### (b) Comparison with the maximum allowable tension of chain

Using the maximum allowable tension in the table of chain dimensions, sprocket tooth factor and rotating factor of the small sprocket listed below, obtain the corrected maximum allowable tension from the following formula:

$$\text{Corrected maximum allowable tension} = \left( \begin{array}{l} \text{Maximum allowable tension} \\ \text{See the table of chain dimensions} \end{array} \right) \times \left( \begin{array}{l} \text{Sprocket tooth factor} \\ \text{See Table 1.} \end{array} \right) \times \left( \begin{array}{l} \text{Rotating factor} \\ \text{See Table 2.} \end{array} \right)$$

If the corrected maximum allowable tension is larger than the corrected chain tension, you can select the chain.

For the number of teeth and speed of small sprocket not stated in Table 1 or 2, obtain the sprocket tooth factor and rotating factor by linear interpolation.

Table 1. Sprocket tooth factor

Number of tooth on small sprocket	Sprocket tooth factor <b>C<sub>NT</sub></b>
9 枚	0.903
11 枚	0.923
13 枚	0.939
15 枚	0.952
20 枚	0.978
23 枚	0.990
26T or larger	1.00

Table 2. Rotating factor

Small sprocket rpm	Rotating factor <b>C<sub>v</sub></b>
10 rpm or less	1.00
20 r/min	0.933
30 r/min	0.896
40 r/min	0.871
50 r/min	0.851
100 r/min	0.794
200 r/min	0.741

## Chart for chain selection DID standard roller chain

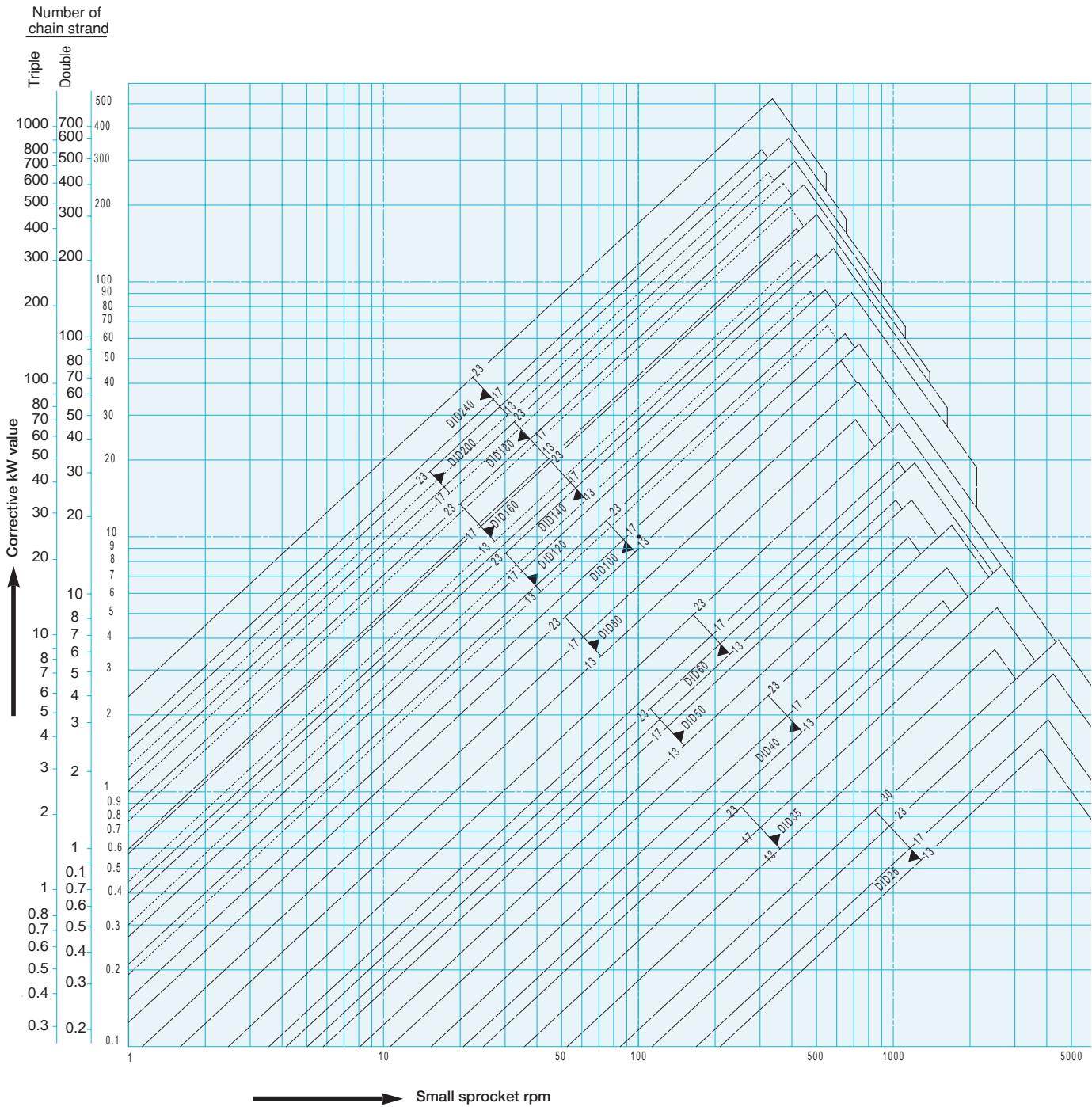

### (How to select a chain)

In the case that the corrective kW is 10kW and sprocket rpm is 100 rpm:  
the intersection of the corrective kW value (vertical axis) and the number of small sprocket tooth (horizontal axis) shows "DID100" for roller chain size and 17 for the number of the small sprocket teeth.

# Chart for chain selection DID -HI-PWR-S roller chain

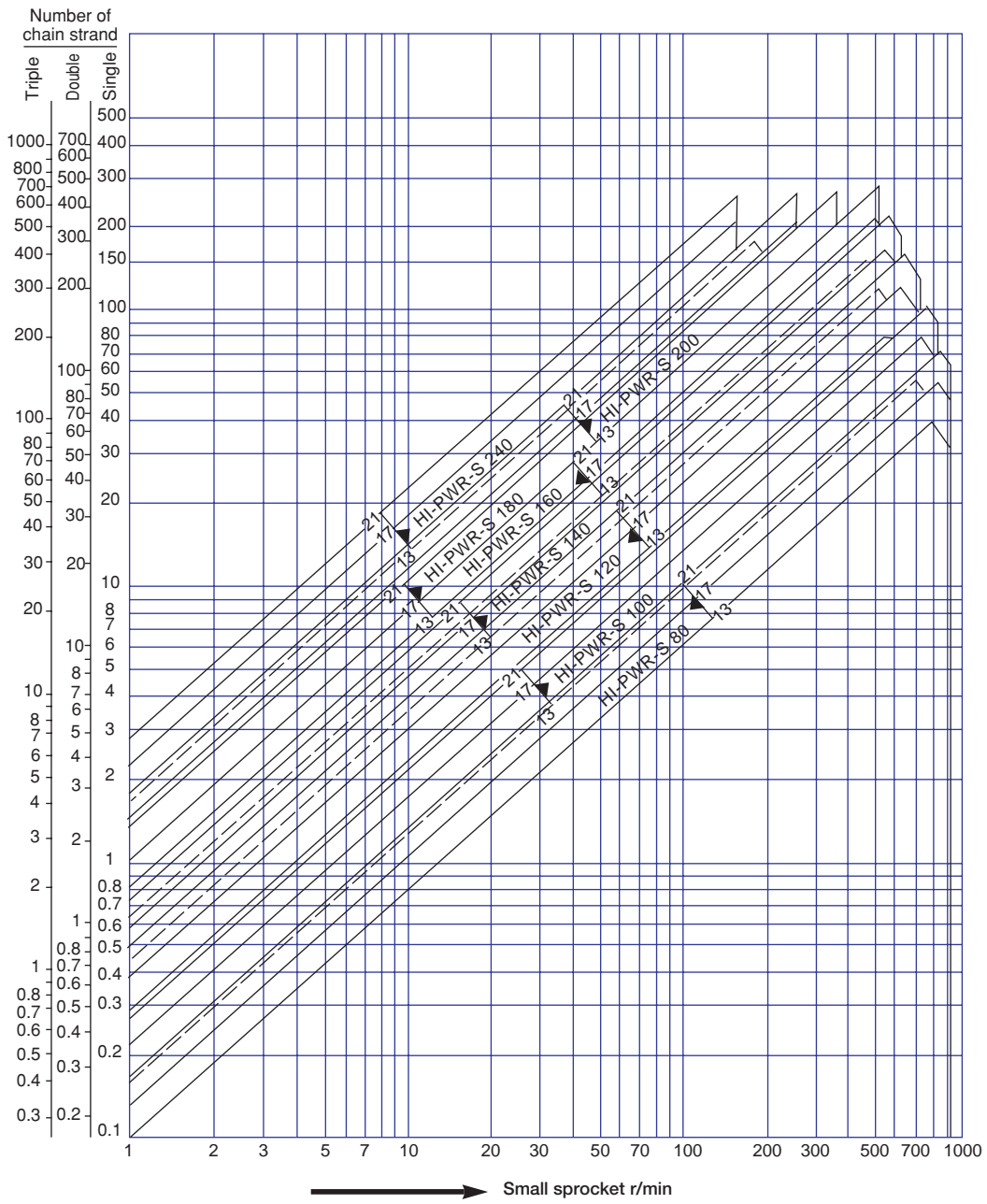

Please refer to P99 for how to use this chart.

## Chain Selection by Temperature

This is a chain selection method taking deterioration of strength in relation to temperature into consideration. Please use appropriate lubricant for the temperature at which the chain is to be used. Consult us for details.

### 1. Effects of temperature on the chains

#### 1.1 Effects of high temperature

- 1) Increased wear caused by decrease in hardness
- 2) Increased elongation caused by softening
- 3) Lubricant degradation, defective flexion caused by carbonization
- 4) Increase in wear and defective flexion caused by development of scales

#### 1.2 Effects of low temperature

- 1) Decrease in resistance to shock caused by low temperature brittleness.
- 2) Defective flexion caused by lubrication oil coagulation.
- 3) Defective flexion caused by adhesion of frost and ice.
- 4) Rusting caused by water-drops.

### 2. Kilowatt ratings according to temperature

Temperature	Roller Chain		Low Temperature resistance (TK)
	DID60 or smaller	DID80 or larger	
250°C and above	NA	NA	NA
200°C to less than 250°C	Catalog value×0.50	Catalog value×0.50	NA
150°C to less than 200°C	Catalog value×0.75	Catalog value×0.75	NA
80°C to less than 150°C	Catalog value	Catalog value	Catalog value (Max. allowable load at normal temperature)
-10°C to less than 80°C	Catalog value	Catalog value	Catalog value (Max. allowable load at normal temperature)
-30°C to less than -10°C	Catalog value×0.33	Catalog value×0.50	Catalog value (Max. allowable load at normal temperature×0.70)
-40°C to less than -30°C	Catalog value×0.25	Catalog value×0.33	Catalog value (Max. allowable load at normal temperature×0.58)
-50°C to less than -40°C	NA	Catalog value×0.25	Catalog value×0.46 (Max. allowable load at normal temperature×0.46)
-60°C to less than -50°C	NA	NA	Catalog value×0.41 (Max. allowable load at normal temperature×0.41)
-60°C or less	NA	NA	NA

※Please be aware that ambient temperature and the temperature of chains may differ.

### 3. Chain Selection according to Temperature

See slow-speed selection (p121) for use at extreme temperatures other than normal temperature.  
(Chain speed=50m/min or less)

### 4. Use of Stainless Steel Chains (SS, SSK) at high temperatures

Stainless steel chains (SS, SSK) can be used up to 400°C, but be aware that the ambient temperature and the chain temperature may differ. The strength of the chain decreases as the temperature rises. Especially at high temperatures, the higher the temperature rises, the chain will rupture by a lower load (creep rupture). In addition, defective flexion or defective chain revolution occurs due to heat expansion. In order to prevent such problems, adjust the clearance between chains. Consult us when using chains at 400°C or higher. Chains cannot be used at 700°C or higher.

# Chain Length and Sprocket Center Distance

## Required length of roller chain

Using the center distance between the sprocket shafts and the number of teeth of both sprockets, the chain length (pitch number) can be obtained from the following formula:

$$L_p = \frac{N_1 + N_2}{2} + 2 C_p + \frac{\{(N_2 - N_1) / 2\pi\}^2}{C_p}$$

- L<sub>p</sub> : Overall length of chain (Pitch number)
- N<sub>1</sub> : Number of teeth of small sprocket
- N<sub>2</sub> : Number of teeth of large sprocket
- C<sub>p</sub> : Center distance between two sprocket shafts (Chain pitch)

$\{(N_2 - N_1) / 2\pi\}^2$  can be obtained from the following table.

The L<sub>p</sub> (pitch number) obtained from the above formula hardly becomes an integer, and usually includes a decimal fraction. Round up the decimal to an integer. Use an offset link if the number is odd, but select an even number as much as possible.

When L<sub>p</sub> is determined, re-calculate the center distance between the driving shaft and driven shaft as described in the following paragraph. If the sprocket center distance cannot be altered, tighten the chain using an idler or chain tightener shown on P.126.

N <sub>2</sub> -N <sub>1</sub>	$\{(N_2 - N_1) / 2\pi\}^2$	N <sub>2</sub> -N <sub>1</sub>	$\{(N_2 - N_1) / 2\pi\}^2$	N <sub>2</sub> -N <sub>1</sub>	$\{(N_2 - N_1) / 2\pi\}^2$
1	0.03	35	31.03	69	120.60
2	0.10	36	32.83	70	124.12
3	0.23	37	34.68	71	127.69
4	0.41	38	36.58	72	131.31
5	0.63	39	38.53	73	134.99
6	0.91	40	40.53	74	138.71
7	1.24	41	42.58	75	142.48
8	1.62	42	44.68	76	146.31
9	2.05	43	46.84	77	150.18
10	2.53	44	49.04	78	154.11
11	3.07	45	51.29	79	158.09
12	3.65	46	53.60	80	162.12
13	4.28	47	55.96	81	166.19
14	4.97	48	58.36	82	170.32
15	5.70	49	60.82	83	174.50
16	6.49	50	63.33	84	178.73
17	7.32	51	65.88	85	183.01
18	8.21	52	68.49	86	187.34
19	9.14	53	71.15	87	191.72
20	10.13	54	73.86	88	196.16
21	11.17	55	76.62	89	200.64
22	12.26	56	79.44	90	205.17
23	13.40	57	82.30	91	209.76
24	14.59	58	85.21	92	214.40
25	15.83	59	88.18	93	219.08
26	17.12	60	91.19	94	223.82
27	18.47	61	94.25	95	228.61
28	19.86	62	97.37	96	233.44
29	21.30	63	100.54	97	238.33
30	22.80	64	103.75	98	243.27
31	24.34	65	107.02	99	248.26
32	25.94	66	110.34	100	253.30
33	27.59	67	113.71		
34	29.28	68	117.13		

## Center distance between driving and driven shafts

Obviously, the center distance between the driving and driven shafts must be more than the sum of the radius of both sprockets, but in general, a proper sprocket center distance is considered to be 30 to 50 times the chain pitch. However, if the load is pulsating, 20 times or less is proper. The take-up angle between the small sprocket and the chain must be 120°

or more. If the roller chain length L<sub>p</sub> is given, the center distance between the sprockets can be obtained from the following formula:

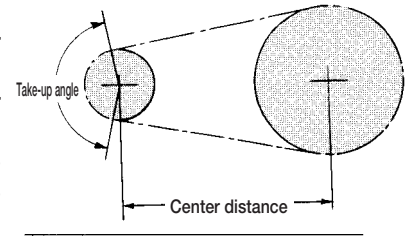

$$C_p = \frac{1}{4} \left\{ L_p - \frac{N_1 + N_2}{2} + \sqrt{\left( L_p - \frac{N_1 + N_2}{2} \right)^2 - \frac{2}{\pi^2} (N_2 - N_1)^2} \right\}$$

- C<sub>p</sub> : Sprocket center distance (pitch number)
- L<sub>p</sub> : Overall length of chain (pitch number)
- N<sub>1</sub> : Number of teeth of small sprocket
- N<sub>2</sub> : Number of teeth of large sprocket

$\frac{2}{\pi^2} (N_2 - N_1)^2$  can be obtained from the following table.

N <sub>2</sub> -N <sub>1</sub>	$\frac{2}{\pi^2} (N_2 - N_1)^2$	N <sub>2</sub> -N <sub>1</sub>	$\frac{2}{\pi^2} (N_2 - N_1)^2$	N <sub>2</sub> -N <sub>1</sub>	$\frac{2}{\pi^2} (N_2 - N_1)^2$
1	0.20	35	248.24	69	964.78
2	0.81	36	262.63	70	992.95
3	1.82	37	277.42	71	1021.52
4	3.24	38	292.62	72	1050.50
5	5.07	39	308.22	73	1079.88
6	7.30	40	324.23	74	1109.67
7	9.93	41	340.64	75	1139.87
8	12.97	42	357.46	76	1170.46
9	16.41	43	374.69	77	1201.47
10	20.26	44	392.32	78	1232.88
11	24.52	45	410.35	79	1264.69
12	29.18	46	428.79	80	1296.91
13	34.25	47	447.64	81	1329.54
14	39.72	48	466.89	82	1362.57
15	45.59	49	486.55	83	1396.01
16	51.88	50	506.61	84	1429.85
17	58.56	51	527.07	85	1464.09
18	65.66	52	547.95	86	1498.74
19	73.15	53	569.22	87	1533.80
20	81.06	54	590.91	88	1569.27
21	89.37	55	612.99	89	1605.13
22	98.08	56	635.49	90	1641.41
23	107.20	57	658.39	91	1678.08
24	116.72	58	681.69	92	1715.17
25	126.65	59	705.40	93	1752.66
26	136.99	60	729.51	94	1790.55
27	147.73	61	754.03	95	1828.85
28	158.87	62	778.96	96	1867.55
29	170.42	63	804.29	97	1906.66
30	182.38	64	830.02	98	1946.18
31	194.74	65	856.17	99	1986.10
32	207.51	66	882.71	100	2026.43
33	220.68	67	909.66		
34	234.26	68	937.02		



## Layout

When a roller chain is used, shaft positions can be arbitrarily determined. However, in principle, follow the illustration shown below. That is, if the chain is tensioned horizontally, keep the top tensioned. Avoid vertical transmission whenever possible. In an inevitable case, place the large sprocket at the bottom regardless of the direction of rotation.

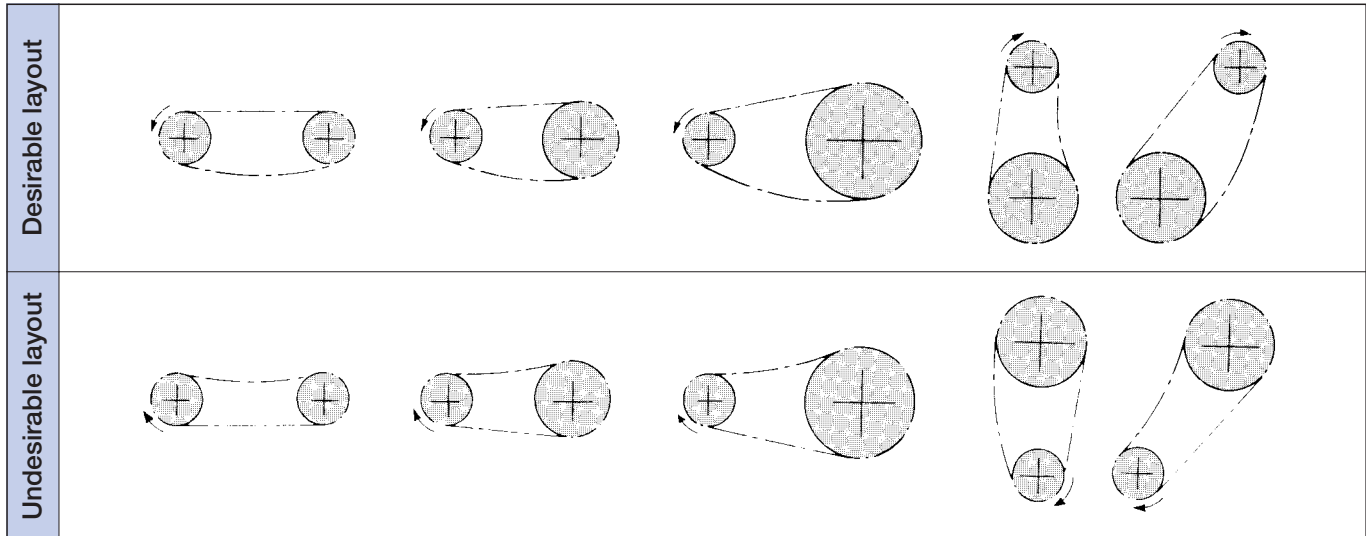

### When the chain layout is undesirable:

- When the top is sagging and the sprocket center distance is short:  
As illustrated below, adjust the sprocket center shaft to eliminate the sag.

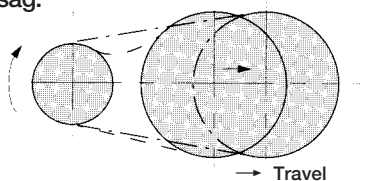

- When the top is sagging and the sprocket center distance is long:  
As illustrated below, install an idler from inside to eliminate the sag.

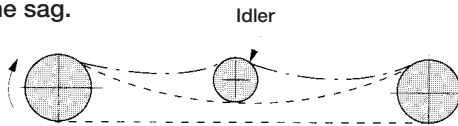

- When the chain is vertical or inclined:  
As illustrated below, eliminate the extra sag by a tensioner. In this case, a tensioner that automatically eliminates the sag gives better results.

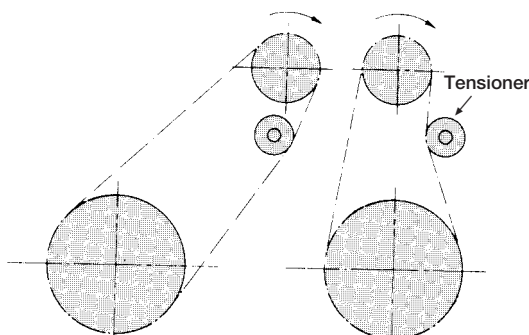

### When a pulsating load acts in high speed operation:

The chain's vibration and the load impact frequency or chordal action may synchronize to amplify vibration on the chain. Since vibration affects the chain, take countermeasures to prevent vibration in the following measures:

- Change the chain speed.
- Increase chain tension. However, note that over-tensioning can shorten the life of the chain.
- Use an idler or tensioner to divide the span.

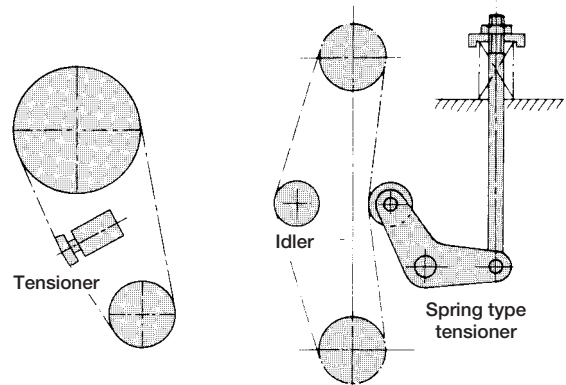

- Install a guide stopper to prevent vibration.

Note:  
Chordal action refers to the vertical motion of chain caused when it is engaged with sprockets.

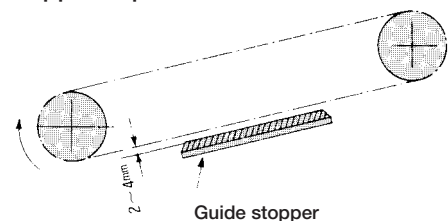



## Installation

### Installation of sprockets

For smooth transmission and extended life of the roller chain, it is important to correctly install proper sprockets. Use the following installation procedure.

1. Properly install a sprocket on a shaft, and fix it with a key to prevent it from rattling during operation. Also, place the sprocket as close as possible to the bearing.

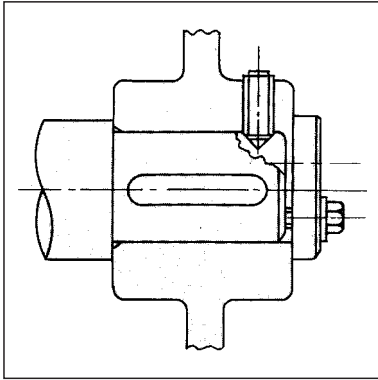

2. Adjust the shaft levelness to  $\pm 1/300$  or less using a level.

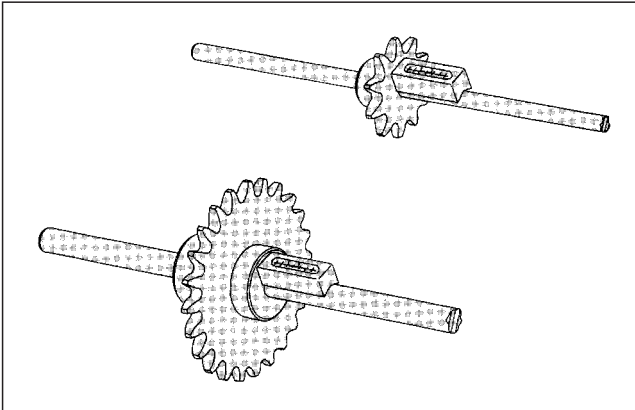

3. Adjust the shaft parallelism ( $\frac{A-B}{L}$ ) to  $\pm 1/300$  or less.

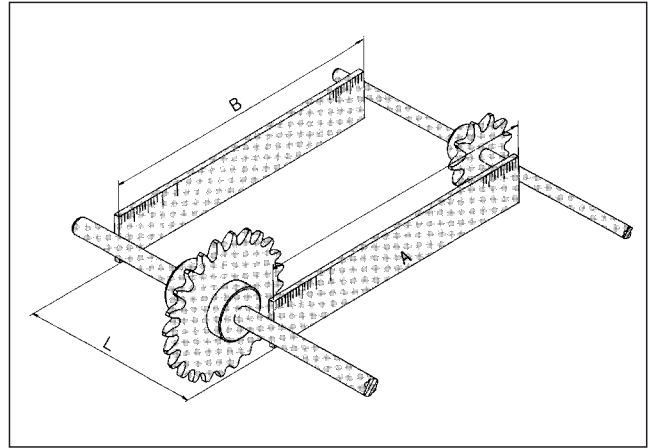

4. Adjust the level of driving and driven sprockets using a linear scale. (Also adjust the idler and the sprockets, or the tensioner and the sprockets in the same way.)

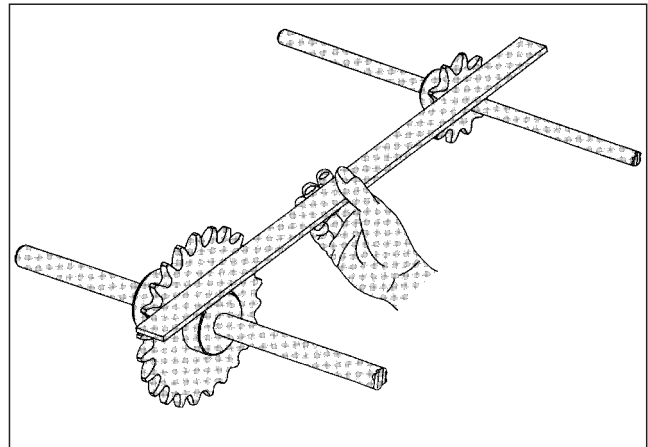

Keep the allowance  $\delta$  in the range specified below.

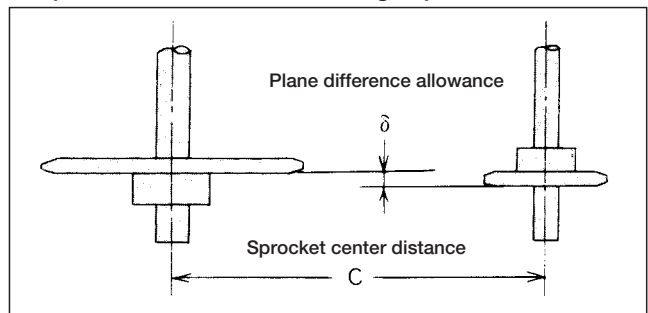

Sprocket center distance C	Allowance $\delta$ (mm)
1m or less	$\pm 1$
1m~10m	$\pm C$ (mm) / 1000
10m or more	$\pm 10$

## Installation of roller chain

When connecting a roller chain with the sprockets, observe the following procedure. When the connecting link is not well lubricated, apply sufficient grease.

### When using the sprocket teeth

1. Engage the chain with the sprockets so that both ends of the chain are on one of the sprockets, as shown in the following photo.
2. Insert connecting pins at the joint.
3. Fit a connecting plate, and fasten by a spring clip or cotters.



Pay extra attention not to damage the tooth heads of the sprocket.

### When using tools

#### Cautions

1. When a connecting plate is fastened by a spring clip, apply the spring clip to the pin grooves of the connecting pins as illustrated below, and lock it using pliers, etc. As for the direction of spring clip insertion, keep the opening of the spring clip turned in the direction opposite to the direction of chain rotation, as illustrated below.

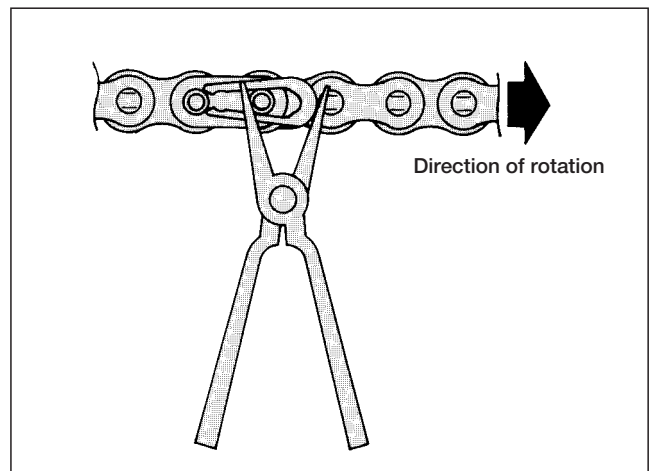

2. In circumstances where the sprocket center distance can hardly be adjusted, an odd number of links may be used. However, add one link, to use an even number of links and eliminate the sag by shifting a sprocket or installing an idler.
3. When an H-connecting link is used, pins must be driven into the connecting plate because of interference. In this case, ensure that the pair of pins are kept parallel to each other when inserted into the connecting plate. Never make the holes of the connecting plate larger or make the pins thinner for easier connection work. This applies also when a cotter type outer link (CP) is used instead of a connecting link.

## How to connect O-ring Chains

### Remarks to connect general O-ring Chains:

1. A connecting link of an O-ring Chain for general application is pre-coated with grease at the pins. Before connection, confirm the grease on the surfaces of pins, and if the amount of grease is small, apply grease with bare hands. (If gloves are used, the grease will be absorbed by the gloves.)

Example: When the connecting link (I) of an O-ring chain for general application is shipped, O-rings are fitted at the roots of the pins. If the O-rings come loose due to vibration during transport, refit the O-rings in to the roots of the pins.

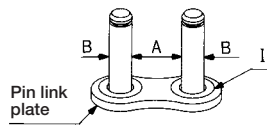

In this case, be sure to return the grease collected at the roots of the pins to the central surfaces of the pins, more at portion A than at portions B shown in the above illustration. (Portions A is worn because of sliding with the bushings.)

2. The chain can be most easily connected on the teeth of a sprocket. Engage the links at both ends of the chain with the sprocket teeth and fit connecting pins. If the sprocket can be moved, the chain can also be connected on the loosened side.

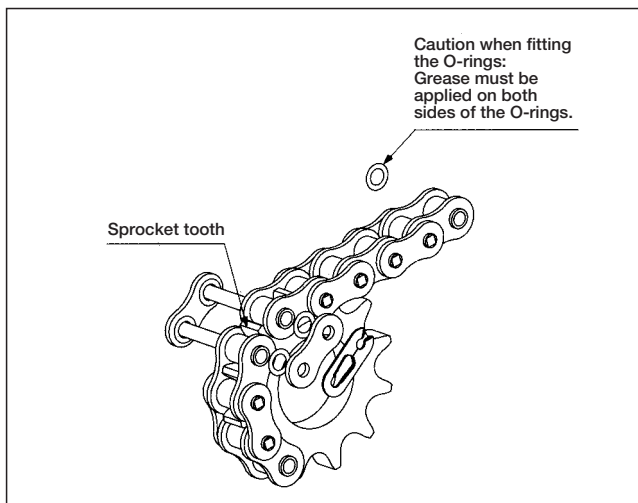

3. Connecting procedure

- ① Confirm that O-rings are attached to the roots of the pins.
- ② If the amount of grease applied on the connecting pins is small, coat the pins with grease at the central portions.
- ③ Insert the connecting pins into the bushings of the inner links at both ends.
- ④ Confirm that the grease is applied to the entire face of the O-ring, and fit the O-ring onto the connecting pins.
- ⑤ Insert the connecting pins into the connecting plate and while pressing the connecting plate, install the spring clip. Confirm whether the head (the end without a split) of the spring clip is turned in the feeding direction of the chain. (See the following illustration.)
- ⑥ Be sure to confirm that the spring clip is securely fitted in the clip grooves of the connecting pins.

This completes jointing of the connecting link. Note that grease on the surfaces of connecting pins and O-rings can be removed during installation work. In this case, re-grease using the grease on the surface of the base chain or the grease in the polyethylene bag in which the connecting link was contained.

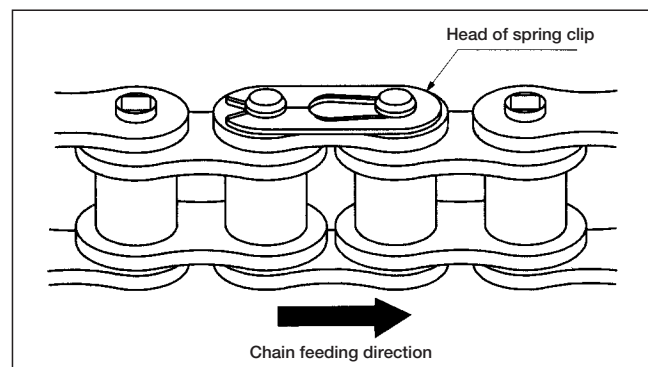

## Maintenance

### Check

#### a. Confirm the following before operation

Connected joint	<ul style="list-style-type: none"> <li>Confirm that the connection is sufficient and that components have no problem.</li> <li>Confirm that bending is smooth (in the case of O-ring chain, bending is slightly stiff).</li> </ul>
Chain sprocket attachment	<ul style="list-style-type: none"> <li>Confirm that there is no serious flaw, rust or wear.</li> <li>Confirm that sag is proper.</li> <li>Confirm that no pin rotates.</li> <li>Confirm that rollers rotate smoothly.</li> <li>Confirm that the chain engages with the teeth of sprockets.</li> </ul>
Interference	<ul style="list-style-type: none"> <li>Confirm that there is nothing interfering with the chain, or that nothing is likely to interfere with the chain or safety cover.</li> </ul>
Lubrication	<ul style="list-style-type: none"> <li>Confirm that the amount of lubrication is appropriate. (For the amount of lubrication, see the table of lubrication types.)</li> </ul>
Driving and driven shafts	<ul style="list-style-type: none"> <li>Confirm that the axial measurement and parallel measurement are proper.</li> <li>Confirm that the difference of sprocket planes is within the allowance.</li> </ul>
Peripheral equipment	<ul style="list-style-type: none"> <li>Confirm that peripheral equipment is installed correctly.</li> </ul>

#### b. After confirmation and adjustment of the above a, install the safety cover, and switch on the power to start operation.

- It is possible for the chain to be thrown should it break. Do not stay in the direction of rotation during operation.



### Caution

- |                                |  |
|--------------------------------|--|
| Obstacles                      | <ul style="list-style-type: none"> <li>Obstacles may cause breaking or fracturing which can scatter materials and injure people nearby. Be sure to remove all obstacles.</li> </ul>  |
| Abnormal noise                 | <ul style="list-style-type: none"> <li>Abnormal noise during operation is a sign of trouble. Immediately switch off the power, and determine the cause.</li> </ul>   |
| Flaws and rust                 | <ul style="list-style-type: none"> <li>If any serious flaws or rust is visible, it may cause the chain to break and fracture and possibly injure people nearby. Confirm that the chain has no serious flaws or rust.</li> </ul>  |
| Sprocket                       | <ul style="list-style-type: none"> <li>If a sprocket is worn, the sprocket may break, or the chain may ride over the sprocket, breaking it and possibly resulting in injury to people nearby. Confirm that the sprockets are not worn.</li> </ul>  |
| Devices that prevent accidents | <ul style="list-style-type: none"> <li>Install accident prevention devices. To avoid human injury caused by scattered materials, install safety devices (safety cover, safety net, etc.).</li> <li>Install an emergency stop device. To avoid human injury due to unexpected overload, install an emergency shutdown device such as a load controller or a brake.</li> </ul> |

### Before trial operation

Confirm the following on chain installation before starting operation.

- The chain correctly engages with the sprockets.
- The joints are normal. (The spring clips are correctly installed and cotters are not bent.)
- The chain sag is proper.
- The chain is not in contact with the chain case.
- The lubrication is proper.

### Check items during trial operation

If the chain can be manually rotated, rotate it to confirm that there is no abnormality before starting trial operation.

Be alert to the following during trial operation.

- Whether there is abnormal noise. If the chain contacts the chain case or if the chain heavily vibrates, abnormal noise occurs. Check the installation of chain case and chain sag.
- Whether lubrication is normal during operation. Re-check the condition of lubrication.

### Elongation limit of chain Limit of Chain Sag

- Events caused by sag failure

Even if the sag of the chain is normal before the start of operation, it can increase if the chain is elongated due to

wear of pins, bushings, etc. If the sag is excessive, the following will occur.

- Abnormal vibration
- Chain rollers ride over the heads of sprocket teeth.
- The chain is seized by a sprocket.
- The chain contacts the chain case.

These conditions can often cause abnormal noise. Should any abnormal noise occur, immediately stop operation, and check carefully to determine the cause. Such conditions often cause damage not only to the chains, but to the entire equipment. A preliminary check is necessary.

#### • Elongation limit of chain

Even if sag adjustment is normal, excessive elongation of the chain can cause abnormalities similar to those caused by sag failure that inhibit smooth transmission. In such cases, replace the chain. A guide for replacement based on chain elongation limit is listed below. Even if only one link reaches the elongation limit, replace the entire chain with a new one. Unless lubrication is normal, the chain will elongate quickly, causing the aforementioned troubles. Read the contents of "Lubrication" in the next section carefully for performing proper maintenance.

### Elongation limits of chain

Number of teeth of large sprocket	Regular chain	O-ring chain and Sintered bushing roller chain
40 or less	2.0%	1.0%
41~60	1.5	1.0
61~80	1.2	1.0
81~100	1.0	1.0
101 or more	0.8	0.8

※ If elongation of an O-ring chain or Sintered bushing roller chain exceeds the value in the above table, the wear rate of the chain becomes equivalent to a standard chain, and chain wear rapidly increases from that point.

※ The above elongation limits are applicable when the chain can be taken up or when a sag adjusting device is installed. If the shafts are fixed without any sag adjusting device, the recommended elongation limit is 0.5 to 0.7%.

#### • Elongation measuring method

- To eliminate rattling other than a slight amount of play in the chain as a whole, tighten the chain lightly and measure the elongation.

Note: For an accurate measurement, measure the elongation of the chain applying a measuring load (specified by ANSI) to the chain.

- As illustrated below, measure the inner length ( $L_1$ ) and the outer length ( $L_2$ ) and obtain the measured length ( $L$ ).

$$L = \frac{L_1 + L_2}{2}$$

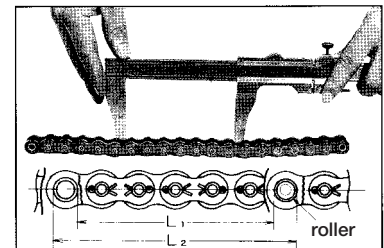

- Then, obtain chain elongation.

$$\text{Chain elongation} = \frac{\text{Measured length} - \text{Reference length}}{\text{Reference length}} \times 100(\%)$$

$$\text{Reference length} = \text{Chain pitch} \times \text{Number of links}$$

- In order to reduce the measuring gap, measure the length of about six to ten links.

### Chain wear-elongation check gage

We recommend and can supply a chain wear-elongation check gage (P.114) for facilitated finding of elongation limit.

## Sag adjustment of roller chain

To use a roller chain for a longer period of time, proper sag is an important component. If the roller chain is over-tensioned, the oil film between pins and bushings is lost, shortening chain life and damaging the bearings. If the chain sags overly, the chain will vibrate or be seized by the sprocket. In about 50 hours (it differs depending on the service conditions) after starting the roller chain use, the chain will be elongated by about 0.1 percent of the entire length due to the conformability of respective contacts. So, adjust the sag at this time. Thereafter, if proper lubrication is maintained, the elongation will be negligible. Check and adjust the sag at proper intervals.

### Optimum sag

In general, keep sag  $S$  at about 2 % of span  $L$ , but in the case described below, keep it at about 1 %.

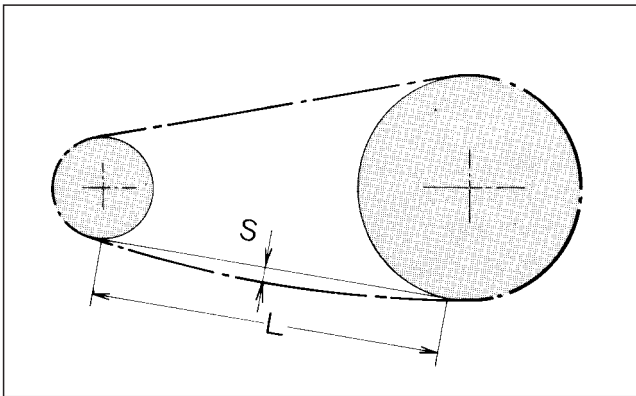

Keep sag at 0.01L or less in the following cases:

- When the chain is installed vertically or almost vertically.
- When the chain is installed horizontally or almost horizontally with the top slackened.
- When the center distance between sprockets exceeds 50 times the chain pitch.
- When vibration or shock occurs.
- When the chain is frequently started and stopped.
- When the chain is suddenly reversed.
- When the speed ratio is 7:1 or more (keeping the speed ratio at 7:1 or less is safer and preferable.)

## How to adjust sag

Adjust sag in the following ways.

### 1. Adjustment of the center distance

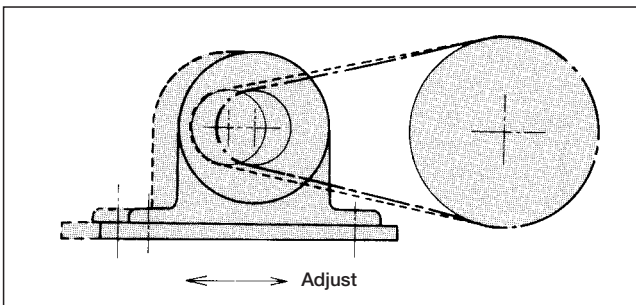

### 2. Adjustment using a tensioner or idler

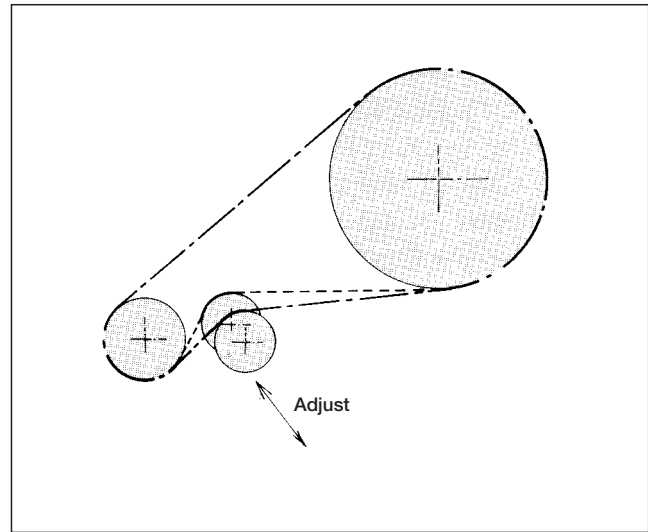

### 3. Increase or decrease of pitch number by offset link

By using an offset link, the total length of a chain can be increased or decreased by one pitch. However, since offset link performance is generally poor, an even number of links, if possible, is recommended.

## Other checks

### ● Checking sprocket

If a sprocket is not installed at the correct position of the shaft or is not parallel to the shaft, the plates of the chain may be flawed, or the chain may be twisted. This can be judged by examining the contact faces of the sprocket teeth. In this illustration, a uniform contact as indicated by A is normal. If the contact is different on both sides as indicated by B, correction is necessary.

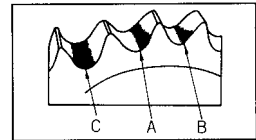

### ● Checking idler or tensioner

When sag is adjusted, check also whether the idler or tensioner itself is damaged. If the contact between an idler or tensioner and a chain is at the center of the tooth gap bottom as indicated by C, it is normal. If the contact is as indicated by A or B, the bearing of the idler or tensioner may be abnormal.

### ● Checking chain attachments

In the case of a chain with attachments, it can result in accidents if a mounted part is loosely installed or comes off. Furthermore, if an installation hole is enlarged due to wear, the chain life may be shortened.

For troubles during operation, see "Trouble Shooting".



## Lubrication

### Necessity of lubrication

In a roller chain transmission, even if the chain and sprockets are designed to suit the service conditions, poor lubrication inhibits maintaining performance and life to design specifications. In the case of a roller chain, the wear loss caused under proper lubrication is dramatically different from that caused without it. Troubles caused due to insufficient lubrication include the wear of pins and bushings, rough engagement with the sprockets, increased noise, and breakage as a result of prolonged undesirable conditions. Proper lubrication is very important. Requirements of lubrication and the effects of proper lubrication are listed below.

Requirements of lubrication	Effects of proper lubrication
<ul style="list-style-type: none"> <li>• Selection of lubricant</li> <li>• Lubricating points</li> <li>• Lubrication type (lubricating method, lubrication intervals, amount of lubrication)</li> </ul>	<ul style="list-style-type: none"> <li>• The wear of frictional portions is decreased.</li> <li>• Power loss is decreased.</li> <li>• Seizure is prevented.</li> <li>• Frictional heat is decreased.</li> <li>• Generated heat is eliminated.</li> <li>• Ensure smooth operation and extends machine life.</li> </ul>

### Selection of lubricant

Select the lubricant of a roller chain in reference to the lubrication type (P.133), ambient temperature and chain No., according to the following table.

Lubricant should be a mineral oil of good quality. It is important that the lubricant contains no dust or foreign substance. Never use waste oil. If the ambient temperature is extremely low (-10°C or lower) or high (+60°C or higher), a specific oil is necessary. In this case, please consult our engineering department.

Type of lubrication Chain No.	A, B				C			
	Atmospheric temperature				Atmospheric temperature			
	-10°C ~ 0°C	0°C ~ 40°C	40°C ~ 50°C	50°C ~ 60°C	-10°C ~ 0°C	0°C ~ 40°C	40°C ~ 50°C	50°C ~ 60°C
<b>DID 25~DID 50</b>	SAE10W	SAE20	SAE30	SAE40	SAE10W	SAE20	SAE30	SAE40
<b>DID 60~DID 80</b>	SAE20	SAE30	SAE40	SAE50				
<b>DID 100</b>					SAE20	SAE30	SAE40	SAE50
<b>DID 120~DID 240</b>	SAE30	SAE40	SAE50		SAE20	SAE30	SAE40	SAE50

Special kind of lubricant must be applied when ambient temperature is -10°C or lower or 60°C or higher. Please consult us for appropriate selection of lubricant.

### Lubricating points

If the chain is immersed in an oil bath, oil penetrates every part of the chain. In the case of manual lubrication, brush lubrication or drip lubrication, ensure that the oil sufficiently penetrates the portions of ① and ② in the following illustration.

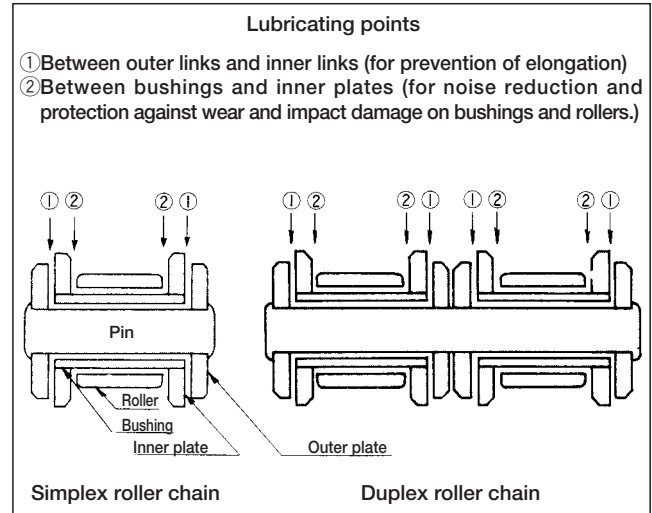

Lubricate on the sag side of the chain, i.e., at the position indicated in the following illustration. Since the lubricant is also useful for rust prevention, coating the entire surface of the chain with the oil is recommended.

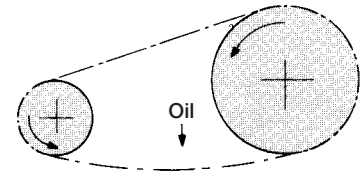



### Lubrication types (Explanation of A, B and C in the tables of Drive performance (kW ratings))

The allowable kilowatt ratings of chains shown in table of the drive performance (kW ratings) is based on the condition that any of the following lubrication is adopted. If any of the following lubrication cannot be adopted or in circumstances where earth, sand or dust exists, see the DID Ultimate Life Chain Series (see P.64).

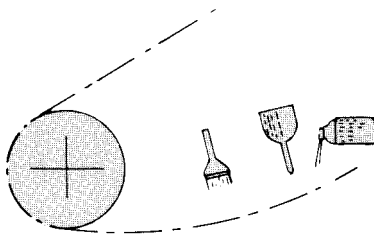
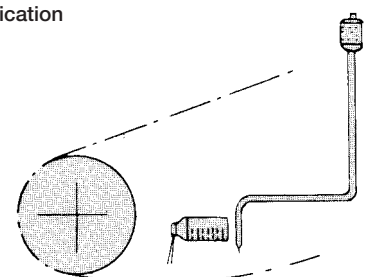
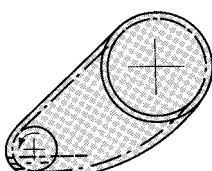
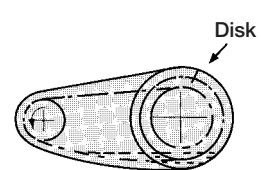
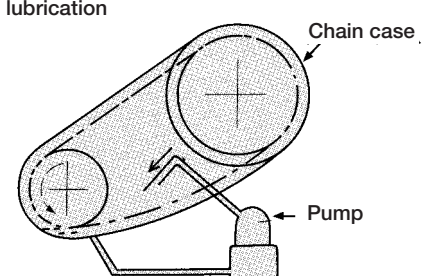
Lubrication type	Name and method	Lubrication intervals and amount	Caution
<b>A</b>  Use DID chain lube (see P.114).	Lubricator Brush  	Carry out periodical using a lubricator or brush at least once a day.	While rotating the chain slowly, lubricate the entire length uniformly three to four times. Take care not to allow your hand or clothes to be caught by the chain during lubrication. Note that extra oil will be scattered when the operation is started.
	Drip lubrication  	Supply about 5 to 20 drops of oil per minute.	In this case, since extra oil is scattered, installing a simple casing is recommended.
<b>B</b>	Oil bath lubrication  	Keep the chain immersed in oil, about 10 mm below the oil surface. If immersion is too deep, the oil will become abnormally hot.	The container should be leak proof. Before using the container for the first time, thoroughly wash the inside to remove dust and other foreign substance.
	Disk lubrication  	A disk is used to apply oil to the chain. Keep the disk immersed in oil, at a depth of about 20 mm. Keep the peripheral speed higher than 200 m/ min.	
<b>C</b>	Forced feed lubrication  	The amount of lubrication must be set to avoid abnormal heating. In general, the oil amount should be set at a level not to allow the chain high temperature over 60°C.	The oil container should be leak proof. When using the container for the first time, thoroughly wash the inside to remove all dust and foreign substance.

## General cautions for lubrication

Unless proper lubrication is carried out, chain fatigue will result earlier, causing various problems. Careful inspection is necessary.

### In the case of insufficient lubrication

If the lubricant is exhausted, red rust is generated between the inner and outer plates, causing wear drastically. When a chain is disassembled after going under such condition, red rust is visible on the surfaces of pins, and the surfaces are roughened, as shown in this photo. (Normally, pins have a mirror surface.) The lubricant must be applied before this happens.



### Do not use grease for lubrication !!

Do not use grease to lubricate your chains, since grease takes too long to reach the inside through pins and bushings at ambient temperature. Use the machine oil shown in the table on P.132 or DID Chain Lube/DID HI-PWR Lube (a spray lubricant).

Before lubrication, remove foreign substances and dirt from the chain as thoroughly as possible. If water is used for washing the chain, quickly dry it to prevent rusting, and then lubricate.

### In the case of drip lubrication, oil bath lubrication or forced feed lubrication

Check the following:

1. The lubricant is not dirty.
2. The amount of lubricant is correct.
3. Lubricant is uniformly applied to the chain.

### Cautions

Dust contamination must be avoided to maintain wear resistance. If temperature rises abnormally or the chain squeaks, the oil may be exhausted. Check to verify the condition.

## Troubleshooting Guide

Trouble	Possible cause	Correction
A pin, bushing or roller is fractured.  Note: See "Fracture patterns of respective chain components" on P.136.	High speed revolution exceeding the tolerance of chain and sprockets	Decelerate the speed, or select a chain with a smaller pitch. Otherwise, select a sprocket with a larger number of teeth. Refer to the details of "Selection by Drive Performance (kilowatt ratings)" (P.120).
	Sudden large shock load	Avoid shock load as much as possible. Install a damper, etc., to damp the shock load.
	Improper lubrication	Periodically supply the correct lubricant. Spray type chain oil "DID Chain Lube" is recommended.
	Corrosion of chain	Check the service circumstances and lubrication condition, and select a proper chain.
	Wear of sprocket	Replace it with a new one. Use a sprocket conforming to the correct standard dimensions.
Abnormal noise	Seized foreign substances	Immediately remove the foreign substances, and strictly control the service circumstances.
	Chain is excessively tensioned or sagged.	Pay constant attention to the chain sag. Correct by adjusting it according to the procedure stated in "Sag adjustment of roller chain" (P.131).
	Incorrect alignment of sprockets	Check the alignment between both the large and small sprockets.
	Large wear elongation of chain or wear of sprocket	Replace chains that are elongated beyond the tolerance and worn sprockets with new ones.
	Incorrect installation of chain case	If the chain contacts the chain case, immediately correct and adjust.
	Improper lubrication	Lubricate properly and periodically. (See "Lubrication types" (P.133).
Improper combination of chain and sprockets	When replacing the chain, use the correct chain size and sprocket sizes. Select a chain suitable for sprocket sizes, and sprockets suitable for the chain size. (Especially be alert when replacing HK Series multiplex chain.)	

Trouble	Possible cause	Correction
When a chain rides over a sprocket	Excessive wear elongation of chain	Replace the excessively worn chain with a new one.
	Chain too slack	A chain with too much slack causes the chain to ride over a sprocket, and can damage the tooth heads of a sprocket. Correctly adjust it.
	Worn sprocket or deposition of foreign substances on tooth gap bottom	Replace the worn sprocket with a new one. If foreign substances are deposited on the bottoms of the teeth, immediately remove them.
Wear of plates and sprockets on their lateral sides	Incorrect alignment of sprockets	Misalignment of large and small sprockets result in abnormal wear of the sides of link plates and the sprockets, thereby shortening chain life. Apply a straight edge to the lateral sides of sprockets to check alignment.
Vibration of chain (whipping)	Chain too slack	Adjust to a proper sag. Consider the installation of spring type idler or tensioner.
	Uneven wear elongation	Imperfect and uneven lubrication causes uneven wear and pitch irregularity. Immediately replace the chain, and lubricate the entire chain evenly.
	Stiff link	See the following column.
Stiff link	Load in excess of tolerance	Select a DID chain with a larger allowable tension.
	Misalignment of sprockets	If the alignment between sprockets is incorrect, the force applied from the sides of the sprockets opens the inner plates, which interferes with the outer plates and cause stiff links. Align the large and small sprockets properly.
	Corrosion of chain Improper lubrication	If a chain is left without lubrication for a long time or in a corrosive atmosphere, rust is generated and smooth motion is inhibited. A corroded chain must be replaced. Be sure to lubricate periodically.
	Interference between plates and foreign substances	If a chain comes in contact with foreign substances during feeding, the inner and outer plates may be opened. Immediately remove the foreign substance.
	Ingress of foreign substances into bending sections of chain.	If sand or mud enters bending sections, remove the chain, and wash and lubricate, or replace the chain. Furthermore, install a case, etc. to prevent the ingress of sand and mud.
Fractured chain	Fatigue fracture	If a chain is used for a long time at a load exceeding the maximum allowable tension, fatigue fracture of plates and bending fatigue fracture of pins occur. If the chain life before fatigue fracture is shorter than the expected life, select a chain with a larger maximum allowable tension. For example, if a DID50 Standard Roller Chain is used for 750 cc motor-cycles, it may be fractured in a short time. In this case, rather than the chain being faulty, the selection was incorrect.
	Ductile fracture of plates Fracture of pins by shear or bending	If a load or impact extremely larger than the allowable tension acts on a chain, ductile fracture of plates or fracture of pins by shear or bending occurs. This fracture occurs when the chain size selected is incorrect and allowable tension is too small. Re-select a proper chain.
	When the chain rides over a sprocket	The fracture caused when the chain rides over a sprocket is mainly caused by wear elongation. Select an appropriate chain, and lubricate properly.
	Hydrogen embrittlement	Remember that a chain might be broken suddenly by hydrogen embrittlement if it comes in contact with acids.
	Interference of foreign substances	If foreign substances interfere with or are seized by the chain during feeding, excessive load acts on the chain, and its life will be shortened or it may break suddenly. Make necessary arrangements for an appropriate service circumstances, and be sure to immediately remove any foreign substances.
Rotation of pin (see P.136)	Excessive tension Riding of chain over sprocket Corrosion of chain and improper lubrication	If excessive tension is the cause, select a chain larger in allowable tension. See the column "When the chain rides over a sprocket". See the third frame of "Stiff link".

Note: See "Fracture patterns of respective chain components" on P.136.

## Fracture patterns of respective chain components

To be aware beforehand of how and which part of the chain is damaged under improper use greatly helps to clarify the cause and determine corrective measures in such an event.

### • Fracture of plate.

When a large tension acts to fracture a plate, as shown in (a), the cut ends are oblique and plastic deformation occurs. However, when the load is slightly larger than the maximum allowable tension, fatigue fracture occurs, and any plastic deformation does not occur as shown in (b). A significant feature of fatigue fracture is that a crack occurs in the direction almost perpendicular to the pitch line (center line between both pins).

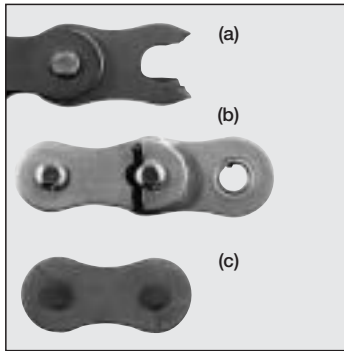

In the case of hydrogen embrittlement by an acid, the crack mostly occurs in the direction as shown in (c), and the cut ends are flat, while the area around the cut ends may be decolorated due to erosion by the acid.

### • Fracture of pins

When a pin is fractured by excessive tension, the fracture occurs close to the plate, with a bulged specular surface formed by shearing, as shown in (d). However, when the acting force is not so strong, fatigue fracture takes place after a long period of time around the center of the pin as shown in (e), and the fractured surface is flat with small undulations.

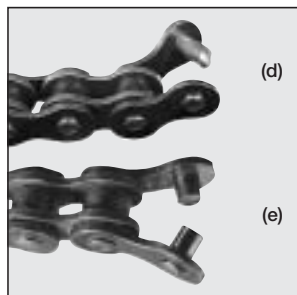

### • Fracture of bushings

As with rollers, bushings fracture by shock. Generally, as shown in the photo, a vertical crack occurs and stops near the plates. One crack can also be superimposed on another, causing the central portion to come off. In general, it can be said that a larger crack is caused by a larger tension.

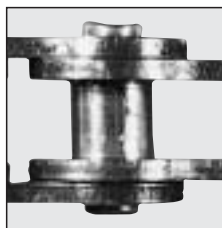

### • Fracture of rollers

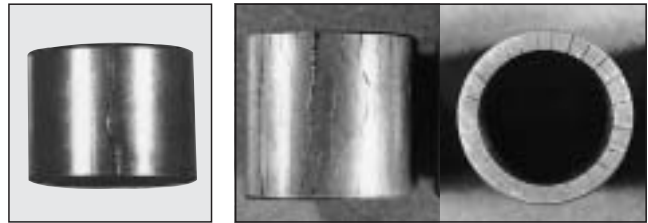

When a roller fractures during operation, typically vertical splitting occurs as shown in the photo, and in general, pitch marks of fatigue extend from the inside of the roller and cause splitting. If splitting occurs all at once due to a large tension, the cause can be identified easily since the split faces are not polished. If tension is excessive, the rollers are forcefully pressed against the tooth faces of sprockets, and a roller end may be cracked and deformed.

### • Rotation of pins

As shown in the photo, the rotation of a pin can be identified by the deviance of the rivet mark on the pin head from the correct position. If the chain is disassembled, galling is found between pins and bushings in most cases. The cause of galling is improper lubrication or excessive tension. When a machine has been out of use for a long period of time, rust may develop between pins and bushings, causing the pin to rotate.



## Elongation of chain

In general, the elongation of chains includes the following three types;

### 1. Elastic elongation by chain tension

If a load acts on a chain, the respective components of the chain are elastically deformed, causing elongation. If the load is removed, the original length is restored.

### 2. Plastic elongation by chain tension

If a load in excess of the elastic limit acts on a chain, plastic elongation occurs. In this case, even if the load is removed, the original length cannot be restored. Plastic elongation of chain may diminish its performance. Replace it without delay.

### 3. Wear elongation of chain

Chains are subject to wear since pins and bushings are worn by mutual contact. After use for a long time, the wear appears as an increase of chain length. This is wear elongation. Wear elongation is an important factor for deciding the timing of chain replacement. See P.137.

## Timing for Replacement

If the engagement between chain and sprockets becomes defective or any factor that causes excessive decline in the strength of the chain occurs, replace the entire chain. When any of the following conditions occur in the chain you use, replace the entire chain to maintain safety.

- When a chain is worn close to the "Elongation limit of chain" on P.130.
  - When a flaw or crack occurs in a plate.
  - When a flaw or crack or defective rotation of a roller is observed.
  - When a chain link is stiff.
  - When a pin has been rotated.
  - When a pin is bent or otherwise deformed or when a plate is seriously warped.
  - When rust buildup prevents smooth bending of the chain.
  - When diluted sulfuric acid or any other corrosive material is deposited.
- ※ If you cannot judge whether a flaw is "harmful", please consult us.

## Replacement of sprockets and how to order

The life of sprockets is generally several times the life of a chain, but if the teeth are worn because of insufficient lubrication or damaged because of a shock load, etc., the sprockets must be replaced.

- When placing an order, please specify the following if the chain No. is known.

1. Chain No. and number of strands
2. Type of sprockets
3. Shaft hole diameter (d) (This is not necessary if you drill this hole; in this case, drill a hole not exceeding the maximum shaft hole diameter.)
4. Number of teeth
5. Hub diameter (DH) and length (L) (in the case of non-standard sprockets)
6. Whether the tooth heads are hardened

- Specify the following items, if the chain No. is unknown

1. Tooth thickness (T)
2. Root diameter (DB) (Caliper diameter (DC) in the case of odd-number teeth)

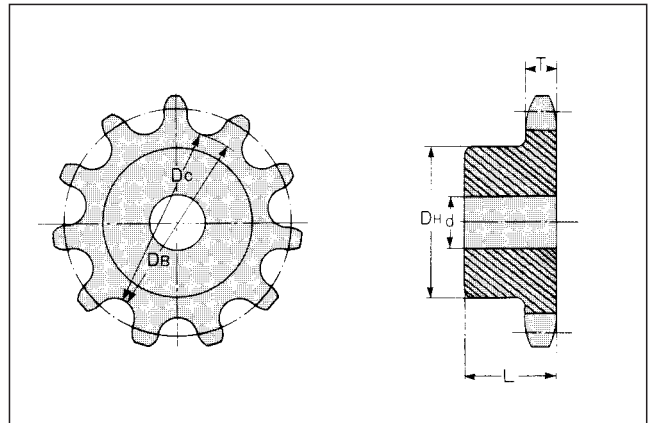





# 2

# Small Conveyor Chains

- General
- Single Pitch
- Double Pitch
- Others
- Technical Information



## Variation of Chain Bodies

The main components of DID Small Conveyor Chain consists of two basic types single pitch chains and double pitch chains.

Single pitch chains correspond to "General application chains" in the previous chapter of "Roller Chains for Power Transmission", and are used with ANSI standard sprockets". Double pitch chains are standardized as ANSI Double Pitch Chains, and the design of pins, bushings and rollers are basically the same as that of single pitch chains. The plates only are made longer to double the pitch of single pitch chains. The sprockets of double pitch roller are also standardized as ANSI double pitch chain sprockets. Small Conveyor Chain is mainly composed of the above base chains, and is attached with various top rollers, side rollers or attachments that customize chains for different applications. Classifications of DID Small Chains for Conveyor Systems are shown on P141.

## Ultimate Life Chain Series and Environment Resistant Chain Series

Ultimate Life Chain Series and Environment Resistant Chain Series described in the previous chapter are also available for Small Conveyor Chains, which are listed on P142-143 for reference.

## How to Order Small Conveyor Chains

- To order DID C2050 with 96 links, with bent attachments (one-hole) on both sides every two links, with a connecting link attached (in straight shape).

[Example]

**DID C2050 2P K 1 × 96 R T**

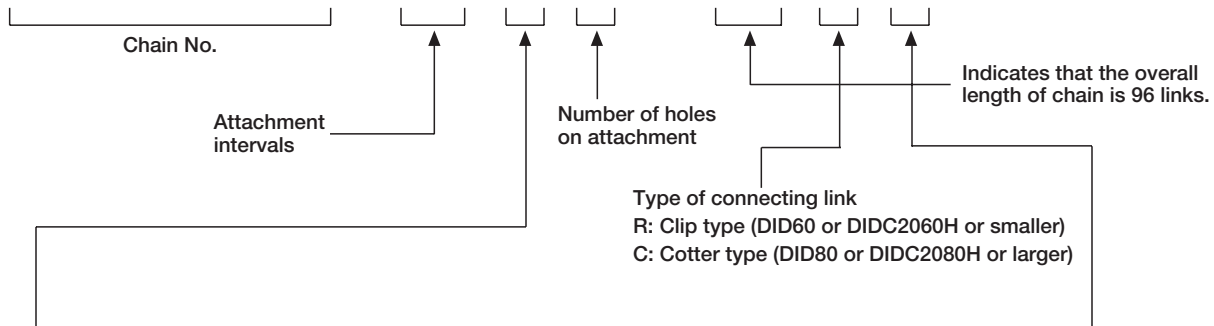

Types of attachments

- K: Bent attachments are installed on both sides
- A: Bent attachments are installed on one side
- SK: Straight attachments are installed on both sides
- SA: Straight attachments are installed on one side

Conditions of connecting link

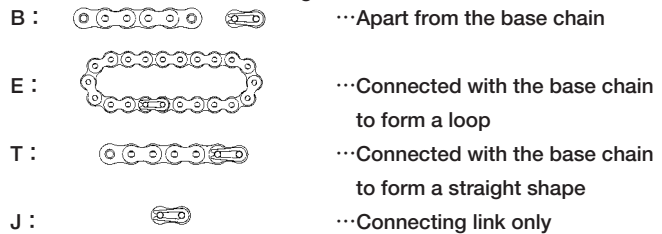



























































※For connections other than those above, see P.145. For any other style, please consult us.  
 ※In case of top roller chains or side roller chains, see the corresponding pages.

## Classification

Major division		Medium division	Minor division	Page
Standard Conveyor Chain with Attachments		Single pitch	Standard	P144~P167
			Ultimate Life	
			Environment Resistance	
		Double pitch	Standard	P174~P195
			Ultimate Life	
			Environment Resistance	
Free Flow Chain	Top Roller Chain	Single pitch	Standard	P198~P203,P206
			Ultimate Life	
			Environment Resistance	
	Double pitch	Standard		
		Ultimate Life		
		Environment Resistance		
Side Roller Chain	Single pitch	Standard	P204~P205,P207	
		Ultimate Life		
		Environment Resistance		
	Double pitch	Standard		
		Ultimate Life		
		Environment Resistance		
Others	Hollow Pin Chain	Single pitch	Standard	P208
			Ultimate Life	
			Environment Resistance	
		Double pitch	Standard	
			Ultimate Life	
			Environment Resistance	
	Flexible Chain	Single pitch	Standard	P209
			Ultimate Life	
			Environment Resistance	
	Frat Plate type Roller Chain	Double pitch	Standard	P210
			Ultimate Life	
			Environment Resistance	

**Standard Conveyor Chain with Attachments Series (Single Pitch)**

Name	Ultimate Life Chain Series					
	Standard Roller Chain	Solid Bushing (HT/ T), (D)	DH- $\alpha$ (DHA)	O-Ring (LD) X-Ring (LX)	Sintered Bushing (UR), (URN)	Nickel Plate (N)
						
Features	<ul style="list-style-type: none"> <li>① Using high precision solid bushings</li> <li>② Higher wear resistance than standard chains</li> <li>③ Wear life is improved by 1.2 to 4 times of standard chains</li> </ul>	<ul style="list-style-type: none"> <li>① Ultra hardening coated pin surface</li> <li>② Suitable for circumstances where foreign substance contamination or extreme oil degradation occurs</li> <li>③ Wear life is improved by 1.2 to 7 times of standard chains</li> </ul>	<ul style="list-style-type: none"> <li>① Grease is filled between pins and bushings.</li> <li>② High-end product of Ultimate Life Chain that can be used anywhere</li> <li>③ Wear life is improved by 5 to 20 times of standard chains</li> </ul>	<ul style="list-style-type: none"> <li>① Using sintered alloy for bushings</li> <li>② Long life chain for low-speed and light load operation</li> <li>③ Wear life is improved by 5 times of standard chains</li> </ul>	<ul style="list-style-type: none"> <li>① Specialized nickel coating</li> <li>② Suitable for circumstances requiring a clean impression and neat appearance</li> <li>③ Withstands salt breeze and acidic conditions</li> </ul>	
Functions	 	  	   	     <p>※ LX: Temp. -10°C~120°C, LD: Temp. -10°C~80°C</p>	  	    
Main uses	   	     	        	     	     	

**Standard Conveyor Chain with attachments (Single pitch): Chain No. and Codes**

Chain No.	Standard	Solid Bushing	DHA	O-Ring/X-Ring	Sintered Bushing	Nickel Plating	Hi-Guard
<b>DID 25</b>	○	<b>HT</b>	<b>DHA</b>	-	-	<b>N</b>	-
<b>DID 35</b>	○	<b>T</b>	<b>DHA</b>	<b>LD</b>	-	<b>N</b>	<b>E</b>
<b>DID 41</b>	○	-	<b>DHA</b>	-	-	<b>N</b>	-
<b>DID 40</b>	○	<b>D</b>	<b>DHA</b>	<b>LX</b>	<b>C**UR,URN</b>	<b>N</b>	<b>E</b>
<b>DID 50</b>	○	<b>D</b>	<b>DHA</b>	<b>LX</b>	<b>C**UR,URN</b>	<b>N</b>	<b>E</b>
<b>DID 60</b>	○	<b>D</b>	<b>DHA</b>	<b>LX</b>	<b>C**UR,URN</b>	<b>N</b>	<b>E</b>
<b>DID 80</b>	○	<b>D</b>	-	<b>LD</b>	<b>C**UR,URN</b>	<b>N</b>	<b>E</b>
<b>DID 100</b>	○	<b>D</b>	-	<b>LD</b>	-	<b>N</b>	<b>E</b>
<b>DID 120</b>	○	-	-	<b>LD</b>	-	<b>N</b>	<b>E</b>
<b>DID 140</b>	○	-	-	<b>LD</b>	-	<b>N</b>	-
<b>DID 160</b>	○	-	-	<b>LD</b>	-	<b>N</b>	-
<b>DID 180</b>	○	-	-	<b>LD</b>	-	-	-
<b>DID 200</b>	○	-	-	<b>LD</b>	-	-	-

Note: 1. Standard chains are available for those indicated with ○.  
 2. Although the ones marked with - aren't standard products, consult us.

Environment Resistance Chain Series

	Hi-Guard (E)	Double Guard (WG)	Stainless Steel Chain		Stainless Steel X-Ring Chain (SSLT)	Low Temperature Resistant Chain (TK)	Name
			(SS)	(SSK)			
	<ul style="list-style-type: none"> <li>① High corrosion resistance coating</li> <li>② Suitable for circumstances both indoors and outdoors where long-term resistance to rusting is required</li> <li>③ Excellent resistance to corrosion, salt and rusting</li> </ul>	<ul style="list-style-type: none"> <li>① Approx. twice more corrosion resistant compared to High Guard Chain</li> <li>② Applicable in mildly acidic or mildly alkaline conditions</li> <li>③ Downsizing is possible compared to Stainless Steel Chain</li> </ul>	<ul style="list-style-type: none"> <li>① 18-8 stainless steel</li> <li>② Suitable for circumstances exposed to chemical agents, water or high temperature</li> <li>③ Best corrosion resistance and heat resistance</li> </ul>	<ul style="list-style-type: none"> <li>① 18-8 stainless steel (plate) + precipitation hardened steel (pin/ bush/ roller)</li> <li>② Suitable for places exposed to chemical agents, water and high temperature</li> <li>③ 1.5 times more allowable tension compared to SS type</li> </ul>	<ul style="list-style-type: none"> <li>① Superb wear resistance</li> <li>② Outstanding cost performance</li> <li>③ Significant reduction in friction-loss</li> </ul>	<ul style="list-style-type: none"> <li>① Using material suitable for low temperature and specialized grease</li> <li>② Suitable for circumstances where temperatures drop down to -40 °C.</li> <li>③ Excellent low temperature strength</li> </ul>	Features
							Functions
							Main uses

Small Conveyor Chains

Single Pitch

	Double Guard	Stainless Steel		Stainless Steel X-Ring Chain	Low Temperature
	-	SS	-	-	-
	-	SS	-	-	-
	-	-	-	-	-
	WG	SS	SSK	SSLT	TK
	WG	SS	SSK	SSLT	TK
	WG	SS	SSK	SSLT	TK
	WG	SS	SSK	SSLT	TK
	-	SS	SSK	-	TK
	-	SS	SSK	-	TK
	-	SS	-	-	TK
	-	SS	-	-	TK
	-	SS	-	-	TK
	-	SS	-	-	-
	-	SS	-	-	-

## Standard Attachments

For "DID Small Conveyor Chains", various links are available for coupling and attaching custom devices directly to the chains. These links are called attachments. The following standard attachments are available.

### Types and names of standard attachments

DID standard attachments include five kinds for single pitch chains and five kinds for double pitch chains as illustrated below. Furthermore, for single pitch chains, four kinds of wide attachments, as wide as outer plates, are available. Standard attachments for respective chain sizes are listed on the following page.

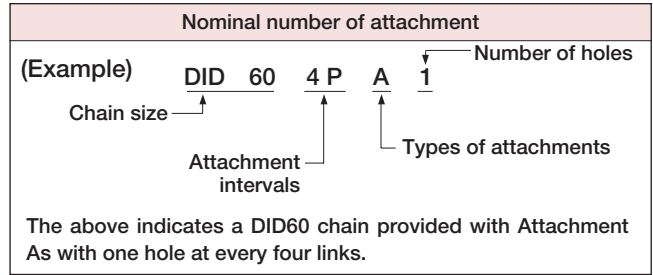

Attachment **A** (Bent attachment on one side)

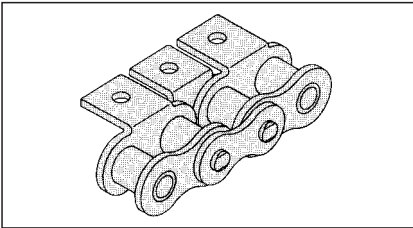

Attachment **SA** (Straight attachment on one side)

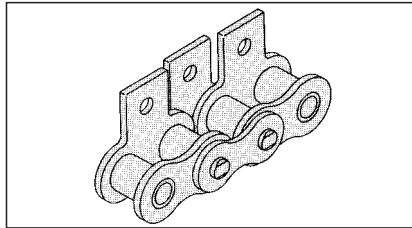

Attachment **D** (Extended pin)

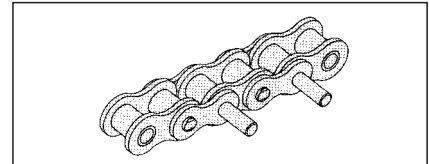

Above figure shows D1 (with an extended pin on every two links)

Attachment **K** (Bent attachments on both sides)

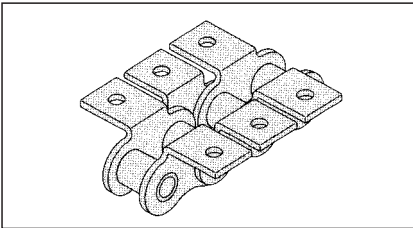

Attachment **SK** (Straight attachments on both sides)

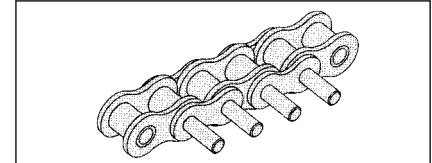
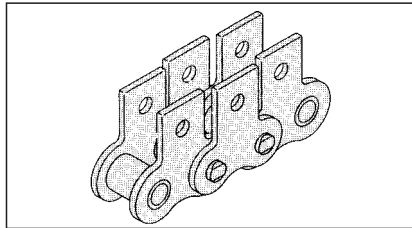

Above figure shows D3 (with an extended pin on every link)

Ref : D pin in longer length is called "LP attachment" (abbreviation of Long Pin)

### Example of use of standard attachment

<p>Installation of a U groove holder with Attachment <b>SK1</b></p>	<p>Installation of a dog with Attachment <b>SK1</b></p>	<p>Installation of pins with Attachment <b>K1</b></p>	<p>Installation of a bucket with Attachment <b>K1</b></p>	<p>Installation of a bucket with Attachment <b>K1</b></p>
<p>Installation of a slat with Attachment <b>A1</b></p>	<p>Conveyance of long article by two stands of Attachment <b>SA1</b></p>	<p>Installation of L metal fitting with <b>D3</b> attachment</p>	<p>Installation of a dog with <b>D1</b> attachment</p>	



# Standard Attachment Chart

○ : In stock  
 △ : Made-to-order  
 × : Special

		DID standard attachment																	
		Standard type										Wide type							
		One-side bent		Both-side bent		One-side straight		Both-side straight		Extended pin		One-side bent		Both side bent		One-side straight		Both-side straight	
		A1	A2	K1	K2	SA1	SA2	SK1	SK2	D1	D3	WA1	WA2	WK1	WK2	WSA1	WSA2	WSK1	WSK2
Single pitch	DID 25	△	×	△	×	△	×	△	×	△	△								
	DID 35	△	×	△	×	△	×	△	×	△	△								
	DID 41	△	×	△	×	△	×	△	×	×	×								
	DID 40	○	×	○	×	△	×	△	×	△	△	△	△	△	△	△	△	△	
	DID 50	○	×	○	×	△	×	△	×	△	△	△	△	△	△	△	△	△	
	DID 60	○	×	○	×	△	×	△	×	△	△	△	△	△	△	△	△	△	
	DID 80	○	×	○	×	△	×	△	×	△	△	△	△	△	△	△	△	△	
	DID 100	○	×	○	×	△	×	△	×	△	△	△	△	△	△	△	△	△	
	DID 120	○	×	○	×	△	×	△	×	△	△	×	×	×	×	×	×	×	
	DID 140	△	×	△	×	△	×	△	×	△	△								
	DID 160	△	×	△	×	△	×	△	×	△	△								
DID 200	△	×	△	×	△	×	△	×	△	△									
DID 240	△	×	△	×	△	×	△	×	×	×									

Roller Chains for Power Transmission

Single Pitch

## How to indicate the specially arranged chains with attachments

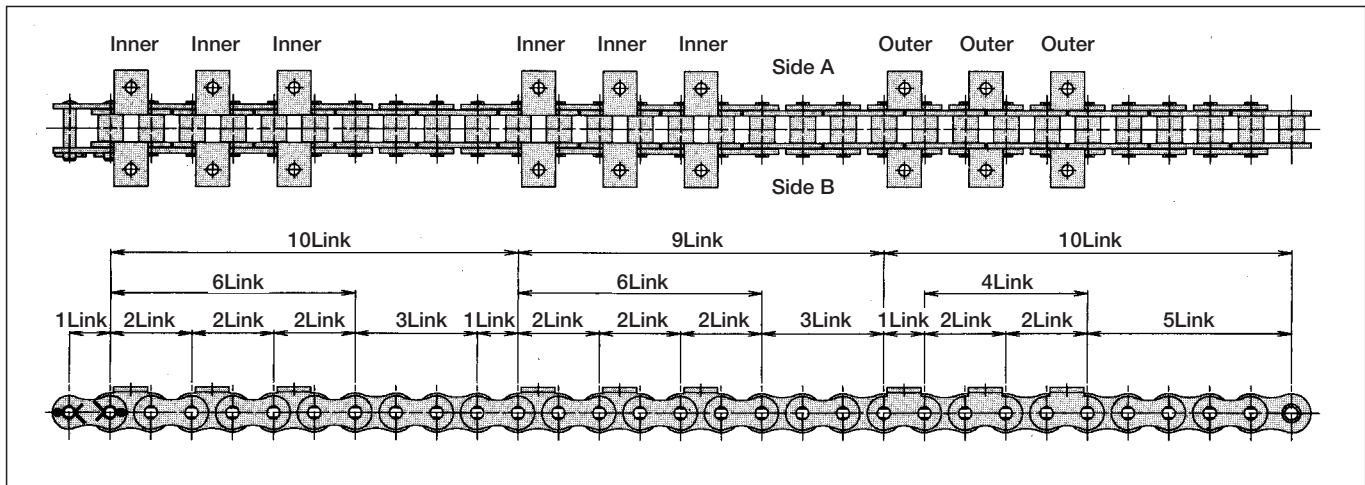

A chain with Attachment K1s specially arranged as above is indicated as follows:

$$CJ + (K1 \text{ inner} + PL) \times 3 + 3LL + PL + (K1 \text{ inner} + PL) \times 3 + 3LL + K1 \text{ outer} + (RL + K1 \text{ outer}) \times 2 + 5LL$$

"CJ" stands for a C connecting link; "K1 inner", an inner link Attachment K1; "PL", an outer link; "3LL", three links from an inner link to an inner link; "K1 outer", an outer link Attachment K1; and "RL", an inner link, respectively. A "+" sign means "connection", and a "×" sign means "repeat". (For one-side attachments such as Attachment A and Attachment SA, the position of attachment plates is on side A in the above illustration.)

Consult us for other arrangements that cannot be indicated as above.  
 Note: When attaching attachments to every even-number link, they are attached to outer links, unless specified.

## Chain Body

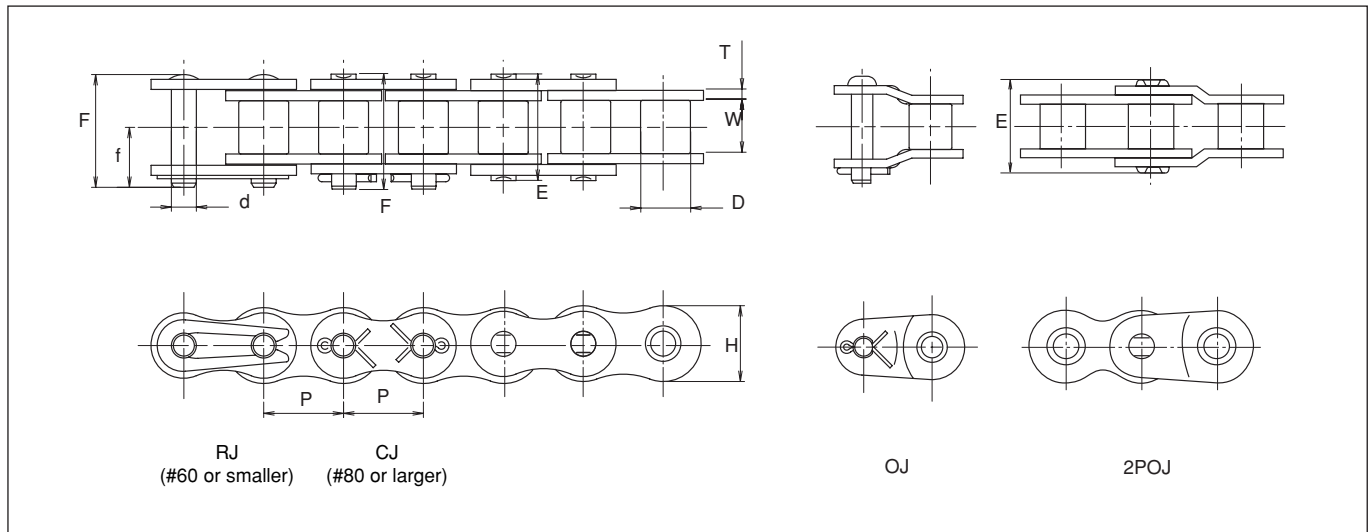

## Attachment

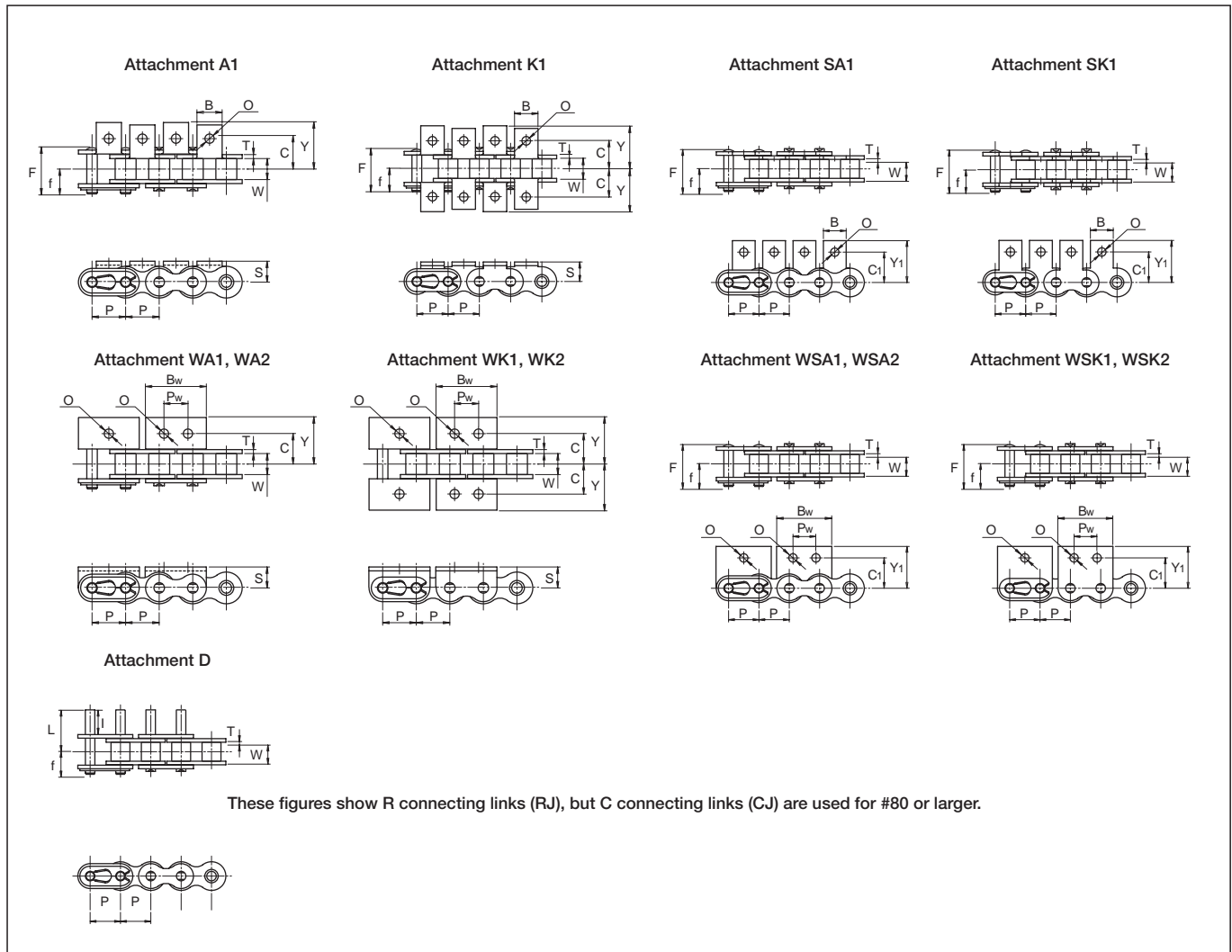

Small Conveyor Chains

Single Pitch

## Dimensions of Standard Roller Chain (Single pitch)

### • Dimensions of Chain Bodies

Unit (mm)

Chain No.	Pitch <b>P</b>	Roller link width <b>W</b>	Roller (pushing) dia. <b>D</b>	Pin				Plate		Avg. tensile strength		Max. allowable load		Approx. weight without attachments (kg/m)
				<b>d</b>	<b>E</b>	<b>F</b>	<b>f</b>	<b>T</b>	<b>H</b>	kN	kgf	kN	kgf	
*DID 25	6.35	3.18	(3.30)	2.31	7.8	8.50	4.7	0.72	5.9	4.02	410	0.63	65	0.13
*DID 35	9.525	4.78	(5.08)	3.59	12.0	13.1	7.3	1.25	9.0	9.31	950	1.47	150	0.32
DID 41	12.70	6.38	7.77	3.59	13.7	14.6	7.9	1.20	9.6	10.1	1,030	1.67	170	0.39
DID 40	12.70	7.95	7.92	3.97	16.5	17.6	9.5	1.50	12.0	16.6	1,700	2.64	270	0.63
DID 50	15.875	9.53	10.16	5.09	20.3	21.9	11.6	2.00	15.0	27.9	2,850	4.41	450	1.06
DID 60	19.05	12.70	11.91	5.96	25.4	26.9	14.3	2.40	18.1	40.2	4,100	6.37	650	1.44
DID 80	25.40	15.88	15.88	7.94	32.6	35.4	19.0	3.20	24.0	78.4	8,000	10.7	1,100	2.55
DID100	31.75	19.05	19.05	9.54	39.5	42.5	22.7	4.00	29.9	118	12,100	17.1	1,750	3.79
DID120	38.10	25.40	22.23	11.11	49.7	53.0	28.2	4.80	35.9	166	17,000	24.5	2,500	5.49
DID140	44.45	25.40	25.40	12.71	53.6	58.4	31.7	5.60	41.9	215	22,000	32.3	3,300	7.11
DID160	50.80	31.75	28.58	14.29	63.6	68.2	36.5	6.40	47.8	269	27,500	41.2	4,200	9.82
DID200	63.50	38.10	39.68	19.85	77.9	85.0	46.0	8.00	60.0	470	48,000	68.6	7,000	16.50

Roller Chains for Power Transmission

Single Pitch

### • Dimensions of attachment

Chain No.	Pitch <b>P</b>	Attachment A1, K1			Attachment SA1, SK1		Common dimensions		Attachment D		Approx. additional weight per attachment (kg)		
		<b>C</b>	<b>Y</b>	<b>S</b>	<b>C<sub>1</sub></b>	<b>Y<sub>1</sub></b>	<b>B</b>	<b>O</b>	<b>I</b>	<b>L</b>	<b>A,SA</b>	<b>K,SK</b>	<b>D</b>
*DID 25	6.35	7.15	10.7	4.76	7.94	11.50	5.56	3.4	6.00	9.2	0.0003	0.0006	0.00002
*DID 35	9.525	9.52	14.4	6.35	9.52	14.70	7.94	3.5	9.52	14.6	0.001	0.002	0.0009
DID 41	12.70	11.91	17.5	7.14	12.30	17.50	9.53	3.5	9.52	15.4	0.0015	0.003	0.0009
DID 40	12.70	12.70	17.6	7.92	12.70	17.50	9.53	3.5	9.52	16.8	0.002	0.004	0.001
DID 50	15.875	15.88	23.0	10.31	15.88	22.60	12.70	5.2	11.91	21.0	0.003	0.006	0.002
DID 60	19.05	19.05	27.0	11.91	18.26	26.20	15.88	5.2	14.27	25.7	0.006	0.012	0.003
DID 80	25.40	25.40	34.9	15.88	24.61	34.05	19.05	6.8	19.05	33.9	0.011	0.022	0.007
DID100	31.75	31.75	43.3	19.84	31.75	42.75	25.40	8.7	23.83	41.9	0.024	0.048	0.012
DID120	38.10	38.10	53.2	23.01	36.53	50.30	28.58	10.3	28.58	51.4	0.037	0.074	0.02
DID140	44.45	44.45	61.9	28.58	44.45	62.40	34.92	12.3	33.32	57.8	0.068	0.136	0.03
DID160	50.80	50.80	69.9	31.75	50.80	68.10	38.10	14.3	38.10	67.4	0.091	0.182	0.045
DID200	63.50	63.50	90.0	42.87	63.50	84.50	47.60	17.0	47.62	83.4	0.186	0.372	0.106

### • Dimensions of wide attachment

Chain No.	Pitch <b>P</b>	Attachment WA1, WA2, WK1, WK2			Attachment WSA1, WSA2, WSK1, WSK2		Common dimensions			Approx. additional weight per attachment (kg)	
		<b>C</b>	<b>Y</b>	<b>S</b>	<b>C<sub>1</sub></b>	<b>Y<sub>1</sub></b>	<b>O</b>	<b>Bw</b>	<b>Pw</b>	<b>WA,WSA</b>	<b>WK,WSK</b>
DID 40	12.70	12.70	17.6	7.92	12.70	17.5	4.5	23.0	9.5	0.003	0.006
DID 50	15.875	15.88	23.0	10.31	15.88	22.6	5.5	28.8	11.9	0.007	0.014
DID 60	19.05	19.05	27.0	11.91	18.26	26.2	6.6	34.6	14.3	0.012	0.024
DID 80	25.40	25.40	34.9	15.88	24.61	34.1	9.0	46.1	19.1	0.026	0.052
DID100	31.75	31.75	43.3	19.84	31.75	42.8	11.0	57.8	23.8	0.051	0.102

Note: 1. Those marked with \* indicate Bushing Chain.

2. The values of the Avg. tensile strength and Max. allowable load are for the chain body (attachments aren't included).

## Chain Body

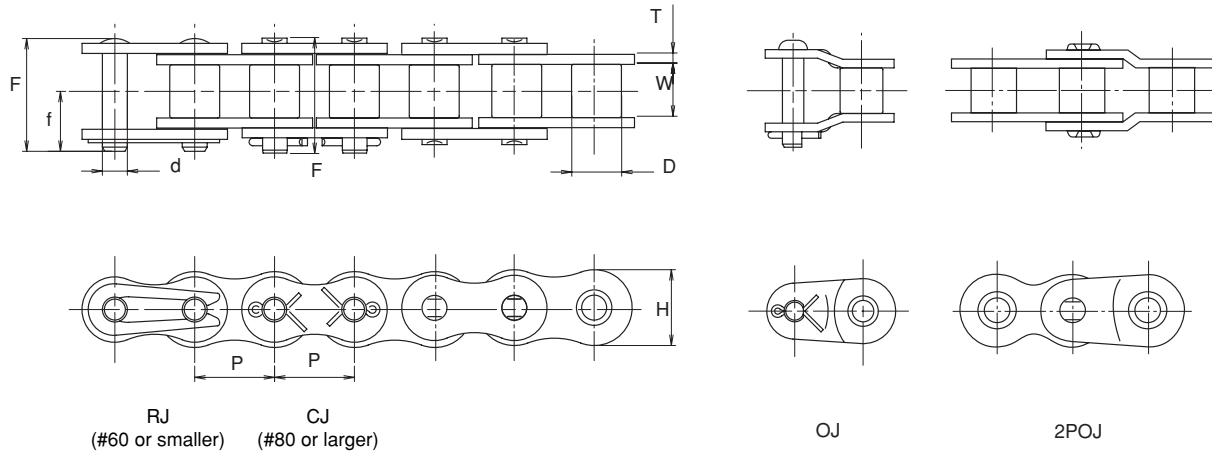

## Attachment

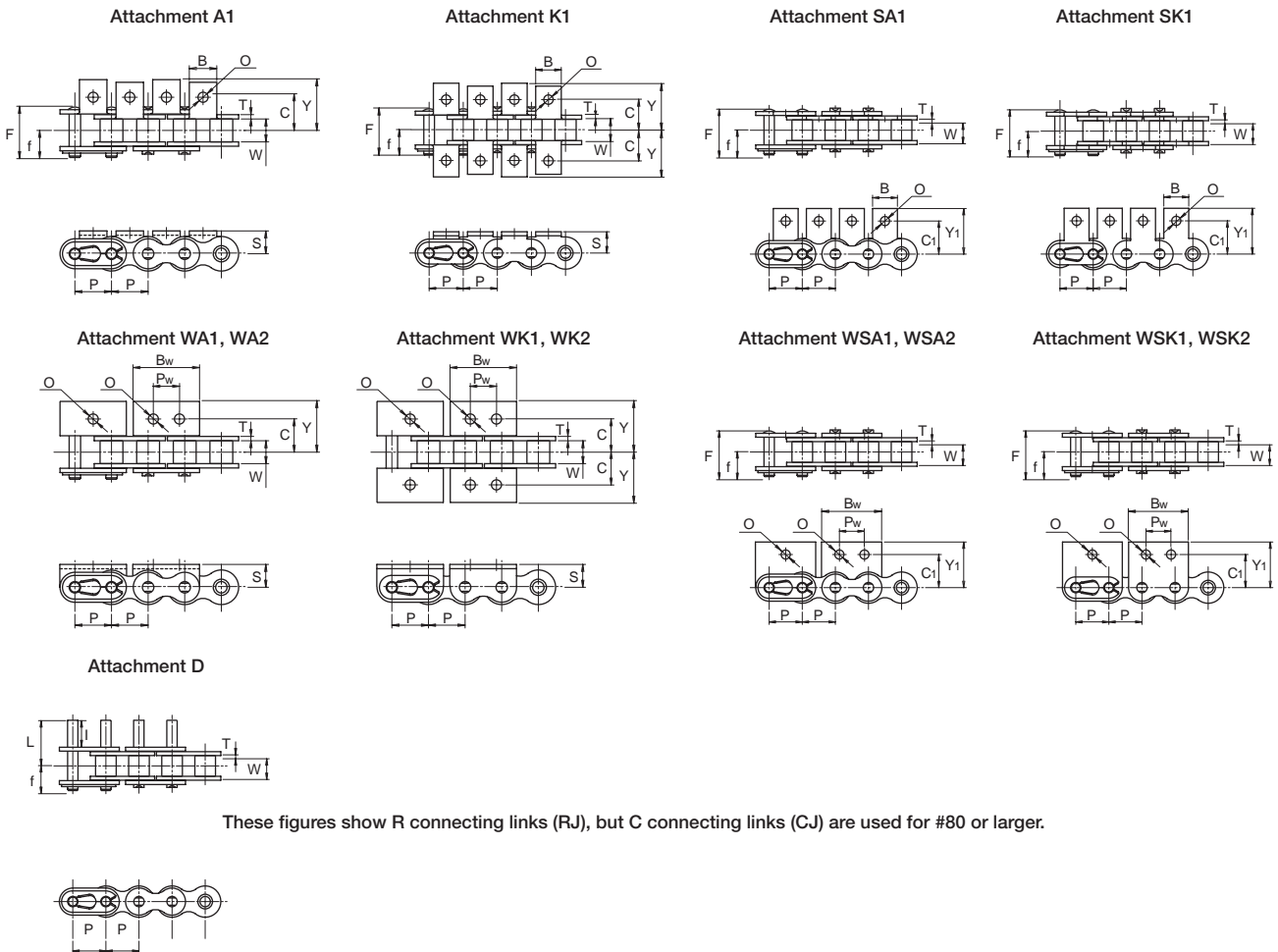



## Dimensions of Long Life Chains (Single pitch)

### • Dimensions of Chain Bodies

Unit (mm)

Chain No.	Pitch <b>P</b>	Roller link width <b>W</b>	Roller (bush) dia. <b>D</b>	Pin			Plate		Avg. tensile strength		Max. allowable load		Approx. weight without attachments (kg/m)
				<b>d</b>	<b>F</b>	<b>f</b>	<b>T</b>	<b>H</b>	kN	kgf	kN	kgf	
* <b>DID35T</b>	9.525	4.78	(5.08)	3.59	13.1	7.3	1.25	9.0	9.31	950	1.47	150	0.32
<b>DID40D</b>	12.70	7.95	7.92	3.97	17.6	9.5	1.5	12.0	16.6	1,700	2.64	270	0.63
<b>DID50D</b>	15.875	9.53	10.16	5.09	21.9	11.6	2.0	15.0	27.9	2,850	4.41	450	1.06
<b>DID60D</b>	19.05	12.7	11.91	5.96	26.9	14.3	2.4	18.1	40.2	4,100	6.37	650	1.44
<b>DID80D</b>	25.40	15.88	14.88	7.94	35.4	19.0	3.2	24.0	78.4	8,000	10.7	1,100	2.67
<b>DID100D</b>	31.75	19.05	19.05	9.54	42.5	22.7	4.0	29.9	118	12,100	17.1	1,750	3.99

### • Dimensions of attachment

Chain No.	Attachment A1, K1			Attachment SA1, SK1		Common dimensions		Attachment D		Approx. additional weight per attachment (kg)		
	<b>C</b>	<b>Y</b>	<b>S</b>	<b>C<sub>1</sub></b>	<b>Y<sub>1</sub></b>	<b>B</b>	<b>O</b>	<b>I</b>	<b>L</b>	<b>A,SA</b>	<b>K,SK</b>	<b>D</b>
* <b>DID 35T</b>	9.52	14.4	6.35	9.52	14.70	7.94	3.5	9.52	14.6	0.001	0.002	0.0009
<b>DID 40D</b>	12.70	17.6	7.92	12.70	17.50	9.53	3.5	9.52	16.8	0.002	0.004	0.001
<b>DID 50D</b>	15.88	23.0	10.31	15.88	22.60	12.70	5.2	11.91	21.0	0.003	0.006	0.002
<b>DID 60D</b>	19.05	27.0	11.91	18.26	26.20	15.88	5.2	14.27	25.7	0.006	0.012	0.003
<b>DID 80D</b>	25.40	34.9	15.88	24.61	34.05	19.05	6.8	19.05	33.9	0.011	0.022	0.007
<b>DID100D</b>	31.75	43.3	19.84	31.75	42.75	25.40	8.7	23.83	41.9	0.024	0.048	0.012

### • Dimensions of wide attachment

Chain No.	Pitch <b>P</b>	Attachment WA1, WA2, WK1, WK2			Attachment WSA1, WSA2, WSK1, WSK2		Common dimensions			Approx. additional weight per attachment (kg)	
		<b>C</b>	<b>Y</b>	<b>S</b>	<b>C<sub>1</sub></b>	<b>Y<sub>1</sub></b>	<b>O</b>	<b>Bw</b>	<b>Pw</b>	<b>WA,WSA</b>	<b>WK,WSK</b>
* <b>DID 35T</b>	9.525	-	-	-	-	-	-	-	-	-	-
<b>DID 40D</b>	12.70	12.70	17.6	7.92	12.70	17.5	4.5	23.0	9.5	0.003	0.006
<b>DID 50D</b>	15.875	15.88	23.0	10.31	15.88	22.6	5.5	28.8	11.9	0.007	0.014
<b>DID 60D</b>	19.05	19.05	27.0	11.91	18.26	26.2	6.6	34.6	14.3	0.012	0.024
<b>DID 80D</b>	25.40	25.40	34.9	15.88	24.61	34.1	9.0	46.1	19.1	0.026	0.052
<b>DID100D</b>	31.75	31.75	43.3	19.84	31.75	42.8	11.0	57.7	23.8	0.051	0.102

Note: 1. Those marked with \* indicate Bushing Chain.

2. The values of the Avg. tensile strength and Max. allowable load are for the chain body (attachments aren't included).

## Chain Body

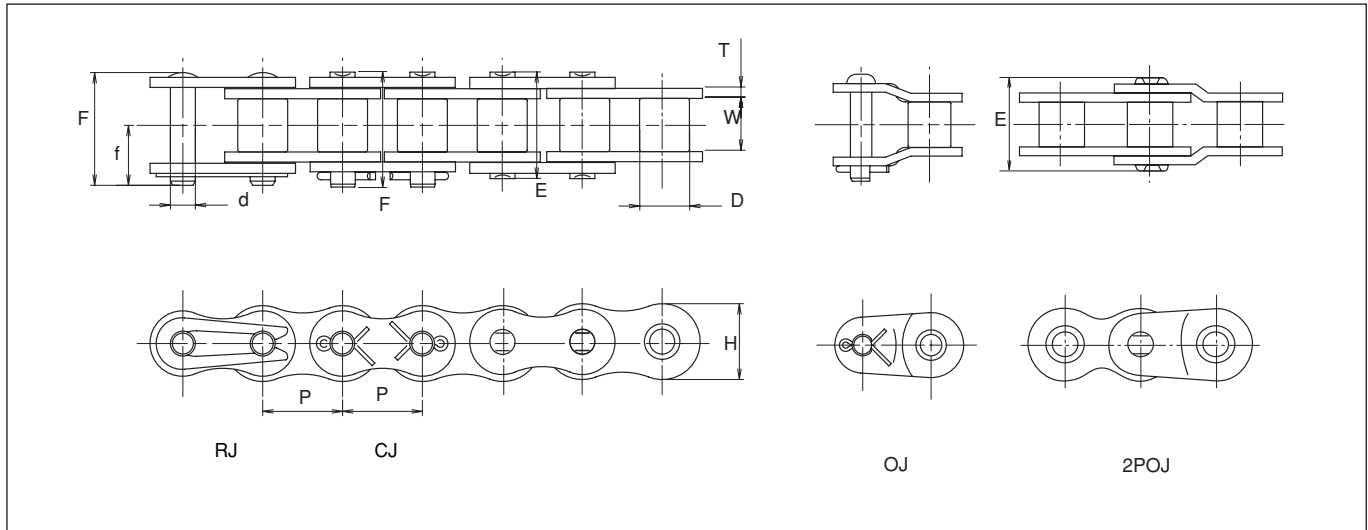

## Attachment

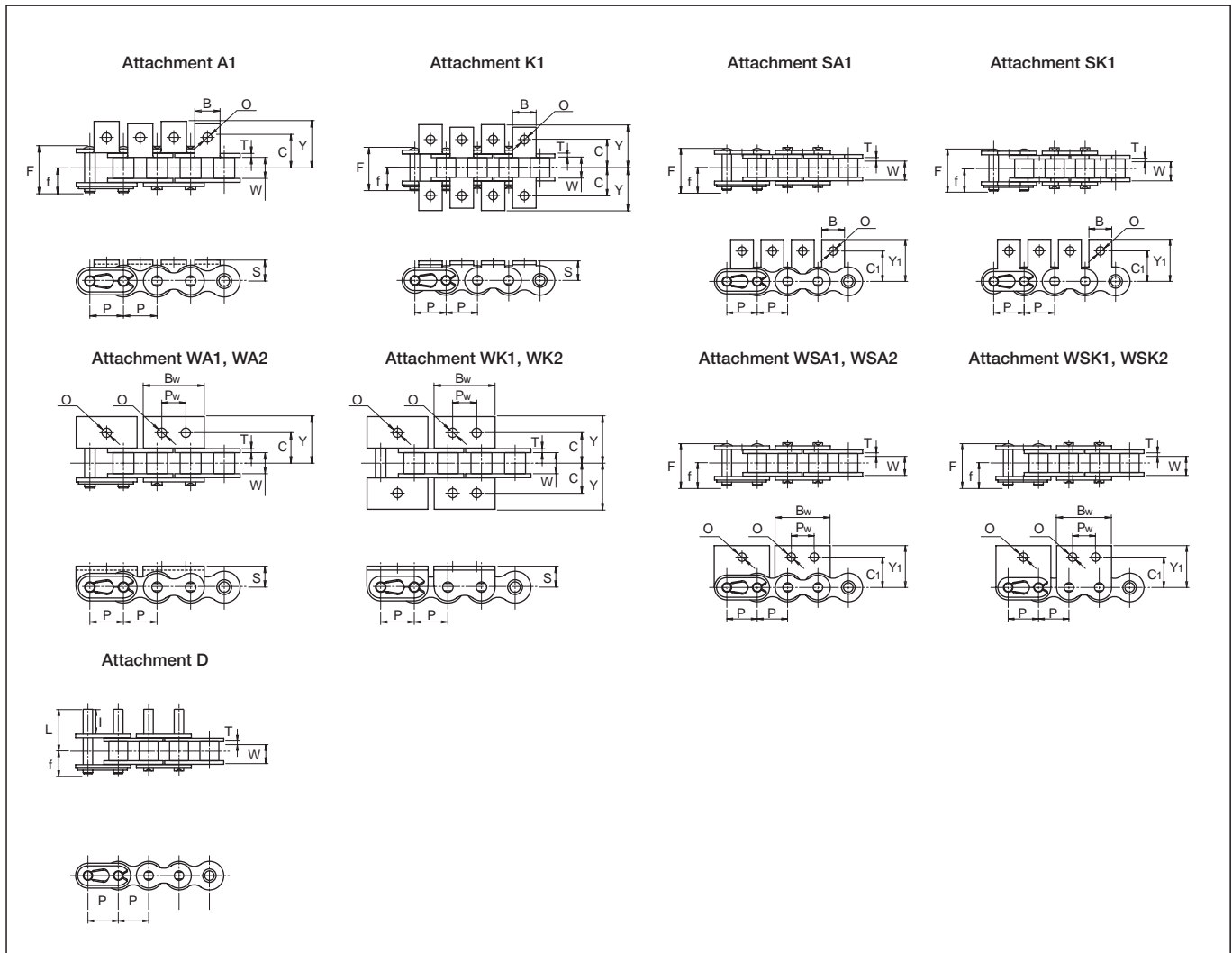





## Dimensions of DH- $\alpha$ Chain (Single pitch)

### • Dimensions of Chain Bodies

Unit (mm)

Chain No.	Pitch <b>P</b>	Roller link width <b>W</b>	Roller (bush) dia. <b>D</b>	Pin				Plate		Avg. tensile strength		Max. allowable load		Approx. weight without attachments (kg/m)
				<b>d</b>	<b>E</b>	<b>F</b>	<b>f</b>	<b>T</b>	<b>H</b>	kN	kgf	kN	kgf	
* <b>DID25DHA</b>	6.35	3.18	(3.30)	2.31	7.8	8.5	4.7	0.72	5.9	4.02	410	0.63	65	0.13
* <b>DID35DHA</b>	9.525	4.78	(5.08)	3.59	12.0	13.1	7.3	1.25	9.0	9.31	950	1.47	150	0.32
<b>DID41DHA</b>	12.70	6.38	7.77	3.59	13.7	14.6	7.9	1.2	9.6	10.1	1,030	1.67	170	0.39
<b>DID40DHA</b>	12.70	7.95	7.92	3.97	16.5	17.6	9.5	1.5	12.0	16.6	1,700	2.64	270	0.63
<b>DID50DHA</b>	15.875	9.53	10.16	5.09	20.3	21.9	11.6	2.0	15.0	27.9	2,850	4.41	450	1.06
<b>DID60DHA</b>	19.05	12.70	11.91	5.96	25.4	26.9	14.3	2.4	18.1	40.2	4,100	6.37	650	1.44

### • Dimensions of attachment

Chain No.	Attachment A1, K1			Attachment SA1, SK1		Common dimensions		Attachment D		Approx. additional weight per attachment (kg)		
	<b>C</b>	<b>Y</b>	<b>S</b>	<b>C<sub>1</sub></b>	<b>Y<sub>1</sub></b>	<b>B</b>	<b>O</b>	<b>I</b>	<b>L</b>	<b>A,SA</b>	<b>K,SK</b>	<b>D</b>
* <b>DID 25DHA</b>	7.15	10.7	4.76	7.94	11.5	5.56	3.4	6.00	9.2	0.0003	0.0006	0.00002
* <b>DID 35DHA</b>	9.52	14.4	6.35	9.52	14.7	7.94	3.5	9.52	14.6	0.001	0.002	0.0009
<b>DID 41DHA</b>	11.91	17.5	7.14	12.30	17.5	9.53	3.5	9.52	15.4	0.0015	0.003	0.0009
<b>DID 40DHA</b>	12.70	17.6	7.92	12.70	17.5	9.53	3.5	9.52	16.8	0.002	0.004	0.001
<b>DID 50DHA</b>	15.88	23.0	10.31	15.88	22.6	12.70	5.2	11.91	21.0	0.003	0.006	0.002
<b>DID 60DHA</b>	19.05	27.0	11.91	18.26	26.2	15.88	5.2	14.27	25.7	0.006	0.012	0.003

### • Dimensions of wide attachment

Chain No.	Pitch <b>P</b>	Attachment WA1, WA2, WK1, WK2			Attachment WSA1, WSA2, WSK1, WSK2		Common dimensions			Approx. additional weight per attachment (kg)	
		<b>C</b>	<b>Y</b>	<b>S</b>	<b>C<sub>1</sub></b>	<b>Y<sub>1</sub></b>	<b>O</b>	<b>Bw</b>	<b>Pw</b>	<b>WA,WSA</b>	<b>WK,WSK</b>
* <b>DID 25DHA</b>	6.35	-	-	-	-	-	-	-	-	-	-
* <b>DID 35DHA</b>	9.525	-	-	-	-	-	-	-	-	-	-
<b>DID 41DHA</b>	12.70	-	-	-	-	-	-	-	-	-	-
<b>DID 40DHA</b>	12.70	12.70	17.6	7.92	12.70	17.5	4.5	23.0	9.5	0.003	0.006
<b>DID 50DHA</b>	15.875	15.88	23.0	10.31	15.88	22.6	5.5	28.8	11.9	0.007	0.014
<b>DID 60DHA</b>	19.05	19.05	27.0	11.91	18.26	26.2	6.6	34.6	14.3	0.012	0.024

Note: 1. Those marked with \* indicate Bushing Chain.

2. The values of the Avg. tensile strength and Max. allowable load are for chain bodies (attachments aren't included).

### Chain Body

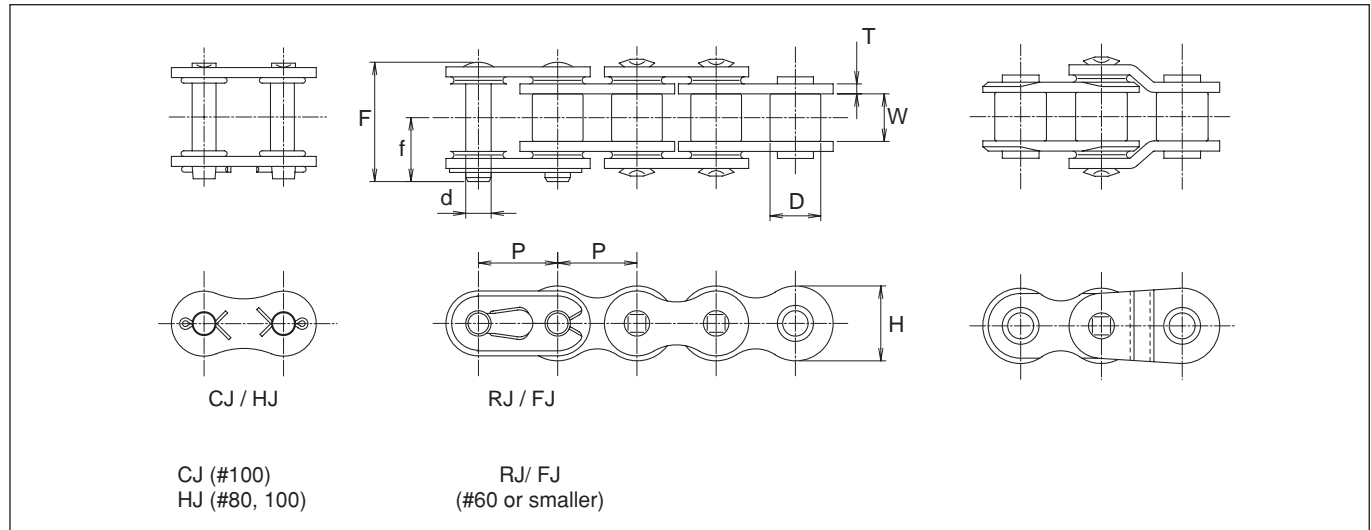

Small Conveyor Chains

Single Pitch

### Attachment

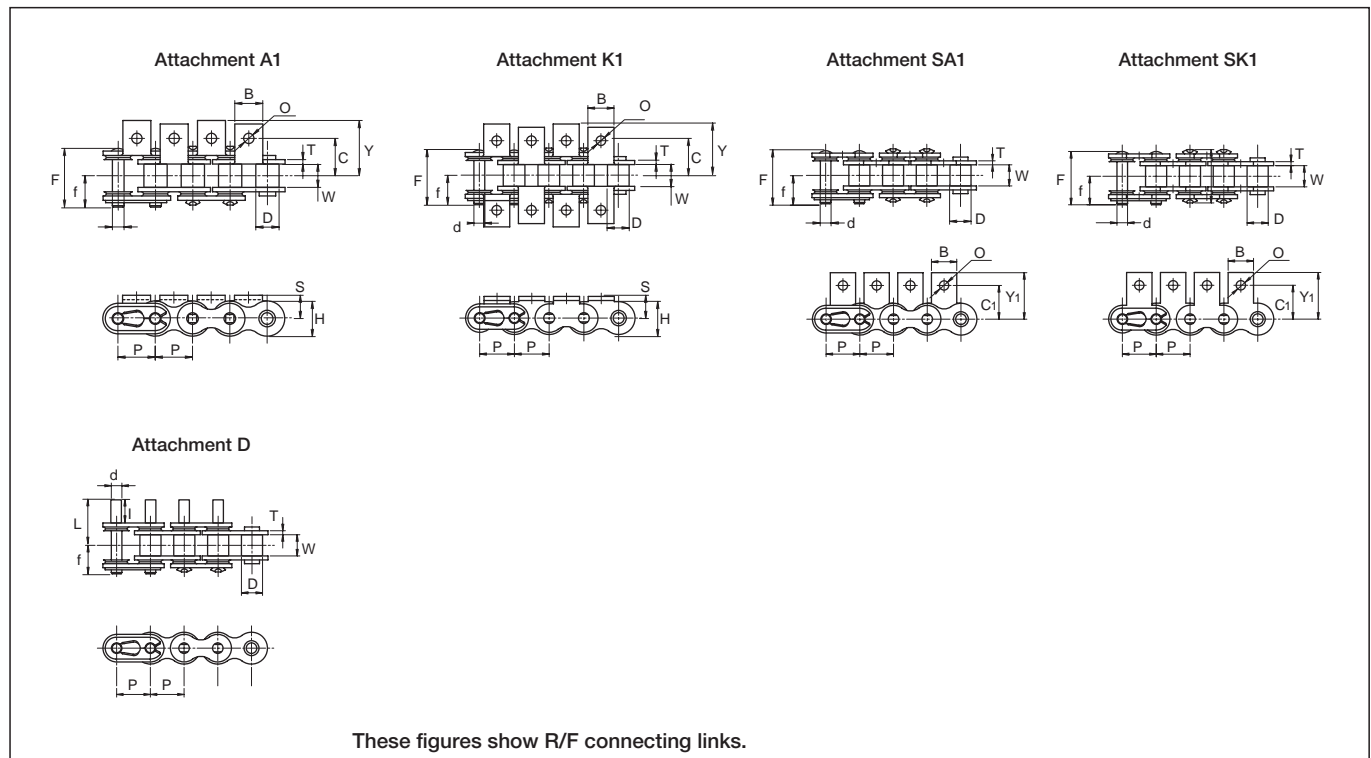



## Dimensions of O-Ring/ X-Ring Chains (Single pitch)

### • Dimensions of Chain Bodies

Unit (mm)

Chain No.		Pitch <b>P</b>	Roller link width <b>W</b>	Roller (bush) dia. <b>D</b>	Pin				Plate		Avg. tensile strength		Max. allowable load		Approx. weight without attachments (kg/m)
Standard	Rustless				<b>d</b>	<b>E</b>	<b>F</b>	<b>f</b>	<b>T</b>	<b>H</b>	kN	kgf	kN	kgf	
<b>DID 40LX</b>	<b>DID 40LXN</b>	12.70	7.95	7.92	3.97	20.0	20.0	10.7	1.5	12.0	18.1	1,850	3.72	380	0.67
<b>DID 50LX</b>	<b>DID 50LXN</b>	15.875	9.53	10.16	5.09	23.4	23.9	12.8	2.0	15.0	30.1	3,070	6.86	700	1.08
<b>DID 60LX</b>	<b>DID 60LXN</b>	19.05	12.70	11.91	5.96	29.2	30.0	16.0	2.4	18.1	42.8	4,370	9.31	950	1.62
<b>DID 80LD</b>	<b>DID 80LDN</b>	25.40	15.88	15.88	7.94	36.5	38.5	20.9	3.2	24.0	72.5	7,400	14.7	1,500	2.83
<b>DID100LD</b>	<b>DID100LDN</b>	31.75	19.05	19.05	9.54	44.0	46.2	24.7	4.0	29.9	107.0	11,000	22.5	2,300	4.07

Note: The values of the Avg. tensile strength and Max. allowable load are for chain bodies (attachments aren't included).

### • Dimensions of attachment

Chain No.		Attachment A1, K1			Attachment SA1, SK1		Common dimensions		Attachment D		Approx. additional weight per attachment (kg)		
Standard	Rustless	<b>C</b>	<b>Y</b>	<b>S</b>	<b>C<sub>1</sub></b>	<b>Y<sub>1</sub></b>	<b>B</b>	<b>O</b>	<b>I</b>	<b>L</b>	<b>A,SA</b>	<b>K,SK</b>	<b>D</b>
<b>DID 40LX</b>	<b>DID 40LXN</b>	12.70	18.8	7.92	12.70	17.50	9.53	3.5	9.5	17.9	0.002	0.004	0.001
<b>DID 50LX</b>	<b>DID 50LXN</b>	15.88	24.1	10.31	15.88	22.60	12.70	5.2	11.9	22.1	0.003	0.006	0.002
<b>DID 60LX</b>	<b>DID 60LXN</b>	19.05	28.4	11.91	18.26	26.20	15.88	5.2	14.3	27.2	0.006	0.012	0.003
<b>DID 80LD</b>	<b>DID 80LDN</b>	25.40	36.6	15.88	24.61	34.05	19.05	6.8	19.1	35.4	0.011	0.022	0.007
<b>DID100LD</b>	<b>DID100LDN</b>	31.75	45.1	19.84	31.75	42.75	25.40	8.7	23.8	43.6	0.024	0.048	0.012

Note: Consult us for the use of Attachment WA, WSA, WK, and WSK for O-Ring Chains.

## Chain Body

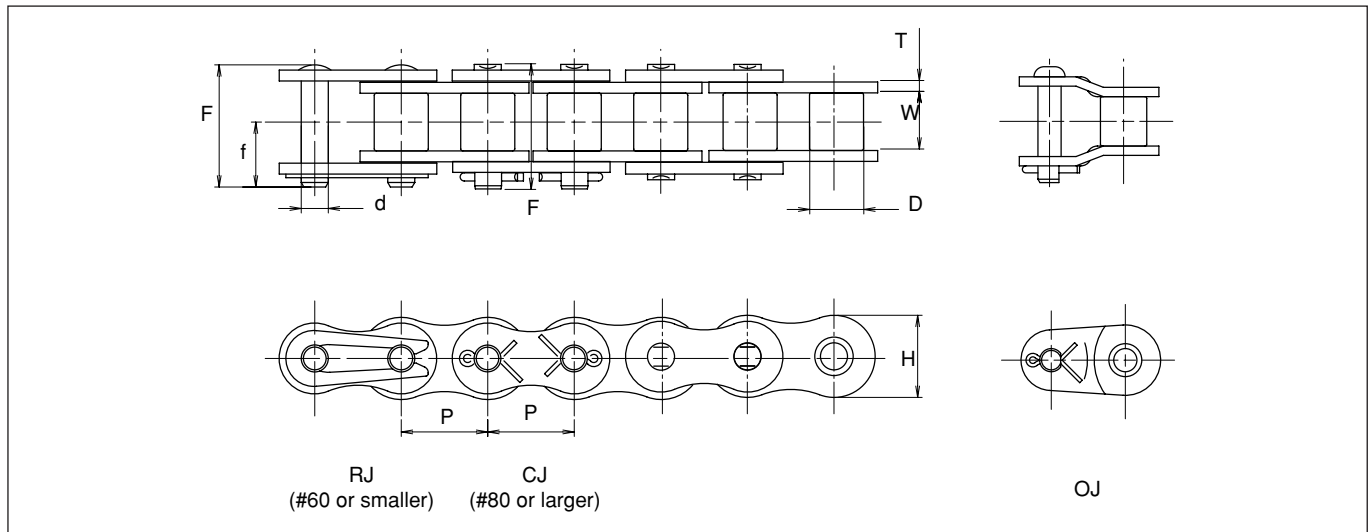

## Attachment

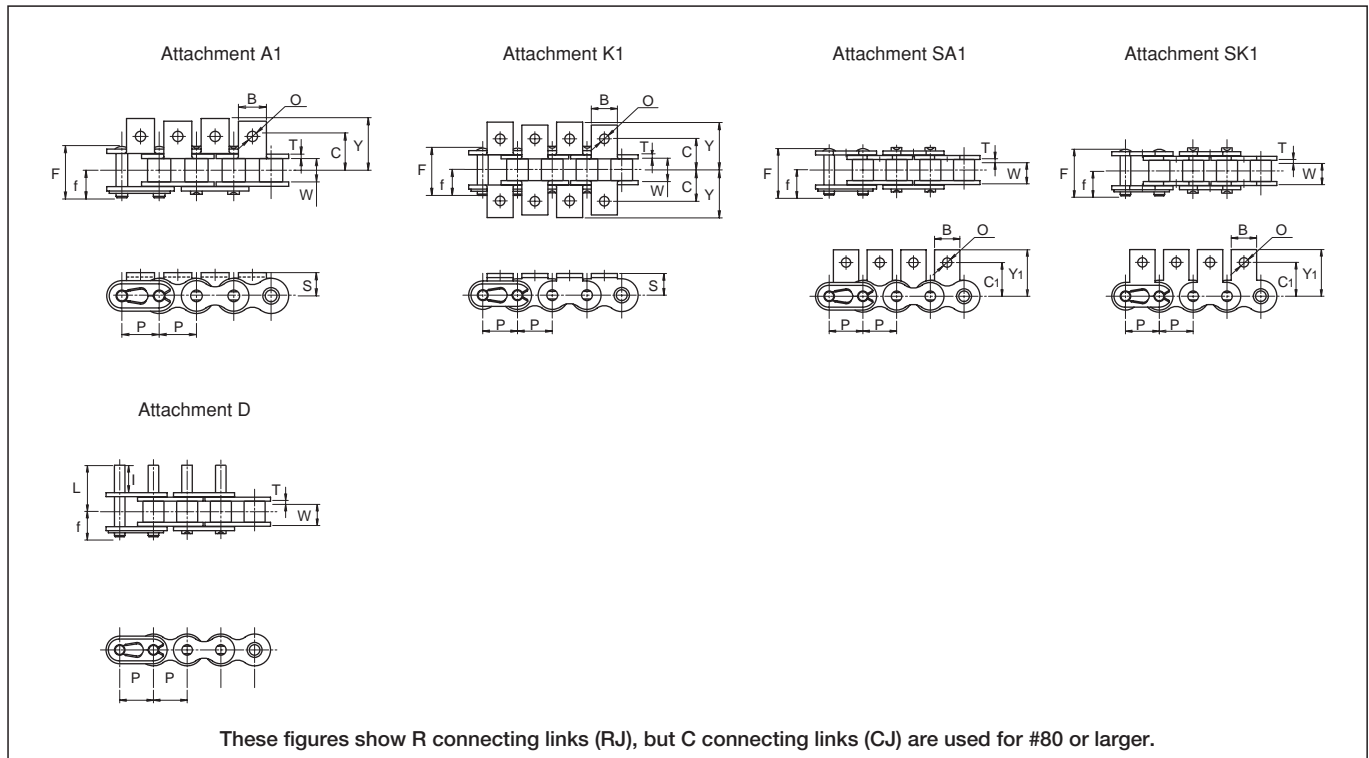

Small Conveyor Chains

Single Pitch



## Dimensions of Sintered Bushing Roller Chain (Single pitch)

### • Dimensions of Chain Bodies

Unit (mm)

Chain No.		Pitch <b>P</b>	Roller link width <b>W</b>	Roller (bush) dia. <b>D</b>	Pin				Plate		Avg. tensile strength		Max. allowable load		Approx. weight without attachments (kg/m)
Standard	Rustless				<b>d</b>	<b>E</b>	<b>F</b>	<b>f</b>	<b>T</b>	<b>H</b>	kN	kgf	kN	kgf	
<b>DID C40 UR</b>	<b>DID C40 URN</b>	12.70	7.95	7.92	3.97	16.5	17.6	9.5	1.5	12.0	15.6	1,600	2.64	270	0.63
<b>DID C50 UR</b>	<b>DID C50 URN</b>	15.875	9.53	10.16	5.09	20.3	21.9	11.6	2.0	15.0	25.4	2,600	4.31	440	1.06
<b>DID C60 UR</b>	<b>DID C60 URN</b>	19.05	12.70	11.91	5.96	25.4	27.1	14.3	2.4	18.1	37.2	3,800	6.27	640	1.44
<b>DID C80 UR</b>	<b>DID C80 URN</b>	25.40	15.88	15.88	7.94	32.5	35.4	19.0	3.2	24.0	63.7	6,500	10.68	1,090	2.67

### • Dimensions of attachment

Chain No.		Pitch <b>P</b>	Attachment A1, K1			Attachment SA, SK		Common dimensions		Attachment D		Approx. additional weight per attachment (kg)		
Standard	Rustless		<b>C</b>	<b>Y</b>	<b>S</b>	<b>C<sub>1</sub></b>	<b>Y<sub>1</sub></b>	<b>B</b>	<b>O</b>	<b>I</b>	<b>L</b>	<b>A,SA</b>	<b>K,SK</b>	<b>D</b>
<b>DID C40 UR</b>	<b>DID C40 URN</b>	12.70	12.70	17.6	7.92	12.70	17.50	9.53	3.5	9.52	16.8	0.002	0.004	0.001
<b>DID C50 UR</b>	<b>DID C50 URN</b>	15.875	15.88	23.0	10.31	15.88	22.60	12.70	5.2	11.91	21.0	0.003	0.006	0.002
<b>DID C60 UR</b>	<b>DID C60 URN</b>	19.05	19.05	27.0	11.91	18.26	26.20	15.88	5.2	14.27	25.7	0.006	0.012	0.003
<b>DID C80 UR</b>	<b>DID C80 URN</b>	25.40	25.40	34.9	15.88	24.61	34.05	19.05	6.8	19.05	33.9	0.011	0.022	0.007

Note: 1. The values of the Avg. tensile strength and Max. allowable load are for chain bodies (attachments aren't included).

2. The alphabet C following DID indicates that the chain is for a conveyor system, and the thickness of the inner plate is the same as the outer plate. (The thickness of the inner plate of the Bushing Roller Chain for Transmission is thicker.)

## Chain Body

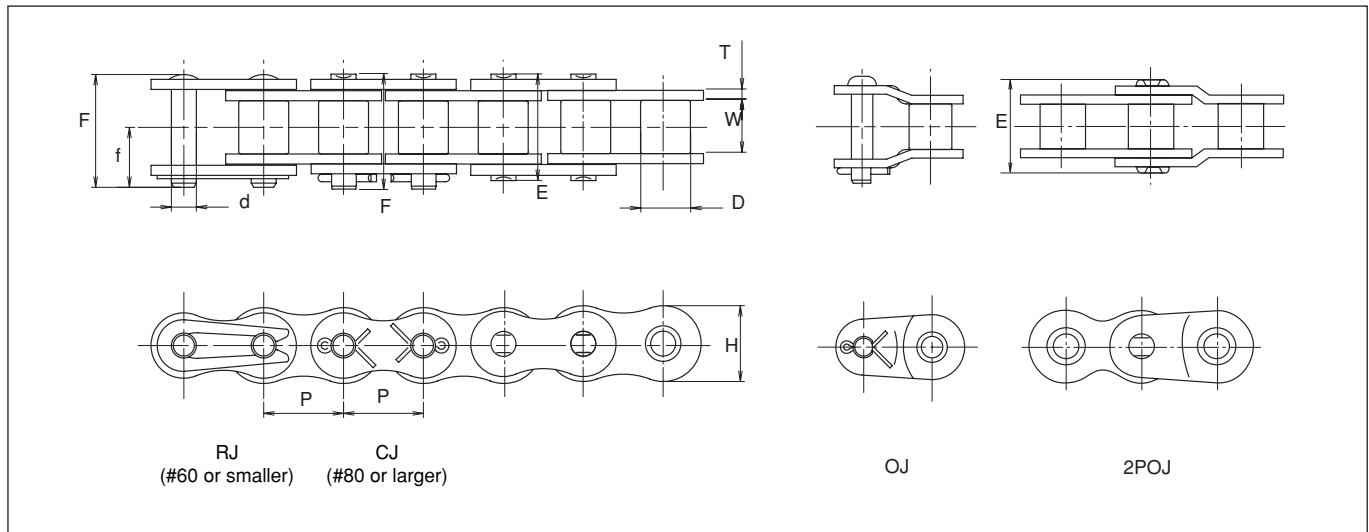

## Attachment

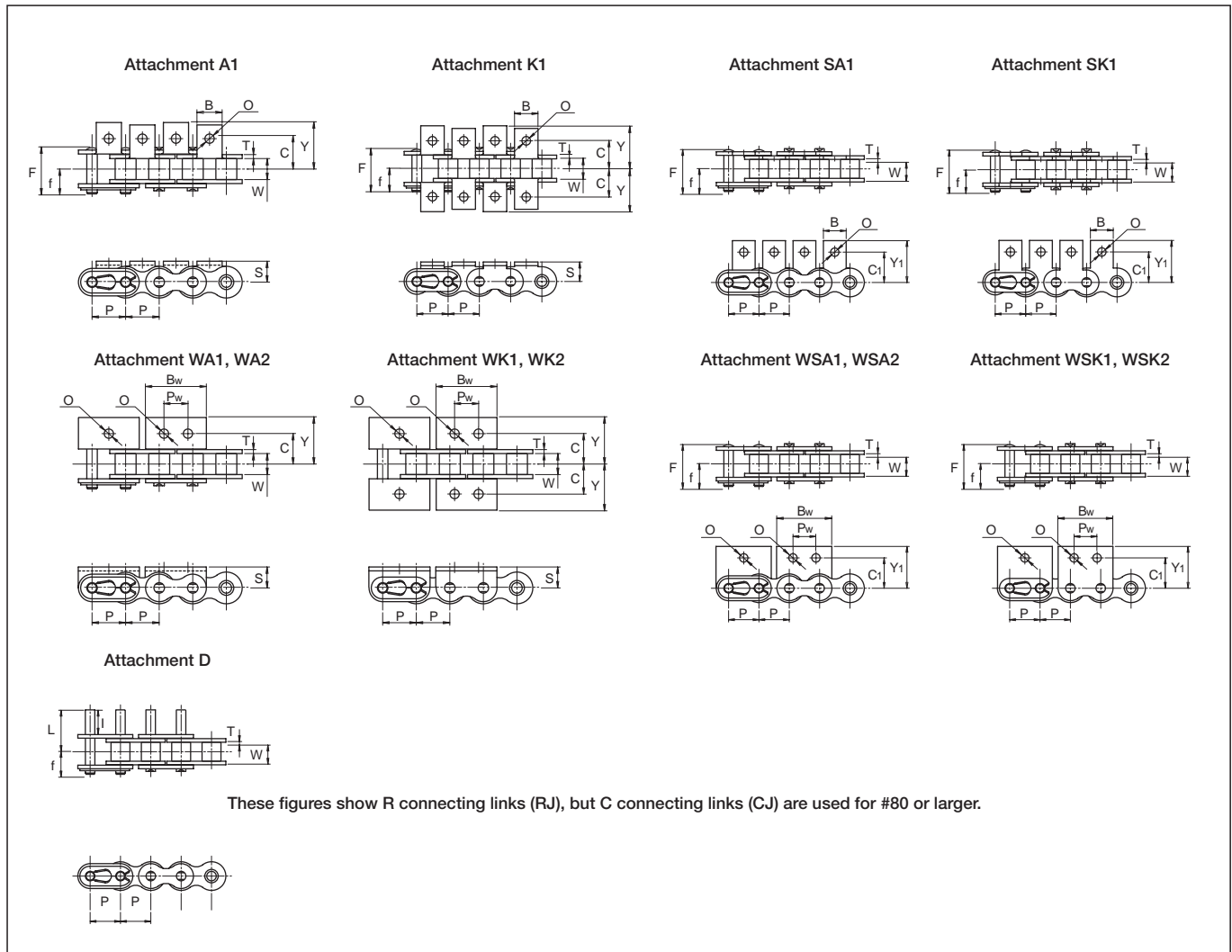

Small Conveyor Chains  
 Single Pitch





## Dimensions of Rustless Chain (Single pitch)

### • Dimensions of Chain Bodies

Unit (mm)

Chain No.	Pitch <b>P</b>	Roller link width <b>W</b>	Roller (bush) dia. <b>D</b>	Pin				Plate		Avg. tensile strength		Max. allowable load		Approx. weight without attachments (kg/m)
				<b>d</b>	<b>E</b>	<b>F</b>	<b>f</b>	<b>T</b>	<b>H</b>	kN	kgf	kN	kgf	
* <b>DID 25N</b>	6.35	3.18	(3.30)	2.31	7.8	8.50	4.7	0.72	5.9	4.02	410	0.63	65	0.13
* <b>DID 35N</b>	9.525	4.78	(5.08)	3.59	12.0	13.1	7.3	1.25	9.0	9.31	950	1.47	150	0.32
<b>DID 41N</b>	12.70	6.38	7.77	3.59	13.7	14.6	7.9	1.20	9.6	10.1	1,030	1.67	170	0.39
<b>DID 40N</b>	12.70	7.95	7.92	3.97	16.5	17.6	9.5	1.50	12.0	16.6	1,700	2.64	270	0.63
<b>DID 50N</b>	15.875	9.53	10.16	5.09	20.3	21.9	11.6	2.00	15.0	27.9	2,850	4.41	450	1.06
<b>DID 60N</b>	19.05	12.7	11.91	5.96	25.4	26.9	14.3	2.40	18.1	40.2	4,100	6.37	650	1.44
<b>DID 80N</b>	25.40	15.88	15.88	7.94	32.6	35.4	19.0	3.20	24.0	78.4	8,000	10.7	1,100	2.55
<b>DID100N</b>	31.75	19.05	19.05	9.54	39.5	42.5	22.7	4.00	29.9	118	12,100	17.1	1,750	3.79
<b>DID120N</b>	38.10	25.4	22.23	11.11	49.7	53.0	28.2	4.80	35.9	166	17,000	24.5	2,500	5.49
<b>DID140N</b>	44.45	25.4	25.4	12.71	53.6	58.4	31.7	5.60	41.9	215	22,000	32.3	3,300	7.11
<b>DID160N</b>	50.80	31.75	28.58	14.29	63.6	68.2	36.5	6.40	47.8	269	27,500	41.2	4,200	9.82

Roller Chains for Power Transmission

Single Pitch

### • Dimensions of attachment

Chain No.	Pitch <b>P</b>	Attachment A1, K1			Attachment SA1, SK1		Common dimensions		Attachment D		Approx. additional weight per attachment (kg)		
		<b>C</b>	<b>Y</b>	<b>S</b>	<b>C<sub>1</sub></b>	<b>Y<sub>1</sub></b>	<b>B</b>	<b>O</b>	<b>I</b>	<b>L</b>	<b>A,SA</b>	<b>K,SK</b>	<b>D</b>
* <b>DID 25N</b>	6.35	7.15	10.7	4.76	7.94	11.50	5.56	3.4	6.00	9.2	0.0003	0.0006	0.00002
* <b>DID 35N</b>	9.525	9.52	14.4	6.35	9.52	14.70	7.94	3.5	9.52	14.6	0.001	0.002	0.0009
<b>DID 41N</b>	12.70	11.91	17.5	7.14	12.30	17.50	9.53	3.5	9.52	15.4	0.0015	0.003	0.0009
<b>DID 40N</b>	12.70	12.70	17.6	7.92	12.70	17.50	9.53	3.5	9.52	16.8	0.002	0.004	0.001
<b>DID 50N</b>	15.875	15.88	23.0	10.31	15.88	22.60	12.70	5.2	11.91	21.0	0.003	0.006	0.002
<b>DID 60N</b>	19.05	19.05	27.0	11.91	18.26	26.20	15.88	5.2	14.27	25.7	0.006	0.012	0.003
<b>DID 80N</b>	25.40	25.40	34.9	15.88	24.61	34.05	19.05	6.8	19.05	33.9	0.011	0.022	0.007
<b>DID100N</b>	31.75	31.75	43.3	19.84	31.75	42.75	25.40	8.7	23.83	41.9	0.024	0.048	0.012
<b>DID120N</b>	38.10	38.10	53.2	23.02	36.51	50.30	28.58	10.3	28.58	51.4	0.037	0.074	0.02
<b>DID140N</b>	44.45	44.45	61.9	28.58	44.45	62.40	34.92	12.3	33.32	57.8	0.068	0.136	0.03
<b>DID160N</b>	50.80	50.80	69.9	31.75	50.80	68.10	38.10	14.3	38.10	67.4	0.091	0.182	0.045

### • Dimensions of wide attachment

Chain No.	Pitch <b>P</b>	Attachment WA1, WA2, WK1, WK2			Attachment WSA1, WSA2, WSK1, WSK2		Common dimensions			Approx. additional weight per attachment (kg)	
		<b>C</b>	<b>Y</b>	<b>S</b>	<b>C<sub>1</sub></b>	<b>Y<sub>1</sub></b>	<b>O</b>	<b>Bw</b>	<b>Pw</b>	<b>WA,WSA</b>	<b>WK,WSK</b>
<b>DID 40N</b>	12.70	12.70	17.6	7.92	12.70	17.5	4.5	23.0	9.5	0.003	0.006
<b>DID 50N</b>	15.875	15.88	23.0	10.31	15.88	22.6	5.5	28.8	11.9	0.007	0.014
<b>DID 60N</b>	19.05	19.05	27.0	11.91	18.26	26.2	6.6	34.6	14.3	0.012	0.024
<b>DID 80N</b>	25.40	25.40	34.9	15.88	24.61	34.1	9.0	46.1	19.1	0.026	0.052
<b>DID100N</b>	31.75	31.75	43.3	19.84	31.75	42.8	11.0	57.8	23.8	0.051	0.102

Note: 1. Those marked with \* indicate Bushing Chain.

2. The values of the Avg. tensile strength and Max. allowable load are for chain bodies (attachments aren't included).

## Chain Body

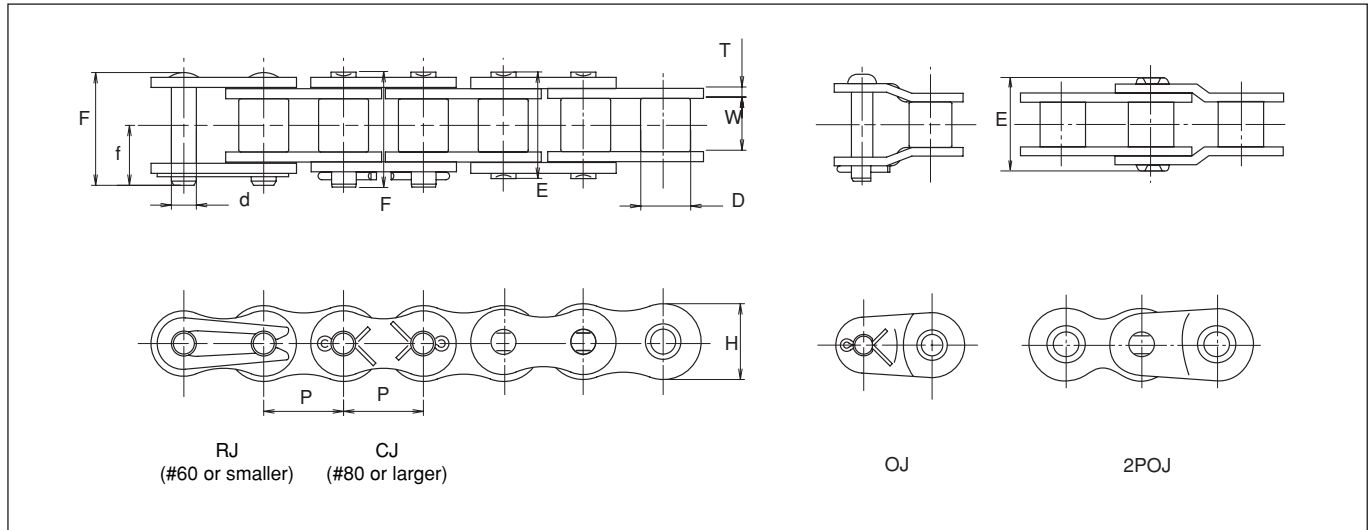

## Attachment

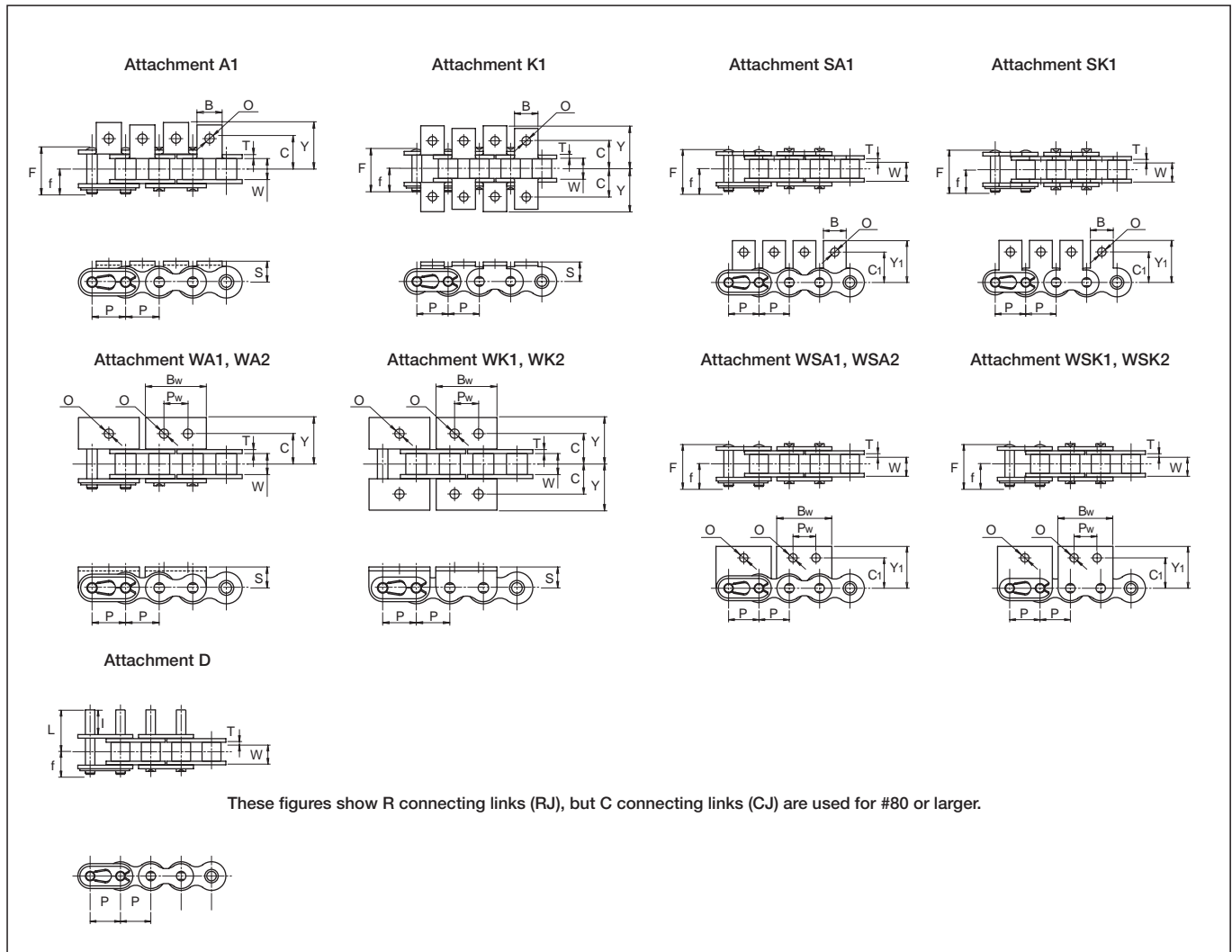

Small Conveyor Chains  
 Single Pitch



## Dimensions of High Guard Chain (Single pitch)

### • Dimensions of Chain Bodies

Unit (mm)

Chain No.	Pitch <b>P</b>	Roller link width <b>W</b>	Roller (bush) dia. <b>D</b>	Pin				Plate		Avg. tensile strength		Max. allowable load		Approx. weight without attachments (kg/m)
				<b>d</b>	<b>E</b>	<b>F</b>	<b>f</b>	<b>T</b>	<b>H</b>	kN	kgf	kN	kgf	
* <b>DID 35E</b>	9.525	4.78	(5.08)	3.59	12.0	13.1	7.3	1.25	9.0	10.2	1,050	2.15	220	0.32
<b>DID 40E</b>	12.70	7.95	7.92	3.97	16.5	17.6	9.5	1.5	12.0	16.6	1,700	3.72	380	0.63
<b>DID 50E</b>	15.875	9.53	10.16	5.09	20.3	21.9	11.6	2.0	15.0	28.4	2,900	6.86	700	1.06
<b>DID 60E</b>	19.05	12.70	11.91	5.96	25.4	26.9	14.3	2.4	18.1	40.2	4,100	9.31	950	1.44
<b>DID 80E</b>	25.40	15.88	15.88	7.94	32.6	35.4	19.0	3.2	24.0	75.0	7,650	14.7	1,500	2.55
<b>DID100E</b>	31.75	19.05	19.05	9.54	39.5	42.5	22.8	4.0	29.9	112.0	11,500	22.5	2,300	3.79
<b>DID120E</b>	38.10	25.40	22.23	11.11	49.7	53.0	28.2	4.8	35.9	157.0	16,100	30.4	3,100	5.49

### • Dimensions of attachment

Chain No.	Pitch <b>P</b>	Attachment A1, K1			Attachment SA1, SK1		Common dimensions		Attachment D		Approx. additional weight per attachment (kg)		
		<b>C</b>	<b>Y</b>	<b>S</b>	<b>C<sub>1</sub></b>	<b>Y<sub>1</sub></b>	<b>B</b>	<b>O</b>	<b>I</b>	<b>L</b>	<b>A,SA</b>	<b>K,SK</b>	<b>D</b>
* <b>DID 35E</b>	9.525	9.52	14.4	6.35	9.52	14.70	7.94	3.5	9.52	14.6	0.001	0.002	0.0009
<b>DID 40E</b>	12.70	12.70	17.6	7.92	12.70	17.50	9.53	3.5	9.52	16.8	0.002	0.004	0.001
<b>DID 50E</b>	15.875	15.88	23.0	10.31	15.88	22.60	12.70	5.2	11.91	21.0	0.003	0.006	0.002
<b>DID 60E</b>	19.05	19.05	27.0	11.91	18.26	26.20	15.88	5.2	14.27	25.7	0.006	0.012	0.003
<b>DID 80E</b>	25.40	25.40	34.9	15.88	24.61	34.05	19.05	6.8	19.05	33.9	0.011	0.022	0.007
<b>DID100E</b>	31.75	31.75	43.3	19.84	31.75	42.75	25.40	8.7	23.83	41.9	0.024	0.048	0.012
<b>DID120E</b>	38.10	38.10	53.2	23.02	36.51	50.30	28.58	10.3	28.58	51.4	0.037	0.074	0.02

### • Dimensions of wide attachment

Chain No.	Pitch <b>P</b>	Attachment WA1, WA2, WK1, WK2			Attachment WSA1, WSA2, WSK1, WSK2		Common dimensions			Approx. additional weight per attachment (kg)	
		<b>C</b>	<b>Y</b>	<b>S</b>	<b>C<sub>1</sub></b>	<b>Y<sub>1</sub></b>	<b>O</b>	<b>Bw</b>	<b>Pw</b>	<b>WA,WSA</b>	<b>WK,WSK</b>
<b>DID 40E</b>	12.70	12.70	17.6	7.92	12.70	17.5	4.5	23.0	9.5	0.003	0.006
<b>DID 50E</b>	15.875	15.88	23.0	10.31	15.88	22.6	5.5	28.8	11.9	0.007	0.014
<b>DID 60E</b>	19.05	19.05	27.0	11.91	18.26	26.2	6.6	34.6	14.3	0.012	0.024
<b>DID 80E</b>	25.40	25.40	34.9	15.88	24.61	34.1	9.0	46.1	19.1	0.026	0.052

Note: 1. Those marked with \* indicate Bushing Chain.

2. The values of the Avg. tensile strength and Max. allowable load are for chain bodies (attachments aren't included).

## Chain Body

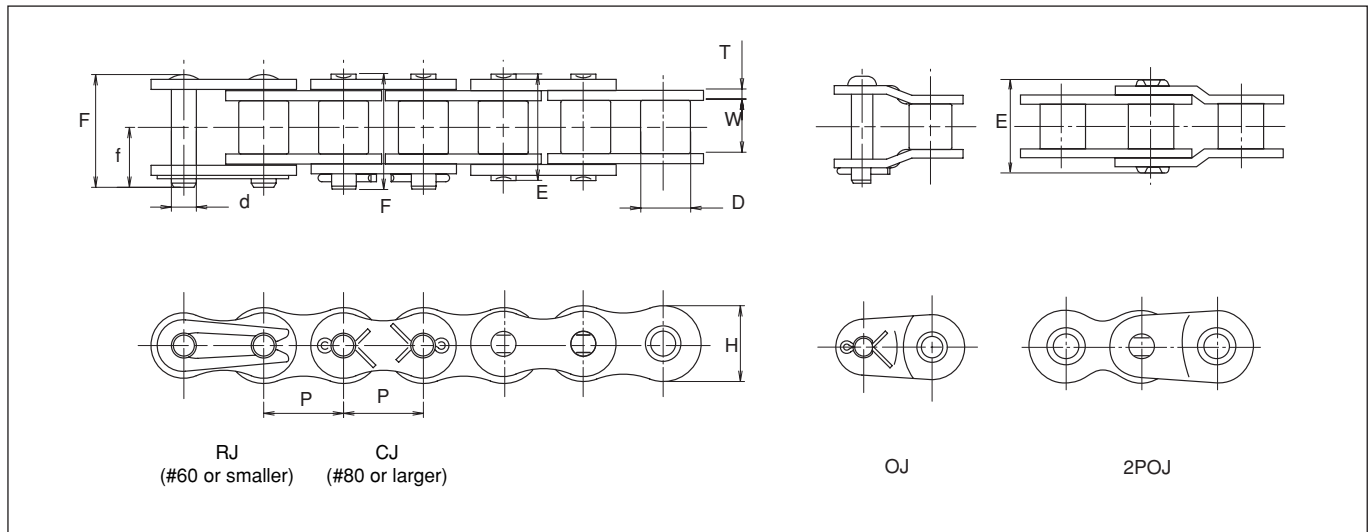

## Attachment

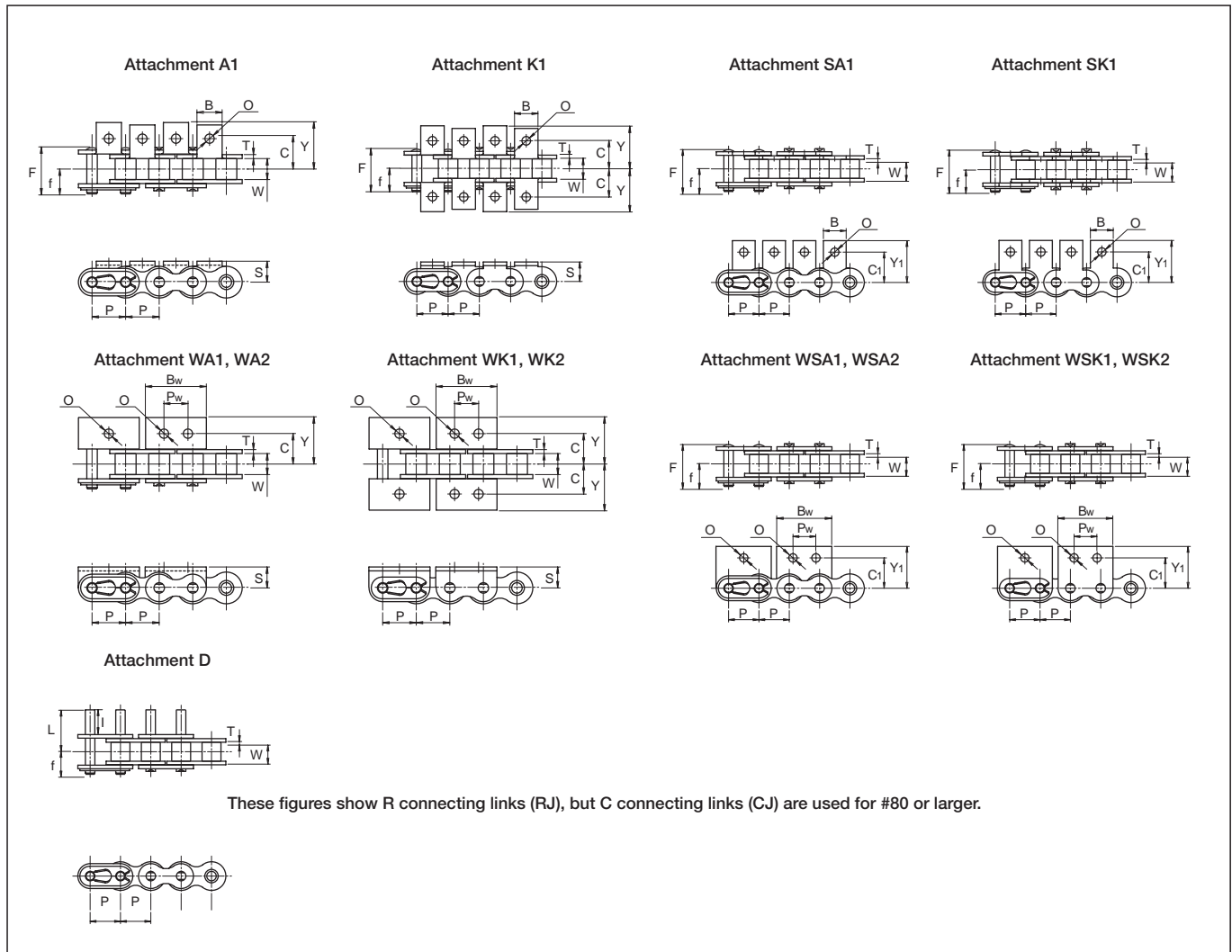



## Dimensions for Double Guard Chain (Single Pitch)

### • Dimensions of Chain Bodies

Unit (mm)

Chain No.	Pitch <b>P</b>	Roller link width <b>W</b>	Roller (bush) dia. <b>D</b>	Pin				Plate		Avg. tensile strength		Max. allowable load		Approx. weight without attachments (kg/m)
				<b>d</b>	<b>E</b>	<b>F</b>	<b>f</b>	<b>T</b>	<b>H</b>	kN	kgf	kN	kgf	
<b>DID 40WG</b>	12.70	7.95	7.92	3.97	16.5	17.6	9.5	1.5	12.0	16.6	1,700	3.72	380	0.63
<b>DID 50WG</b>	15.875	9.53	10.16	5.09	20.3	21.9	11.6	2.0	15.0	28.4	2,900	6.86	700	1.06
<b>DID 60WG</b>	19.05	12.70	11.91	5.96	25.4	26.9	14.3	2.4	18.1	40.2	4,100	9.31	950	1.44
<b>DID 80WG</b>	25.40	15.88	15.88	7.94	32.6	35.4	19	3.2	24.0	75.0	7,650	14.70	1,500	2.55

### • Dimensions of attachment

Chain No.	Pitch <b>P</b>	Attachment A1, K1			Attachment SA1, SK1		Common dimensions		Attachment D		Approx. additional weight per attachment (kg)		
		<b>C</b>	<b>Y</b>	<b>S</b>	<b>C<sub>1</sub></b>	<b>Y<sub>1</sub></b>	<b>B</b>	<b>O</b>	<b>I</b>	<b>L</b>	<b>A,SA</b>	<b>K,SK</b>	<b>D</b>
<b>DID 40WG</b>	12.70	12.70	17.6	7.92	12.70	17.50	9.53	3.5	9.52	16.8	0.002	0.004	0.001
<b>DID 50WG</b>	15.875	15.88	23.0	10.31	15.88	22.60	12.70	5.2	11.91	21.0	0.003	0.006	0.002
<b>DID 60WG</b>	19.05	19.05	27.0	11.91	18.26	26.20	15.88	5.2	14.27	25.7	0.006	0.012	0.003
<b>DID 80WG</b>	25.40	25.40	34.9	15.88	24.61	34.05	19.05	6.8	19.05	33.9	0.011	0.022	0.007

### • Dimensions of wide attachment

Chain No.	Pitch <b>P</b>	Attachment WA1, WA2, WK1, WK2			Attachment WSA1, WSA2, WSK1, WSK2		Common dimensions			Approx. additional weight per attachment (kg)	
		<b>C</b>	<b>Y</b>	<b>S</b>	<b>C<sub>1</sub></b>	<b>Y<sub>1</sub></b>	<b>O</b>	<b>Bw</b>	<b>Pw</b>	<b>WA,WSA</b>	<b>WK,WSK</b>
<b>DID 40WG</b>	12.70	12.70	17.6	7.92	12.70	17.5	4.5	23.0	9.5	0.003	0.006
<b>DID 50WG</b>	15.875	15.88	23.0	10.31	15.88	22.6	5.5	28.8	11.9	0.007	0.014
<b>DID 60WG</b>	19.05	19.05	27.0	11.91	18.26	26.2	6.6	34.6	14.3	0.012	0.024
<b>DID 80WG</b>	25.40	25.40	34.9	15.88	24.61	34.1	9.0	46.1	19.1	0.026	0.052

Note: The values of the Avg. tensile strength and Max. allowable load are for chain bodies (attachments aren't included).

## Chain Body

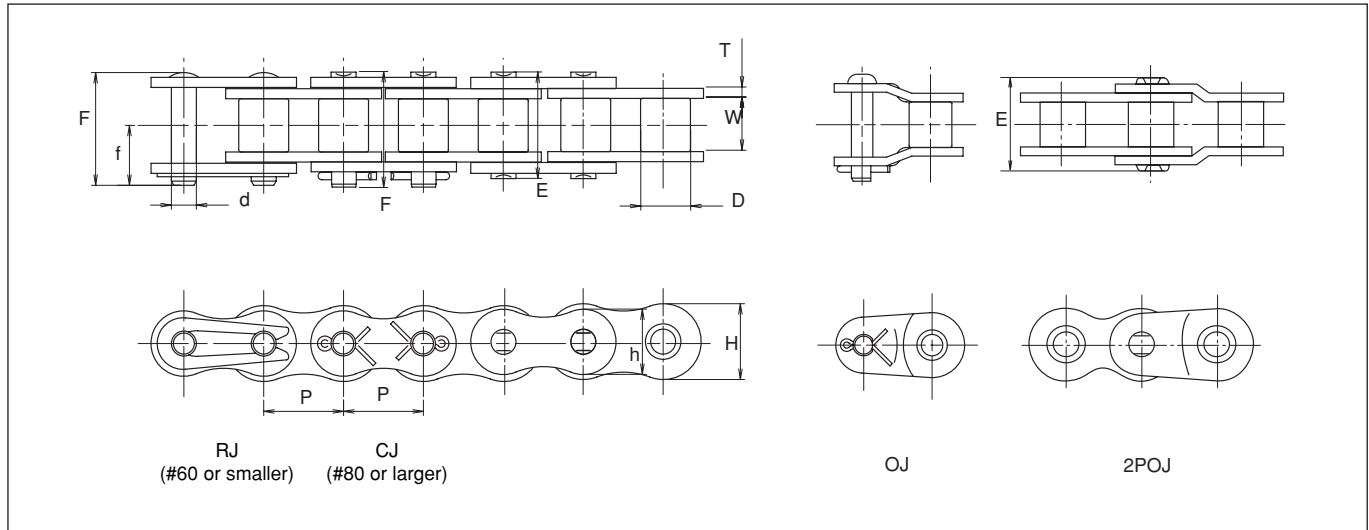

## Attachment

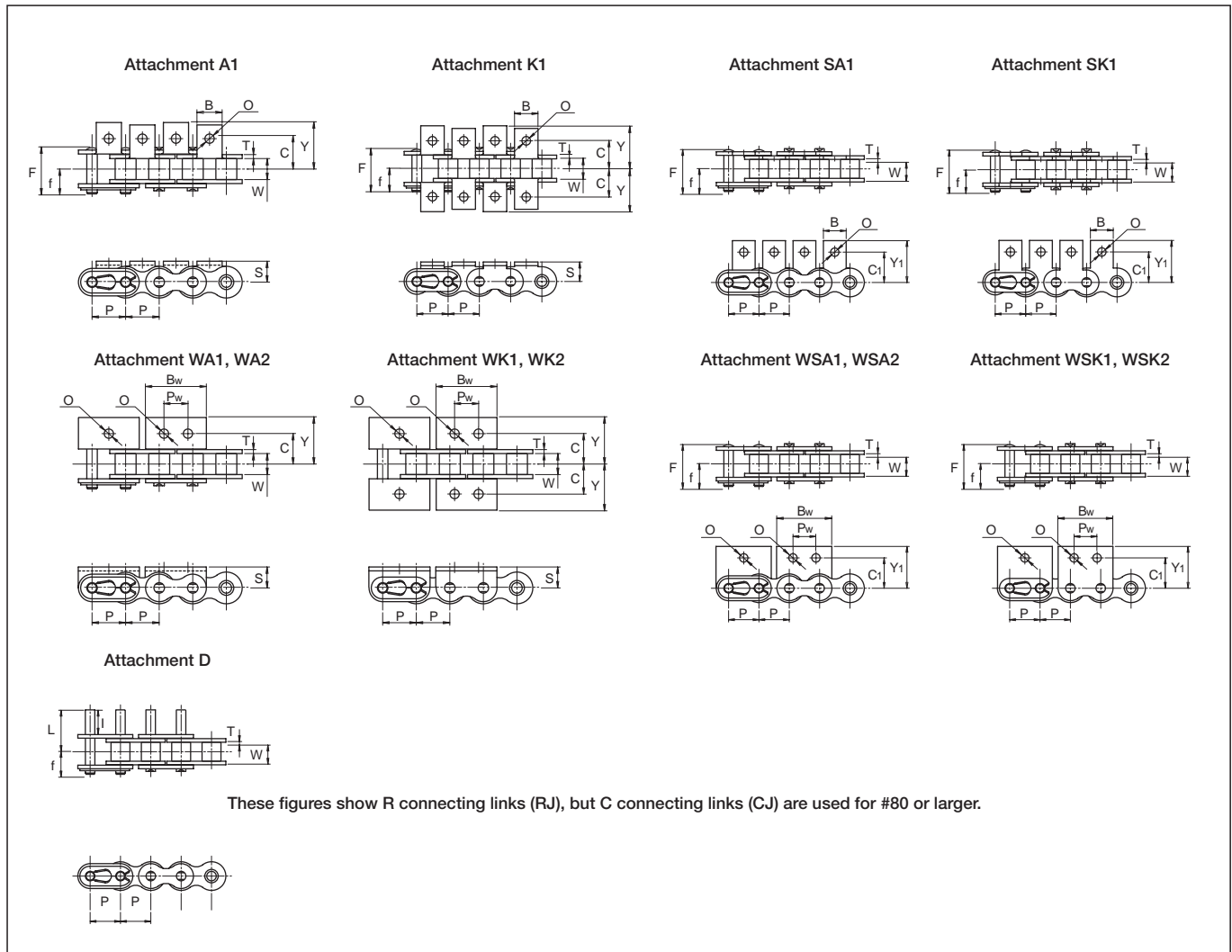

Small Conveyor Chains

Single Pitch





## Dimensions of Stainless Steel Chain (Single pitch)

### • Dimensions of Chain Bodies

Unit (mm)

Chain No.	Pitch <b>P</b>	Roller link width <b>W</b>	Roller (bush) dia. <b>D</b>	Pin				Plate			Avg. tensile strength		Max. allowable load		Approx. weight (kg/m)
				<b>d</b>	<b>E</b>	<b>F</b>	<b>f</b>	<b>T</b>	<b>H</b>	<b>h</b>	kN	kgf	kN	kgf	
* <b>DID 25SS</b>	6.35	3.10	(3.30)	2.30	7.60	—	—	0.75	6.0	5.2	3.33	340	0.117	12	0.13
* <b>DID 35SS</b>	9.525	4.68	(5.08)	3.58	11.80	13.20	7.15	1.27	9.0	7.8	7.55	770	0.264	27	0.34
<b>DID 40SS</b>	12.70	7.85	7.95	3.96	16.30	17.50	9.35	1.50	12.0	10.4	13.3	1,360	0.441	45	0.64
<b>DID 50SS</b>	15.875	9.40	10.16	5.08	20.50	21.60	11.35	2.00	15.0	13.0	20.9	2,130	0.686	70	1.06
<b>DID 60SS</b>	19.05	12.57	11.91	5.95	25.85	27.00	14.10	2.40	18.1	15.6	30.0	3,060	1.07	110	1.56
<b>DID 80SS</b>	25.40	15.75	15.88	7.93	32.50	34.70	18.45	3.20	24.1	20.8	53.4	5,450	1.76	180	2.62
<b>DID100SS</b>	31.75	18.90	19.05	9.53	40.30	42.35	22.20	4.00	30.1	26.0	82.3	8,390	2.54	260	4.13

### • Dimensions of Chain Bodies

Chain No.	Pitch <b>P</b>	Roller link width <b>W</b>	Roller (bush) dia. <b>D<sub>1</sub></b>	Pin				Plate			Avg. tensile strength		Max. allowable tension		Approx. weight (kg/m)
				<b>d</b>	<b>E</b>	<b>F</b>	<b>f</b>	<b>T</b>	<b>H</b>	<b>h</b>	kN	kgf	kN	kgf	
<b>DID 40 SSK</b>	12.70	7.85	7.95	3.96	16.30	17.50	9.35	1.50	12.0	10.4	13.3	1,360	0.686	70	0.64
<b>DID 50 SSK</b>	15.875	9.40	10.16	5.08	20.50	21.60	11.35	2.00	15.0	13.0	20.9	2,130	1.03	105	1.06
<b>DID 60 SSK</b>	19.05	12.57	11.91	5.95	25.85	27.00	14.10	2.40	18.1	15.6	30.0	3,060	1.57	160	1.56
<b>DID 80 SSK</b>	25.40	15.75	15.88	7.93	32.50	34.70	18.45	3.20	24.1	20.8	53.4	5,450	2.65	270	2.62
<b>DID 100 SSK</b>	31.75	18.90	19.05	9.53	40.30	42.35	22.20	4.00	30.1	26.0	82.3	8,390	3.82	390	4.13

### • Dimensions of attachment

Chain No.	Pitch <b>P</b>	Attachment A1, K1			Attachment SA1, SK1		Common dimensions		Attachment D		Approx. additional weight per attachment (kg)		
		<b>C</b>	<b>Y</b>	<b>S</b>	<b>C<sub>1</sub></b>	<b>Y<sub>1</sub></b>	<b>B</b>	<b>O</b>	<b>I</b>	<b>L</b>	<b>A,SA</b>	<b>K,SK</b>	<b>D</b>
* <b>DID 25SS</b>	6.35	7.1	10.7	4.8	7.95	11.7	5.6	2.8	6.00	13.90	0.0003	0.0006	0.0002
* <b>DID 35SS</b>	9.525	9.5	14.3	6.4	9.50	14.7	7.9	2.8	9.52	21.60	0.0008	0.0016	0.0008
<b>DID 40SS.SSK</b>	12.70	12.7	18.0	7.9	12.70	17.6	9.6	3.6	9.52	25.80	0.002	0.004	0.001
<b>DID 50SS.SSK</b>	15.875	15.9	22.9	10.3	15.90	22.6	12.8	5.2	11.91	32.30	0.003	0.006	0.002
<b>DID 60SS.SSK</b>	19.05	19.1	27.7	11.9	18.30	26.4	16.1	5.2	14.27	40.00	0.007	0.014	0.003
<b>DID 80SS.SSK</b>	25.40	25.4	35.2	15.9	24.60	34.1	19.0	6.8	19.05	52.35	0.013	0.026	0.007

### • Dimensions of wide attachment

Chain No.	Pitch <b>P</b>	Attachment WA1, WA2, WK1, WK2			Attachment WSA1, WSA2, WSK1, WSK2		Common dimensions			Approx. additional weight per attachment (kg)		
		<b>C</b>	<b>Y</b>	<b>S</b>	<b>C<sub>1</sub></b>	<b>Y<sub>1</sub></b>	<b>O</b>	<b>Bw</b>	<b>Pw</b>	<b>WA,WSA</b>	<b>WK,WSK</b>	
* <b>DID 25SS</b>	6.35	-	-	-	-	-	-	-	-	-	-	-
* <b>DID 35SS</b>	9.525	-	-	-	-	-	-	-	-	-	-	-
<b>DID 40SS.SSK</b>	12.70	12.7	18.0	7.9	12.70	17.5	3.6	24.2	12.70	0.003	0.006	
<b>DID 50SS.SSK</b>	15.875	15.9	22.9	10.3	15.90	22.6	5.2	30.2	15.88	0.007	0.014	
<b>DID 60SS.SSK</b>	19.05	19.1	27.7	11.9	18.30	26.2	5.2	36.1	19.05	0.012	0.024	
<b>DID 80SS.SSK</b>	25.40	25.4	35.2	15.9	24.60	34.1	6.8	48.0	25.40	0.026	0.052	

Note: 1. Those marked with \* indicate Bushing Chain.

2. The values of the Avg. tensile strength and Max. allowable load are for chain bodies (attachments aren't included).

## Chain Body

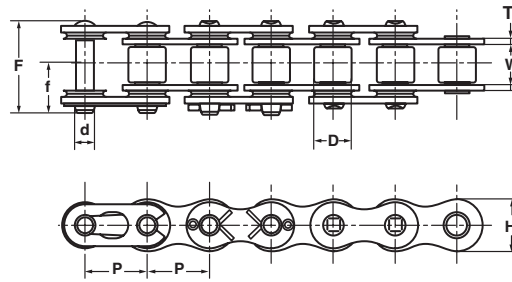

RJ (#60 or smaller), CJ (#80 or larger)

## Attachment

### Attachment A1

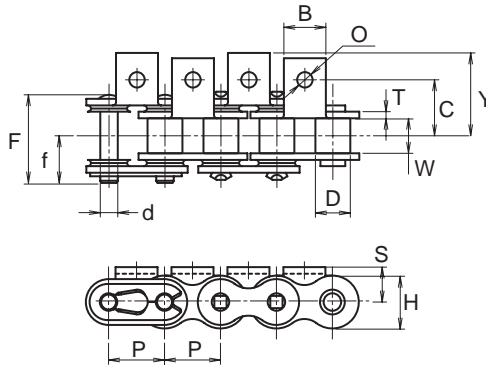

### Attachment K1

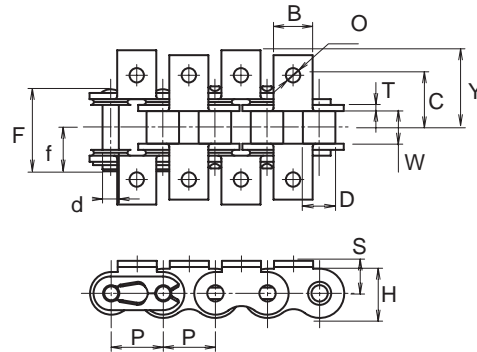

### Attachment SA1

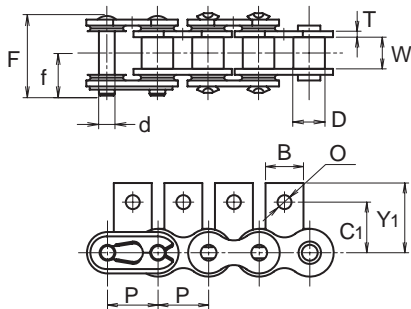

### Attachment SK1

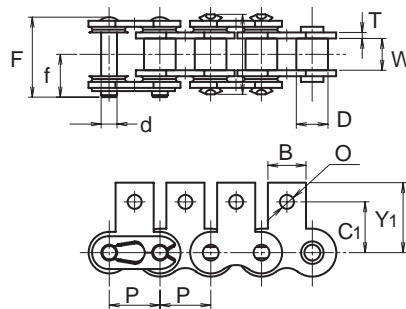

### Attachment D

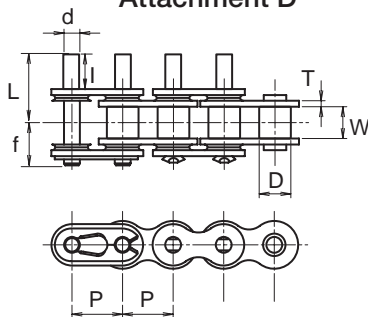

These figures show R connecting links (RJ), but C connecting links (CJ) are used for #80 or larger.



## Dimensions of Stainless Steel X-Ring Chains (Single pitch)

### • Dimensions of Chain Bodies

Unit (mm)

Chain No.	Pitch <b>P</b>	Roller link width <b>W</b>	Roller (bush) dia. <b>D</b>	Pin			Plate		Avg. tensile strength		Max. allowable load		Approx. weight kg/m
				<b>d</b>	<b>F</b>	<b>f</b>	<b>T</b>	<b>H</b>	kN	kgf	kN	kgf	
<b>DID40SSLT</b>	12.70	7.95	7.92	3.96	20.0	10.7	1.5	12.0	13.3	1,360	0.41	45	0.67
<b>DID50SSLT</b>	15.875	9.53	10.16	5.08	23.9	12.8	2.0	15.0	20.9	2,130	0.68	70	1.08
<b>DID60SSLT</b>	19.05	12.70	11.91	5.95	30.0	16.0	2.4	18.1	30.0	3,060	1.07	110	1.62
<b>DID80SSLT</b>	25.40	15.88	15.88	7.93	38.5	20.9	3.2	24.0	53.4	5,450	1.76	180	2.83

### • Dimensions of attachment

Chain No.	Pitch <b>P</b>	Attachment A1, K1			Attachment SA1, SK1		Common dimensions		Attachment D		Approx. additional weight per attachment (kg)		
		<b>C</b>	<b>Y</b>	<b>S</b>	<b>C<sub>1</sub></b>	<b>Y<sub>1</sub></b>	<b>B</b>	<b>O</b>	<b>I</b>	<b>L</b>	<b>A,SA</b>	<b>K,SK</b>	<b>D</b>
<b>DID40SSLT</b>	12.70	12.70	18.8	7.92	12.70	17.50	9.6	3.5	9.52	17.9	0.002	0.004	0.001
<b>DID50SSLT</b>	15.875	15.88	24.1	10.31	15.88	22.60	12.8	5.2	11.91	22.1	0.003	0.006	0.002
<b>DID60SSLT</b>	19.05	19.05	28.4	11.91	18.26	26.20	16.1	5.2	14.27	27.2	0.006	0.012	0.003
<b>DID80SSLT</b>	25.40	25.40	36.6	15.88	24.61	34.05	19.0	6.8	19.05	35.4	0.011	0.022	0.007

Note: The values of the Avg. tensile strength and Max. allowable load are for chain bodies (attachments aren't included).

## Chain Body

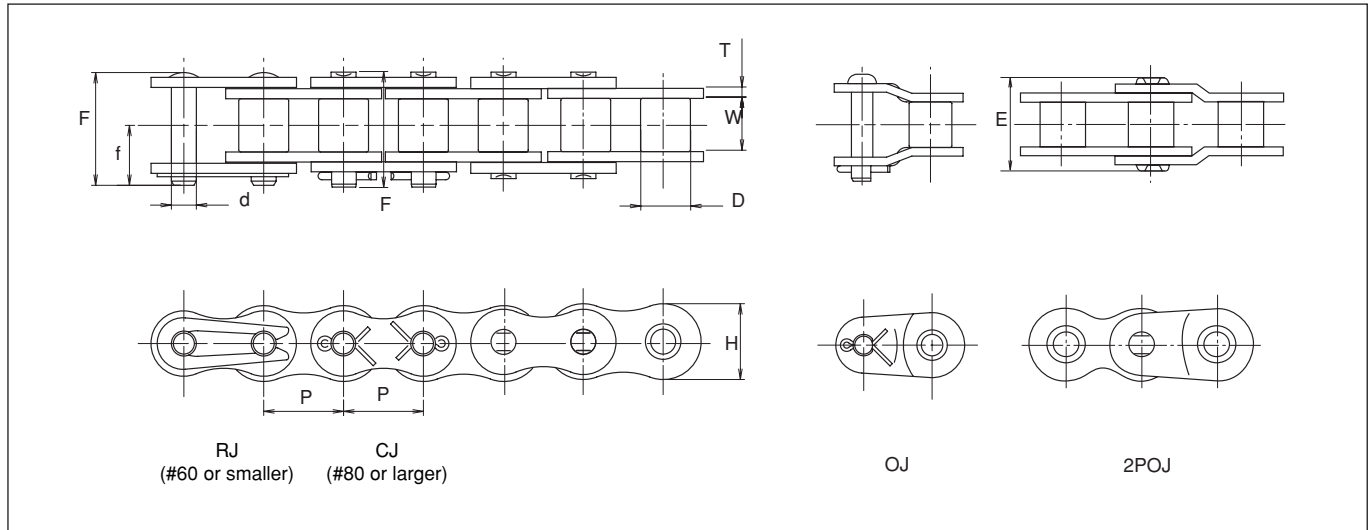

## Attachment

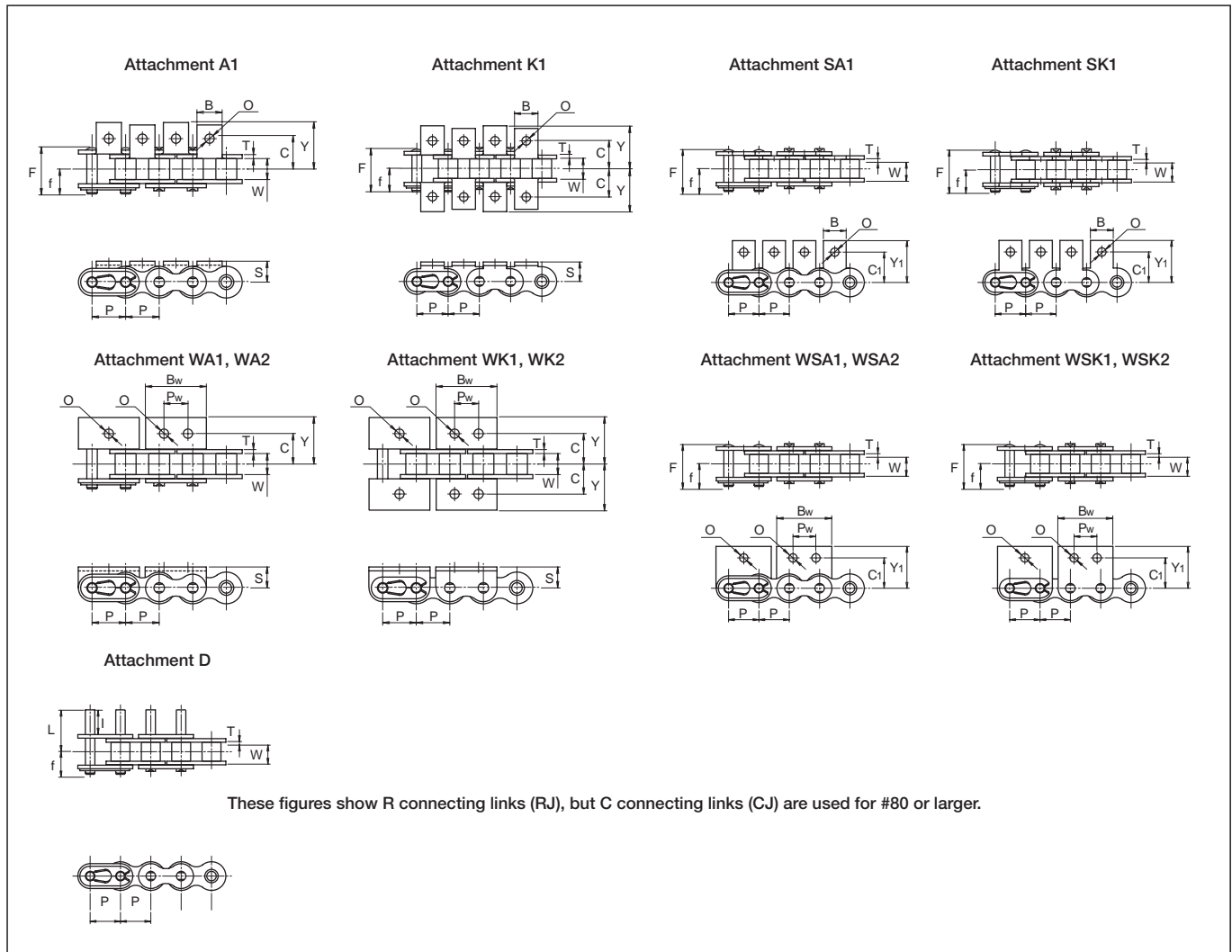

Small Conveyor Chains  
 Single Pitch



## Dimensions of Low Temperature Resistant Chain (Single pitch)

### • Dimensions of Chain Bodies

Unit (mm)

Chain No.	Pitch <b>P</b>	Roller link width <b>W</b>	Roller (bush) dia. <b>D</b>	Pin			Plate		Max. allowable load						Approx. weight without attachments (kg/m)
				<b>d</b>	<b>F</b>	<b>f</b>	<b>T</b>	<b>H</b>	+80°C~-10°C		-11°C~-30°C		-31°C~-40°C		
									kN	kgf	kN	kgf	kN	kgf	
<b>DID 40TK</b>	12.70	7.95	7.92	3.97	17.6	9.5	1.5	12.0	3.72	380	2.54	260	2.15	220	0.63
<b>DID 50TK</b>	15.875	9.53	10.16	5.09	21.9	11.6	2.0	15.0	6.86	700	4.80	490	3.92	400	1.06
<b>DID 60TK</b>	19.05	12.70	11.91	5.96	26.9	14.3	2.4	18.1	9.31	950	6.47	660	5.39	550	1.44
<b>DID 80TK</b>	25.40	15.88	15.88	7.94	35.4	19.0	3.2	24.0	14.70	1,500	10.29	1,050	8.53	870	2.55
<b>DID100TK</b>	31.75	19.05	19.05	9.54	42.5	22.8	4.0	29.9	22.55	2,300	15.78	1,610	13.04	1,330	3.79
<b>DID120TK</b>	38.10	25.40	22.23	11.11	53.0	28.2	4.8	35.9	30.40	3,100	21.28	2,170	17.55	1,790	5.49
<b>DID140TK</b>	44.45	25.40	25.40	12.71	58.4	31.6	5.6	41.9	40.20	4,100	28.14	2,870	23.24	2,370	7.11
<b>DID160TK</b>	50.80	31.75	28.58	14.29	68.2	36.4	6.4	47.8	52.95	5,400	37.06	3,780	30.69	3,130	9.82

### • Dimensions of attachment



























































Chain No.	Pitch <b>P</b>	Attachment A1, K1			Attachment SA1, SK1		Common dimensions		Attachment D		Approx. additional weight per attachment (kg)		
		<b>C</b>	<b>Y</b>	<b>S</b>	<b>C<sub>1</sub></b>	<b>Y<sub>1</sub></b>	<b>B</b>	<b>O</b>	<b>I</b>	<b>L</b>	<b>A,SA</b>	<b>K,SK</b>	<b>D</b>
<b>DID 40TK</b>	12.70	12.70	17.6	7.92	12.70	17.50	9.53	3.5	9.52	16.8	0.002	0.004	0.001
<b>DID 50TK</b>	15.875	15.88	23.0	10.31	15.88	22.60	12.70	5.2	11.91	21.0	0.003	0.006	0.002
<b>DID 60TK</b>	19.05	19.05	27.0	11.91	18.26	26.20	15.88	5.2	14.27	25.7	0.006	0.012	0.003
<b>DID 80TK</b>	25.40	25.40	34.9	15.88	24.61	34.05	19.05	6.8	19.05	33.9	0.011	0.022	0.007
<b>DID100TK</b>	31.75	31.75	43.3	19.84	31.75	42.75	25.40	8.7	23.83	41.9	0.024	0.048	0.012
<b>DID120TK</b>	38.10	38.10	53.2	23.02	36.51	50.30	28.58	10.3	28.58	51.4	0.037	0.074	0.020
<b>DID140TK</b>	44.45	44.45	61.9	28.58	44.45	62.40	34.92	12.3	33.32	57.8	0.068	0.136	0.030
<b>DID160TK</b>	50.80	50.80	69.9	31.75	50.80	68.10	38.10	14.3	38.10	67.4	0.091	0.182	0.045

### • Dimensions of wide attachment

Chain No.	Pitch <b>P</b>	Attachment WA1, WA2, WK1, WK2			Attachment WSA1, WSA2, WSK1, WSK2		Common dimensions			Approx. additional weight per attachment (kg)	
		<b>C</b>	<b>Y</b>	<b>S</b>	<b>C<sub>1</sub></b>	<b>Y<sub>1</sub></b>	<b>O</b>	<b>Bw</b>	<b>Pw</b>	<b>WA,WSA</b>	<b>WK,WSK</b>
<b>DID 40TK</b>	12.70	12.70	17.6	7.92	12.70	17.5	4.5	23.0	9.5	0.003	0.006
<b>DID 50TK</b>	15.875	15.88	23.0	10.31	15.88	22.6	5.5	28.8	11.9	0.007	0.014
<b>DID 60TK</b>	19.05	19.05	27.0	11.91	18.26	26.2	6.6	34.6	14.3	0.012	0.024
<b>DID 80TK</b>	25.40	25.40	34.9	15.88	24.61	34.1	9.0	46.1	19.1	0.026	0.052
<b>DID100TK</b>	31.75	31.75	43.3	19.84	31.75	42.8	11.0	57.8	23.8	0.051	0.102

Note: The values of the Avg. tensile strength and Max. allowable load are for chain bodies (attachments aren't included).

## Conveyor Chain with Standard Attachments Series (Double Pitch)

Name	Wear Resistance Chain Series					
	Standard Roller Chain	Solid Bushing (T), (D)	DH- $\alpha$ (DHA)	O-Ring(LD) X-Ring(LX)	Sintered Bushing Roller Chain (UR), (URN)	Nickel Plate (N)
						
Features	<ul style="list-style-type: none"> <li>① Use of high precision solid bushing</li> <li>② Suitable for circumstances requiring wear resistance slightly better than standard chains</li> <li>③ Wear life improved by 1.2 to 4 times of standard chains</li> </ul>	<ul style="list-style-type: none"> <li>① Ultra hardening coated pin surface</li> <li>② Suitable for circumstances where foreign substance contamination or extreme oil degradation occurs</li> <li>③ Wear life improved by 1.2 to 7 times of standard chains</li> </ul>	<ul style="list-style-type: none"> <li>① Grease filled between pins and bushes</li> <li>② Top product of the Wear Resistance Chains that can be used for any condition</li> <li>③ Wear life improved by 5 to 20 times of standard chains</li> </ul>	<ul style="list-style-type: none"> <li>① Sintered alloy used for bushes</li> <li>② Long life chain for low-speed and light load operation</li> <li>③ Wear life improved by 5 times of standard chains</li> </ul>	<ul style="list-style-type: none"> <li>① Specialized nickel coating</li> <li>② Suitable for circumstances requiring a clean impression and neat appearance</li> <li>③ Withstands salt breeze and acidic conditions</li> </ul>	
Functions	 	  	   	     <p>※ LX = -10°C ~ -120°C, LD = -10°C ~ -80°C,</p>	  	    
Main uses	   	     	        	     	     	

### Conveyor Chain with Standard Attachments Series (Double Pitch): Chain No. and Codes

Chain No.	Standard	Solid Bushing	DHA	O-Ring/X-Ring	Sintered Bushing	Nickel Plating	Double Guard
DID C2040	○	D	DHA	LX	UR,URN	N	WG
DID C2042	○	D	DHA	LX	UR,URN	N	WG
DID C2050	○	D	DHA	LX	UR,URN	N	WG
DID C2052	○	D	DHA	LX	UR,URN	N	WG
DID C2060H	○	D	DHA	LX	UR,URN	N	WG
DID C2062H	○	D	DHA	LX	UR,URN	N	WG
DID C2080H	○	D	-	-	UR,URN	N	WG
DID C2082H	○	D	-	-	UR,URN	N	WG
DID C2100H	○	D	-	-	-	N	-
DID C2102H	○	D	-	-	-	N	-
DID C2120H	○	D	-	-	-	N	-
DID C2122H	○	D	-	-	-	N	-
DID C2160H	○	D	-	-	-	N	-
DID C2162H	○	D	-	-	-	N	-

Note: 1. Standard chains are available for those indicated with ○.  
 2. Although the ones marked with - aren't standard products, consult us.  
 3. Heat resistance (URF) chains are available for Sintered Bushing Roller Chain.



Environment Resistance Chain Series					Name
Double Guard Chain (WG)	Hi-Guard Chain (E)	Stainless Steel Chain		Stainless Steel X-Ring Chain (SSLT)	
		(SS)	(SSK)		
<ul style="list-style-type: none"> <li>① Approx. twice more corrosion resistant compared to the High Guard Chain</li> <li>② Suitable for circumstances with mild acidic or mild alkaline solutions</li> <li>③ Downsizing is possible compared to Stainless Steel Chains</li> </ul>	<ul style="list-style-type: none"> <li>① High corrosion resistance coating</li> <li>② Suitable for circumstances both indoors and outdoors where long term resistance to rusting is required</li> <li>③ Excellent resistance to corrosion, salt and rusting</li> </ul>	<ul style="list-style-type: none"> <li>① 18-8 stain</li> <li>② Suitable for circumstances exposed to chemical agents, water and high temperature</li> <li>③ Best corrosion resistance and heat resistance</li> </ul>	<ul style="list-style-type: none"> <li>① 18-8 stain (plate) + precipitation hardened line (pin/ bush/ roller)</li> <li>② Suitable for circumstances with chemical agents, water and/or high temperature</li> <li>③ 1.5 times more tension allowance compared to SS type</li> </ul>	<ul style="list-style-type: none"> <li>① Superb wear resistance</li> <li>② Outstanding cost performance</li> <li>③ Significant reduction in friction-loss</li> </ul>	Features
					Functions
					Main uses

※1. Consult us when using the chain for hanging.  
 ※2. Consult us before using.

	Hi-Guard	Stainless Steel		Stainless Steel X-Ring Chain
	<b>E</b>	<b>SS</b>	<b>SSK</b>	<b>SSLT</b>
	<b>E</b>	<b>SS</b>	<b>SSK</b>	<b>-</b>
	<b>E</b>	<b>SS</b>	<b>SSK</b>	<b>SSLT</b>
	<b>E</b>	<b>SS</b>	<b>SSK</b>	<b>-</b>
	<b>E</b>	<b>SS</b>	<b>SSK</b>	<b>SSLT</b>
	<b>E</b>	<b>SS</b>	<b>SSK</b>	<b>-</b>
	<b>E</b>	<b>-</b>	<b>-</b>	<b>SSLT</b>
	<b>E</b>	<b>-</b>	<b>-</b>	<b>-</b>
	<b>E</b>	<b>-</b>	<b>-</b>	<b>-</b>
	<b>E</b>	<b>-</b>	<b>-</b>	<b>-</b>
	<b>E</b>	<b>-</b>	<b>-</b>	<b>-</b>
	<b>E</b>	<b>-</b>	<b>-</b>	<b>-</b>
	<b>E</b>	<b>-</b>	<b>-</b>	<b>-</b>
	<b>E</b>	<b>-</b>	<b>-</b>	<b>-</b>

Roller Chains for Power Transmission  
 Double Pitch

## Double pitch chain

In general, conveyor chains are operated for longer distances and at lower speeds than transmission chains. Accordingly, even though the pins, bushings and rollers are left unchanged, and the plate pitch is doubled to reduce the number of sprocket teeth engaged with the chain to half, the wear of pins, bushings and rollers is small since the chain speed is low. DID Double Pitch Chains, conform to ANSI standard and "Ultimate Life Chain Series" and "Environment Resistant Chain Series", as are single pitch chains are also available. For information for sprockets, see "Sprockets for double pitch chains" on P.172.

Small Conveyor Chains



Double Pitch

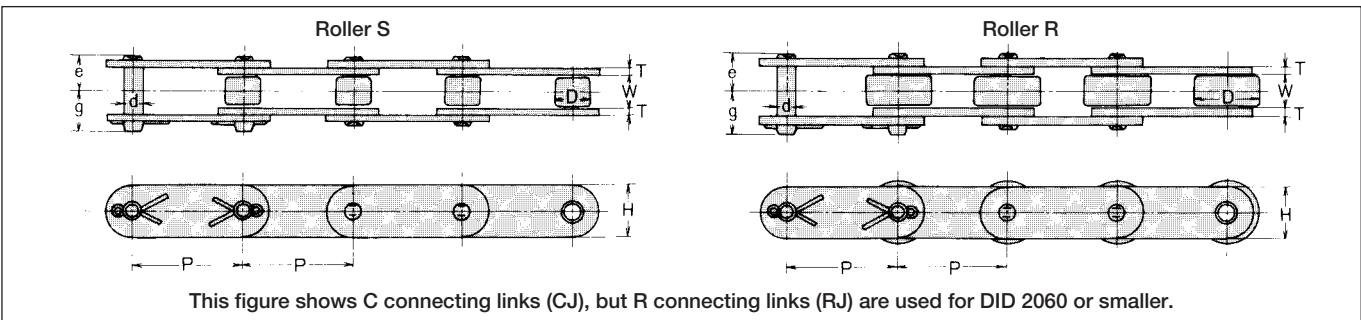

## Double pitch chain with resin rollers

This is a DID Double Pitch Chain with R Roller made of resin, which generates less noise and lighter weight compared with steel rollers. Thus, the chain is suitable for a conveyor system designed to operate quietly and convey light-weight articles. Since the components other than rollers are made of steel, the average tensile strength of a resin roller chain is the same as that of a steel roller chain. However, the "maximum allowable load" of the chain should be kept lower, as shown in the following table, to prevent damage to the plastic rollers by the pressure from the engagement with sprockets.

The "Allowable load of resin rollers" refers to the allowable load acting when conveyed articles press the resin rollers traveling on the floor surface such as guid rails.

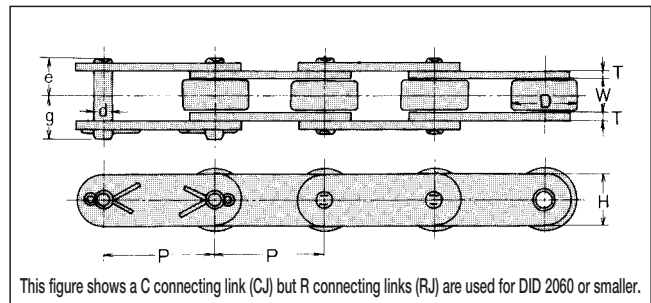

Chain No.	Roller material	Specification of chain components excluding rollers	Max. allowable load		Max. allowable load of resin roller		Weight (kg/m)	Allowable operational temperature
			kN	kgf	kN	kgf		
<b>DID C2042</b>	Resin (polyacetal)	3 variations are available. ● Standard steel ● Rustless type (nickel plated) ● Stainless steel	0.44	45	0.19	20	0.51	-10°C ~80°C
<b>DID C2052</b>			0.68	70	0.29	30	0.85	
<b>DID C2062H</b>			1.03	105	0.49	50	1.46	
<b>DID C2082H</b>			1.76	180	0.88	90	2.58	

Note: Ask us for the delivery time.

## Large roller (R) and small rollers (S)

Since double pitch chains are frequently used for conveying products on a horizontal floor, chains designed for this purpose have increased roller diameter equal to that of single pitch chains of the same pitch for increased load capacity and lower traveling resistance. These rollers with larger outer diameter are called "large rollers", and the regular rollers are called "small rollers".

In this catalog, large rollers are expressed as R Roller, and small rollers as S Roller.

## Designation of double pitch chains

A double pitch chain is designated, as in the following example, based on the nominal number of the single pitch chain it is based on.

## Cautions for selection and use

Cautions are described in "Calculation of Chain Tension". See P.212.

## Connecting links

For the connecting links of double pitch chains of all sizes, the connecting plates and connecting pins are clearance-fitted. For DIDC2060H or smaller, the spring clip type (R connecting link) is standard. For DIDC2080H or larger, the cotter type (C connecting link) is standard. Connecting links with an attachment, top roller or side roller are also available.

### [Type indication]

Indicates that the thickness of plates is larger by one size, that is, equal to the thickness of the plates of DID100. If there is no symbol, the thickness is equal to the thickness of the plates of DID80.

**DID C 2 082 H**

082 indicates that the base is DID80, and that rollers with a large outer diameter (Roller R) are used. In the case of regular rollers, 080 is stated here.

Indicates that the chain is a double pitch chain.

Indicates that the chain is for a conveyor system.

Indication that the chain is a DAIDO product.

## Sprockets for Double Pitch Chain

Sprockets for double pitch chains are different from sprockets of single pitch chains. Therefore, use the sprockets shown on P.173. However, since chains are to some extent unaffected by difference in the engagement with sprockets, the sprockets of single pitch chains may be used for double pitch chains with larger number of teeth. Recommended sprockets are outlined below.

Number of teeth of double pitch sprocket	Recommended sprocket
9 or less	Avoid using a sprocket with nine or fewer teeth if possible, since the noise is greater and the vibration shortens the life of the chain and equipment.
9.5 to 14  (Example) For DIDC2050 chain  If a sprocket with 13 operating teeth is necessary, adopt a DID50 hob for 26 teeth or preferably 27 teeth. From the table at the bottom left on P.173, $Dp=4.1786 \times 31.75 = 132.67$ (since 26 teeth mean 13 operating teeth), or $PCD=4.3362 \times 31.75 = 137.67$ (since 27 teeth mean 13.5 operating teeth). (In the above formulas, 31.75 is the chain pitch of DIDC2050.)	<p>When the number of teeth is 9.5 to 14, use a hob for the base single pitch chain, and cut the sprocket teeth to achieve the <math>D_p</math> shown in the left table on P.173.</p> <p>Make the number of cut teeth double the intended operating teeth of the double pitch sprocket, or odd-numbered teeth larger than this by one. With odd-numbered teeth, the operating teeth alter with each revolution of the sprocket, enhancing sprocket durability.</p> <p>(In general, the <math>D_p</math> of the sprocket for a double pitch chain obtained by teeth cut using a hob for a single pitch chain is larger than the <math>D_p</math> of the sprocket for a single pitch chain with the same number of teeth.)</p> <p>When the number of teeth is in this range, do not use the sprocket for a single pitch chain. The wear life of the chain becomes about one half of a chain where a correct sprocket is used. (For example, if a double pitch chain is engaged with a single pitch sprocket with 22 teeth, it is equivalent to a chain elongated by about 1.0% from the beginning.)</p>
15 or more	When the number of teeth is 15 or more, the sprocket for a single pitch chain can be used practically without any problem. Of course, the number of teeth of the single pitch sprocket should be double the number of teeth of the double pitch sprocket. Preferably use odd-numbered teeth by adding one more.

Small roller (Roller S)

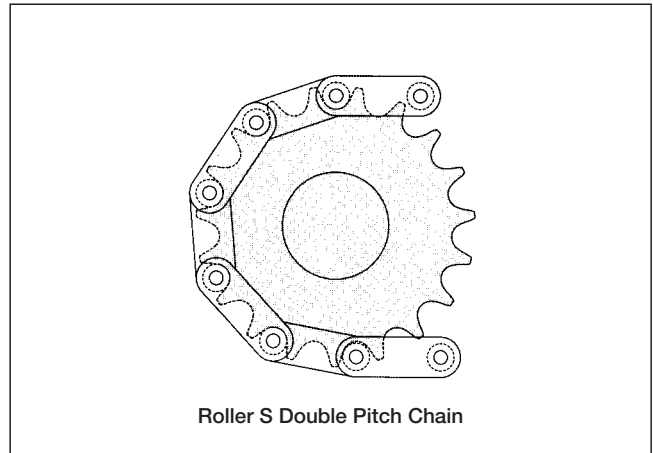

The above illustration shows a Roller S Double Pitch Chain engaged with a sprocket with 19 teeth for single pitch chain. The number of operating teeth for the double pitch chain is 9.5.

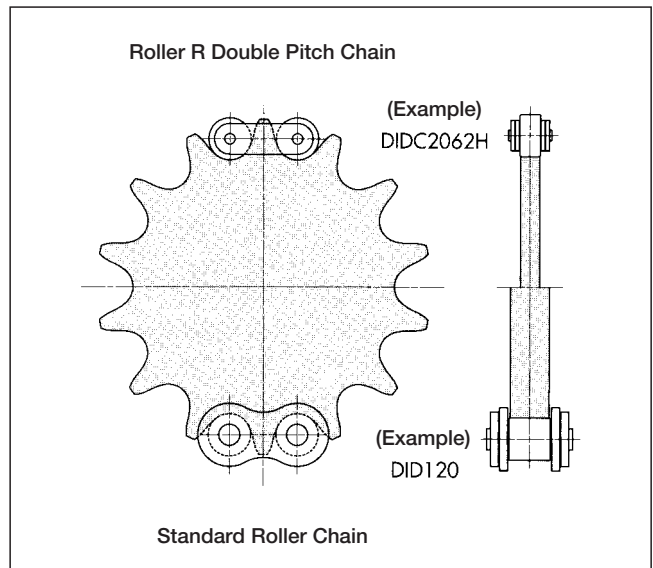

The above illustration shows a Roller R Double Pitch Chain and Standard Roller Chain with the same pitch engaged with a sprocket. It shows that the sprocket is different in thickness only. No single pitch chain sprocket is available for using differing chains. Consult us should you need such a sprocket.

Small Conveyor Chains

Double Pitch

# Dimensions of Sprocket for Double Pitch Chain

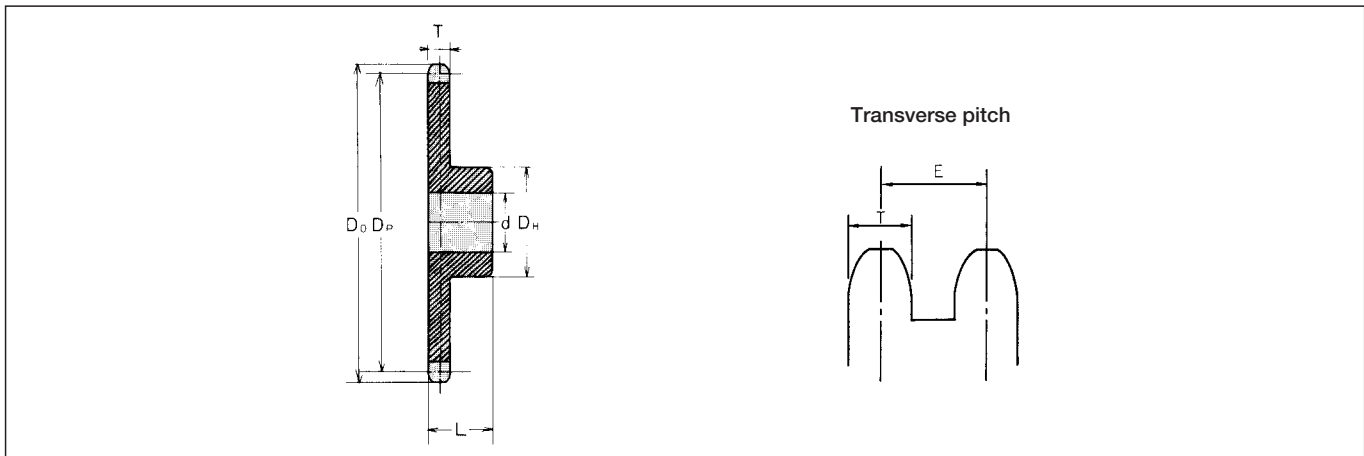

## Roller S

Unit (mm)

Size	No. of teeth	Operating teeth	Pitch circle dia. Dp	Outer dia. Do	Tooth thickness T	Transverse pitch E	Shaft bore dia. d	Hub Dia. DH	Hub Length L	Approx. weight (kg)	Material
DID C2040	19	9 1/2	78.23	84	7.0	14.4	14	32	54	22	0.58
DID C2050	19	9 1/2	97.78	105	8.4	18.1	15	40	65	28	1.00
DID C2060H	19	9 1/2	117.34	126	11.3	26.2	17	45	70	40	1.80
	21	10 1/2	129.26	138	11.3	26.2	17	50	80	40	2.25
	23	11 1/2	141.22	150	11.3	26.2	17	50	80	40	2.50
	25	12 1/2	153.20	162	11.3	26.2	17	50	80	40	2.75
DID C2080H	19	9 1/2	156.45	167	14.1	32.6	22	60	90	40	3.40
DID C2100H	19	9 1/2	195.58	209	17.0	39.1	26	75	107	50	6.10

Note: 1. Tooth end is hardened.  
2. P dia refers to prepared bore diameter.

Pitch circle diameter (Dp) is generally calculated by the following formula using the number of operating teeth (Z) that engage with a double pitch chain.

$$D_p = K_p \times P$$

Kp: Coefficient of pitch circle diameter (refer to the table given below)

P: Nominal pitch of double pitch chain

Operating teeth Z	Coefficient of pitch circle dia. Kp	Operating teeth Z	Coefficient of pitch circle dia. Kp
5	1.7013	11	3.5495
5 1/2	1.8497	11 1/2	3.7065
6	2.0000	12	3.8637
6 1/2	2.1518	12 1/2	4.0211
7	2.3048	13	4.1786
7 1/2	2.4586	13 1/2	4.3362
8	2.6131	14	4.4940
8 1/2	2.7682	14 1/2	4.6518
9	2.9238		
9 1/2	3.0798		
10	3.2361		
10 1/2	3.3926		

## Roller R

Unit (mm)

Size	No. of teeth	Operating teeth	Pitch circle dia. Dp	Outer dia. Do	Tooth thickness T	Transverse pitch E	Shaft bore dia. d	Hub Dia. DH	Hub Length L	Approx. weight (kg)	Material
DID C2042	10	10	82.20	93	7.0	14.4	15	34	56	25	0.63
	11	11	90.16	102	7.0	14.4	15	34	56	25	0.72
	12	12	98.14	108	7.0	14.4	15	34	56	25	0.75
	13	13	106.14	118	7.0	14.4	15	42	63	25	0.97
	14	14	114.15	127	7.0	14.4	15	42	63	25	1.00
	15	15	122.17	135	7.0	14.4	15	43	63	28	1.15
	16	16	130.20	143	7.0	14.4	15	43	63	28	1.25
	17	17	138.23	151	7.0	14.4	17	45	70	28	1.45
	18	18	146.27	159	7.0	14.4	17	45	70	28	1.53
	19	19	154.32	167	7.0	14.4	17	45	70	28	1.65
	20	20	162.37	176	7.0	14.4	17	45	70	28	2.00
DID C2052	10	10	102.75	116	8.4	18.1	17	45	70	28	1.30
	11	11	112.70	127	8.4	18.1	17	45	70	28	1.32
	12	12	122.67	138	8.4	18.1	17	45	70	28	1.45
	13	13	132.67	148	8.4	18.1	17	45	70	28	1.55
	14	14	142.68	158	8.4	18.1	17	45	70	28	1.80
	15	15	152.71	168	8.4	18.1	17	45	70	28	1.90
	16	16	162.74	179	8.4	18.1	17	45	70	28	2.15
	17	17	172.79	189	8.4	18.1	20	50	85	35	2.50
	18	18	182.84	199	8.4	18.1	20	55	90	40	3.00
	19	19	192.90	209	8.4	18.1	20	55	90	40	3.20
	20	20	202.96	220	8.4	18.1	20	55	90	40	3.40
DID C2062H	10	10	123.30	140	11.3	26.2	17	50	80	45	2.40
	11	11	135.24	153	11.3	26.2	17	50	80	45	2.60
	12	12	147.21	165	11.3	26.2	17	50	80	45	2.80
	13	13	159.20	177	11.3	26.2	21	50	85	45	3.00
	14	14	171.22	190	11.3	26.2	21	50	85	45	3.70
	15	15	183.25	202	11.3	26.2	21	50	85	45	3.80
	16	16	195.29	214	11.3	26.2	21	50	85	50	4.00
	17	17	207.35	227	11.3	26.2	23	55	90	55	4.90
	18	18	219.41	239	11.3	26.2	23	55	90	55	5.30
	19	19	231.48	251	11.3	26.2	23	55	90	55	5.60
	20	20	243.55	263	11.3	26.2	23	55	90	55	6.00
DID C2082H	11	11	180.31	204	14.6	32.6	25	75	107	45	4.80
DID C2102H	11	11	225.39	254	17.6	39.1	30	80	117	56	7.90

Note: 1. Teeth end is not hardened.  
2. P dia refers to prepared bore diameter.  
3. Ask us for the delivery time.



## Standard Attachments

For DID Small Conveyor Chain, various links are available for coupling and attaching custom devices directly to the chains. These links are called attachments. The following standard attachments are available.

### Types and names of standard attachments

DID Standard Attachments include five kinds for single pitch chains and five kinds for double pitch chains as illustrated below. Standard attachments for respective chain sizes are listed on the following page.

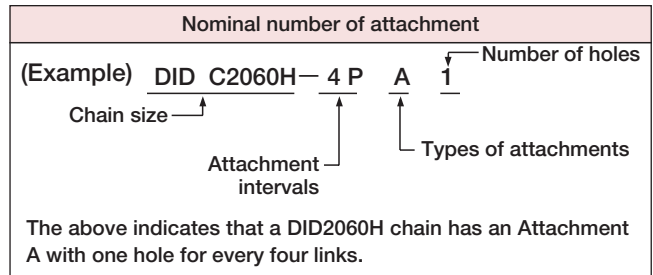

Attachment **A** (Bent attachment on one side)

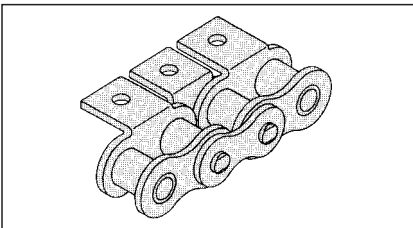

Attachment **SA** (Straight attachment on one side)

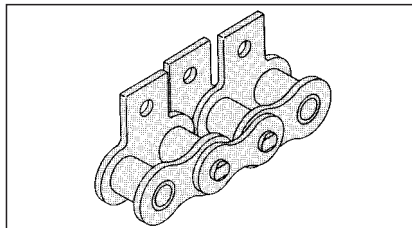

Attachment **D** (Extended pin)

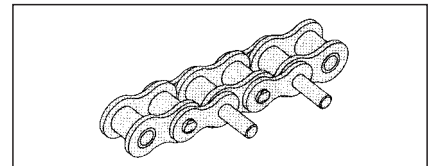

Above figure shows D1 (an extended pin set on every two links)

Attachment **K** (Bent attachment on each side)

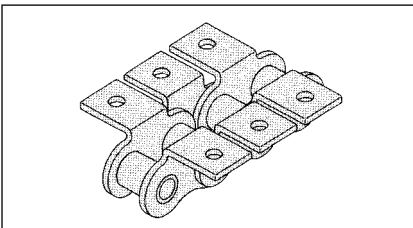

Attachment **SK** (Straight attachment on each side)

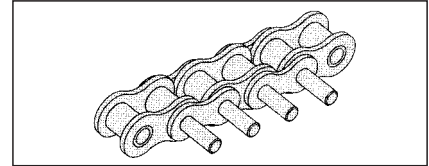
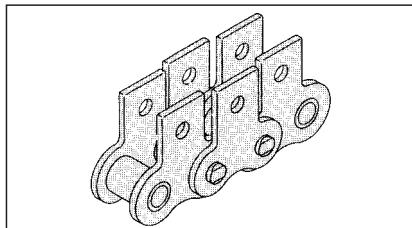

Above figure shows D3 (an extended pin set on every link)

(Ref : D pin with a particular length is called "Attachment LP" (abbreviation of Long Pin))

### Examples of standard attachments

Installation of a U slot with Attachment **SK1**

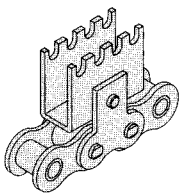

Installation of a dog with Attachment **SK1**

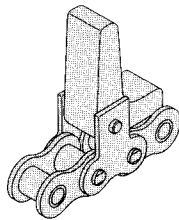

Installation of a pin with Attachment **K1**

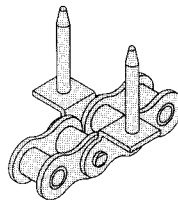

Installation of a bucket with Attachment **K1**

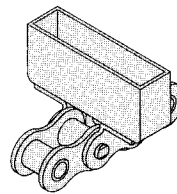

Installation of a bucket with Attachment **K1**

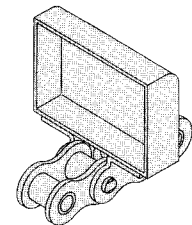

Installation of a strut with Attachment **K1**

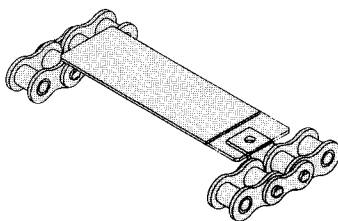

Conveyance of a long article by two strands of Attachment **SA1**

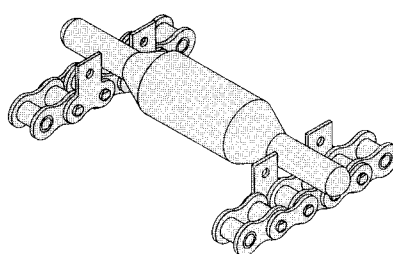

Installation of an L fitting with Attachment **D3**

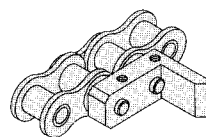

Installation of a dog with Attachment **D1**

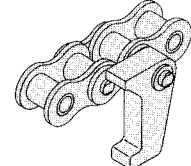



# Standard Roller Chain Attachment

○ : Stock product  
 △ : Made-to-order

		DID standard attachment										
		Standard attachment										
		One-side bent		Both sides bent		One side straight		Both sides straight		Extended pin		
		A1	A2	K1	K2	SA1	SA2	SK1	SK2	D1	D3	
Double pitch	Roller S	DID C2040	△	○	△	○	△	△	△	△	△	△
		DID C2050	△	○	△	○	△	△	△	△	△	△
		DID C2060H	△	○	△	○	△	△	△	△	△	△
		DID C2080H	△	○	△	○	△	△	△	△	△	△
		DID C2100H	△	△	△	△	△	△	△	△	△	△
		DID C2120H	△	△	△	△	△	△	△	△	△	△
Roller R		DID C2160H	△	△	△	△	△	△	△	△	△	△
		DID C2042	△	△	△	△	△	△	△	△	△	△
		DID C2052	△	△	△	△	△	△	△	△	△	△
		DID C2062H	△	△	△	△	△	△	△	△	△	△
		DID C2082H	△	△	△	△	△	△	△	△	△	△
		DID C2102H	△	△	△	△	△	△	△	△	△	△
	DID C2122H	△	△	△	△	△	△	△	△	△	△	
	DID C2162H	△	△	△	△	△	△	△	△	△	△	

Roller Chains for Power Transmission

Double Pitch

## Indication of specially arranged chains with attachments

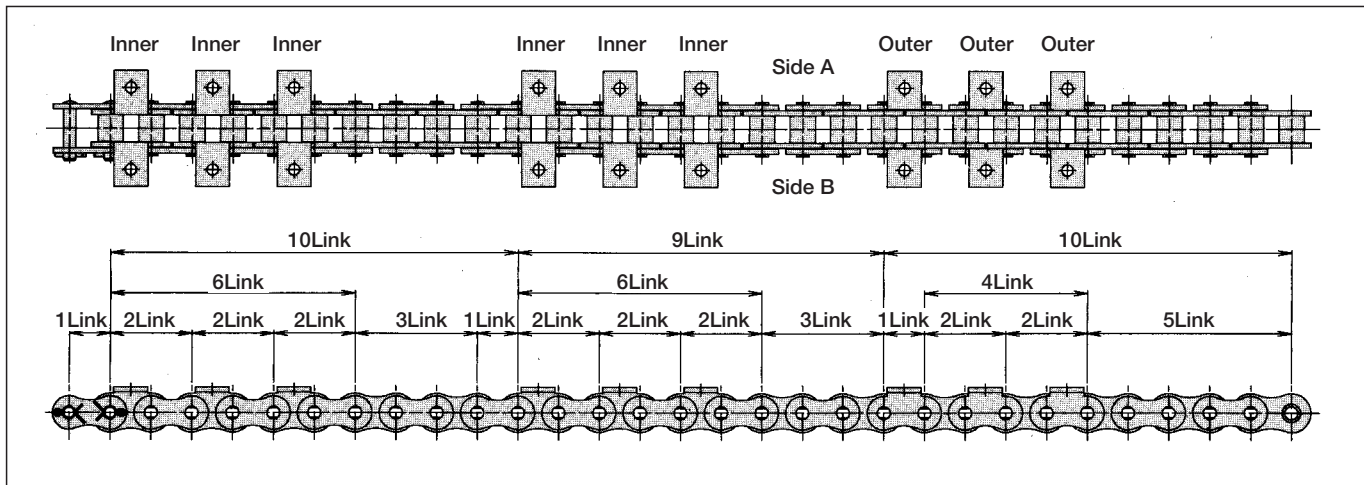

A specially arranged chain with Attachment K1s, as in the above illustration, is indicated as follows:

$$CJ + (K1 \text{ inner} + PL) \times 3 + 3LL + PL + (K1 \text{ inner} + PL) \times 3 + 3LL + K1 \text{ outer} + (RL + K1 \text{ outer}) \times 2 + 5LL$$

"CJ" stands for a C connecting link; "K1 inner", an inner link Attachment K1; "PL", an outer link; "3LL", three links from an inner link to an inner link; "K1 outer", an outer link Attachment K1; and "RL", an inner link.

A "+" sign means "connect", and an "×" sign means "repeat". (For one-side attachments such as Attachment A and Attachment SA, the position of attachment plates is on side A in the above illustration.)

Consult us for other styles not mentioned here.

Note: When attaching attachments to every even-number link, they are attached to outer links, unless specified.

## Chain Body

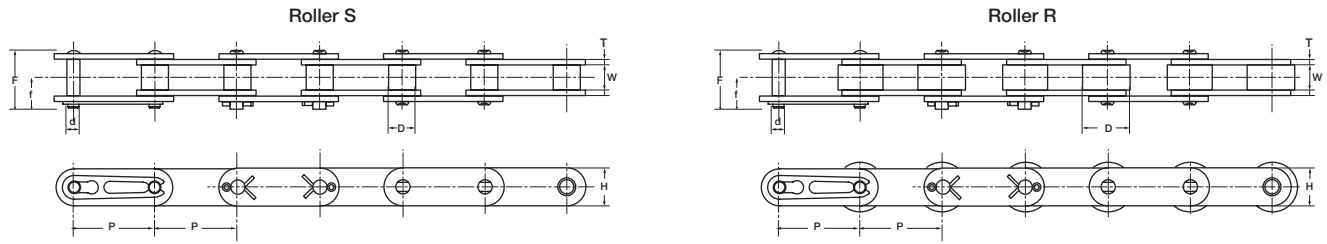

Use R connecting links (RJ) for #2060 or smaller and C connecting links (CJ) for #2080 or larger.

## Attachment

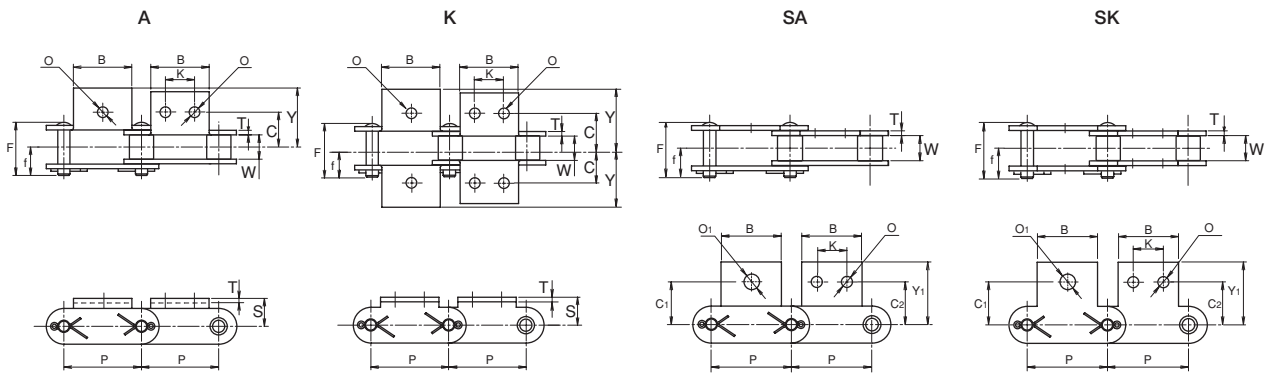

This figure shows C connecting links (CJ) but R connecting links (RJ) are used for #2060 or smaller.

## Dimensions of Standard Roller Chain (Double pitch)

### • Dimensions of Chain Bodies

Unit (mm)

Chain No.	Pitch <b>P</b>	Roller link width <b>W</b>	Roller (bush) dia. <b>D</b>	Pin			Plate		Avg. tensile strength		Max. allowable load		Approx. weight without attachments (kg/m)
				<b>d</b>	<b>F</b>	<b>f</b>	<b>T</b>	<b>H</b>	kN	kgf	kN	kgf	
<b>DID C2040</b> <b>DID C2042</b>	25.40	7.95	7.92 15.88	3.97	17.6	9.5	1.5	11.7	17.0	1,740	2.64	270	0.49 0.86
<b>DID C2050</b> <b>DID C2052</b>	31.75	9.53	10.16 19.05	5.09	21.9	11.6	2.0	15.1	28.7	2,930	4.41	450	0.84 1.32
<b>DID C2060H</b> <b>DID C2062H</b>	38.10	12.70	11.91 22.23	5.96	30.1	16.1	3.2	17.2	40.2	4,100	6.47	660	1.45 2.17
<b>DID C2080H</b> <b>DID C2082H</b>	50.80	15.88	15.88 28.58	7.94	38.7	20.6	4.0	23.3	68.6	7,000	11.2	1,150	2.46 3.53
<b>DID C2100H</b> <b>DID C2102H</b>	63.50	19.05	19.05 39.68	9.54	45.8	24.4	4.8	28.8	112	11,500	18.6	1,900	3.60 5.81
<b>DID C2120H</b> <b>DID C2122H</b>	76.20	25.40	22.23 44.45	11.11	56.5	29.9	5.6	33.8	156	16,000	25.5	2,600	5.09 8.09
<b>DID C2160H</b> <b>DID C2162H</b>	101.60	31.75	28.58 57.15	14.29	71.6	38.2	7.1	47.4	259	26,500	42.1	4,300	8.91 13.60

Note: The values of the avg. tensile strength and max. allowable load are for the chains (attachments aren't included).

### • Dimensions of attachment

Chain No.	Pitch <b>P</b>	Attachment											Approx. additional weight per attachment (kg)	
		<b>S</b>	<b>C</b>	<b>Y</b>	<b>Y<sub>1</sub></b>	<b>C<sub>1</sub></b>	<b>C<sub>2</sub></b>	<b>K</b>	<b>B</b>	<b>O</b>	<b>O<sub>1</sub></b>	<b>T</b>	<b>A,SA</b>	<b>K,SK</b>
<b>DID C2040</b> <b>DID C2042</b>	25.40	9.13	12.70	19.4	19.8	11.11	13.50	9.53	19.1	3.5	5.2	1.5	0.003	0.006
<b>DID C2050</b> <b>DID C2052</b>	31.75	11.11	15.88	24.4	24.6	14.29	15.88	11.91	23.8	5.2	6.8	2.0	0.006	0.012
<b>DID C2060H</b> <b>DID C2062H</b>	38.10	14.68	21.43	33.3	30.6	17.46	19.05	14.29	28.6	5.2	8.7	3.2	0.016	0.032
<b>DID C2080H</b> <b>DID C2082H</b>	50.80	19.05	27.78	40.8	40.5	22.23	25.40	19.05	38.1	6.8	10.3	4.0	0.034	0.068
<b>DID C2100H</b> <b>DID C2102H</b>	63.50	23.42	33.34	51.6	50.4	28.58	31.75	23.81	47.6	8.7	14.3	4.8	0.064	0.128
<b>DID C2120H</b> <b>DID C2122H</b>	76.20	27.78	39.69	62.9	59.9	33.34	37.31	28.58	57.1	10.3	16.0	5.6	0.108	0.216
<b>DID C2160H</b> <b>DID C2162H</b>	101.60	36.51	52.39	79.0	78.6	44.45	50.80	38.10	76.2	14.3	22.0	7.1	0.246	0.492

Note: Attachments with one hole are indicated as SA1, SK1, A1, K1, and those with two holes are indicated as SA2, SK2, A2, K2.

## Chain Body

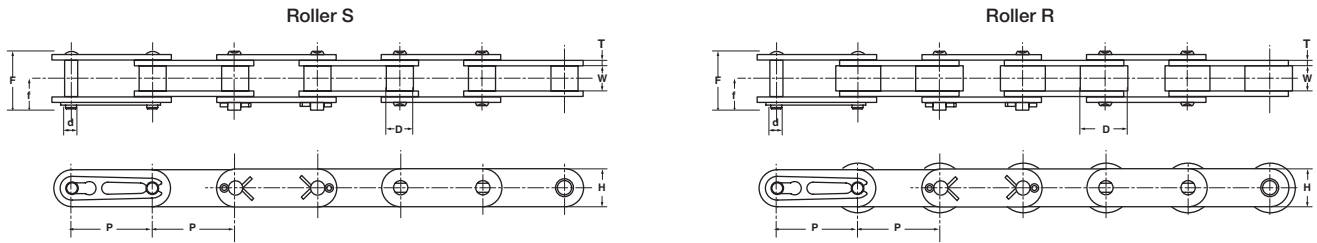

Use R connecting links (RJ) for #2060 or smaller and C connecting links (CJ) for #2080 or larger.

## Attachment

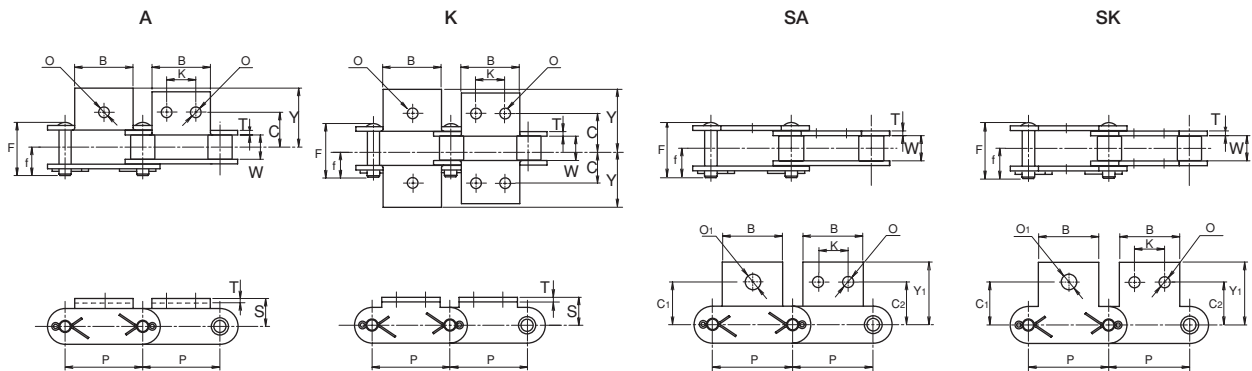

This figure shows C connecting links (CJ) but R connecting links (RJ) are used for #2060 or smaller.



## Dimensions of Long Life Chain (Double pitch)

### • Dimensions of Chain Bodies

Unit (mm)

Chain No.	Pitch <b>P</b>	Roller link width <b>W</b>	Roller (bush) dia. <b>D</b>	Pin			Plate		Avg. tensile strength		Max. allowable load		Approx. weight without attachments (kg/m)
				<b>d</b>	<b>F</b>	<b>f</b>	<b>T</b>	<b>H</b>	kN	kgf	kN	kgf	
<b>DIDC2040D</b> <b>DIDC2042D</b>	25.40	7.95	7.92 15.88	3.97	17.6	9.5	1.5	11.7	17.0	1,740	2.64	270	0.49 0.86
<b>DIDC2050D</b> <b>DIDC2052D</b>	31.75	9.53	10.16 19.05	5.09	21.9	11.6	2.0	15.1	28.7	2,930	4.41	450	0.84 1.32
<b>DIDC2060HD</b> <b>DIDC2062HD</b>	38.10	12.70	11.91 22.23	5.96	30.1	16.1	3.2	17.2	40.2	4,100	6.47	660	1.45 2.17
<b>DIDC2080HD</b> <b>DIDC2082HD</b>	50.80	15.88	15.88 28.58	7.94	38.7	20.6	4.0	23.3	68.6	7,000	11.2	1,150	2.46 3.53
<b>DIDC2100HD</b> <b>DIDC2102HD</b>	63.50	19.05	19.05 39.68	9.54	45.8	24.4	4.8	28.8	112	11,500	18.6	1,900	3.60 5.81
<b>DIDC2120HD</b> <b>DIDC2122HD</b>	76.20	25.40	22.23 44.45	11.11	56.5	29.9	5.6	33.8	156	16,000	25.5	2,600	5.09 8.09
<b>DIDC2160HD</b> <b>DIDC2162HD</b>	101.60	31.75	28.58 57.15	14.29	71.6	38.2	7.1	47.4	259	26,500	42.1	4,300	8.91 13.60

Note: The values of the avg. tensile strength and max. allowable load are for the chains (attachments aren't included).

### • Dimensions of attachment

Chain No.	Pitch <b>P</b>	Attachment											Approx. additional weight per attachment (kg)	
		<b>S</b>	<b>C</b>	<b>Y</b>	<b>Y<sub>1</sub></b>	<b>C<sub>1</sub></b>	<b>C<sub>2</sub></b>	<b>K</b>	<b>B</b>	<b>O</b>	<b>O<sub>1</sub></b>	<b>T</b>	<b>A,SA</b>	<b>K,SK</b>
<b>DIDC2040D</b> <b>DIDC2042D</b>	25.40	9.13	12.70	19.4	19.8	11.11	13.50	9.53	19.1	3.5	5.2	1.5	0.003	0.006
<b>DIDC2050D</b> <b>DIDC2052D</b>	31.75	11.11	15.88	24.4	24.6	14.29	15.88	11.91	23.8	5.2	6.8	2.0	0.006	0.012
<b>DIDC2060HD</b> <b>DIDC2062HD</b>	38.10	14.68	21.43	33.3	30.6	17.46	19.05	14.29	28.6	5.2	8.7	3.2	0.016	0.032
<b>DIDC2080HD</b> <b>DIDC2082HD</b>	50.80	19.05	27.78	40.8	40.5	22.23	25.40	19.05	38.1	6.8	10.3	4.0	0.034	0.068
<b>DIDC2100HD</b> <b>DIDC2102HD</b>	63.50	23.42	33.34	51.6	50.4	28.58	31.75	23.81	47.6	8.7	14.3	4.8	0.064	0.128
<b>DIDC2120HD</b> <b>DIDC2122HD</b>	76.20	27.78	39.69	62.9	59.9	33.34	37.31	28.58	57.1	10.3	16.0	5.6	0.108	0.216
<b>DIDC2160HD</b> <b>DIDC2162HD</b>	101.60	36.51	52.39	79.0	78.6	44.45	50.80	38.10	76.2	14.3	22.0	7.1	0.246	0.492

Note: Attachments with one hole are indicated as SA1, SK1, A1, K1, and those with two holes are indicated as SA2, SK2, A2, K2.

## Chain Body

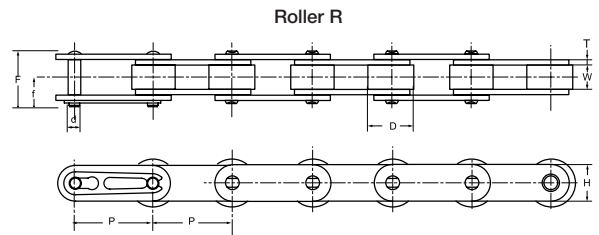
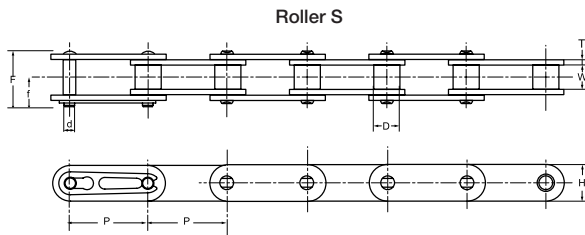

## Attachment

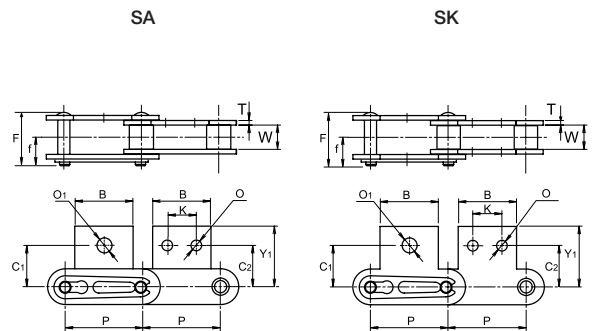
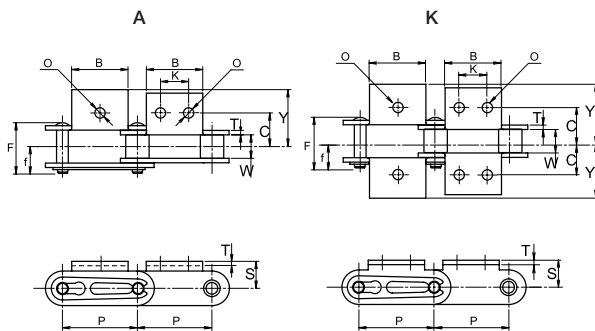





## Dimensions of DH- $\alpha$ Chain (Double pitch)

### • Dimensions of Chain Bodies

Unit (mm)

Chain No.	Pitch <b>P</b>	Roller link width <b>W</b>	Roller (bush) dia. <b>D</b>	Pin			Plate		Avg. tensile strength		Max. allowable load		Approx. weight without attachments (kg/m)
				<b>d</b>	<b>F</b>	<b>f</b>	<b>T</b>	<b>H</b>	kN	kgf	kN	kgf	
<b>DIDC2040DHA</b> <b>DIDC2042DHA</b>	25.40	7.95	7.92 15.88	3.97	17.6	9.5	1.5	11.7	17.0	1,740	2.64	270	0.49 0.86
<b>DIDC2050DHA</b> <b>DIDC2052DHA</b>	31.75	9.53	10.16 19.05	5.09	21.9	11.6	2.0	15.1	28.7	2,930	4.41	450	0.84 1.32
<b>DIDC2060HDHA</b> <b>DIDC2062HDHA</b>	38.10	12.70	11.91 22.23	5.96	30.1	16.1	3.2	17.2	40.2	4,100	6.47	660	1.45 2.17

Note: The values of the avg. tensile strength and max. allowable load are for the chains (attachments aren't included).

### • Dimensions of attachment

Chain No.	Pitch <b>P</b>	Attachment											Approx. additional weight per attachment (kg)	
		<b>S</b>	<b>C</b>	<b>Y</b>	<b>Y<sub>1</sub></b>	<b>C<sub>1</sub></b>	<b>C<sub>2</sub></b>	<b>K</b>	<b>B</b>	<b>O</b>	<b>O<sub>1</sub></b>	<b>T</b>	<b>A,SA</b>	<b>K,SK</b>
<b>DIDC2040DHA</b> <b>DIDC2042DHA</b>	25.40	9.13	12.70	19.4	19.8	11.11	13.50	9.53	19.1	3.5	5.2	1.5	0.003	0.006
<b>DIDC2050DHA</b> <b>DIDC2052DHA</b>	31.75	11.11	15.88	24.4	24.6	14.29	15.88	11.91	23.8	5.2	6.8	2.0	0.006	0.012
<b>DIDC2060HDHA</b> <b>DIDC2062HDHA</b>	38.10	14.68	21.43	33.3	30.6	17.46	19.05	14.29	28.6	5.2	8.7	3.2	0.016	0.032

Note: 1. Attachments with one hole are indicated as SA1, SK1, A1, K1, and those with two holes are indicated as SA2, SK2, A2, K2.  
 2. Specify the intervals between the attachments when ordering.  
 3. Unless otherwise specified, the attachments are attached to the outer links of even numbers.

## Chain Body

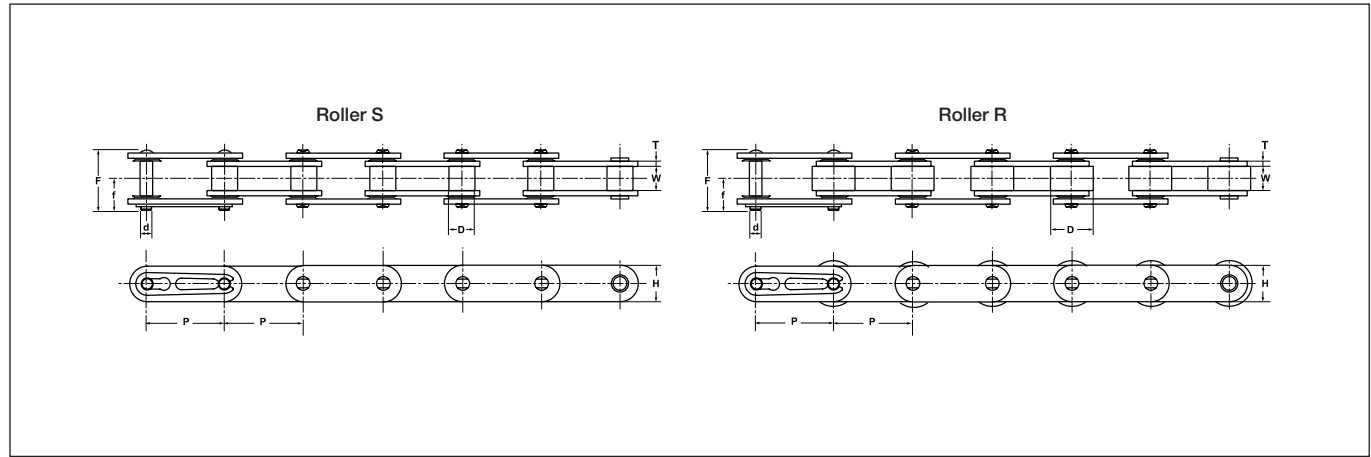

## Attachment

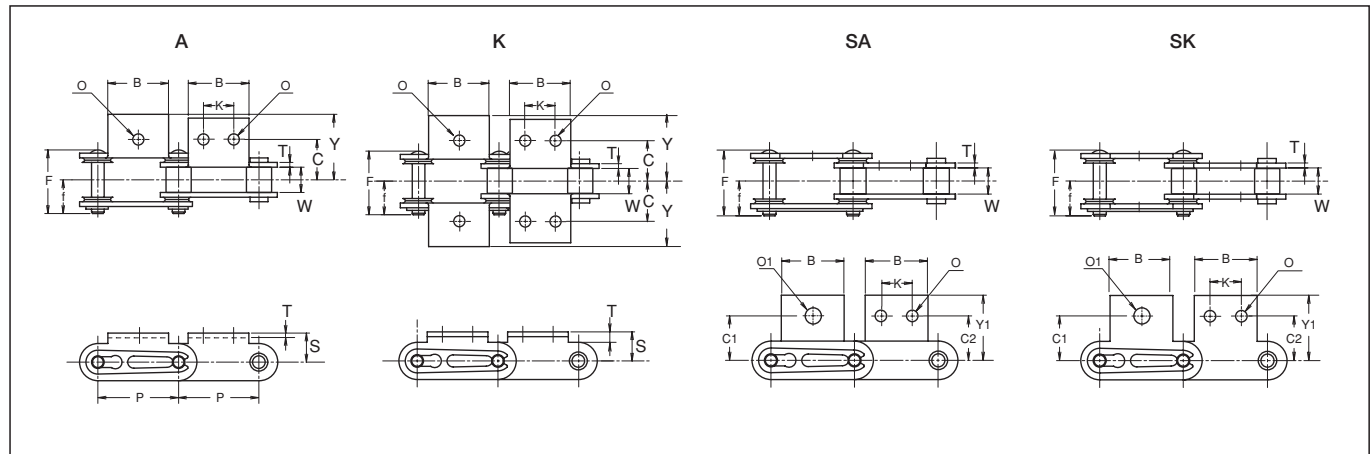



## Dimensions of O-ring Chain (Double pitch)

### • Dimensions of Chain Bodies

Unit (mm)

Chain No.		Pitch <b>P</b>	Roller link width <b>W</b>	Roller (bush) dia. <b>D</b>	Pin			Plate		Avg. tensile strength		Max. allowable load		Approx. weight without attachments (kg/m)
Standard	Rustless				<b>d</b>	<b>F</b>	<b>f</b>	<b>T</b>	<b>H</b>	kN	kgf	kN	kgf	
<b>DIDC2040LX</b>	<b>DIDC2040LXN</b>	25.40	7.95	7.92	3.97	20.0	10.7	1.5	11.7	16.18	1,650	2.64	270	0.52
<b>DIDC2042LX</b>	<b>DIDC2042LXN</b>			15.88										0.89
<b>DIDC2050LX</b>	<b>DIDC2050LXN</b>	31.75	9.53	10.16	5.09	23.9	12.8	2.0	15.1	27.45	2,800	4.41	450	0.87
<b>DIDC2052LX</b>	<b>DIDC2052LXN</b>			19.05										1.35
<b>DIDC2060HLX</b>	<b>DIDC2060HLXN</b>	38.10	12.70	11.91	5.96	33.5	17.9	3.2	17.2	38.24	3,900	6.47	660	1.46
<b>DIDC2062HLX</b>	<b>DIDC2062HLXN</b>			22.23										2.18

Note: The values of the avg. tensile strength and max. allowable load are for the chains (attachments aren't included).

### • Dimensions of attachment

Chain No.		Pitch <b>P</b>	Attachment A, K			Attachment SA, SK				Common dimensions			Approx. additional weight per attachment (kg)	
Standard	Rustless		<b>C</b>	<b>Y</b>	<b>S</b>	<b>Y<sub>1</sub></b>	<b>C<sub>1</sub></b>	<b>C<sub>2</sub></b>	<b>O<sub>1</sub></b>	<b>B</b>	<b>K</b>	<b>O</b>	<b>A,SA</b>	<b>K,SK</b>
<b>DIDC2040LX</b>	<b>DIDC2040LXN</b>	25.40	12.70	20.6	9.13	19.8	11.11	13.50	5.2	19.1	9.53	3.5	0.003	0.006
<b>DIDC2042LX</b>	<b>DIDC2042LXN</b>													
<b>DIDC2050LX</b>	<b>DIDC2050LXN</b>	31.75	15.88	25.6	11.11	24.6	14.29	15.88	6.8	23.8	11.91	5.2	0.006	0.012
<b>DIDC2052LX</b>	<b>DIDC2052LXN</b>													
<b>DIDC2060HLX</b>	<b>DIDC2060HLXN</b>	38.10	21.43	34.7	14.68	30.6	17.46	19.05	8.7	28.6	14.29	5.2	0.016	0.032
<b>DIDC2062HLX</b>	<b>DIDC2062HLXN</b>													

### Chain Body

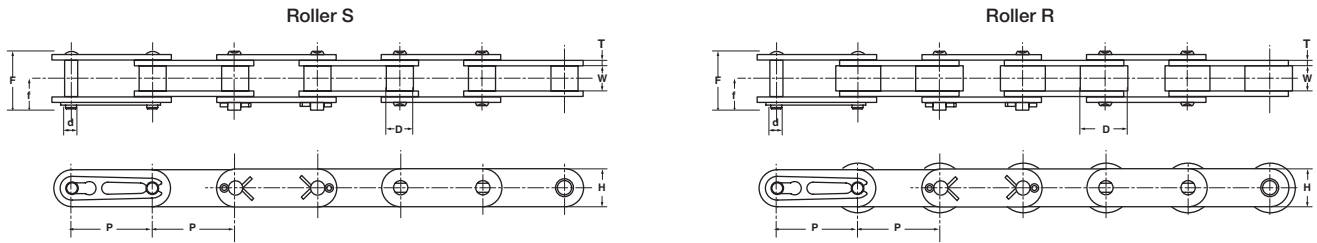

Use R connecting links (RJ) for #2060 or smaller and C connecting links (CJ) for #2080 or larger.

### Attachment

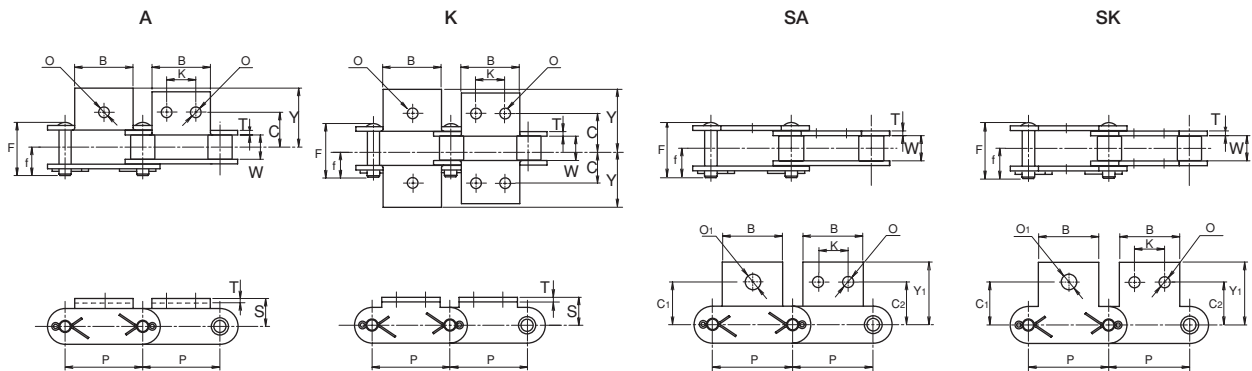

This figure shows C connecting links (CJ) but R connecting links (RJ) are used for #2060 or smaller.



## Dimensions of Sintered Bushing Roller Chain (Double pitch)

### • Dimensions of Chain Bodies

Unit (mm)

Chain No.		Pitch	Roller link width	Roller (bush) dia.	Pin			Plate		Avg. tensile strength		Max. allowable load		Approx. weight without attachments (kg/m)
Standard	Rustless	P	W	D	d	F	f	T	H	kN	kgf	kN	kgf	(kg/m)
<b>DIDC2040UR</b>	<b>DIDC2040URN</b>	25.40	7.95	7.92	3.97	17.6	9.5	1.5	11.7	15.69	1,600	2.64	270	0.49
<b>DIDC2042UR</b>	<b>DIDC2042URN</b>			15.88										0.86
<b>DIDC2050UR</b>	<b>DIDC2050URN</b>	31.75	9.53	10.16	5.09	21.9	11.6	2.0	15.1	25.49	2,600	4.31	440	0.84
<b>DIDC2052UR</b>	<b>DIDC2052URN</b>			19.05										1.32
<b>DIDC2060HUR</b>	<b>DIDC2060HURN</b>	38.10	12.70	11.91	5.96	30.1	17.0	3.2	17.2	37.26	3,800	6.27	640	1.45
<b>DIDC2062HUR</b>	<b>DIDC2062HURN</b>			22.23										2.17
<b>DIDC2080HUR</b>	<b>DIDC2080HURN</b>	50.80	15.88	15.88	7.94	38.7	20.6	4.0	23.3	63.74	6,500	10.68	1,090	2.46
<b>DIDC2082HUR</b>	<b>DIDC2082HURN</b>			25.58										3.53

Roller Chains for Power Transmission

Double Pitch

### • Dimensions of attachment

Chain No.		Pitch	Attachment A, K			Attachment SA, SK				Common dimensions			Approx. additional weight per attachment (kg)	
Standard	Rustless	P	C	Y	S	Y <sub>1</sub>	C <sub>1</sub>	C <sub>2</sub>	O <sub>1</sub>	B	K	O	A,SA	K,SK
<b>DIDC2040UR</b>	<b>DIDC2040URN</b>	25.40	12.70	19.4	9.13	19.8	11.11	13.50	5.2	19.1	9.53	3.5	0.003	0.006
<b>DIDC2042UR</b>	<b>DIDC2042URN</b>													
<b>DIDC2050UR</b>	<b>DIDC2050URN</b>	31.75	15.88	24.4	11.11	24.6	14.29	15.88	6.8	23.8	11.91	5.2	0.006	0.012
<b>DIDC2052UR</b>	<b>DIDC2052URN</b>													
<b>DIDC2060HUR</b>	<b>DIDC2060HURN</b>	38.10	21.43	33.3	14.68	30.6	17.46	19.05	8.7	28.6	14.29	5.2	0.016	0.032
<b>DIDC2062HUR</b>	<b>DIDC2062HURN</b>													
<b>DIDC2080HUR</b>	<b>DIDC2080HURN</b>	50.80	27.78	40.8	19.05	40.5	22.23	25.40	10.3	38.1	19.05	6.8	0.034	0.068
<b>DIDC2082HUR</b>	<b>DIDC2082HURN</b>													

Note: The values of the avg. tensile strength and max. allowable load are for the chains (attachments aren't included).

**Chain Body**

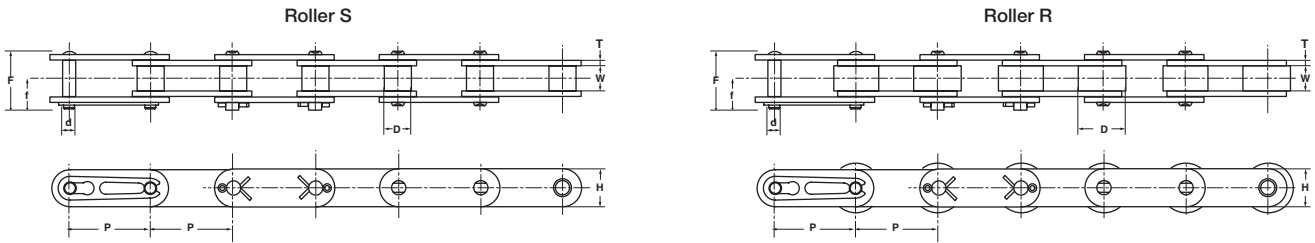

Use R connecting links (RJ) for #2060 or smaller and C connecting links (CJ) for #2080 or larger.

**Attachment**

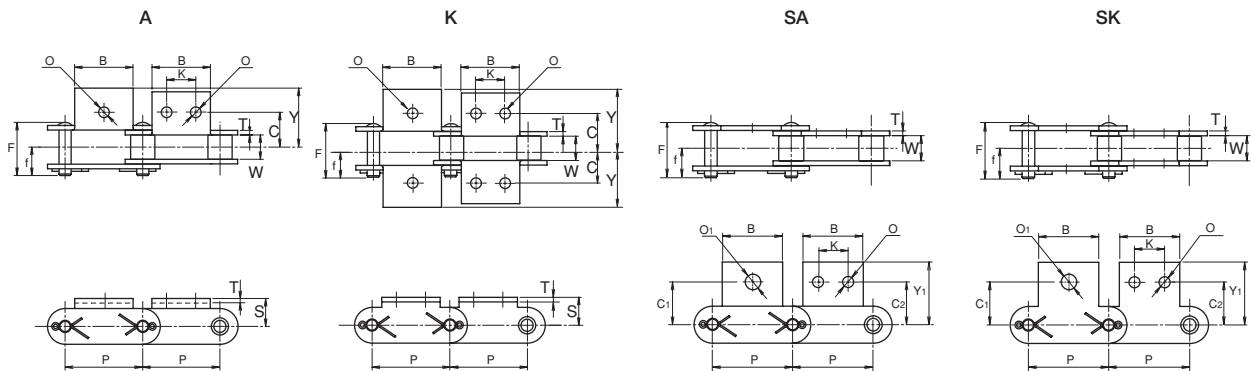

This figure shows C connecting links (CJ) but R connecting links (RJ) are used for #2060 or smaller.





## Dimensions of Rustless Chain (Double pitch)

### • Dimensions of Chain Bodies

Unit (mm)

Chain No.	Pitch <b>P</b>	Roller link width <b>W</b>	Roller (bush) dia. <b>D</b>	Pin			Plate		Avg. tensile strength		Max. allowable load		Approx. weight without attachments (kg/m)
				<b>d</b>	<b>F</b>	<b>f</b>	<b>T</b>	<b>H</b>	kN	kgf	kN	kgf	
<b>DID C2040N</b> <b>DID C2042N</b>	25.40	7.95	7.92 15.88	3.97	17.6	9.5	1.5	11.7	17.0	1,740	2.64	270	0.49 0.86
<b>DID C2050N</b> <b>DID C2052N</b>	31.75	9.53	10.16 19.05	5.09	21.9	11.6	2.0	15.1	28.7	2,930	4.41	450	0.84 1.32
<b>DID C2060HN</b> <b>DID C2062HN</b>	38.10	12.70	11.91 22.23	5.96	30.1	16.1	3.2	17.2	40.2	4,100	6.47	660	1.45 2.17
<b>DID C2080HN</b> <b>DID C2082HN</b>	50.80	15.88	15.88 28.58	7.94	38.7	20.6	4.0	23.3	68.6	7,000	11.2	1,150	2.46 3.53
<b>DID C2100HN</b> <b>DID C2102HN</b>	63.50	19.05	19.05 39.68	9.54	45.8	24.4	4.8	28.8	112	11,500	18.6	1,900	3.60 5.81
<b>DID C2120HN</b> <b>DID C2122HN</b>	76.20	25.40	22.23 44.45	11.11	56.5	29.9	5.6	33.8	156	16,000	25.5	2,600	5.09 8.09
<b>DID C2160HN</b> <b>DID C2162HN</b>	101.60	31.75	28.58 57.15	14.29	71.6	38.2	7.1	47.4	259	26,500	42.1	4,300	8.91 13.60

Note: The values of the avg. tensile strength and max. allowable load are for the chains (attachments aren't included).

### • Dimensions of attachment

Chain No.	Pitch <b>P</b>	Attachment											Approx. additional weight per attachment (kg)	
		<b>S</b>	<b>C</b>	<b>Y</b>	<b>Y<sub>1</sub></b>	<b>C<sub>1</sub></b>	<b>C<sub>2</sub></b>	<b>K</b>	<b>B</b>	<b>O</b>	<b>O<sub>1</sub></b>	<b>T</b>	<b>A,SA</b>	<b>K,SK</b>
<b>DID C2040N</b> <b>DID C2042N</b>	25.40	9.13	12.70	19.4	19.8	11.11	13.50	9.53	19.1	3.5	5.2	1.5	0.003	0.006
<b>DID C2050N</b> <b>DID C2052N</b>	31.75	11.11	15.88	24.4	24.6	14.29	15.88	11.91	23.8	5.2	6.8	2.0	0.006	0.012
<b>DID C2060HN</b> <b>DID C2062HN</b>	38.10	14.68	21.43	33.3	30.6	17.46	19.05	14.29	28.6	5.2	8.7	3.2	0.016	0.032
<b>DID C2080HN</b> <b>DID C2082HN</b>	50.80	19.05	27.78	40.8	40.5	22.23	25.40	19.05	38.1	6.8	10.3	4.0	0.034	0.068
<b>DID C2100HN</b> <b>DID C2102HN</b>	63.50	23.42	33.34	51.6	50.4	28.58	31.75	23.81	47.6	8.7	14.3	4.8	0.064	0.128
<b>DID C2120HN</b> <b>DID C2122HN</b>	76.20	27.78	39.69	62.9	59.9	33.34	37.31	28.58	57.1	10.3	16.0	5.6	0.108	0.216
<b>DID C2160HN</b> <b>DID C2162HN</b>	101.60	36.51	52.39	79.0	78.6	44.45	50.80	38.10	76.2	14.3	22.0	7.1	0.246	0.492

Note: 1. Attachments with one hole are indicated as SA1, SK1, A1, K1, and those with two holes are indicated as SA2, SK2, A2, K2.

2. Specify the intervals between the attachments when ordering.

3. Unless otherwise specified, the attachments are attached to the outer links of even numbers.

**Chain Body**

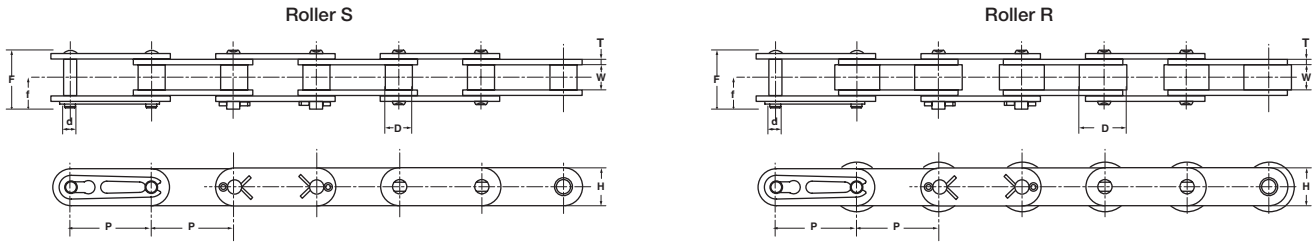

Use R connecting links (RJ) for #2060 or smaller and C connecting links (CJ) for #2080 or larger.

**Attachment**

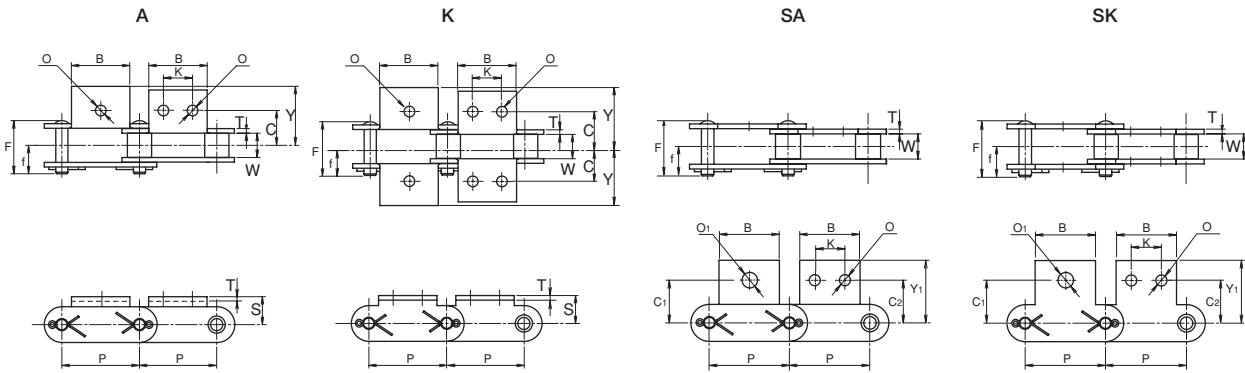

This figure shows C connecting links (CJ) but R connecting links (RJ) are used for #2060 or smaller.



## Dimensions of High Guard Chain (Double pitch)

### • Dimensions of Chain Bodies

Unit (mm)

Chain No.	Pitch <b>P</b>	Roller link width <b>W</b>	Roller (bush) dia. <b>D</b>	Pin			Plate		Avg. tensile strength		Max. allowable load		Approx. weight without attachments (kg/m)
				<b>d</b>	<b>F</b>	<b>f</b>	<b>T</b>	<b>H</b>	kN	kgf	kN	kgf	
<b>DID C2040E</b> <b>DID C2042E</b>	25.40	7.95	7.92 15.88	3.97	17.6	9.5	1.5	11.7	17.0	1,740	2.64	270	0.49 0.86
<b>DID C2050E</b> <b>DID C2052E</b>	31.75	9.53	10.16 19.05	5.09	21.9	11.6	2.0	15.1	28.7	2,930	4.41	450	0.84 1.32
<b>DID C2060HE</b> <b>DID C2062HE</b>	38.10	12.70	11.91 22.23	5.96	30.1	16.1	3.2	17.2	40.2	4,100	6.47	660	1.45 2.17
<b>DID C2080HE</b> <b>DID C2082HE</b>	50.80	15.88	15.88 28.58	7.94	38.7	20.6	4.0	23.3	68.6	7,000	11.2	1,150	2.46 3.53
<b>DID C2100HE</b> <b>DID C2102HE</b>	63.50	19.05	19.05 39.68	9.54	45.8	24.4	4.8	28.8	112	11,500	18.6	1,900	3.60 5.81
<b>DID C2120HE</b> <b>DID C2122HE</b>	76.20	25.40	22.23 44.45	11.11	56.5	29.9	5.6	33.8	156	16,000	25.5	2,600	5.09 8.09
<b>DID C2160HE</b> <b>DID C2162HE</b>	101.60	31.75	28.58 57.15	14.29	71.6	38.2	7.1	47.4	259	26,500	42.1	4,300	8.91 13.60

Note: The values of the avg. tensile strength and max. allowable load are for the chains (attachments aren't included).

### • Dimensions of attachment

Chain No.	Pitch <b>P</b>	Attachment											Approx. additional weight per attachment (kg)	
		<b>S</b>	<b>C</b>	<b>Y</b>	<b>Y<sub>1</sub></b>	<b>C<sub>1</sub></b>	<b>C<sub>2</sub></b>	<b>K</b>	<b>B</b>	<b>O</b>	<b>O<sub>1</sub></b>	<b>T</b>	<b>A,SA</b>	<b>K,SK</b>
<b>DID C2040E</b> <b>DID C2042E</b>	25.40	9.13	12.70	19.4	19.8	11.11	13.50	9.53	19.1	3.5	5.2	1.5	0.003	0.006
<b>DID C2050E</b> <b>DID C2052E</b>	31.75	11.11	15.88	24.4	24.6	14.29	15.88	11.91	23.8	5.2	6.8	2.0	0.006	0.012
<b>DID C2060HE</b> <b>DID C2062HE</b>	38.10	14.68	21.43	33.3	30.6	17.46	19.05	14.29	28.6	5.2	8.7	3.2	0.016	0.032
<b>DID C2080HE</b> <b>DID C2082HE</b>	50.80	19.05	27.78	40.8	40.5	22.23	25.40	19.05	38.1	6.8	10.3	4.0	0.034	0.068
<b>DID C2100HE</b> <b>DID C2102HE</b>	63.50	23.42	33.34	51.6	50.4	28.58	31.75	23.81	47.6	8.7	14.3	4.8	0.064	0.128
<b>DID C2120HE</b> <b>DID C2122HE</b>	76.20	27.78	39.69	62.9	59.9	33.34	37.31	28.58	57.1	10.3	16.0	5.6	0.108	0.216
<b>DID C2160HE</b> <b>DID C2162HE</b>	101.60	36.51	52.39	79.0	78.6	44.45	50.80	38.10	76.2	14.3	22.0	7.1	0.246	0.492

Note: 1. Attachments with one hole are indicated as SA1, SK1, A1, K1, and those with two holes are indicated as SA2, SK2, A2, K2.

2. Specify the intervals between the attachments when ordering.

3. Unless otherwise specified, the attachments are attached to the outer links of even numbers.

## Chain Body

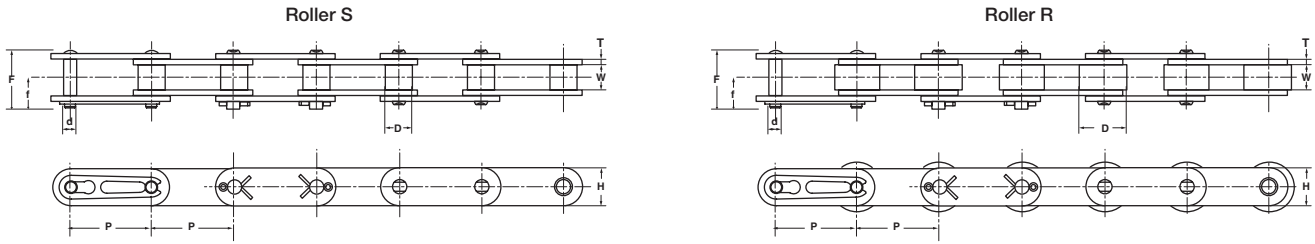

Use R connecting links (RJ) for #2060 or smaller and C connecting links (CJ) for #2080 or larger.

## Attachment

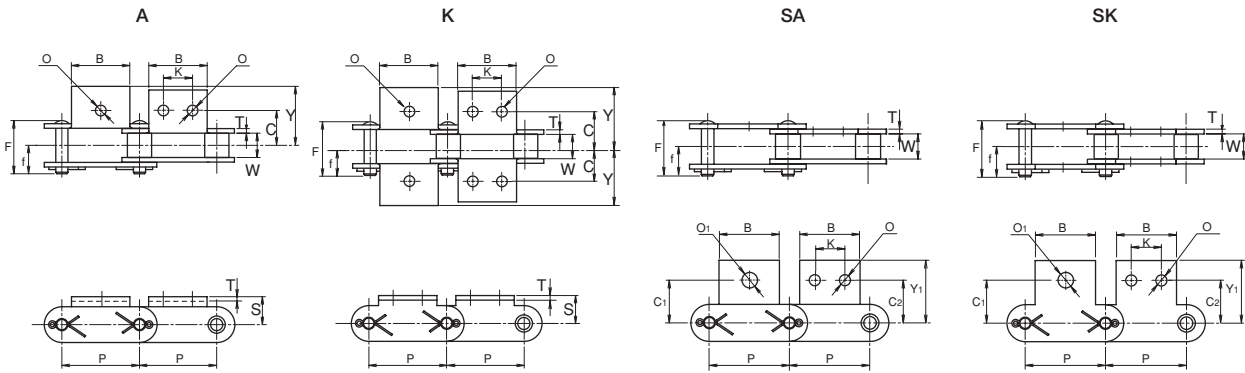

This figure shows C connecting links (CJ) but R connecting links (RJ) are used for #2060 or smaller.



## Dimensions of Double Guard Chain (Double pitch)

### • Dimensions of Chain Bodies

Unit (mm)

Chain No.	Pitch <b>P</b>	Roller link width <b>W</b>	Roller (bush) dia. <b>D</b>	Pin			Plate		Avg. tensile strength		Max. allowable load		Approx. weight without attachments (kg/m)
				<b>d</b>	<b>F</b>	<b>f</b>	<b>T</b>	<b>H</b>	kN	kgf	kN	kgf	
<b>DID C2040WG</b> <b>DID C2042WG</b>	25.40	7.95	7.92 15.88	3.97	17.6	9.5	1.5	11.7	17.0	1,740	2.64	270	0.49 0.86
<b>DID C2050WG</b> <b>DID C2052WG</b>	31.75	9.53	10.16 19.05	5.09	21.9	11.6	2.0	15.1	28.7	2,930	4.41	450	0.84 1.32
<b>DID C2060HWG</b> <b>DID C2062HWG</b>	38.10	12.70	11.91 22.23	5.96	30.1	16.1	3.2	17.2	40.2	4,100	6.47	660	1.45 2.17
<b>DID C2080HWG</b> <b>DID C2082HWG</b>	50.80	15.88	15.88 28.58	7.94	38.7	20.6	4.0	23.3	68.6	7,000	11.2	1,150	2.46 3.53

Note: 1. The values of the Avg. tensile strength and max. allowable load are for the chains (attachments aren't included).  
2. Consult us for the sizes other than the above.

### • Dimensions of attachment

Chain No.	Pitch <b>P</b>	Attachment A, K			Attachment SA, SK				Common dimensions			Approx. additional weight per attachment (kg)	
		<b>C</b>	<b>Y</b>	<b>S</b>	<b>Y<sub>1</sub></b>	<b>C<sub>1</sub></b>	<b>C<sub>2</sub></b>	<b>O<sub>1</sub></b>	<b>B</b>	<b>K</b>	<b>O</b>	<b>A,SA</b>	<b>K,SK</b>
<b>DID C2040WG</b> <b>DID C2042WG</b>	25.40	12.70	19.4	9.13	19.8	11.11	13.50	5.2	19.1	9.53	3.5	0.003	0.006
<b>DID C2050WG</b> <b>DID C2052WG</b>	31.75	15.88	24.4	11.11	24.6	14.29	15.88	6.8	23.8	11.91	5.2	0.006	0.012
<b>DID C2060HWG</b> <b>DID C2062HWG</b>	38.10	21.43	33.3	14.68	30.6	17.46	19.05	8.7	28.6	14.29	5.2	0.016	0.032
<b>DID C2080HWG</b> <b>DID C2082HWG</b>	50.80	27.78	40.8	19.05	40.5	22.23	25.40	10.3	38.1	19.05	6.8	0.034	0.068

Note: 1. Attachments with one hole are indicated as SA1, SK1, A1, K1, and those with two holes are indicated as SA2, SK2, A2, K2.  
2. Specify the intervals between the attachments when ordering.  
3. Unless otherwise specified, the attachments are attached to the outer links of even numbers.

## Chain Body

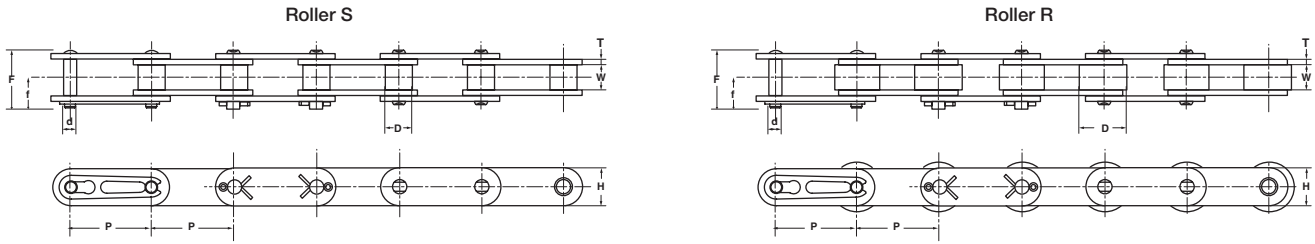

Use R connecting links (RJ) for #2060 or smaller and C connecting links (CJ) for #2080 or larger.

## Attachment

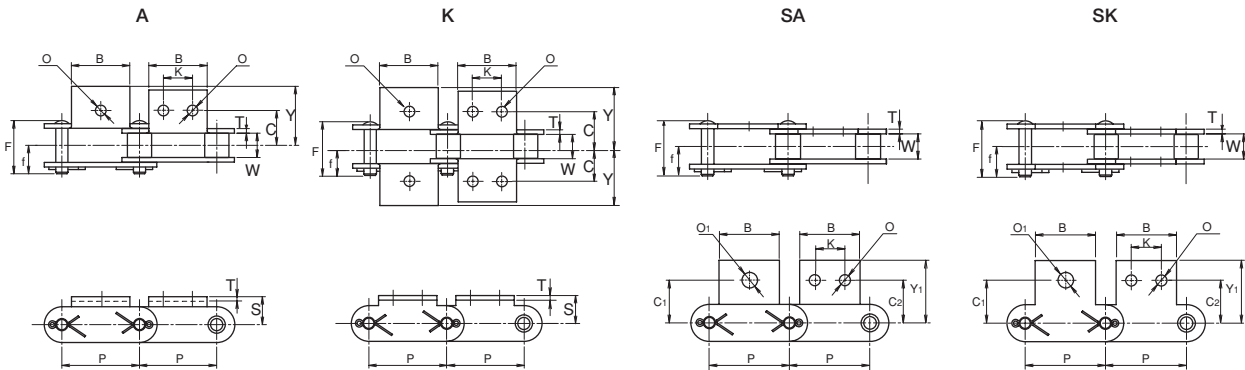

This figure shows C connecting links (CJ) but R connecting links (RJ) are used for #2060 or smaller.



## Dimensions of Stainless Steel Chain (Double pitch)

### • Dimensions of Chain Bodies

Unit (mm)

Chain No.	Pitch <b>P</b>	Roller link width <b>W</b>	Roller (bush) dia. <b>D</b>	Pin			Plate		Avg. tensile strength		Max. allowable load		Approx. weight without attachments (kg/m)
				<b>d</b>	<b>F</b>	<b>f</b>	<b>T</b>	<b>H</b>	SS		SSK		
									kN	kgf	kN	kgf	
DID C2040SS,SSK DID C2042SS,SSK	25.40	7.85	7.95 15.88	3.96	17.7	9.55	1.5	11.7	0.44	45	0.69	70	0.50 0.82
DID C2050SS,SSK DID C2052SS,SSK	31.75	9.40	10.16 19.05	5.08	22.0	11.75	2.0	14.9	0.69	70	1.03	105	0.84 1.27
DID C2060HSS,SSK DID C2062HSS,SSK	38.10	12.57	11.91 22.23	5.95	31.5	16.85	3.2	17.0	1.03	105	1.57	160	1.44 2.14
DID C2080HSS,SSK DID C2082HSS,SSK	50.80	15.75	15.88 28.58	7.93	38.0	20.10	4.0	23.0	1.77	180	2.65	270	2.47 3.59
DID C2100HSS,SSK DID C2102HSS,SSK	63.50	18.90	19.05 39.68	9.53	45.6	23.85	4.8	28.8	2.55	260	3.82	390	3.79 6.15

Note: The values of the avg. tensile strength and max. allowable load are for the chains (attachments aren't included).

### • Dimensions of attachment

Chain No.	Pitch <b>P</b>	Attachment A, K			Attachment SA, SK				Common dimensions			Approx. additional weight per attachment (kg)	
		<b>Y</b>	<b>S</b>	<b>C</b>	<b>Y<sub>1</sub></b>	<b>C<sub>1</sub></b>	<b>C<sub>2</sub></b>	<b>O<sub>1</sub></b>	<b>B</b>	<b>K</b>	<b>O</b>	<b>A,SA</b>	<b>K,SK</b>
DID C2040SS,SSK DID C2042SS,SSK	25.40	19.0	9.1	12.70	19.8	11.1	13.5	5.2	19.3	9.53	3.6	0.003	0.006
DID C2050SS,SSK DID C2052SS,SSK	31.75	24.1	11.1	15.88	24.6	14.3	15.9	6.8	24.0	11.91	5.2	0.006	0.012
DID C2060HSS,SSK DID C2062HSS,SSK	38.10	31.4	14.7	21.43	30.6	17.5	19.1	8.7	28.8	14.30	5.2	0.017	0.034
DID C2080HSS,SSK DID C2082HSS,SSK	50.80	41.7	19.1	27.78	41.4	22.2	25.4	10.3	38.1	19.05	6.8	0.037	0.074
DID C2100HSS,SSK DID C2102HSS,SSK	63.50	52.2	23.8	33.34	53.4	28.6	31.8	14.3	47.6	23.81	8.7	0.067	0.134

1. Attachments with one hole are indicated as SA1, SK1, A1, K1, and those with two holes are indicated as SA2, SK2, A2, K2.
2. Specify the intervals between the attachments when ordering.
3. Unless otherwise specified, the attachments are attached to the outer links of even numbers.

**Chain Body**

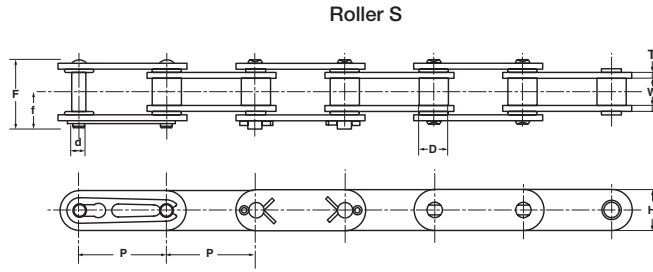

Use R connecting links (RJ) for #2060 or smaller and C connecting links (CJ) for #2080.

**Attachment**

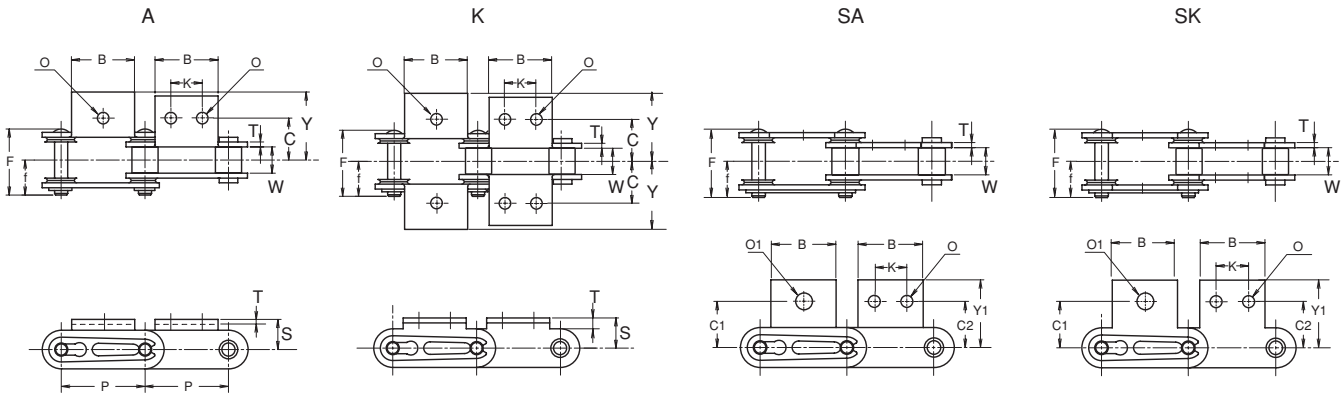

This figure shows R connecting links (RJ) but C connecting links (CJ) are used for #2080.

Small Conveyor Chains

Double Pitch



## Dimensions of Stainless Steel X-Ring Chain (Double pitch)

### • Dimensions of Chain Bodies

Unit (mm)

Chain No.	Pitch <b>P</b>	Roller link width <b>W</b>	Roller (bush) dia. <b>D</b>	Pin			Plate		Avg. tensile strength		Max. allowable load		Approx. weight without attachments (kg/m)
				<b>d</b>	<b>F</b>	<b>f</b>	<b>T</b>	<b>H</b>	kN	kgf	kN	kgf	
<b>DID C2040SSLT</b>	25.40	7.95	7.92	3.96	20.0	10.7	1.5	11.7	13.3	1,360	0.4	45	0.50
<b>DID C2050SSLT</b>	31.75	9.53	10.16	5.08	23.9	12.8	2.0	14.9	20.8	2,130	0.6	70	0.86
<b>DID C2060HSSLT</b>	38.10	12.70	11.91	5.95	33.0	17.6	3.2	17.0	31.0	3,170	1.0	110	1.48
<b>DID C2080HSSLT</b>	50.80	15.88	15.88	7.93	41.8	22.5	4.0	23.0	55.8	5,700	1.7	180	2.49



Note: The values of the avg. tensile strength and max. allowable load are for the chains (attachments aren't included).

### • Dimensions of attachment

Chain No.	Pitch <b>P</b>	Attachment										
		<b>S</b>	<b>C</b>	<b>Y</b>	<b>Y<sub>1</sub></b>	<b>C<sub>1</sub></b>	<b>C<sub>2</sub></b>	<b>K</b>	<b>B</b>	<b>O</b>	<b>O<sub>1</sub></b>	<b>T</b>
<b>DID C2040SSLT</b>	25.40	9.1	12.70	20.2	19.8	11.1	13.5	9.53	19.3	3.6	5.2	1.5
<b>DID C2050SSLT</b>	31.75	11.1	15.88	25.2	24.6	14.3	15.9	11.91	24.0	5.2	6.8	2.0
<b>DID C2060HSSLT</b>	38.10	14.7	21.43	32.8	30.6	17.5	19.1	14.30	28.8	5.2	8.7	3.2
<b>DID C2080HSSLT</b>	50.80	19.1	27.78	43.4	41.4	22.2	25.4	19.05	38.1	6.8	10.3	4.0

Note: 1. Attachments with one hole are indicated as SA1, SK1, A1, K1, and those with two holes are indicated as SA2, SK2, A2, K2.  
 2. Specify the intervals between the attachments when ordering.  
 3. Unless otherwise specified, the attachments are attached to the outer links of even numbers.



## Free Flow Chains and Other Conveyor Chains

	Free Flow Chains		Other Conveyor Chains
	Top Roller Chain	Side Roller Chain	Hollow Pin Chain (HP)
Name			
Features	Loads can be directly placed on the top rollers. By attaching a stopper on the conveyor, loads can be temporarily stopped or stored while continuously driving the chain.	This chain is used for a free flow conveyor that runs on rails, and the side rollers carry the weight of loads. Compared with Top Roller Chain of the same material, it can carry heavier load.	The chain is connected with hollow pins that can be used for fitting various attachments.

### ■ DID Free Flow Chains and Other Conveyor Chains

	Top Roller Chain				Side Roller Chain			Hollow Pin Chain (HP)	Flexible Chain (FX)	Flat Plate Type Chain (F)
	Simplex		Duplex		Meandering prevention (SG)	With breaks (SRB)				
	Every two links (2P-TR)	Every link (1P-TR)	Overturn prevention (TG)	With breaks (TRB)			Every two links (2P-TR内)			
<b>DID 35</b>	—	—	—	—	—	—	—	—	—	○
<b>DID 40</b>	I※2	S※3	IO※2	○	OI※2	S※3	○※1	—	○※1	○
<b>DID 50</b>	I	S	IO	—	OI	S	○	—	○	○
<b>DID 60</b>	I	S	IO	—	OI	S	○	—	○	○
<b>DID 80</b>	I	S	IO	—	OI	S	—	—	○	○
<b>DID 100</b>	I	S	IO	—	OI	S	—	—	○	○
<b>DID 120</b>	—	—	—	—	—	—	—	—	—	○
<b>DID C2040</b>	OI	○	I	—	OI	○	○	—	○	○
<b>DID C2050</b>	OI	○	I	—	OI	○	○	—	○	○
<b>DID C2060H</b>	OI	○	I	—	OI	○	○	—	○	○
<b>DID C2080H</b>	OI	○	I	—	OI	○	○	—	○	○
<b>DID C2100H</b>	OI	○	I	—	OI	○	○	—	○	○
<b>DID C2042</b>	OI	○	I	—	OI	○	—	L※3	○	○
<b>DID C2052</b>	OI	○	I	—	OI	○	—	L	○	○
<b>DID C2062H</b>	OI	○	I	—	OI	○	—	L	○	○
<b>DID C2082H</b>	OI	○	I	—	OI	○	—	L	○	○
<b>DID C2102H</b>	OI	○	I	—	OI	○	—	L	○	○

- Note: ※ 1. Standard chains are available for those indicated with ○.  
 ※ 2. I: Top rollers are attached to inner links.  
 O: Top rollers are attached to outer links.  
 IO: Top rollers are attached to the inner links unless specified.  
 OI: Top rollers are attached to the outer links unless specified.  
 ※ 3. S: Top roller diameter is smaller compared with other chains of the same sizes.  
 L: Top roller diameter is larger compared with other chains of the same sizes.

Other Conveyor Chains		Others	
	Flexible Chain (FX)	Flat Plate Type Roller Chain (F)	Push Chain (PU)
			
	This chain has much sideward bending flexibility and is suitable for curved traveling.	Damage to chain guards and other parts are reduced with the use of oval-shaped flat plates, and loads can be set directly on the chain.	This is the first chain that has the ability to push. New layouts are possible since loads can be pushed and pulled without using the guide, and space can be saved compared to the use of cylinders.

Name

Features

Roller Chains for Power Transmission

Others

# Small Conveyor Chains Single Pitch Top Roller Chain

## ● Every-link Top Roller Chain

[Type indication]

**DID 50 1P-TR-J**



(The diameter of top rollers is smaller than that of every-two-link top rollers)

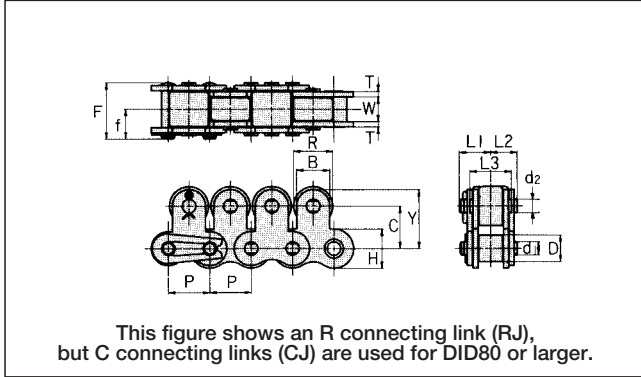

## ● Every-two-link Top Roller Chain

[Type indication]

**DID 50 2P-TR-F**



(A chain with top rollers attached to outer links is not available as standard.)

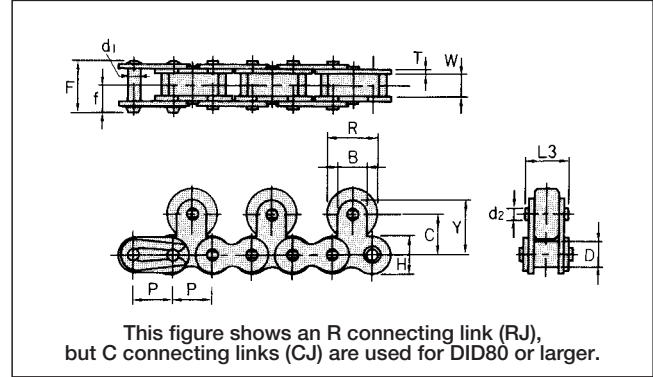

## Dimensions of chain body

Unit (mm)

Chain No.	Pitch <b>P</b>	Roller link width <b>W</b>	Roller (bush) dia. <b>D</b>	Pin			Plate		Avg. tensile strength		Max. allowable load	
				$d_1$	<b>F</b>	<b>f</b>	<b>T</b>	<b>H</b>	kN	kgf	kN	kgf
<b>DID 40 TR</b>	12.70	7.95	7.92	3.97	17.6	9.5	1.5	12.0	18.6	1,900	2.64	270
<b>DID 50 TR</b>	15.875	9.53	10.16	5.09	21.9	11.6	2.0	15.0	28.4	2,900	4.41	450
<b>DID 60 TR</b>	19.05	12.00	11.91	5.96	26.9	14.3	2.4	18.1	44.1	4,500	6.37	650
<b>DID 80 TR</b>	25.40	15.88	15.88	7.94	35.4	19.0	3.2	24.0	78.4	8,000	10.7	1,100
<b>DID100 TR</b>	31.75	19.05	19.05	9.54	42.5	22.7	4.0	29.9	118	12,100	17.1	1,750

## Dimensions of top roller

Chain No.	Every-2-link top roller							Every-link top roller										
	<b>R</b>	<b>C</b>	<b>Y</b>	<b>B</b>	$d_2$	$L_3$	Approx. weight (kg/m)		<b>R</b>	<b>C</b>	<b>Y</b>	<b>B</b>	$d_2$	$L_1$	$L_2$	$L_3$	Approx. weight (kg/m)	
							Iron	Resin									Iron	Resin
<b>DID 40 2P-TR</b>	15.88	12.7	17.45	9.5	3.97	13.2	1.21	0.85	11.0	12.7	17.45	9.5	3.97	10.1	8.0	13.2	1.90	1.04
<b>DID 50 2P-TR</b>	19.05	16.2	22.55	12.7	5.24	16.2	1.86	1.41	15.0	16.2	22.55	12.7	5.24	12.1	10.0	16.2	2.49	1.77
<b>DID 60 2P-TR</b>	22.23	18.3	26.25	15.9	5.96	20.4	2.82	2.07	18.0	18.3	26.25	15.9	5.96	15.1	12.8	20.4	3.81	2.60
<b>DID 80 2P-TR</b>	28.58	24.6	34.15	19.1	7.94	26.1	4.79	3.62	24.0	24.6	34.15	19.1	7.94	19.0	16.4	25.7	6.62	4.68
<b>DID100 2P-TR</b>	39.69	31.8	44.5	25.4	9.54	31.0	7.63	5.43	30.0	31.8	44.50	25.4	9.54	22.8	19.7	31.0	9.76	6.82

Note: 1. Approx. weight indicates the value for every-two-link top roller chains.(for inner link)  
2. The material of resin top roller is polyacetal.

## Top roller chain series (Single pitch)

Standard	Long life	Rustless	Double guard	O-ring	O-ring (Rustless)	Sintered	Sintered (Rustless)
<b>DID 40 TR</b>	<b>DID 40D TR</b>	<b>DID 40N TR</b>	<b>DID 40WG TR</b>	<b>DID 40LX TR</b>	<b>DID 40LXN TR</b>	<b>DID C40UR TR</b>	<b>DID C40URN TR</b>
<b>DID 50 TR</b>	<b>DID 50D TR</b>	<b>DID 50N TR</b>	<b>DID 50WG TR</b>	<b>DID 50LX TR</b>	<b>DID 50LXN TR</b>	<b>DID C50UR TR</b>	<b>DID C50URN TR</b>
<b>DID 60 TR</b>	<b>DID 60D TR</b>	<b>DID 60N TR</b>	<b>DID 60WG TR</b>	<b>DID 60LX TR</b>	<b>DID 60LXN TR</b>	<b>DID C60UR TR</b>	<b>DID C60URN TR</b>
<b>DID 80 TR</b>	<b>DID 80D TR</b>	<b>DID 80N TR</b>	<b>DID 80WG TR</b>	<b>DID 80LD TR</b>	<b>DID 80LDN TR</b>	<b>DID C80UR TR</b>	<b>DID C80URN TR</b>
<b>DID100 TR</b>	<b>DID100D TR</b>	<b>DID100N TR</b>	<b>DID100WG TR</b>	<b>DID100LD TR</b>	<b>DID100LDN TR</b>		



• Duplex Every-two-link Top Roller Chain

[Type indication]

**DID 40-2 2P-TR-F**

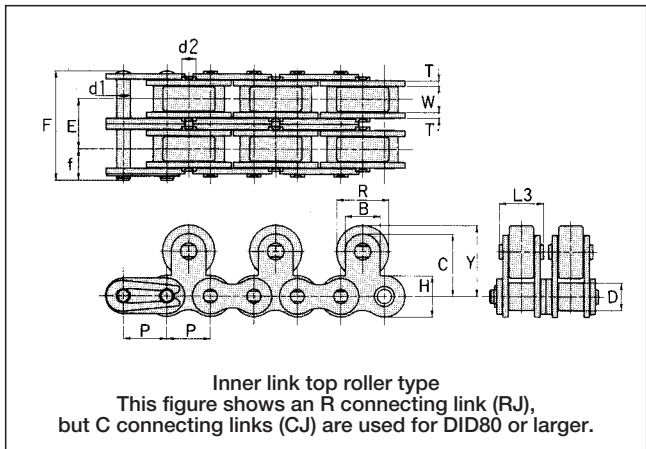
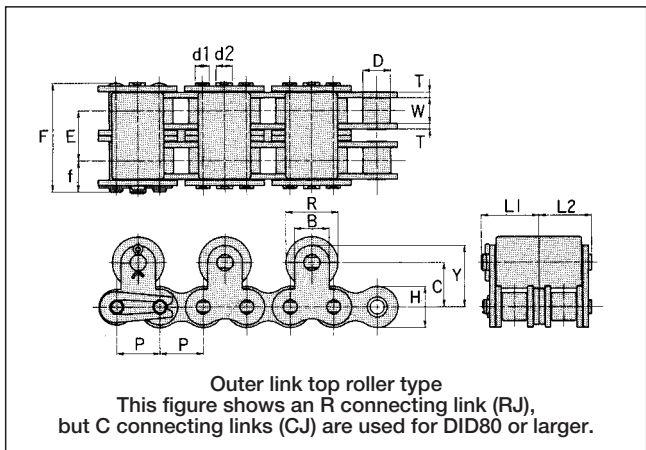
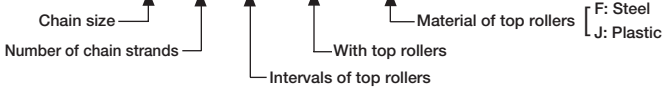

1. Standard inner link top roller type uses two separate rollers as illustrated, but a single roller type is also available.
2. Duplex every-link top roller type is also available. In this case, dimension R changes. See the section of Every-link Top Roller Chain (P198)
3. The connecting links for DID80-2 ~ DID100-2 are cotter types (C connecting links). The dimensions of pins are the same as those shown in the table of dimensions.

Roller Chains for Power Transmission  
Others

Dimensions of chain body

Unit (mm)

Chain No.	Pitch <b>P</b>	Roller link width <b>W</b>	Roller (bush) dia. <b>D</b>	Transverse pitch <b>E</b>	Pin			Plate	
					<b>d<sub>1</sub></b>	<b>F</b>	<b>f</b>	<b>T</b>	<b>H</b>
<b>DID 40-2 2P-TR-F</b>	12.70	7.95	7.92	14.4	3.97	32.1	9.5	1.5	12.0
<b>DID 50-2 2P-TR-F</b>	15.875	9.53	10.16	18.1	5.09	40.1	11.6	2.0	15.0
<b>DID 60-2 2P-TR-F</b>	19.05	12.7	11.91	22.8	5.96	49.8	14.3	2.4	18.1
<b>DID 80-2 2P-TR-F</b>	25.40	15.88	15.88	29.3	7.94	64.7	19.0	3.2	24.1
<b>DID100-2 2P-TR-F</b>	31.75	19.05	19.05	35.8	9.54	78.7	22.8	4.0	29.9

Dimensions of top roller

Chain No.	<b>R</b>	<b>C</b>	<b>Y</b>	<b>B</b>	<b>d<sub>2</sub></b>	<b>L<sub>1</sub></b>	<b>L<sub>2</sub></b>	<b>L<sub>3</sub></b>
<b>DID 40-2 2P-TR-F</b>	15.88	12.7	17.45	9.5	3.97	17.1	15.5	13.2
<b>DID 50-2 2P-TR-F</b>	19.05	16.2	22.55	12.7	5.24	21.0	19.3	16.2
<b>DID 60-2 2P-TR-F</b>	22.23	18.3	26.25	15.9	5.96	26.6	24.2	20.4
<b>DID 80-2 2P-TR-F</b>	28.58	24.6	34.15	19.1	7.94	33.6	31.1	26.1
<b>DID100-2 2P-TR-F</b>	39.69	31.8	44.5	25.4	9.54	40.6	37.7	31.0

Note: Ask us for the delivery time

## ● Simplex Every-link Top Roller Chain

[Type indication]

**DID C2050 1P-TR-F**

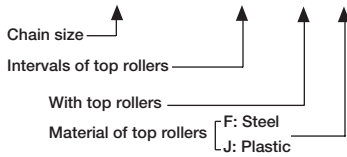

## ● Duplex Every-link Top Roller Chain

[Type indication]

**DID C2060H-2 1P-TR-F**

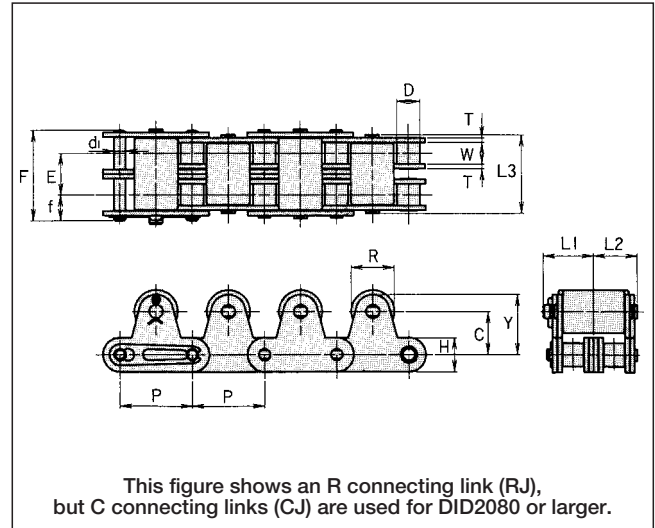
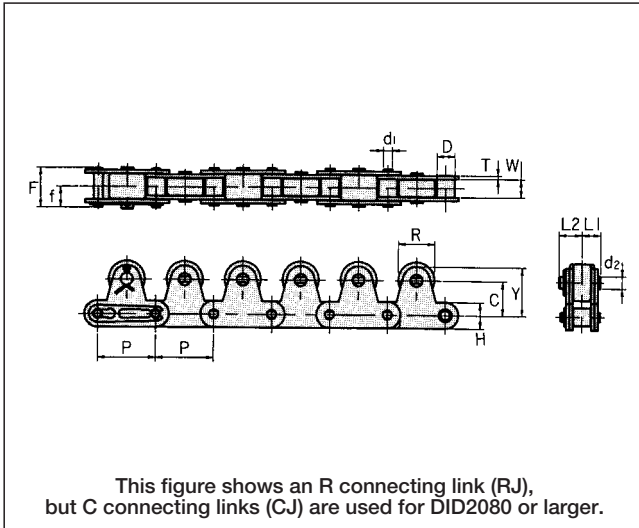
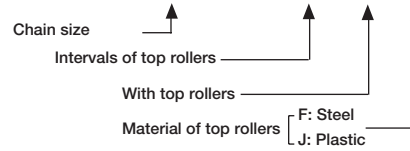

1. The connecting links for DIDC2080H-2 ~ C2100H-2 are cotter types. Even so, the dimensions of pins are the same as those shown in the table of dimensions.
2. In the case of DIDC2060H-2 or larger, dimension E (transverse pitch) is different from that of the standard sprocket. Refer to the tooth profile for HK type duplex chains (P116).
3. When attached to even-numbered links, the top rollers are attached to inner links unless specified otherwise.

## Dimensions of chain body

Unit (mm)

Chain No.	Pitch <b>P</b>	Roller link width <b>W</b>	Roller (bush) dia. <b>D</b>	Pin			Plate		Duplex transverse pitch <b>E</b>	Strength of simplex				Strength of duplex			
				<b>d<sub>1</sub></b>	<b>F</b>	<b>f</b>	<b>T</b>	<b>H</b>		Avg. tensile strength		Max. allowable load		Avg. tensile strength		Max. allowable load	
										kN	kgf	kN	kgf	kN	kgf	kN	kgf
<b>DID C2040 TR</b> <b>DID C2042 TR</b>	25.40	7.95	7.92 15.88	3.97	17.6	9.5	1.5	11.7	14.4	17.0	1,740	2.64	270	34.0	3,480	4.49	460
<b>DID C2050 TR</b> <b>DID C2052 TR</b>	31.75	9.53	10.16 19.05	5.09	21.9	11.6	2.0	15.1	18.1	28.7	2,930	4.41	450	57.4	5,860	7.49	760
<b>DID C2060H TR</b> <b>DID C2062H TR</b>	38.10	12.70	11.91 22.23	5.96	30.1	16.1	3.2	17.2	26.2	40.2	4,100	6.47	660	80.4	8,200	11.0	1,120
<b>DID C2080H TR</b> <b>DID C2082H TR</b>	50.80	15.88	15.88 28.58	7.94	38.7	20.6	4.0	23.3	32.6	68.6	7,000	11.2	1,150	137	14,000	19.0	1,950
<b>DID C2100H TR</b> <b>DID C2102H TR</b>	63.50	19.05	19.05 36.68	9.54	45.8	24.4	4.8	28.8	39.1	112	11,500	18.6	1,900	224	23,000	31.6	3,230

## Dimensions of top roller

Chain No.	Simplex									Duplex								
	Dimensions						Approx. weight (kg/m)			Dimensions						Approx. weight (kg/m)		
	<b>R</b>	<b>C</b>	<b>Y</b>	<b>L<sub>1</sub></b>	<b>L<sub>2</sub></b>	<b>d<sub>2</sub></b>	Iron	Plastic	<b>R</b>	<b>C</b>	<b>Y</b>	<b>d<sub>2</sub></b>	<b>L<sub>1</sub></b>	<b>L<sub>2</sub></b>	<b>L<sub>3</sub></b>	Iron	Plastic	
<b>DID C2040 TR</b> <b>DID C2042 TR</b>	15.88	15.0	21.0	8.45	10.1	5.24	1.31 1.68	0.89 1.26	15.88	15.0	21.0	5.24	17.1	15.5	28.0	2.48 3.12	1.64 2.34	
<b>DID C2050 TR</b> <b>DID C2052 TR</b>	19.05	19.0	26.5	10.50	12.9	5.96	2.04 2.52	1.44 1.92	19.05	19.0	26.5	5.96	22.0	19.6	34.4	3.87 4.78	2.73 3.64	
<b>DID C2060H TR</b> <b>DID C2062H TR</b>	22.23	23.0	31.6	14.75	17.4	7.94	3.62 4.34	2.71 3.44	22.23	23.0	31.6	7.94	30.5	27.9	49.0	6.87 8.24	5.14 6.53	
<b>DID C2080H TR</b> <b>DID C2082H TR</b>	28.58	29.0	39.3	17.80	20.6	9.54	5.58 6.69	4.22 5.33	28.58	29.0	39.3	9.54	36.9	34.5	60.5	10.60 12.71	8.01 10.12	
<b>DID C2100H TR</b> <b>DID C2102H TR</b>	39.69	35.4	48.7	22.10	26.6	14.29	9.02 11.28	6.42 8.68	39.69	35.4	49.7	14.29	46.2	41.7	73.0	17.13 21.43	12.19 16.49	

Note: 1. Approx. weight is of the chain with every 2 pitch top roller (for inner link).  
2. The plastic top roller is made of polyacetal.

## Chain No. - Top Roller Chain series (Double pitch)

Standard	Long life	Rustless	Double guard	O-ring	O-ring (rustless)	Sintered	Sintered (rustless)
<b>DID C2040 TR</b>	<b>DID C2040D TR</b>	<b>DID C2040N TR</b>	<b>DID C2040WG TR</b>	<b>DID C2040LX TR</b>	<b>DID C2040LXN TR</b>	<b>DID C2040UR TR</b>	<b>DID C2040URN TR</b>
<b>DID C2042 TR</b>	<b>DID C2042D TR</b>	<b>DID C2042N TR</b>	<b>DID C2042WG TR</b>	<b>DID C2042LX TR</b>	<b>DID C2042LXN TR</b>	<b>DID C2042UR TR</b>	<b>DID C2042URN TR</b>
<b>DID C2050 TR</b>	<b>DID C2050D TR</b>	<b>DID C2050N TR</b>	<b>DID C2050WG TR</b>	<b>DID C2050LX TR</b>	<b>DID C2050LXN TR</b>	<b>DID C2050UR TR</b>	<b>DID C2050URN TR</b>
<b>DID C2052 TR</b>	<b>DID C2052D TR</b>	<b>DID C2052N TR</b>	<b>DID C2052WG TR</b>	<b>DID C2052LX TR</b>	<b>DID C2052LXN TR</b>	<b>DID C2052UR TR</b>	<b>DID C2052URN TR</b>
<b>DID C2060H TR</b>	<b>DID C2060HD TR</b>	<b>DID C2060HN TR</b>	<b>DID C2060HWG TR</b>	<b>DID C2060HLX TR</b>	<b>DID C2060HLXN TR</b>	<b>DID C2060HUR TR</b>	<b>DID C2060HURN TR</b>
<b>DID C2062H TR</b>	<b>DID C2062HD TR</b>	<b>DID C2062HN TR</b>	<b>DID C2062HWG TR</b>	<b>DID C2062HLX TR</b>	<b>DID C2062HLXN TR</b>	<b>DID C2062HUR TR</b>	<b>DID C2062HURN TR</b>
<b>DID C2080H TR</b>	<b>DID C2080HD TR</b>	<b>DID C2080HN TR</b>	<b>DID C2080HWG TR</b>			<b>DID C2080HUR TR</b>	<b>DID C2080HURN TR</b>
<b>DID C2082H TR</b>	<b>DID C2082HD TR</b>	<b>DID C2082HN TR</b>	<b>DID C2082HWG TR</b>			<b>DID C2082HUR TR</b>	<b>DID C2082HURN TR</b>
<b>DID C2100H TR</b>	<b>DID C2100HD TR</b>	<b>DID C2100HN TR</b>	<b>DID C2100HWG TR</b>				
<b>DID C2102H TR</b>	<b>DID C2102HD TR</b>	<b>DID C2102HN TR</b>	<b>DID C2102HWG TR</b>				

# Small Conveyor Chains **Overturn Prevention Type Top Roller Chain**

Top Roller Chains are also available with guide links that prevent overturning of loads by suppressing chain inclination.

## [Type indication]

Guide links are attached to inner link plates unless specified otherwise.

**DID 50 2P-TR-F (6P-TGI)**

Top roller chain

Guide links are attached to the inner plates of every six links. (TG stands for T-shaped guide.)

This guide link is not available for single pitch every-link top roller chains. SK1 standard attachment is used as the guide links for single pitch chains.

## Guide link on inner link plates for single pitch chain

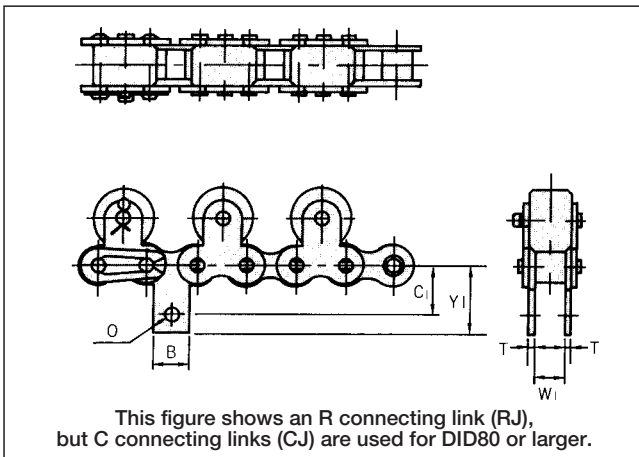

## Guide link on outer link plates for single pitch chain

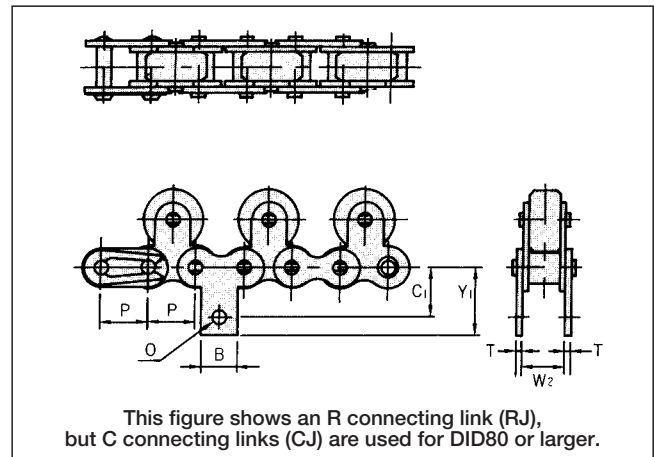

## Dimensions of TG link for single pitch chain Unit (mm)

Chain No.	Pitch P	Dimensions						
		B	Y <sub>1</sub>	C <sub>1</sub>	T	W <sub>1</sub>	W <sub>2</sub>	O
<b>DID 40 TG</b>	12.70	9.5	17.50	12.70	1.5	7.95	11.23	3.5
<b>DID 50 TG</b>	15.875	12.7	22.60	15.88	2.0	9.53	13.90	5.2
<b>DID 60 TG</b>	19.05	15.9	26.20	18.26	2.4	12.70	17.81	5.2
<b>DID 80 TG</b>	25.40	19.1	34.05	24.61	3.2	15.88	22.66	6.8
<b>DID100 TG</b>	31.75	25.4	42.75	31.75	4.0	19.05	27.51	8.7

## Chain No. - Top Roller Chain Overturn Prevention Series (Single Pitch)

Standard	Long life	Rustless	Double guard	O-ring	O-ring (rustless)	Sintered	Sintered (rustless)
<b>DID 40 TG</b>	<b>DID 40D TG</b>	<b>DID 40N TG</b>	<b>DID 40WG TG</b>	<b>DID 40LX TG</b>	<b>DID 40LXN TG</b>	<b>DID C40UR TG</b>	<b>DID C40URN TG</b>
<b>DID 50 TG</b>	<b>DID 50D TG</b>	<b>DID 50N TG</b>	<b>DID 50WG TG</b>	<b>DID 50LX TG</b>	<b>DID 50LXN TG</b>	<b>DID C50UR TG</b>	<b>DID C50URN TG</b>
<b>DID 60 TG</b>	<b>DID 60D TG</b>	<b>DID 60N TG</b>	<b>DID 60WG TG</b>	<b>DID 60LX TG</b>	<b>DID 60LXN TG</b>	<b>DID C60UR TG</b>	<b>DID C60URN TG</b>
<b>DID 80 TG</b>	<b>DID 80D TG</b>	<b>DID 80N TG</b>	<b>DID 80WG TG</b>	<b>DID 80LD TG</b>	<b>DID 80LDN TG</b>	<b>DID C80UR TG</b>	<b>DID C80URN TG</b>
<b>DID100 TG</b>	<b>DID100D TG</b>	<b>DID100N TG</b>	<b>DID100WG TG</b>	<b>DID100LD TG</b>	<b>DID100LDN TG</b>		

[Type indication]

Guide links are attached to inner link plates unless specified otherwise.

**DID C2050 1P-TR-F (6P-TG inner)**

Top roller chain  
 Guide links are attached to the inner plates of every six links. (TG stands for T-shaped guide.)

Guide links for double pitch chains can not be attached to outer plates.

**Guide link for double pitch chain**

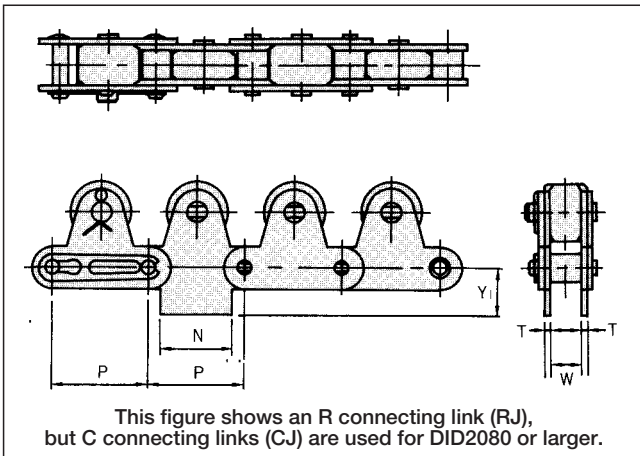

**Dimensions of TG link for double pitch chain**

Unit (mm)

Chain No.	Pitch P	Dimensions			
		N	Y <sub>1</sub>	T	W
DID C2040 TG	25.40	19.1	12.7	1.5	7.95
DID C2050 TG	31.75	23.8	15.9	2.0	9.53
DID C2060H TG	38.10	28.6	19.1	3.2	12.70
DID C2080H TG	50.80	38.1	25.4	4.0	15.88
DID C2100H TG	63.50	47.6	31.8	4.8	19.05

**Chain No. - Top Roller Chain Overturn Prevention Series (Double Pitch)**

Standard	Long life	Rustless	Double guard	O-ring	O-ring (rustless)	Sintered	Sintered (rustless)
DID C2040 TG	DID C2040D TG	DID C2040N TG	DID C2040WG TG	DID C2040LX TG	DID C2040LXN TG	DID C2040UR TG	DID C2040URN TG
DID C2042 TG	DID C2042D TG	DID C2042N TG	DID C2042WG TG	DID C2042LX TG	DID C2042LXN TG	DID C2042UR TG	DID C2042URN TG
DID C2050 TG	DID C2050D TG	DID C2050N TG	DID C2050WG TG	DID C2050LX TG	DID C2050LXN TG	DID C2050UR TG	DID C2050URN TG
DID C2052 TG	DID C2052D TG	DID C2052N TG	DID C2052WG TG	DID C2052LX TG	DID C2052LXN TG	DID C2052UR TG	DID C2052URN TG
DID C2060H TG	DID C2060HD TG	DID C2060HN TG	DID C2060HWG TG	DID C2060HLX TG	DID C2060HLXN TG	DID C2060HUR TG	DID C2060HURN TG
DID C2062H TG	DID C2062HD TG	DID C2062HN TG	DID C2062HWG TG	DID C2062HLX TG	DID C2062HLXN TG	DID C2062HUR TG	DID C2062HURN TG
DID C2080H TG	DID C2080HD TG	DID C2080HN TG	DID C2080HWG TG			DID C2080HUR TG	DID C2080HURN TG
DID C2082H TG	DID C2082HD TG	DID C2082HN TG	DID C2082HWG TG			DID C2082HUR TG	DID C2082HURN TG
DID C2100H TG	DID C2100HD TG	DID C2100HN TG	DID C2100HWG TG				
DID C2102H TG	DID C2102HD TG	DID C2102HN TG	DID C2102HWG TG				

Roller Chains for Power Transmission

Others

## Single pitch side roller chains

A side roller chain receives the load of conveyed articles by side rollers, and is used for a free flow conveyor running on rails. Since the number of rollers for receiving the load of conveyed articles is larger, a side roller chain can convey heavier articles than a top roller chain made of the same material. Furthermore, since the center of gravity of the chain is low, stability is also better. For selection and design of chain, see P212. All the connecting links of side roller chains are cotter types (C connecting links) as illustrated.

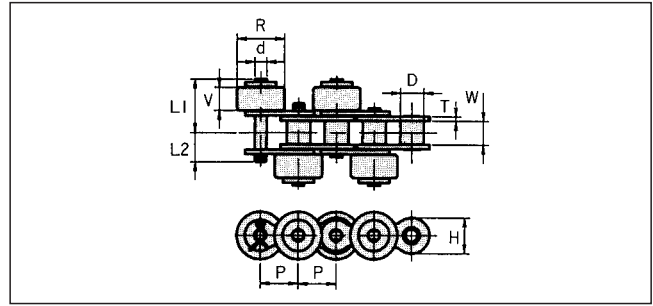

### [Type indication]

**DID 40 1P-SR-JT**

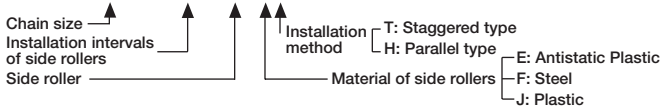

Unit (mm)

Chain No.	Pitch <b>P</b>	Roller link width <b>W</b>	Roller (bush) dia. <b>D</b>	Plate		Pin			Side roller		Avg. tensile strength		Max. allowable load		Approx. weight (kg/ pc.)		
				<b>T</b>	<b>H</b>	<b>d</b>	<b>L<sub>1</sub></b>	<b>L<sub>2</sub></b>	<b>L<sub>3</sub></b>	<b>R</b>	<b>V</b>	kN	kgf	kN	kgf	Plastic side roller	Iron side roller
<b>DID 40 SR</b>	12.70	7.95	7.92	1.5	12.0	3.97	17.7	10.1	19.5	15.88	7.8	16.6	1,700	2.64	270	0.004	0.013
<b>DID 50 SR</b>	15.875	9.53	10.16	2.0	15.0	5.09	21.7	12.0	23.5	19.05	9.4	27.9	2,850	4.41	450	0.007	0.023
<b>DID 60 SR</b>	19.05	12.70	11.91	2.4	18.1	5.96	27.8	15.1	30.3	22.23	12.6	40.2	4,100	6.37	650	0.013	0.042
<b>DID 80 SR</b>	25.40	15.88	15.88	3.2	24.0	7.94	35.1	19.0	37.7	28.58	15.8	78.4	8,000	10.7	1,100	0.026	0.086
<b>DID100 SR</b>	31.75	19.05	19.05	4.0	29.9	9.54	42.4	22.8	45.4	39.69	19.0	118.0	12,100	17.1	1,750	0.084	0.197

Note: 1. L<sub>3</sub> indicates the value of L<sub>1</sub> when cotter type pins are used.  
2. The material of plastic side roller is polyacetal.

## Chain No. - Side Roller Chain Series (Single Pitch)

Standard	Long life	Rustless	Double guard	O-ring	O-ring (rustless)	Sintered	Sintered (rustless)
<b>DID 40 SR</b>	<b>DID 40D SR</b>	<b>DID 40N SR</b>	<b>DID 40WG SR</b>	<b>DID 40LX SR</b>	<b>DID 40LXN SR</b>	<b>DID C40UR SR</b>	<b>DID C40URN SR</b>
<b>DID 50 SR</b>	<b>DID 50D SR</b>	<b>DID 50N SR</b>	<b>DID 50WG SR</b>	<b>DID 50LX SR</b>	<b>DID 50LXN SR</b>	<b>DID C50UR SR</b>	<b>DID C50URN SR</b>
<b>DID 60 SR</b>	<b>DID 60D SR</b>	<b>DID 60N SR</b>	<b>DID 60WG SR</b>	<b>DID 60LX SR</b>	<b>DID 60LXN SR</b>	<b>DID C60UR SR</b>	<b>DID C60URN SR</b>
<b>DID 80 SR</b>	<b>DID 80D SR</b>	<b>DID 80N SR</b>	<b>DID 80WG SR</b>	<b>DID 80LX SR</b>	<b>DID 80LXN SR</b>	<b>DID C80UR SR</b>	<b>DID C80URN SR</b>
<b>DID100 SR</b>	<b>DID100D SR</b>	<b>DID100N SR</b>	<b>DID100WG SR</b>	<b>DID100LX SR</b>	<b>DID100LXN SR</b>		

## Double pitch side roller chains

### S-roller type

### [Type indication]

**DID C2050 2P-SR-JT**

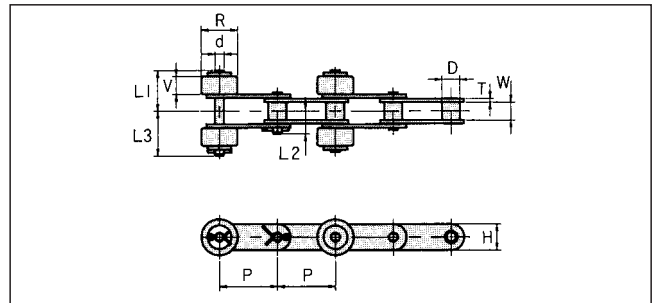
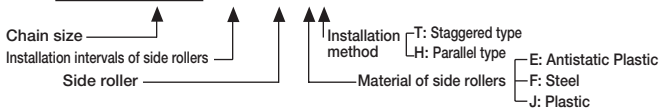

Unit (mm)

Chain No.	Pitch <b>P</b>	Roller link width <b>W</b>	Roller (bush) dia. <b>D</b>	Plate		Pin			Side roller		Avg. tensile strength		Max. allowable load		Approx. weight (kg/ pc.)		
				<b>T</b>	<b>H</b>	<b>d</b>	<b>L<sub>1</sub></b>	<b>L<sub>2</sub></b>	<b>L<sub>3</sub></b>	<b>R</b>	<b>V</b>	kN	kgf	kN	kgf	Plastic side roller	Iron side roller
<b>DID C2040 SR</b>	25.40	7.95	7.92	1.5	11.7	3.97	17.7	10.1	19.5	15.88	7.8	17.0	1,740	2.64	270	0.004	0.013
<b>DID C2050 SR</b>	31.75	9.53	10.16	2.0	15.1	5.09	21.7	12.0	23.5	19.05	9.4	28.7	2,930	4.41	450	0.007	0.023
<b>DID C2060H SR</b>	38.10	12.70	11.91	3.2	17.2	5.96	29.4	17.0	32.0	22.23	12.6	40.2	4,100	6.47	660	0.013	0.042
<b>DID C2080H SR</b>	50.80	15.88	15.88	4.0	23.3	7.94	36.7	20.7	39.3	28.58	15.8	68.6	7,000	11.2	1,150	0.026	0.086
<b>DID C2100H SR</b>	63.50	19.05	19.05	4.8	28.8	9.54	43.7	24.5	46.9	39.69	19.0	112.0	11,500	18.6	1,900	0.084	0.197

Note: 1. The material of plastic side roller is polyacetal.

## Chain No. - Side Roller Chain Series (Double Pitch)

Standard	Long life	Rustless	Double guard	O-ring	O-ring (rustless)	Sintered	Sintered (rustless)
<b>DID C2040 SR</b>	<b>DID C2040D SR</b>	<b>DID C2040N SR</b>	<b>DID C2040WG SR</b>	<b>DID C2040LX SR</b>	<b>DID C2040LXN SR</b>	<b>DID C2040UR SR</b>	<b>DID C2040URN SR</b>
<b>DID C2042 SR</b>	<b>DID C2042D SR</b>	<b>DID C2042N SR</b>	<b>DID C2042WG SR</b>	<b>DID C2042LX SR</b>	<b>DID C2042LXN SR</b>	<b>DID C2042UR SR</b>	<b>DID C2042URN SR</b>
<b>DID C2050 SR</b>	<b>DID C2050D SR</b>	<b>DID C2050N SR</b>	<b>DID C2050WG SR</b>	<b>DID C2050LX SR</b>	<b>DID C2050LXN SR</b>	<b>DID C2050UR SR</b>	<b>DID C2050URN SR</b>
<b>DID C2052 SR</b>	<b>DID C2052D SR</b>	<b>DID C2052N SR</b>	<b>DID C2052WG SR</b>	<b>DID C2052LX SR</b>	<b>DID C2052LXN SR</b>	<b>DID C2052UR SR</b>	<b>DID C2052URN SR</b>
<b>DID C2060H SR</b>	<b>DID C2060HD SR</b>	<b>DID C2060HN SR</b>	<b>DID C2060HWG SR</b>	<b>DID C2060HLX SR</b>	<b>DID C2060HLXN SR</b>	<b>DID C2060HUR SR</b>	<b>DID C2060HURN SR</b>
<b>DID C2062H SR</b>	<b>DID C2062HD SR</b>	<b>DID C2062HN SR</b>	<b>DID C2062HWG SR</b>	<b>DID C2062HLX SR</b>	<b>DID C2062HLXN SR</b>	<b>DID C2062HUR SR</b>	<b>DID C2062HURN SR</b>
<b>DID C2080H SR</b>	<b>DID C2080HD SR</b>	<b>DID C2080HN SR</b>	<b>DID C2080HWG SR</b>			<b>DID C2080HUR SR</b>	<b>DID C2080HURN SR</b>
<b>DID C2082H SR</b>	<b>DID C2082HD SR</b>	<b>DID C2082HN SR</b>	<b>DID C2082HWG SR</b>			<b>DID C2082HUR SR</b>	<b>DID C2082HURN SR</b>
<b>DID C2100H SR</b>	<b>DID C2100HD SR</b>	<b>DID C2100HN SR</b>	<b>DID C2100HWG SR</b>				
<b>DID C2102H SR</b>	<b>DID C2102HD SR</b>	<b>DID C2102HN SR</b>	<b>DID C2102HWG SR</b>				



## Meandering prevention chains

An R roller type double pitch chain with side rollers uses higher inner plates to keep the rail between them and prevent derailing of the R rollers. Furthermore, larger side rollers are used for higher live load capacity.

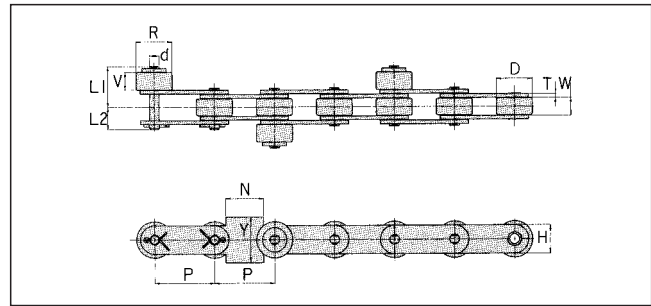

### [Type indication]

**DID C2052 2P-SG-JT**

Chain size ———— ↑  
 Installation intervals of side rollers ———— ↑  
 Meandering prevention type (Specify the intervals for the meandering prevention installation.) ———— ↑  
 Installation method ———— ↑  
 Material of side rollers ———— ↑

T: Staggered type  
 H: Parallel type  
 E: Antistatic Plastic  
 F: Steel  
 J: Plastic

Unit (mm)

Chain No.	Pitch <b>P</b>	Roller link width <b>W</b>	Roller (bush) dia. <b>D</b>	Plate		Pin			Side roller		<b>N</b>	<b>Y</b>	Approx. weight (kg/pc.)	
				<b>T</b>	<b>H</b>	<b>d</b>	<b>L<sub>1</sub></b>	<b>L<sub>2</sub></b>	<b>R</b>	<b>V</b>			Plastic side roller	Iron side roller
<b>DID C2042 SG</b>	25.40	7.95	15.88	1.5	11.7	3.97	22.9	10.1	23	13	16.5	19.0	0.016	0.043
<b>DID C2052 SG</b>	31.75	9.53	19.05	2.0	15.1	5.09	25.3	12.1	27	13	20.0	24.0	0.023	0.060
<b>DID C2062H SG</b>	38.10	12.70	22.23	3.2	17.2	5.96	29.8	17.0	30	13	25.4	27.0	0.031	0.075

Note: The material of plastic side roller is polyacetal.

## Chain No. - Side Roller Chain Meandering Prevention Series (Double Pitch)

Standard	Long life	Rustless	Double guard	O-ring	O-ring (rustless)	Sintered	Sintered (rustless)
DID C2042 SG	DID C2042D SG	DID C2042N SG	DID C2042WG SG	DID C2042LX SG	DID C2042LXN SG	DID C2042UR SG	DID C2042URN SG
DID C2052 SG	DID C2052D SG	DID C2052N SG	DID C2052WG SG	DID C2052LX SG	DID C2052LXN SG	DID C2052UR SG	DID C2052URN SG
DID C2062H SG	DID C2062HD SG	DID C2062HN SG	DID C2062HWG SG	DID C2062HLX SG	DID C2062HLXN SG	DID C2062HUR SG	DID C2062HURN SG

# Small Conveyor Chains **Free Flow Chain with Breaks**

If the revolution friction resistance of the roller is too small, loads can be stuck with the slightest friction. The revolution friction resistance of the Free Flow Chain is enhanced by applying breaks for some of the rollers to prevent accumulation of loads.

## Top Roller Chain with Breaks (TRB)

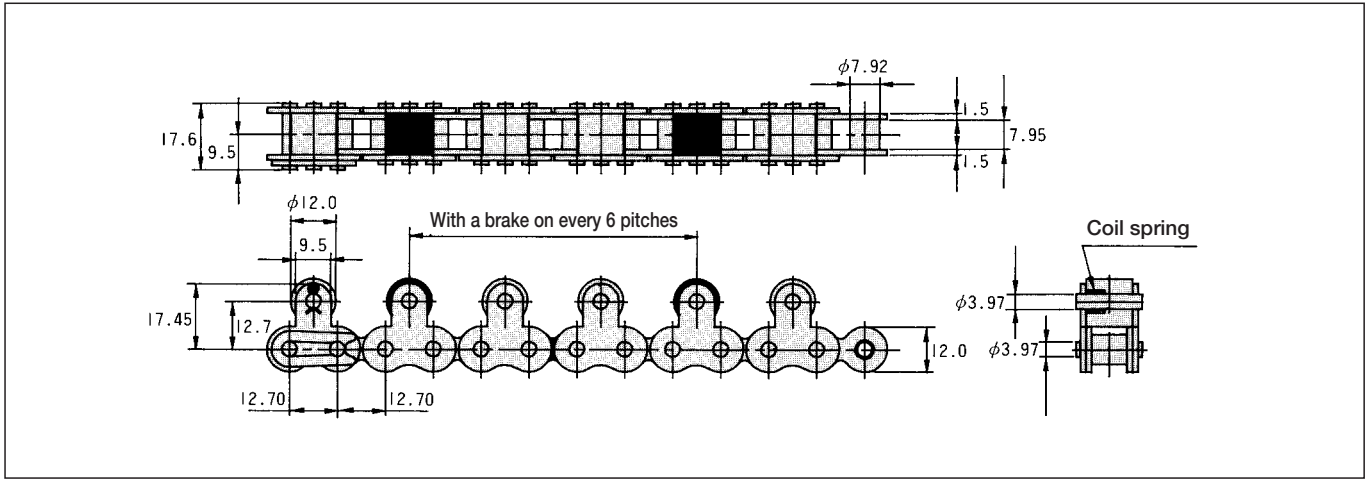

The above figure is an example of DID40 Top Roller Chain with breaks.

### Side Roller Chain with Breaks (TRB)

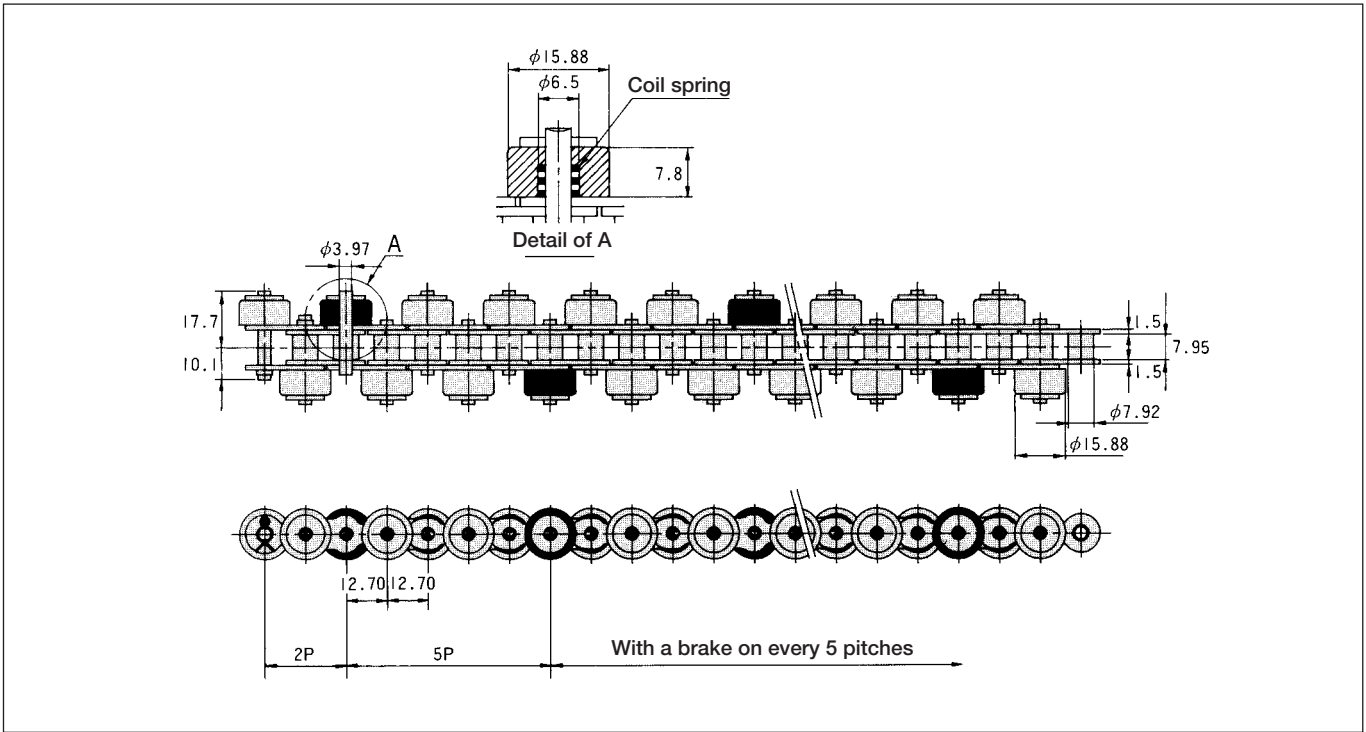

The above figure is an example of DID40 Side Roller Chain with breaks.

Roller Chains for Power Transmission  
Others

## ● Single pitch chain

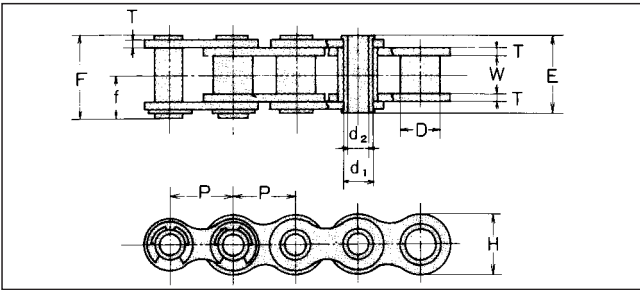

This chain is connected by hollow pins, and the hollows can be used to attach various attachments. In hollow pin chain, the hollow pins are the same as the bushings of the corresponding standard chain in diameter, so hollow pin chain can be regarded as bushing chain that contains bushings of the same diameter as that of the rollers of the corresponding standard chain.

Standard sprockets can be used.

For design of chain transmission, refer to the slow-speed selection on P121.

The connecting links are special snap ring types for hollow pin chain as illustrated.

Since no offset link is available, the number of links should be an even number.

Unit (mm)

Chain No.	Pitch <b>P</b>	Roller link width <b>W</b>	bush dia. <b>D</b>	Pin			Plate		Avg. tensile strength		Max. allowable load		Approx. weight (kg/m)		
				<b>d<sub>1</sub></b>	<b>d<sub>2</sub></b>	<b>E</b>	<b>F</b>	<b>f</b>	<b>T</b>	<b>H</b>	kN	kgf		kN	kgf
<b>DID 40HP</b>	12.70	7.95	7.92	5.62	4.00	16.0	17.5	9.5	1.5	12.0	10.7	1,000	1.76	180	0.52
<b>DID 50HP</b>	15.875	9.53	10.16	7.20	5.12	20.2	21.7	11.6	2.0	15.0	19.6	2,000	3.13	320	0.86
<b>DID 60HP</b>	19.05	12.70	11.91	8.45	5.99	25.1	26.8	14.3	2.4	18.1	26.4	2,700	4.31	440	1.20

Note: The values of average tensile strength and maximum allowable load are for chains.

## ● Double pitch chain

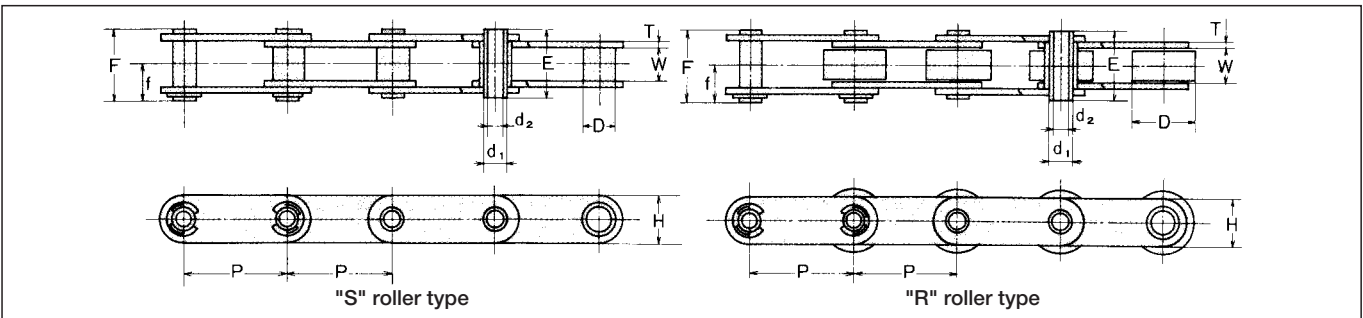

Unit (mm)

Chain No.	Pitch <b>P</b>	Roller link width <b>W</b>	Roller (bush) dia. <b>D</b>	Pin			Plate		Avg. tensile strength		Max. allowable load		Approx. weight (kg/m)		
				<b>d<sub>1</sub></b>	<b>d<sub>2</sub></b>	<b>E</b>	<b>F</b>	<b>f</b>	<b>T</b>	<b>H</b>	kN	kgf		kN	kgf
<b>DID C2040HP</b>	25.40	7.95	7.92	5.62	4.00	16.0	17.5	9.5	1.5	11.7	10.7	1,100	1.76	180	0.44
<b>DID C2042HP</b>			15.88												0.81
<b>DID C2050HP</b>	31.75	9.53	10.16	7.20	5.12	20.2	21.7	11.6	2.0	15.1	19.6	2,000	3.13	320	0.75
<b>DID C2052HP</b>			19.05												1.21
<b>DID C2060HP</b>	38.10	12.70	11.91	8.45	5.99	25.1	26.8	14.3	2.4	17.2	26.4	2,700	4.21	430	1.32
<b>DID C2062HP</b>			22.23												2.79
<b>DID C2080HP</b>	50.80	15.88	15.88	11.30	8.02	32.5	34.1	17.8	3.2	23.3	48.0	4,900	7.65	780	1.72
<b>DID C2082HP</b>			28.58												2.67

Note: The values of average tensile strength and maximum allowable load are for chains.

## Chain No. - Hollow Pin Chain Series (Single Pitch)

Standard	Rustless	Double guard
<b>DID 40HP</b>	<b>DID 40HPN</b>	<b>DID 40HPWG</b>
<b>DID 50HP</b>	<b>DID 50HPN</b>	<b>DID 50HPWG</b>
<b>DID 60HP</b>	<b>DID 60HPN</b>	<b>DID 60HPWG</b>

## (Double Pitch)

Standard	Rustless	Double guard
<b>DID C2040HP</b>	<b>DID C2040HPN</b>	<b>DID C2040HPWG</b>
<b>DID C2042HP</b>	<b>DID C2042HPN</b>	<b>DID C2042HPWG</b>
<b>DID C2050HP</b>	<b>DID C2050HPN</b>	<b>DID C2050HPWG</b>
<b>DID C2052HP</b>	<b>DID C2052HPN</b>	<b>DID C2052HPWG</b>
<b>DID C2060HP</b>	<b>DID C2060HPN</b>	<b>DID C2060HPWG</b>
<b>DID C2062HP</b>	<b>DID C2062HPN</b>	<b>DID C2062HPWG</b>
<b>DID C2080HP</b>	<b>DID C2080HPN</b>	<b>DID C2080HPWG</b>
<b>DID C2082HP</b>	<b>DID C2082HPN</b>	<b>DID C2082HPWG</b>

DID Flexible Chain has great sideward bending flexibility and is suitable for curved traveling. Sprockets for JIS/ANSI Standard Roller Chain can be used for this chain. By fixing attachments, this chain can be used for curved transfer with conveyors.

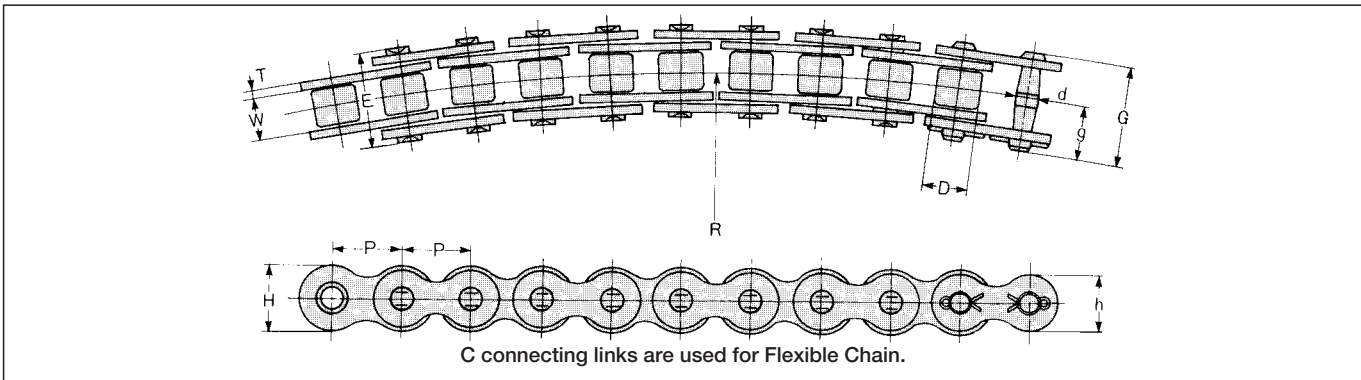
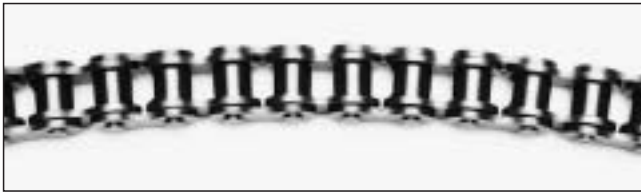

Unit (mm)

Chain No.	Pitch	Roller link width	Roller dia.	Pin				Plate			Min. lateral bending radius R	Avg. tensile strength		Max. allowable load		Approx. weight (kg/m)
	P	W	D	d	E	G	g	T	H	h		kN	kgf	kN	kgf	
<b>DID 40FX</b>	12.70	7.95	7.92	3.97	16.9	18.6	10.4	1.5	12.0	10.4	350	15.7	1,600	1.86	190	0.60
<b>DID 50FX</b>	15.875	9.53	10.16	5.09	20.7	22.0	11.9	2.0	15.0	13.0	400	24.5	2,500	2.84	290	1.03
<b>DID 60FX</b>	19.05	12.70	11.91	5.96	25.8	28.4	15.4	2.4	18.1	15.6	500	35.3	3,600	4.02	410	1.31
<b>DID 80FX</b>	25.40	15.88	15.88	7.94	33.8	36.5	19.5	3.2	24.0	20.8	600	61.8	6,300	6.96	710	2.60

Note 1. The radius of the curve must be set larger than the values above.  
 2. The values of average tensile strength and maximum allowable load are for chains.

## Chain No. - Flexible Chain Series

Standard	Long life	Rustless	Double guard
<b>DID 40FX</b>	<b>DID 40FXD</b>	<b>DID 40FXN</b>	<b>DID 40FXWG</b>
<b>DID 50FX</b>	<b>DID 50FXD</b>	<b>DID 50FXN</b>	<b>DID 50FXWG</b>
<b>DID 60FX</b>	<b>DID 60FXD</b>	<b>DID 60FXN</b>	<b>DID 60FXWG</b>
<b>DID 80FX</b>	<b>DID 80FXD</b>	<b>DID 80FXN</b>	<b>DID 80FXWG</b>

# Small Conveyor Chains Flat Type Roller Chain

This chain is suited for conveyor systems because it has flat plates that cause little damage to components such as chain guides. (The forms of outer plates and inner plates are the same.)

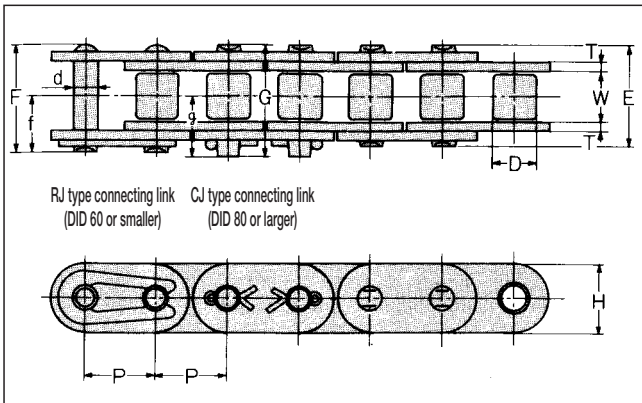

Unit (mm)

Chain No.	Pitch P	Roller link width W	Roller (Bush) dia. D	Pin						Plate		Avg. tensile strength		Avg. tensile strength (kg/m)
				d	E	F	G	g	f	T	H	kN	kgf	
<b>DID35F</b>	9.525	4.78	(5.08)	3.59	12.0	13.1	—	—	7.3	1.25	9.0	11.2	1,150	0.39
<b>DID40F</b>	12.70	7.95	7.92	3.97	16.5	17.6	—	—	9.5	1.5	12.0	19.1	1,950	0.65
<b>DID50F</b>	15.875	9.53	10.16	5.09	20.3	21.9	—	—	11.6	2.0	15.0	30.8	3,150	1.15
<b>DID60F</b>	19.05	12.70	11.91	5.96	25.4	26.9	—	—	14.3	2.4	18.1	44.1	4,500	1.70
<b>DID80F</b>	25.40	15.88	15.88	7.94	32.6	—	35.4	19.0	—	3.2	24.0	78.4	8,000	2.67
<b>DID100F</b>	31.75	19.05	19.05	9.54	39.5	—	42.5	22.7	—	4.0	29.9	118	12,100	4.19
<b>DID120F</b>	38.10	25.40	22.23	11.11	49.7	—	53.0	28.2	—	4.8	35.9	166	17,000	6.12

Note: Consult us for sizes other than the above.

## Chain No. - Flat Type Roller Chain Series

Standard	Long life	Rustless	Double guard	High guard	O-ring	O-ring (rustless)
<b>DID 35F</b>	<b>DID 35FD</b>	<b>DID 35FN</b>	<b>DID 35FWG</b>	<b>DID 35FE</b>	<b>DID 35FLD</b>	<b>DID 35FLDN</b>
<b>DID 40F</b>	<b>DID 40FD</b>	<b>DID 40FN</b>	<b>DID 40FWG</b>	<b>DID 40FE</b>	<b>DID 40FLX</b>	<b>DID 40FLXN</b>
<b>DID 50F</b>	<b>DID 50FD</b>	<b>DID 50FN</b>	<b>DID 50FWG</b>	<b>DID 50FE</b>	<b>DID 50FLX</b>	<b>DID 50FLXN</b>
<b>DID 60F</b>	<b>DID 60FD</b>	<b>DID 60FN</b>	<b>DID 60FWG</b>	<b>DID 60FE</b>	<b>DID 60FLX</b>	<b>DID 60FLXN</b>
<b>DID 80F</b>	<b>DID 80FD</b>	<b>DID 80FN</b>	<b>DID 80FWG</b>	<b>DID 80FE</b>	<b>DID 80FLD</b>	<b>DID 80FLDN</b>
<b>DID 100F</b>	<b>DID 100FD</b>	<b>DID 100FN</b>	<b>DID 100FWG</b>	<b>DID 100FE</b>	<b>DID 100FLD</b>	<b>DID 100FLDN</b>
<b>DID 120F</b>	<b>DID 120FD</b>	<b>DID 120FN</b>	<b>DID 120FWG</b>	<b>DID 120FE</b>	<b>DID 120FLD</b>	<b>DID 120FLDN</b>



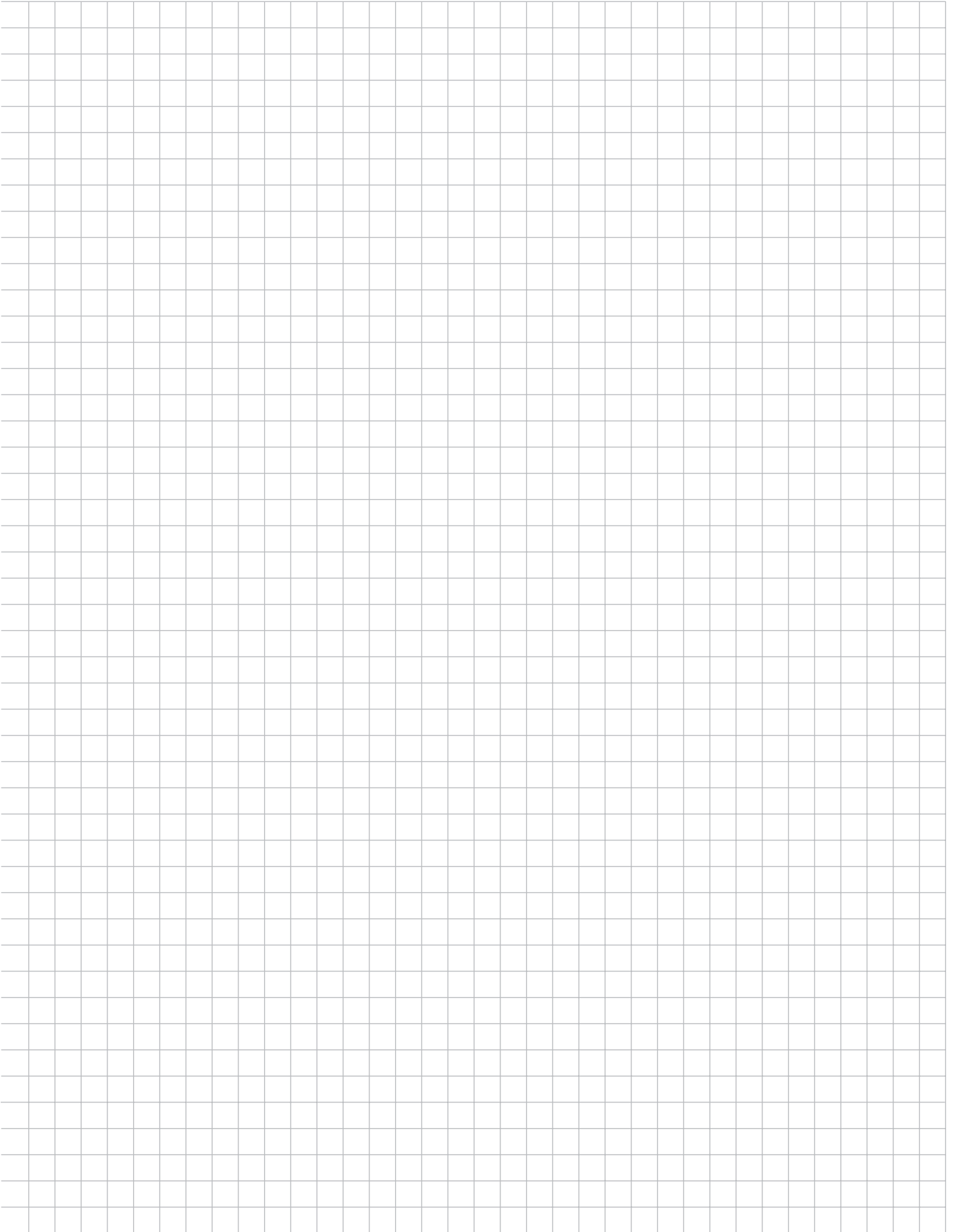

When you design various conveyor systems using DID small conveyor chains, the following basic conditions must be satisfied.

- a. Chain tension: The actual tensile strength in operation must be significantly lower than the specified strength of the chain.
- b. Strength of loaded components of chain: The actual loads applied to attachments, such as rollers of base chain, top rollers, side rollers, etc. in operation must be significantly smaller than the strength of these components.
- c. Wear life of chain: Lubrication conditions to ensure the wear life of chain must be fulfilled.
- d. Sag adjustment of chain: The sag of the chain must be kept optimum by tension adjusters, take-up devices, guides, etc.
- e. Others: Appropriate measures are taken to prevent rail wear, machine vibration and other problems.

The following complement the above.

## Calculation of Chain Tension

In general, at first, tentatively determine the chain size to be used referring to "Tentative determination of chain size". Then, obtain "Theoretical chain tension (T)" (P213) for the tentatively determined chain, and multiply the value by "Speed coefficient (K)", to obtain "Substantial chain tension (Ta)". For safety, the substantial chain tension must be lower than the "maximum allowable tension" stated in the table of dimensions of respective chains. Consequently, the condition below should be satisfied.

### Safety condition of chain tension

$$\text{Substantial chain tension (Ta)} = \text{Theoretical chain tension (T)} \times \text{Speed coefficient (K)}$$

$$\text{Substantial chain tension (Ta)} < \text{Maximum allowable tension}$$

If this condition is not satisfied, select a larger chain by one size and re-calculate.

### Tentative determination of chain size

- ① Determine the mass (weight) per unit length of components such as chain and attachment  $\omega c$  (kg/m or kgf/m) assuming that it is 10 % of the mass (weight) of the conveyed object  $\omega 1$  (kg/m or kgf/m).
- ② In reference to the calculation formulas on P213, obtain "Theoretical chain tension (T)" (kN or kgf) and "Speed coefficient (K)", and calculate "Substantial chain tension (Ta)" (kN or kgf).
- ③ In reference to the table of dimensions of chains, identify the minimum chain, whose "maximum allowable tension" is higher than the "Substantial chain tension (Ta)", and regard it as "tentatively decided chain".

### Value of speed coefficient (K)

The speed coefficient (K) expresses the severity of operation condition according to the traveling speed of chain since the condition becomes severer as the traveling speed of chain becomes higher. Multiply "Theoretical chain tension (T)" by "Speed coefficient (K)" to obtain "Substantial chain tension (Ta)".



#### Speed coefficient K

Chain speed (m/min)	Speed coefficient
Less than 15	1.0
15~30	1.2
30~50	1.4
50~70	1.6
70~90	2.2
90~110	2.8
110~120	3.2

When plastic rollers (including anti-static rollers) are used, run the chain at the speed of 70 m/min or less.

Note: When the chain speed exceeds 120 m/min, please consult us.

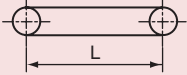
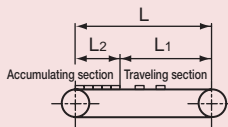
## Calculation formulas of theoretical chain tension (T)

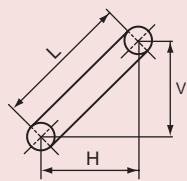
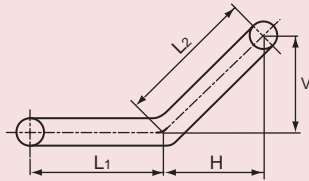
Conveying method	Calculation formulas of theoretical chain tension T
<p>To convey articles horizontally</p> 	$T = (W + 2.1 \times \omega_c \times L) \times f_1 \times \frac{g}{1,000}$ $kW = \frac{T \times S}{52.2 \times \eta}$
<p>To convey articles horizontally and accumulate them (free flow conveyor)</p> 	$T = \{ (\omega_1 + \omega_c) \times L_1 \times f_1 + \omega_2 \times L_2 \times f_2 + (\omega_2 + \omega_c) \times L_2 \times f_3 + 1.1 \times \omega_c \times L \times f_1 \} \times \frac{g}{1,000}$ $kW = \frac{T \times S}{52.2 \times \eta}$
<p>To convey articles vertically.</p> 	$T = (W + \omega_c \times V) \times \frac{g}{1,000}$ $kW = \frac{W \times S}{52.2 \times \eta}$
<p>To convey articles on a slope</p> 	$T = \{ (W + \omega_2 \times L) \times \frac{H \times f_1 + V}{L} + 1.1 \times \omega_c (H \times f_1 - V) \} \times \frac{g}{1,000}$ $kW = \frac{S}{52.2 \times \eta} \{ T + \omega_c \times (H \times f_1 - V) \}$
<p>To convey articles on a slope and horizontal plane</p> 	$T = \{ (\frac{W}{L_1 + L_2} + 2.1 \times \omega_c) \times L_1 \times f_1 + (\frac{W}{L_1 + L_2} + \omega_c) \times (H \times f_1 + V) + 1.1 \times \omega_c (H \times f_1 - V) \} \times \frac{g}{1,000}$ $kW = \frac{S}{52.2 \times \eta} \{ T + \omega_c \times (H \times f_1 - V) \}$

**Symbols:**

- T : Theoretical chain tension
- W : Total mass (total weight) of the load on the conveyor
- $\omega_1$  : Mass (weight) of load per unit length in the traveling section  
 $\omega_1 = \text{Total mass (total weight) of load in the traveling section (kg or kgf)} \div \text{Length of traveling section } L_1 \text{ (m)}$
- $\omega_2$  : Mass (weight) of load per unit length in the accumulating section  
 $\omega_2 = \text{Total mass (total weight) of load in the accumulating section (kg or kgf)} \div \text{Length of accumulating section } L_2 \text{ (m)}$
- $\omega_3$  : Mass (weight) of components such as chain and attachments per unit length
- S : Chain speed (traveling speed of chain) m/min.
- $\eta$  : Transmission efficiency of drive section
- g : Gravitational acceleration = 9.80665 m/s<sup>2</sup>
- kW : Required power
  - As for L, L1, L2, V and H, see the illustrations showing conveying methods.
  - As for coefficients of friction f1, f2 and f3, see P214.

**SI units**

- kN
- kg
- kg/m
- kg/m
- kg/m
- m/分

## Values of coefficients of friction

$f_1$ : Coefficient of friction of traveling chain. See the following tables according to the cases.

- When the rollers of chain roll on rails .....Table 1
- When side rollers roll on the floor .....Table 2
- When plates slide on rails such as the case of flat type chain .....Table 3

The same values can be used for  $f_1$  of the traveling section of free flow conveyor.

$f_3$ : Coefficient of friction acting between the chain and rail in the accumulating section of free flow conveyor. In the cases other than double speed free flow conveyor, see Table 1~3 since  $f_1$  equals  $f_3$ .

Table 1

$f_1$ used when the rollers of chain roll			
Chain type		Lubrication	
		Not provided	Provided
Chain with iron rollers	<b>S</b> rollers	0.21	0.14
	<b>R</b> rollers	0.12	0.08
Chain with plastic rollers	<b>S</b> rollers	0.12	—
	<b>R</b> rollers	0.08	—
Chain with sintered bushing rollers	<b>S</b> rollers	0.14	—
	<b>R</b> rollers	0.08	—

Table 2

$f_1$ used when side rollers roll on the floor		
Chain type	Lubrication	
	Not provided	Provided
Chain with iron rollers	0.09	0.06
Chain with plastic rollers	0.06	—
Chain with anti-static plastic rollers	0.06	—
Chain with plastic rollers and brakes	0.09	—

Table 3

$f_1$ used when the plates of chain slide (in the case of iron rail)	
Without lubrication <b>0.3</b>	With lubrication <b>0.2</b>

$f_2$ : Coefficient of friction acting between conveyed articles and chain in the accumulating section of free flow conveyor

That is, it is a frictional resistance when the side rollers or top rollers roll while being loaded with articles. Table 4 shows the values

Table 4

Type of side rollers or top rollers	$f_2$	
	Without lubrication	With lubrication
Iron rollers	0.09	0.06
Plastic rollers	0.06	—
Anti-static plastic rollers	0.06	—
Plastic rollers with brakes	0.09	—

## Strength of Loaded Components

The load on the conveyor is applied to the attachments, top rollers, side rollers, etc. of the chain. Confirm that the strength of these components is sufficient.

Various strength calculation methods are applied according to usages of chain. Only the allowable loads of rollers of the chain, top rollers and side rollers are shown below.

### Allowable loads per one roller of chain, top roller and side roller

UnitN (kgf/pc.)

Chain No.	Roller of chain		Top roller		Side roller	
	Iron	Plastic	Iron	Plastic	Iron	Plastic
<b>DID 40</b>	156 (16)	—	156 (16)	49 (5)	156 (16)	49 (5)
<b>DID C2040</b>	156 (16)	—	156 (16)	49 (5)	156 (16)	49 (5)
<b>DID C2042</b>	627 (64)	196 (20)	156 (16)	49 (5)	156 (16)	117 (12)
<b>DID 50</b>	225 (23)	—	225 (23)	68 (7)	225 (23)	68 (7)
<b>DID C2050</b>	225 (23)	—	225 (23)	68 (7)	225 (23)	68 (7)
<b>DID C2052</b>	989 (98)	294 (30)	225 (23)	68 (7)	225 (23)	137 (14)
<b>DID 60</b>	372 (38)	—	372 (38)	107 (11)	372 (38)	107 (11)
<b>DID C2060H</b>	372 (38)	—	372 (38)	107 (11)	372 (38)	107 (11)
<b>DID C2062H</b>	1,530 (157)	490 (50)	372 (38)	107 (11)	372 (38)	156 (16)
<b>DID 80</b>	627 (64)	—	627 (64)	176 (18)	627 (64)	176 (18)
<b>DID C2080H</b>	627 (64)	—	627 (64)	176 (18)	627 (64)	176 (18)
<b>DID C2082H</b>	2,540 (260)	882 (90)	627 (64)	176 (18)	627 (64)	—
<b>DID 100</b>	912 (93)	—	912 (93)	294 (30)	912 (93)	294 (30)
<b>DID C2100H</b>	912 (93)	—	912 (93)	294 (30)	912 (93)	294 (30)
<b>DID C2102H</b>	3,660 (374)	1,270 (130)	912 (93)	294 (30)	912 (93)	—

### Examples of supporting conveyed articles

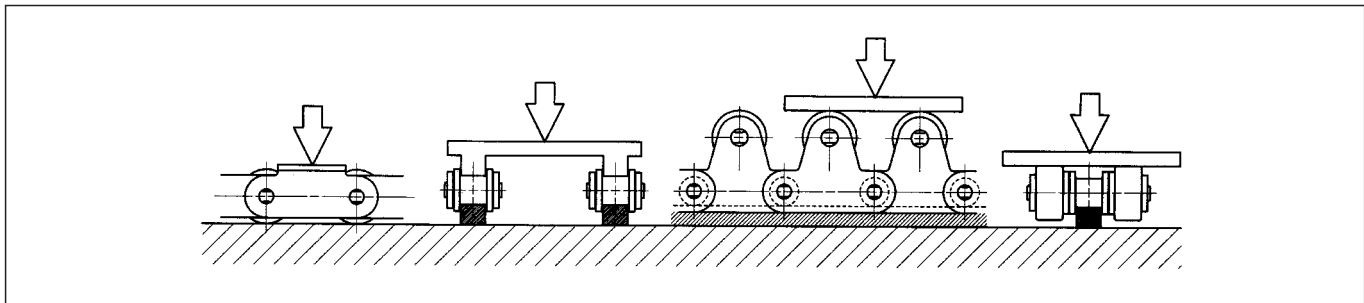

## Life of Small Conveyor Chain

The chain should be replaced when it is worn out. Select an optimal size with sufficient strength and conduct appropriate lubrication to use the chain for longer period of time. Refer to the section of Lubrication (P132). If chain sag occurs heavily, we recommend using Ultimate Life Chains.

## Adjustment of Chain Tension and Other Maintenance

See Installation, Adjustment and Maintenance for Roller Chain for Power Transmission (P127) and Conveyor Chain (P340).

# Inquiry Sheet (For Small Conveyor Chain)

When placing an order or inquiring, please fill in the following information.  
Use additional sheets when necessary.

Number of attached sheets:[    ]

	Date of inquiry:	Year	Month	Day
Name				
Department				
Company name				
Address 〒		TEL (    )	FAX (    )	
Machine concerned				
Manufacturer				
Chain currently used				
Manufacturer				

Conveyed material	Detail		
	Corrosiveness	With / without (    )	
	Abrasiveness	With / without (    )	
	Adhesion	With / without (    )	
	Temperature	Room temperature	°C
	Dimensions·Mass		kg/pc.
Service conditions	Chain	Place of installation	Indoor / outdoor (    )
		Lubrication	Delivery: With / without (    )
			During use: Impossible / Possible (Frequency    )
		Kind: Manual / Drip / Other (    )	
		Motor used	AC / DC    kW×    rpm×    unit (s)
		Chain pitch	mm
	Average tensile strength	kN (kgf)	
	Sprocket	Roller type	S / M / R / F / Special (    )
		Attachments	Installation intervals: Every    links (every    mm)
			A(    ) / K(    ) / G(    ) / SA(    ) / SK(    )
		Special (    )	
		Mirror arranged attachments	Yes / No
Sliding parts		Rollers / Plates / Other (    )	
Number of teeth of driving side	NT    (PCD    mm)		
Number of teeth of driven side	NT    (PCD    mm) / Tail drum		
Shaft hole diameter	φ    Tolerance: H7 / H8 / Other (    )		
Hub form	Type ( A / B / C )    φ    ×    L		
Key groove	No / Yes Dimensions: ANSI: b    × t (    ) Parallel or Tapered		
Tooth Finish	Precision fusion cutting / Mechanical toothed wheel cutting / Induction hardening / Hard facing		

### Notes and machine layout

Please indicate in detail the form of conveyor, loading and unloading methods, forms of attachments and rails, installation method on the return side, etc.  
Describe the maximum chain tension if it is known.  
Also indicate any problems of the machine and chain in current use.  
Inquiry sheet is also provided on our website below.  
<http://www.did-daido.co.jp>



# 3.4

# Conveyor Chains

- Outline of Conveyor Chains
- 3. DK Conveyor Chains
  - Standard Conveyor Chain
  - Anti-seizing Roller Conveyor Chain
  - Bearing Assembled Roller Conveyor Chain
  - Seal Chain
  - Strong H-type and Z-type Conveyor Chain
  - High Link-plate Chain
  - Conveyor Chain with Side Roller
  - Conveyor Chain with Top Roller
- 4. DK Specialty Conveyor Chains
  - Specialized Application Conveyor Chain
  - Water Treatment Conveyor Chain
  - 3D Bending Conveyor Chain
  - Others



## Classification

DK conveyor chains are classified into DK Conveyor Chains and DK Specialty Conveyor Chains. DK Conveyor Chains are further classified into Standard Conveyor Chain, Strong H-type Conveyor Chain and Strong Z-type Conveyor Chain, stated in the order of higher strength. For DK Conveyor Chains, a large variety of attachments and additional features are available for wide-range use. The variation of chains is described in the following section in detail.

DK Specialty Conveyor Chains are customized in dimensions and material to be the most suitable for respective applications such as continuous flow conveyors and water treatment equipment. Furthermore, the unique 3D Bending Conveyor Chains are designed to run vertically and horizontally between the ceiling and the floor for conveying lifted or dragged articles. Sprockets used for DK conveyor chains are standardized to cover various numbers of teeth. See the section of DK Conveyor Chain Sprocket (p327-341). In addition to the above conveyor chains, we can custom design special conveyor chains.

## Classification

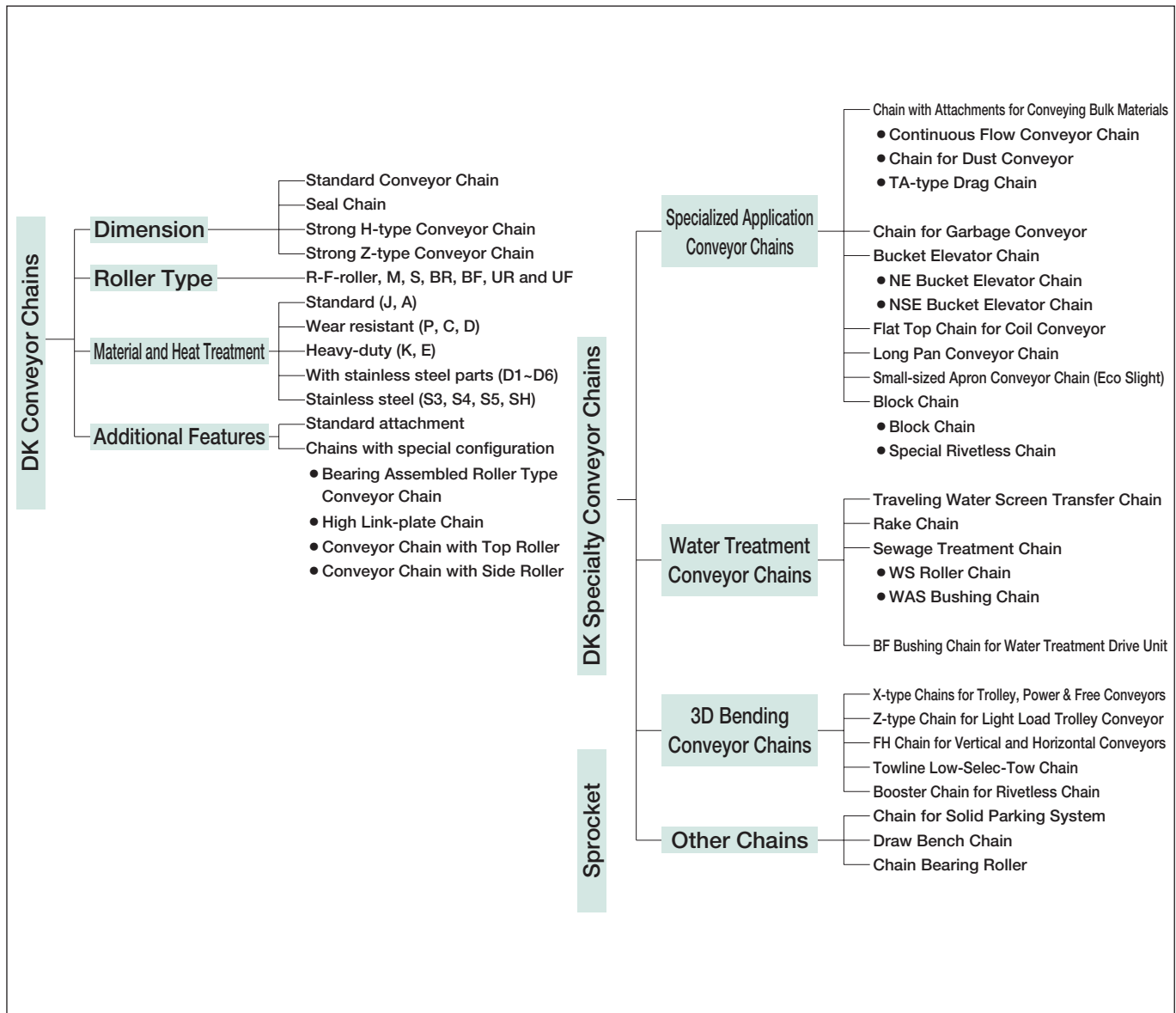

## Construction and Components of DK Conveyor Chains

A DK conveyor chain has a structure as illustrated below, and the names of the components are stated in the drawing. These components have functions specified below.

### Construction

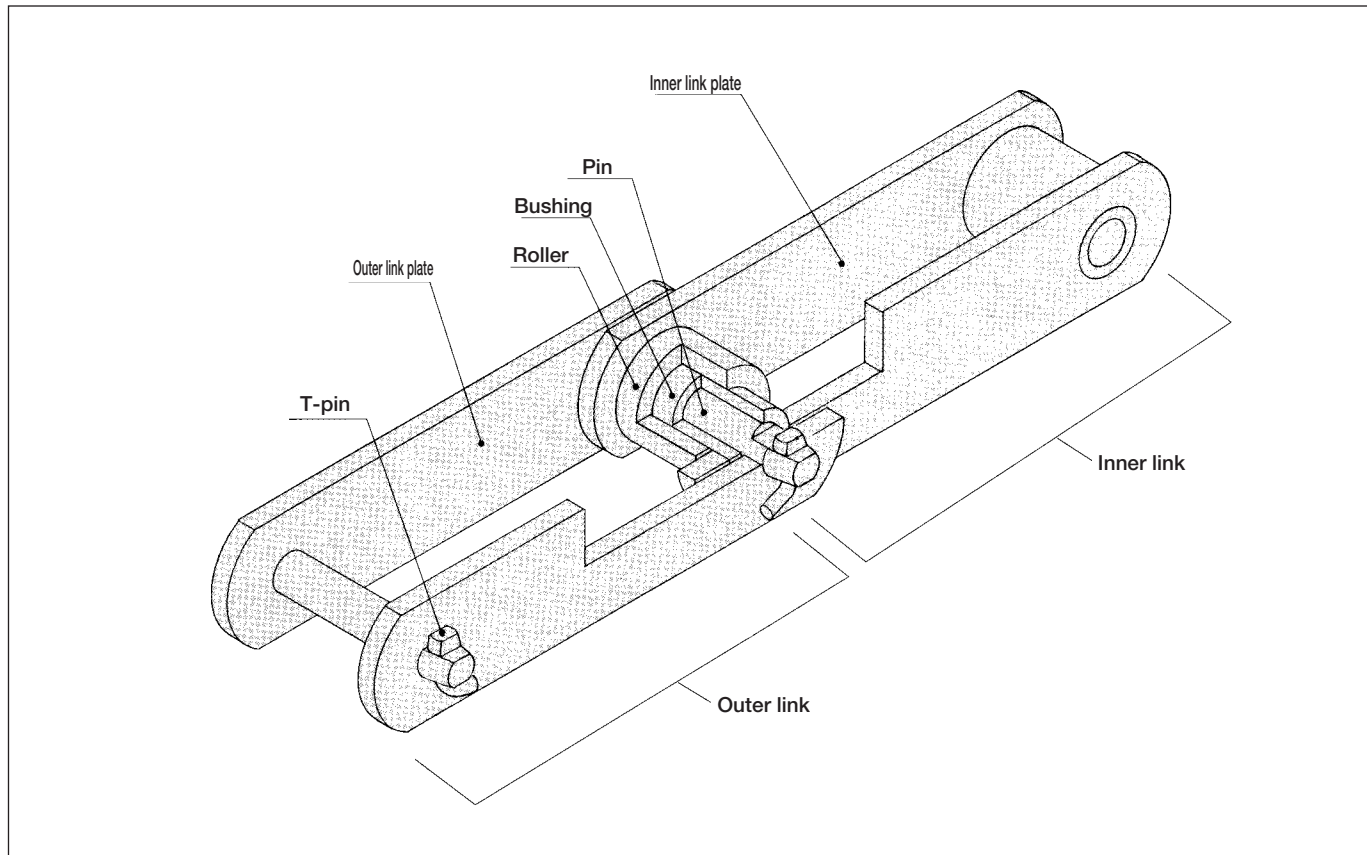

### Pins

Pins support all the load acting on the chain together with plates, and when the chain is engaged with the sprockets, they slide together with bushings as bearings. They are subject to wear and especially must have high shear strength, bending strength and wear resistance. Hardened and tempered tough steel, carburized steel, or induction-hardened steel is used.

### Rollers

Rollers protect the chain from shocks with the sprockets, and when the chain is engaged with the sprockets, the rollers bend the chain smoothly and act to lessen the resistance when the chain runs on a rail. They are required to have high shock fatigue strength, collapse strength and wear resistance. Hardened and tempered tough steel, carburized steel or induction-hardened steel is used.

### Bushings

Bushings are located between pins and rollers and act as bearings for both the pins and rollers not to transmit the load received by the rollers directly to the pins when the chain is engaged with the sprockets. They are required to have high shock fatigue strength, collapse strength and wear resistance, and in general, carburized steel is used.

### Plates

Plates are subject to repeated tension of the chain and sometimes to large shocks. They are required to have high tensile strength, and especially high shock strength and fatigue strength. High tensile steel is used for standard chains and heat-treated alloy steel for heavy-duty chains.

### T-pins

T-pins prevent the outer plates from disengaging from the pins. They are made of soft steel since pins are generally pressed-in the outer plates and thus no large force acts on the T-pins.

## How to Order DK Conveyor Chains

### ● Example 1

Chain pitch: 100 mm

Average tensile strength: 88.2 kN (9,000 kgf)

Roller type: F

Chain strength: Standard type

Attachment: A2 attachments are installed every two links

Order quantity: 100 links

[Type indication]

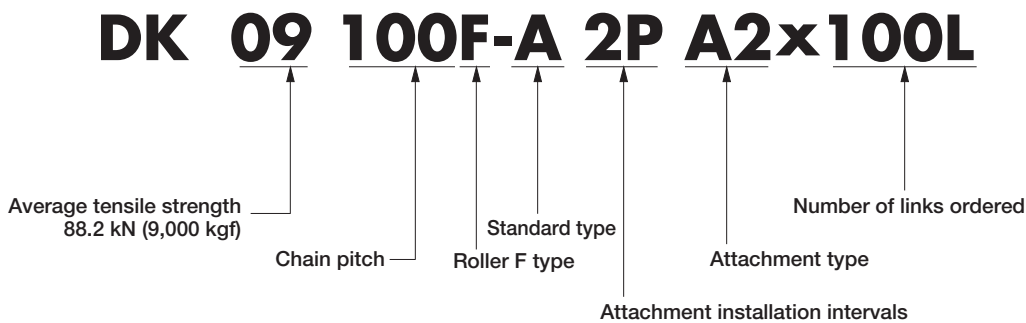

### ● Example 2

Chain pitch: 100 mm

Average tensile strength: 156 kN (16,000 kgf)

Roller type: F

Chain strength: Heavy-duty

Attachment: A2 attachments are installed every two links

Order quantity: 100 links

[Type indication]

**DK 09 100F-K 2P A2x100L**

K indicates a heavy-duty chain which has the same dimensions as a standard chain but it uses components that are made of different materials and heat-treated for higher average tensile strength of 156 kgf (16,000 kgf). See the list of specification symbols (P223) .

- When replacing existing chains, please let us know the drawing no. of the chains and order quantity.
- Consult us for new designs or inquiries.

## Variation of DK Regular Conveyor Chain

DK Conveyor Chains are available in a variety of dimensions, roller types, and material and heat treatment. Furthermore, the chains can be used for a broad range of application with our extensive selection of attachments and additional features.

### Classified by Dimensions

DK Conveyor Chains can be classified into standard, strong H-type and strong Z-type with reference to the size of the base chain.

The Standard Conveyor Chain is the basic form of DK Conveyor Chains, and many attachments, materials, heat treatments, etc. are available.

The Strong H-type Conveyor Chain was originally developed as a chain for bucket elevators with enhanced strength and is now available in a series. A small-sized Strong H-type Conveyor Chain is almost equal in strength to a large-sized Standard Conveyor Chain, but since the dimensions and form differ, sprockets are not interchangeable. Generally, Strong H-type Conveyor Chains are higher in strength than Standard Conveyor Chains with about the same roller diameter.

Strong Z-type Conveyor Chains are further enhanced in strength than Strong H-type Conveyor Chains by elevating the height of the inner plates, and the sprockets are interchangeable if the nominal number is the same. Strong H-type Conveyor Chains are used in machines in which the plates slide on the floor, such as continuous flow conveyors, since the inner and outer plates have the same height.

On the other hand, Strong Z-type Conveyor Chains exhibit high fatigue strength and are used in vertical conveyor bucket elevators.

### Classified by Roller Type

The rollers of a conveyor chain function not only to engage the sprockets moving the chain but also to rotate and travel on a rail, conveying articles with small frictional loss. To meet various shapes of rails and prevent meandering, etc., four types of rollers, large roller, flange roller, medium roller and small roller, described on the following page are available.

Furthermore, for smoother rotation, we offer large rollers and flange rollers with built-in bearings (BR and BF rollers, respectively), and UR and UF rollers with large clearances between the bushing and the roller to prevent the entry of foreign matters into the bearings. These rollers are often used in waste processing facilities.

**In this catalogue, large rollers, flange rollers, medium rollers and small rollers are respectively expressed as R-roller, F-roller, M-roller and Roller S.**

## ① R-roller

R-roller Conveyor Chains have rollers with an outer diameter larger than the width of plates.

Since the rollers can easily roll, the chain is suitable for running on the floor while the rollers receive the live load.

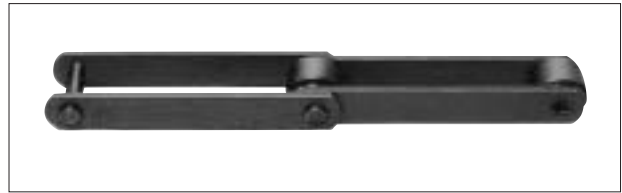
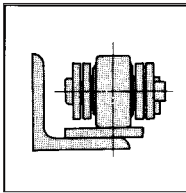

## ② F-roller

F-roller Conveyor Chains have rollers with the same outer diameter as that of R-roller but with flanges.

Since the flanges can receive the force acting on the lateral sides of the chain, the chain is suitable for receiving both a live load and a lateral load.

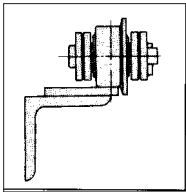

## ③ M-roller

M-roller Conveyor Chains have rollers with an outer diameter slightly smaller than the width of plates.

An M roller is designed for smoother engagement with the sprockets. Since the chain is light in weight, it is suitable for vertical conveyance.

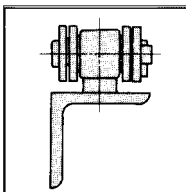

## ④ S-roller

S-roller Conveyor Chains have rollers with an outer diameter smaller than that of the M-roller.

The chain is suitable for vertical conveyance where rollers are less likely to be worn.

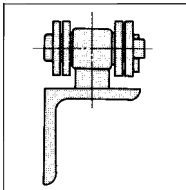

## ⑤ BR- and BF- Rollers (with built-in bearings)

BR- and BF- Roller Conveyor Chains have mostly identical structure to R-roller and F Conveyor Chains, respectively, except for the bearings inside for smoother rotation.

## ⑥ UR- and UF- Rollers (large clearance between bushing and roller)

UR- and UF- Roller Conveyor Chains have mostly identical structure to R-roller and F Conveyor Chains, respectively. However, the clearances between the outer diameter of bushings and the inner diameter of the rollers are enlarged to prevent the rollers from fixing when foreign matters enter.

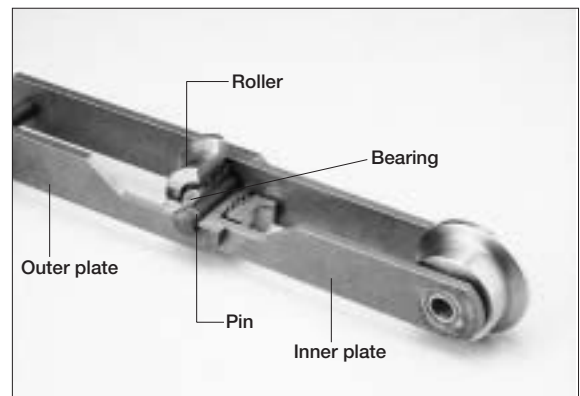

# Classified by Material and Heat Treatment

DK Conveyor Chains are available in a variety of material and heat treatment for improved wear resistance, durability and even to withstand sea water, sludge and various chemicals. The following table lists the symbols, their meanings, features and applications.

## Symbols

※Chains according to specifications are listed on P225.

Environment	Material and heat treatment	Symbol	Material of respective components					Features and applications		
			Plate	Pin	Bushing	Roller				
						R,F	S,M			
Ordinary environment	(Cost-effective) Standard	(J)	Carbon steel	Alloy steel Heat treatment	Alloy steel Heat treatment	Carbon steel	—	For extra-light loads. Rollers are not heat-treated.		
		A				Carbon steel Heat treatment	Carbon steel Heat treatment	Cost-efficient chain for general use.		
	High wear resistance	P				Alloy steel Heat treatment	Alloy steel Heat treatment	Carbon steel Heat treatment	Alloy steel Heat treatment	Chain for vertical conveyor such as bucket elevator; improved wear resistance between pin and bushing.
		C								Chain for running on a horizontal rail while rollers rotate; improved wear resistance at bushings' outer surfaces.
		D								Universal wear resistant chain adopting both C and P.
	Heavy-duty	K				Alloy steel Heat treatment	Alloy steel Heat treatment	Carbon steel Heat treatment	Alloy steel Heat treatment	Chain with tensile strength enhanced by plates of heat-treated alloy steel.
		E								Chain high in durability and wear resistance. Superior quality chain high in tensile strength and wear resistance.
		D3								Carbon steel
	Slightly corrosive environment	With stainless steel parts				D4	Alloy steel Heat treatment	13Cr stainless steel Heat treatment	Alloy steel Heat treatment	Chain higher in tensile strength than D3.
						D1	Carbon steel			Highly effective in a more corrosive environment that D3 cannot tolerate, especially in a location where corrosion is likely to heavily wear pins and cause corrosion fatigue.
D2			Alloy steel Heat treatment	Chain higher in tensile strength than D1.						
D5			Carbon steel	Stainless steel is adopted also for rollers to protect rollers against corrosion defects.						
D6			Alloy steel Heat treatment	Chain higher in tensile strength than D5.						
Corrosive environment			Stainless steel	S4	13Cr stainless steel	13Cr stainless steel Heat treatment	Alloy steel Heat treatment			The same as the following SH except that plates are not heat-treated. This chain can be used when chain tension is small.
	SH			All components are made of heat-treated 13Cr stainless steel, and have excellent strength, wear resistance and corrosion resistance.						
	S5			Plates are made of 18-8 stainless steel, so that the chain can be used in corrosive environment such as exposed to chemical compounds and/or under high temperature.						
	S3	18-8 stainless steel		All components are made of 18-8 stainless steel, to provide exceptionally high corrosion resistance.						

Note: The standard chains are designed to be the most cost efficient. Where greater strength or higher wear resistance is required, heavy-duty chains are recommended.



## Classification by Surface Treatment

There are a variety of selection for heat treatment and specifications for the conveyor chains. Specific treatments can be applied not only to the chain as a whole but to each component separately, such as pins or plates only. Select desired combinations in reference to the following explanation of features and uses.

### Double Guard Coating



The surface is treated with outstanding corrosion resistant coating that approaches the resistance of stainless steel. Double guard coating consists of double layers of two different materials. It exhibits nearly doubled corrosive resistance in the salt water spray test compared to our conventional high guard coating, and can be used in mild alkaline or mild acidic conditions up to pH3.

With its improved corrosive resistance, it can be used in circumstances where high guard or plated coatings cannot be used, and even in some conditions where only stainless steel can be used. (Double guard coating cannot be applied to welded parts.)

### High Guard Coating



High guard coated surface has superb corrosion resistance.

The surface of the chain is finished in non-gloss white highly protective coating. It has excellent resistance to salt corrosion and rusting. This coating protects chains in high temperatures as it can resist heat up to about 250°C. Since high guard coating acts as a sacrificial anode for the chain body, you can expect sufficient corrosion resistance even when the coating has come off to some extent. Also, it can be applied to welded parts.

It is recommended for outdoor use or near the sea in circumstances where performance as high as that of stainless steel is not necessary. In circumstances that require resistance to alkaline and acid, double guard or stainless steel coating is recommended as they have better resistance than high guard.

### Plating



Plating is mostly done with nickel. It is a coating with both appealing exterior and corrosion resistance. By using it with grease lubrication, it exhibits excellent corrosion resistance. You can expect the effect to delay hydrogen brittle destruction when used in circumstances where chains are exposed to sea breeze or acidic sprays. (Double guard coating cannot be applied to welded parts.)

### Symbols



Resistant against corrosive gas (by CASS test)



Resistant against rain, moisture or sea water



Resistant against alkali liquid



Resistant against acid liquid



Allowable ambient temperature

# Chain Specifications

## 1. Standard Conveyor Chain (for Metric and Inch series)

Chain No.	Roller type				Tensile strength kN (kgf)								
	Large roller Flange roller R	Medium roller M	Small roller S	Bearing assembled roller Large roller with large clearance BF Flange roller with large clearance UR	Standard A,J	Wear resistant C,D,P	Heavy-duty K,E	With stainless steel parts		Stainless steel			
								D1,D3,D5	D2,D4,D6	S4	SH	S3	S5
	F												
DK 03075 DK 03100 DK 03125 DK 03150	○	×	○	○	34.3 (3,500)		69.6 (7,100)	34.3 (3,500)	69.6 (7,100)	29.4 (3,000)	49.0 (5,000)	31.3 (3,200)	33.3 (3,400)
DK 07075 DK 07100 DK 07125 DK 07150	○	×	○	○	68.6 (7,000)		132 (13,500)	68.6 (7,000)	132 (13,500)	68.6 (7,000)	103 (10,500)	63.7 (6,500)	81.3 (8,300)
DK 09100 DK 09125 DK 09150	○	○	○	×	88.2 (9,000)		156 (16,000)	88.2 (9,000)	156 (16,000)	83.3 (8,500)	132 (13,500)	73.5 (7,500)	87.2 (8,900)
DK 11100 DK 11125 DK 11150 DK 11200	○	○	○	○	112 (11,500)		225 (23,000)	112 (11,500)	225 (23,000)	102 (10,500)	166 (17,000)	102 (10,500)	112 (11,500)
DK 13150 DK 13200	○	○	○	○	127 (13,000)		240 (24,500)	132 (13,500)	240 (24,500)	122 (12,500)	196 (20,000)	127 (13,000)	127 (13,000)
DK 19200 DK 19250 DK 19300	○	○	○	○	186 (19,000)		279 (28,500)	186 (19,000)	279 (28,500)	171 (17,500)	274 (28,000)	132 (13,500)	176 (18,000)
DK 25200 DK 25250 DK 25300	○	○	○	○	245 (25,000)		392 (40,000)	245 (25,000)	392 (40,000)	205 (21,000)	323 (33,000)	186 (19,000)	225 (23,000)
DK 32200 DK 32250 DK 32300 DK 32450	○	○	○	○	313 (32,000)		500 (51,000)	313 (32,000)	500 (51,000)	294 (30,000)	460 (47,000)	254 (26,000)	313 (32,000)
DK 50250 DK 50300 DK 50450 DK 50600	○	○	○	○	490 (50,000)		686 (70,000)	490 (50,000)	686 (70,000)	490 (50,000)	686 (70,000)	333 (34,000)	519 (53,000)
DK 65300 DK 65450	○	○	○	×	637 (65,000)		882 (90,000)	637 (65,000)	882 (90,000)	568 (58,000)	833 (85,000)	402 (41,000)	588 (60,000)
DK 05101	○	×	×	×	53.9 (5,500)		98.0 (10,000)	53.9 (5,500)	98.0 (10,000)	49.0 (5,000)	78.4 (8,000)	49.0 (5,000)	52.9 (5,400)
DK 08066 DK 08101	×	○	○	×	78.4 (8,000)		142 (14,500)	78.5 (8,000)	142 (14,500)	68.6 (7,000)	112 (11,500)	68.6 (7,000)	73.4 (7,500)
DK 09101	○	○	○	×	88.2 (9,000)		156 (16,000)	88.2 (9,000)	156 (16,000)	83.3 (8,500)	127 (13,000)	83.3 (8,500)	88.2 (9,000)
DK 11152	○	○	○	○	112 (11,500)		171 (17,500)	112 (11,500)	171 (17,500)	102 (10,500)	171 (17,500)	83.3 (8,500)	117 (12,000)
DK 13101	○	○	○	×	127 (13,000)		240 (24,500)	127 (13,000)	240 (24,500)	122 (12,500)	196 (20,000)	127 (13,000)	127 (13,000)
DK 19152	○	○	○	○	186 (19,000)		279 (28,500)	186 (19,000)	279 (28,500)	171 (17,500)	274 (28,000)	132 (13,000)	176 (18,000)
DK 25152	○	○	○	○	245 (25,000)		392 (40,000)	245 (25,000)	392 (40,000)	205 (21,000)	323 (33,000)	186 (19,000)	225 (23,000)

○ : Standard product    × : Custom-made

## Dimensional Drawings: DK 03075, DK 03100, DK 03125, DK 03150 (for Metric series)

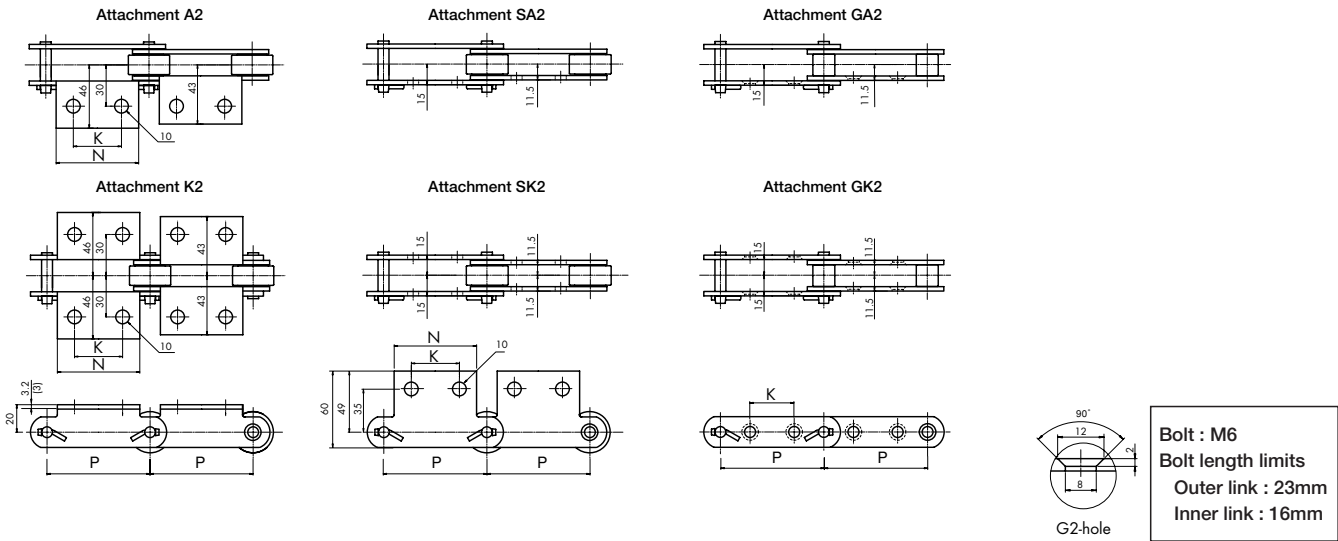
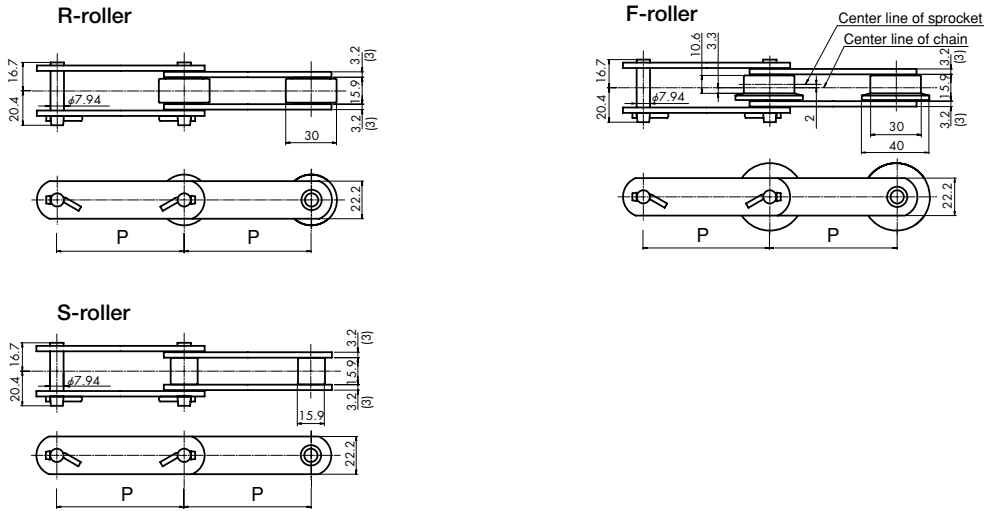

Chain No.		Avg. tensile strength kN (kgf)		Pitch	Standard attachments											
Chain size	Roller type	Normal A,J	Heavy duty K,E	P	A1 · K1		A2 · K2		A3 · K3		SA2 · SK2		GA2 · GK2		G4	
					N	N	N	K	N	K	N	K	K	Y	B	
DK 03075	R,F,S	34.3 (3,500)	69.6 (7,100)	75	—	60	35	—	—	60	35	32	—	—	—	
DK 03100	R,F,S			100	—	65	40	—	—	65	40	40	—	—	—	
DK 03125	R,F,S			125	—	75	50	—	—	—	—	50	—	—	—	
DK 03150	R,F,S			150	—	85	60	—	—	—	—	60	—	—	—	

Chain No.		Combination of standard attachments and rollers						Approx. weight kg/m				Attachment weight (kg)				
Chain size	Roller type	A1	A2	A3	SA2	GA2	G4	R-roller	F-roller	S-roller	M-roller	A2	A3	K2	K3	G4
		K1	K2	K3	SK2	GK2						SA2		SK2		
DK 03075	R,F,S	—	R,F,S	—	R,S	S	—	2.6	2.8	1.8	—	0.05	—	0.10	—	—
DK 03100	R,F,S	—	R,F,S	—	R,S	R,F,S	—	2.2	2.4	1.6	—	0.06	—	0.12	—	—
DK 03125	R,F,S	—	R,F,S	—	—	R,S	—	2.0	2.1	1.5	—	0.07	—	0.14	—	—
DK 03150	R,F,S	—	R,F,S	—	—	R,F,S	—	1.8	1.8	1.4	—	0.08	—	0.16	—	—

Note: 1. Values in ( ) for the plate thickness are for the stainless steel chains. Values for plate thickness without ( ) apply to all types.  
 2. The dimensions of the normal and heavy duty chains are the same, but heavy duty chains are made of high-strength and structural steel, and are suitable when higher safety rate, strength or wear resistance is required.  
 3. With Attachment GA2 and GK2, check the bolt length limits shown above.

## Dimensional Drawings: DK 07075, DK 07100, DK 07125 and DK 07150 (for Metric series)

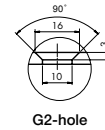
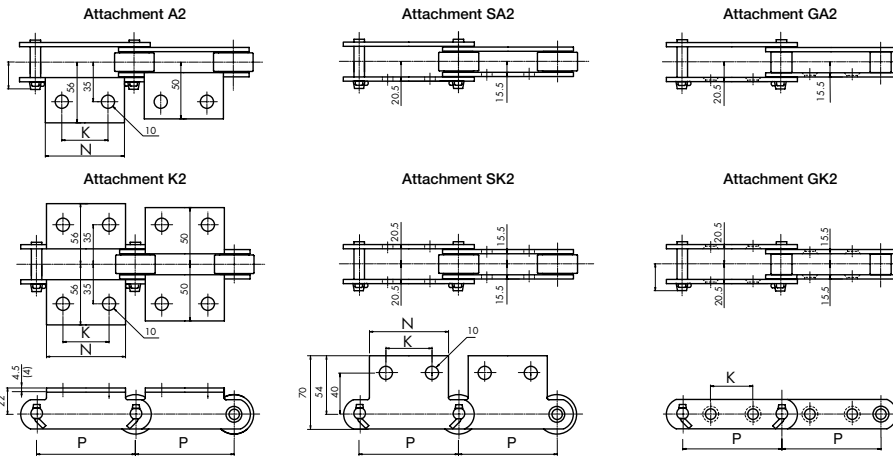
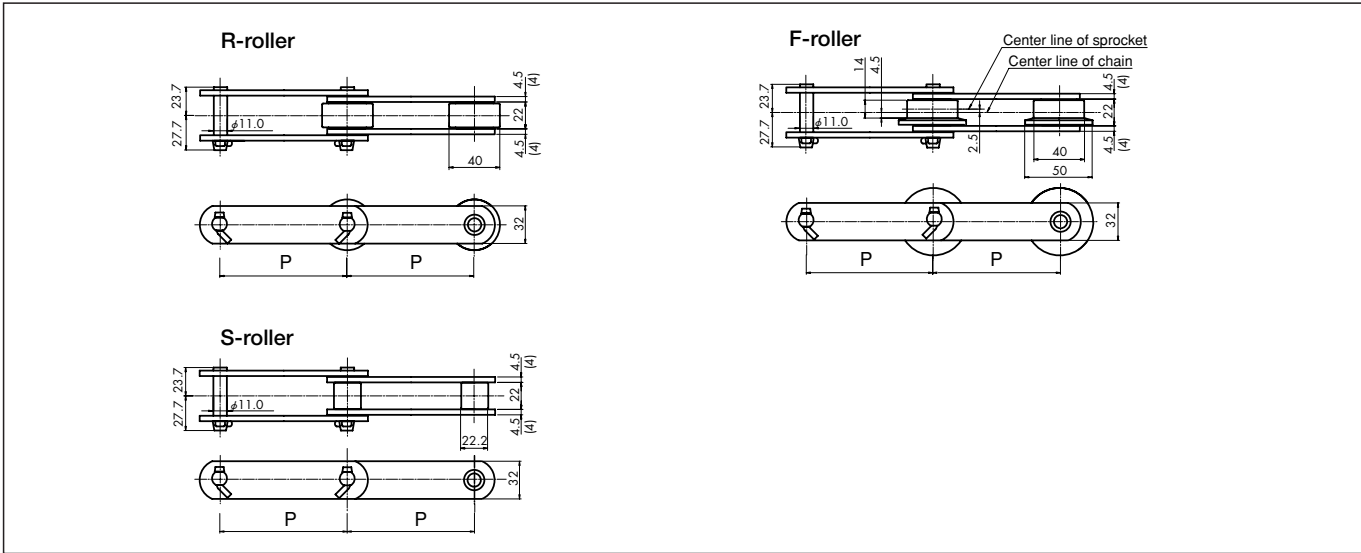

**Bolt: M8**  
**Bolt length limits**  
**Outer link: 35mm**  
**Inner link: 25mm**

Chain No.		Avg. tensile strength kN (kgf)		Pitch	Standard attachments												
Chain size	Roller type	Normal A,J	Heavy duty K,E	P	A1 · K1		A2 · K2		A3 · K3		SA2 · SK2		GA2 · GK2		G4		
					K	N	K	N	K	N	K	K	K	K	Y	B	
<b>DK 07075</b>	<b>R,F,S</b>	68.6 (7,000)	132 (13,500)	75	—	60	35	—	—	—	—	—	—	—	—	—	
<b>DK 07100</b>	<b>R,F,S</b>			100	—	65	40	—	—	65	40	40(34)	—	—	—	—	—
<b>DK 07125</b>	<b>R,F,S</b>			125	—	75	50	—	—	—	—	50	—	—	—	—	—
<b>DK 07150</b>	<b>R,F,S</b>			150	—	85	60	—	—	85	60	60	—	—	—	—	—

Chain No.		Combination of standard attachments and rollers					Approx. weight kg/m				Attachment weight (kg)					
Chain size	Roller type	A1 K1	A2 K2	A3 K3	SA2 SK2	GA2 GK2	G4	R-roller	F-roller	S-roller	M-roller	A2 SA2	A3	K2 SK2	K3	G4
<b>DK 07075</b>	<b>R,F,S</b>	—	R,F,S	—	—	—	—	5.6	5.9	3.8	—	0.09	—	0.18	—	—
<b>DK 07100</b>	<b>R,F,S</b>	—	R,F,S	—	R,S	R,F,S	—	5.0	5.2	3.6	—	0.10	—	0.20	—	—
<b>DK 07125</b>	<b>R,F,S</b>	—	R,F,S	—	—	R,F,S	—	4.6	4.8	3.5	—	0.12	—	0.24	—	—
<b>DK 07150</b>	<b>R,F,S</b>	—	R,F,S	—	R,S	R,F,S	—	4.2	4.4	3.4	—	0.13	—	0.26	—	—

- Note:** 1. Values in ( ) for the plate thickness are for the stainless steel chains. Values for plate thickness without ( ) apply to all types.  
 2. The dimensions of the normal and heavy duty chains are the same, but heavy duty chains are made of high-strength and structural steel, and are suitable when higher safety rate, strength or wear resistance is required.  
 3. The K values in ( ) for Attachment GA2 and GK2 are for Roller F.  
 4. With Attachment GA2 and GK2, check the bolt length limits shown above.

## Dimensional Drawings: DK 09100, DK 09125, DK 09150 and DK 09200 (for Metric series)

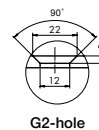
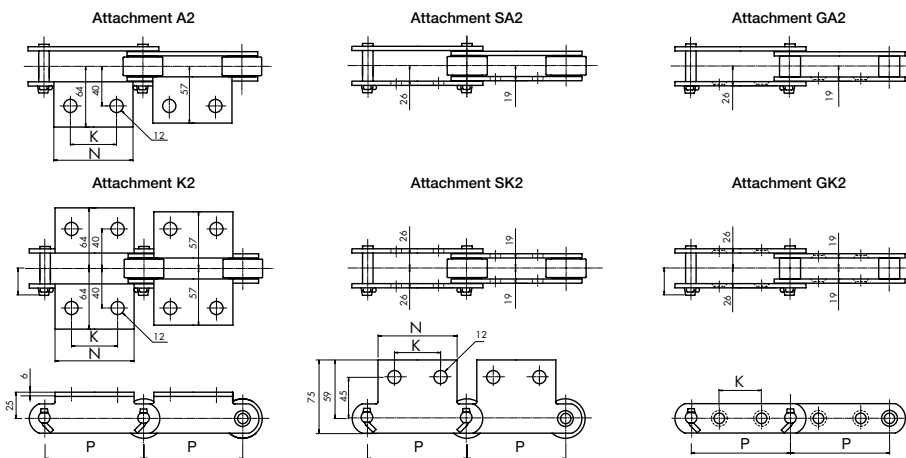
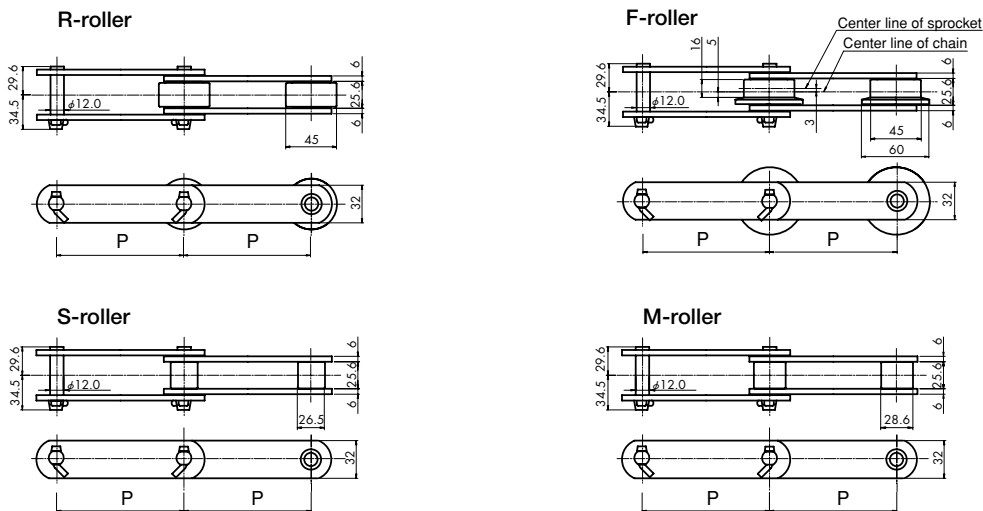

**Bolt: M10**  
**Bolt length limits**  
 Outer link: 43mm  
 Inner link: 30mm

Chain No.		Avg. tensile strength kN (kgf)		Pitch	Standard attachments												
Chain size	Roller type	Normal A,J	Heavy duty K,E	P	A1 · K1		A2 · K2		A3 · K3		SA2 · SK2		GA2 · GK2		G4		
					N	K	N	K	N	K	N	K	K	Y	B		
DK 09100	R,F,S,M	88.2 (9,000)	156 (16,000)	100	—	70	40	—	—	—	—	—	35	—	—	—	
DK 09125	R,F,S,M			125	—	80	50	—	—	—	—	—	—	45	—	—	—
DK 09150	R,F,S,M			150	—	90	60	—	—	90	60	60	—	—	—	—	—
DK 09200	R,F,S,M			200	—	110	80	—	—	—	—	—	—	80	—	—	—

Chain No.		Combination of standard attachments and rollers						Approx. weight kg/m				Attachment weight (kg)				
Chain size	Roller type	A1	A2	A3	SA2	GA2	G4	R-roller	F-roller	S-roller	M-roller	A2	A3	K2	K3	G4
		K1	K2	K3	SK2	GK2						SA2	SK2	K3	G4	
DK 09100	R,F,S,M	—	R,F,S,M	—	—	S,M	—	7.1	7.4	5.1	5.7	0.16	—	0.32	—	—
DK 09125	R,F,S,M	—	R,F,S,M	—	—	R,F,S,M	—	6.4	6.6	4.8	5.4	0.18	—	0.36	—	—
DK 09150	R,F,S,M	—	R,F,S,M	—	R,S,M	R,F,S,M	—	5.8	6.0	4.6	5.1	0.20	—	0.40	—	—
DK 09200	R,F,S,M	—	R,F,S,M	—	—	R,F,S,M	—	5.1	5.3	4.2	4.3	0.22	—	0.44	—	—

Note: 1. The dimensions of the normal and heavy duty chains are the same, but heavy duty chains are made of high-strength and structural steel, and are suitable when higher safety rate, strength or wear resistance is required.  
 2. With Attachment GA2 and GK2, check the bolt length limits shown above.

## Dimensional Drawings: DK 1100, DK 1125, DK 1150 and DK 1200 (for Metric series)

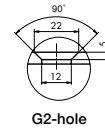
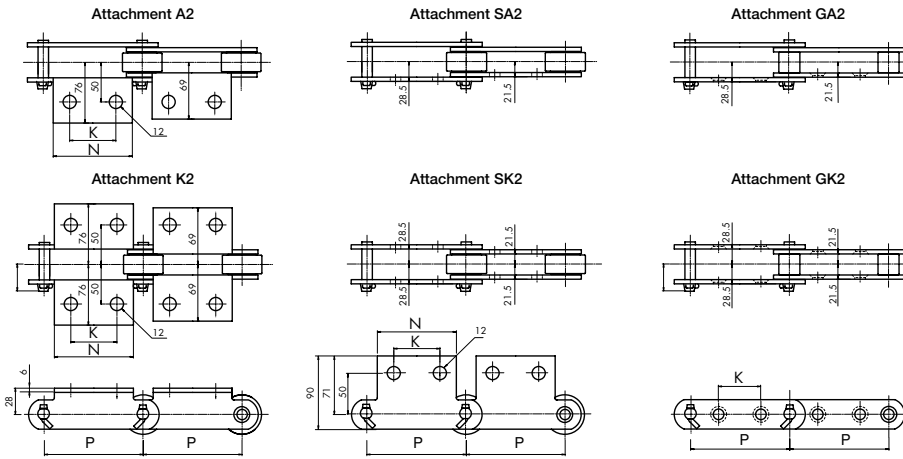
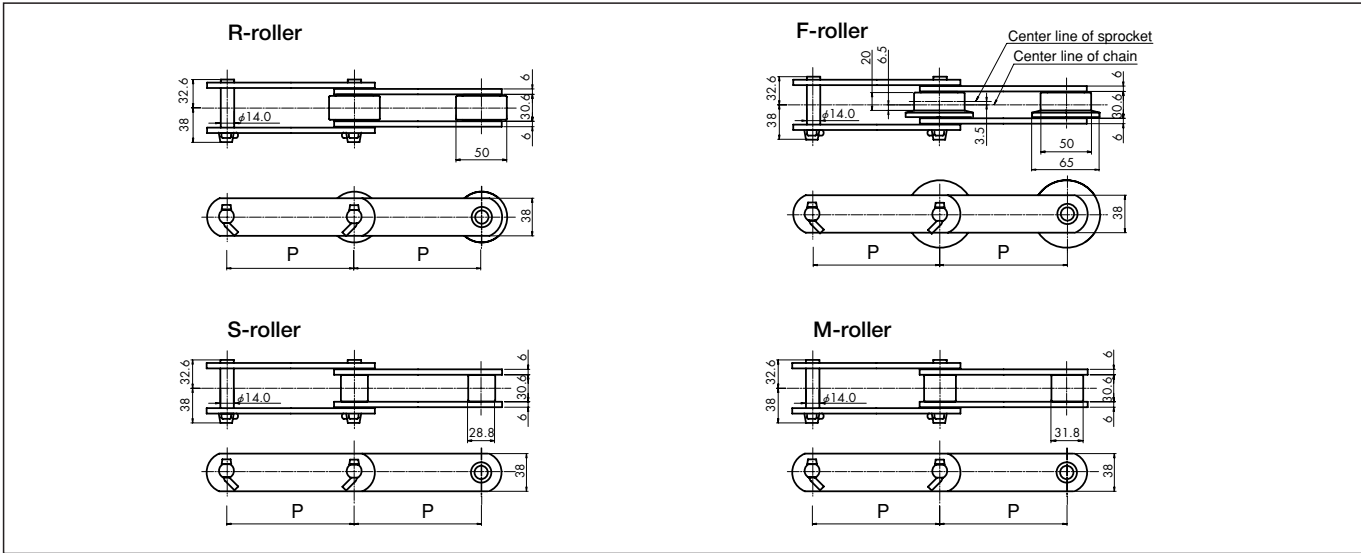

**Bolt: M10**  
**Bolt length limits**  
 Outer link: 49mm  
 Inner link: 35mm

Chain No.		Avg. tensile strength kN (kgf)		Pitch	Standard attachments													
Chain size	Roller type	Normal A,J	Heavy duty K,E	P	A1 · K1		A2 · K2		A3 · K3		SA2 · SK2		GA2 · GK2		G4			
					N	N	K	N	K	N	K	K	K	K	Y	B		
DK 11100	R,F,S,M	112 (11,500)	225 (23,000)	100	—	70	40	—	—	—	—	70	40	35	—	—		
DK 11125	R,F,S,M			125	—	80	50	—	—	—	—	—	35	—	—	—	—	
DK 11150	R,F,S,M			150	—	90	60	—	—	—	—	90	60	60	—	—	—	—
DK 11200	R,F,S,M			200	—	110	80	—	—	—	—	—	—	80	—	—	—	—

Chain No.		Combination of standard attachments and rollers						Approx. weight kg/m				Attachment weight (kg)				
Chain size	Roller type	A1 K1	A2 K2	A3 K3	SA2 SK2	GA2 GK2	G4	R-roller	F-roller	S-roller	M-roller	A2 SA2	A3	K2 SK2	K3	G4
DK 11100	R,F,S,M	—	R,F,S,M	—	R,S,M	S,M	—	9.6	10.1	6.6	7.1	0.19	—	0.39	—	—
DK 11125	R,F,S,M	—	R,F,S,M	—	—	R,F,S,M	—	8.5	8.9	6.1	6.6	0.21	—	0.42	—	—
DK 11150	R,F,S,M	—	R,F,S,M	—	R,S,M	R,F,S,M	—	7.6	7.9	5.7	6.1	0.24	—	0.48	—	—
DK 11200	R,F,S,M	—	R,F,S,M	—	—	R,F,S,M	—	6.5	6.8	5.2	5.5	0.29	—	0.58	—	—

Note: 1. The dimensions of the normal and heavy duty chains are the same, but heavy duty chains are made of high-strength and structural steel, and are suitable when higher safety rate, strength or wear resistance is required.  
 2. With Attachment GA2 and GK2, check the bolt length limits shown above.

## Dimensional Drawings: DK 13150 and DK 13200 (for Metric series)

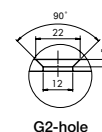
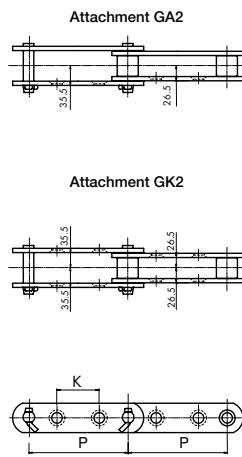
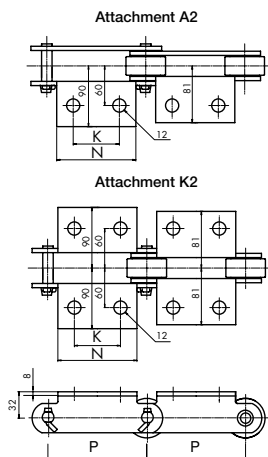
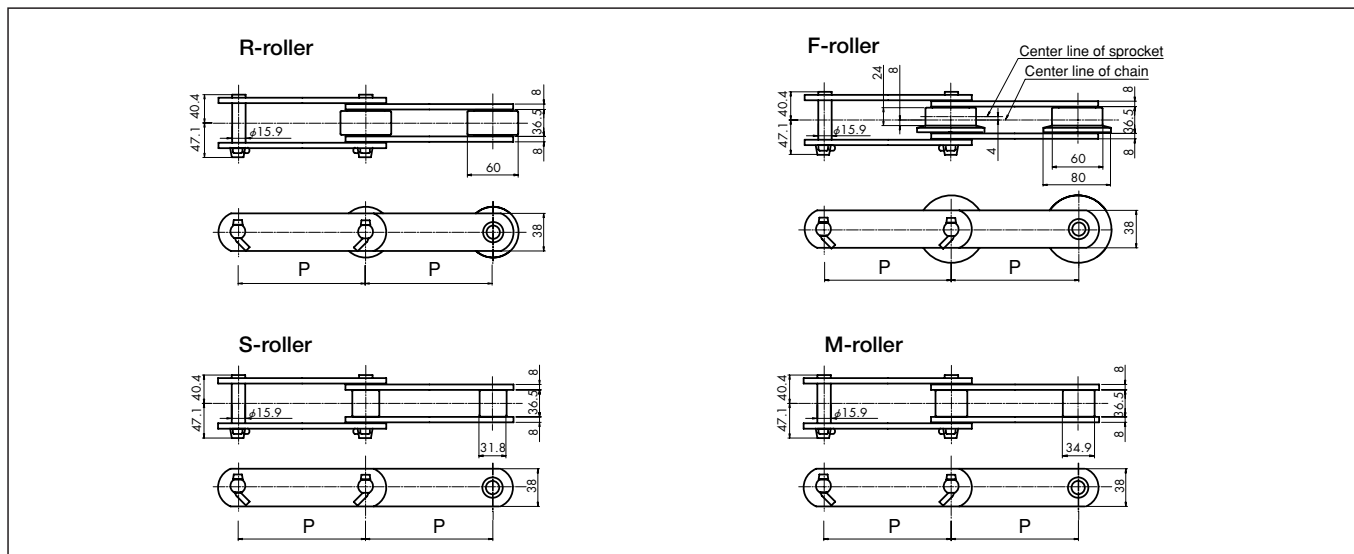

**Bolt: M10**  
**Bolt length limits**  
 Outer link: 60mm  
 Inner link: 40mm

Chain No.		Avg. tensile strength kN (kgf)		Pitch	Standard attachments											
Chain size	Roller type	Normal A,J	Heavy duty K,E	P	A1 · K1		A2 · K2		A3 · K3		SA2 · SK2		GA2 · GK2		G4	
					K	N	K	K	N	K	K	K	Y	B		
<b>DK 13150</b>	<b>R,F,S,M</b>	127	240	150	—	90	60	—	—	—	—	45	—	—	—	—
<b>DK 13200</b>	<b>R,F,S,M</b>	(13,000)	(24,500)	200	—	110	80	—	—	—	—	80	—	—	—	—

Chain No.		Combination of standard attachments and rollers						Approx. weight kg/m				Attachment weight (kg)				
Chain size	Roller type	A1	A2	A3	SA2	GA2	G4	R-roller	F-roller	S-roller	M-roller	A2	A3	K2	K3	G4
		K1	K2	K3	SK2	GK2										
<b>DK 13150</b>	<b>R,F,S,M</b>	—	R,F,S,M	—	—	R,F,S,M	—	10.9	11.6	7.6	8.1	0.39	—	0.78	—	—
<b>DK 13200</b>	<b>R,F,S,M</b>	—	R,F,S,M	—	—	R,F,S,M	—	9.3	9.8	6.9	7.2	0.48	—	0.96	—	—

Note: 1. The dimensions of the normal and heavy duty chains are the same, but heavy duty chains are made of high-strength and structural steel, and are suitable when higher safety rate, strength or wear resistance is required.  
 2. With Attachment GA2 and GK2, check the bolt length limits shown above.



# Dimensional Drawings: DK 19200, DK 19250 and DK 19300 (for Metric series)

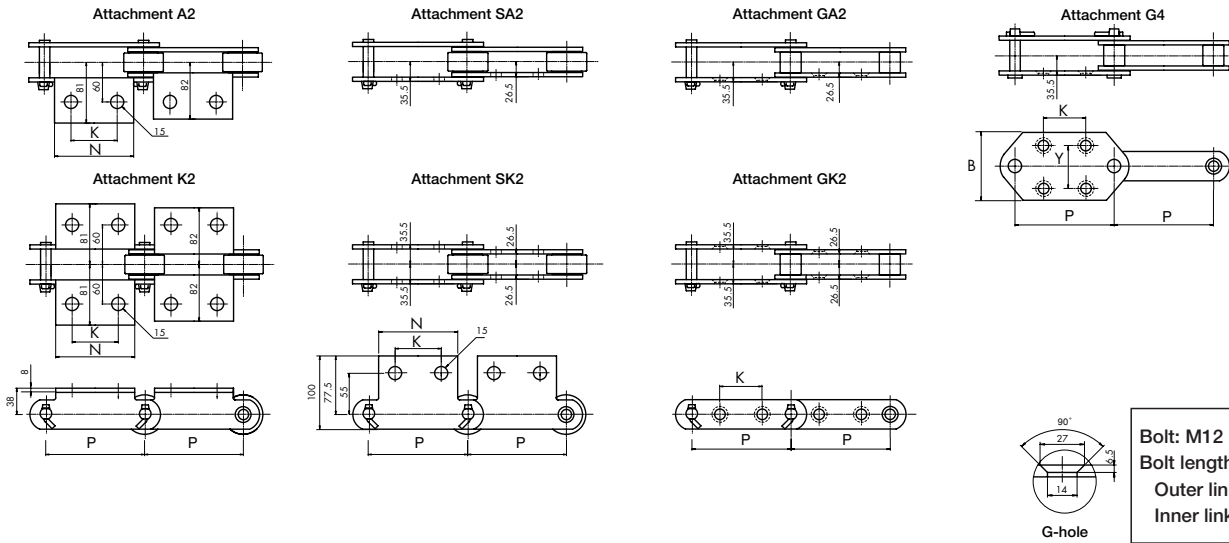
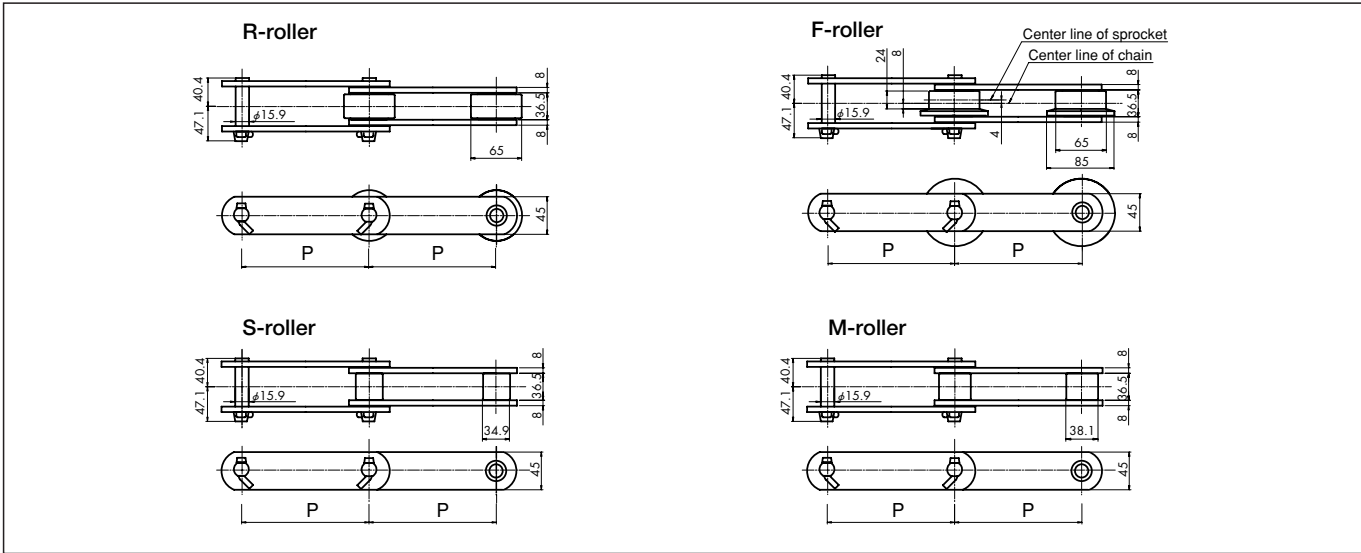

**Bolt: M12**  
**Bolt length limits**  
**Outer link: 63mm**  
**Inner link: 45mm**

Chain No.		Avg. tensile strength kN (kgf)		Pitch	Standard attachments											
Chain size	Roller type	Normal A,J	Heavy duty K,E	P	A1 · K1		A2 · K2		A3 · K3		SA2 · SK2		GA2 · GK2		G4	
					N	K	N	K	N	K	N	K	K	Y	B	
DK 19200	R,F,S,M	186 (19,000)	279 (28,500)	200	—	120	80	—	—	120	80	80	100	80	125	
DK 19250	R,F,S,M			250	—	170	125	—	—	170	125	125	100	80	125	
DK 19300	R,F,S,M			300	—	220	180	—	—	—	—	150	—	—	—	

Chain No.		Combination of standard attachments and rollers						Approx. weight kg/m				Attachment weight (kg)				
Chain size	Roller type	A1 K1	A2 K2	A3 K3	SA2 SK2	GA2 GK2	G4	R-roller	F-roller	S-roller	M-roller	A2 SA2	A3	K2 SK2	K3	G4
DK 19200	R,F,S,M	—	R,F,S,M	—	R,S,M	R,F,S,M	R,F,S,M	11.5	12.1	8.4	8.6	0.49	—	0.98	—	0.95
DK 19250	R,F,S,M	—	R,F,S,M	—	R,S,M	R,F,S,M	R,F,S,M	10.3	10.8	7.9	8.1	0.69	—	1.38	—	1.20
DK 19300	R,F,S,M	—	R,F,S,M	—	—	R,F,S,M	—	9.5	10.0	7.5	7.8	0.89	—	1.78	—	—

Note: 1. The dimensions of the normal and heavy duty chains are the same, but heavy duty chains are made of high-strength and structural steel, and are suitable when higher safety rate, strength or wear resistance is required.  
 2. With Attachment GA2 and GK2, check the bolt length limits shown above.

DK Conveyor Chains  
 Standard  
 Conveyor Chain

## Dimensional Drawings: DK 25200, DK 25250 and DK 25300 (for Metric series)

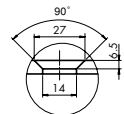
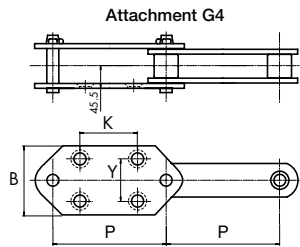
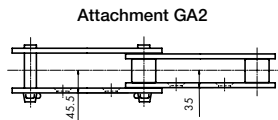
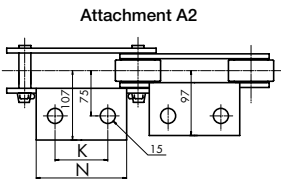
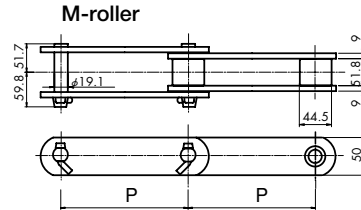
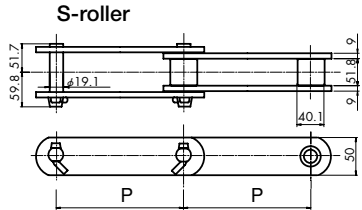
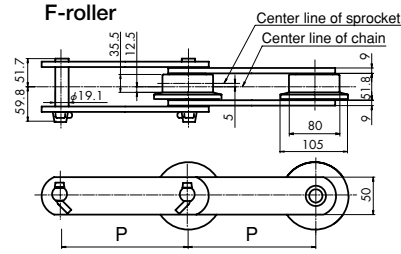
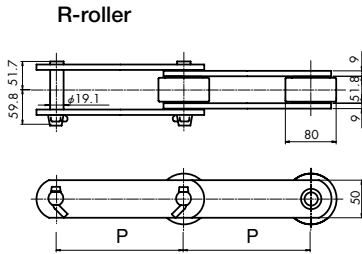

G4-hole  
Bolt: M12

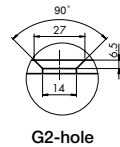
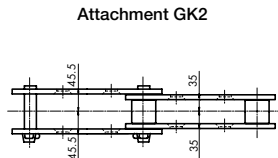
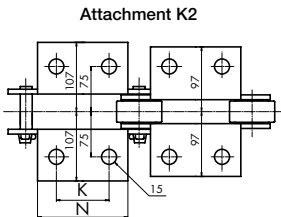

Bolt: M12  
Bolt length limits  
Outer link: 80mm  
Inner link: 60mm

G2-hole

Chain No.		Avg. tensile strength kN (kgf)		Pitch	Standard attachments											
Chain size	Roller type	Normal A,J	Heavy duty K,E	P	A1 · K1		A2 · K2		A3 · K3		SA2 · SK2		GA2 · GK2		G4	
					K	N	K	N	K	N	K	K	K	Y	B	
DK 25200	R,F,S,M	245 (25,000)	392 (40,000)	200	—	120	80	—	—	—	—	70	100	80	125	
DK 25250	R,F,S,M			250	—	170	125	—	—	—	—	110	140	80	125	
DK 25300	R,F,S,M			300	—	220	180	—	—	—	—	150	—	—	—	

Chain No.		Combination of standard attachments and rollers						Approx. weight kg/m				Attachment weight (kg)				
Chain size	Roller type	A1 K1	A2 K2	A3 K3	SA2 SK2	GA2 GK2	G4	R-roller	F-roller	S-roller	M-roller	A2	A3	K2	K3	G4
												—	—	—	—	—
DK 25200	R,F,S,M	—	R,F,S,M	—	—	R,F,S,M	R,F,S,M	18.2	19.5	11.4	11.9	0.63	—	1.26	—	1.05
DK 25250	R,F,S,M	—	R,F,S,M	—	—	R,F,S,M	R,F,S,M	15.9	17.0	10.6	11.0	0.90	—	1.80	—	1.32
DK 25300	R,F,S,M	—	R,F,S,M	—	—	R,F,S,M	—	14.5	15.3	9.9	10.3	1.16	—	2.32	—	—

Note: 1. The dimensions of the normal and heavy duty chains are the same, but heavy duty chains are made of high-strength and structural steel, and are suitable when higher safety rate, strength or wear resistance is required.  
2. With Attachment GA2 and GK2, check the bolt length limits shown above.

# Dimensional Drawings: DK 32200, DK 32250, DK 32300 and DK 32450 (for Metric series)

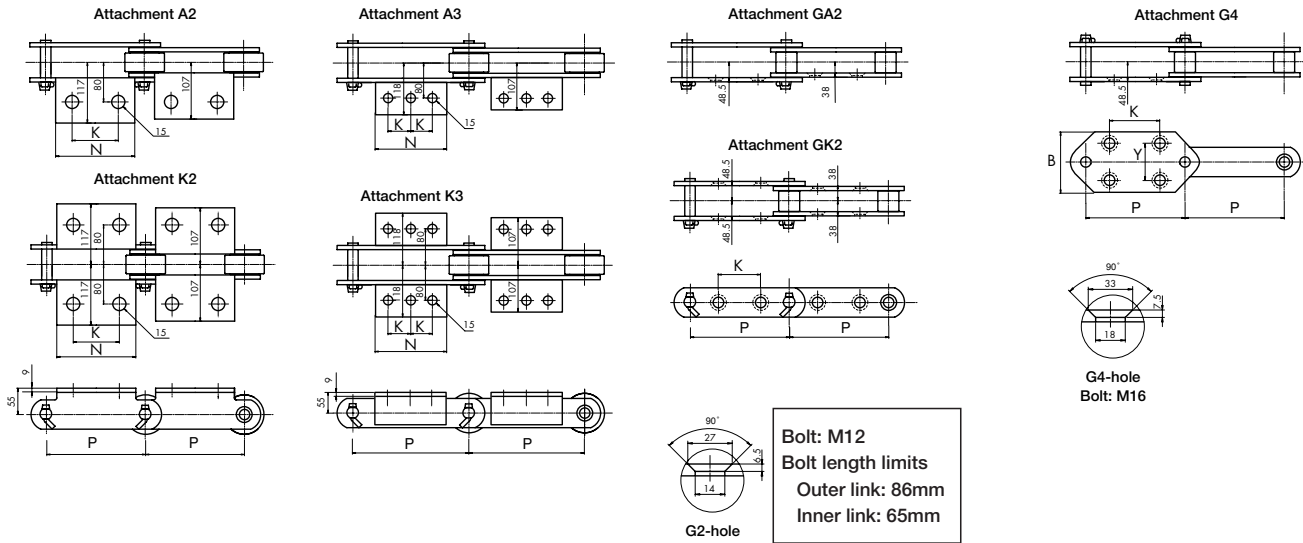
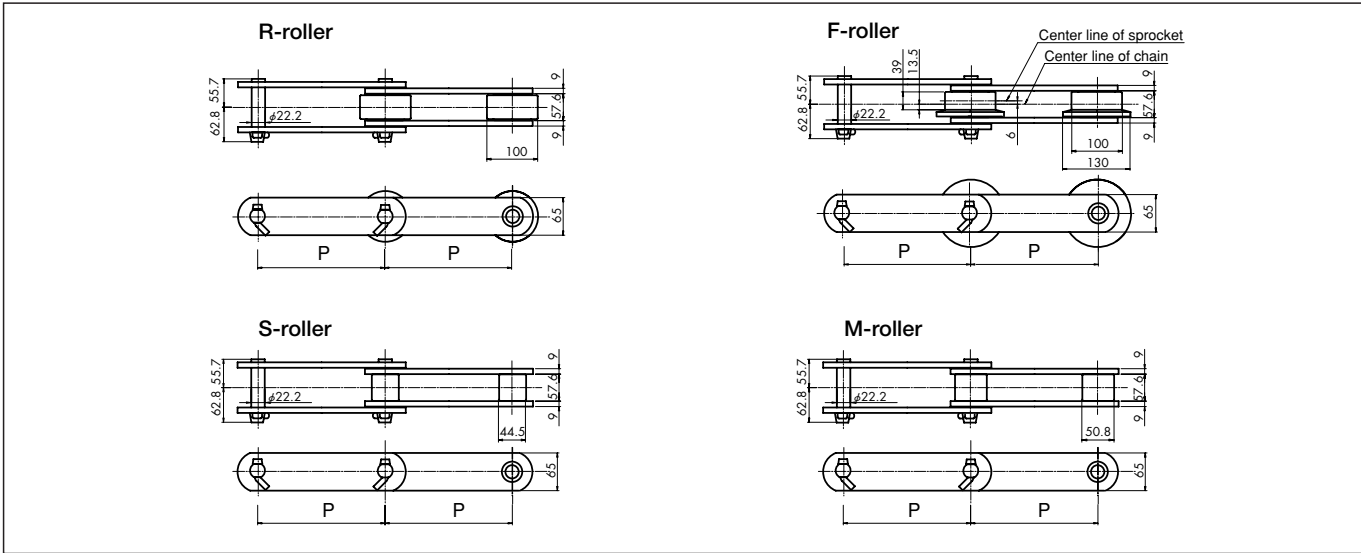

**Bolt: M12**  
**Bolt length limits**  
 Outer link: 86mm  
 Inner link: 65mm

Chain No.		Avg. tensile strength kN (kgf)		Pitch	Standard attachments													
Chain size	Roller type	Normal A,J	Heavy duty K,E	P	A1 · K1		A2 · K2		A3 · K3		SA2 · SK2		GA2 · GK2		G4			
					N	N	N	K	N	K	N	K	K	Y	B			
DK 32200	R,F,S,M	313 (32,000)	500 (51,000)	200	—	120	80	—	—	—	—	—	70(40)	100	80	125		
DK 32250	R,F,S,M			250	—	170	125	—	—	—	—	—	—	110(90)	140	100	150	
DK 32300	R,F,S,M			300	—	220	180	—	—	—	—	—	—	—	140	170	100	150
DK 32450	R,F,S,M			450	—	330	280	330	140	—	—	—	—	—	220	—	—	—

Chain No.		Combination of standard attachments and rollers					Approx. weight kg/m				Attachment weight (kg)					
Chain size	Roller type	A1 K1	A2 K2	A3 K3	SA2 SK2	GA2 GK2	G4	R-roller	F-roller	S-roller	M-roller	A2	A3	K2	K3	G4
DK 32200	R,F,S,M	—	R,F,S,M	—	—	R,F,S,M	R,F,S,M	28.2	30.2	15.5	16.4	0.72	—	1.44	—	0.91
DK 32250	R,F,S,M	—	R,F,S,M	—	—	R,F,S,M	R,F,S,M	24.6	26.2	14.4	15.2	1.01	—	2.02	—	1.48
DK 32300	R,F,S,M	—	R,F,S,M	—	—	R,F,S,M	R,F,S,M	22.0	23.4	13.6	14.2	1.31	—	2.62	—	1.78
DK 32450	R,F,S,M	—	R,F,S,M	R,F,S,M	—	R,F,S,M	—	17.8	18.7	11.9	12.1	—	1.97	—	3.97	—

Note: 1. The dimensions of the normal and heavy duty chains are the same, but heavy duty chains are made of high-strength and structural steel, and are suitable when higher safety rate, strength or wear resistance is required.  
 2. K values in ( ) for Attachment GA2 and GK2 are for Roller F.  
 3. With Attachment GA2 and GK2, check the bolt length limits shown above.  
 4. Attachment A3 and K3 are angle welding attachments.

## Dimensional Drawings: DK 50250, DK 50300, DK 50450 and DK 50600 (for Metric series)

DK Conveyor Chains  
Standard Conveyor Chain

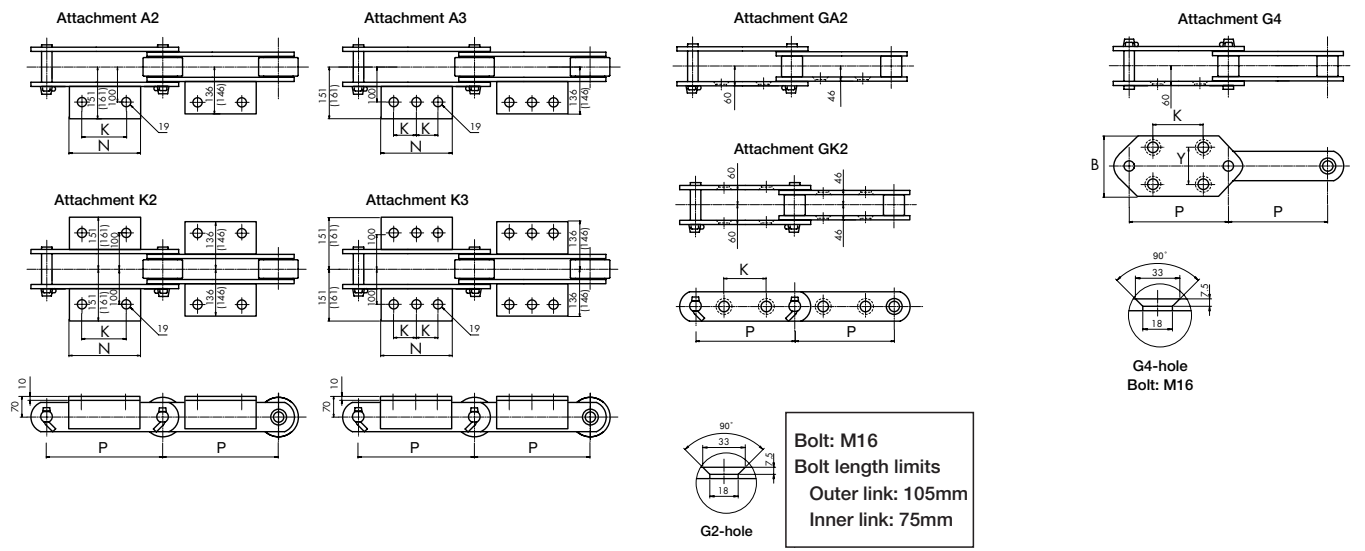
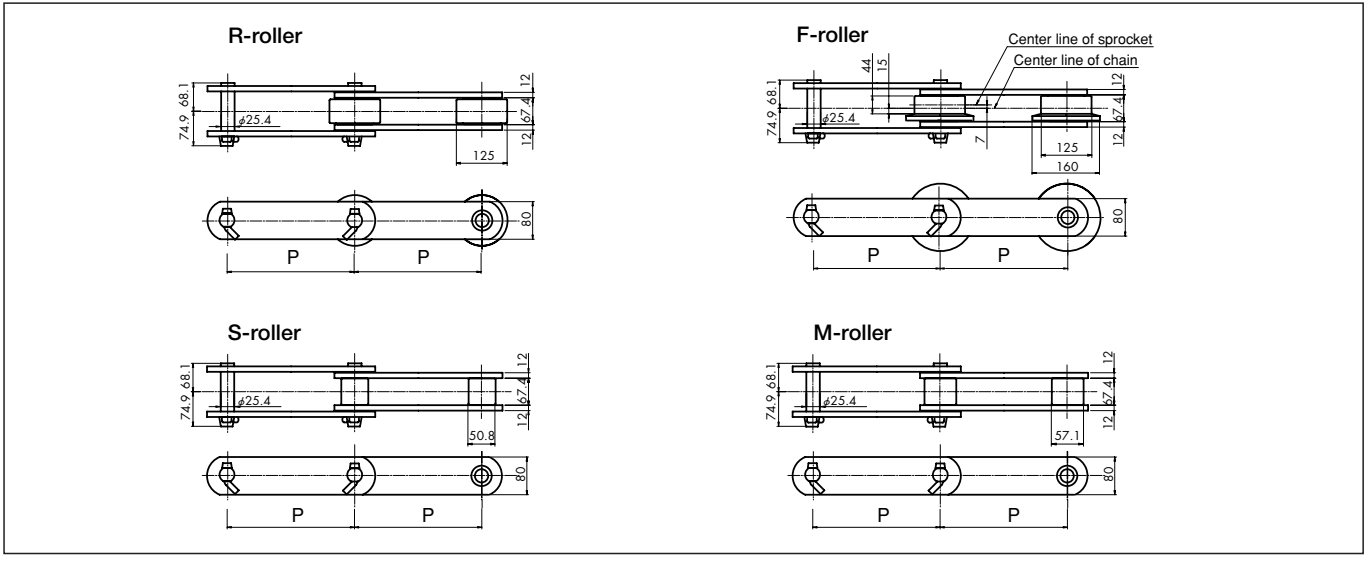

Chain No.		Avg. tensile strength kN (kgf)		Pitch	Standard attachments								
Chain size	Roller type	Normal A,J	Heavy duty K,E	P	A1 · K1 N	A2 · K2 N	A3 · K3 N	SA2 · SK2 N	GA2 · GK2 K	G4 K Y B			
DK 50250	R,F,S,M	490 (50,000)	686 (70,000)	250	—	170	125	—	—	90 (55)	140	100	150
DK 50300	R,F,S,M			300	—	220	180	—	—	140(105)	170	100	150
DK 50450	R,F,S,M			450	—	—	330	140	—	220	—	—	—
DK 50600	R,F,S,M			600	—	—	410	180	—	300	—	—	—

Chain No.		Combination of standard attachments and rollers						Approx. weight kg/m				Attachment weight (kg)				
Chain size	Roller type	A1 K1	A2 K2	A3 K3	SA2 SK2	GA2 GK2	G4	R-roller	F-roller	S-roller	M-roller	A2	A3	K2	K3	G4
DK 50250	R,F,S,M	—	R,F,S,M	—	—	R,F,S,M	R,F,S,M	42.7	45.8	24.1	25.2	2.26	—	4.52	—	1.74
DK 50300	R,F,S,M	—	R,F,S,M	—	—	R,F,S,M	R,F,S,M	38.0	40.4	22.4	23.3	2.93	—	5.86	—	2.07
DK 50450	R,F,S,M	—	—	R,F,S,M	—	R,F,S,M	—	30.3	31.9	19.8	20.2	—	4.39	—	8.78	—
DK 50600	R,F,S,M	—	—	R,F,S,M	—	R,F,S,M	—	26.7	28.0	19.0	19.4	—	5.45	—	10.90	—

Note: 1. The dimensions of the normal and heavy duty chains are the same, but heavy duty chains are made of high-strength and structural steel, and are suitable when higher safety rate, strength or wear resistance is required.  
 2. K values in ( ) for Attachment GA2 and GK2 are for Roller F.  
 3. With Attachment GA2 and GK2, check the bolt length limits shown above.  
 4. Attachment A3 and K3 are angle welding attachments.

# Dimensional Drawings: DK 65300 and DK 65450 (for Metric series)

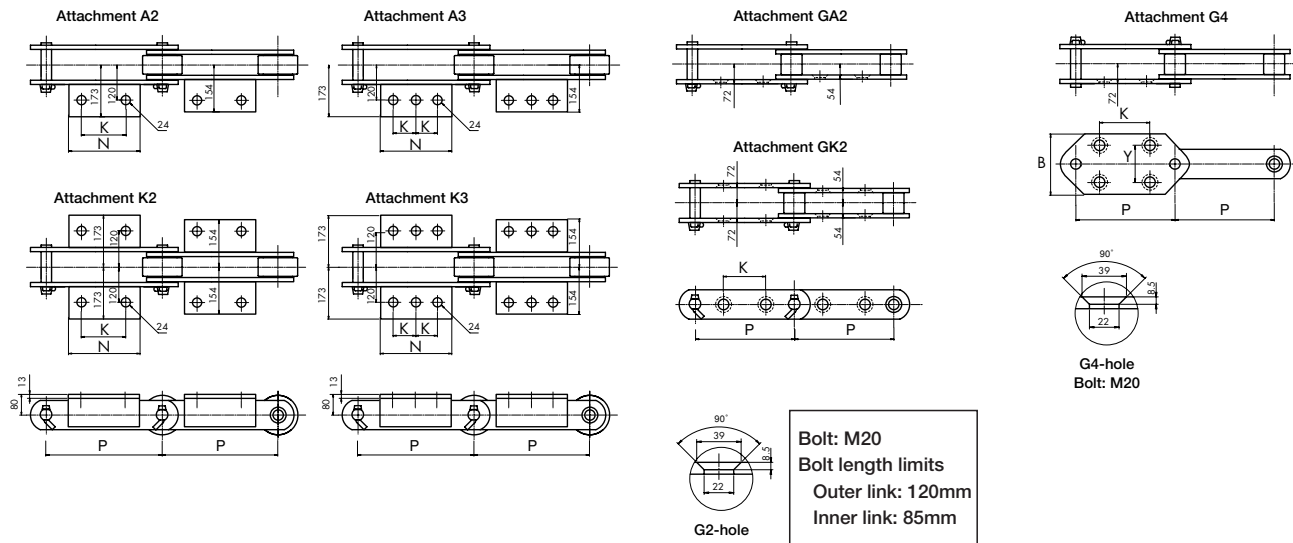
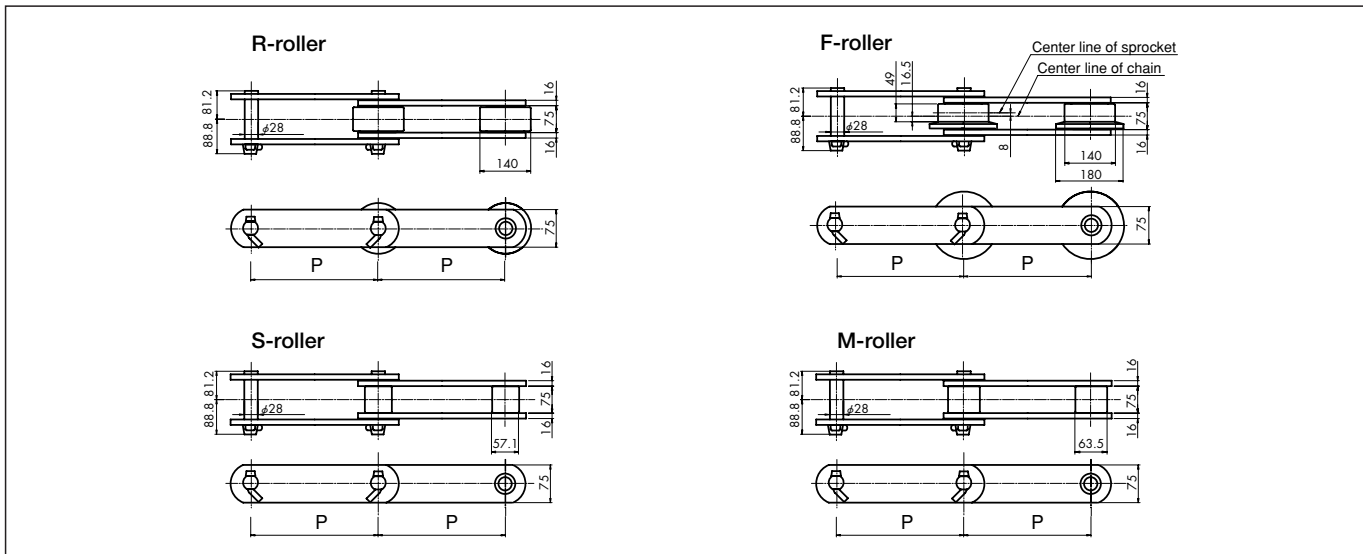

Chain No.		Avg. tensile strength kN (kgf)		Pitch	Standard attachments											
Chain size	Roller type	Normal <b>A,J</b>	Heavy duty <b>K,E</b>	P	A1 · K1		A2 · K2		A3 · K3		SA2 · SK2		GA2 · GK2		G4	
					N	K	N	K	N	K	N	K	K	Y	B	
<b>DK 65300</b>	<b>R,F,S,M</b>	637	882	300	—	180	130	—	—	—	—	—	120(80)	170	100	160
<b>DK 65450</b>	<b>R,F,S,M</b>	(65,000)	(90,000)	450	—	—	—	330	140	—	—	—	200	—	—	—

Chain No.		Combination of standard attachments and rollers						Approx. weight kg/m				Attachment weight (kg)				
Chain size	Roller type	A1 K1	A2 K2	A3 K3	SA2 SK2	GA2 GK2	G4	R-roller	F-roller	S-roller	M-roller	A2	A3	K2	K3	G4
<b>DK 65300</b>	<b>R,F,S,M</b>	—	R,F,S,M	—	—	R,F,S,M	R,F,S,M	47.8	51.2	28.9	30.1	3.44	—	6.88	—	2.81
<b>DK 65450</b>	<b>R,F,S,M</b>	—	—	R,F,S,M	—	R,F,S,M	—	37.0	39.3	25.5	26.3	—	6.30	—	12.6	—

- Note: 1. The dimensions of the normal and heavy duty chains are the same, but heavy duty chains are made of high-strength and structural steel, and are suitable when higher safety rate, strength or wear resistance is required.  
 2. K values in ( ) for Attachment GA2 and GK2 are for Roller F.  
 3. With Attachment GA2 and GK2, check the bolt length limits shown above.  
 4. Attachment A3 and K3 are angle welding attachments.

DK Conveyor Chains  
Standard Conveyor Chain

## Dimensional Drawings: DK 05101 (for Inch series)

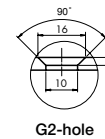
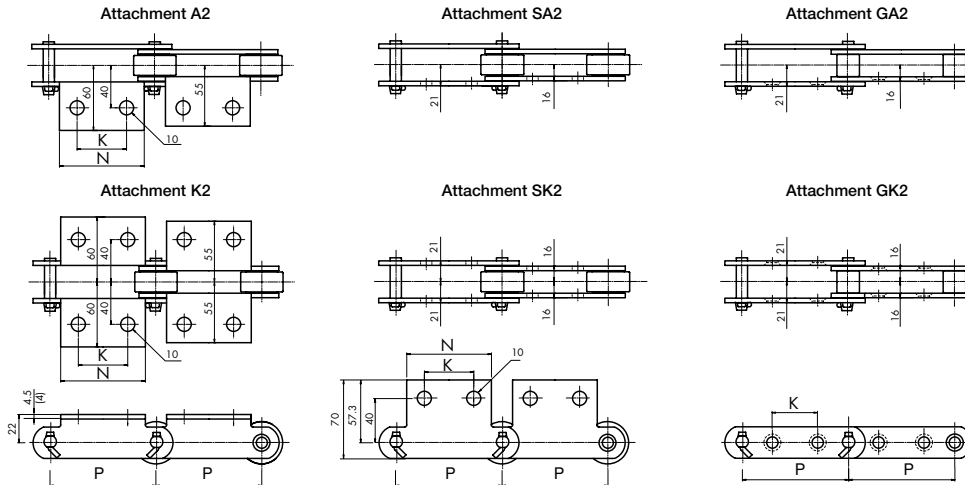
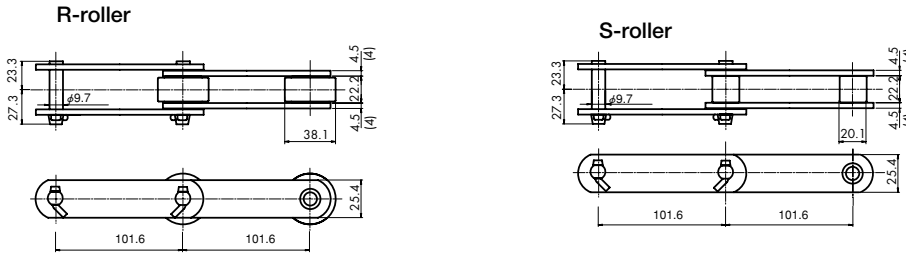

**Bolt: M8**  
**Bolt length limits**  
 Outer link: 32mm  
 Inner link: 25mm

Chain No.		Avg. tensile strength kN (kgf)		Pitch	Standard attachments											
Chain size	Roller type	Normal <b>A,J</b>	Heavy duty <b>K,E</b>	P	A1 · K1		A2 · K2		A3 · K3		SA2 · SK2		GA2 · GK2		G4	
		N	K		N	K	N	K	N	K	N	K	K	K	Y	B
<b>DK 05101</b>	<b>R,S</b>	53.9 (5,500)	98 (10,000)	101.6	—	70	40	—	—	70	40	45	—	—	—	—

Chain No.		Combination of standard attachments and rollers						Approx. weight kg/m				Attachment weight (kg)				
Chain size	Roller type	A1 K1	A2 K2	A3 K3	SA2 SK2	GA2 GK2	G4	R-roller	F-roller	S-roller	M-roller	A2 SA2	A3	K2 SK2	K3	G4
<b>DK 05101</b>	<b>R,S</b>	—	R,S	—	R,S	R,S	—	4.1	—	2.9	—	0.12	—	0.24	—	—

Note: 1. Values in ( ) for the plate thickness are for the stainless steel chains. Values for plate thickness without ( ) apply to all types.  
 2. The dimensions of the normal and heavy duty chains are the same, but heavy duty chains are made of high-strength and structural steel, and are suitable when higher safety rate, strength or wear resistance is required.  
 3. With Attachment GA2 and GK2, check the bolt length limits shown above.

DK Conveyor Chains  
Standard Conveyor Chain

# Dimensional Drawings: DK 08066 and DK 08101 (for Inch series)

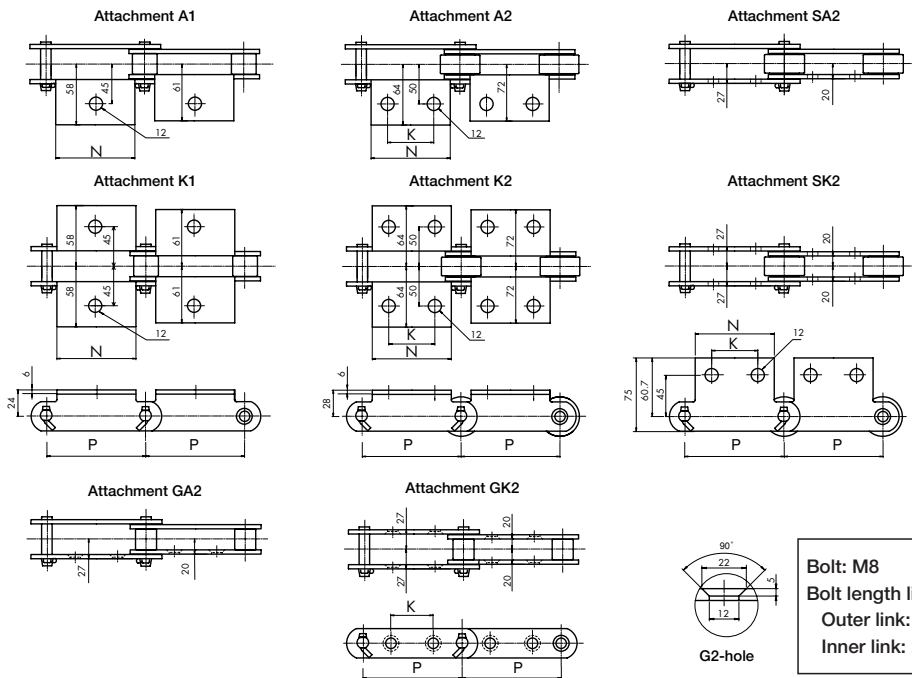
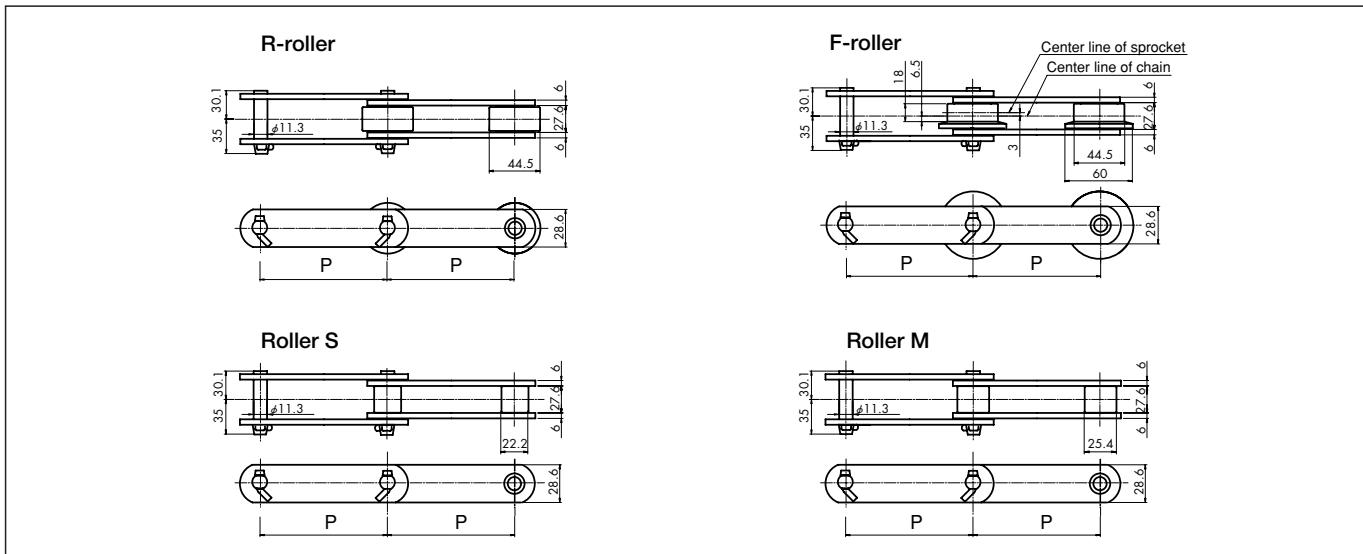

**Bolt: M8**  
**Bolt length limits**  
**Outer link: 35mm**  
**Inner link: 25mm**

Chain No.		Avg. tensile strength kN (kgf)		Pitch	Standard attachments											
Chain size	Roller type	Normal <b>A,J</b>	Heavy duty <b>K,E</b>	P	A1 · K1		A2 · K2		A3 · K3		SA2 · SK2		GA2 · GK2		G4	
					N	K	N	K	N	K	K	K	Y	B		
<b>DK 08066</b>	<b>S,M</b>	78.4 (8,000)	142 (14,500)	66.27	35	—	—	—	—	—	—	—	—	—	—	—
<b>DK 08101</b>	<b>R,F,S,M</b>			101.6	—	70	40	—	—	70	40	35	—	—	—	—

Chain No.		Combination of standard attachments and rollers						Approx. weight kg/m				Attachment weight (kg)				
Chain size	Roller type	A1	A2	A3	SA2	GA2	G4	R-roller	F-roller	S-roller	M-roller	A1,A2 SA2	A3	K1,K2 SK2	K3	G4
		K1	K2	K3	SK2	GK2										
<b>DK 08066</b>	<b>S,M</b>	S,M	—	—	—	—	—	—	—	5.3	5.8	0.08	—	0.16	—	—
<b>DK 08101</b>	<b>R,F,S,M</b>	—	R,F,S,M	—	R,F,S,M	R,F,S,M	—	6.9	7.3	4.5	5.1	0.20	—	0.40	—	—

Note: 1. The dimensions of the normal and heavy duty chains are the same, but heavy duty chains are made of high-strength and structural steel, and are suitable when higher safety rate, strength or wear resistance is required.  
 2. With Attachment GA2 and GK2, check the bolt length limits shown above.

DK Conveyor Chains  
Standard Conveyor Chain



## Dimensional Drawings: DK 09101 (for Inch series)

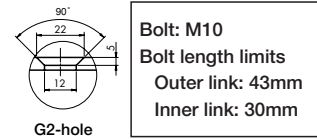
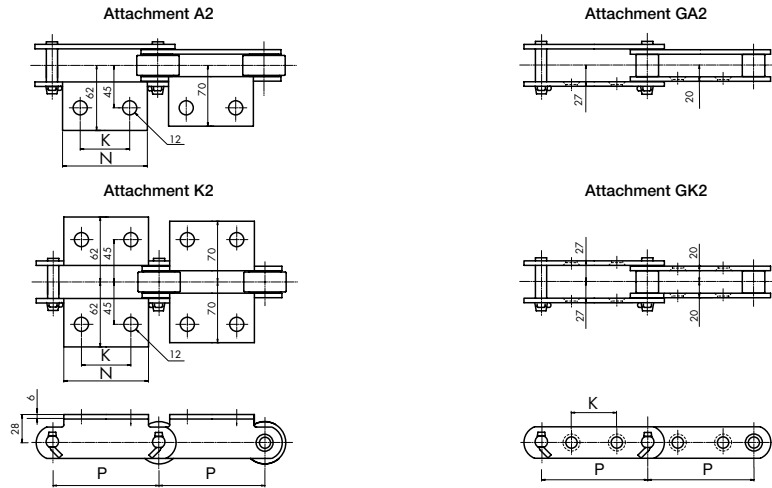
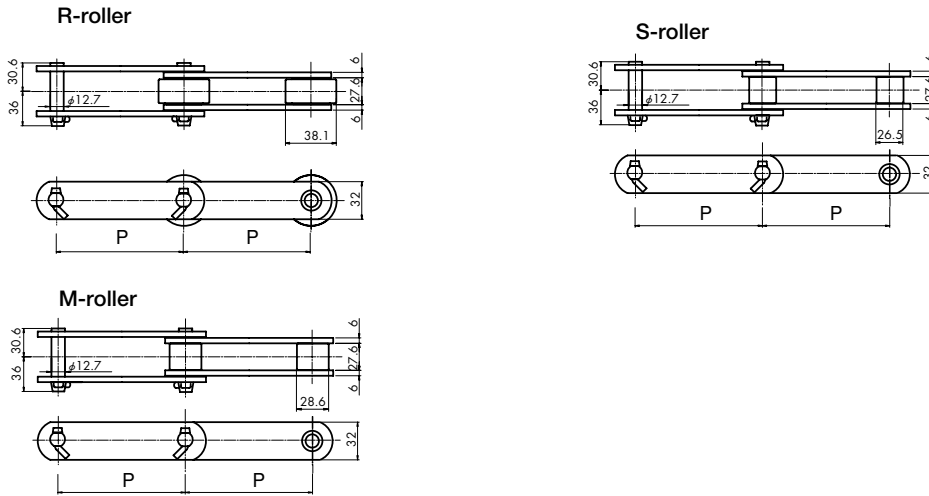

Chain No.		Avg. tensile strength kN (kgf)		Pitch	Standard attachments											
Chain size	Roller type	Normal <b>A,J</b>	Heavy duty <b>K,E</b>	P	A1 · K1		A2 · K2		A3 · K3		SA2 · SK2		GA2 · GK2		G4	
					N	N	K	N	K	N	K	K	K	Y	B	
<b>DK 09101</b>	<b>R,S,M</b>	88.2 (9,000)	156 (16,000)	101.6	—	70	40	—	—	—	—	40	—	—	—	

Chain No.		Combination of standard attachments and rollers						Approx. weight kg/m				Attachment weight (kg)				
Chain size	Roller type	A1	A2	A3	SA2	GA2	G4	R-roller	F-roller	S-roller	M-roller	A2	A3	K2	K3	G4
		K1	K2	K3	SK2	GK2										
<b>DK 09101</b>	<b>R,S,M</b>	—	R,S,M	—	—	R,S,M	—	6.4	—	5.4	5.7	0.19	—	0.38	—	—

Note: 1. The dimensions of the normal and heavy duty chains are the same, but heavy duty chains are made of high-strength and structural steel, and are suitable when higher safety rate, strength or wear resistance is required.  
 2. With Attachment GA2 and GK2, check the bolt length limits shown above.

DK Conveyor Chains  
Standard Conveyor Chain

# Dimensional Drawings: DK 11152 (for Inch series)

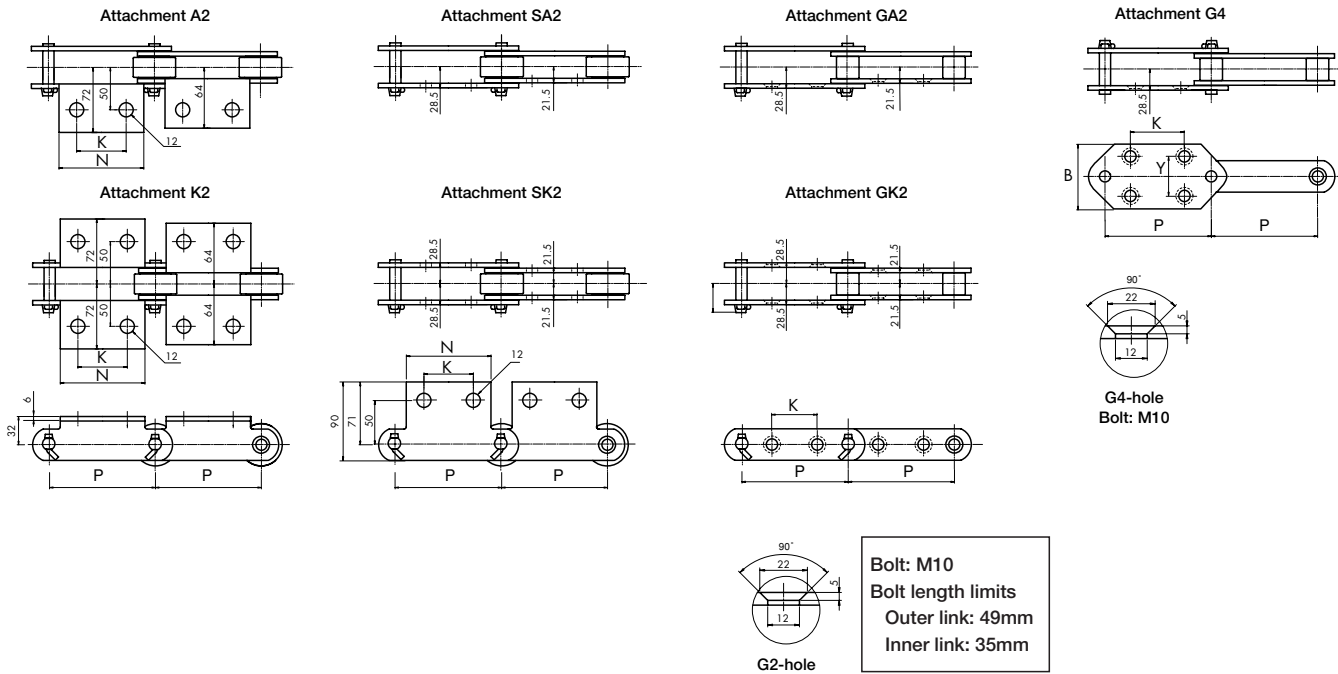
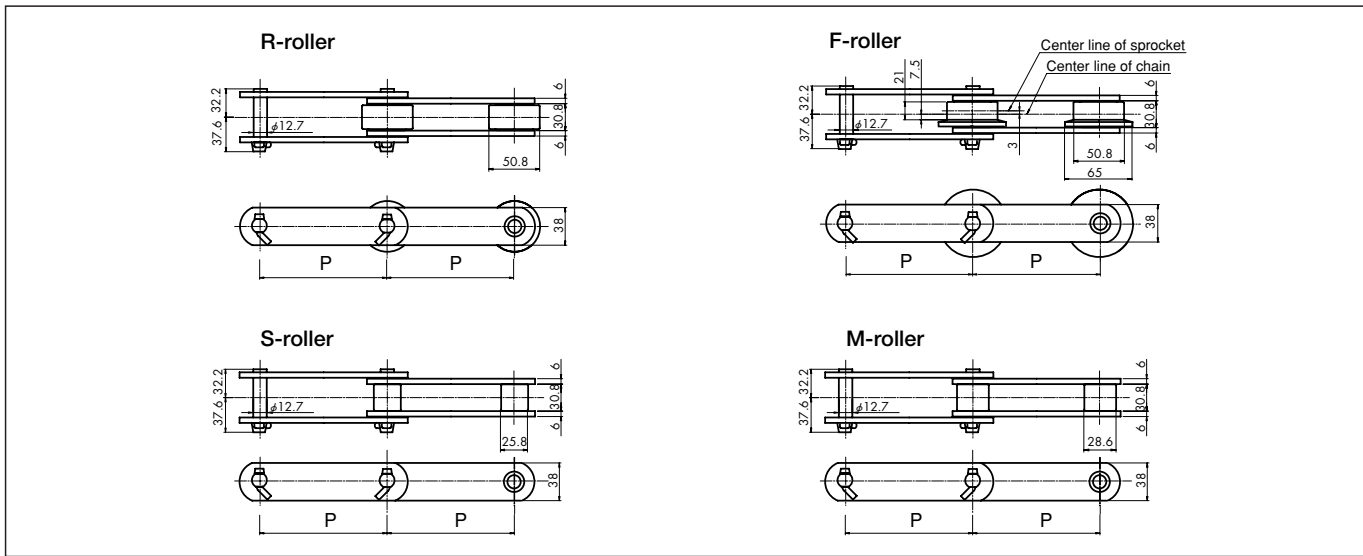

DK Conveyor Chains  
Standard Conveyor Chain

Chain No.		Avg. tensile strength kN (kgf)		Pitch	Standard attachments										
Chain size	Roller type	Normal <b>A,J</b>	Heavy duty <b>K,E</b>	P	A1 · K1 N	A2 · K2 N	A3 · K3 K	SA2 · SK2 N	GA2 · GK2 K	G4 K Y B					
<b>DK 11152</b>	<b>R,F,S,M</b>	112 (11,500)	171 (17,500)	152.4	—	90	60	—	—	—	—	60	75	70	110

Chain No.		Combination of standard attachments and rollers						Approx. weight kg/m				Attachment weight (kg)				
Chain size	Roller type	A1 K1	A2 K2	A3 K3	SA2 SK2	GA2 GK2	G4	R-roller	F-roller	S-roller	M-roller	A2	A3	K2	K3	G4
<b>DK 11152</b>	<b>R,F,S,M</b>	—	R,F,S,M	—	R,S,M	R,F,S,M	—	7.4	7.9	5.5	5.8	0.22	—	0.44	—	—

Note: 1. The dimensions of the normal and heavy duty chains are the same, but heavy duty chains are made of high-strength and structural steel, and are suitable when higher safety rate, strength or wear resistance is required.  
2. With Attachment GA2 and GK2, check the bolt length limits shown above.

## Dimensional Drawings: DK 13101 (for Inch series)

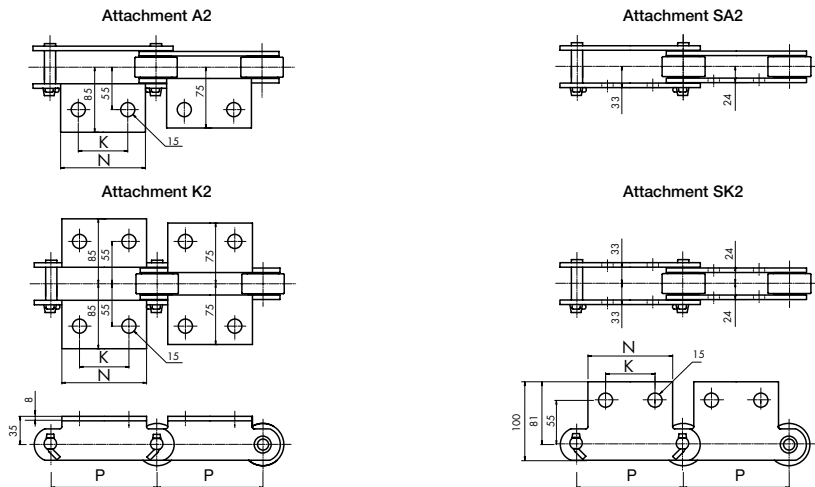
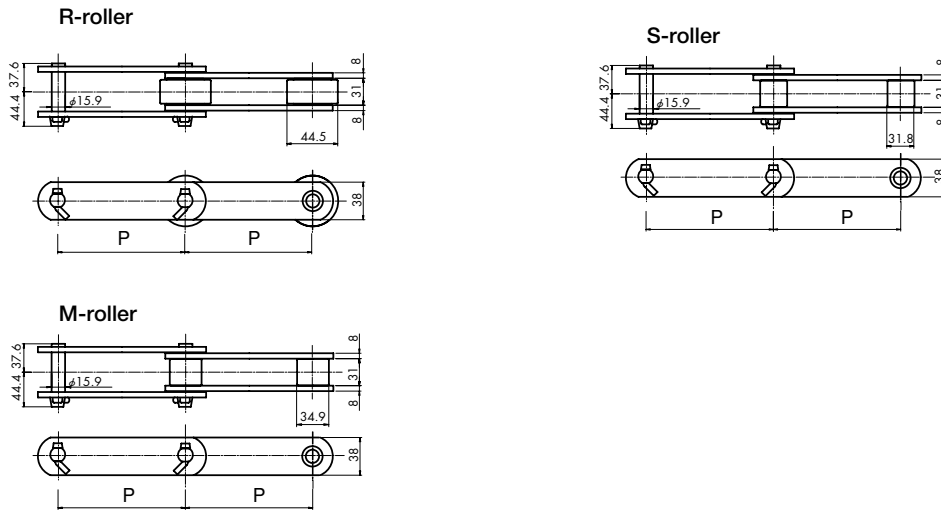

Chain No.		Avg. tensile strength kN (kgf)		Pitch	Standard attachments											
Chain size	Roller type	Normal	Heavy duty	P	A1 · K1		A2 · K2		A3 · K3		SA2 · SK2		GA2 · GK2		G4	
		A,J	K,E		N	N	K	N	K	N	K	K	K	Y	B	
<b>DK 13101</b>	<b>R,S,M</b>	127 (13,000)	240 (24,500)	101.6	—	80	40	—	—	80	40	—	—	—	—	

Chain No.		Combination of standard attachments and rollers						Approx. weight kg/m				Attachment weight (kg)				
Chain size	Roller type	A1	A2	A3	SA2	GA2	G4	R-roller	F-roller	S-roller	M-roller	A2	A3	K2	K3	G4
		K1	K2	K3	SK2	GK2						SA2		SK2		
<b>DK 13101</b>	<b>R,S,M</b>	—	R,S,M	—	R,S,M	—	—	10.3	—	9.6	10.0	0.31	—	0.62	—	—

Note: The dimensions of the normal and heavy duty chains are the same, but heavy duty chains are made of high-strength and structural steel, and are suitable when higher safety rate, strength or wear resistance is required.

# Dimensional Drawings: DK 19152 (for Inch series)

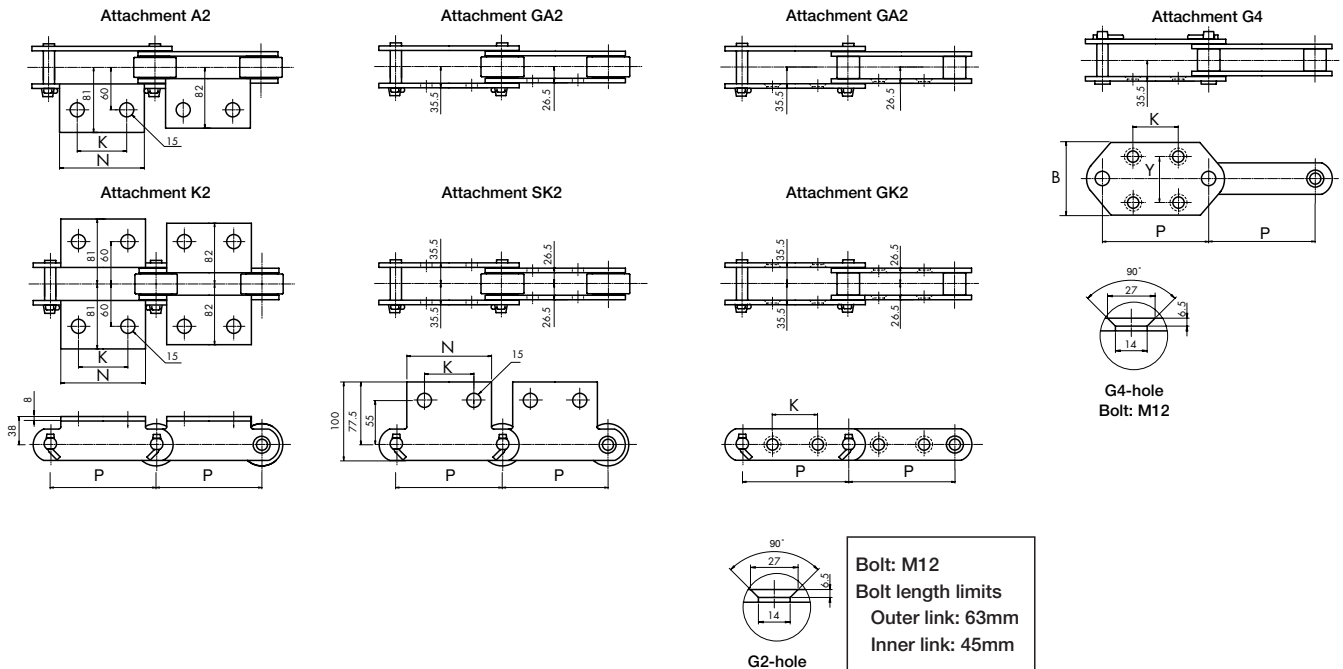
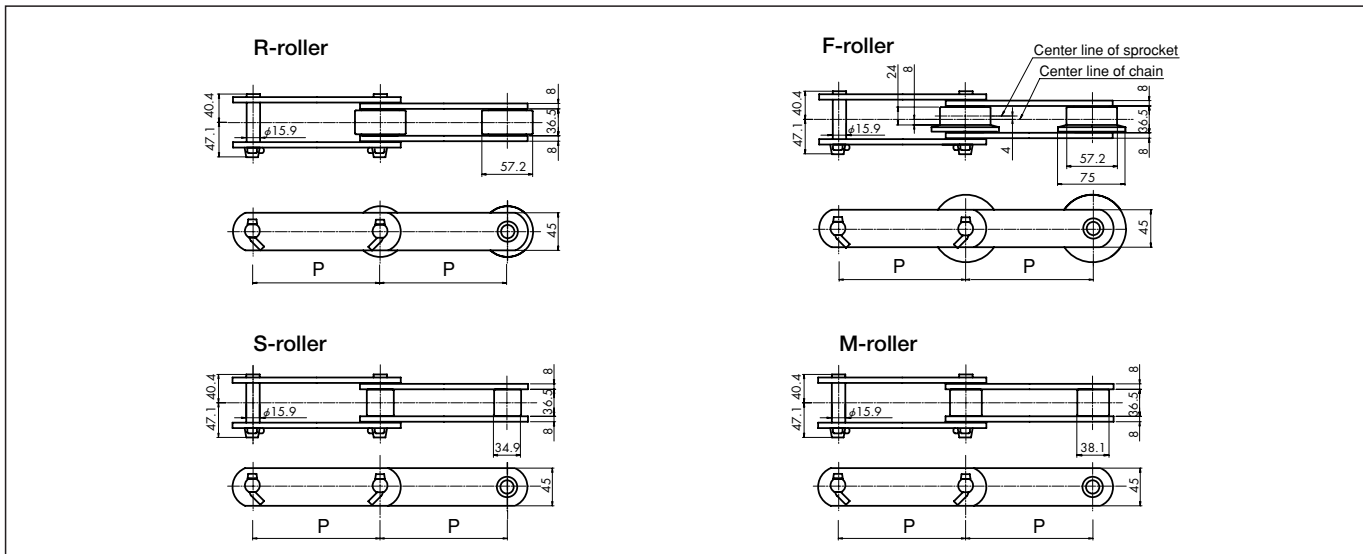

Chain No.		Avg. tensile strength kN (kgf)		Pitch	Standard attachments											
Chain size	Roller type	Normal <b>A,J</b>	Heavy duty <b>K,E</b>	P	A1 · K1		A2 · K2		A3 · K3		SA2 · SK2		GA2 · GK2		G4	
					N	N	K	N	K	N	K	K	K	Y	B	
<b>DK 19152</b>	<b>R,F,S,M</b>	186 (19,000)	279 (28,500)	152.4	—	100	60	—	—	100	60	50	75	70	110	

Chain No.		Combination of standard attachments and rollers						Approx. weight kg/m				Attachment weight (kg)				
Chain size	Roller type	A1	A2	A3	SA2	GA2	G4	R-roller	F-roller	S-roller	M-roller	A2	A3	K2	K3	G4
		K1	K2	K3	SK2	GK2						SA2		SK2		
<b>DK 19152</b>	<b>R,F,S,M</b>	—	R,F,S,M	—	R,S,M	R,F,S,M	—	11.8	12.2	9.1	9.4	0.41	—	0.82	—	0.60

Note: 1. The dimensions of the normal and heavy duty chains are the same, but heavy duty chains are made of high-strength and structural steel, and are suitable when higher safety rate, strength or wear resistance is required.  
 2. With Attachment GA2 and GK2, check the bolt length limits shown above.

DK Conveyor Chains  
Standard Conveyor Chain

## Dimensional Drawings: DK 25152 (for Inch series)

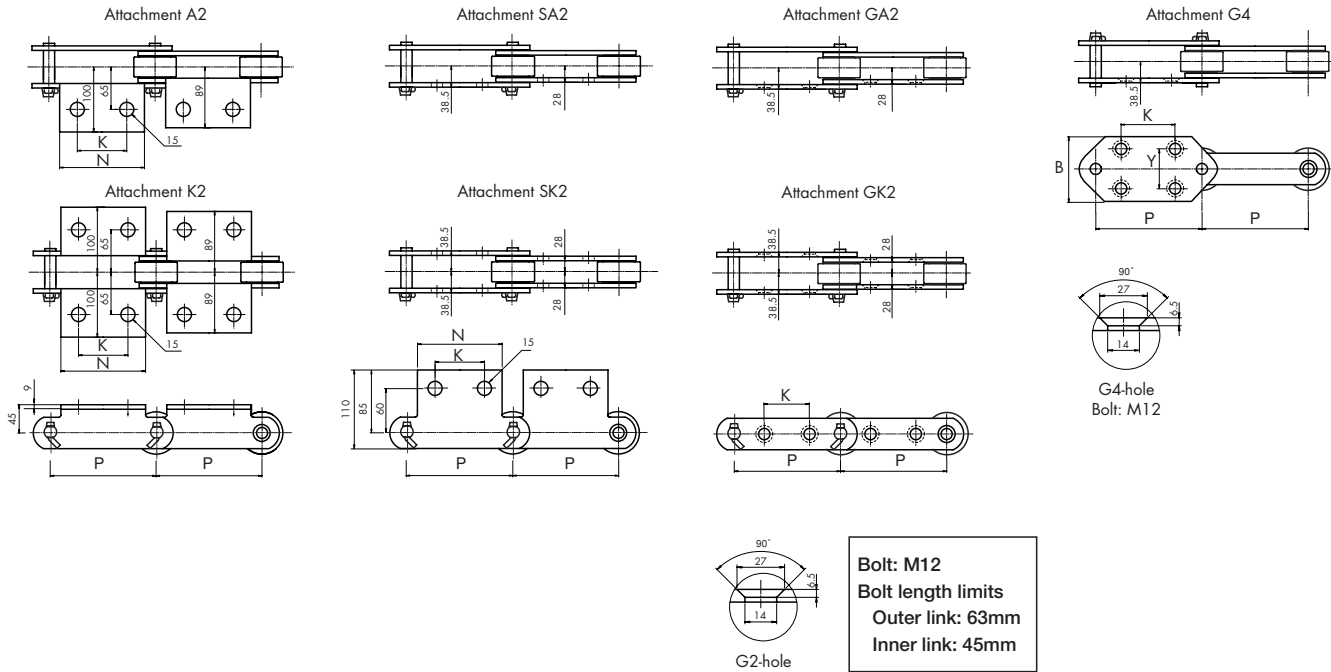
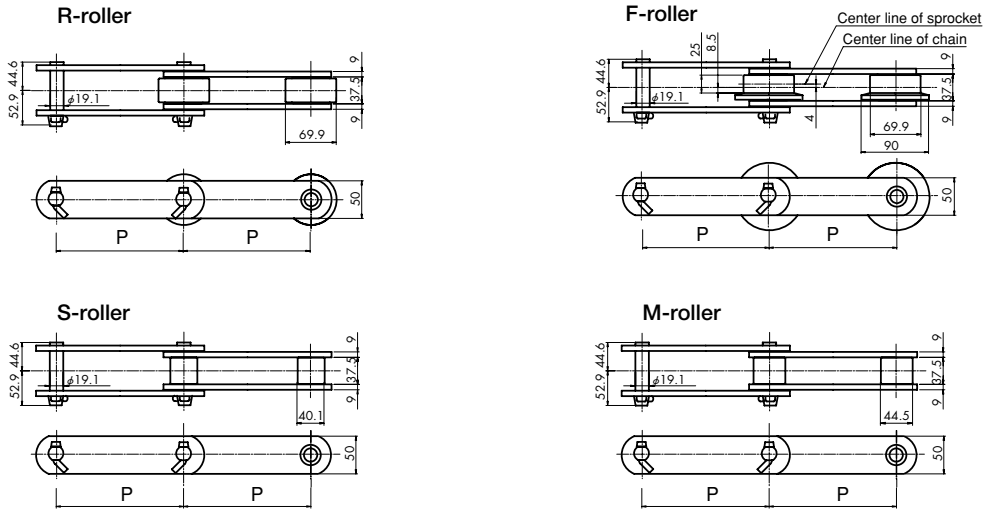

Chain No.		Avg. tensile strength kN (kgf)		Pitch	Standard attachments												
Chain size	Roller type	Normal	Heavy duty	P	A1 · K1		A2 · K2		A3 · K3		SA2 · SK2		GA2 · GK2		G4		
		A,J	K,E		N	N	K	N	K	N	K	K	K	Y	B		
<b>DK 25152</b>	<b>R,F,S,M</b>	245 (25,000)	392 (40,000)	152.4	—	100	60	—	—	100	60	55(35)	75	70	125		

Chain No.		Combination of standard attachments and rollers						Approx. weight kg/m				Attachment weight (kg)				
Chain size	Roller type	A1	A2	A3	SA2	GA2	G4	R-roller	F-roller	S-roller	M-roller	A2	A3	K2	K3	G4
		K1	K2	K3	SK2	GK2						SA2		SK2		
<b>DK 25152</b>	<b>R,F,S,M</b>	—	R,F,S,M	—	R,S,M	R,F,S,M	—	11.8	12.2	9.1	9.4	0.53	—	1.06	—	0.79

Note: 1. The dimensions of the normal and heavy duty chains are the same, but heavy duty chains are made of high-strength and structural steel, and are suitable when higher safety rate, strength or wear resistance is required.  
 2. K values in ( ) for Attachment GA2 and GK2 are for Roller F.  
 3. With Attachment GA2 and GK2, check the bolt length limits shown above.

DK Conveyor Chains  
Standard Conveyor Chain

## Anti-seizing Roller Conveyor Chain

This chain has a larger clearance between the bushing outer diameter and roller inner diameter compared to that of standard conveyor chains to prevent interference with chain rotation even when various loads enter into the roller bearing.

- The chain body is identical to Standard Conveyor Chains with Roller R and Roller F.
- Sprockets for Standard Conveyor Chains can be used.
- Dimensions for attachments are also identical to those of Standard Conveyor Chains.

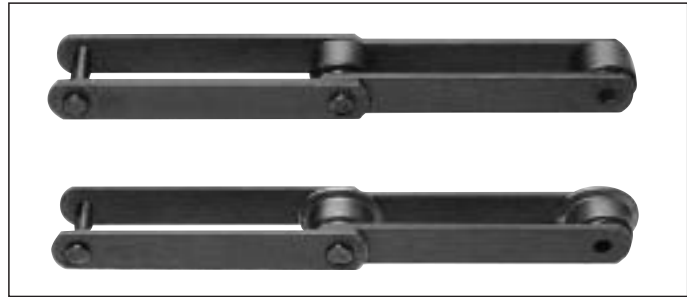

## Application examples

- Apron conveyors and scraper conveyors for industrial waste of recycling centers and for refuse incineration ash and wet refuse of waste disposal facilities
- Circumstances where smooth rotation is inhibited by fixing of loads.



## Table of applicable attachments

Chain No.	Roller	Standard attachment												
		A1	A2	A3	K1	K2	K3	SA1	SA2	SK1	SK2	GA2	GK2	G4
DK 03075	UR,UF	×	○	×	×	○	×	×	○	×	○	×	×	×
DK 03100	UR,UF	×	○	×	×	○	×	×	○	×	○	×	×	×
DK 03125	UR,UF	×	○	×	×	○	×	×	○	×	○	×	×	×
DK 03150	UR,UF	×	○	×	×	○	×	×	○	×	○	×	×	×
DK 07075	UR,UF	×	○	×	×	○	×	×	○	×	○	×	×	×
DK 07100	UR,UF	×	○	×	×	○	×	×	○	×	○	×	×	×
DK 07125	UR,UF	×	○	×	×	○	×	×	○	×	○	×	×	×
DK 07150	UR,UF	×	○	×	×	○	×	×	○	×	○	×	×	×
DK 09100	UR,UF	×	○	×	×	○	×	×	○	×	○	×	×	×
DK 09125	UR,UF	×	○	×	×	○	×	×	○	×	○	×	×	×
DK 09150	UR,UF	×	○	×	×	○	×	×	○	×	○	×	×	×
DK 09200	UR,UF	×	○	×	×	○	×	×	○	×	○	×	×	×
DK 11100	UR,UF	×	○	×	×	○	×	×	○	×	○	×	×	×
DK 11125	UR,UF	×	○	×	×	○	×	×	○	×	○	×	×	×
DK 11150	UR,UF	×	○	×	×	○	×	×	○	×	○	×	×	×
DK 11200	UR,UF	×	○	×	×	○	×	×	○	×	○	×	×	×
DK 13150	UR,UF	×	○	×	×	○	×	×	○	×	○	×	×	×
DK 13200	UR,UF	×	○	×	×	○	×	×	○	×	○	×	×	×
DK 19200	UR,UF	×	○	×	×	○	×	×	○	×	○	×	×	×
DK 19250	UR,UF	×	○	×	×	○	×	×	○	×	○	×	×	×
DK 19300	UR,UF	×	○	×	×	○	×	×	○	×	○	×	×	×
DK 25200	UR,UF	×	○	×	×	○	×	×	○	×	○	×	×	×
DK 25250	UR,UF	×	○	×	×	○	×	×	○	×	○	×	×	×
DK 25300	UR,UF	×	○	×	×	○	×	×	○	×	○	×	×	×
DK 32200	UR,UF	×	○	×	×	○	×	×	○	×	○	×	×	×
DK 32250	UR,UF	×	○	×	×	○	×	×	○	×	○	×	×	×
DK 32300	UR,UF	×	○	×	×	○	×	×	○	×	○	×	×	×
DK 32450	UR,UF	×	○	×	×	○	×	×	○	×	○	×	×	×
DK 50250	UR,UF	×	○	×	×	○	×	×	○	×	○	×	×	×
DK 50300	UR,UF	×	○	×	×	○	×	×	○	×	○	×	×	×
DK 50450	UR,UF	×	×	○	×	×	○	×	×	×	○	×	×	×
DK 50600	UR,UF	×	×	○	×	×	○	×	×	×	○	×	×	×
DK 65300	UR,UF	×	○	×	×	○	×	×	○	×	○	×	×	×
DK 65450	UR,UF	×	×	○	×	×	○	×	×	×	○	×	×	×
DK 05101	UR	×	○	×	×	○	×	×	○	×	○	×	×	×
DK 08101	UR,UF	×	○	×	×	○	×	×	○	×	○	×	×	×
DK 09101	UR	×	○	×	×	○	×	×	○	×	○	×	×	×
DK 11152	UR,UF	×	○	×	×	○	×	×	○	×	○	×	×	×
DK 13101	UR	×	○	×	×	○	×	×	○	×	○	×	×	×
DK 19152	UR,UF	×	○	×	×	○	×	×	○	×	○	×	×	×
DK 25152	UR,UF	×	○	×	×	○	×	×	○	×	○	×	×	×

○ : Standard product    × : Nonstandard product  
 Note: Consult us for manufacturing nonstandard products.

## Dimensional Drawings: DK 03075, DK 03100, DK 03125 and DK 03150 (for Metric series)

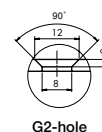
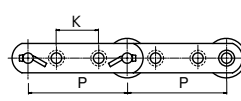
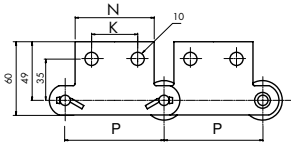
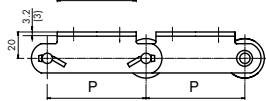
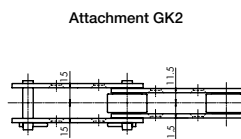
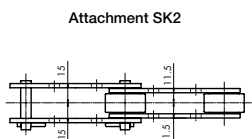
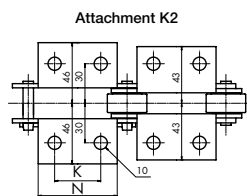
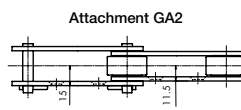
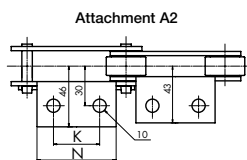
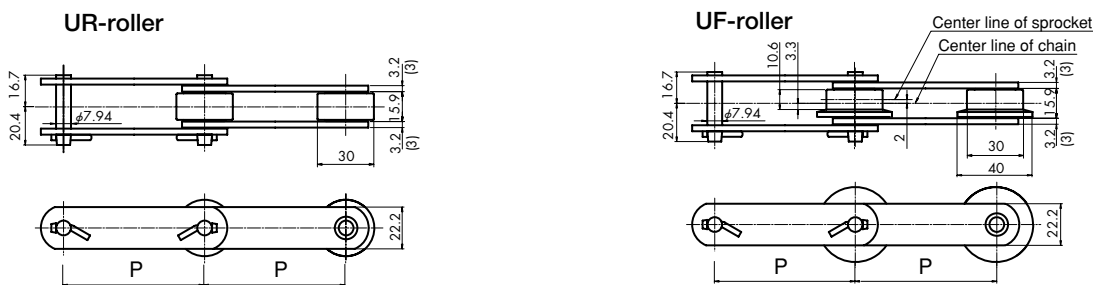

**Bolt: M6**  
**Bolt length limits**  
**Outer link: 23**  
**Inner link: 16**

Chain No.		Avg. tensile strength kN (kgf)		Pitch	Standard attachments											
Chain size	Roller type	Normal A,J	Heavy duty K,E	P	A1 · K1		A2 · K2		A3 · K3		SA2 · SK2		GA2 · GK2		G4	
					N	K	N	K	N	K	N	K	K	Y	B	
DK 03075	UR,UF	34.3 (3,500)	69.6 (7,100)	75	—	60	35	—	—	60	35	—	—	—	—	
DK 03100	UR,UF			100	—	65	40	—	—	65	40	40	—	—	—	
DK 03125	UR,UF			125	—	75	50	—	—	—	—	50	—	—	—	
DK 03150	UR,UF			150	—	85	60	—	—	—	—	60	—	—	—	

Chain No.		Combination of standard attachments and rollers						Approx. weight kg/m		Attachment weight (kg)				
Chain size	Roller type	A1	A2	A3	SA2	GA2	G4	UR-roller	UF-roller	A2	A3	K2	K3	G4
		K1	K2	K3	SK2	GK2	SA2			SK2	K3	G4		
DK 03075	UR,UF	—	UR,UF	—	UR	—	—	2.6	2.8	0.05	—	0.10	—	—
DK 03100	UR,UF	—	UR,UF	—	UR	UR,UF	—	2.2	2.4	0.06	—	0.12	—	—
DK 03125	UR,UF	—	UR,UF	—	—	UR,UF	—	2.0	2.1	0.07	—	0.14	—	—
DK 03150	UR,UF	—	UR,UF	—	—	UR,UF	—	1.8	1.8	0.08	—	0.16	—	—

Note: 1. Values in ( ) for the plate thickness are for the stainless steel chains. Values for plate thickness without ( ) apply to all types.  
 2. The dimensions of the normal and heavy duty chains are the same, but heavy duty chains are made of high-strength and structural steel, and are suitable when higher safety rate, strength or wear resistance is required.  
 3. With Attachment GA2 and GK2, check the bolt length limits shown above.



Dimensional Drawings: DK 07075, DK 07100, DK 07125 and DK 07150 (for Metric series)

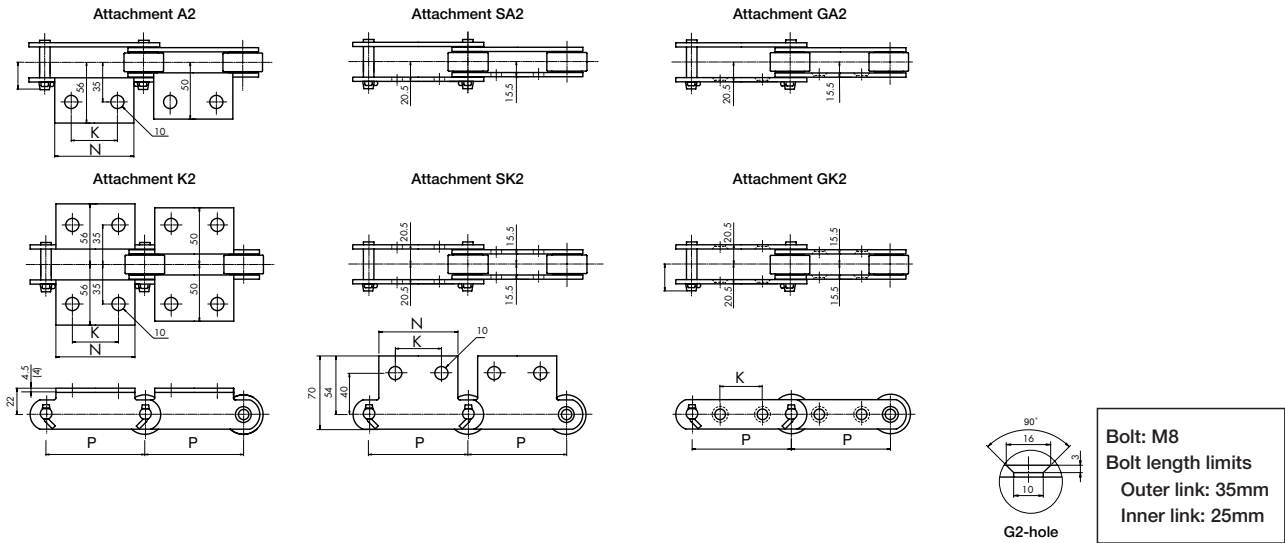
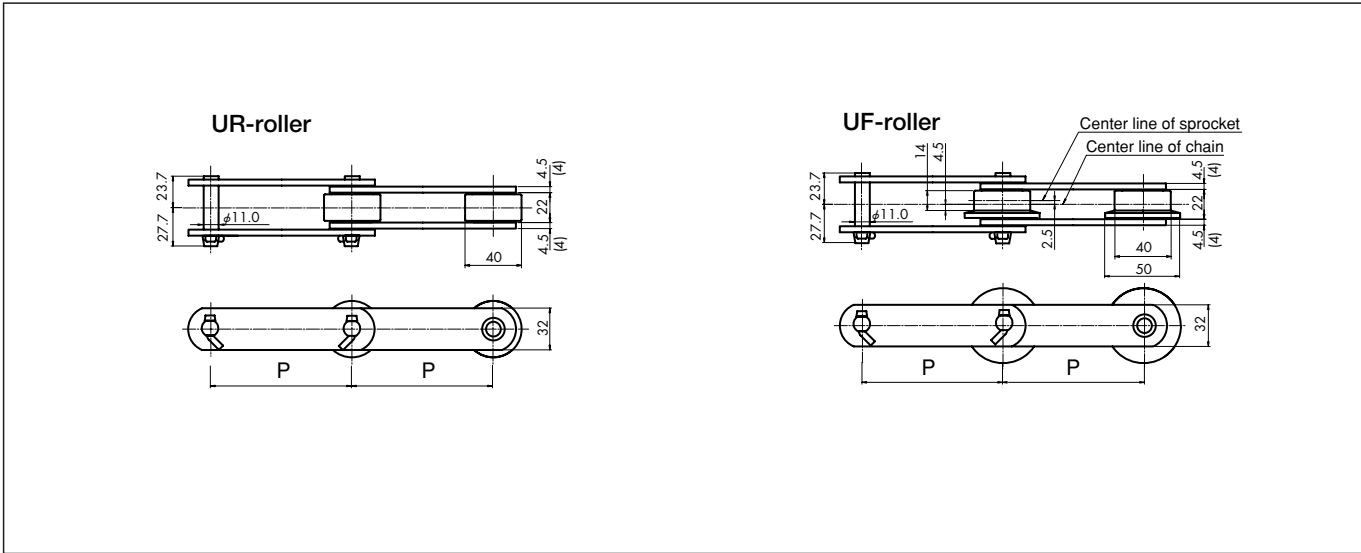

Chain No.		Avg. tensile strength kN (kgf)		Pitch	Standard attachments												
Chain size	Roller type	Normal A,J	Heavy duty K,E	P	A1 · K1		A2 · K2		A3 · K3		SA2 · SK2		GA2 · GK2		G4		
					K	N	K	N	K	N	K	K	K	K	Y	B	
DK 07075	UR,UF	68.6 (7,000)	132 (13,500)	75	—	60	35	—	—	—	—	—	—	—	—	—	
DK 07100	UR,UF			100	—	65	40	—	—	65	40	40(34)	—	—	—	—	—
DK 07125	UR,UF			125	—	75	50	—	—	—	—	50	—	—	—	—	—
DK 07150	UR,UF			150	—	85	60	—	—	85	60	60	—	—	—	—	—

Chain No.		Combination of standard attachments and rollers					Approx. weight kg/m		Attachment weight (kg)					
Chain size	Roller type	A1 K1	A2 K2	A3 K3	SA2 SK2	GA2 GK2	G4	UR-roller	UF-roller	A2 SA2	A3	K2 SK2	K3	G4
DK 07075	UR,UF	—	UR,UF	—	—	—	—	5.6	5.9	0.09	—	0.18	—	—
DK 07100	UR,UF	—	UR,UF	—	UR	UR,UF	—	5.0	5.2	0.10	—	0.20	—	—
DK 07125	UR,UF	—	UR,UF	—	—	UR,UF	—	4.6	4.8	0.12	—	0.24	—	—
DK 07150	UR,UF	—	UR,UF	—	UR	UR,UF	—	4.2	4.4	0.13	—	0.26	—	—

- Note: 1. in ( ) for the plate thickness are for the stainless steel chains. Values for plate thickness without ( ) apply to all types.  
 2. The dimensions of the normal and heavy duty chains are the same, but heavy duty chains are made of high-strength and structural steel, and are suitable when higher safety rate, strength or wear resistance is required.  
 3. K values in ( ) for Attachment GA2 and GK2 are for Roller UF.  
 4. With Attachment GA2 and GK2, check the bolt length limits shown above.

## Dimensional Drawings: DK 09100, DK 09125, DK 09150 and DK 09200 (for Metric series)

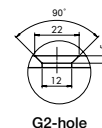
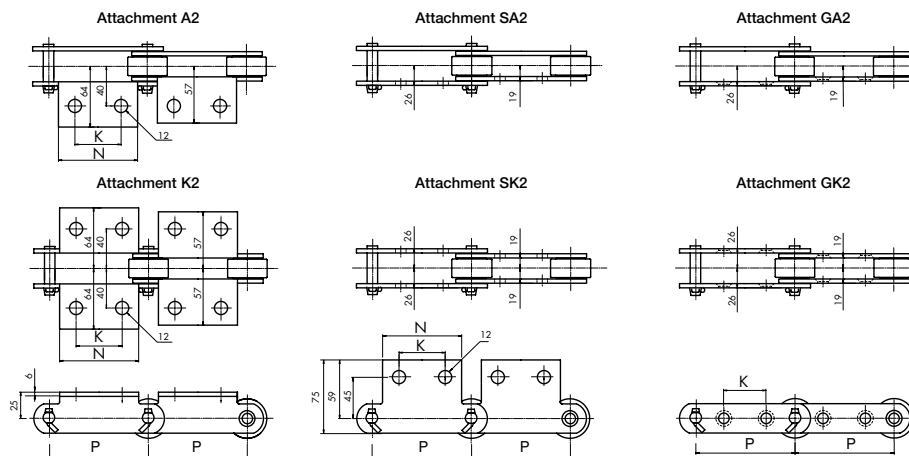
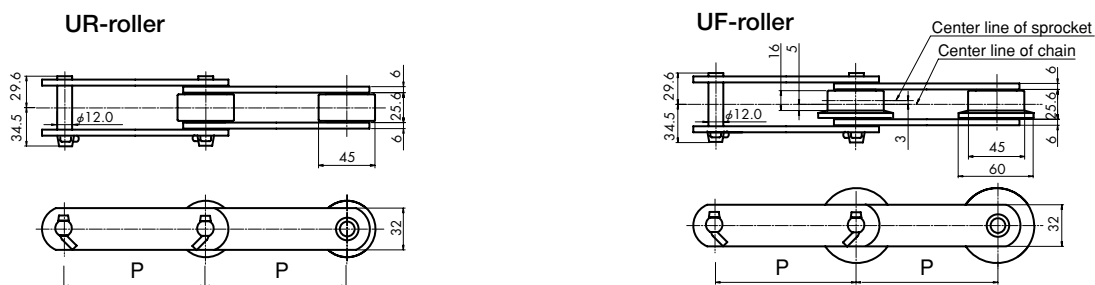

**Bolt: M10**  
**Bolt length limits**  
 Outer link: 43mm  
 Inner link: 30mm

Chain No.		Avg. tensile strength kN (kgf)		Pitch	Standard attachments										
Chain size	Roller type	Normal A,J	Heavy duty K,E	P	A1 · K1 N	A2 · K2 N	A3 · K3 N	A3 · K3 K	SA2 · SK2 N	SA2 · SK2 K	GA2 · GK2 K	G4 K Y B			
<b>DK 09100</b>	<b>UR,UF</b>	88.2 (9,000)	156 (16,000)	100	—	70	40	—	—	—	35	—	—	—	
<b>DK 09125</b>	<b>UR,UF</b>			125	—	80	50	—	—	—	45	—	—	—	
<b>DK 09150</b>	<b>UR,UF</b>			150	—	90	60	—	—	90	60	60	—	—	—
<b>DK 09200</b>	<b>UR,UF</b>			200	—	110	80	—	—	—	—	80	—	—	—

Chain No.		Combination of standard attachments and rollers						Approx. weight kg/m		Attachment weight (kg)				
Chain size	Roller type	A1 K1	A2 K2	A3 K3	SA2 SK2	GA2 GK2	G4	UR-roller	UF-roller	A2 SA2	A3	K2 SK2	K3	G4
<b>DK 09100</b>	<b>UR,UF</b>	—	UR,UF	—	—	—	—	7.1	7.4	0.16	—	0.32	—	—
<b>DK 09125</b>	<b>UR,UF</b>	—	UR,UF	—	—	UR,UF	—	6.4	6.6	0.18	—	0.36	—	—
<b>DK 09150</b>	<b>UR,UF</b>	—	UR,UF	—	UR	UR,UF	—	5.8	6.0	0.20	—	0.40	—	—
<b>DK 09200</b>	<b>UR,UF</b>	—	UR,UF	—	—	UR,UF	—	5.1	5.3	0.22	—	0.44	—	—

Note: 1. The dimensions of the normal and heavy duty chains are the same, but heavy duty chains are made of high-strength and structural steel, and are suitable when higher safety rate, strength or wear resistance is required.  
 2. With Attachment GA2 and GK2, check the bolt length limits shown above.

## Dimensional Drawings: DK 1100, DK 1125, DK 1150 and DK 1200 (for Metric series)

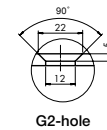
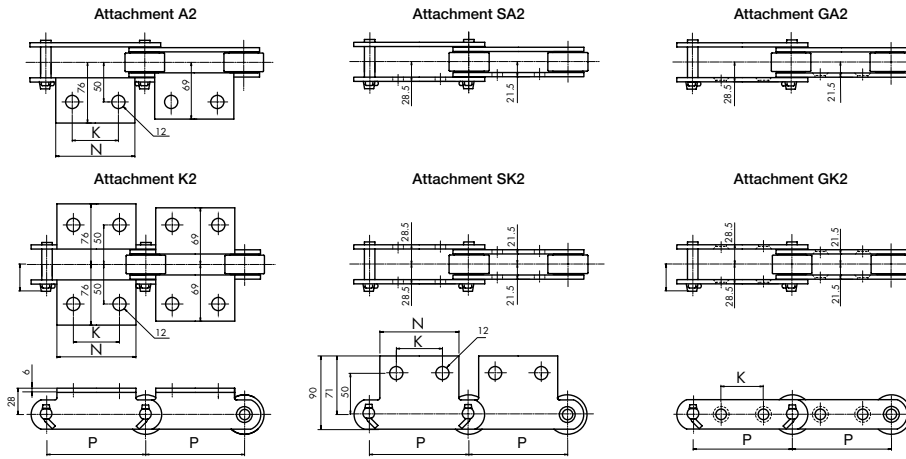
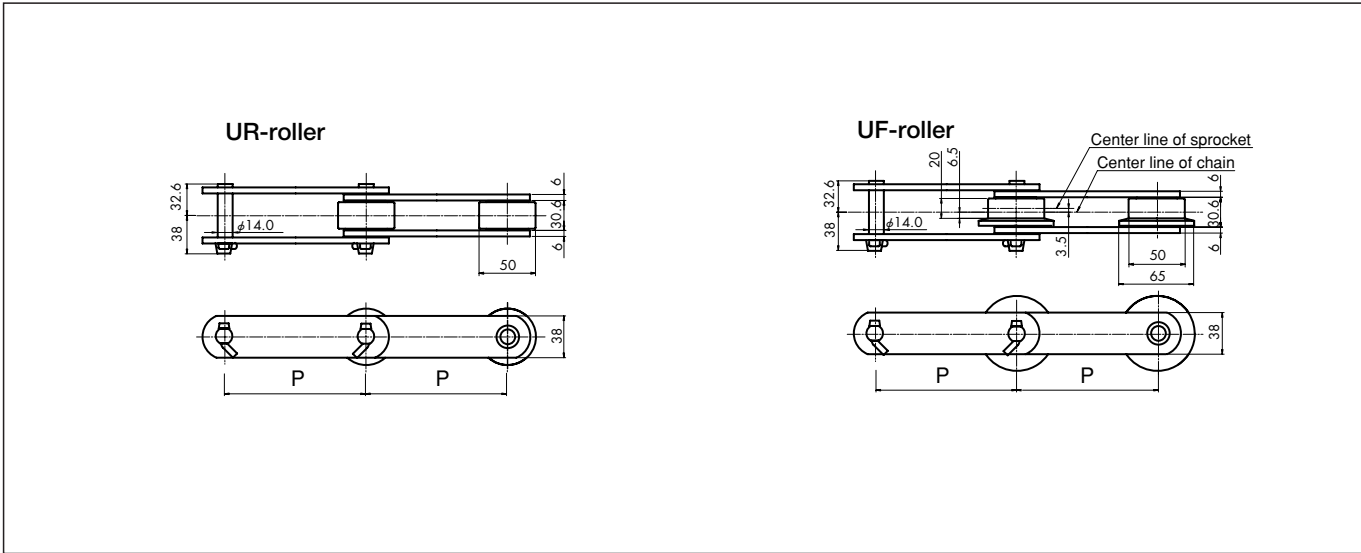

Bolt: M10  
 Bolt length limits  
 Outer link: 49mm  
 Inner link: 35mm

Chain No.		Avg. tensile strength kN (kgf)		Pitch	Standard attachments										
Chain size	Roller type	Normal A,J	Heavy duty K,E	P	A1 · K1 N	A2 · K2 N	A3 · K3 K	SA2 · SK2 N	SA2 · SK2 K	GA2 · GK2 K	G4 K Y B				
DK 11100	UR,UF	112 (11,500)	225 (23,000)	100	—	70	40	—	—	70	40	35	—	—	—
DK 11125	UR,UF			125	—	80	50	—	—	—	35	—	—	—	—
DK 11150	UR,UF			150	—	90	60	—	—	90	60	—	—	—	—
DK 11200	UR,UF			200	—	110	80	—	—	—	80	—	—	—	—

Chain No.		Combination of standard attachments and rollers						Approx. weight kg/m		Attachment weight (kg)				
Chain size	Roller type	A1 K1	A2 K2	A3 K3	SA2 SK2	GA2 GK2	G4	UR-roller	UF-roller	A2 SA2	A3	K2 SK2	K3	G4
DK 11100	UR,UF	—	UR,UF	—	UR	—	—	9.6	10.1	0.19	—	0.39	—	—
DK 11125	UR,UF	—	UR,UF	—	—	UR,UF	—	8.5	8.9	0.21	—	0.42	—	—
DK 11150	UR,UF	—	UR,UF	—	UR	UR,UF	—	7.6	7.9	0.24	—	0.48	—	—
DK 11200	UR,UF	—	UR,UF	—	—	UR,UF	—	6.5	6.8	0.29	—	0.58	—	—

Note: 1. The dimensions of the normal and heavy duty chains are the same, but heavy duty chains are made of high-strength and structural steel, and are suitable when higher safety rate, strength or wear resistance is required.  
 2. With Attachment GA2 and GK2, check the bolt length limits shown above.

## Dimensional Drawings: DK 13150 and DK 13200 (for Metric series)

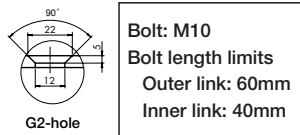
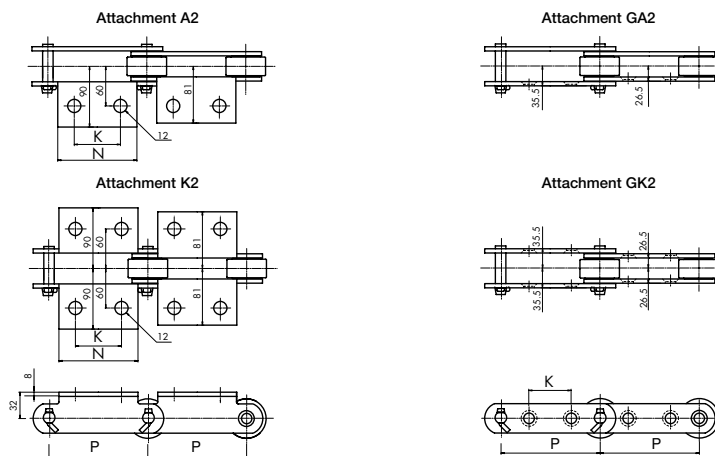
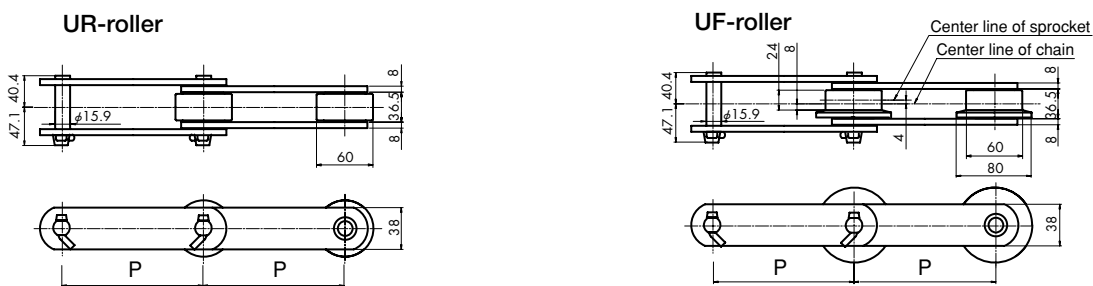

Chain No.		Avg. tensile strength kN (kgf)		Pitch P	Standard attachments									
Chain size	Roller type	Normal A,J	Heavy duty K,E		A1 · K1 K	A2 · K2 N	A3 · K3 N	SA2 · SK2 N	GA2 · GK2 K	G4 K Y B				
<b>DK 13150</b>	<b>UR,UF</b>	127 (13,000)	240 (24,500)	150	—	90	60	—	—	—	—	45	—	—
<b>DK 13200</b>	<b>UR,UF</b>			200	—	110	80	—	—	—	—	80	—	—

Chain No.		Combination of standard attachments and rollers						Approx. weight kg/m		Attachment weight (kg)				
Chain size	Roller type	A1 K1	A2 K2	A3 K3	SA2 SK2	GA2 GK2	G4	UR-roller	UF-roller	A2	A3	K2	K3	G4
<b>DK 13150</b>	<b>UR,UF</b>	—	UR,UF	—	—	UR,UF	—	10.9	11.6	0.39	—	0.78	—	—
<b>DK 13200</b>	<b>UR,UF</b>	—	UR,UF	—	—	UR,UF	—	9.3	9.8	0.48	—	0.96	—	—

Note: 1. The dimensions of the normal and heavy duty chains are the same, but heavy duty chains are made of high-strength and structural steel, and are suitable when higher safety rate, strength or wear resistance is required.  
2. With Attachment GA2 and GK2, check the bolt length limits shown above.

## Dimensional Drawings: DK 19200, DK 19250 and DK 19300 (for Metric series)

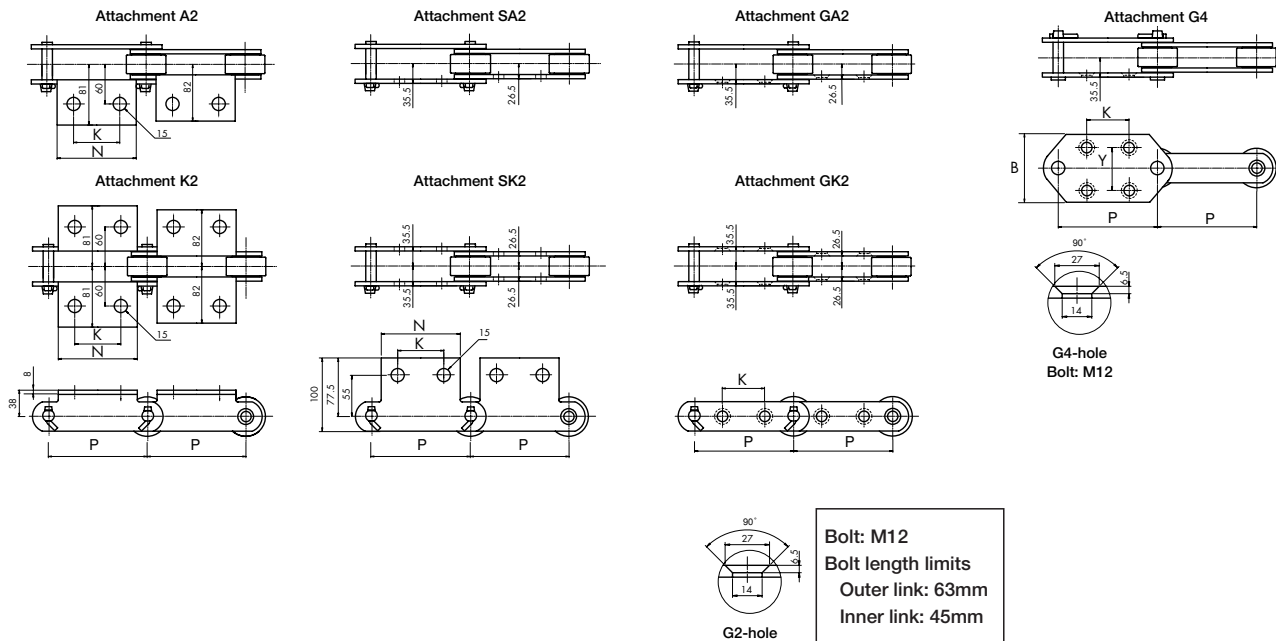
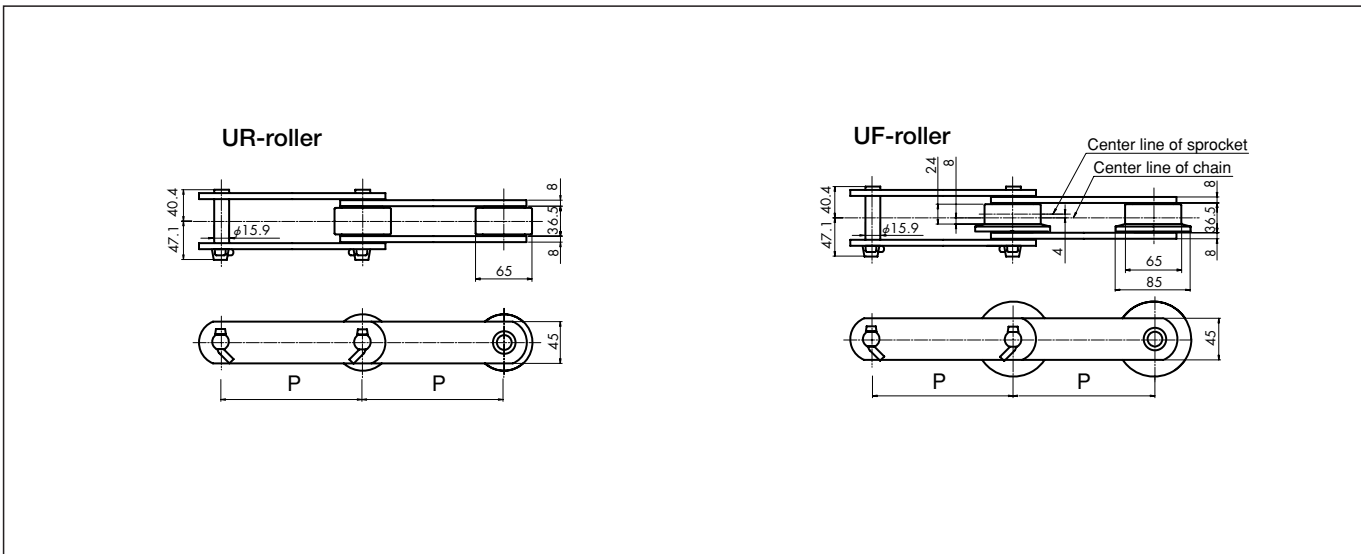

Chain No.		Avg. tensile strength kN (kgf)		Pitch P	Standard attachments										
Chain size	Roller type	Normal A,J	Heavy duty K,E		A1 · K1		A2 · K2		A3 · K3		SA2 · SK2		GA2 · GK2		G4
					N	K	N	K	N	K	N	K	K	Y	B
DK 19200	UR,UF	186 (19,000)	279 (28,500)	200	—	120	80	—	—	120	80	80	100	80	125
DK 19250	UR,UF			250	—	170	125	—	—	170	125	125	100	80	125
DK 19300	UR,UF			300	—	220	180	—	—	—	—	150	—	—	—

Chain No.		Combination of standard attachments and rollers						Approx. weight kg/m		Attachment weight (kg)				
Chain size	Roller type	A1 K1	A2 K2	A3 K3	SA2 SK2	GA2 GK2	G4	UR-roller	UF-roller	A2 SA2	A3	K2 SK2	K3	G4
DK 19200	UR,UF	—	UR,UF	—	UR	UR,UF	UR,UF	11.5	12.1	0.49	—	0.98	—	0.95
DK 19250	UR,UF	—	UR,UF	—	UR	UR,UF	UR,UF	10.3	10.8	0.69	—	1.38	—	1.20
DK 19300	UR,UF	—	UR,UF	—	—	UR,UF	—	9.5	10.0	0.89	—	1.78	—	—

Note: 1. The dimensions of the normal and heavy duty chains are the same, but heavy duty chains are made of high-strength and structural steel, and are suitable when higher safety rate, strength or wear resistance is required.  
 2. With Attachment GA2 and GK2, check the bolt length limits shown above.

DK Conveyor Chains  
Fixing-proof Roller

## Dimensional Drawings: DK 25200, DK 25250 and DK 25300 (for Metric series)

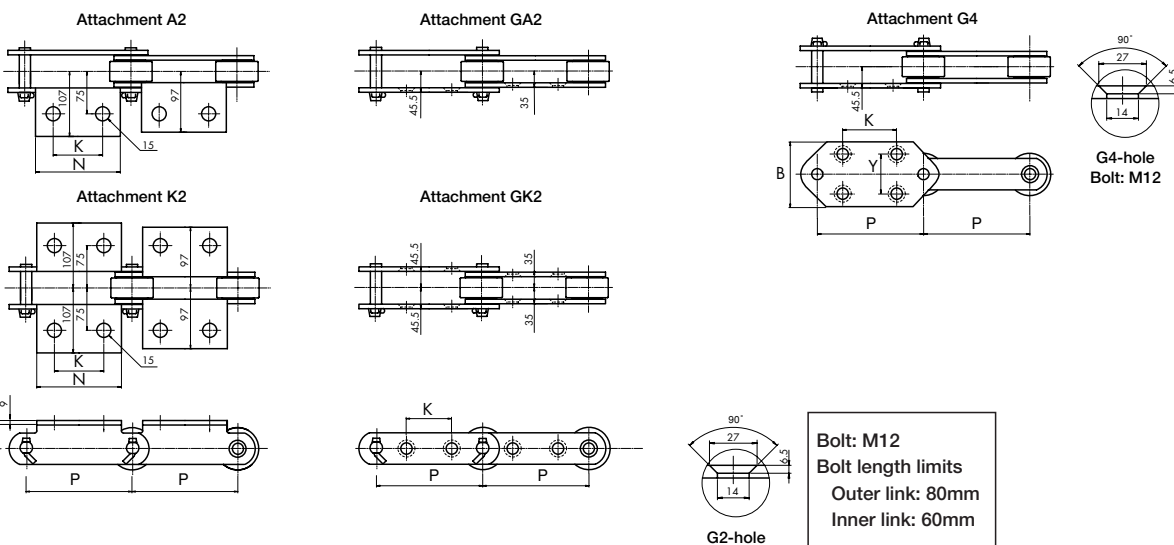
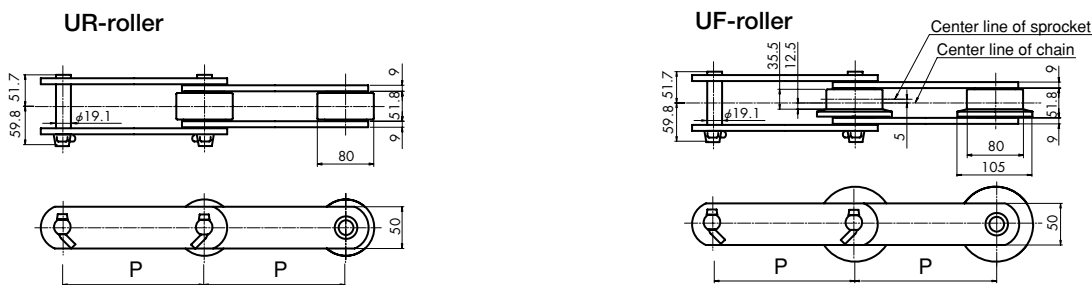

Chain No.		Avg. tensile strength kN (kgf)		Pitch	Standard attachments											
Chain size	Roller type	Normal A,J	Heavy duty K,E	P	A1 · K1		A2 · K2		A3 · K3		SA2 · SK2		GA2 · GK2		G4	
					K	N	K	N	K	N	K	K	K	Y	B	
<b>DK 25200</b>	<b>UR,UF</b>	245 (25,000)	392 (40,000)	200	—	120	80	—	—	—	—	70	100	80	125	
<b>DK 25250</b>	<b>UR,UF</b>			250	—	170	125	—	—	—	—	110	140	80	125	
<b>DK 25300</b>	<b>UR,UF</b>			300	—	220	180	—	—	—	—	150	—	—	—	

Chain No.		Combination of standard attachments and rollers						Approx. weight kg/m		Attachment weight (kg)				
Chain size	Roller type	A1 K1	A2 K2	A3 K3	SA2 SK2	GA2 GK2	G4	UR-roller	UF-roller	A2	A3	K2	K3	G4
<b>DK 25200</b>	<b>UR,UF</b>	—	UR,UF	—	—	UR,UF	UR,UF	18.2	19.5	0.63	—	1.26	—	1.05
<b>DK 25250</b>	<b>UR,UF</b>	—	UR,UF	—	—	UR,UF	UR,UF	15.9	17.0	0.90	—	1.80	—	1.32
<b>DK 25300</b>	<b>UR,UF</b>	—	UR,UF	—	—	UR,UF	—	14.5	15.3	1.16	—	2.32	—	—

Note: 1. The dimensions of the normal and heavy duty chains are the same, but heavy duty chains are made of high-strength and structural steel, and are suitable when higher safety rate, strength or wear resistance is required.  
2. With Attachment GA2 and GK2, check the bolt length limits shown above.

# Dimensional Drawings: DK 32200, DK 32250, DK 32300 and DK 32450 (for Metric series)

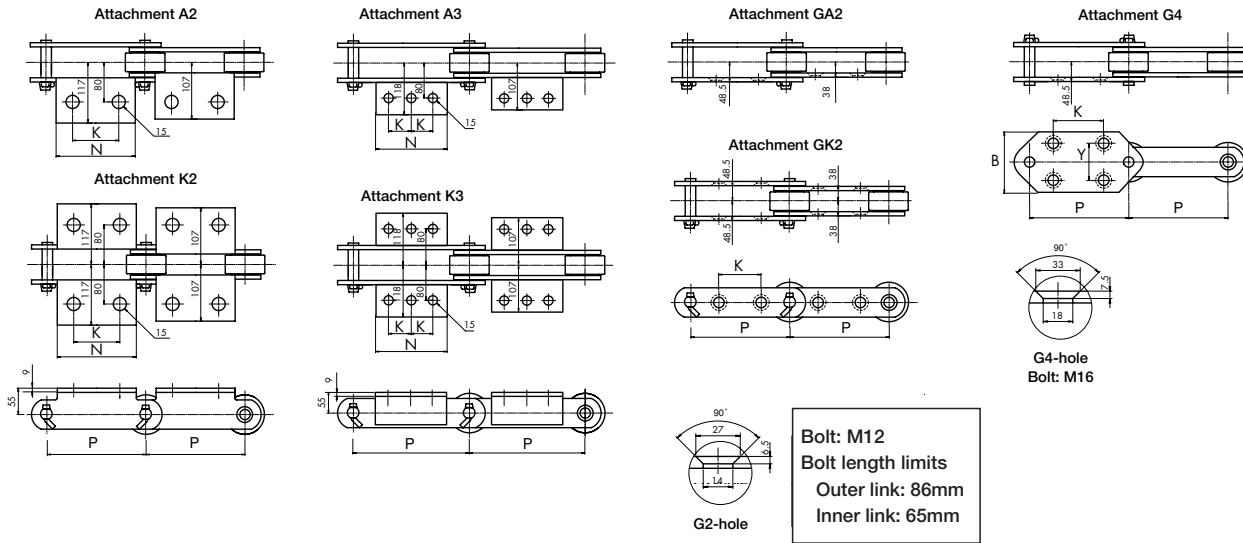
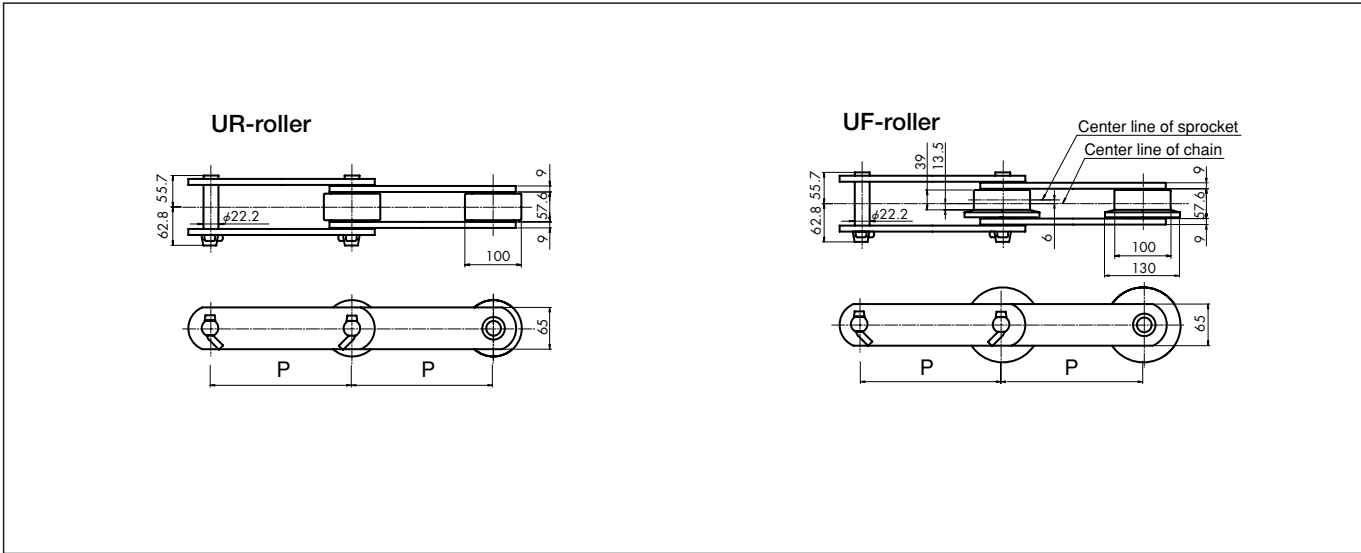

Chain No.		Avg. tensile strength kN (kgf)		Pitch	Standard attachments													
Chain size	Roller type	Normal A,J	Heavy duty K,E	P	A1 · K1		A2 · K2		A3 · K3		SA2 · SK2		GA2 · GK2		G4			
					N	K	N	K	N	K	N	K	K	Y	B			
DK 32200	UR,UF	313 (32,000)	500 (51,000)	200	—	120	80	—	—	—	—	—	70(40)	100	80	125		
DK 32250	UR,UF			250	—	170	125	—	—	—	—	—	—	110(90)	140	100	150	
DK 32300	UR,UF			300	—	220	180	—	—	—	—	—	—	—	140	170	100	150
DK 32450	UR,UF			450	—	330	280	330	140	—	—	—	—	—	220	—	—	—

Chain No.		Combination of standard attachments and rollers						Approx. weight kg/m		Attachment weight (kg)				
Chain size	Roller type	A1 K1	A2 K2	A3 K3	SA2 SK2	GA2 GK2	G4	UR-roller	UF-roller	A2	A3	K2	K3	G4
DK 32200	UR,UF	—	UR,UF	—	—	UR,UF	UR,UF	28.2	30.2	0.72	—	1.44	—	0.91
DK 32250	UR,UF	—	UR,UF	—	—	UR,UF	UR,UF	24.6	26.2	1.01	—	2.02	—	1.48
DK 32300	UR,UF	—	UR,UF	—	—	UR,UF	UR,UF	22.0	23.4	1.31	—	2.62	—	1.78
DK 32450	UR,UF	—	UR,UF	UR,UF	—	UR,UF	—	17.8	18.7	—	1.97	—	3.97	—

Note: 1. The dimensions of the normal and heavy duty chains are the same, but heavy duty chains are made of high-strength and structural steel, and are suitable when higher safety rate, strength or wear resistance is required.  
 2. K values in ( ) for Attachment GA2 and GK2 are for Roller UF.  
 3. With Attachment GA2 and GK2, check the bolt length limits shown above.  
 4. Attachment A3 and K3 are angle welding attachments.

DK Conveyor Chains  
Fixing-proof Roller



## Dimensional Drawings: DK 50250, DK 50300, DK 50450 and DK 50600 (for Metric series)

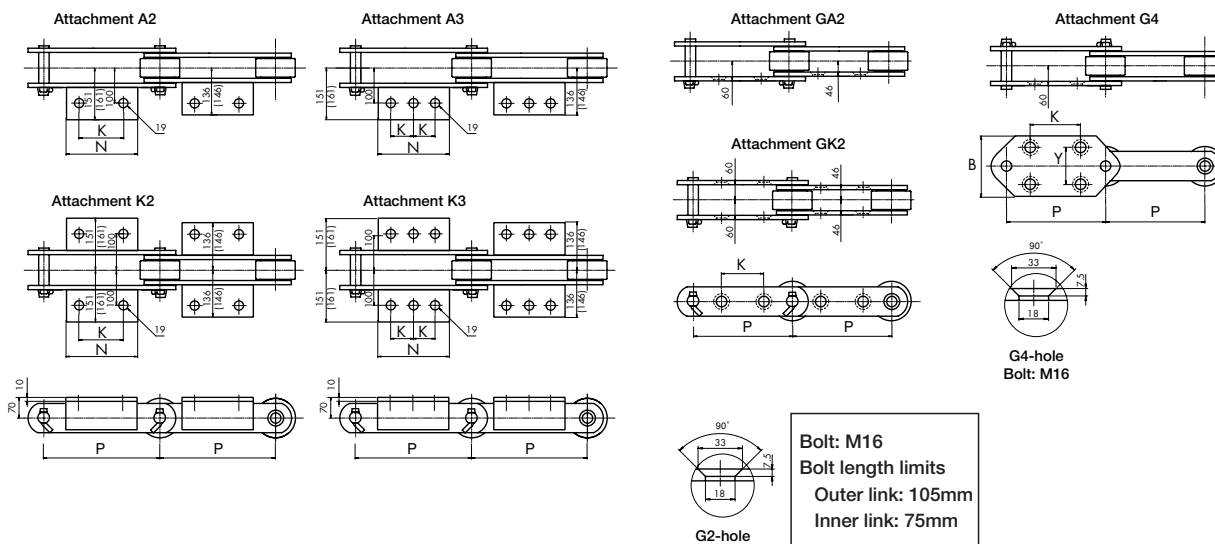
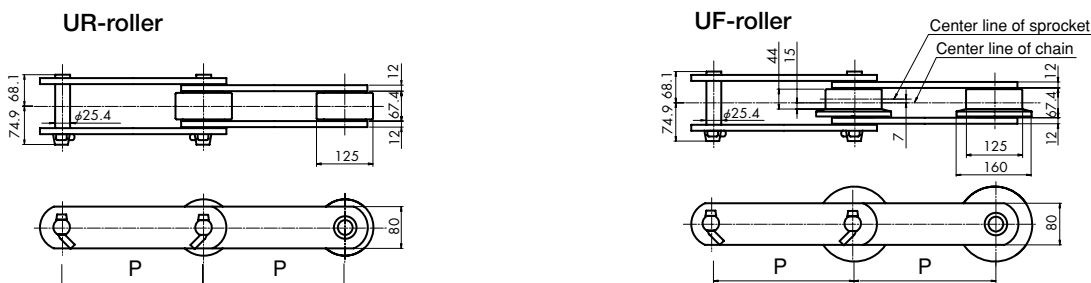

Chain No.		Avg. tensile strength kN (kgf)		Pitch	Standard attachments										
Chain size	Roller type	Normal A,J	Heavy duty K,E	P	A1 · K1 N	A2 · K2 N	A3 · K3 N	SA2 · SK2 N	GA2 · GK2 K	G4					
										K	Y	B			
DK 50250	UR,UF	490 (50,000)	686 (70,000)	250	—	170	125	—	—	—	90 (55)	140	100	150	
DK 50300	UR,UF			300	—	220	180	—	—	—	140(105)	170	100	150	
DK 50450	UR,UF			450	—	—	—	330	140	—	—	220	—	—	—
DK 50600	UR,UF			600	—	—	—	410	180	—	—	300	—	—	—

Chain No.		Combination of standard attachments and rollers						Approx. weight kg/m		Attachment weight (kg)				
Chain size	Roller type	A1 K1	A2 K2	A3 K3	SA2 SK2	GA2 GK2	G4	UR-roller	UF-roller	A2	A3	K2	K3	G4
DK 50250	UR,UF	—	UR,UF	—	—	UR,UF	UR,UF	42.7	45.8	2.26	—	4.52	—	1.74
DK 50300	UR,UF	—	UR,UF	—	—	UR,UF	UR,UF	38.0	40.4	2.93	—	5.86	—	2.07
DK 50450	UR,UF	—	—	UR,UF	—	UR,UF	—	30.3	31.9	—	4.39	—	8.78	—
DK 50600	UR,UF	—	—	UR,UF	—	UR,UF	—	26.7	28.0	—	5.45	—	10.90	—

- Note: 1. The dimensions of the normal and heavy duty chains are the same, but heavy duty chains are made of high-strength and structural steel, and are suitable when higher safety rate, strength or wear resistance is required.  
 2. K values in ( ) for Attachment GA2 and GK2 are for Roller UF.  
 3. With Attachment GA2 and GK2, check the bolt length limits shown above.  
 4. Attachment A3 and K3 are angle welding attachments.

# Dimensional Drawings: DK 65300 and DK 65450 (for Metric series)

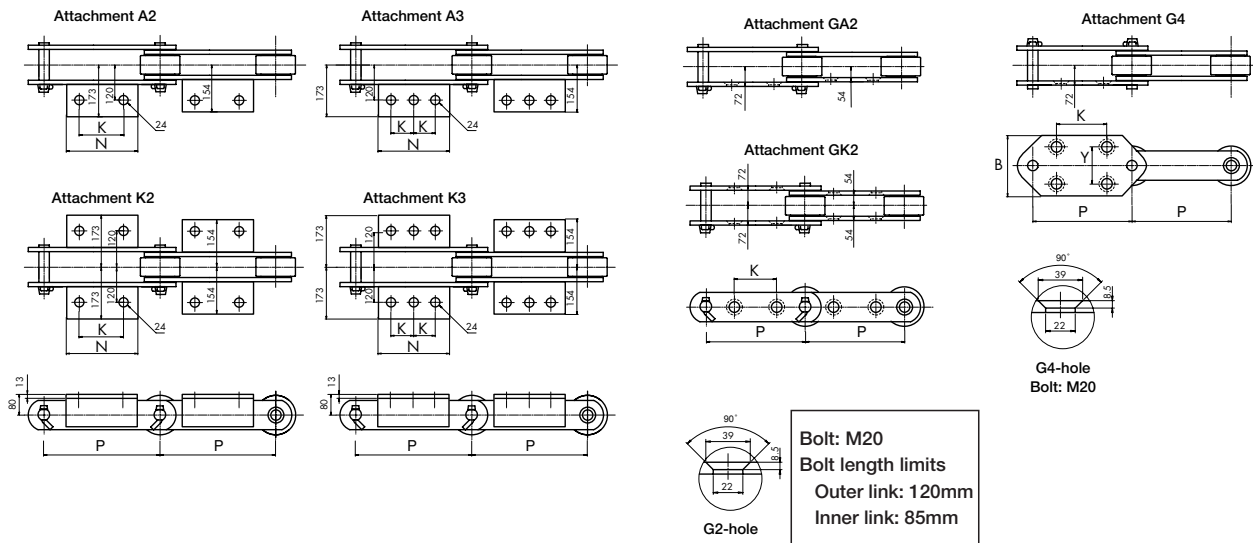
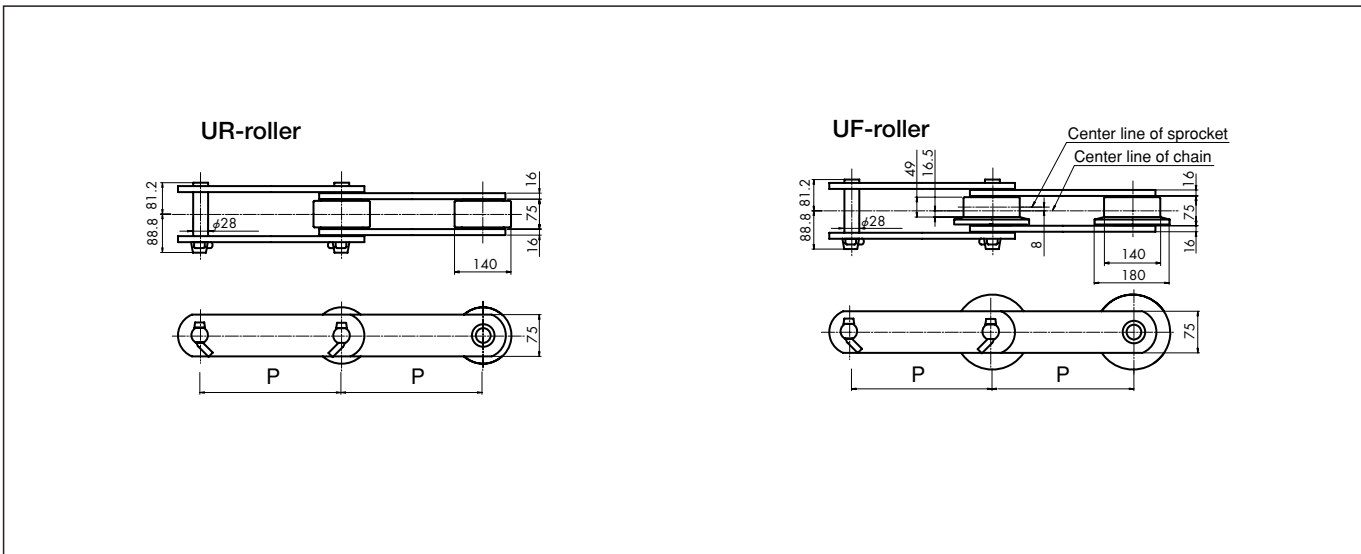

Chain No.		Avg. tensile strength kN (kgf)		Pitch	Standard attachments										
Chain size	Roller type	Normal <b>A,J</b>	Heavy duty <b>K,E</b>	P	A1 · K1		A2 · K2		A3 · K3		SA2 · SK2		G4		
					N	N	K	N	K	N	K	K	Y	B	
<b>DK 65300</b>	<b>UR,UF</b>	637	882	300	—	180	130	—	—	—	—	120(80)	170	100	160
<b>DK 65450</b>	<b>UR,UF</b>	(65,000)	(90,000)	450	—	—	—	330	140	—	—	200	—	—	—

Chain No.		Combination of standard attachments and rollers						Approx. weight kg/m		Attachment weight (kg)				
Chain size	Roller type	A1	A2	A3	SA2	GA2	G4	UR-roller	UF-roller	A2	A3	K2	K3	G4
		K1	K2	K3	SK2	GK2								
<b>DK 65300</b>	<b>UR,UF</b>	—	UR,UF	—	—	UR,UF	UR,UF	47.8	51.2	3.44	—	6.88	—	2.81
<b>DK 65450</b>	<b>UR,UF</b>	—	—	UR,UF	—	UR,UF	—	37.0	39.3	—	6.30	—	12.6	—

- Note: 1. The dimensions of the normal and heavy duty chains are the same, but heavy duty chains are made of high-strength and structural steel, and are suitable when higher safety rate, strength or wear resistance is required.  
 2. K values in ( ) for Attachment GA2 and GK2 are for Roller UF.  
 3. With Attachment GA2 and GK2, check the bolt length limits shown above.  
 4. Attachment A3 and K3 are angle welding attachments.

DK Conveyor Chains  
Fixing-proof Roller

## Dimensional Drawings: DK 05101 (for Inch series)

UR-roller

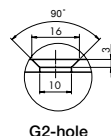
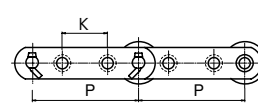
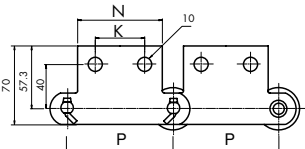
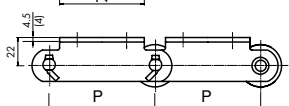
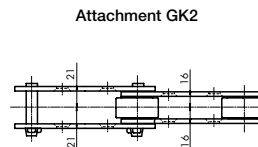
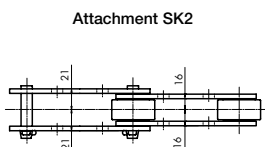
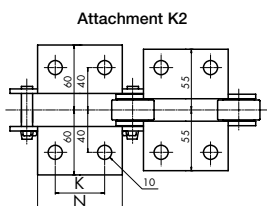
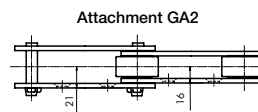
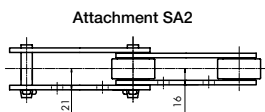
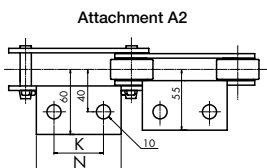
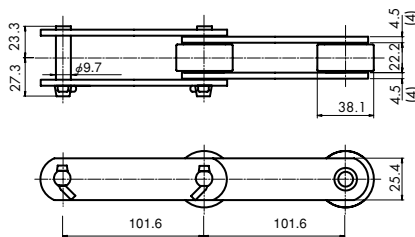

**Bolt: M8**  
**Bolt length limits**  
 Outer link: 32mm  
 Inner link: 25mm

Chain No.		Avg. tensile strength kN (kgf)		Pitch	Standard attachments											
Chain size	Roller type	Normal	Heavy duty	P	A1 · K1		A2 · K2		A3 · K3		SA2 · SK2		GA2 · GK2		G4	
		A,J	K,E		N	N	K	N	K	N	K	K	K	Y	B	
<b>DK 05101</b>	<b>UR</b>	53.9 (5,500)	98 (10,000)	101.6	—	70	40	—	—	70	40	45	—	—	—	

Chain No.		Combination of standard attachments and rollers						Approx. weight kg/m	Attachment weight (kg)				
Chain size	Roller type	A1	A2	A3	SA2	GA2	G4	UR-roller	A2	A3	K2	K3	G4
		K1	K2	K3	SK2	GK2	SK2		SA2	SK2	SK2	SK2	SK2
<b>DK 05101</b>	<b>UR</b>	—	UR	—	UR	UR	—	4.1	0.72	—	0.24	—	—

Note: 1. Values in ( ) for the plate thickness are for the stainless steel chains. Values for plate thickness without ( ) apply to all types.  
 2. The dimensions of the normal and heavy duty chains are the same, but heavy duty chains are made of high-strength and structural steel, and are suitable when higher safety rate, strength or wear resistance is required.  
 3. With Attachment GA2 and GK2, check the bolt length limits shown above.

# Dimensional Drawings: DK 08101 (for Inch series)

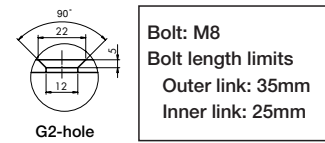
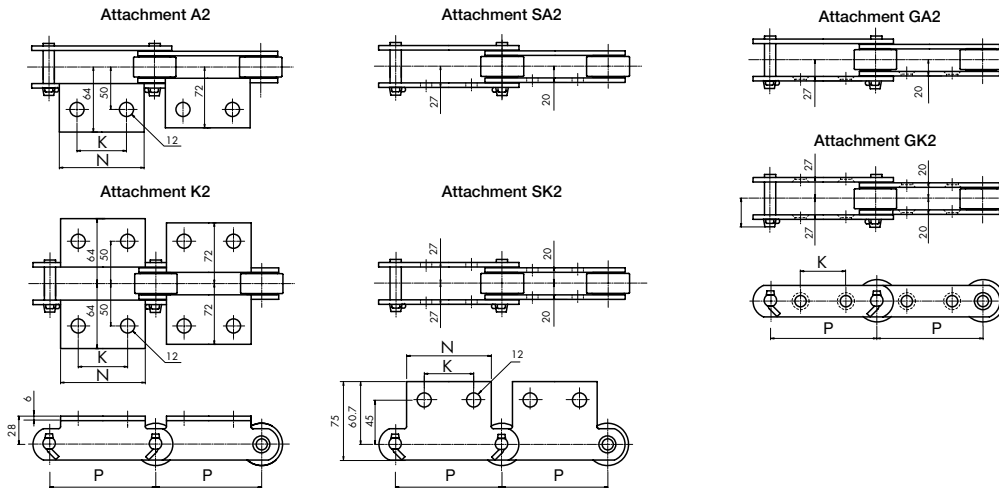
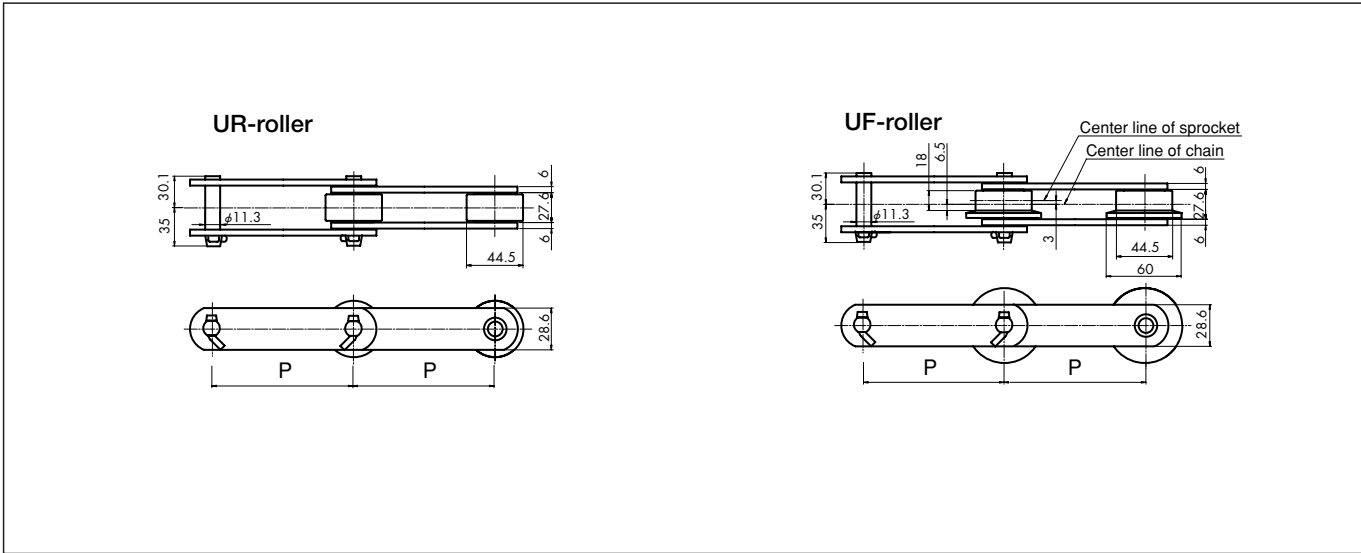

Chain No.		Avg. tensile strength kN (kgf)		Pitch	Standard attachments											
Chain size	Roller type	Normal <b>A,J</b>	Heavy duty <b>K,E</b>	P	A1 · K1		A2 · K2		A3 · K3		SA2 · SK2		GA2 · GK2		G4	
					N	N	K	N	K	N	K	K	K	Y	B	
<b>DK 08101</b>	<b>UR,UF</b>	78.4 (8,000)	142 (14,500)	101.6	—	70	40	—	—	70	40	35	—	—	—	

Chain No.		Combination of standard attachments and rollers						Approx. weight kg/m		Attachment weight (kg)				
Chain size	Roller type	A1	A2	A3	SA2	GA2	G4	UR-roller	UF-roller	A1,A2	A3	K1,K2	K3	G4
		K1	K2	K3	SK2	GK2	SA2			SK2	SA2	SK2		
<b>DK 08101</b>	<b>UR,UF</b>	—	UR,UF	—	UR,UF	UR,UF	—	6.9	7.3	0.20	—	0.40	—	—

Note: 1. The dimensions of the normal and heavy duty chains are the same, but heavy duty chains are made of high-strength and structural steel, and are suitable when higher safety rate, strength or wear resistance is required.  
 2. With Attachment GA2 and GK2, check the bolt length limits shown above.

DK Conveyor Chains  
Fixing-proof Roller

## Dimensional Drawings: DK 09101 (for Inch series)

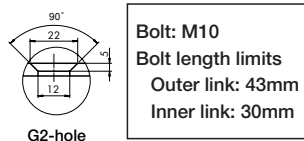
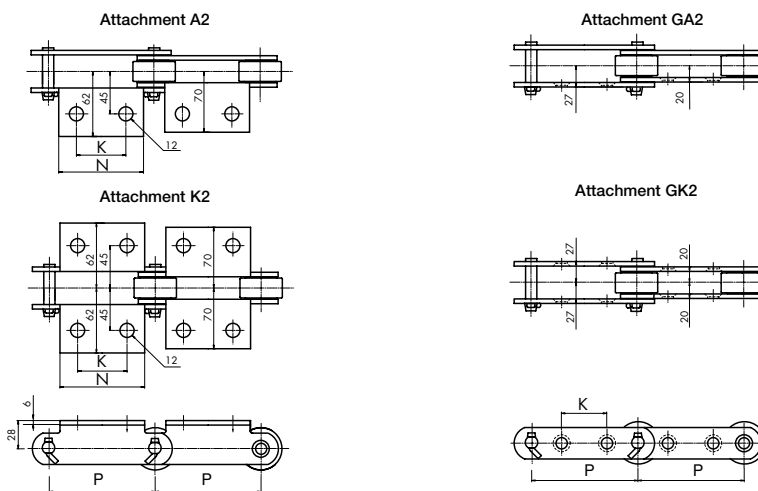
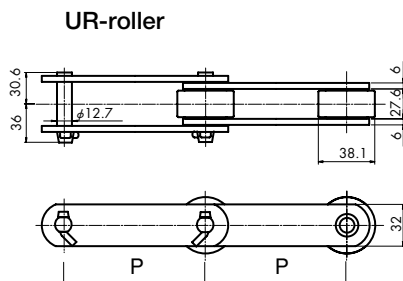

Chain No.		Avg. tensile strength kN (kgf)		Pitch	Standard attachments											
Chain size	Roller type	Normal	Heavy duty	P	A1 · K1		A2 · K2		A3 · K3		SA2 · SK2		GA2 · GK2		G4	
		A,J	K,E		N	N	K	N	K	N	K	K	K	Y	B	
<b>DK 09101</b>	<b>UR</b>	88.2 (9,000)	156 (16,000)	101.6	—	70	40	—	—	—	—	40	—	—	—	

Chain No.		Combination of standard attachments and rollers						Approx. weight kg/m	Attachment weight (kg)				
Chain size	Roller type	A1	A2	A3	SA2	GA2	G4	UR-roller	A2	A3	K2	K3	G4
		K1	K2	K3	SK2	GK2							
<b>DK 09101</b>	<b>UR</b>	—	UR	—	—	UR	—	6.4	0.19	—	0.38	—	—

Note: 1. The dimensions of the normal and heavy duty chains are the same, but heavy duty chains are made of high-strength and structural steel, and are suitable when higher safety rate, strength or wear resistance is required.  
2. With Attachment GA2 and GK2, check the bolt length limits shown above.

# Dimensional Drawings: DK 11152 (for Inch series)

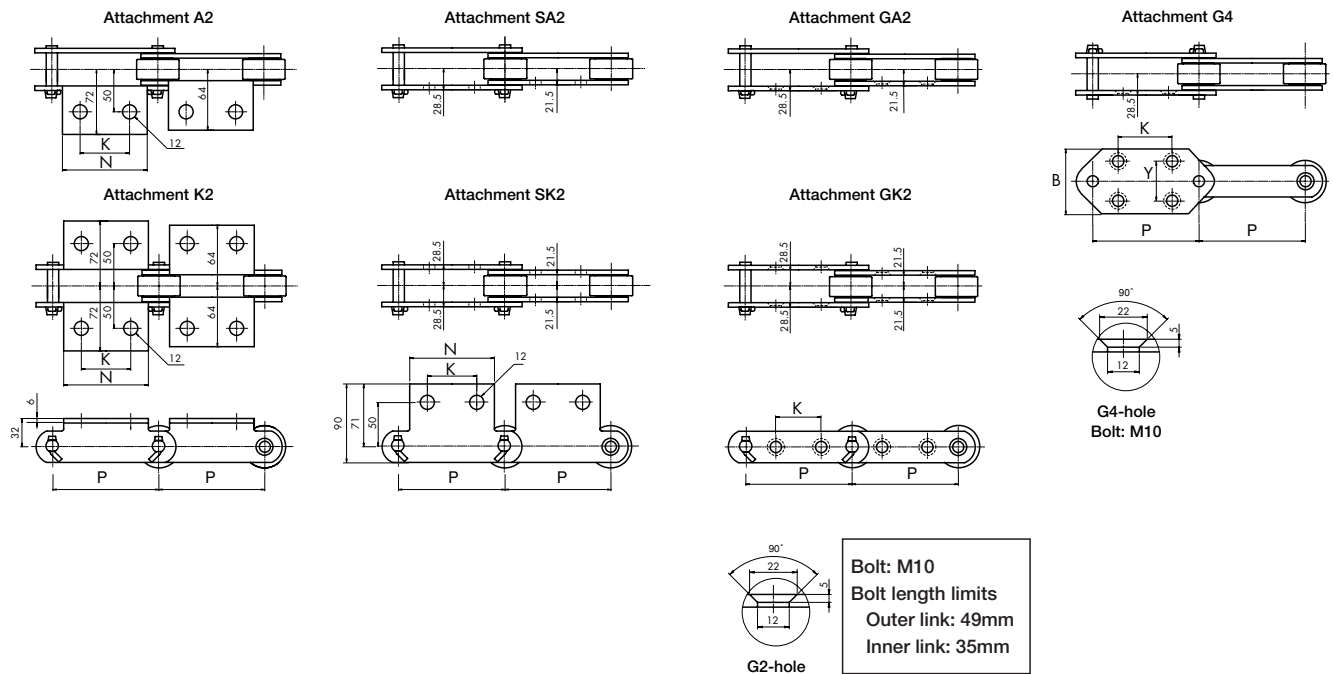
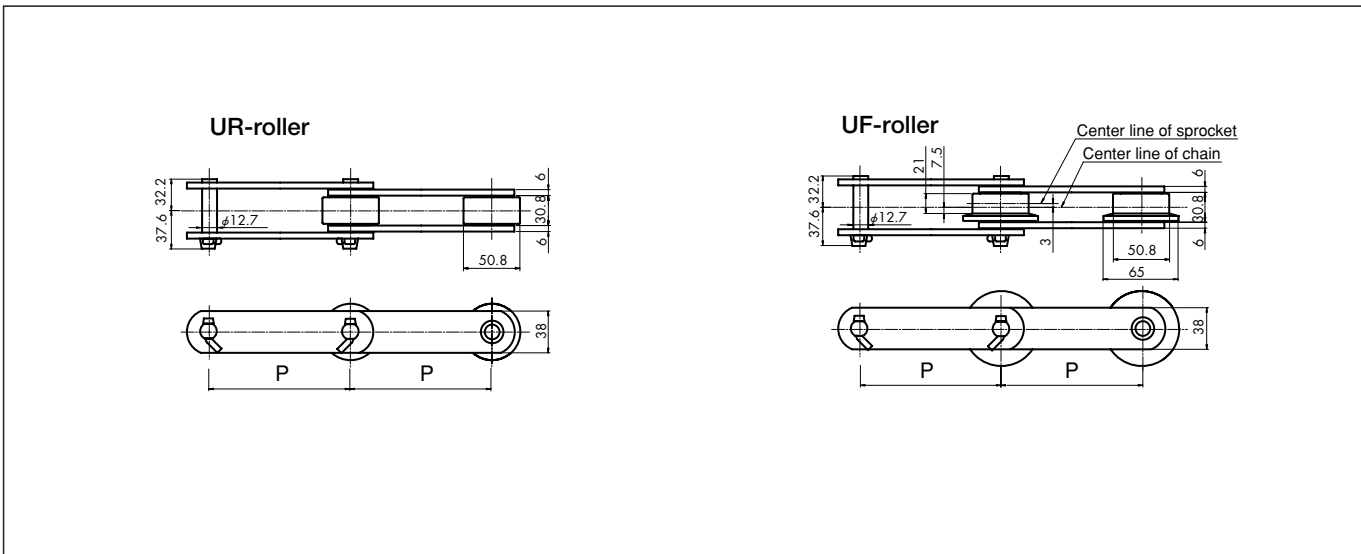

Chain No.		Avg. tensile strength kN (kgf)		Pitch	Standard attachments												
Chain size	Roller type	Normal <b>A,J</b>	Heavy duty <b>K,E</b>	P	A1 · K1		A2 · K2		A3 · K3		SA2 · SK2		GA2 · GK2		G4		
					N	N	K	N	K	N	K	K	K	Y	B		
<b>DK 11152</b>	<b>UR,UF</b>	112 (11,500)	171 (17,500)	152.4	—	90	60	—	—	90	60	60	75	70	100		

Chain No.		Combination of standard attachments and rollers						Approx. weight kg/m		Attachment weight (kg)				
Chain size	Roller type	A1	A2	A3	SA2	GA2	G4	UR-roller	UF-roller	A2	A3	K2	K3	G4
		K1	K2	K3	SK2	GK2								
<b>DK 11152</b>	<b>UR,UF</b>	—	UR,UF	—	UR	UR,UF	UR,UF	7.4	7.9	0.22	—	0.44	—	—

Note: 1. The dimensions of the normal and heavy duty chains are the same, but heavy duty chains are made of high-strength and structural steel, and are suitable when higher safety rate, strength or wear resistance is required.  
 2. With Attachment GA2 and GK2, check the bolt length limits shown above.

## Dimensional Drawings: DK 13101 (for Inch series)

UR-roller

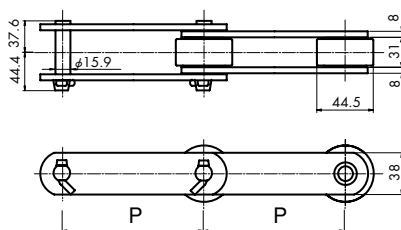

Attachment A2

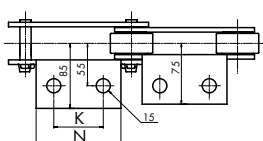

Attachment SA2

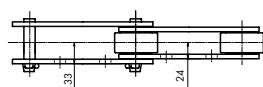

Attachment K2

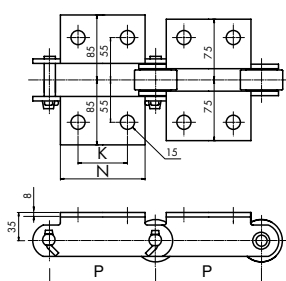

Attachment SK2

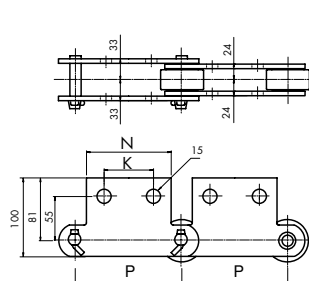

Chain No.		Avg. tensile strength kN (kgf)		Pitch	Standard attachments											
Chain size	Roller type	Normal	Heavy duty	P	A1 · K1		A2 · K2		A3 · K3		SA2 · SK2		GA2 · GK2		G4	
		A,J	K,E		N	N	K	N	K	N	K	K	K	Y	B	
<b>DK 13101</b>	<b>UR</b>	127 (13,000)	240 (24,500)	101.6	—	80	40	—	—	80	40	—	—	—	—	

Chain No.		Combination of standard attachments and rollers						Approx. weight kg/m	Attachment weight (kg)				
Chain size	Roller type	A1	A2	A3	SA2	GA2	G4	UR-roller	A2	A3	K2	K3	G4
		K1	K2	K3	SK2	GK2	SA2		SK2	SK2	SK2	SK2	SK2
<b>DK 13101</b>	<b>UR</b>	—	UR	—	UR	—	—	10.3	0.31	—	0.62	—	—

Note: The dimensions of the normal and heavy duty chains are the same, but heavy duty chains are made of high-strength and structural steel, and are suitable when higher safety rate, strength or wear resistance is required.



# Dimensional Drawings: DK 19152 (for Inch series)

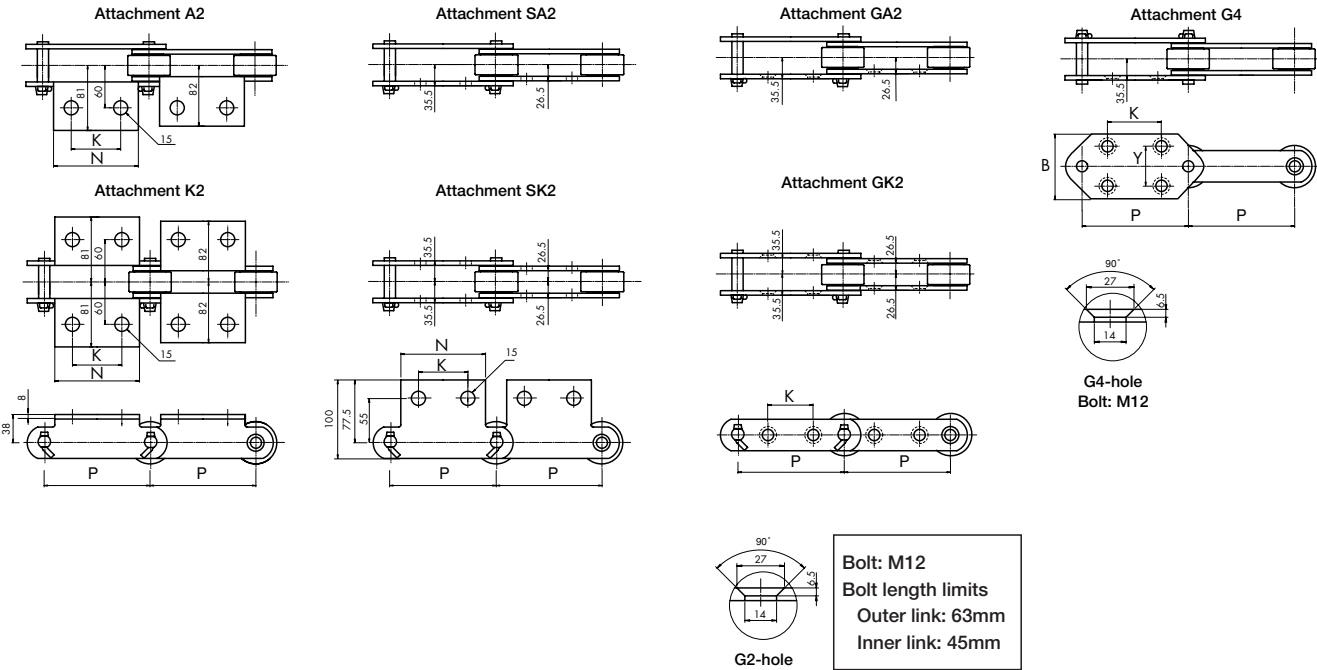
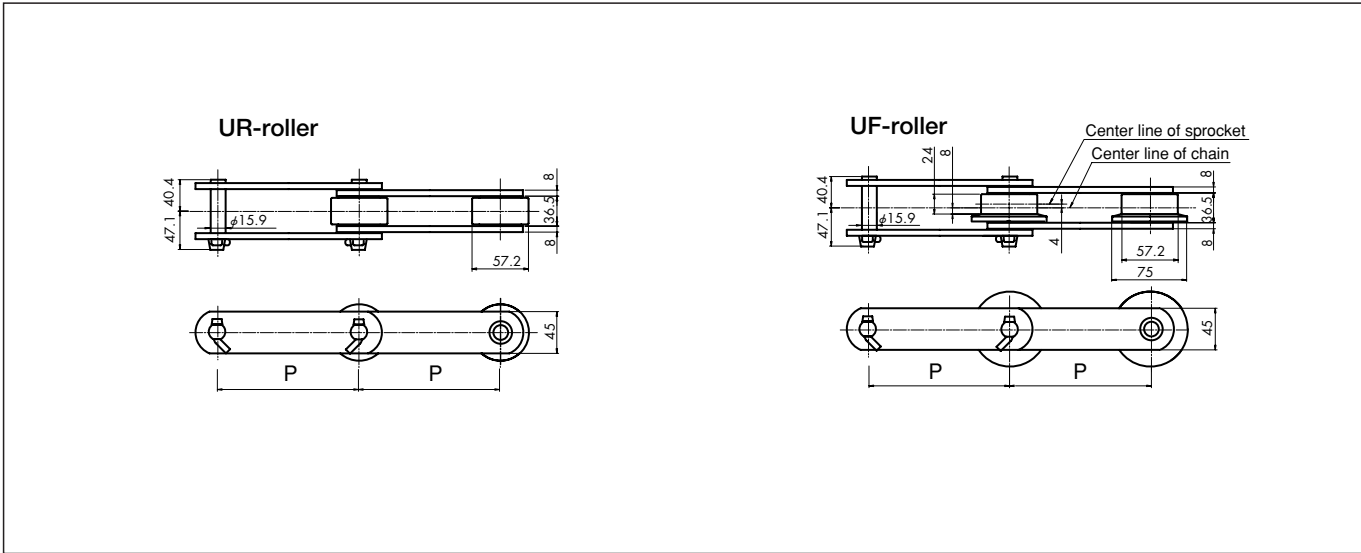

Chain No.		Avg. tensile strength kN (kgf)		Pitch	Standard attachments											
Chain size	Roller type	Normal <b>A,J</b>	Heavy duty <b>K,E</b>	P	A1 · K1		A2 · K2		A3 · K3		SA2 · SK2		GA2 · GK2		G4	
					N	N	K	N	K	N	K	K	K	Y	B	
<b>DK 19152</b>	<b>UR,UF</b>	186 (19,000)	279 (28,500)	152.4	—	100	60	—	—	100	60	50	75	70	110	

Chain No.		Combination of standard attachments and rollers						Approx. weight kg/m		Attachment weight (kg)				
Chain size	Roller type	A1	A2	A3	SA2	GA2	G4	UR-roller	UF-roller	A2	A3	K2	K3	G4
		K1	K2	K3	SK2	GK2	SA2			SK2	K3	G4		
<b>DK 19152</b>	<b>UR,UF</b>	—	UR,UF	—	UR	UR,UF	UR,UF	11.8	12.2	0.41	—	0.82	—	0.60

Note: 1. The dimensions of the normal and heavy duty chains are the same, but heavy duty chains are made of high-strength and structural steel, and are suitable when higher safety rate, strength or wear resistance is required.  
2. With Attachment GA2 and GK2, check the bolt length limits shown above.

DK Conveyor Chains  
Fixing-proof Roller

## Dimensional Drawings: DK 25152 (for Inch series)

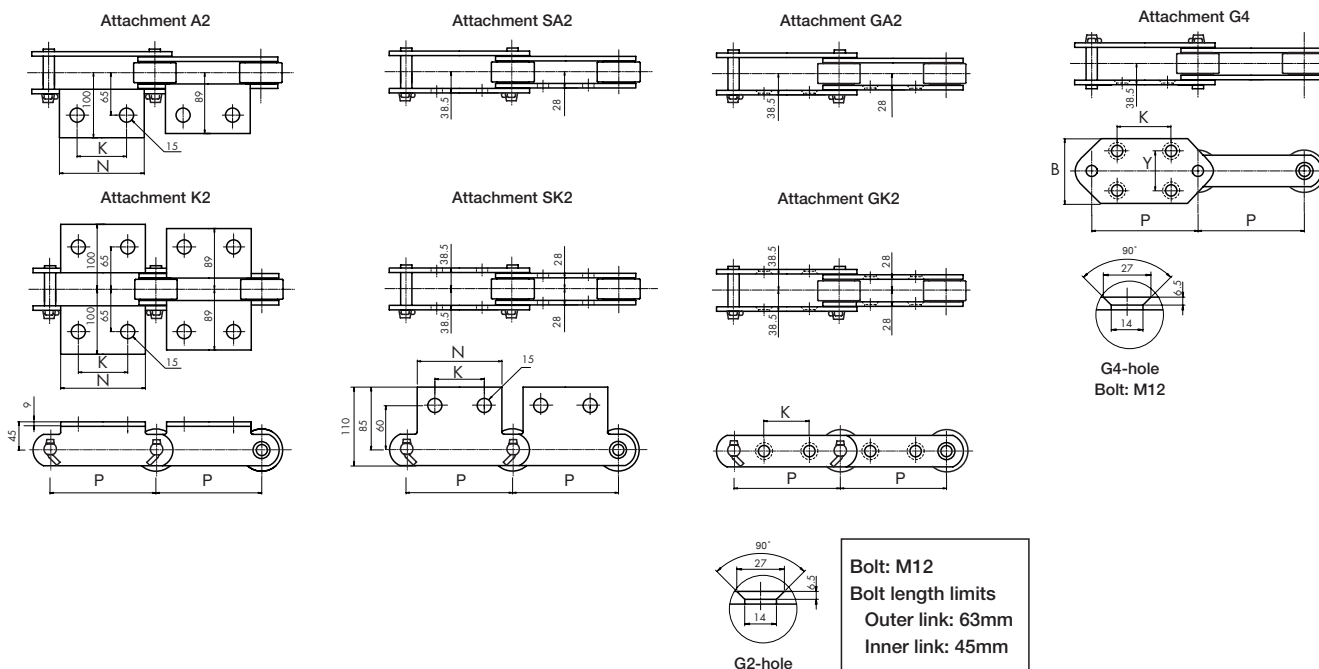
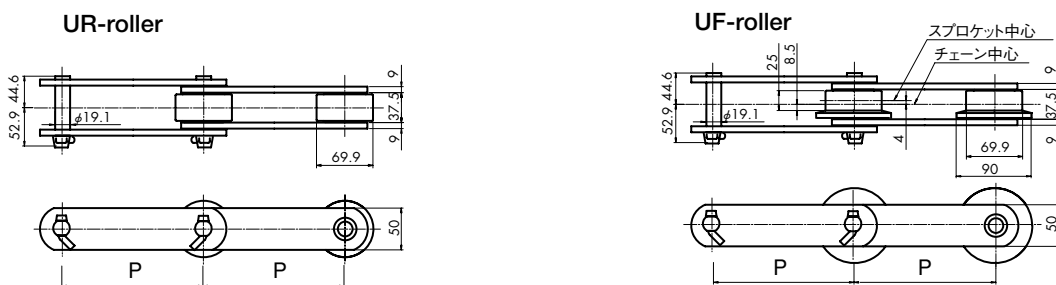

Chain No.		Avg. tensile strength kN (kgf)		Pitch	Standard attachments											
Chain size	Roller type	Normal <b>A,J</b>	Heavy duty <b>K,E</b>	P	A1 · K1		A2 · K2		A3 · K3		SA2 · SK2		GA2 · GK2		G4	
					N	N	K	N	K	N	K	K	K	Y	B	
<b>DK 25152</b>	<b>UR,UF</b>	245 (25,000)	392 (40,000)	152.4	—	100	60	—	—	100	60	55(35)	75	70	125	

Chain No.		Combination of standard attachments and rollers						Approx. weight kg/m		Attachment weight (kg)				
Chain size	Roller type	A1 K1	A2 K2	A3 K3	SA2 SK2	GA2 GK2	G4	UR-roller	UF-roller	A2	A3	K2	K3	G4
										SA2	—	SK2	—	—
<b>DK 25152</b>	<b>UR,UF</b>	—	UR,UF	—	UR	UR,UF	UR,UF	11.8	12.2	0.53	—	1.06	—	0.79

Note: 1. The dimensions of the normal and heavy duty chains are the same, but heavy duty chains are made of high-strength and structural steel, and are suitable when higher safety rate, strength or wear resistance is required.  
 2. K values in ( ) for Attachment GA2 and GK2 are for Roller UF.  
 3. With Attachment GA2 and GK2, check the bolt length limits shown above.

## Bearing Assembled Roller Conveyor Chain

This chain has bearings built into the rollers. A chain smaller than a regular conveyor can be selected because the drive loss of the chain is small due to small rolling friction of the rollers, and the allowable load of the rollers is large.

- The chain body is identical to Standard Conveyor Chains with Roller R and Roller F.
- Sprockets for Standard Conveyor Chains can be used.
- Dimensions for attachments are also identical to those of Standard Conveyor Chains.
- Coefficient of rolling friction:  $f=0.035\sim0.050$

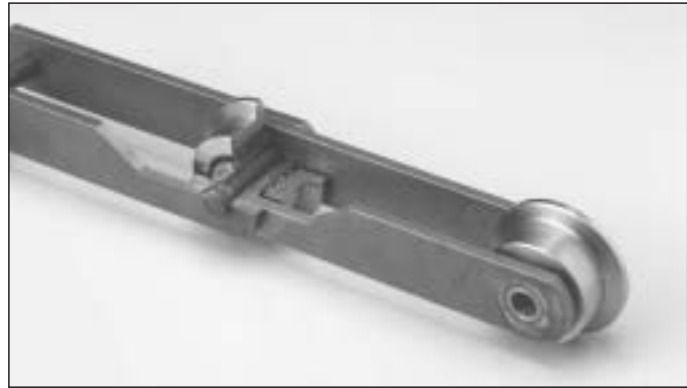

## Application examples

- Conveyors with extensive center distance.
- Conveyors that need to have smooth movement and high precision
- Assembly line of automobiles

Slat conveyors that are provided with slats (duplex chain) on both sides are used in assembling, finishing and inspection lines of automobiles. Since their center distances are very long and high accuracy and smooth feeding are required, bearing assembled roller conveyor chains are used.



## Table of applicable attachments

Chain No.	Standard attachment											
	A1	A2	A3	K1	K2	K3	SA1	SA2	SK1	SK2	GA2	GK2
DK 11100	×	○	×	×	○	×	×	○	×	○	○	○
DK 11125	×	○	×	×	○	×	×	×	×	×	○	○
DK 11150	×	○	×	×	○	×	×	○	×	○	○	○
DK 11200	×	○	×	×	○	×	×	×	×	×	○	○
DK 13150	×	○	×	×	○	×	×	×	×	×	○	○
DK 13200	×	○	×	×	○	×	×	×	×	×	○	○
DK 19200	×	○	×	×	○	×	×	○	×	○	○	○
DK 19250	×	○	×	×	○	×	×	○	×	○	○	○
DK 19300	×	○	×	×	○	×	×	×	×	×	○	○
DK 25200	×	○	×	×	○	×	×	×	×	×	○	○
DK 25250	×	○	×	×	○	×	×	×	×	×	○	○
DK 25300	×	○	×	×	○	×	×	×	×	×	○	○
DK 32200	×	○	×	×	○	×	×	×	×	×	○	○
DK 32250	×	○	×	×	○	×	×	×	×	×	○	○
DK 32300	×	○	×	×	○	×	×	×	×	×	○	○
DK 32450	×	○	×	×	○	×	×	×	×	×	○	○
DK 50250	×	○	×	×	○	×	×	×	×	×	○	○
DK 50300	×	○	×	×	○	×	×	×	×	×	○	○
DK 50450	×	×	○	×	×	○	×	×	×	×	○	○
DK 11152	×	○	×	×	○	×	×	○	×	○	○	○
DK 19152	×	○	×	×	○	×	×	○	×	○	○	○
DK 25152	×	○	×	×	○	×	×	○	×	○	○	○

○ : Standard product      × : Nonstandard product  
 Note: Consult us for manufacturing nonstandard products.

DK Conveyor Chains  
Bearing Assembled Roller Type Conveyor Chain

## Dimensional Drawings: DK 1100, DK 1125, DK 1150, and DK 11200 (for Metric series)

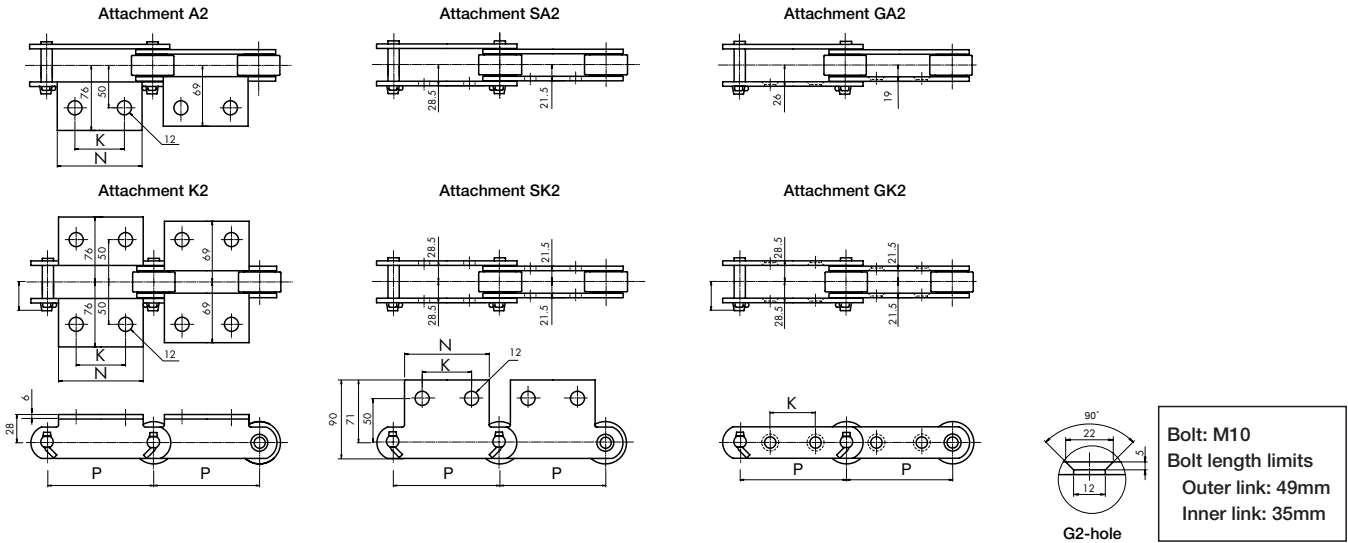
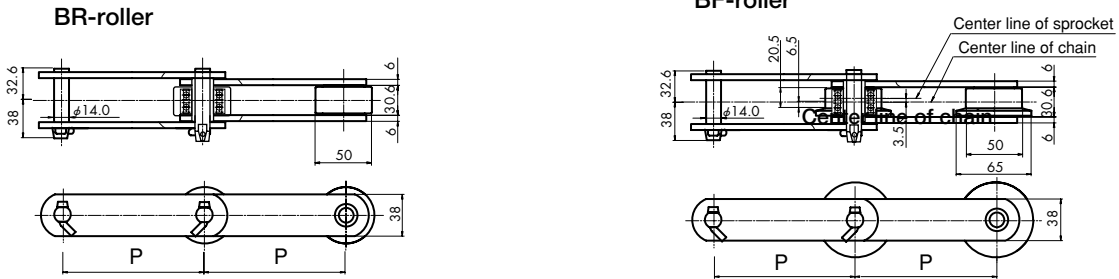

Chain No.		Avg. tensile strength kN (kgf)		Pitch	Standard attachments													
Chain size	Roller type	Normal A,J	Heavy duty K,E	P	A1 · K1		A2 · K2		A3 · K3		SA2 · SK2		GA2 · GK2	G4				
					N	N	N	K	N	K	N	K	K	K	Y	B		
DK 11100	BR,BF	112 (11,500)	225 (23,000)	100	—	70	40	—	—	—	70	40	35	—	—	—		
DK 11125	BR,BF			125	—	80	50	—	—	—	—	—	35	—	—	—	—	
DK 11150	BR,BF			150	—	90	60	—	—	—	—	90	60	60	—	—	—	—
DK 11200	BR,BF			200	—	110	80	—	—	—	—	—	—	80	—	—	—	—

Chain No.		Combination of standard attachments and rollers						Approx. weight kg/m		Attachment weight (kg)					Roller allowable load (kgf/pc)	
Chain size	Roller type	A1 K1	A2 K2	A3 K3	SA2 SK2	GA2 GK2	G4	BR-roller	BF-roller	A2 SA2	A3	K2 SK2	K3	G4	BR	BF
DK 11100	BR,BF	—	BR,BF	—	BR	—	—	9.6	10.1	0.19	—	0.39	—	—	315	235
DK 11125	BR,BF	—	BR,BF	—	—	BR,BF	—	8.5	8.9	0.21	—	0.42	—	—		
DK 11150	BR,BF	—	BR,BF	—	BR	BR,BF	—	7.6	7.9	0.24	—	0.48	—	—		
DK 11200	BR,BF	—	BR,BF	—	—	BR,BF	—	6.5	6.8	0.29	—	0.58	—	—		

Note: 1. The dimensions of the normal and heavy duty chains are the same, but heavy duty chains are made of high-strength and structural steel, and are suitable when higher safety rate, strength or wear resistance is required.  
 2. With Attachment GA2 and GK2, check the bolt length limits shown above.  
 3. Roller allowable load depends on the tension resistance of the rail. The values in the table were calculated with a rail made of a material with 400kN/mm<sup>2</sup>.

# Dimensional Drawings: DK 13150 and DK 13200 (for Metric series)

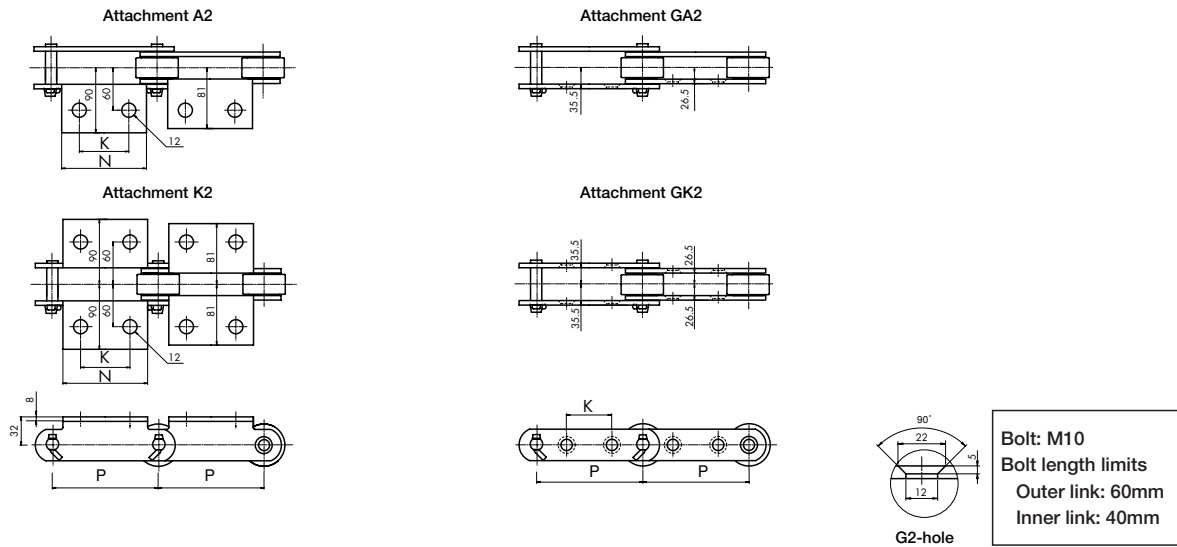
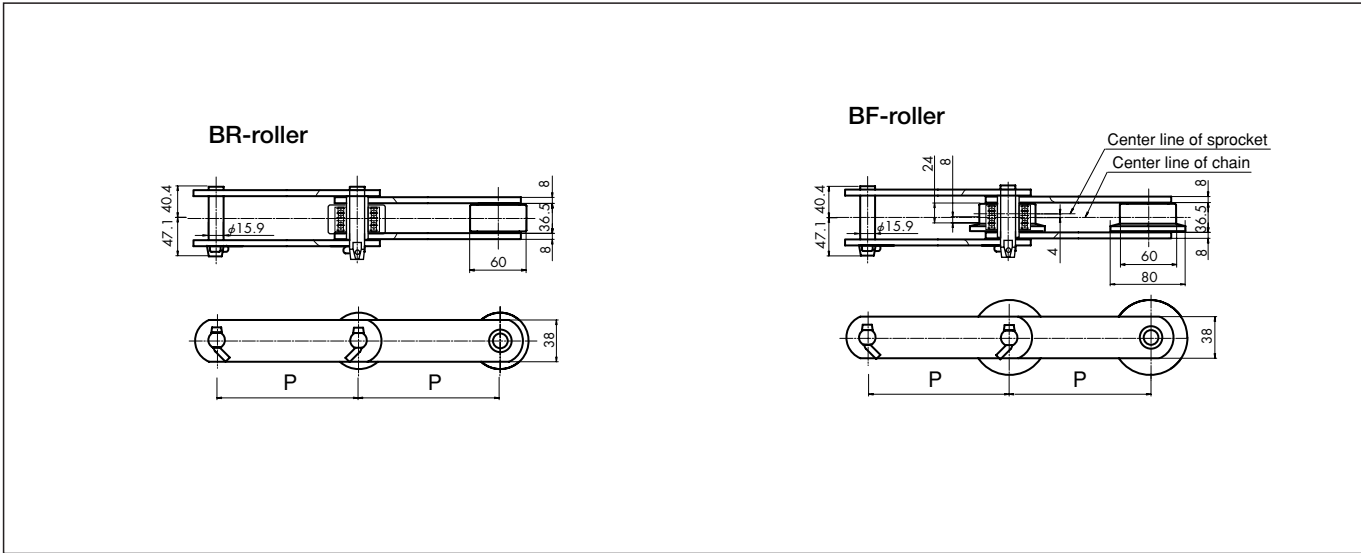

Chain No.		Avg. tensile strength kN (kgf)		Pitch	Standard attachments										
Chain size	Roller type	Normal <b>A,J</b>	Heavy duty <b>K,E</b>	P	A2 · K2		A3 · K3		SA2 · SK2		GA2 · GK2	G4			
					K	N	K	N	K	K	K	Y	B		
<b>DK 13150</b>	<b>BR,BF</b>	127	240	150	—	90	60	—	—	—	—	45	—	—	—
<b>DK 13200</b>	<b>BR,BF</b>	(13,000)	(24,500)	200	—	110	80	—	—	—	—	80	—	—	—

Chain No.		Combination of standard attachments and rollers						Approx. weight kg/m		Attachment weight (kg)					Roller allowable load (kgf/pc)	
Chain size	Roller type	A1 K1	A2 K2	A3 K3	SA2 SK2	GA2 GK2	G4	BR-roller	BF-roller	A2 SA2	A3	K2 SK2	K3	G4	BR	BF
		<b>DK 13150</b>	<b>BR,BF</b>	—	BR,BF	—	—	BR,BF	—	10.9	11.6	0.39	—	0.78	—	—
<b>DK 13200</b>	<b>BR,BF</b>	—	BR,BF	—	—	BR,BF	—	9.3	9.8	0.48	—	0.96	—	—	—	—

Note: 1. The dimensions of the normal and heavy duty chains are the same, but heavy duty chains are made of high-strength and structural steel, and are suitable when higher safety rate, strength or wear resistance is required.  
 2. With Attachment GA2 and GK2, check the bolt length limits shown above.  
 3. Roller allowable load depends on the tension resistance of the rail. The values in the table were calculated with a rail made of a material with 400kN/mm<sup>2</sup>.

DK Conveyor Chains  
Bearing Assembled Roller Type Conveyor Chain

## Dimensional Drawings: DK 19200, DK 19250 and DK 19300 (for Metric series)

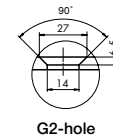
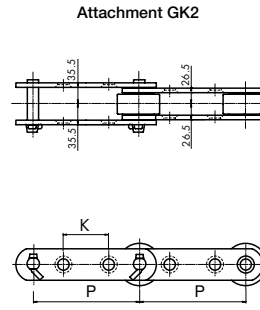
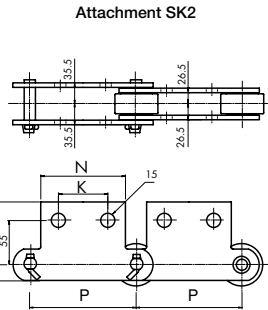
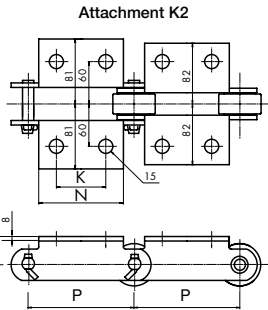
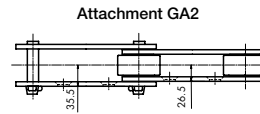
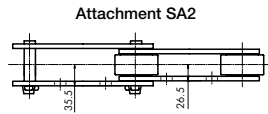
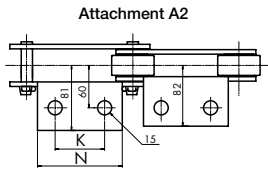
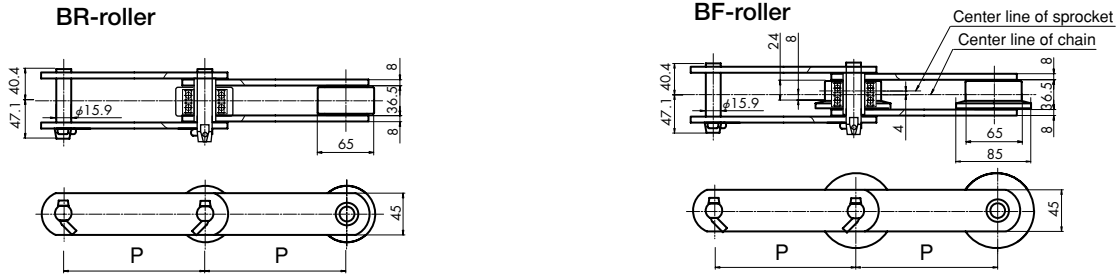

**Bolt: M12**  
**Bolt length limits**  
 Outer link: 63mm  
 Inner link: 45mm

Chain No.		Avg. tensile strength kN (kgf)		Pitch	Standard attachments										
Chain size	Roller type	Normal A,J	Heavy duty K,E	P	A1 · K1		A2 · K2		A3 · K3		SA2 · SK2		GA2 · GK2	G4	
					N	K	N	K	N	K	N	K	K	Y	B
<b>DK 19200</b>	<b>BR,BF</b>	186 (19,000)	279 (28,500)	200	—	120	80	—	—	120	80	80	—	—	—
<b>DK 19250</b>	<b>BR,BF</b>			250	—	170	125	—	—	170	125	125	—	—	—
<b>DK 19300</b>	<b>BR,BF</b>			300	—	220	180	—	—	—	—	150	—	—	—

Chain No.		Combination of standard attachments and rollers						Approx. weight kg/m		Attachment weight (kg)					Roller allowable load (kg/pc)	
Chain size	Roller type	A1 K1	A2 K2	A3 K3	SA2 SK2	GA2 GK2	G4	BR-roller	BF-roller	A2 SA2	A3	K2 SK2	K3	G4	BR	BF
		<b>DK 19200</b>	<b>BR,BF</b>	—	BR,BF	—	BR	BR,BF	—	11.5	12.1	0.49	—	0.98	—	—
<b>DK 19250</b>	<b>BR,BF</b>	—	BR,BF	—	BR	BR,BF	—	10.3	10.8	0.69	—	1.38	—			
<b>DK 19300</b>	<b>BR,BF</b>	—	BR,BF	—	—	BR,BF	—	9.5	10.0	0.89	—	1.78	—			

Note: 1. The dimensions of the normal and heavy duty chains are the same, but heavy duty chains are made of high-strength and structural steel, and are suitable when higher safety rate, strength or wear resistance is required.  
 2. With Attachment GA2 and GK2, check the bolt length limits shown above.  
 3. Roller allowable load depends on the tension resistance of the rail. The values in the table were calculated with a rail made of a material with 400kN/mm<sup>2</sup>.

## Dimensional Drawings: DK 25200, DK 25250 and DK 25300 (for Metric series)

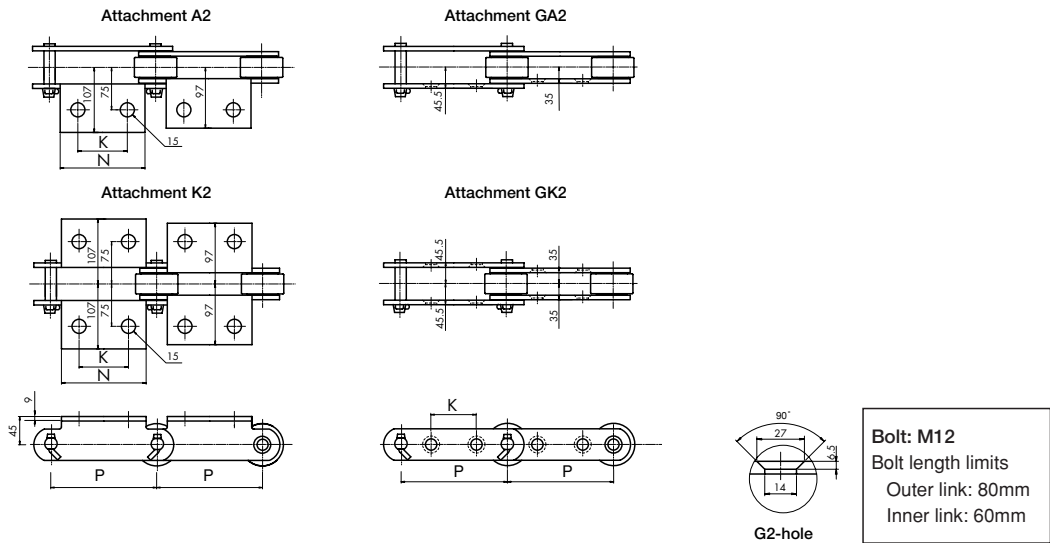
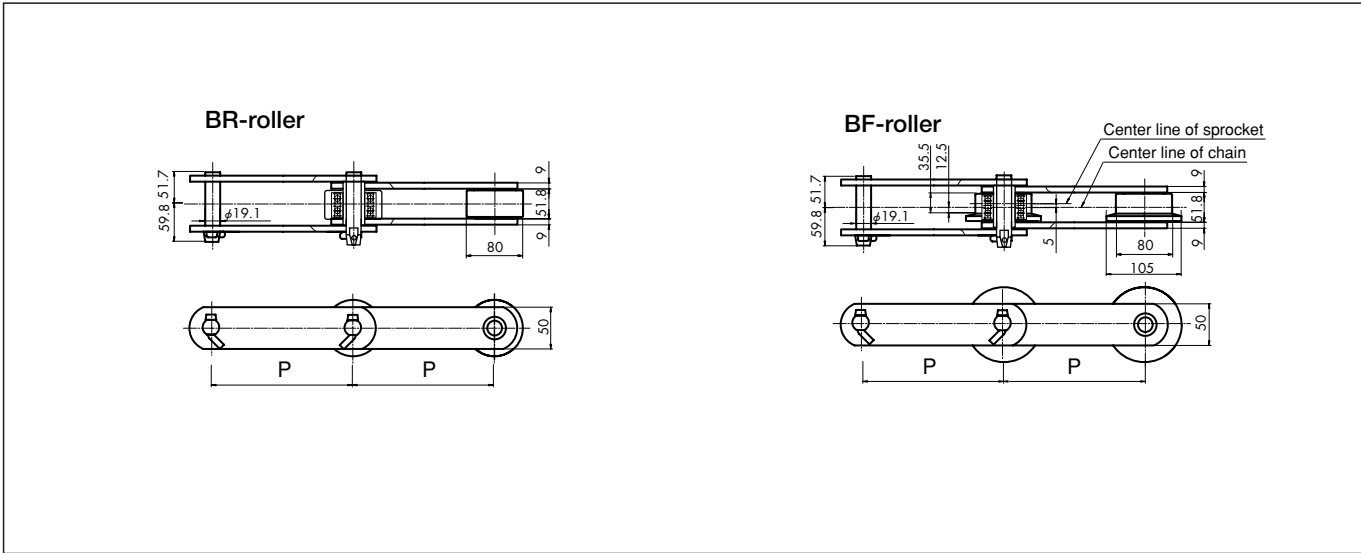

Chain No.		Avg. tensile strength kN (kgf)		Pitch	Standard attachments											
Chain size	Roller type	Normal <b>A,J</b>	Heavy duty <b>K,E</b>	P	A1 · K1		A2 · K2		A3 · K3		SA2 · SK2		GA2 · GK2		G4	
					N	K	N	K	N	K	N	K	K	Y	B	
<b>DK 25200</b>	<b>BR,BF</b>	245 (25,000)	392 (40,000)	200	—	120	80	—	—	—	—	70	—	—	—	
<b>DK 25250</b>	<b>BR,BF</b>			250	—	170	125	—	—	—	—	110	—	—	—	
<b>DK 25300</b>	<b>BR,BF</b>			300	—	220	180	—	—	—	—	150	—	—	—	

Chain No.		Combination of standard attachments and rollers						Approx. weight kg/m		Attachment weight (kg)					Roller allowable load (kg/pc)	
Chain size	Roller type	A1	A2	A3	SA2	GA2	G4	BR-roller	BF-roller	A2	A3	K2	K3	G4	BR	BF
		K1	K2	K3	SK2	GK2	—	SA2	SK2	—	—	—	—			
<b>DK 25200</b>	<b>BR,BF</b>	—	BR,BF	—	—	BR,BF	—	18.2	19.5	0.63	—	1.26	—	—	845	635
<b>DK 25250</b>	<b>BR,BF</b>	—	BR,BF	—	—	BR,BF	—	15.9	17.0	0.90	—	1.80	—	—		
<b>DK 25300</b>	<b>BR,BF</b>	—	BR,BF	—	—	BR,BF	—	14.5	15.3	1.16	—	2.32	—	—		

- Note: 1. The dimensions of the normal and heavy duty chains are the same, but heavy duty chains are made of high-strength and structural steel, and are suitable when higher safety rate, strength or wear resistance is required.  
 2. With Attachment GA2 and GK2, check the bolt length limits shown above.  
 3. Roller allowable load depends on the tension resistance of the rail. The values in the table were calculated with a rail made of a material with 400kN/mm<sup>2</sup>.

DK Conveyor Chains  
Bearing Assembled Roller Type Conveyor Chain



## Dimensional Drawings: DK 32200, DK 32250, DK 32300, and DK 32450 (for Metric series)

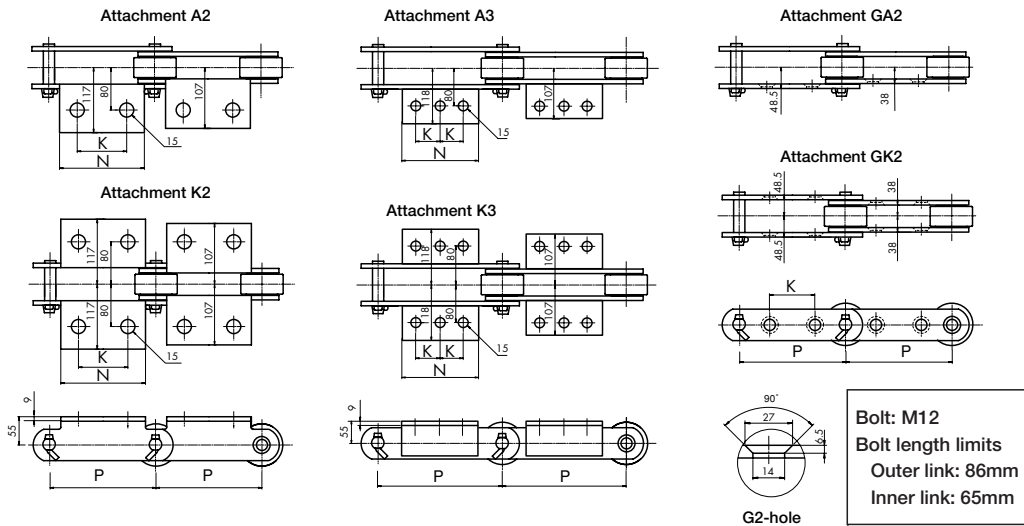
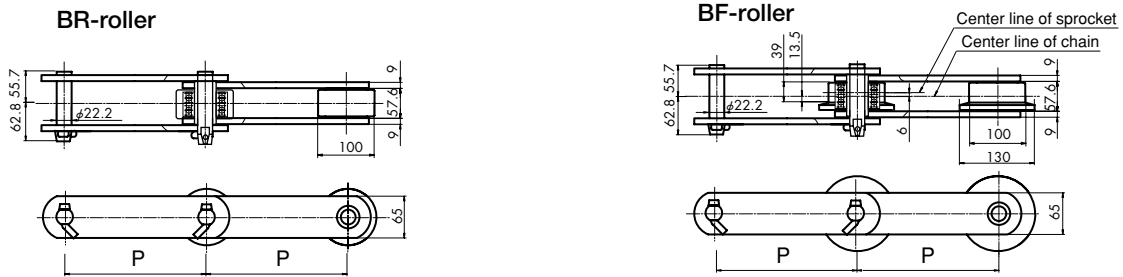

Chain No.		Avg. tensile strength kN (kgf)		Pitch P	Standard attachments									
Chain size	Roller type	Normal A,J	Heavy duty K,E		A1 · K1 N	A2 · K2 N	A3 · K3 N	SA2 · SK2 N	GA2 · GK2 K	G4				
DK 32200	BR,BF	313 (32,000)	500 (51,000)	200	120	—	—	—	—	70(40)	—	—	—	
DK 32250	BR,BF			250	170	—	—	—	—	110(90)	—	—	—	
DK 32300	BR,BF			300	220	—	—	—	—	140	—	—	—	
DK 32450	BR,BF			450	—	330	140	—	—	220	—	—	—	

Chain No.		Combination of standard attachments and rollers						Approx. weight kg/m		Attachment weight (kg)					Roller allowable load (kgf/pc)	
Chain size	Roller type	A1 K1	A2 K2	A3 K3	SA2 SK2	GA2 GK2	G4	BR-roller	BF-roller	A2 SA2	A3	K2 SK2	K3	G4	BR	BF
DK 32200	BR,BF	—	BR,BF	—	—	BR,BF	—	28.2	30.2	0.72	—	1.44	—	—	1,240	930
DK 32250	BR,BF	—	BR,BF	—	—	BR,BF	—	24.6	26.2	1.01	—	2.02	—			
DK 32300	BR,BF	—	BR,BF	—	—	BR,BF	—	22.0	23.4	1.31	—	2.62	—			
DK 32450	BR,BF	—	—	BR,BF	—	BR,BF	—	17.8	18.7	—	1.97	—	3.97			

- Note: 1. The dimensions of the normal and heavy duty chains are the same, but heavy duty chains are made of high-strength and structural steel, and are suitable when higher safety rate, strength or wear resistance is required.  
 2. K values in ( ) for Attachment GA2 and GK2 are for Roller BF.  
 3. With Attachment GA2 and GK2, check the bolt length limits shown above.  
 4. Attachment A3 and K3 are angle welding attachments.  
 5. Roller allowable load depends on the tension resistance of the rail. The values in the table were calculated with a rail made of a material with 400kN/mm<sup>2</sup>.

## Dimensional Drawings: DK 50250, DK 50300, DK 50450, and DK 50600 (for Metric series)

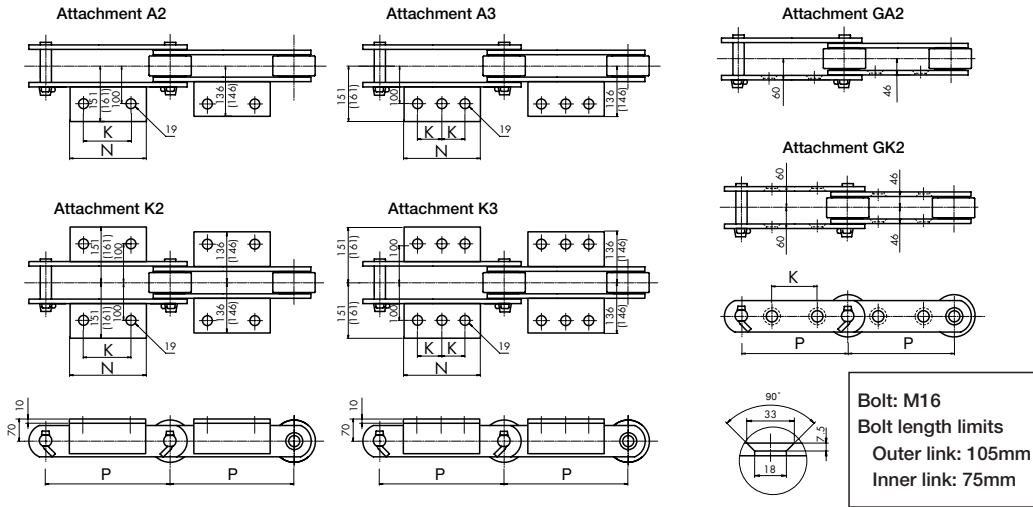
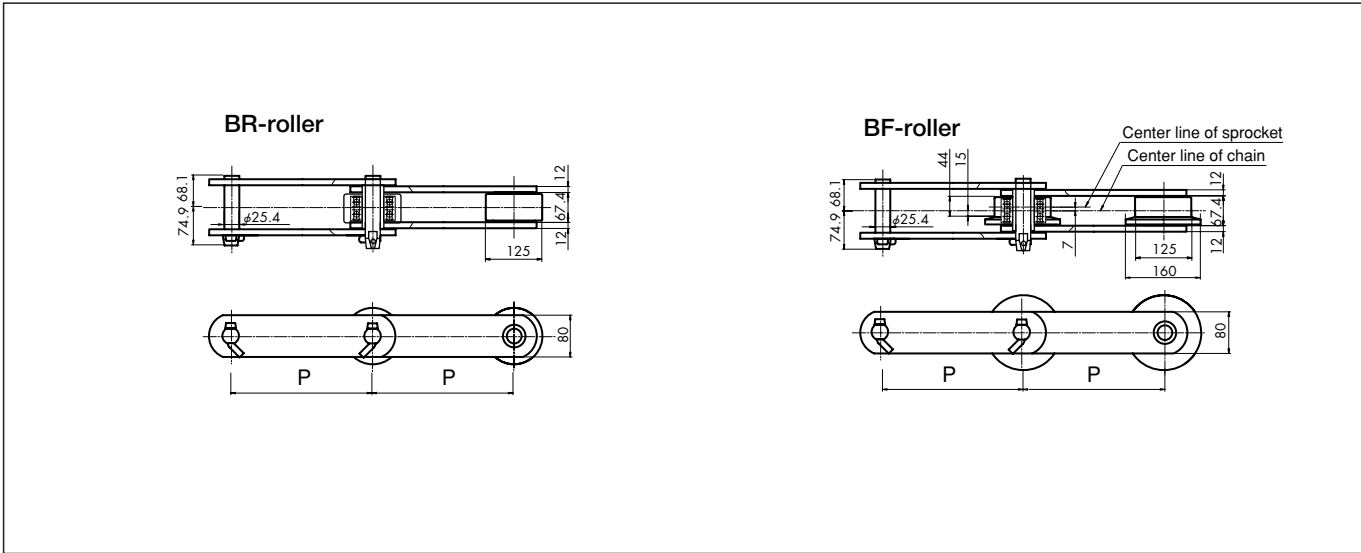

※The values of Attachment A3 and K3 in ( ) are for stainless steel types.

Chain No.		Avg. tensile strength kN (kgf)		Pitch P	Standard attachments											
Chain size	Roller type	Normal A,J	Heavy duty K,E		A2 · K2		A3 · K3		SA2 · SK2		GA2 · GK2		G4			
				K	N	K	N	K	N	K	K	K	Y	B		
DK 50250	BR,BF	490 (50,000)	686 (70,000)	250	—	170	125	—	—	—	—	90 (55)	—	—		
DK 50300	BR,BF			300	—	220	180	—	—	—	—	140(105)	—	—	—	
DK 50450	BR,BF			450	—	—	—	330	140	—	—	—	—	—	—	—
DK 50600	BR,BF			600	—	—	—	410	180	—	—	—	300	—	—	—

Chain No.		Combination of standard attachments and rollers						Approx. weight kg/m		Attachment weight (kg)					Roller allowable load (kgf/pc)	
Chain size	Roller type	A1 K1	A2 K2	A3 K3	SA2 SK2	GA2 GK2	G4	BR-roller	BF-roller	A2 SA2	A3	K2 SK2	K3	G4	BR	BF
DK 50250	BR,BF	—	BR,BF	—	—	BR,BF	—	42.7	45.8	2.26	—	4.52	—	—	1,695	1,265
DK 50300	BR,BF	—	BR,BF	—	—	BR,BF	—	38.0	40.4	2.93	—	5.86	—	—		
DK 50450	BR,BF	—	—	BR,BF	—	BR,BF	—	30.3	31.9	—	4.39	—	8.78	—		
DK 50600	BR,BF	—	—	BR,BF	—	BR,BF	—	26.7	28.0	—	5.45	—	10.90	—		

- Note: 1. The dimensions of the normal and heavy duty chains are the same, but heavy duty chains are made of high-strength and structural steel, and are suitable when higher safety rate, strength or wear resistance is required.  
 2. K values in ( ) for Attachment GA2 and GK2 are for Roller BF.  
 3. With Attachment GA2 and GK2, check the bolt length limits shown above.  
 4. Attachment A3 and K3 are angle welding attachments.  
 5. Roller allowable load depends on the tension resistance of the rail. The values in the table were calculated with a rail made of a material with 400kN/mm<sup>2</sup>.

DK Conveyor Chains  
Bearing Assembled Roller Type Conveyor Chain

## Dimensional Drawings: DK 11152 (for Inch series)

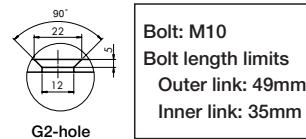
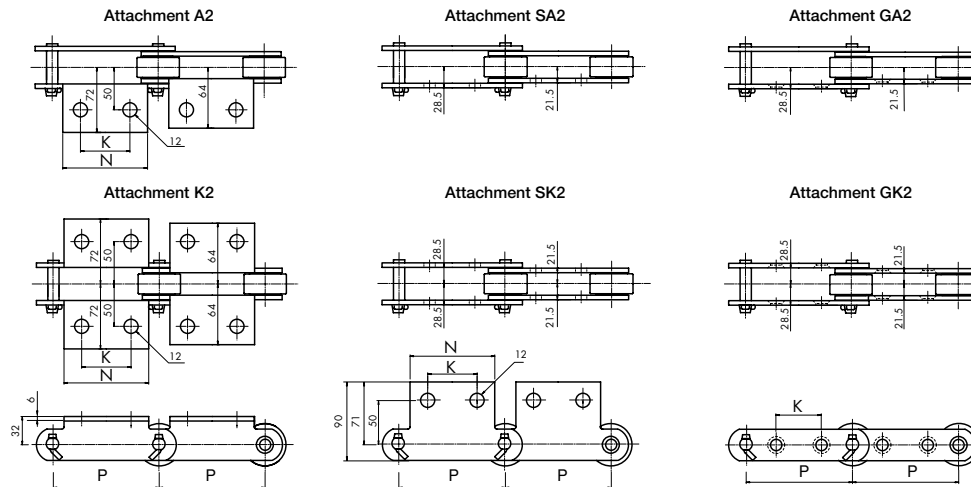
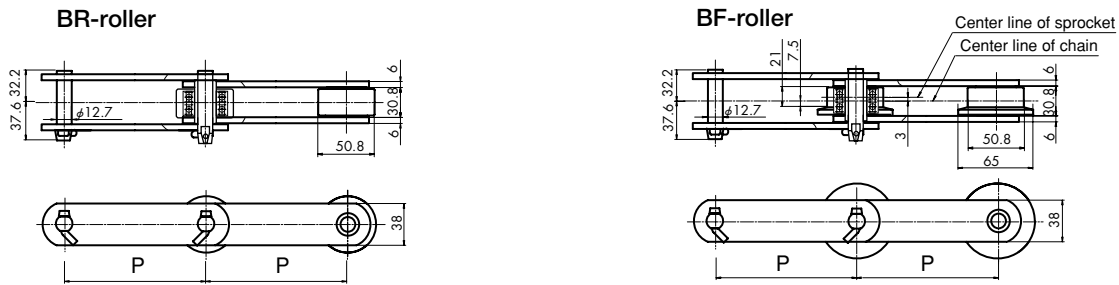

Chain No.		Avg. tensile strength kN (kgf)		Pitch	Standard attachments										
Chain size	Roller type	Normal <b>A,J</b>	Heavy duty <b>K,E</b>	P	A2 · K2		A3 · K3		SA2 · SK2		GA2 · GK2		G4		
					K	N	K	N	K	N	K	K	K	Y	B
<b>DK 11152</b>	<b>BR,BF</b>	112 (11,500)	171 (17,500)	152.4	—	90	60	—	—	—	—	60	—	—	—

Chain No.		Combination of standard attachments and rollers						Approx. weight kg/m		Attachment weight (kg)					Roller allowable load (kgf/pc)	
Chain size	Roller type	A1	A2	A3	SA2	GA2	G4	BR-roller	BF-roller	A2	A3	K2	K3	G4	BR	BF
		K1	K2	K3	SK2	GK2				SA2		SK2				
<b>DK 11152</b>	<b>BR,BF</b>	—	BR,BF	—	BR	BR,BF	—	7.4	7.9	0.22	—	0.44	—	—	335	245

Note: 1. The dimensions of the normal and heavy duty chains are the same, but heavy duty chains are made of high-strength and structural steel, and are suitable when higher safety rate, strength or wear resistance is required.  
 2. With Attachment GA2 and GK2, check the bolt length limits shown above.  
 3. Roller allowable load depends on the tension resistance of the rail. The values in the table were calculated with a rail made of a material with 400kN/mm<sup>2</sup>.

# Dimensional Drawings: DK 19152 (for Inch series)

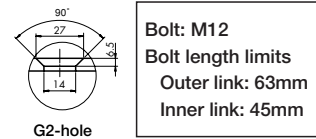
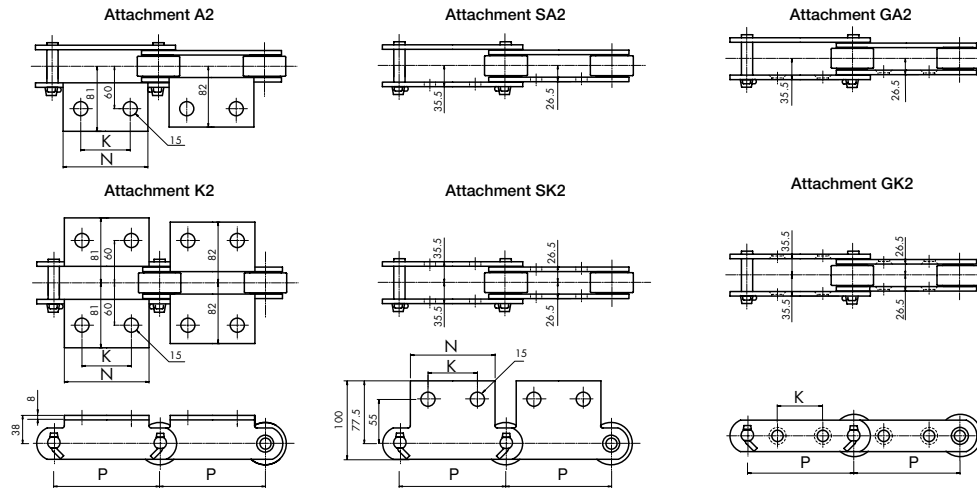
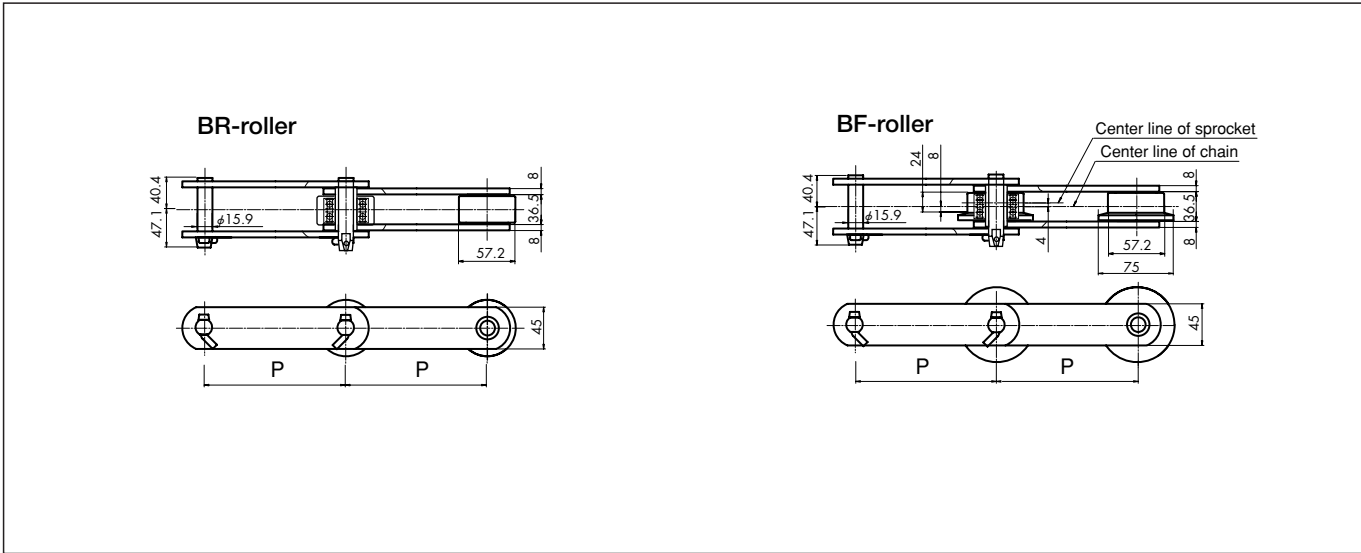

Chain No.		Avg. tensile strength kN (kgf)		Pitch	Standard attachments										
Chain size	Roller type	Normal <b>A,J</b>	Heavy duty <b>K,E</b>	P	A2 · K2		A3 · K3		SA2 · SK2		GA2 · GK2		G4		
					K	N	K	N	K	N	K	K	K	Y	B
<b>DK 19152</b>	<b>BR,BF</b>	186 (19,000)	279 (28,500)	152.4	—	100	60	—	—	100	60	50	—	—	—

Chain No.		Combination of standard attachments and rollers						Approx. weight kg/m		Attachment weight (kg)					Roller allowable load (kgf/pc)	
Chain size	Roller type	A1 K1	A2 K2	A3 K3	SA2 SK2	GA2 GK2	G4	BR-roller	BF-roller	A2 SA2	A3	K2 SK2	K3	G4	BR	BF
		<b>DK 19152</b>	<b>BR,BF</b>	—	BR,BF	—	BR	BR,BF	—	11.8	12.2	0.41	—	0.82	—	—

Note: 1. The dimensions of the normal and heavy duty chains are the same, but heavy duty chains are made of high-strength and structural steel, and are suitable when higher safety rate, strength or wear resistance is required.  
 2. With Attachment GA2 and GK2, check the bolt length limits shown above.  
 3. Roller allowable load depends on the tension resistance of the rail. The values in the table were calculated with a rail made of a material with 400kN/mm<sup>2</sup>.

DK Conveyor Chains  
 Bearing Assembled Roller Type Conveyor Chain

## Dimensional Drawings: DK 25152 (for Inch series)

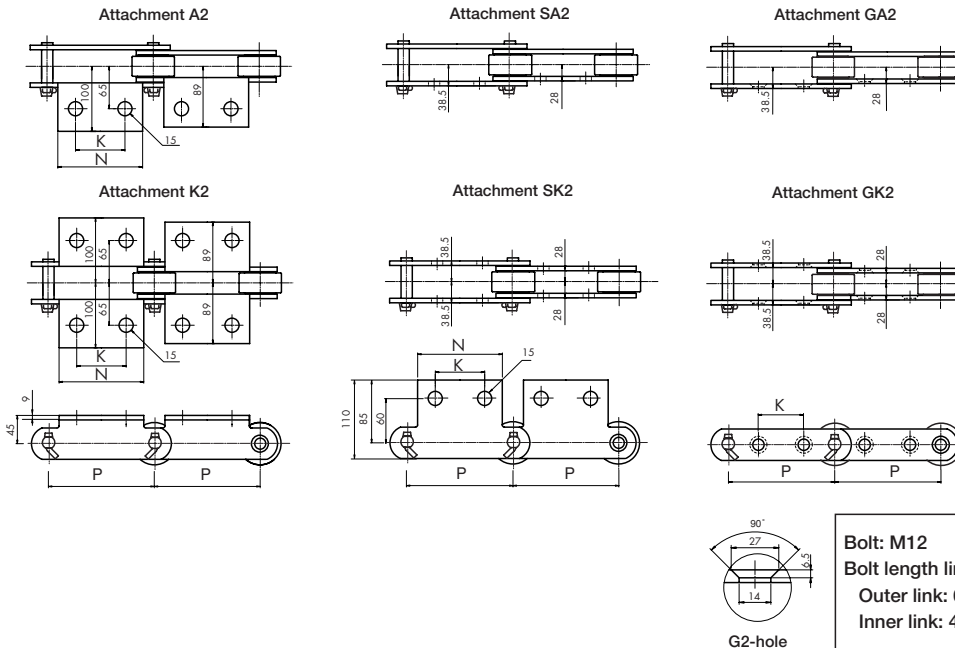
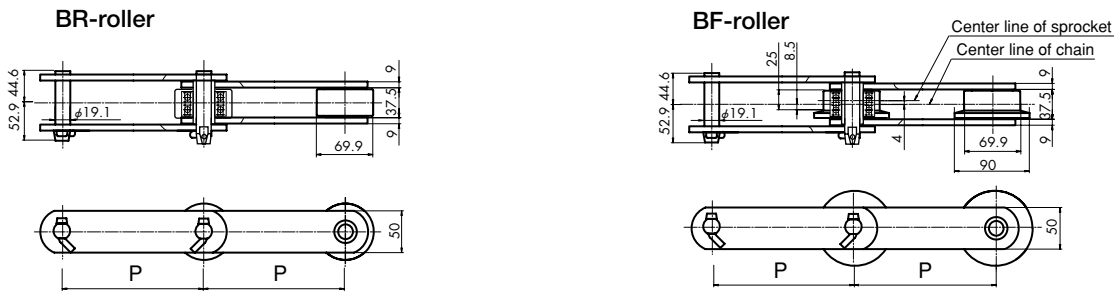

Chain No.		Avg. tensile strength kN (kgf)		Pitch	Standard attachments										
Chain size	Roller type	Normal A,J	Heavy duty K,E	P	A2 · K2		A3 · K3		SA2 · SK2		GA2 · GK2	G4			
					K	N	K	N	K	N	K	K	K	Y	B
<b>DK 25152</b>	<b>BR,BF</b>	245 (25,000)	392 (40,000)	152.4	—	100	60	—	—	100	60	55(35)	—	—	—

Chain No.		Combination of standard attachments and rollers						Approx. weight kg/m		Attachment weight (kg)					Roller allowable load (kg/pc)	
Chain size	Roller type	A1 K1	A2 K2	A3 K3	SA2 SK2	GA2 GK2	G4	BR-roller	BF-roller	A2 SA2	A3	K2 SK2	K3	G4	BR	BF
		<b>DK 25152</b>	<b>BR,BF</b>	—	BR,BF	—	BR	BR,BF	—	11.8	12.2	0.53	—	1.06	—	—

Note: 1. The dimensions of the normal and heavy duty chains are the same, but heavy duty chains are made of high-strength and structural steel, and are suitable when higher safety rate, strength or wear resistance is required.  
 2. K values in ( ) Attachment GA2 and GK2 are for Roller BF.  
 3. With Attachment GA2 and GK2, check the bolt length limits shown above.  
 4. Roller allowable load depends on the tension resistance of the rail. The values in the table were calculated with a rail made of a material with 400kN/mm<sup>2</sup>.

## Seal Chain

By placing a seal ring between the inner and outer plates, this conveyor chain has grease enclosed between the pins and bushings. Chain endurance is significantly improved with this design as friction between the pins and the bushings is substantially lowered.



- Heat resistance of seal rings is approx. 80°C.
- Sprockets for Standard Conveyor Chains can be used.
- Various attachments are available upon request.

## Application examples

- Equipment with tendency to elongate chains.
- Equipment used in severe circumstances.
- Maintenance-free is needed.
- Conveyor lines, construction machinery.

## Comparison of Wear Resistance (no lubrication during testing)

- Comparison of Wear Resistance (no lubrication during testing)

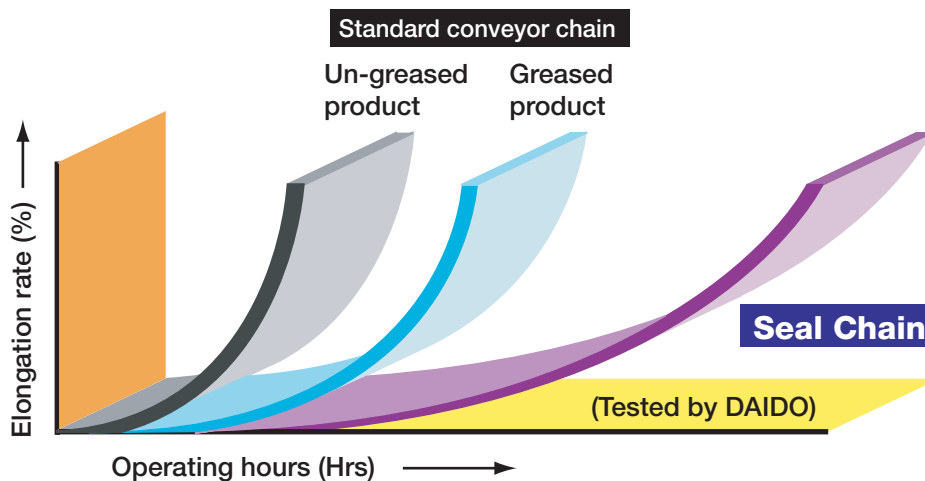

- By lubricating the Seal Chain from time to time, chain life can be further lengthened and the effects of rust resistance can be expected as well. Applicable lubrication oil: SAE30 to SAE40  
Do not use gasoline, phosphate ester hydraulic fluids, and chemicals such as benzol, trichlene, and acetone, as they may damage the seal rings.

## Dimensional Drawings: Seal Chains

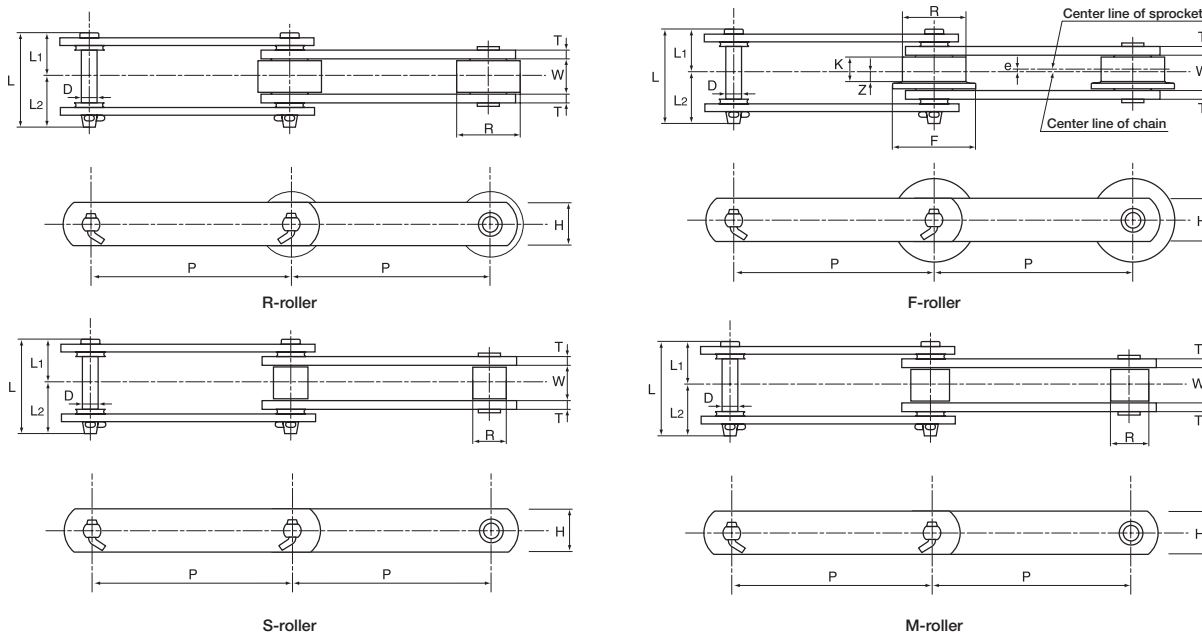

Chain No.		Avg. tensile strength kN (kgf)		Pitch	Width	R-roller	F-roller				S-roller M-roller		Pin				Plate		Approx. weight kg/m				
Chain size	Roller type	Normal A,J	Heavy duty K,E	P	W	R	R	F	K	e	Z	R	R	D	L	L1	L2	T	H	R-roller	F-roller	S-roller	M-roller
<b>DK 19200V</b>	<b>R,F,S,M</b>			200																11.6	12.2	8.5	8.7
<b>DK 19250V</b>	<b>R,F,S,M</b>	186 (19,000)	250 (25,500)	250	36.5	65	65	85	24	4	8	34.9	38.1	15.9	94.3	43.8	50.5	8	45	10.4	10.9	8.0	8.2
<b>DK 19300V</b>	<b>R,F,S,M</b>			300																9.6	10.1	7.6	7.9
<b>DK 25200V</b>	<b>R,F,S,M</b>			200																18.3	19.6	11.5	12.0
<b>DK 25250V</b>	<b>R,F,S,M</b>	245 (25,000)	353 (36,000)	250	51.8	80	80	105	35.5	5	12.5	40.1	44.5	19.1	117.9	54.9	63.0	9	50	16.0	17.1	10.7	11.1
<b>DK 25300V</b>	<b>R,F,S,M</b>			300																14.6	15.4	10.0	10.4
<b>DK 19152V</b>	<b>R,F,S,M</b>	186 (19,000)	250 (25,500)	152.4	36.5	57.2	57.2	75	24	4	8	34.9	38.1	15.9	94.3	43.8	50.5	8	45	11.9	12.3	9.2	9.5
<b>DK 25152V</b>	<b>R,F,S,M</b>	245 (25,000)	353 (36,000)	152.4	37.5	69.9	69.9	90	25	4	8.5	40.1	44.5	19.1	103.9	47.8	56.1	9	50	16.5	17.4	12.1	12.7

- Note: 1. The avg. tensile strength of a heavy duty chain is about 90% of that of the Standard Multipurpose Conveyor Chain.  
 2. Sprockets for Standard Conveyor Chain can be used.  
 3. The heat resistance of the seal rings is about 80°C.  
 4. Consult us for sizes not mentioned above, heat resistance higher than 80°C, or other options like adding grease holes to pins.  
 5. Ask us for delivery time.



## Strong H-type and Z-type Conveyor Chain

This chain was developed for heavy load conveyance such as for large bucket elevators and flow conveyors. Larger bearing areas are taken for the pins, bushings, and rollers compared to those of Standard Conveyor Chains to improve wear resistance. In addition, the chain is manufactured with high precision to have high tensile strength, fatigue strength, and superb shock resistance. It is a premium large conveyor chain that can be used for a long duration.

- Strong H-type is best for flow conveyor systems as the inner and outer plates have the same height.
- Strong Z-type is best for vertical conveyor systems as the inner and outer plates with elevated height exhibit greater strength.
- Consult us for attachments other than standard G4.



## Application examples

- Large flow conveyor systems
- Basket elevators
- Multilevel parking machines

## Table of applicable attachments

Chain nominal No.	Attachments for specific use		
	Flow conveyor		
	L	KL	B
DK 35H200	○	○	○
DK 35H250	○	○	○
DK 50H200	◎	◎	◎
DK 50H225	○	○	○
DK 50H250	○	○	○
DK 50H300	○	○	○
DK 75H200	◎	◎	◎
DK 75H250	◎	◎	◎
DK 75H300	◎	◎	◎
DK 75H350	○	○	○
DK 100H250	◎	◎	◎
DK 100H300	◎	◎	◎
DK 100H350	◎	◎	◎
DK 120H250	○	○	○
DK 120H300	◎	◎	◎
DK 120H350	◎	◎	◎
DK 120H400	○	○	○
DK 140H300	○	○	○
DK 140H350	◎	◎	◎
DK 140H400	○	○	○
DK 160H300	○	○	○
DK 160H350	◎	◎	◎
DK 160H400	○	○	○
DK 200H350	○	○	○
DK 200H400	○	○	○
DK 200H450	○	○	○
DK 250H350	○	○	○
DK 250H400	○	○	○
DK 250H500	○	○	○

Chain nominal No.	Standard attachment
	G4
DK 35Z200	◎
DK 35Z250	◎
DK 50Z200	◎
DK 50Z225	◎
DK 50Z250	◎
DK 50Z300	◎
DK 75Z200	◎
DK 75Z250	◎
DK 75Z300	◎
DK 75Z350	◎
DK 100Z250	◎
DK 100Z300	◎
DK 100Z350	◎
DK 120Z250	◎
DK 120Z300	◎
DK 120Z350	◎
DK 120Z400	◎
DK 140Z300	◎
DK 140Z350	◎
DK 140Z400	◎
DK 160Z300	◎
DK 160Z350	◎
DK 160Z400	◎
DK 200Z350	◎
DK 200Z400	◎
DK 200Z450	◎
DK 250Z350	◎
DK 250Z400	◎
DK 250Z500	◎

◎ : Standard product      ○ : Nonstandard product

Note: Consult us for manufacturing nonstandard products or attachments not included in the above table.

**Dimensional Drawings: Strong H-type Conveyor Chain**

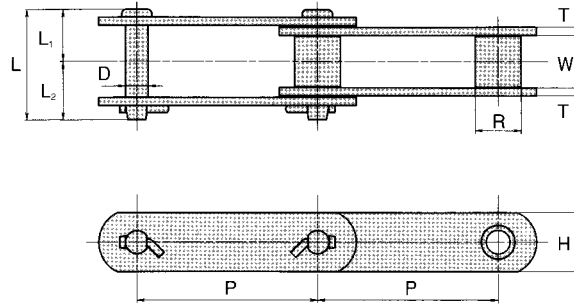

Strong H-type

Chain No.	Avg. tensile strength kN (kgf)	Pitch	Roller link width	Roller M	Pin				Plate		Approx. weight (kg/m)
		P	W	R	D	L	L1	L2	T	H	
<b>DK 35H200M</b>	323 (33,000)	200	51.8	44.5	22.2	114	53.8	60.2	9	50	12.2
<b>DK 35H250M</b>		250									11.2
<b>DK 50H200M</b>	490 (50,000)	200	57.6	50.8	25.4	121.5	57.3	64.2	9	65	17.0
<b>DK 50H225M</b>		225									16.2
<b>DK 50H250M</b>		250									15.5
<b>DK 50H300M</b>		300									14.5
<b>DK 75H200M</b>	735 (75,000)	200	67.4	63.5	31.75	148	70	78	12	80	30.0
<b>DK 75H250M</b>		250									27.0
<b>DK 75H300M</b>		300									25.0
<b>DK 75H350M</b>		350									23.7
<b>DK 100H250M</b>	980 (100,000)	250	75	70	35	174	83.2	90.8	16	90	41.2
<b>DK 100H300M</b>		300									38.2
<b>DK 100H350M</b>		350									35.9
<b>DK 120H250M</b>	1,176 (120,000)	250	82.5	75	38.5	183.5	88	95.5	16	100	48.6
<b>DK 120H300M</b>		300									44.8
<b>DK 120H350M</b>		350									41.8
<b>DK 120H400M</b>		400									39.9
<b>DK 140H300M</b>	1,372 (140,000)	300	85	82	41.75	189.5	90.2	99.3	16	115	54.2
<b>DK 140H350M</b>		350									50.5
<b>DK 140H400M</b>		400									47.8
<b>DK 160H300M</b>	1,569 (160,000)	300	92.5	86	44.5	211.5	101.2	110.3	19	120	66.9
<b>DK 160H350M</b>		350									62.8
<b>DK 160H400M</b>		400									58.9
<b>DK 200H350M</b>	1,961 (200,000)	350	95	97	50.8	217.5	103.5	114	19	140	76.1
<b>DK 200H400M</b>		400									71.9
<b>DK 200H450M</b>		450									68.3
<b>DK 250H350M</b>	2,451 (250,000)	350	100	107	56	236	113	123	22	150	99.0
<b>DK 250H400M</b>		400									90.0
<b>DK 250H500M</b>		450									77.4

Note: 1. See the section of Chain for Continuous Flow Conveyor in the DK Specialty Conveyor Chain for the dimensions of the attachments for the flow conveyor.  
 2. Consult us for manufacturing other attachments and roller types.

DK Conveyor Chains  
Strong H-type and Z-type Conveyor Chain

## Dimensional Drawings: Strong Z-type Conveyor Chain with attachment

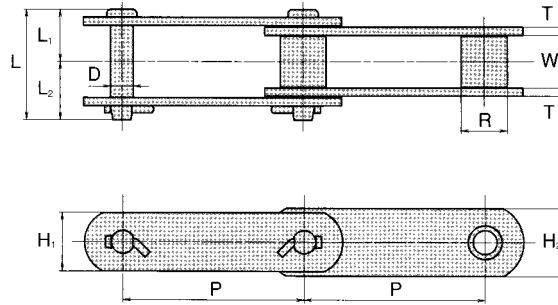

Strong Z-type

Chain No.	Avg. tensile strength kN (kgf)	Pitch	Roller link width		Roller M	Pin				Plate			Approx. weight (kg/m)
		P	W	R	D	L	L1	L2	T	H1	H2		
<b>DK 35Z200M</b>	392 (40,000)	200	51.8	44.5	22.2	114	53.8	60.2	9	50	57	12.7	
<b>DK 35Z250M</b>		250										11.7	
<b>DK 50Z200M</b>	588 (60,000)	200	57.6	50.8	25.4	121.5	57.3	64.2	9	65	75	17.7	
<b>DK 50Z225M</b>		225										16.9	
<b>DK 50Z250M</b>		250										16.2	
<b>DK 50Z300M</b>		300										15.2	
<b>DK 75Z200M</b>	931 (95,000)	200	67.4	63.5	31.75	148	70	78	12	80	90	31.2	
<b>DK 75Z250M</b>		250										28.0	
<b>DK 75Z300M</b>		300										26.0	
<b>DK 75Z350M</b>		350										24.6	
<b>DK 100Z250M</b>	1,225 (125,000)	250	75	70	35	174	83.2	90.8	16	90	100	42.5	
<b>DK 100Z300M</b>		300										39.5	
<b>DK 100Z350M</b>		350										37.2	
<b>DK 120Z250M</b>	1,470 (150,000)	250	82.5	75	38.5	183.5	88	95.5	16	100	115	50.6	
<b>DK 120Z300M</b>		300										46.8	
<b>DK 120Z350M</b>		350										43.7	
<b>DK 120Z400M</b>		400										41.6	
<b>DK 140Z300M</b>	1,667 (170,000)	300	85	82	41.75	189.5	90.2	99.3	16	115	125	55.5	
<b>DK 140Z350M</b>		350										51.8	
<b>DK 140Z400M</b>		400										49.1	
<b>DK 160Z300M</b>	1,863 (190,000)	300	92.5	86	44.5	211.5	101.2	110.3	19	120	130	68.4	
<b>DK 160Z350M</b>		350										63.8	
<b>DK 160Z400M</b>		400										60.3	
<b>DK 200Z350M</b>	2,255 (230,000)	350	95	97	50.8	217.5	103.5	114	19	140	150	77.5	
<b>DK 200Z400M</b>		400										73.3	
<b>DK 200Z450M</b>		450										70.0	
<b>DK 250Z350M</b>	2,843 (290,000)	350	100	107	56	236	113	123	22	150	165	101.6	
<b>DK 250Z400M</b>		400										92.5	
<b>DK 250Z500M</b>		450										79.8	

## Dimensional Drawings: Strong Z-type Conveyor Chain with Attachment G4

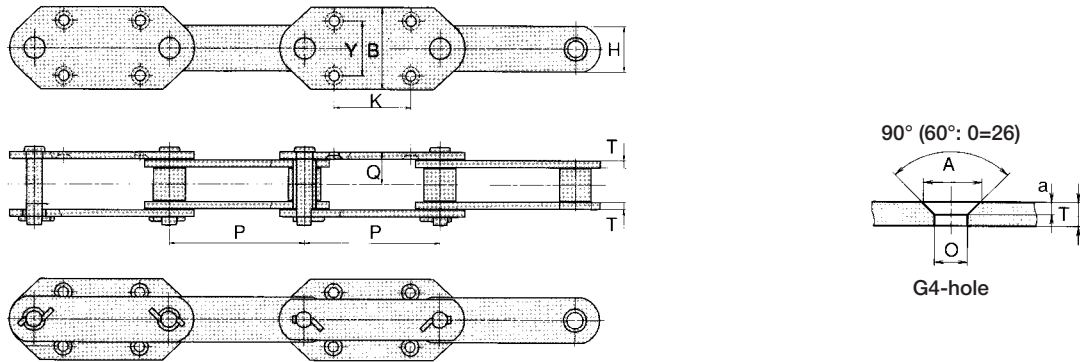

Connecting link (DK100Z or larger)

Chain No.	P	K	Y	B	O	A	a	T	Q	H	Bolt	Attachment weight (kg)
<b>DK 35Z200M</b>	200	100	80	125	14	27	6.5	9	45.5	57	M12	1.04
<b>DK 35Z250M</b>	250	140	100	150	18	33	7.5	9	48.5	75	M16	1.65
<b>DK 50Z200M</b>	200	100	80	125	18	33	7.5	9	48.5	75	M16	0.92
<b>DK 50Z225M</b>	225	120	80	125	18	33	7.5	9	48.5	75	M16	1.04
<b>DK 50Z250M</b>	250	140	100	150	18	33	7.5	9	48.5	75	M16	1.50
<b>DK 50Z300M</b>	300	170	100	150	18	33	7.5	9	48.5	75	M16	1.80
<b>DK 75Z200M</b>	200	100	80	125	18	33	7.5	12	60	90	M16	0.92
<b>DK 75Z250M</b>	250	140	100	150	18	33	7.5	12	60	90	M16	1.75
<b>DK 75Z300M</b>	300	170	100	150	18	33	7.5	12	60	90	M16	2.10
<b>DK 75Z350M</b>	350	225	100	150	18	33	7.5	12	60	90	M16	2.45
<b>DK 100Z250M</b>	250	140	100	150	22	39	8.5	16	72	100	M20	2.40
<b>DK 100Z300M</b>	300	170	120	180	22	39	8.5	16	72	100	M20	3.66
<b>DK 100Z350M</b>	350	225	120	180	22	39	8.5	16	72	100	M20	4.20
<b>DK 120Z250M</b>	250	140	120	180	22	39	8.5	16	76	115	M20	2.80
<b>DK 120Z300M</b>	300	170	120	180	22	39	8.5	16	76	115	M20	3.30
<b>DK 120Z350M</b>	350	225	120	180	22	39	8.5	16	76	115	M20	3.85
<b>DK 120Z400M</b>	400	260	140	210	22	39	8.5	16	76	115	M20	5.68
<b>DK 140Z300M</b>	300	170	140	210	26	42.2	14	16	77	125	M24	3.90
<b>DK 140Z350M</b>	350	225	140	210	26	42.2	14	16	77	125	M24	4.48
<b>DK 140Z400M</b>	400	260	140	210	26	42.2	14	16	77	125	M24	5.04
<b>DK 160Z300M</b>	300	170	140	210	26	42.2	14	19	87	130	M24	4.38
<b>DK 160Z350M</b>	350	225	140	210	26	42.2	14	19	87	130	M24	5.04
<b>DK 160Z400M</b>	400	260	140	210	26	42.2	14	19	87	130	M24	5.68
<b>DK 200Z350M</b>	350	200	180	250	26	42.2	14	19	88.5	150	M24	6.51
<b>DK 200Z400M</b>	400	260	180	250	26	42.2	14	19	88.5	150	M24	7.44
<b>DK 200Z450M</b>	450	290	180	250	26	42.2	14	19	88.5	150	M24	8.37
<b>DK 250Z350M</b>	350	200	180	250	26	42.2	14	22	97	165	M24	6.37
<b>DK 250Z400M</b>	400	260	180	250	26	42.2	14	22	97	165	M24	7.36
<b>DK 250Z500M</b>	500	320	180	250	26	42.2	14	22	97	165	M24	8.35

Note: Consult us for manufacturing other attachments and roller types.

## High Link-Plate Chain

This chain is the same as the Standard Multipurpose Conveyor Chain with a Roller R except for plates with elevated height. Loads can be set directly on these elevated plates.

### Application examples

- Conveyor lines for loads such as lumber and shaped steel in industrial plants like steel mills
- Assembly lines for automobiles etc.
- Pallets and conveyor lines for bulk containers.

### Dimensional Drawings: High Link-Plate Chain

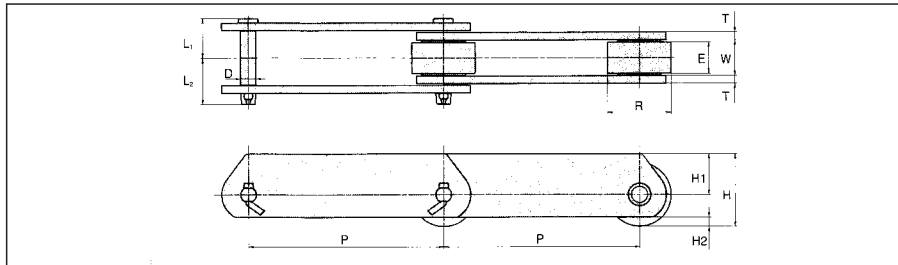

Unit (mm)

Chain No.	Avg. tensile strength				Pitch <b>P</b>	Width <b>W</b>	Roller		Chain height <b>H</b>	Plate			Pin			Roller allowable load kN/pc. (kgf/pc.)		Avg. weight (kg/m)
	Normal		Heavy duty				Diameter <b>R</b>	Width <b>E</b>		Thickness <b>T</b>	Height <b>H<sub>1</sub></b>	Height <b>H<sub>2</sub></b>	<b>D</b>	<b>L<sub>1</sub></b>	<b>L<sub>2</sub></b>	J-type	Normal/ Heavy duty	
	kN	kgf	kN	kgf														
<b>DK-HL03075R</b>					75													3.2
<b>DK-HL03100R</b>	34.3	3,500	69.3	7,100	100	15.9	30	14.6	36	3.2	21	4	7.94	16.7	20.4	0.53	0.88	2.7
<b>DK-HL03125R</b>					125					(3)						(55)	(90)	2.5
<b>DK-HL07075R</b>					75													6.2
<b>DK-HL07100R</b>	68.6	7,000	132	13,500	100	22.0	40	19	44	4.5	24	4	11	23.7	27.7	0.98	1.56	5.6
<b>DK-HL07125R</b>					125					(4)						(100)	(160)	5.2
<b>DK-HL09100R</b>					100													8.4
<b>DK-HL09125R</b>	88.2	9,000	156	16,000	125	25.6	45	22	50.5	6	28	6.5	12	29.6	34.5	1.37	2.25	7.6
<b>DK-HL09150R</b>					150											(140)	(230)	7.0
<b>DK-HL11100R</b>					100													10.9
<b>DK-HL11125R</b>	112	11,500	225	23,000	125	30.6	50	27	56	6	31	6	14	32.6	38.0	1.76	2.94	9.7
<b>DK-HL11150R</b>					150											(180)	(300)	8.8
<b>DK-HL19200R</b>					200													14.2
<b>DK-HL19250R</b>	186	19,000	279	28,500	250	36.5	65	32	74.5	8	42	9.5	15.9	40.4	47.1	2.45	4.11	12.9
<b>DK-HL19300R</b>					300											(250)	(420)	12.1
<b>DK-HL25200R</b>					200													22.2
<b>DK-HL25250R</b>	245	25,000	392	40,000	250	51.8	80	46	90	9	50	15	19.1	51.7	59.8	4.31	7.15	19.8
<b>DK-HL25300R</b>					300											(440)	(730)	18.3
<b>DK-HL32200R</b>					200													32.1
<b>DK-HL32250R</b>	313	32,000	500	51,000	250	57.6	100	51	107	9	57	17	22.2	55.7	62.8	5.39	8.92	28.4
<b>DK-HL32300R</b>					300											(550)	(910)	25.7
<b>DK-HL50250R</b>					250													49.0
<b>DK-HL50300R</b>	490	50,000	686	70,000	300	67.4	125	58	132.5	12	70	22.5	25.4	68.1	74.9	7.45	12.3	44.2
<b>DK-HL50450R</b>					450											(760)	(1,260)	36.3
<b>DK-HL05101R</b>	53.9	5,500	98	10,000	101.6	22.2	38.1	19	44	4.5	25	4	9.7	23.3	27.3	0.98	1.66	5.1
																(100)	(170)	
<b>DK-HL08101R</b>	78.4	8,000	142	14,500	101.6	27.6	44.5	24	50.2	6	28	6.2	11.3	30.1	35.0	1.27	2.15	8.4
																(130)	(220)	
<b>DK-HL11152R</b>	112	11,500	171	17,500	152.4	30.8	50.8	27	56.4	6	31	6.4	12.7	32.2	37.6	1.66	2.84	8.6
																(170)	(290)	
<b>DK-HL13101R</b>	127	13,000	240	24,500	101.6	31.0	44.5	27	53.5	8	31	3.5	15.9	37.6	44.4	2.05	3.43	12.0
																(210)	(350)	
<b>DK-HL19152R</b>	186	19,000	279	28,500	152.4	36.5	57.2	32	65.5	8	37	5.6	15.9	40.4	47.1	2.45	4.07	13.8
																(250)	(410)	
<b>DK-HL25152R</b>	245	25,000	392	40,000	152.4	37.5	69.9	33	79.9	9	45	10	19.1	44.6	52.9	3.04	5.09	19.6
																(310)	(520)	

Note: 1. T values in ( ) are for stainless steel type. Values in columns without ( ) apply to all types.  
 2. Pins of DK-HL03075~DK-HL-03125R are rivet shaped excluding the connecting parts.  
 3. Ask us for delivery time.

## Conveyor Chain with Side Roller

This chain is made of a Standard Multipurpose Conveyor Chain with a Roller S with longer pins and with a side roller with flanges on both sides. Sprockets engage at the center of the roller and it runs by the side rollers. It can be manufactured with materials of a Standard Multipurpose Conveyor Chain.

## For ordering

Specify the chain number and the interval between the chain and the side roller.

## Application examples

- When modifying plates into specific shapes for attaching devices like docks or top-plates.
- When it is impossible to support the chain load at the center of the roller
- To steadily convey loads with high gravitational center.
- When attaching uplift guides prevention on chains.

## Dimensional Drawings: Conveyor Chain with Side Roller

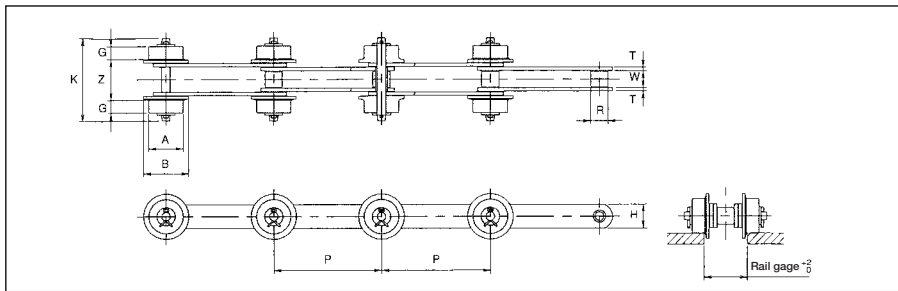

Unit (mm)

Chain No.	Pitch <b>P</b>	Roller (bush) dia. <b>R</b>	Roller link width <b>W</b>	Plate		Side roller			<b>K</b>	<b>Z</b>	Rail gage	Approx. additional weight per side roller (kg)
				Thickness <b>T</b>	Width <b>H</b>	<b>A</b>	<b>B</b>	<b>G</b>				
<b>DK 03075S-SR</b> <b>DK 03100S-SR</b>	75 100	15.9	15.9	3.2	22.2	30	40	12	76	38	40	0.3
<b>DK 05101S-SR</b>	101.6	20.1	22.2	4.5	25.4	40	50	15	102	55	57	0.6
<b>DK 07075S-SR</b> <b>DK 07100S-SR</b> <b>DK 07150S-SR</b>	75 100 150	22.2	22	4.5	32	40	50	15	102	55	57	0.6
<b>DK 08101S-SR</b>	101.6	22.2	27.6	6	28.6	45	60	16	120	70	72	0.8
<b>DK 11100S-SR</b> <b>DK 11150S-SR</b>	100 150	28.8	30.6	6	38	50	65	20	133	75	77	1.2
<b>DK 19152S-SR</b>	152.4	34.9	36.5	8	45	60	80	24	165	92	94	1.8
<b>DK 19200S-SR</b> <b>DK 19250S-SR</b>	200 250	34.9	36.5	8	45	65	85	24	165	92	94	2.0
<b>DK 25200S-SR</b> <b>DK 25250S-SR</b> <b>DK 25300S-SR</b>	200 250 300	40.1	51.8	9	50	65	85	24	186	112	114	2.0
<b>DK 32200S-SR</b> <b>DK 32250S-SR</b> <b>DK 32300S-SR</b>	200 250 300	44.5	57.6	9	65	80	100	35.5	222	124	126	4.8
<b>DK 50250S-SR</b> <b>DK 50300S-SR</b> <b>DK 50450S-SR</b>	250 300 450	50.8	67.4	12	80	100	125	39	260	150	152	8.4

Note: 1. The basic specifications of the chain are identical to that of Standard Multipurpose Conveyor Chain.  
2. Ask us for delivery time.

## Conveyor Chain with Top Roller

As shown in the figure, rollers are attached on the top of the chain for conveying pallets loaded with products. The pallets travel with the roller, but can be stopped by stoppers. The chain continues to run but the top rollers run idle; commonly known as the "chain for free flow conveyor". There are two types to the Conveyor Chain with Top Roller: TR1 and TR2. The chain body is based on a Standard Multipurpose Conveyor Chain.

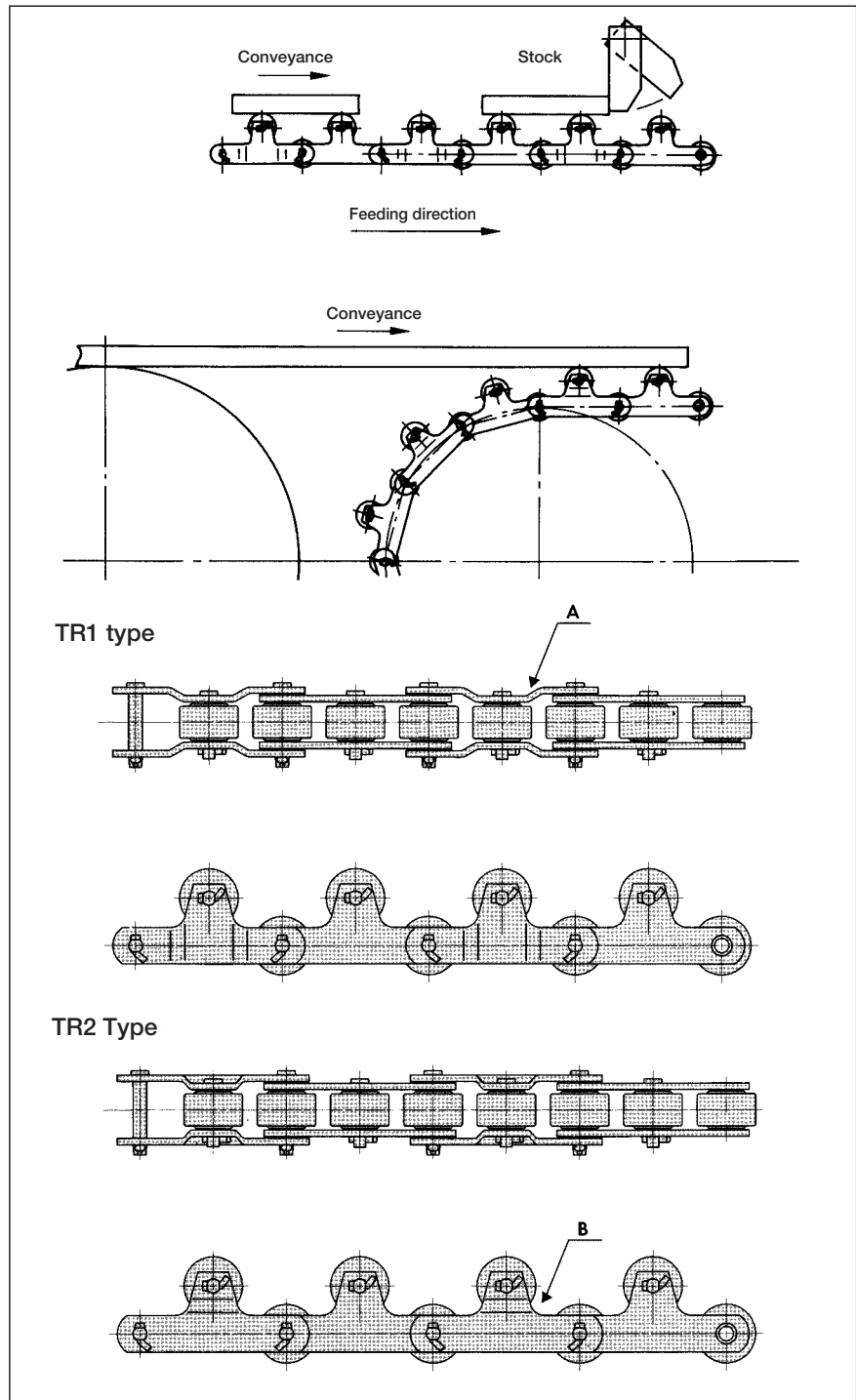

TR1 type: Plates are bent at A as shown in the figure to unify the space between the facing plates to the width of the top roller.

TR2 type: Plates bent at B as shown in the figure.



## Conveyor Chain Exclusive for Specific Conveyance

The previous section describes that by combining with various attachments, the DK Conveyor Chains can be used for almost all general applications. This section describes the DK Specialty Conveyor Chains developed based on the Standard Conveyor Chain. Specialty Conveyor Chains offer improved form, size series and material advantages that suit respective applications. They can be classified into three types: Specialized Application Conveyor Chain, Water Treatment Conveyor Chain, and 3D Bending Conveyor Chain.

## Conveyor Chain with Attachments for Conveying Bulk Materials

### Continuous Flow Conveyor Chain and Chain for Dust Conveyor

As shown in the photo, a chain with blades is operated in a powder to cause the powder to flow in the same direction as the feeding direction of the chain. This is called a Continuous Flow Conveyor Chain. The same type of chain is also used in a similar way for discharging the dust generated by various dust collectors. We manufacture 25 types of Standard Conveyor Chains with blades, two types of Block Chains with blades (P.284), respectively suitable for the various properties of dusts and powders, and five chains with special cast steel blades for conveying powders likely to cause wear. The respective chains are designated as follows:

- |                                      |   |   |
|--------------------------------------|---|---|
| Standard Conveyor Chains with blades | → | Continuous Flow Conveyor Chain or Chain for Dust Conveyor |
| Block Chains with blades             | → | Block Chain for Dust Conveyor                             |
| Chain with special cast steel blades | → | TA Type Drag Chain  |

We manufacture continuous flow conveyors and dust conveyors using the above chains with blades as standard equipment. Consult us for further details.

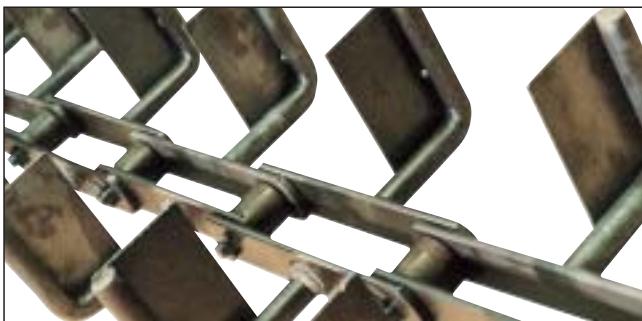

DK Specialty Conveyor Chains

Specialized Application Conveyor Chain

### (a) Continuous Flow Conveyor Chain

Continuous Flow Conveyor Chains are used for our standard continuous flow conveyors. Depending on the conveyed subjects, the following three types of attachments are available. The basic chain can be either a Standard Conveyor Chain or a Strong H-type Conveyor Chain.

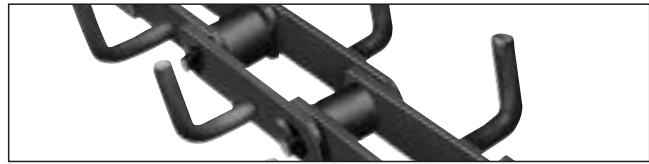

Type of attachment	Shape	Application
<b>L</b>		For the conveyance of bulk materials such as grain like wheat and powder like cement.
<b>KL</b>		For the conveyance of adhesive bulk material.
<b>B</b>		For the conveyance of bulk material like cement with higher feeding efficiency than Attachment L.

Chain No.	Type	Conveyor No.	Avg. tensile strength				Pitch P	Roller link			Pin			Plate		Approx. weight without attachment (kg/m)	Attachment		Approx. weight with Attachment B (kg/m)	Approx. weight with Attachment L or KL (kg/m)
			Standard A		Heavy-duty K			width W	dia. R	D	L1	L2	T	H	X		Y			
			kN	kgf	kN	kgf														
※DK 091015	Standard	U-150	88.2	9,000	156	16,000	101.6	27.6	26.5	12.7	30.6	36	6	32	5.4	135	60	7.2	6.5	
DK 191525		U-200	186	19,000	279	28,500	152.4	36.5	34.9	15.9	40.4	47.1	8	45	9.1	175	80	11.6	11.2	
DK 192005		U-270	186	19,000	279	28,500	200	36.5	34.9	15.9	40.4	47.1	8	45	8.4	245	110	12.4	11.5	
		U-350														325	140	15.5	12.7	
DK 252005		U-270	245	25,000	392	40,000	200	51.8	40.1	19.1	51.7	59.8	9	50	11.4	245	110	15.2	14.6	
		U-350														325	140	18.5	15.7	
		U-430														400	170	20.5	16.8	
DK 322005		U-350	313	32,000	500	51,000	200	57.6	44.5	22.2	55.7	62.8	9	65	15.5	325	140	22.5	22.6	
		U-430														400	170	24.5	23.6	
DK 322505		U-500	313	32,000	500	51,000	250	57.6	44.5	22.2	55.7	62.8	9	65	14.4	470	200	25.6	23.5	
DK 502505		U-500	490	50,000	686	70,000	250	67.4	50.8	25.4	68.1	74.9	12	80	24.1	470	200	35.0	34.0	
DK 503005		U-600	490	50,000	686	70,000	300	67.4	50.8	25.4	68.1	74.9	12	80	22.4	570	240	33.8	33.1	
DK 50H200M		U-430			490	50,000	200	57.6	50.8	25.4	57.3	64.2	9	65	17	400	170	26.1	22.4	
DK 75H200M		U-430			735	75,000	200	67.4	63.5	31.75	70	78	12	80	30	400	170	39.0	35.3	
DK 75H250M		U-500			735	75,000	250	67.4	63.5	31.75	70	78	12	80	27	470	200	37.9	36.9	
DK 75H300M	U-600			735	75,000	300	67.4	63.5	31.75	70	78	12	80	25	570	240	36.4	37.3		
DK 100H250M	U-500			980	100,000	250	75	70	35	83.2	90.8	16	90	41.2	470	200	51.9	51.0		
DK 100H300M	U-600			980	100,000	300	75	70	35	83.2	90.8	16	90	38.2	570	240	49.5	50.3		
DK 100H350M	U-700			980	100,000	350	75	70	35	83.2	90.8	16	90	35.9	670	280	50.2	49.7		
DK 120H300M	U-600			1,176	120,000	300	82.5	75	38.5	88	95.5	16	100	44.8	570	240	55.8	59.9		
DK 120H350M	U-700			1,176	120,000	350	82.5	75	38.5	88	95.5	16	100	41.8	670	280	56.0	55.5		
DK 140H350M	U-700			1,372	140,000	350	85	82	41.75	90.2	99.3	16	115	50.5	670	280	64.5	64.0		
DK 160H350M	U-700			1,569	160,000	350	92.5	86	44.5	101.2	110.3	19	120	62.8	670	280	74.0	78.1		

Note: 1. Chains marked with ※ should not be used for the conveyance of materials causing wear and the conveyance of loads with frequently fluctuating volume.  
2. Ask us for the delivery time.

DK Specialty Conveyor Chains  
Specialized Application Conveyor Chain

**Shapes and Indications of Attachments**

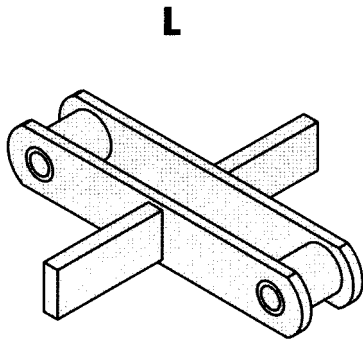

For conveying highly adhesive powder

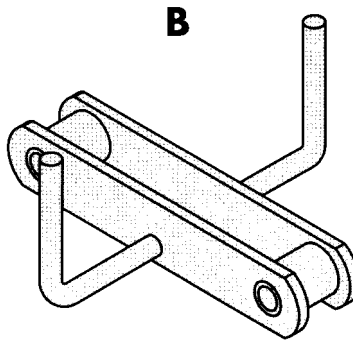

For conveying moderately adhesive powder

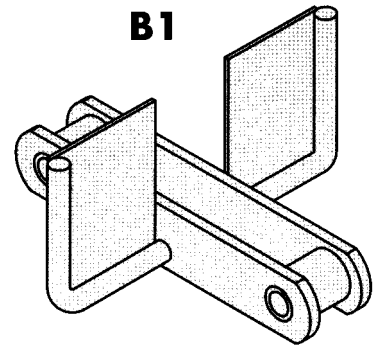

For conveying slightly adhesive powder on an ascending slope, or for conveying articles likely to float.

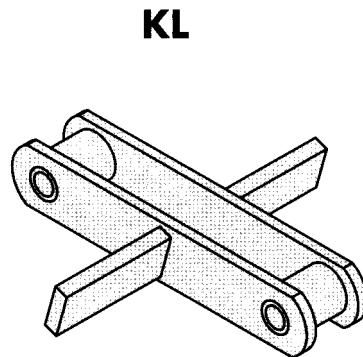

For conveying highly adhesive powder containing granular material

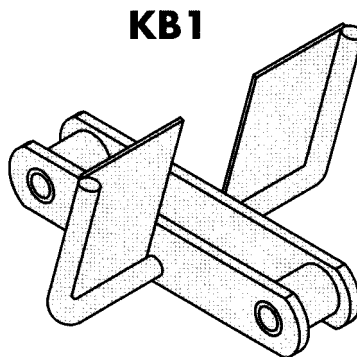

For conveying moderately adhesive powder containing some granular material

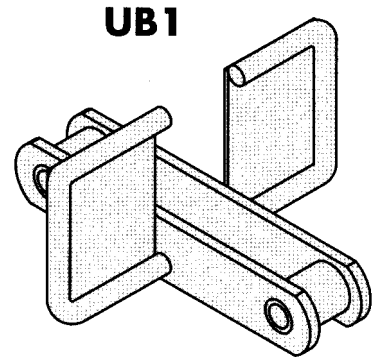

For conveying slightly adhesive powder in a large conveyor

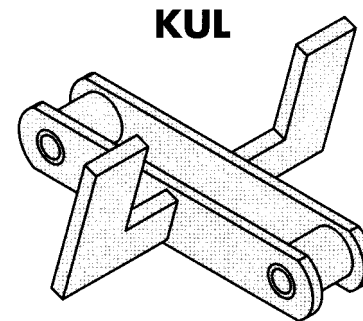

For conveying slightly adhesive powder containing a large amount of granular material

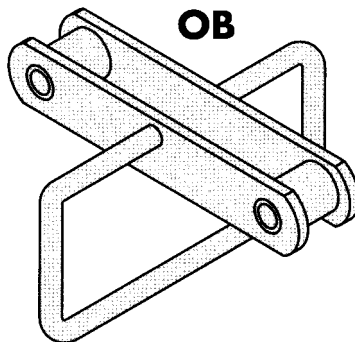

For a vertical or highly inclined conveyor such as Conveyor L or S

**Indication**

1. An attachment is indicated by a hyphen added after the symbol of tensile strength grade. However, in the case of a strong type conveyor chain, an attachment is indicated by adding a hyphen after the roller type.

Example) **DK19152S-K-L**

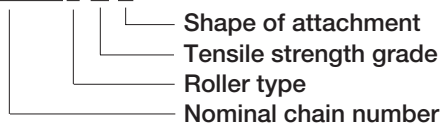

Example) **DK75H200M-L**

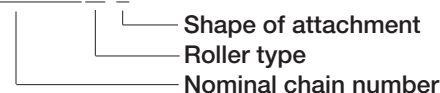

2. In the case of an inclined attachment, "K" is added before the attachment symbol.

Example) **DK19152S-A-KL**  
**DK75H200M-KUL**

3. When an attachment has a steel sheet or rib, etc. as an accessory, "1" is added at the end.

Example) **DK19152S-E-B1**  
**DK75H200M-KB1**

DK Specialty Conveyor Chains

Specialized Application Conveyor Chain

## (b) Chains for Dust Conveyor

This chain is used for conveyors exclusively for carrying dust. Depending on the application, the following three types are available:

- 1) Roller S Conveyor Chain for low density powder with Attachment B or B1 for U and LU Type Dust Conveyors
  - 2) Roller M Conveyor Chain for medium density powder with Attachment KL or KUL for DU, DU-S, LDU and LDU-S Type Dust Conveyors
  - 3) Block Chain for highly abrasive powder with KL or KUL attachments for DUB, DUB-S LDUB and LDUB-S Type Dust Conveyors
- Select optimal chains depending on the specifications of the dust conveyors.



### Conveyor chains for U, LU type dust conveyor

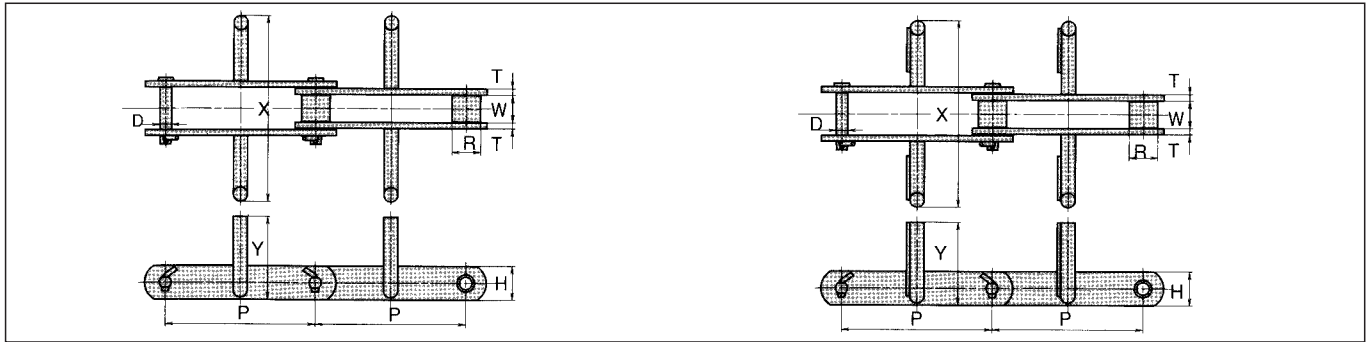

Chain No.	Type of DK dust conveyor	Avg. tensile strength kN (kgf)	Pitch <b>P</b>	Roller link width <b>W</b>	Roller outside dia. <b>R</b>	Pin <b>D</b>	Plate		Blade width		Blade height		Approx. weight (kg/m)	
							<b>T</b>	<b>H</b>	<b>X</b>	<b>Y</b>	With Attachment <b>B</b>	With Attachment <b>B1</b>		
<b>DK 19152S</b>	U-200	186 (19,000)	152.4	36.5	34.9	15.9	8	45	175	80	11.5	—	11.5	—
	LU-200										—	—		
<b>DK 19200S</b>	U-270	186 (19,000)	200	36.5	34.9	15.9	8	45	245	110	12.2	—	—	—
	LU-270										—	13.3		
<b>DK 25200S</b>	U-270	245 (25,000)	200	51.8	40.1	19.1	9	50	245	110	15.7	—	—	—
	LU-270										—	16.8		
	U-350								325	140	19.0	—	—	—
<b>DK 32200S</b>	U-350	313 (32,000)	200	57.6	44.5	22.2	9	65	325	140	23.3	—	—	—
	LU-350										—	25.8		

Unit (mm)

### Conveyor chain for DU, DU-S, LDU-S type dust conveyors

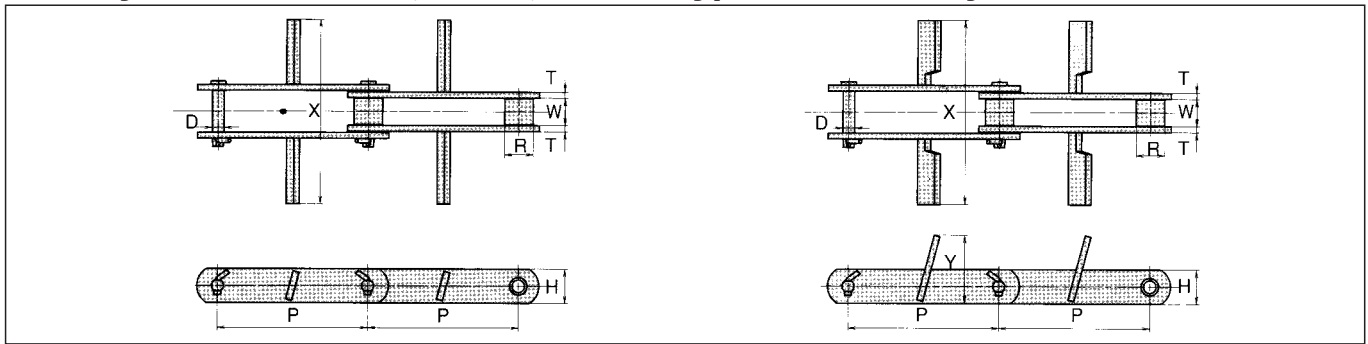

Chain No.	Type of DK dust conveyor	Avg. tensile strength kN (kgf)	Pitch <b>P</b>	Roller link width <b>W</b>	Roller outside dia. <b>R</b>	Pin <b>D</b>	Plate		Blade width <b>X</b>	Approx. weight (kg/m)	
							<b>T</b>	<b>H</b>		With Attachment <b>KL</b>	With Attachment <b>KUL</b>
<b>DK 19152M</b>	DU-200	279 (28,500)	152.4	36.5	38.1	15.9	8	45	185	11.2	—
	DU-200S									11.2	—
	LDU-200									—	12.6(Y=65)13.8(Y=90)
	LDU-200S									—	12.6(Y=65)13.8(Y=90)
	DU-250									12.2	—
DU-250S	12.2	—									
	LDU-250	—	13.9(Y=65)17.0(Y=110)								
	LDU-250S	—	13.9(Y=65)17.0(Y=110)								
<b>DK 25200M</b>	DU-310	392 (40,000)	200	51.8	44.5	19.1	9	50	290	15.0	—
	DU-310S									15.0	—
	LDU-310									—	20.0(Y=110)22.2(Y=140)
	LDU-310S									—	20.0(Y=110)22.2(Y=140)
	LDU-310S									—	—

Note: 1. The blade dimensions (X, Y) can be changed upon request. 2. Ask us for delivery time.

**Block Chains for DUB, DUB-S, LDUB, LDUB-S type dust conveyor**

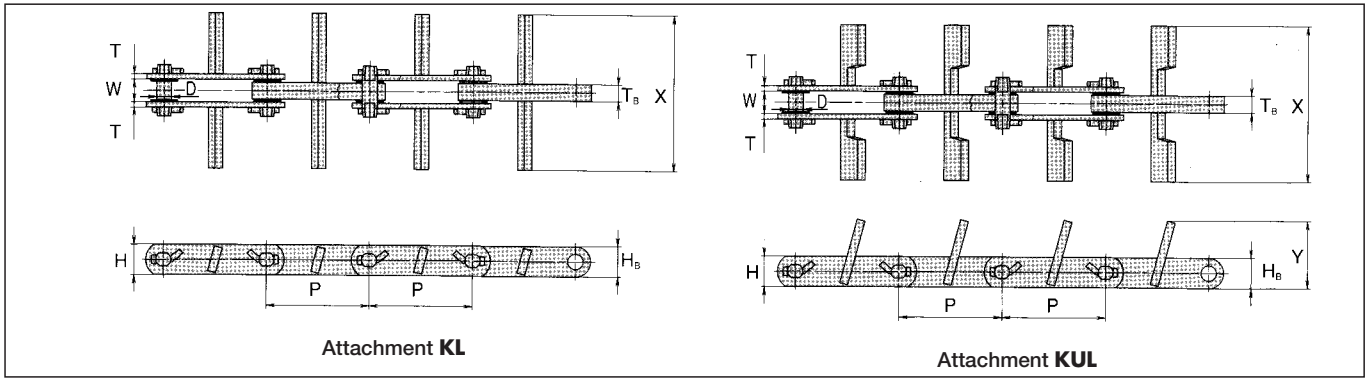

Unit (mm)

Chain No.	Type of DK dust conveyor	Avg. tensile strength		Pitch P	Roller link width W	Pin D	Outer plate			Block T <sub>b</sub>	Wing width H <sub>b</sub>	X	Approx. weight (kg/m)	
		kN	kgf				T	H	With Attachment KL				With Attachment KUL	
DK 30B150	DUB-200	294	30,000	152.4	33.3	22	8	45	25	45	180	13.5	—	
	DUB-200S											13.5	—	
	LDUB-200											—	14.5 (Y=65) 16.0 (Y=90)	
	LDUB-200S											—	14.5 (Y=65) 16.0 (Y=90)	
	DUB-250											14.5	—	
	DUB-250S											14.5	—	
LDUB-250	—	16.5 (Y=65) 19.5 (Y=100)												
LDUB-250S	—	16.5 (Y=65) 19.5 (Y=100)												
DK 40B150	DUB-310	392	40,000	152.4	40.8	25.2	9	50	32	50	290	20.0	—	
	DUB-310S											20.0	—	
	LDUB-310											—	22.3 (Y=65) 27.8 (Y=110)	
	LDUB-310S											—	22.3 (Y=65) 27.8 (Y=110)	
DK 40B200	DUB-400	392	40,000	200	40.8	25.2	9	50	32	50	380	19.6	22.0 (Y=65) 27.9 (Y=110)	

**Driving Sprocket**  
(Block Chains for dust conveyors)

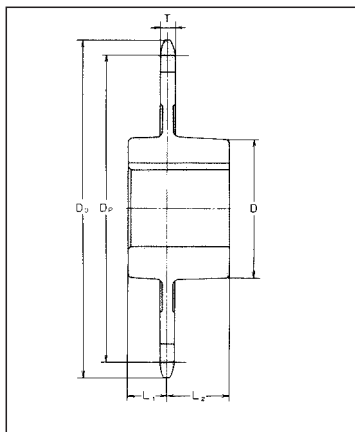

**Driven Sprocket**  
(Block Chains for dust conveyors)

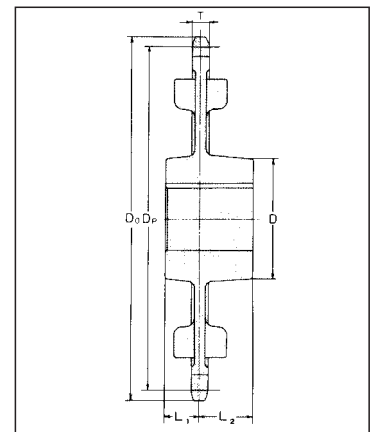

**Dimensions**

Unit (mm)

Sprocket size	No. of teeth (for single pitch)	Chain pitch	Pitch dia. D <sub>p</sub>	Outer dia. D <sub>o</sub>	Tooth width T	Range of axle dia.	
						Over	≤
DK 30B150	4 (8)	152.4	398.2	430	22	50	145
	5 (10)						
DK 40B150	4 (8)	152.4	398.2	435	28	50	145
	5 (10)						
DK 40B200	4 (8)	200	522.4	560	28	50	145
	5 (10)						

**Hub dimensions**

Sprocket size	Range of axle dia.		Hub dimensions		
	Over	≤	D	L <sub>1</sub>	L <sub>2</sub>
DK 30B150	50	65	110	30	45
	65	85	140	40	60
DK 40B150	85	110	180	50	80
	110	130	205	70	100
DK 40B200	130	145	225	70	100

[Type indication] **DK 30B150- 4 No.d** For driving sprocket  
Sprocket size No. of teeth Axle hole dimension

Note: 1. For the axle hole dimension, please refer to pages describing axle diameters and hub dimensions.  
2. Ask us for the delivery time.

**Dimensions**

Unit (mm)

Sprocket size	No. of teeth (for single pitch)	Chain pitch	Pitch dia. D <sub>p</sub>	Outer dia. D <sub>o</sub>	Tooth width T	Range of axle dia.	
						Over	≤
DK 30B150	4 (8)	152.4	398.2	420	22	50	110
	5 (10)						
DK 40B150	4 (8)	152.4	398.2	422	28	50	110
	5 (10)						
DK 40B200	4 (8)	200	522.4	547	28	50	110
	5 (10)						

**Hub dimensions**

Sprocket size	Range of axle dia.		Hub dimensions		
	Over	≤	D	L <sub>1</sub>	L <sub>2</sub>
DK 30B150	50	65	110	30	45
	65	85	140	40	60
DK 40B150	85	110	180	50	80

[Type indication] **DK 30B150- 4 No.d** For driven sprocket  
Sprocket size No. of teeth Axle hole dimension

Note: 1. For the axle hole dimension, please refer to pages describing axle diameters and hub dimensions.  
2. Ask us for the delivery time.

DK Specialty Conveyor Chains  
Specialized Application Conveyor Chain



## Eco Slight (small sized apron conveyor chain) Hinge Type

### Compared to Flat Pan Type Conveyor Chain, Eco Slight has the following features.

- Flexibility in application to equipment and work space**  
 Various patterns of attachment to equipment and lay out in work space are possible.
- Less trouble with conveyance**  
 Seizing of loads hardly occurs during conveyance.
- Easy maintenance**  
 The apron can be replaced just by detaching the pins of the side chain.

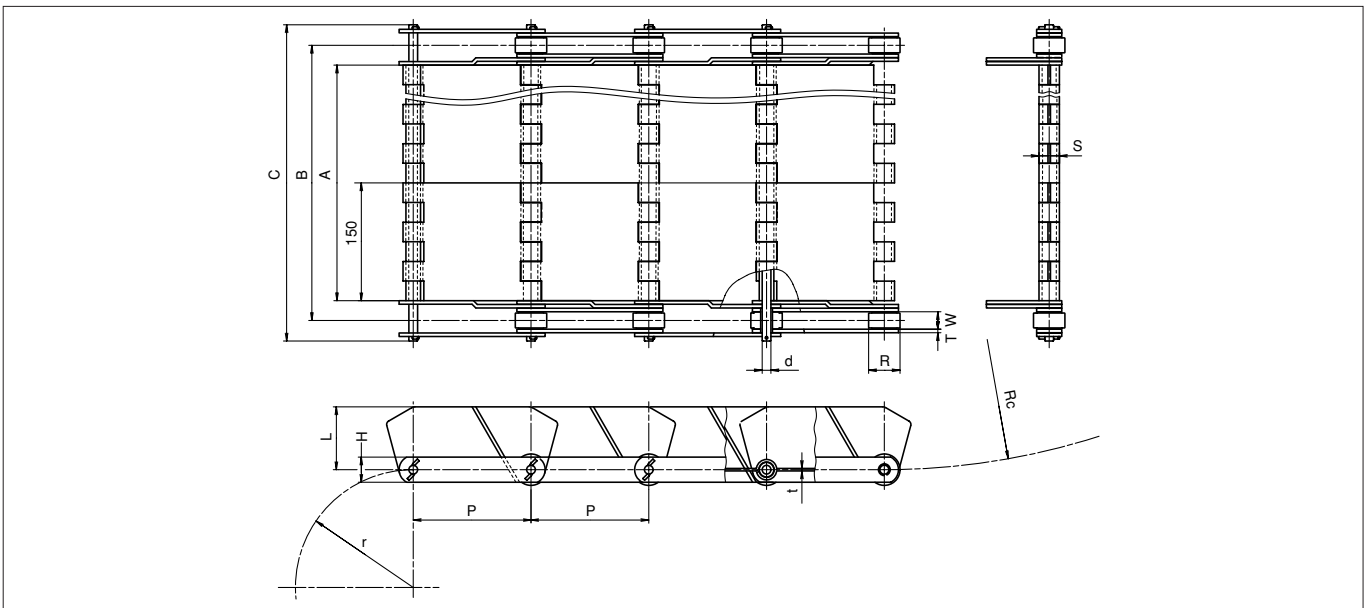

### Dimensions

Unit (mm)

Conveyor No.	Conveyor											Side chain						
	Apron width <b>A</b>	Center distance <b>B</b>	Outer width <b>C</b>	Wing height <b>L</b>	Hinge plate thickness <b>t</b>	Hinge <b>S</b>	Min. flexibility		Avg. tensile strength		Approx. weight (kg/m)	Side chain No.	Pitch <b>P</b>	Roller outer dia. <b>R</b>	Roller link width <b>W</b>	Plate		Pin dia. <b>d</b>
							Upper radius <b>Rc</b>	Lower radius <b>r</b>	kN	kgf						Height <b>H</b>	Thickness <b>T</b>	
DEC 3075-150	150	188.4	227.3															
DEC 3075-300	300	338.4	377.3	40	2.0	16.4	300	75	58.8	6,000	17.5	DK03075R	75	30	18	22	3.2	7.94
DEC 3075-450	450	488.4	527.3															
DEC 3100-150	150	188.4	227.3															
DEC 3100-300	300	338.4	377.3	60	2.0	16.4	450	100	58.8	6,000	16.9	DK03100R	100	30	18	22	3.2	7.94
DEC 3100-450	450	488.4	527.3															
DEC 7150-150	150	200.4	252.7															
DEC 7150-300	300	350.4	402.7															
DEC 7150-450	450	500.4	552.7	80	3.2	26.0	900	150	137.3	14,000	32.2	DK07150R	150	40	22.2	32	4.5	11.11
DEC 7150-600	600	650.4	702.7															
DEC 7150-750	750	800.4	852.7															

- Note: 1. Consult us if roller width (A) is wider than above values.  
 2. F-Roller (flange type) is available.  
 3. Hinge plate thickness with thicker dimensions than above values can be manufactured.  
 4. Tensile strength higher than DEC7000 and specified pitch numbers other than the above can be manufactured.  
 5. Cleat (catcher rail for dropped load) can be attached.

[Type indication]      Conveyor No.      Quantity of components (※)

DEC 3075-150 ; 100 WL

Eco Slight / Conveyor chain      Side Chain No. DK03075R      Unit      Pitch number

Apron width

(※) 100WL indicates a composition of 100 links each for both sides of the side chain, 100 pins and 100 aprons.

## Chain for Garbage Conveyor

This conveyor chain is recommended for apron conveyors, scraper conveyors, and other systems conveying industrial waste in a recycle center, household refuse or ash in an incineration plant. It is designed to prevent interference with chain rotation even when various loads enter into the roller bearing.

In addition to standard chains, custom-made chains with enhanced wear resistance and corrosion resistance to meet the requirements of specific uses can be manufactured upon request.

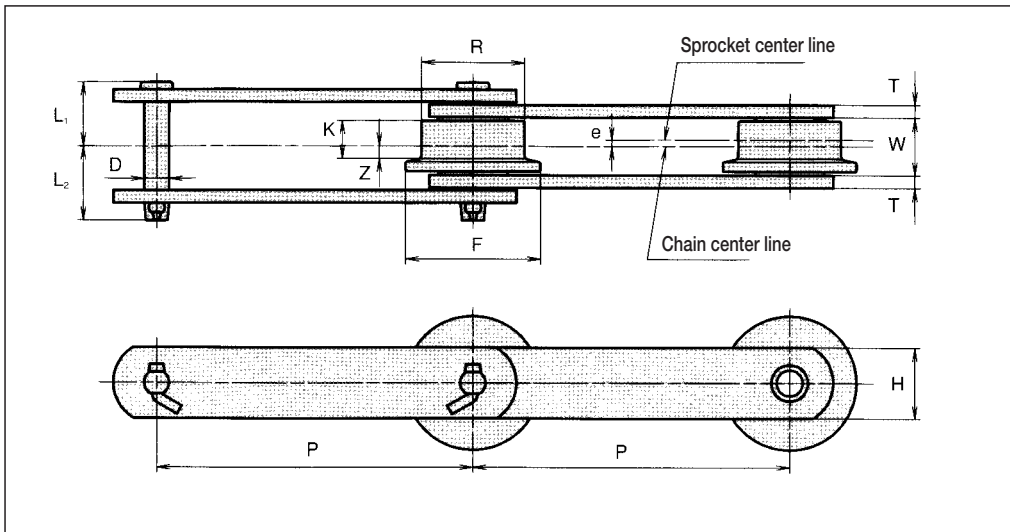

### Dimensions

Chain No.	Avg. tensile strength		Pitch <b>P</b>	Roller link width		Roller					Pin			Plate		Approx. weight (kg/m)
	kN	kgf		<b>W</b>	<b>R</b>	<b>F</b>	<b>K</b>	<b>e</b>	<b>Z</b>	<b>D</b>	<b>L<sub>1</sub></b>	<b>L<sub>2</sub></b>	<b>T</b>	<b>H</b>		
<b>DK 11125UF</b> <b>DK 11150UF</b>	112	11,500	125 150	30.6	50	65	20	3.5	6.5	14	32.6	38.0	6	38	8.9 7.9	
<b>DK 19200UF</b> <b>DK 19250UF</b>	186	19,000	200 250	36.5	65	85	24	4	8	15.9	40.4	47.1	8	45	12.1 10.8	
<b>DK 25200UF</b> <b>DK 25250UF</b> <b>DK 25300UF</b>	245	25,000	200 250 300	51.8	80	105	35.5	5	12.5	19.1	51.7	59.8	9	50	19.5 17.0 15.3	
<b>DK 32250UF</b> <b>DK 32300UF</b>	313	32,000	250 300	57.6	100	130	39	6	13.5	22.2	55.7	62.8	9	65	26.2 23.4	
<b>DK 50300UF</b> <b>DK 50450UF</b>	490	50,000	300 450	67.4	125	160	44	7	15	25.4	68.1	74.9	12	80	40.4 31.9	

Note: 1. It is possible to manufacture chains with roller types other than UF and with specific attachments.  
 2. The dimension for the sprocket used for this chain is identical to that of the Roller F type. (Please see P.315)  
 3. Ask us for the delivery time.

DK Specialty Conveyor Chains  
Specialized Application Conveyor Chain



# Bucket Elevator Chains

A bucket elevator is a conveyor in which buckets are installed on a vertically circulating chain, to vertically convey loads of granular powder. There are two series of bucket elevators: NE Type (standard speed) and NSE Type (high speed). Both types have wide-ranging applications.

## (a) NE Bucket Elevator Chains

An NE type bucket elevator is a general-use bucket elevator that operates at a normal conveyance speed. The elevator is manufactured with two types of chains: Standard Conveyor Chain with Attachment G4 (standard or heavy-duty) and DK Strong Z Conveyor Chain.

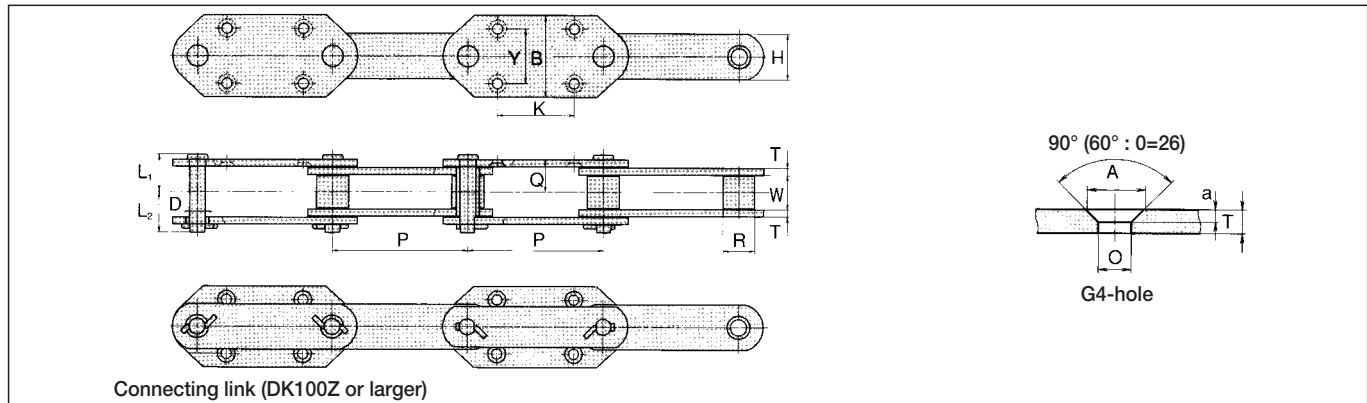
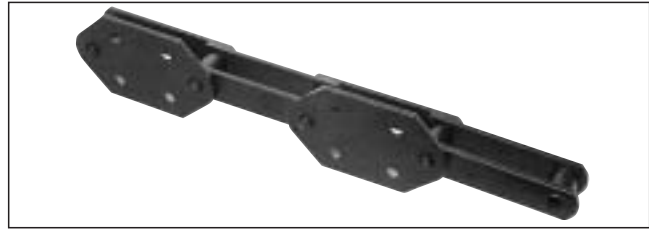

Chain No.	Type	Avg. tensile strength kN (kgf)		Pitch P	Roller link width W	Roller dia. R	Pin			Plate		Attachment						Flush bolt	Approx. weight (kg/m)	
		Standard	Heavy-duty				D	L <sub>1</sub>	L <sub>2</sub>	T	H	K	Y	B	O	A	Q		Without attachment	With Attachment G4
<b>DK 19200M</b> <b>DK 19250M</b>	Standard	186 (19,000)	279 (28,500)	200 250	36.5	38.1	15.90	40.4	47.1	8	45	100	80	125	14	27	35.5	M12	8.6 8.1	11.0 10.5
<b>DK 25200M</b> <b>DK 25250M</b>		245 (25,000)	392 (40,000)	200 250	51.8	44.5	19.10	51.7	59.8	9	50	100 140	80	125	14	27	45.5	M12	11.9 11.0	14.6 13.7
<b>DK 32200M</b> <b>DK 32250M</b> <b>DK 32300M</b>		313 (32,000)	500 (51,000)	200 250 300	57.6	50.8	22.20	55.7	62.8	9	65	100 140 170	80	125	18	33	48.5	M16	16.4 15.2 14.2	18.7 18.2 17.2
<b>DK 50250M</b> <b>DK 50300M</b>		490 (50,000)	686 (70,000)	250 300	67.4	57.1	25.40	68.1	74.9	12	80	140 170	100	150	18	33	60	M16	25.2 23.3	28.7 26.8
<b>DK 65300M</b>		588 (60,000)	882 (90,000)	300	75	63.5	28.00	81.2	88.8	16	75	170	100	160	22	39	72	M20	30.1	34.8
<b>DK 11152M</b>		112 (11,500)	171 (17,500)	152.4	30.8	28.6	12.70	31.7	36.6	6	38	75	70	110	12	22	28.5	M10	5.8	7.4
<b>DK 19152M</b>		186 (19,000)	279 (28,500)	152.4	36.5	38.1	15.90	40.4	47.1	8	45	75	70	110	14	27	35.5	M12	9.4	11.4
<b>DK 25152M</b>		245 (25,000)	392 (40,000)	152.4	37.5	44.5	19.10	44.6	52.9	9	50	75	70	125	14	27	38.5	M12	12.6	15.2
<b>DK 352200M</b> <b>DK 352250M</b>		—	392 (40,000)	200 250	51.8	44.5	22.20	53.8	60.2	9	57	100 140	80	125	14	27	45.5	M12	12.7 11.7	15.3 15.0
<b>DK 502200M</b> <b>DK 502225M</b> <b>DK 502250M</b> <b>DK 502300M</b>		—	588 (60,000)	200 225 250 300	57.6	50.8	25.40	57.3	64.2	9	75	100 120 140 170	80	125	18	33	48.5	M16	17.7 16.9 16.2 15.2	20.0 19.2 19.2 18.2
<b>DK 752200M</b> <b>DK 752250M</b> <b>DK 752300M</b> <b>DK 752350M</b>	—	931 (95,000)	200 250 300 350	67.4	63.5	31.75	70.0	78.0	12	90	100 140 170 225	80	125	18	33	60	M16	31.0 28.0 26.0 24.6	33.3 31.5 29.5 28.1	
<b>DK 100Z250M</b> <b>DK 100Z300M</b> <b>DK 100Z350M</b>	Strong Z-type	—	1,225 (125,000)	250 300 350	75.0	70.0	35.00	83.2	90.8	16	100	140 170 225	100	150	18	33	72	M16 M20	42.5 39.5 37.2	47.3 45.6 43.2
<b>DK 120Z250M</b> <b>DK 120Z300M</b> <b>DK 120Z350M</b> <b>DK 120Z400M</b>		—	1,470 (150,000)	250 300 350 400	82.5	75.0	38.50	88.0	95.5	16	115	140 170 225 260	120	180	18	33	76	M16 M20	50.6 46.8 43.7 41.6	56.2 52.3 49.2 48.7
<b>DK 140Z300M</b> <b>DK 140Z350M</b> <b>DK 140Z400M</b>		—	1,667 (170,000)	300 350 400	85.0	82.0	41.75	90.2	99.3	16	125	170 225 260	140	210	26	42.2	77	M24	55.5 51.8 49.1	62.0 58.2 55.4
<b>DK 160Z300M</b> <b>DK 160Z350M</b> <b>DK 160Z400M</b>		—	1,863 (190,000)	300 350 400	92.5	86.0	44.50	101.2	110.3	19	130	170 225 260	140	210	26	42.2	87	M24	68.4 63.8 60.3	75.7 71.0 67.4
<b>DK 200Z350M</b> <b>DK 200Z400M</b> <b>DK 200Z450M</b>		—	2,255 (230,000)	350 400 450	95.0	97.0	50.80	103.3	114.0	19	150	200 260 290	180	250	26	42.2	88.5	M24	77.5 73.3 70.0	86.8 82.6 79.3
<b>DK 250Z350M</b> <b>DK 250Z400M</b>		—	2,843 (290,000)	350 400	100.0	107.0	56.00	113.0	123.0	22	165	200 260	180	250	26	42.2	97	M24	101.6 92.5	110.7 101.7

Note: Ask us for the delivery time.

DK Specialty Conveyor Chains  
Specialized Application Conveyor Chain

**(b) NSE Bucket Elevator Chains**

An NSE type bucket elevator is designed for high speed conveyance and the speed is about double that of NE type. To withstand high speed operation and to reduce noise and shock, the chain pitch is one-half or less of that of the chains for NE type. To ensure high durability, pins, bushings and rollers are the same as those for strong Z-type.

Use the sprockets exclusive for NSE Bucket Elevator Chains.

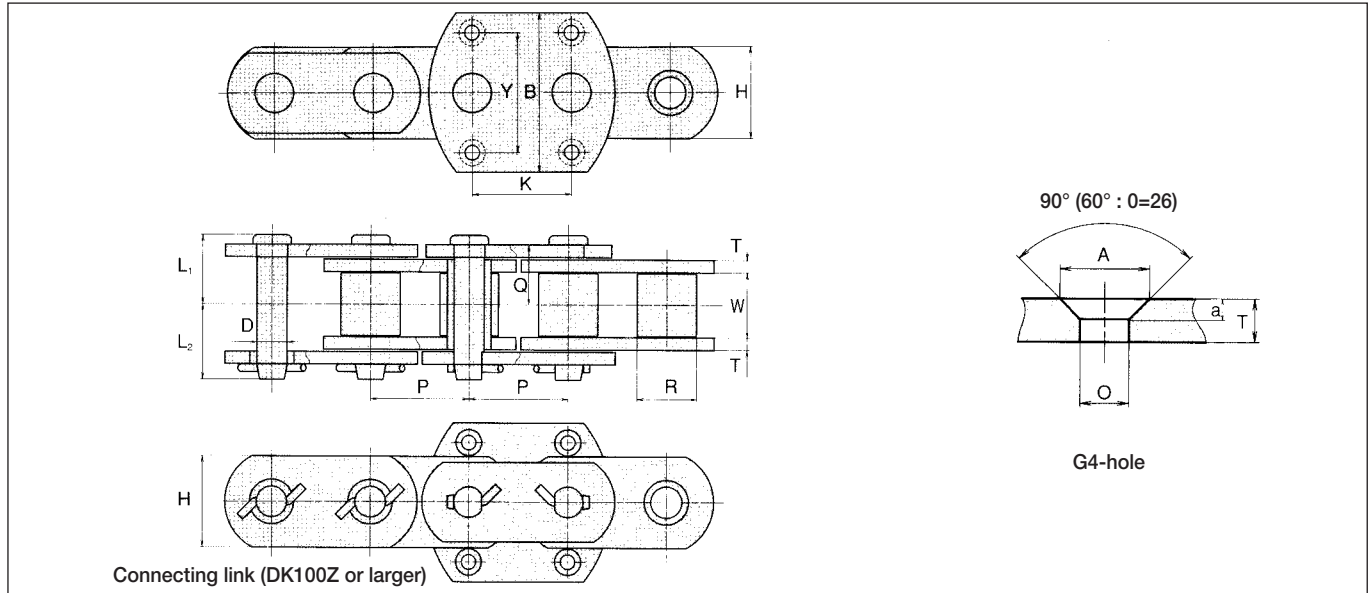

Unit (mm)

Chain No.	Type	Avg. tensile strength		Pitch	Roller link width	Roller dia.	Pin			Plate		Attachment						Flush bolt	Approx. weight (kg/m)		
		Standard	Heavy-duty				P	W	R	D	L <sub>1</sub>	L <sub>2</sub>	T	H	K	Y	B		O	A	a
<b>DK 19076M</b>	Standard	186 (19,000)	—	76.2	36.5	38.1	15.9	40.4	47.1	8	45	75	80	125	14	27	6.5	35	M12	13.1	17.0
<b>DK 28076M</b>		274 (28,000)	—																		
<b>DK 23100M</b>		225 (23,000)	—																		
<b>DK 32100M</b>	313 (32,000)	—	57.6	50.8	22.2	55.7	62.8	65	48.5	24.7	27.3										
<b>DK 35Z100M</b>	Strong Z-type	—	392 (40,000)	100	51.8	44.5	22.2	53.8	60.2	9	57	100	105	150	18	33	7.5	45.5	M16	19.0	21.7
<b>DK 50Z100M</b>		—	588 (60,000)																		
<b>DK 50Z125M</b>		—	—	150	67.4	63.5	31.75	70	78	12	90	150	170	220	22	39	8.5	72	M20	23.0	26.1
<b>DK 75Z125M</b>		—	931 (95,000)																		
<b>DK 75Z150M</b>		—	—	125	67.4	63.5	31.75	70	78	12	90	175	180	230	22	39	8.5	72	M20	34.5	39.7
<b>DK 75Z175M</b>		—	—																		
<b>DK 100Z125M</b>		—	1,225 (125,000)	125	75	70	35	83.2	90.8	16	115	125	130	180	18	33	7.5	72	M16	63.3	68.1
<b>DK 100Z150M</b>		—	—																		
<b>DK 100Z175M</b>		—	—	175	75	70	35	83.2	90.8	16	115	175	180	240	22	39	8.5	72	M20	52.0	59.3
<b>DK 120Z125M</b>		—	—																		
<b>DK 120Z150M</b>	—	1,470 (150,000)	150	82.5	75	38.5	88	95.5	16	115	150	170	230	22	39	8.5	76	M20	68.3	75.1	
<b>DK 120Z175M</b>	—	—																			175
<b>DK 140Z150M</b>	—	1,667 (170,000)	150	85	82	41.75	90.2	99.3	125	125	150	170	230	22	39	8.5	77	M20	81.3	87.8	
<b>DK 140Z175M</b>	—	—																			175
<b>DK 160Z175M</b>	—	1,863 (190,000)	175	92.5	86	44.5	101.2	110.3	19	130	175	180	250	26	42.2	14	87	M24	91.6	99.9	
<b>DK 200Z175M</b>	—	2,225 (230,000)																			175
			150	95	97	50.8	103.5	114	19	150	195						88.5		119.3	134.2	

Note: 1. Pins for DK 23100M and DK 32100M are both-side notched pins. 2. Ask us for the delivery time.

DK Specialty Application Conveyor Chains

# Flat Top Type Chain for Coil Conveyor

Flat Top Type Chain is designed to carry very heavy loads such as steel coils produced by hot rolling or cold rolling in ironworks or steel mills. Based on a standard conveyor chain, the top face of the chain allows stable conveyance of heavy coils.

Since a large load acts on the chain, a heavy-duty construction is adopted. We manufacture 16 kinds of standard Flat Top Type Chains.



The chain features bearings built into the rollers to minimize running resistance, and grease type and maintenance-free non-lubrication type are available.

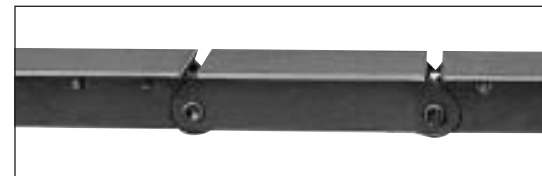
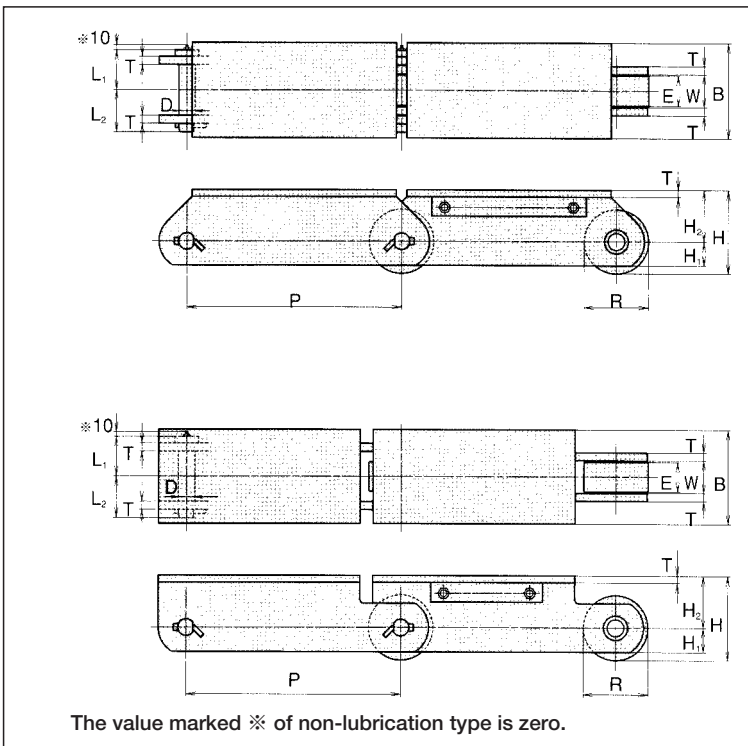

DK Specialty  
Conveyor Chains

Specialized  
Application  
Conveyor Chain

Unit (mm)

Chain No.	Avg. tensile strength		Pitch <b>P</b>	Roller link width <b>W</b>	Roller		Pin			Plate			Top plate		Approx. weight (kg/m)	Bearing rated load Dynamic C / Static C kN (kgf)	
	kN	kgf			<b>R</b>	<b>E</b>	<b>D</b>	<b>L<sub>1</sub></b>	<b>L<sub>2</sub></b>	<b>T</b>	<b>H</b>	<b>H<sub>1</sub></b>	<b>H<sub>2</sub></b>	<b>T<sub>1</sub></b>			<b>B</b>
<b>DK 60300</b>	588	60,000	300	60	125	55	28	64.5	72.5	12	154.5	45	92	12	180	63	158(16,200)
<b>DK 60400</b>			400													58	133(13,600)
<b>DK 60500</b>			500													55	133(13,600)
<b>DK 90300</b>	882	90,000	300	62	135	55	30	74.5	81.5	16	177.5	56	110	16	190	90	204(20,900)
<b>DK 90400</b>			400													83	164(16,800)
<b>DK 90500</b>			500													79	164(16,800)
<b>DK 90300W</b>	882	90,000	300	78	135	71	30	82.5	89.5	16	177.5	56	110	16	210	98	243(24,800)
<b>DK 90400W</b>			400													89	233(23,800)
<b>DK 90500W</b>			500													84	233(23,800)
<b>DK 130300</b>	1,274	130,000	300	76	150	70	38.5	89.5	97.5	19	188	63	113	16	210	119	278(28,400)
<b>DK 130400</b>			400													109	246(25,100)
<b>DK 130500</b>			500													102	246(25,100)
<b>DK 130600</b>			600													97	246(25,100)
<b>DK 160400</b>	1,569	160,000	400	85	175	80	41.5	95.5	102.5	19	221.5	75	134	19	220	139	304(31,000)
<b>DK 160500</b>			500													130	343(35,000)
<b>DK 160600</b>			600													122	343(35,000)

Note: Ask us for the delivery time.

## Long Pan Conveyor Chain

As shown in the photo, this chain is used on a conveyor for carrying bulk, using pans longer than the chain pitch (long pan conveyor). Special attachments are installed to prevent long pans from interfering with the motion of the chain at the points of engagement with the sprockets. Furthermore, to make the entire width of the conveyor smaller, the width of the chain is smaller than a general use chain of the same size, and a smaller pitch is adopted to ensure smooth movement of the conveyor. We manufacture nine kinds of standard Long Pan Conveyor Chains.



Long Pan Conveyor Chain is suitable for carrying a hard abrasive powder of high temperature, and has attachments for installing pans every four or eight links. Pans are pulled by the roller shafts mounted on the attachments to receive pans. Depending on the installation intervals of attachments, L type (every eight links) and S type (every four links) are available.

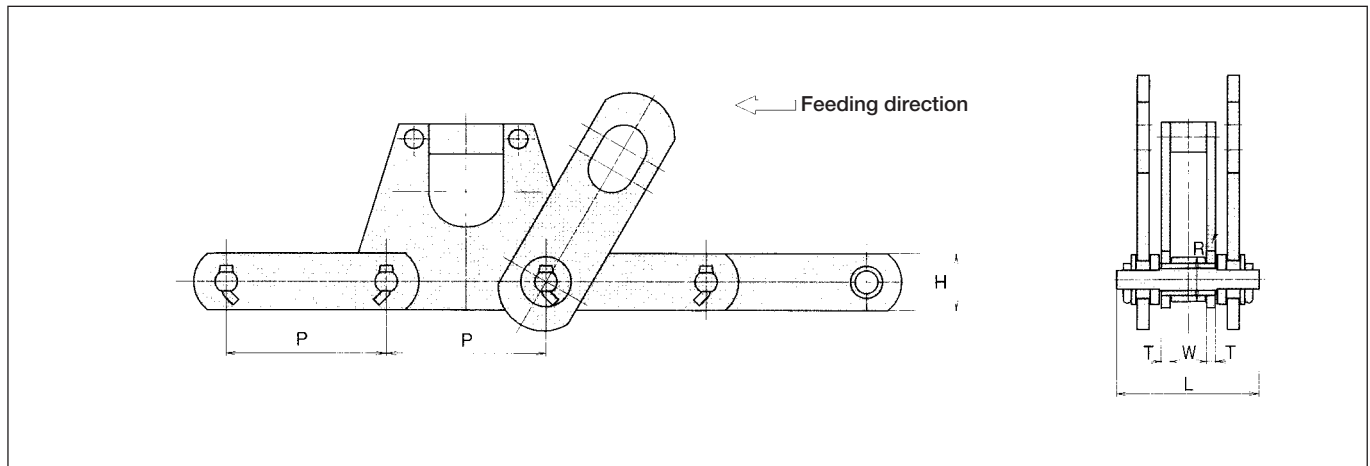

### L Type Long Pan Conveyor Chain

Unit (mm)

Chain No.	Avg. tensile strength		Pitch <b>P</b>	Roller link width <b>W</b>	Roller dia. <b>R</b>	Pin length <b>L</b>	Plate		Approx. weight (kg/8L×2)
	kN	kgf/strand					<b>T</b>	<b>H</b>	
<b>DK 35-160L</b>	323	33,000	160	36.0	44.5	141.7	9	50	47
<b>DK 50-160L</b>	490	50,000	160	46.0	50.8	154.1	9	65	63
<b>DK 75-160L</b>	735	75,000	160	51.4	63.5	187.8	12	80	106
<b>DK 100-160L</b>	980	100,000	160	55.0	70.0	209.5	16	90	155
<b>DK 120-160L</b>	1,176	120,000	160	65.0	75.0	221.5	16	100	185

Note: Ask us for the delivery time.

### S Type Long Pan Conveyor Chain

Unit (mm)

Chain No.	Avg. tensile strength		Pitch <b>P</b>	Roller link width <b>W</b>	Roller dia. <b>R</b>	Pin length <b>L</b>	Plate		Approx. weight (kg/4L×2)
	kN	kgf/strand					<b>T</b>	<b>H</b>	
<b>DK 20-160S</b>	205	21,000	160	30.6	28.58	102.5	6	38	17
<b>DK 35-160S</b>	323	33,000	160	36.0	44.5	141.7	9	50	30
<b>DK 50-160S</b>	490	50,000	160	46.0	50.8	154.1	9	65	38
<b>DK 75-160S</b>	735	75,000	160	51.4	63.5	187.8	12	80	62

Note: Ask us for the delivery time.

DK Specialty Conveyor Chains  
Specialized Application Conveyor Chain

# Block Chain

When a chain having a high tensile strength for the chain width (corresponding to the pin length) is required, a block chain is an excellent choice. A Block Chain is simple and highly rigid since it does not have bushings or rollers. Although the frictional force is large when the chain runs on the floor, the chain has an extended service life because it has no rotating parts. Thus, large loads can be conveyed. Block Chains are suitable for conveyors loading heavy articles with strong impact and conveyors used in severe environments to convey high temperature or abrasion-sensitive and corrosion-sensitive objects.

We manufacture 26 kinds of standard Block Chains in tensile strength ranging from 308kN (=31.5 tons) to 2,721 kN (=277.5 tons). For enhancing reliability of conveyance, block chains with various dogs are designed and manufactured upon request.

## (a) Block Chain

DK Block Chain consists of two outer link plates and one block connected by pins. This unique construction is extremely high in both rigidity and mechanical strength. Also excellent in wear resistance and heat resistance, it is suited for pulling articles as well as for high speed conveyance and conveyance of high-temperature materials. Usually it is combined with various dogs according to the kinds of materials to be conveyed, while it is also possible to load materials directly on the chain or fit the chain with other types of attachments.

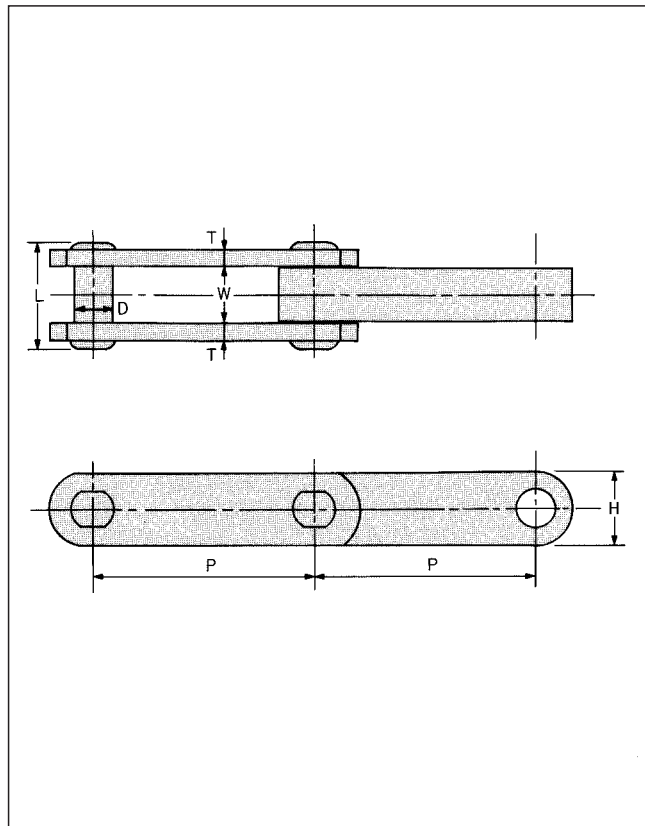

Unit (mm)

Chain No.	Avg. tensile strength		Pitch P	Pin link width W	Pin dia. D	Pin length L	Outer plate		Approx. weight (kg/m)
	kN	kgf					Thickness T	Width H	
<b>DK 32B150</b>	308	31,500	150	24	19.1	48	8	38	7.0
<b>DK 32B200</b>			200						
<b>DK 41B150</b>	397	40,500	150	27	22.0	52	8	45	9.0
<b>DK 41B200</b>			200						
<b>DK 56B200</b>	554	56,500	200	30	25.2	58	9	55	12.3
<b>DK 56B250</b>			250						
<b>DK 63B200</b>	617	63,000	200	34	28.0	62	9	60	13.7
<b>DK 63B250</b>			250						
<b>DK 70B200</b>	720	73,500	200	34	28.0	62	9	65	16.2
<b>DK 70B250</b>			250						
<b>DK 90B200</b>	907	92,500	200	40	31.7	75	12	70	21.0
<b>DK 90B250</b>			250						
<b>DK 115B250</b>	1,117	114,000	250	43	35.0	78	12	75	25.0
<b>DK 115B300</b>			300						
<b>DK 140B250</b>	1,402	143,000	250	48	38.5	84	12	85	32.0
<b>DK 140B300</b>			300						
<b>DK 180B300</b>	1,740	177,500	300	53	41.7	96	16	95	39.0
<b>DK 180B350</b>			350						
<b>DK 210B300</b>	2,152	219,500	300	59	44.5	102	16	110	50.0
<b>DK 210B350</b>			350						
<b>DK 250B300</b>	2,432	248,000	300	69	50.8	120	19	115	58.8
<b>DK 250B350</b>			350						
<b>DK 280B300</b>	2,721	277,500	300	74	56.0	125	19	125	66.0
<b>DK 280B350</b>			350						

Note: Ask us for the delivery time.

DK Specialty  
Conveyor Chains

Specialized  
Application  
Conveyor Chain



## Type of dogs

### 1. Fixed dog

A protrusion is provided on a block or outer plate for conveyance.

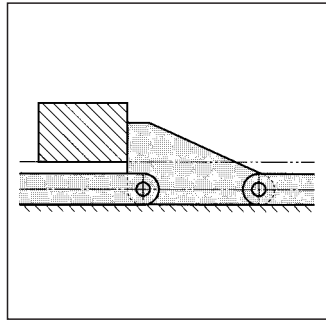

### 3. Duck dog

A duck dog applies pressure on a conveyed article on a guide rail. At the position where the guide rail ends, the dog ducks (drops), leaving the article at that position while passing under it.

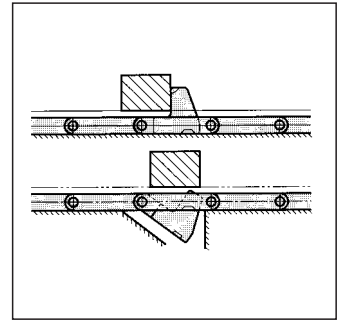

### 2. Tilt dog

A conveyed article in front of the dog is pushed by a dog, such as a fixed dog. When a conveyed article comes from the rear or when the chain travels reversely, the dog is tilted forward, allowing the article to pass. After the article has passed, the dog automatically returns to its original position.

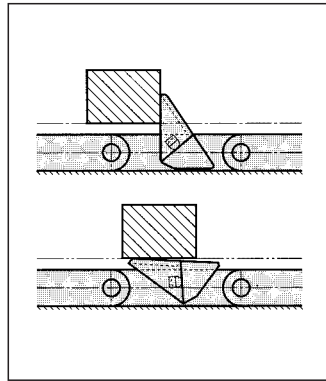

### 4. Tilt duck dog

A tilt duck dog has both the functions of a tilt dog and a duck dog. As it travels on a guide rail, it maintains pressure on a conveyed article. When a conveyed article comes from the rear, the dog tilts to allow it to pass. At the position where the guide rail ends, it ducks to leave the article at that position, while passing under it.

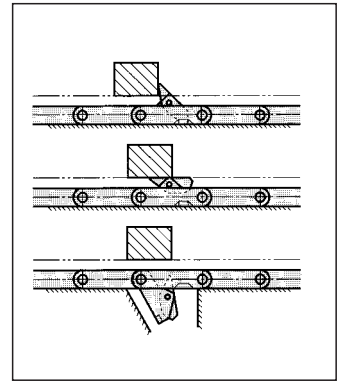

## (b) Special Rivetless Chain

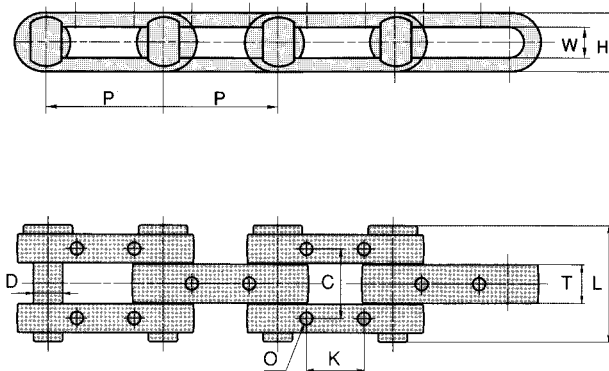

Strengthened type rivetless chain is also available with the dimensions in the following table.

Chain No.	Pitch <b>P</b>	<b>L</b>	<b>D</b>	<b>T</b>	<b>H</b>	<b>W</b>	<b>K</b>	<b>C</b>	<b>O</b>	Avg. tensile strength		Approx. weight (kg/m)
										kN	kgf	
										Unit (mm)		
<b>DK 100-152</b>	152.4	158	30	45	60	32	64	92	13	980	100,000	28.7

Note: Ask us for the delivery time.

## Water Treatment Conveyor Chain

Water Treatment Conveyor Chains are available for the following four applications as standard.

### Chains for Traveling Water Screen

A thermal power plant or nuclear power plant takes in a large quantity of sea water as cooling water. Sea water contains a variety of living organisms, such as jelly fish and algae. A traveling water screen which frame is rotated by a chain removes impurities at the intake port of sea water. Because the chain is used in sea water, resistance to corrosion and brittle fracture are special design considerations. We have been active in the research, development and manufacture of submersible conveyor chains from the early days of their use.

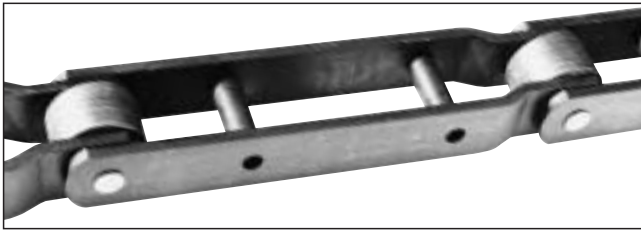

This is a powerful chain designed to be sufficiently resistant to corrosion, wear and impact so that it can serve the purpose of removing massive trash under severe conditions. It is of the offset type, which can allow lengthening and shortening in units of even a single link.

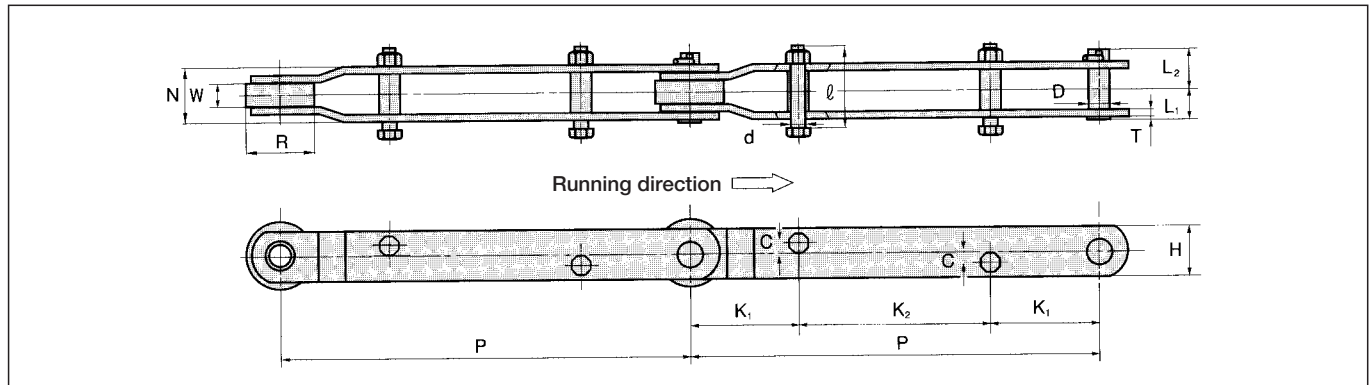
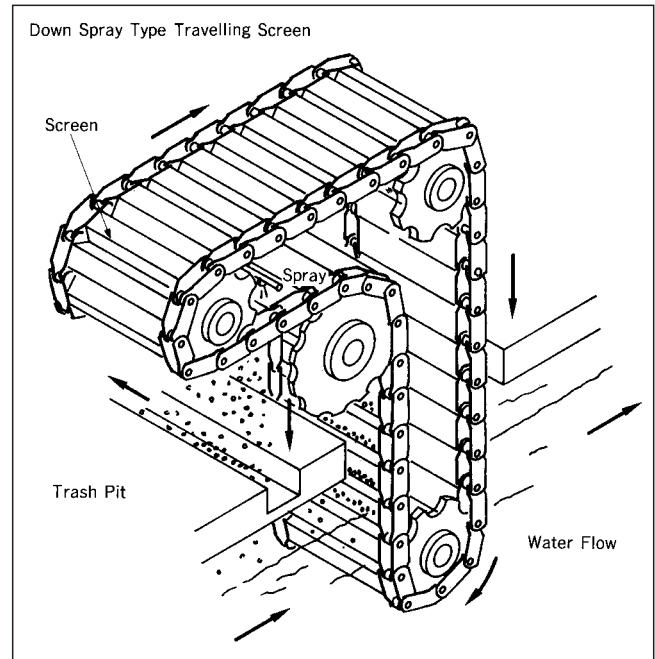

Unit (mm)

Chain No.	Avg. tensile strength		Pitch P	Chain			Roller dia. R	Pin			Plate		Bolt			Weight (kg/リンク)	
	kN	kgf		Inner width W	Outer width N	Dia. D		Length L <sub>1</sub>	Length L <sub>2</sub>	Thickness T	Height H	Dia. d	Length ℓ	Position			
														K <sub>1</sub>	K <sub>2</sub>		C
<b>DK 4520S</b>	333	34,000	450	40.3	80	90	20	43	55	9	65	20	116	130	190	13	7.5
<b>DK 6030S</b>	343	35,000	600	40.3	80	100	30	43	58	9	75	20	116	160	280	13	10.5
<b>DK 6032S</b>	470	48,000	600	55.2	108	100	32	57	72	12	80	20	144	165	270	13	14.5
<b>DK 6034S</b>	588	60,000	600	52.6	122	100	34	64	79	16	80	20	158	165	270	13	18.0
<b>DK 6036S</b>	706	72,000	600	64.6	134	115	36	70.5	85	16	95	24	175	165	270	13	23.0
<b>DK 6040S</b>	784	80,000	600	85.0	166.5	125	40	89.3	101.3	19	100	24	215	185	230	13	33.0

Note: Ask us for the delivery time.



## Rake Chain

Another machine used for the same purpose as the traveling water screen to remove sea water impurities is a bar screen with rotary rakes. The screen is intended to remove impurities more coarse than those removed by the traveling water screen. Impurities caught by a fixed bar screen are removed by rakes and discarded into buckets. A Rake Chain moves the rakes and buckets along the bar screen. As the traveling water screen, resistance to corrosion and brittle fracture are primary design considerations.



Rake Chain used for bar screen consists of the parts made of stainless steel and the link plate coated with a special synthetic resin, and it is highly resistant to corrosion as well as wear.

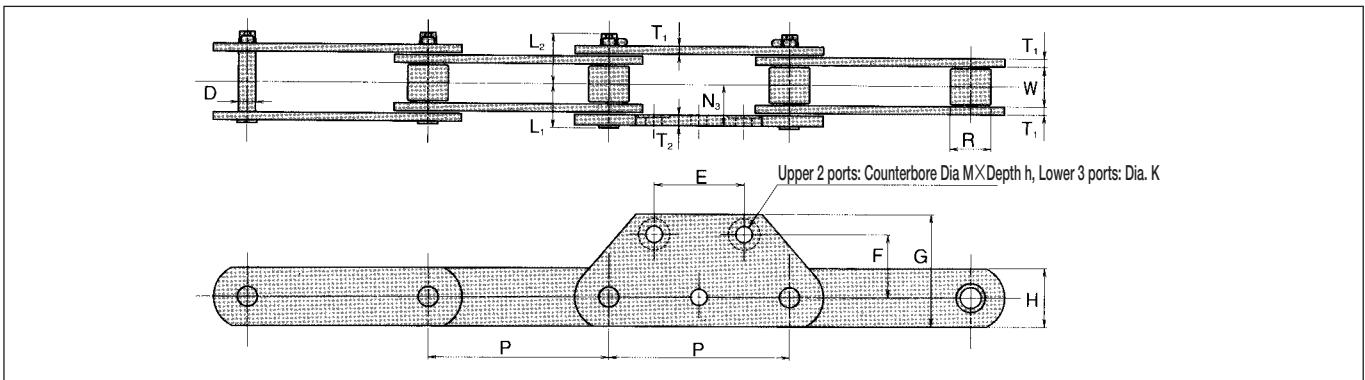
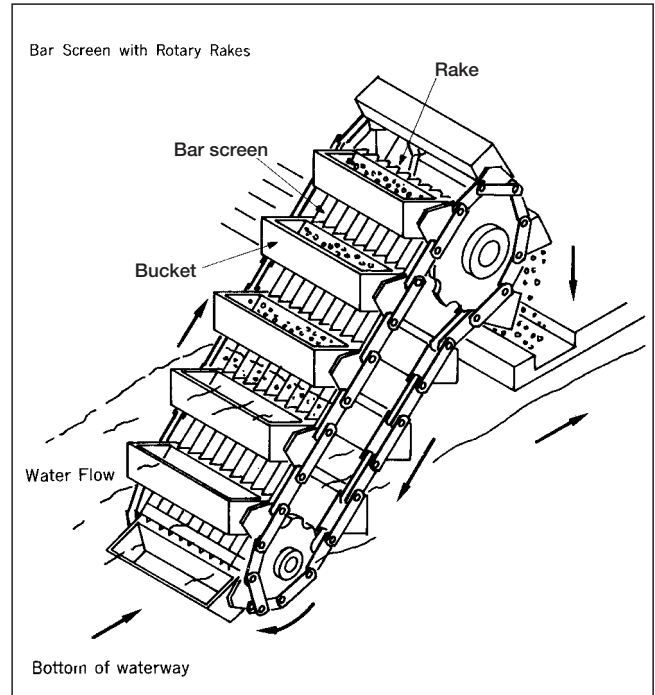

Unit (mm)

Chain No.	Avg. tensile strength		Pitch <b>P</b>	Roller link width <b>W</b>	Roller dia. <b>R</b>	Pin dia. <b>D</b>	Plate width <b>H</b>	Plate thickness <b>T<sub>1</sub></b>	Pin length		Attachment							
	kN	kgf							<b>L<sub>1</sub></b>	<b>L<sub>2</sub></b>	<b>N<sub>3</sub></b>	<b>T<sub>2</sub></b>	<b>E</b>	<b>F</b>	<b>G</b>	<b>K</b>	<b>M</b>	<b>h</b>
<b>DK 20019</b>	299	30,500	200	45	45	19	65	9	48	56	45	12	100	70	125	18	35	3
<b>DK 20023</b>	392	40,000	200	55	55	23	75	9	53	61	50	12	100	100	165	18	35	3
<b>DK 25027</b>	490	50,000	250	55	65	27	80	12	60.5	68.5	57.5	16	180	110	180	22	43	4

Note: Ask us for the delivery time.

# Sewage Treatment Chain (WS or WAS Type Chain)

Chains used for collecting accumulated sediment in setting basins and sedimentation basins or removing the collected sediment in sewage treatment facilities and other water treatment facilities require especially high resistance to corrosion and wear since they are directly exposed to sewage and sludge. A dirt removing chain is moved at a relatively fast speed on an almost vertically installed rail, though the operation frequency is low, so WS Type Roller Chain is used. Conversely, a chain for raking up and/or out dirt is driven at a very slow speed and does not require rollers, so WAS Type Bush Chain is used. Eighteen kinds of WS Type and six kinds of WAS Type Chain are available.



## (a) WS Type Roller Chain

A WS Type Roller Chain is designed to deliver high corrosion resistance and wear resistance for long service in the severe environment of water treatment applications. Since the operating time of this kind of equipment is relatively short, pins and bushings of hardened stainless steel and other parts are made of special alloy steel to ensure smooth bending of the chain, and excellent wear and corrosion resistance.

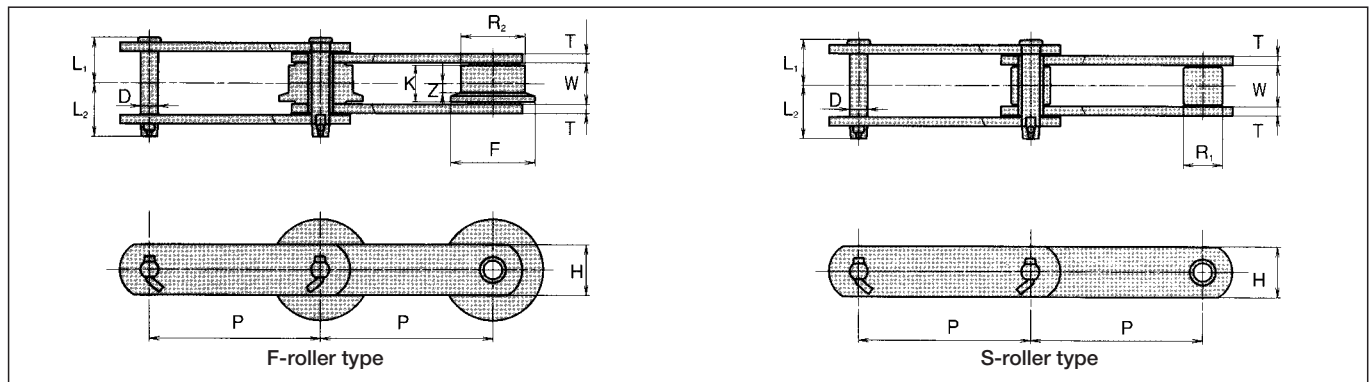
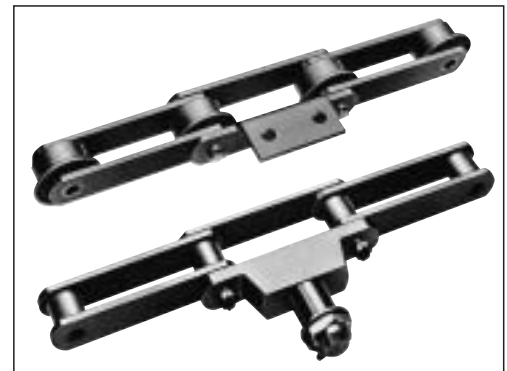

Chain No.	Avg. tensile strength				Pitch <b>P</b>	Roller link width <b>W</b>	S-roller dia. <b>R<sub>1</sub></b>	F-roller				Pin			Plate		Approx. weight (kg/m)
	Standard type		Anti-corrosion type					<b>R<sub>2</sub></b>	<b>F</b>	<b>K</b>	<b>Z</b>	<b>D</b>	<b>L<sub>1</sub></b>	<b>L<sub>2</sub></b>	<b>T</b>	<b>H</b>	
	kN	kgf	kN	kgf													
<b>DK WS 14152F</b>	147	15,000	122	12,500	152.4	27.6	—	44.5	60	17	5.5	11.3	31.6	35.0	6	28.6	6
<b>DK WS 21152F</b>	215	22,000	176	18,000	152.4	30.6	—	50.8	65	20	6.5	14.5	32.6	38.0	6	38	7.8
<b>DK WS 28152F</b>	279	28,500	264	27,000	152.4	36.5	—	65	85	24	8.0	15.9	40.4	47.1	8	45	14.8
<b>DK WS 38152F</b>	382	39,000	323	33,000	152.4	37.5	—	69.9	90	25	8.5	19.1	45.6	52.9	9	50	17.2
<b>DK WS 14152S</b>	147	15,000	122	12,500	152.4	27.6	22.2	—	—	—	—	11.3	31.6	35.0	6	28.6	4
<b>DK WS 21152S</b>	215	22,000	176	18,000	152.4	30.6	28.8	—	—	—	—	14.5	32.6	38.0	6	38	5.7
<b>DK WS 28152S</b>	279	28,500	264	27,000	152.4	36.5	34.9	—	—	—	—	15.9	40.4	47.1	8	45	9.6
<b>DK WS 38152S</b>	382	39,000	323	33,000	152.4	37.5	40.1	—	—	—	—	19.1	45.6	52.9	9	50	12.2
<b>DK WS 51152S</b>	509	52,000	460	47,000	152.4	57.6	44.5	—	—	—	—	22.5	56.7	62.8	9	65	18

Note: Ask us for the delivery time.

## Attachment A2 Type I

Unit (mm)

Chain No.	K	N	S	C	O	X	T <sub>i</sub>	ℓ <sub>1</sub>	d <sub>o</sub>	Additional weight per unit (kg)
<b>DK WS 21152F</b>	60	100	32	55	15	70	8	41.5	M10	0.5
<b>DK WS 28152F</b>	60	100	38	65	19	85	9	51.0	M12	0.6
<b>DK WS 38152F</b>	60	100	45	70	19	90	12	58.5	M16	1.0

Note: Ask us for the delivery time.

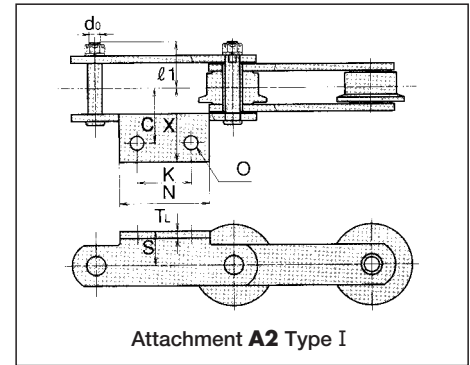

Attachment A2 Type I

## Attachment A2 Type II

Unit (mm)

Chain No.	K	N	S	C	O	X	T	Additional weight per unit (kg)
<b>DK WS 14152F</b>	60	90	28	50	12	79	6	0.26
<b>DK WS 21152F</b>	60	90	32	50	12	72	6	0.22
<b>DK WS 28152F</b>	60	100	38	60	15	82	8	0.35
<b>DK WS 38152F</b>	60	100	45	65	15	101	9	0.53

Note: Ask us for the delivery time.

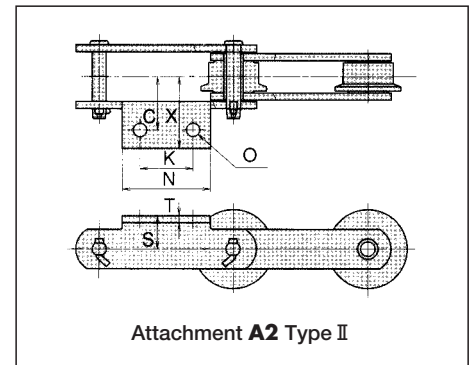

Attachment A2 Type II

## Attachment T

Unit (mm)

Chain No.	ℓ <sub>1</sub>	Q	T <sub>o</sub>	ℓ <sub>2</sub>	T <sub>1</sub>	d	d <sub>1</sub>	d <sub>o</sub>	Additional weight per unit (kg)
<b>DK WS 14152S</b>	38.0	60	30	119.0	16	25	M20	M 8	1.1
<b>DK WS 21152S</b>	41.5	70	40	148.5	16	35	M27	M10	1.9
<b>DK WS 28152S</b>	51.0	78	44	164.5	20	40	M30	M12	2.8
<b>DK WS 38152S</b>	58.5	78	46	173.0	24	45	M36	M16	3.3
<b>DK WS 51152S</b>	68.5	95	50	204.5	24	50	M45	M16	5.3

Note: Ask us for the delivery time.

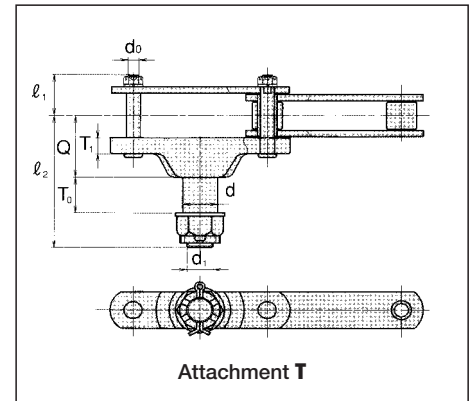

Attachment T

## (b) WAS Type Bush Chain

Heat treated stainless steel provides this chain with excellent performance for corrosion resistance and wear resistance.

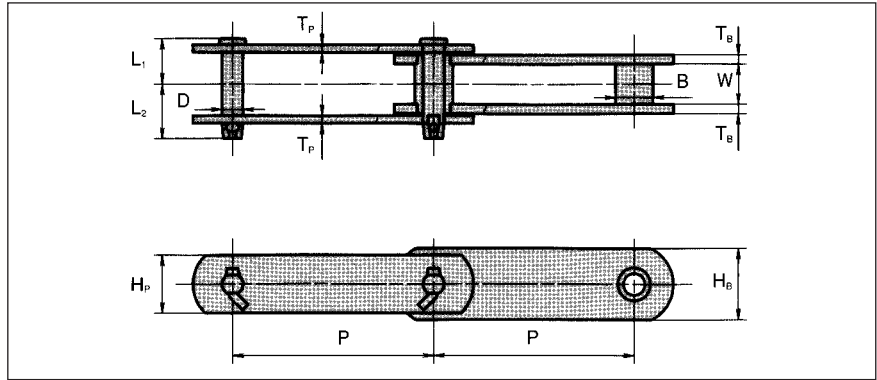
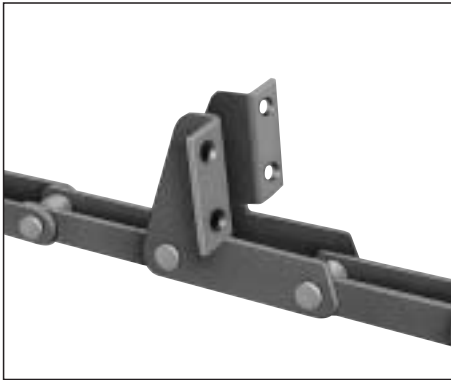

Unit (mm)

Chain No.	Avg. tensile strength		Pitch <b>P</b>	Roller link		Pin			Outer link		Inner link		Approx. weight (kg/m)
	kN	kgf		width <b>W</b>	Bush <b>B</b>	Dia. <b>D</b>	Length <b>L1</b>	<b>L2</b>	Thickness <b>Tp</b>	Height <b>Hp</b>	Thickness <b>Tb</b>	Height <b>Hb</b>	
<b>DK WAS 13078B</b>	132	13,500	78.11	26	23	12.7	27.9	33.3	5	33	5	36	5.2
<b>DK WAS 13103B</b>	132	13,500	103.2	26	23	12.7	27.9	33.3	5	33	5	36	4.6
<b>DK WAS 15152B</b>	147	15,000	152.4	26	24	13.5	29.4	34.3	5	36	6	38	4.8
<b>DK WAS 19152B</b>	186	19,000	152.4	30	26	14.5	32.6	37.5	6	38	6	44	5.9
<b>DK WAS 25152B</b>	245	25,000	152.4	30	29	15.9	34.1	40.9	6	44	7	54	7.9
<b>DK WAS 35152B</b>	343	35,000	152.4	38	35	19.1	40.6	49.0	7	54	7	60	10.9

Note: Ask us for the delivery time.

## Attachment SF4

Unit (mm)

Chain No.	2C	2X	S	S1	S2	J	S3	O	T	Additional weight per unit (kg)
<b>DK WAS 13078B</b>	90	130	110	35	55	38	28	14	5	0.6
<b>DK WAS 13103B</b>	90	130	110	35	55	52	28	14	5	0.7
<b>DK WAS 15152B</b>	100	140	155	65	70	76	35	14	5	1.2
<b>DK WAS 19152B</b>	100	140	155	65	70	76	38	14	6	1.4
<b>DK WAS 25152B</b>	100	140	155	65	70	76	38	14	6	1.4
<b>DK WAS 35152B</b>	110	150	160	65	75	76	40	14	7	1.6

Note: Ask us for the delivery time.

## Attachment LA1

Unit (mm)

Chain No.	d0	C	X	L1	L2	N	O	TA	TL	Additional weight per unit (kg)
<b>DK WAS 13078B</b>	M10	55	77	28.9	42.9	40	19	16	12	0.4
<b>DK WAS 13103B</b>	M10	55	77	28.9	42.9	56	19	16	12	0.6
<b>DK WAS 15152B</b>	M12	55	77	30.4	44.0	68	19	16	12	0.8
<b>DK WAS 19152B</b>	M12	65	90	33.6	51.4	80	24	20	16	1.2
<b>DK WAS 25152B</b>	M14	65	90	35.1	53.9	80	24	20	16	1.4
<b>DK WAS 35152B</b>	M16	75	102	42.6	62.5	80	26	24	19	2.0

Note: Ask us for the delivery time.

## Long pin type

Unit (mm)

Chain No.	d	To	Q	L1	L2	d0	d1	t	Additional weight per unit (kg)
<b>DK WAS 13078B</b>	12	12	24.4	27.9	49.4	M10	22	1.5	0.06
<b>DK WAS 13103B</b>	12	12	24.4	27.9	49.4	M10	22	1.5	0.06
<b>DK WAS 15152B</b>	13	12	25.4	29.4	51.4	M12	26	2.0	0.10
<b>DK WAS 19152B</b>	14	16	28.6	32.6	59.4	M12	26	2.0	0.11
<b>DK WAS 25152B</b>	15.5	16	29.6	34.1	62.4	M14	30	2.5	0.14
<b>DK WAS 35152B</b>	18.5	19	34.6	40.6	72.0	M16	32	2.5	0.20

Note: Ask us for the delivery time.

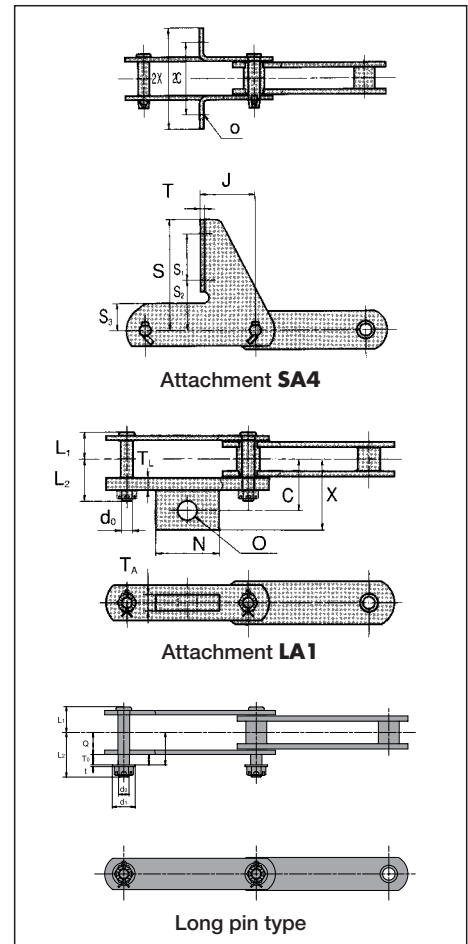

## BF Type Bushing Chain for Water Treatment Drive Unit

This chain is used to connect water treatment equipment to a power source. In the past, JIS/ ANSI type roller chains were used. For enhanced corrosion resistance, all the components are now made of 13Cr stainless steel. Since the chain is operated at a slow speed, a bushing chain without rollers is used. The sprockets are interchangeable with JIS/ ANSI roller chain sprockets. We manufacture seven kinds of BF Type Bushing Chains in a range from DID120 to DID240, including heavy-duty type.

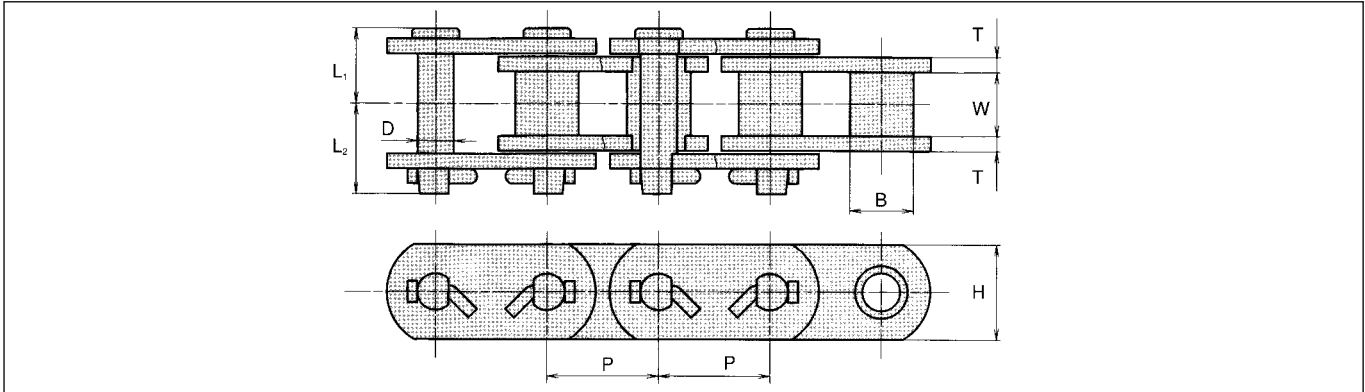

Unit (mm)

Chain No.	Avg. tensile strength		Pitch <b>P</b>	Roller link width <b>W</b>	Bush dia. <b>B</b>	Pin			Plate		Approx. weight (kg/m)
	kN	kgf				Dia. <b>D</b>	Length <b>L<sub>1</sub></b>	Length <b>L<sub>2</sub></b>	Thickness <b>T</b>	Height <b>H</b>	
<b>DID 120BF</b>	107	11,000	38.10	25.4	22.23	12.7	27.3	32.3	5	33	6.8
<b>DID 140BF</b>	137	14,000	44.45	25.4	25.40	14.5	29.8	35.9	6	38	9.5
<b>DID 160BF</b>	181	18,500	50.80	31.7	28.58	15.9	33.7	40.5	6	44	10.9
<b>DID 160BFH</b>	240	24,500	50.80	31.7	28.58	15.9	37.7	44.5	8	45	13.7
<b>DID 200BF</b>	308	31,500	63.50	38.1	39.69	22.2	45.5	51.8	9	54	20.7
<b>DID 200BFH</b>	353	36,000	63.50	38.1	39.69	22.2	47.5	53.8	10	57	21.0
<b>DID 240BF</b>	392	40,000	76.20	47.6	47.62	25.4	53.3	58.6	10	63.5	27.8

Note: Ask us for the delivery time.

### Water treatment flow chart

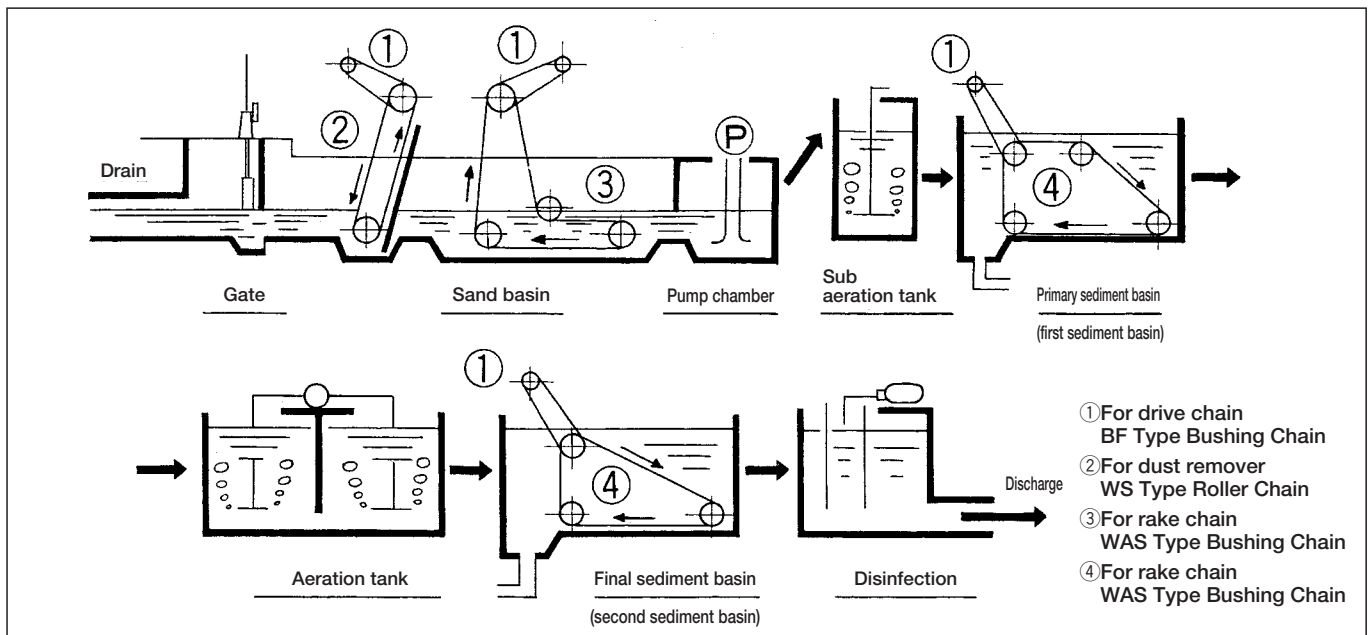



## 3D Bending Conveyor Chain

In general, a chain is bent in transverse direction only. However, a 3D Bending Conveyor Chain can be structurally bent not only horizontally but also vertically. It is used for a conveyor line which moves vertically and changes in direction.

## X Type Chains for Trolleys, and Power & Free Conveyors

X-type Chains are used for trolleys, and power & free conveyors. They are drop-forged rivetless chains featuring high strength, lightweight and easy removal of components. The bottom left photo shows an X-type Chain used as a trolley conveyor with only one rail.

The bottom right photo shows an X-type Chain used for a power & free conveyor. An additional rail is installed to receive the load for higher transfer capability.

A power & free conveyor generally has a so-called stop and go function to connect and disconnect conveyed materials with and from the chain, so that the conveyed materials can be temporarily stopped, mixed and stored.

Three kinds of X-type Chains are available according to required strength.

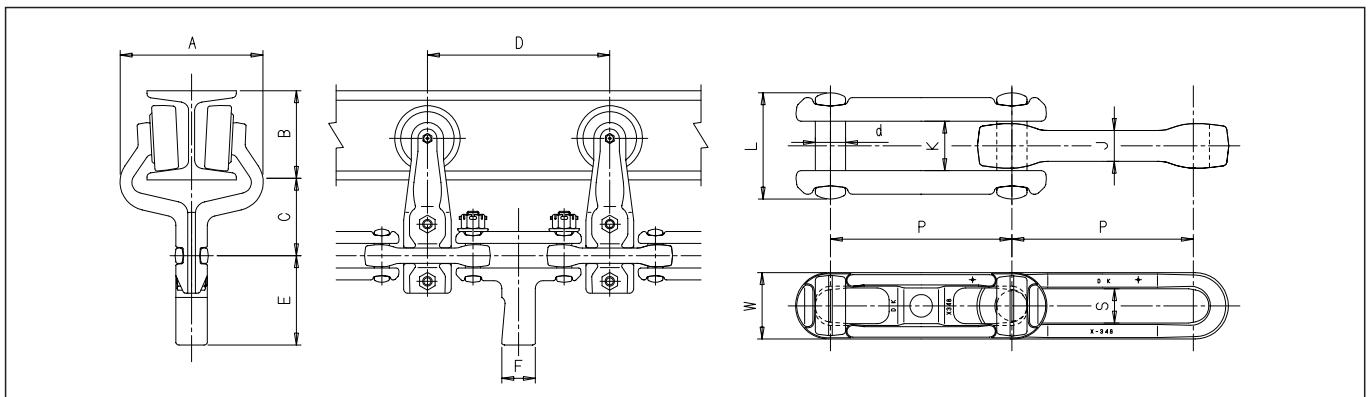
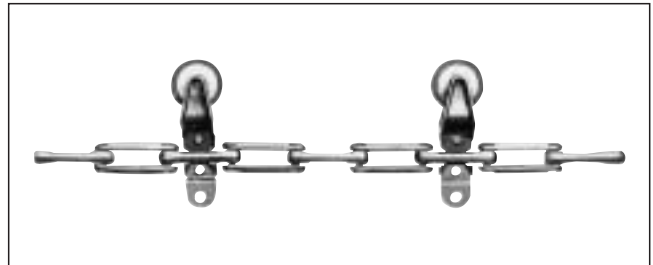

Unit (mm)

Chain No.	Avg. tensile strength		Pitch <b>P</b>	<b>L</b>	<b>W</b>	<b>d</b>	<b>J</b>	<b>K</b>	<b>S</b>	Approx. weight (kg/m)	Power trolley No.	<b>A</b>	<b>B</b>	<b>C</b>	<b>D</b>	Dimension of dog	
	kN	kgf														<b>E</b>	<b>F</b>
<b>DK X348</b>	107	11,000	76.2	45	27	12.7	12.7	20.8	14	3.5	<b>TL-33</b>	118	75	65	152.4	75	28.2
<b>DK X458</b>	215	22,000	101.6	56	35.5	16.2	15.9	27.5	17	5.0	<b>TL-44</b>	140	100	82	203.2	71	31.8

Note: Ask us for the delivery time.

Trolley conveyor system



Power & free conveyor system



## Z-type Chain for Light Load Trolley Conveyors

A Z-type Chain for trolley conveyors is used for service similar to that of X-type Chains described on the previous page, but is suitable for light loads. It is widely used in conveyors supplying parts, and devices for storing and unloading parts on automobile assembling lines.



DK Specialty  
Conveyor Chains

3D Bending  
Conveyor Chain

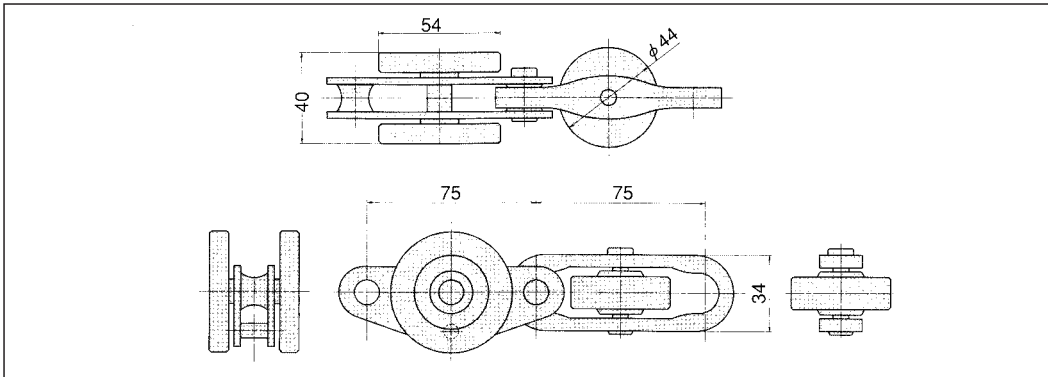

TYPE	Avg. tensile strength		Max. allowable load (kgf)	Max. 1 point suspending load (kgf)	Approx. weight (kg/m)	Vertical radius of curvature (mm)	Horizontal radius of curvature (mm)
	kN	kgf					
<b>Z-75</b>	49.0	5,000	500	25	4.6	600	600

Note: Ask us for the delivery time.

For example, the figure below shows that Z-type Chain running in C-section lightweight steel.

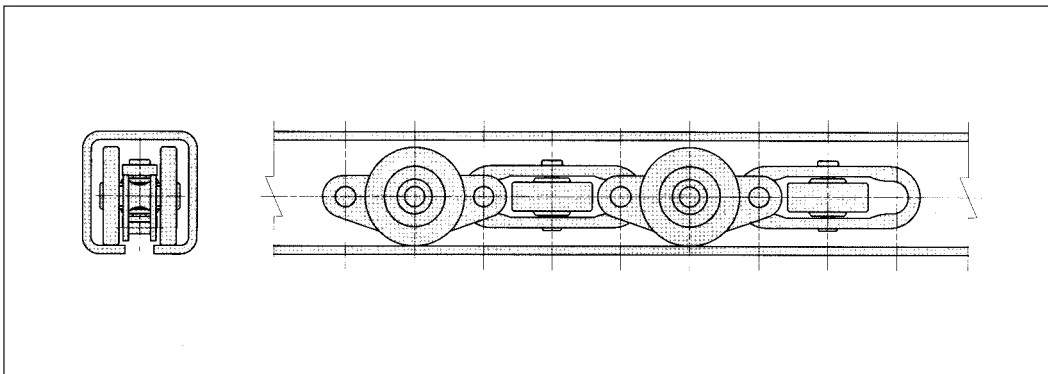



## FH Type Chain for Freeyor

An FH Type Chain is used for the same purpose as an X-type Chain and Z-type Chain. While X-type Chain is designed for heavy loads and Z-type Chain is for light loads, FH Type Chain is used for intermediate loads. While X-type Chain and Z-type Chain can be vertically bent only slightly, FH-type Chain can be bent both vertically and horizontally, which makes it suitable for a conveyor line moving vertically. We manufacture three kinds of FH-type Chains different in pitch.

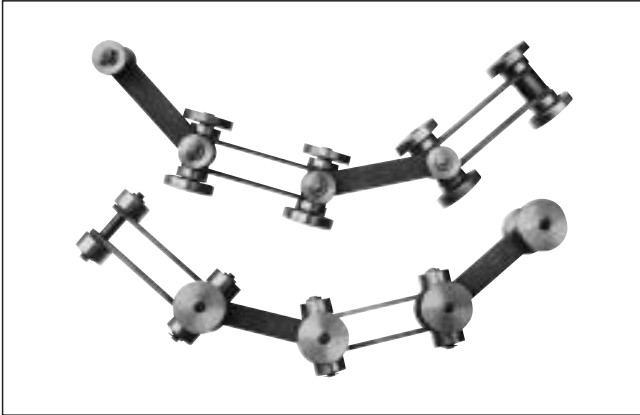

Chain No.	Pitch <b>P</b> (mm)	Max. allowable tension	
		kN	kgf
<b>DK FH-100</b>	100	6.86	700
<b>DK FH-125</b>	125	6.86	700
<b>DK FH-150</b>	150	6.86	700

Note: Ask us for the delivery time.

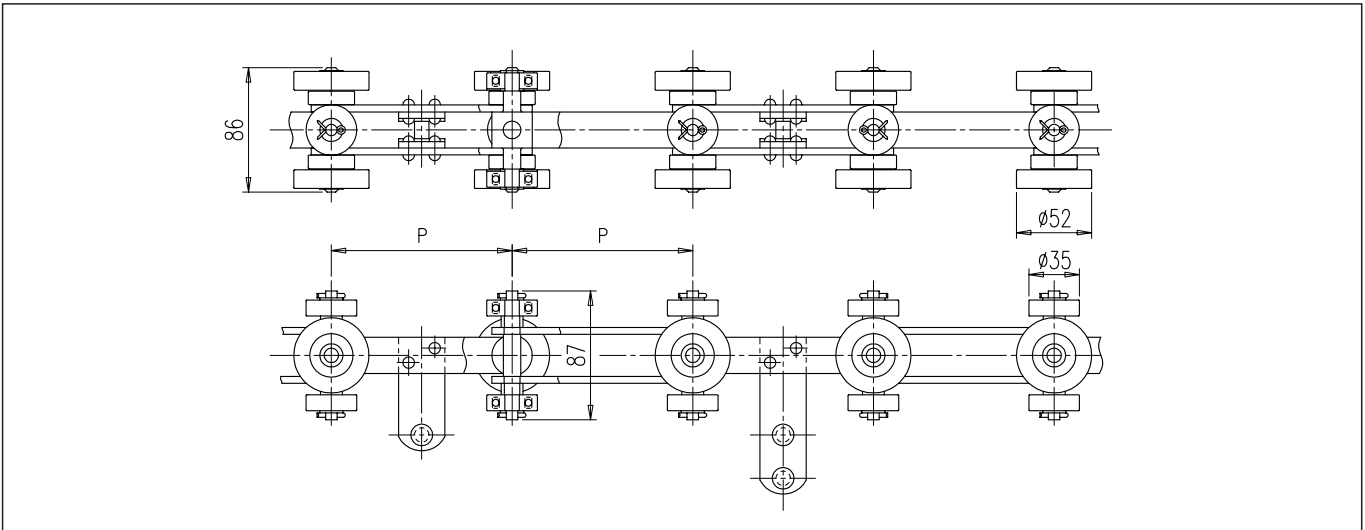

DK Specialty  
Conveyor Chains

3D Bending  
Conveyor Chain

For instance, the figure below shows a condition that FH-type Chain travels in the rail made of two C-section lightweight steel.

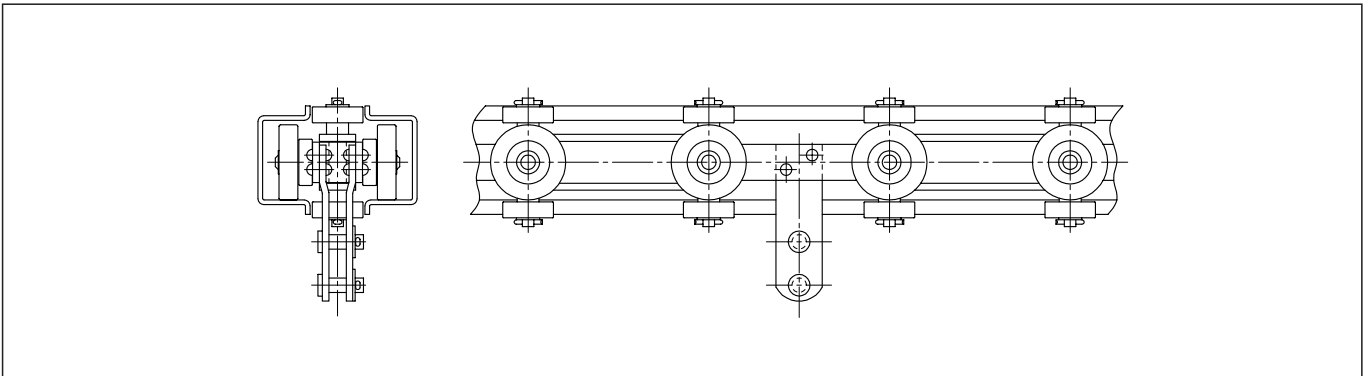

## Towline Low-Selec-Tow Chain

A towline conveyor has a mechanism to convey dollies caught by a chain buried in the floor. Our chain for towline conveyor is called LST chain (Low-selec-tow chain). LST Chain can be bent horizontally and can also move on a slight incline. It is made by forging, and a recess for hooking a dog is formed at the center of each link.

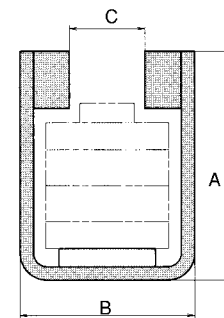
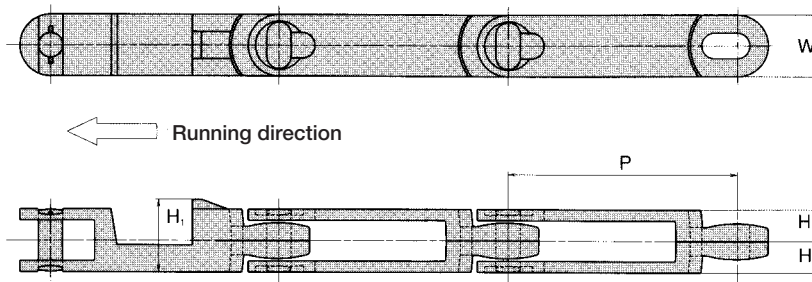

Cross section of track

Unit (mm)

Chain No.	Pitch <b>P</b>	<b>W</b>	<b>H</b>	<b>H<sub>1</sub></b>	Avg. tensile strength		Approx. weight (kg/mm)	Cross section of truck		
					kN	kgf		<b>A</b>	<b>B</b>	<b>C</b>
<b>L.S.T 6"</b>	152.4	40.9	21	48.4	211	21,600	7.5	76.2	58.0	25.0

Note: Ask us for the delivery time.

1. Lower chain link
2. Top chain link
3. Lock pin
4. Pusher dog
5. Chain pin
6. Pusher dog connecting pin

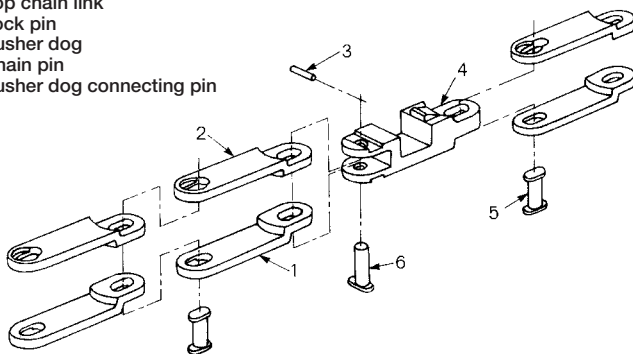

## Booster Chain for Rivetless Chain

A booster chain for rivetless chain is used for driving a rivetless chain by the dogs on the booster chain. Rivetless chain is the general name of X-type Chain for Trolleys and Power & Free Conveyors.

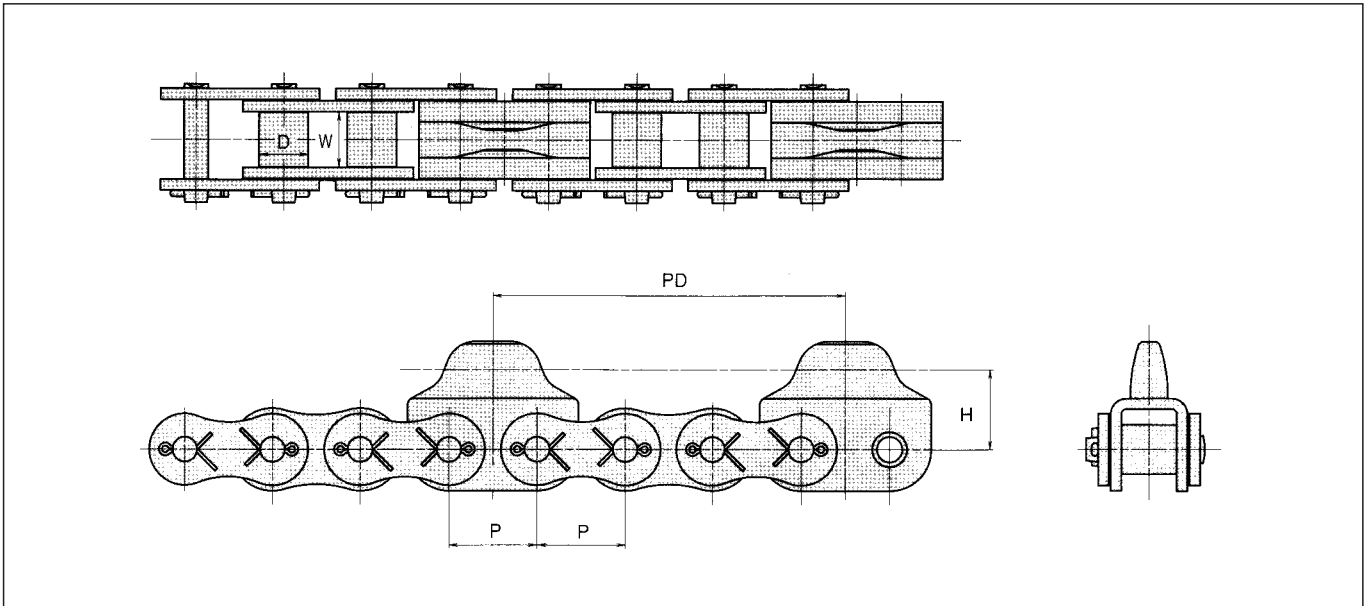
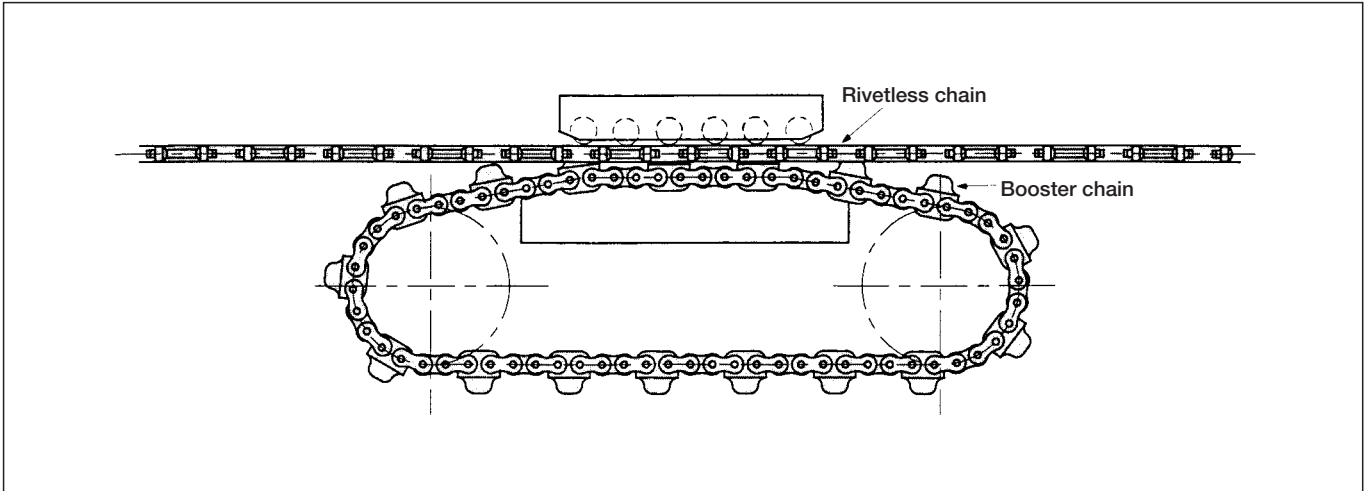

Unit (mm)

Chain No.	Rivetless chain No.	Pitch <b>P</b>	Roller link width <b>W</b>	Roller dia. <b>D</b>	Dog pitch <b>PD</b>	Chain height <b>H</b>
<b>DID 120CP 4P DOG</b>	DK X348	38.1	25.4	22.23	152.4	40
<b>DID 160CP 4P DOG</b>	DK X458	50.8	31.75	28.58	203.2	46

Note: Ask us for the delivery time.

## Draw Bench Chain

Since a chain for drawing a rod in a draw bench requires high strength even though the speed is low, the plates are robust. For example, the following types are designed and supplied to suit for various draw benches.

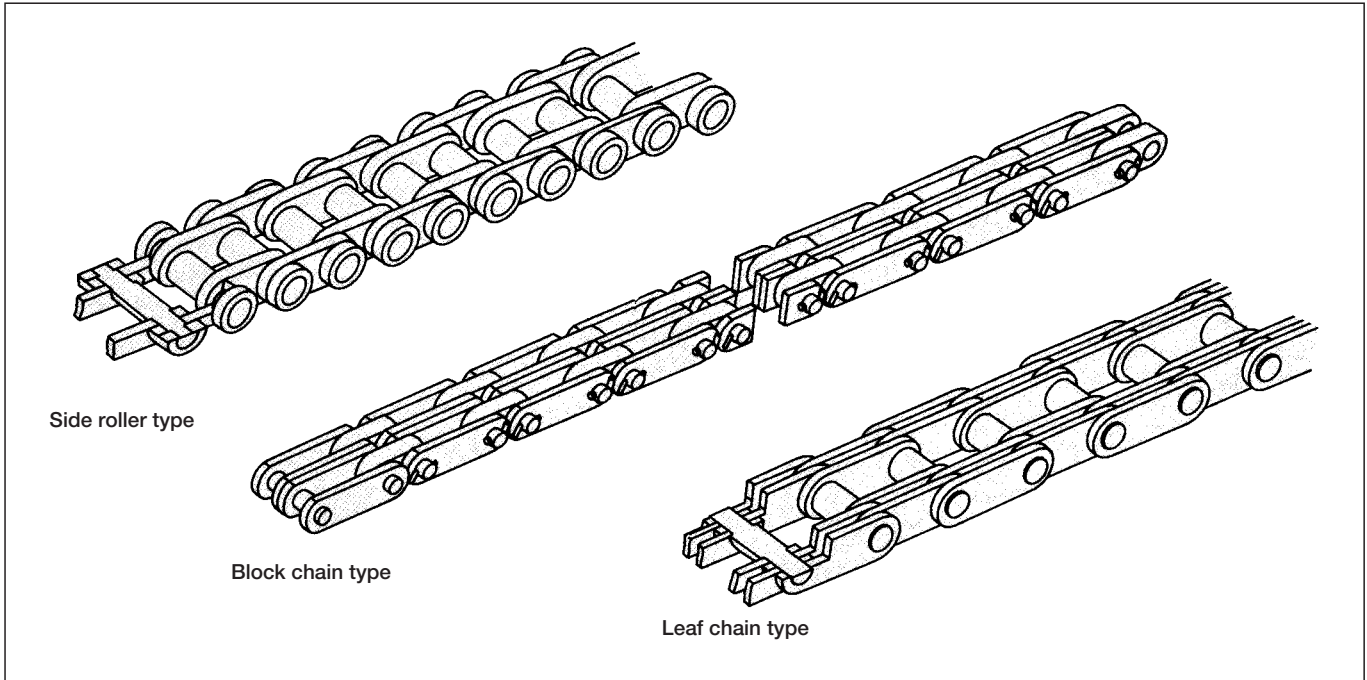

## Chain Bearing Roller

PAT.

Chain Bearing Roller is provided with a special built-in chain instead of a ball bearing or roller bearing. It is suitable for low speed rotation, and is used as conveyor chain rollers which require high durability under severe conditions such as high temperature, large load, dust, scale and corrosive (submerged) atmosphere in steelmaking and other applications where general rolling bearings are not practical.

They are mainly assembled in chain plates, and are also used as rollers of large chains.

### Shape and dimensions (Used independently)

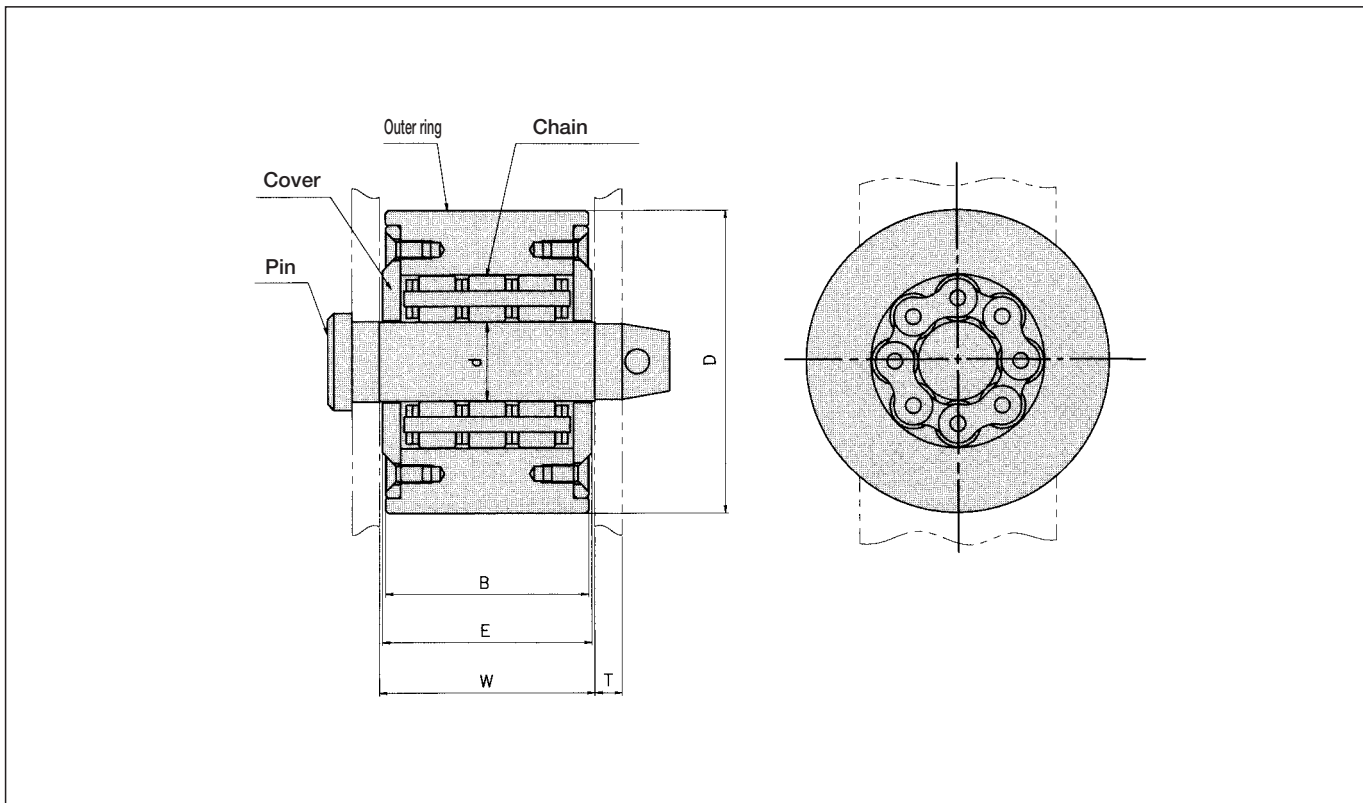

Unit (mm)

Model No.	Dimensions						Max. radial load	
	D	d	B	E	W	T	kN	kgf
<b>CBR 55</b>	55	10	33	35.0	36.5	8	0.98	100
<b>CBR 80</b>	80	26	53	55.6	57.6	9	2.94	300
<b>CBR 100</b>	100	26	66	69.0	71.0	9	4.90	500

Note: 1. Please consult with us for sizes not specified in the above table.  
2. Ask us for the delivery time.

# Other Products Related to Conveyors

Access window (Dr. WINDOW) is a welded access panel for maintenance and checking of the conveyor. There are three types and 17 sizes altogether, and safety nets can be attached to standard and high-neck types.

## Access Window (Dr. WINDOW)

### Overview and Dimenions

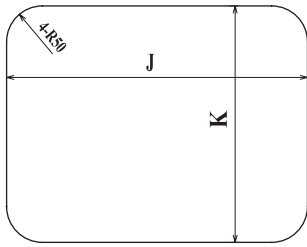

Notch dimensions

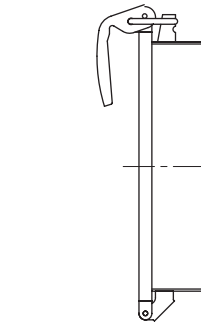
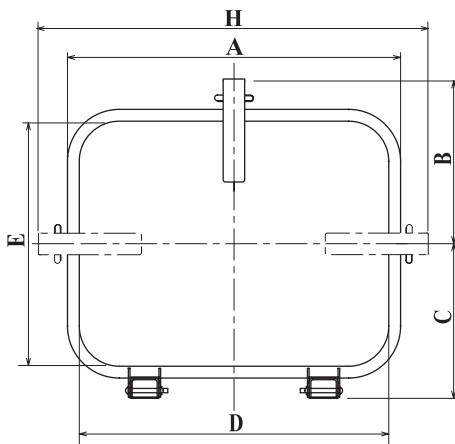

#### High-neck type / IWH

The frame has an extended height compared to the standard type. Optimal for placing at the bending parts of the conveyor line or parts applied with insulation material.

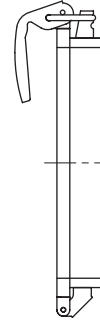

#### Deposit prevention type / IWD

This type is designed to prevent the deposit of materials like powder from the conveyor line.

#### Standard type / IW

The unit is designed to fit the dimensions of the equipment to conduct maintenance and to the service environment. They are also available with metal safety nets for catching tools accidentally dropped.

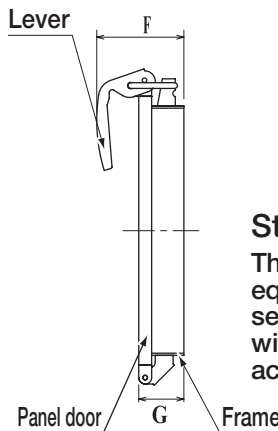

#### Standard type / IW

\* The values for H are the sum of the lever dimensions and A.  
\* The values for weight do not include the safety net weight.

No.	Dimensions (Unit: mm)										Number of lever	Weight (kg)
	A	B	C	D	E	F	G	H	J	K		
IW250	295	112	100	262	112	112	63	—	250	100	1	3
IW300	345	152	140	312	192			—	300	180	1	4
IW420	465	227	215	432	342			—	420	330	1	7
IW480	525	302	290	492	492			—	480	480	2	10
IW800	845	227	215	812	342			—	800	330	2	11
IW1000	1045	277	265	1012	442			—	1000	430	3	16
IW1200	1245	327	315	1212	542			1312	1200	530	5	21

#### High-neck type / IWH

\* The values for H are the sum of the lever dimensions and A.  
\* The values for weight do not include the safety net weight.

No.	Dimensions (Unit: mm)										Number of lever	Weight (kg)
	A	B	C	D	E	F	G	H	J	K		
IWH250	295	112	100	262	112	162	113	—	250	100	1	3
IWH300	345	152	140	312	192			—	300	180	1	5
IWH420	465	227	215	432	342			—	420	330	1	8
IWH480	525	302	290	492	492			—	480	480	2	12
IWH800	845	227	215	812	342			—	800	330	2	14
IWH1000	1045	277	265	1012	442			—	1000	430	3	19
IWH1200	1245	327	315	1212	542			1312	1200	530	5	25

Deposit prevention type / IWD

No.	Dimensions (Unit : mm)									Number of lever (個)	Weight (kg)
	A	B	C	D	E	F	G	J	K		
IWD300	345	152	140	312	192	112	63	300	180	1	4
IWD420	465	227	215	432	342			420	330	1	7
IWD480	525	302	290	492	492			480	480	2	10

Metal safety net (for standard and high-neck types)

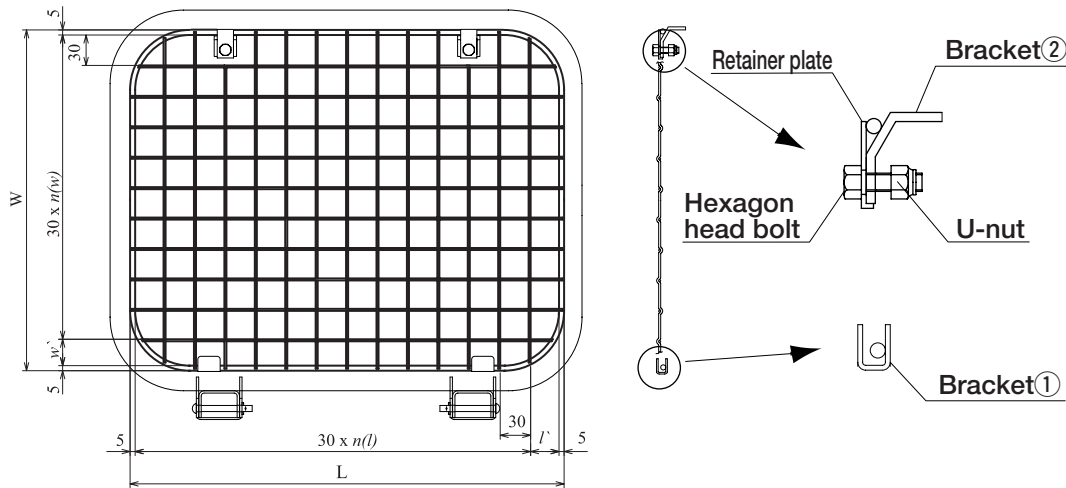

Metal safety net				Fittings		
No.	Dimensions (mm)		Material	Name	Dimension	Material
	L	W				
IW/IWH 300	308	186	SUS304	Bracket ①	—	SUS304
IW/IWH 420	428	336		Bracket ②	—	SS400
IW/IWH 480	488	486		Retainer plate	—	SUS304
IW/IWH 800	804	336		Hexagon head bolt	M6 x 20L	SUS304
IW/IWH 1000	1004	436		U-nut	M6	SUS304
Wire dia. : 2.0, Number of wires : 30 x 30						

Line-up for service environment

Type	Standard (IWH)						High-neck (IWH)				Deposit prevention (IWD)		
	Ambient temperature (V)		Heat resistant (T)		Corrosion resistant (SS)		Ambient temperature (V)		Heat resistant (T)		Ambient temperature (V)	Heat resistant (T)	
Environment	Not attached	Attached (-N)	Not attached	Attached (-N)	Not attached	Attached (-N)	Not attached	Attached (-N)	Not attached	Attached (-N)	Not attached	Not attached	
Metal safety net Notch dimensions (J)	250	○	×	○	×	○	×	○	×	○	×	△	△
	300	○	○	○	○	○	○	○	○	○	○	○	○
	420	○	○	○	○	○	○	○	○	○	○	○	○
	480	○	○	○	○	○	○	○	○	○	○	○	○
	800	○	○	○	○	○	○	○	○	○	○	×	×
	1000	○	○	○	○	△	○	○	○	○	○	×	×
	1200	○	△	○	△	△	△	○	△	○	△	×	×

Note: Consult us for other types of specifications.

Indication

Place an order in the following pattern after confirming the service environment, dimensions, and the attachment of safety net.

Example

High-neck type + notch dimension: 300 mm + ambient temperature + safety net

→ **IWH300V-N** (Nominal indication)

Overview

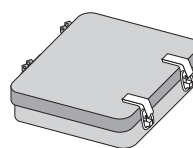

Standard type

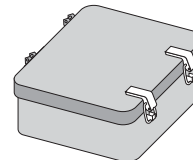

High-neck type

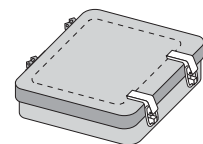

Deposit prevention type



## Photos of Conveyor Systems and Chains in Use

For improving operation efficiency and productivity, DID conveyors and DID physical distribution systems are the ideal equipment.

DID chain conveyors improve factory automation through accurate conveying capacity and excellent durability. Extensive studies of how to efficiently and economically convey a variety of materials has resulted in the manufacture and supply of high performance chain conveyors and physical distribution systems that deliver abundant handling and design advantages. These products are used in almost all industries including iron & steel, cement, chemical and the automobile industry.

DK conveyor chains are the most crucial item of the conveyor system. Materials are selected to suit respective applications and high precision components are solidly assembled by latest equipment. DID chains exhibit excellent toughness and wear resistance in maintaining the accuracy of the conveyor system for an extended period of time.

Introduced here are some of the conveyors and physical distribution systems using DK conveyor chains for improved conveyance.

**Chain conveyors and physical distributions systems**

**Conveyors for direct conveying**

**Conveyors with buckets**

**Conveyors with cases**

**Conveyors for slung articles**

**Conveyors for towing tracks or carriers**

### Conveyors for direct conveying

Coil conveyor



A conveyor for conveying more than ten tons of coils in iron foundries. Depending on the application, the coils are received in many different ways.

Steel panel conveyor



This conveyor is used in a cut plate packing line, and has jigs for receiving plates.

Slab conveyor



In ironworks, in addition to this slab conveyor, various conveyors suitable for respective steel forms such as steel plates and shaped steel are used.

Slat conveyor



This steel slat conveyor is used for assembly, finishing and inspection lines in automobile plants.

Long pan conveyor



A long pan conveyor suitable for conveying high temperature abrasive bulk. This type of conveyor is highly rated by our customers due to the functions for slope conveying and intermediate discharge.

Apron conveyor



An apron conveyor used for conveying scraps, etc. It can also function as a feeder.

Pan conveyor



A pan conveyor used for conveying bulk on a slope, etc.

Hook-on conveyor



A conveyor used for incinerators that operate on fuel converted from waste tires.

## Conveyors with buckets

Bucket elevator (NE type)



An NE type bucket elevator is used for conveying granular material and powder vertically or on a slope. The conveyance capacity ranges from a few tons to more than 1,000 tons per hour.

Bucket elevator (NSE type)

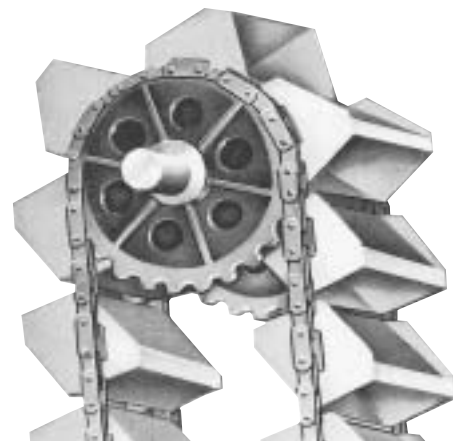

An NSE type bucket elevator allows high speed operation by adopting small pitch chains and sprockets with many teeth. The conveyance capacity can be doubled without changing the cases.



## Conveyor with cases

Continuous flow conveyor



A continuous flow conveyor is used for conveying granular material and powder horizontally and/ or on a slope and/ or vertically.

Dust conveyor

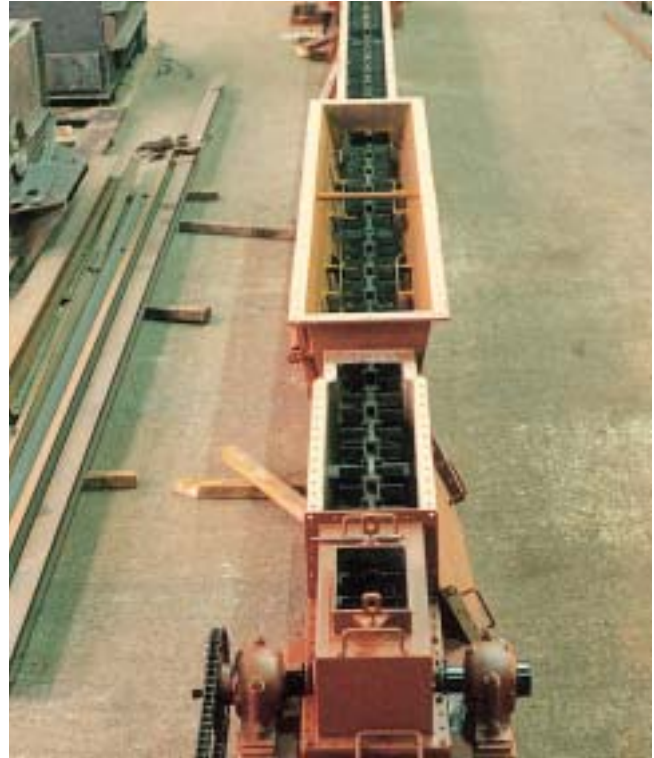

A dust conveyor is used mainly for conveying various kinds of collected dust. It differs from a continuous flow conveyor in the structure of the chain. Wear resistance is taken into account and the cases are designed to be more air-tight.

Scraper conveyor



A scraper conveyor, also called a flight conveyor, conveys articles contained in cases by scrapers installed on the chain. It is also used for conveying dirt in sewage treatment equipment and the ash of incinerated sludge.

## Conveyors for slung articles

Power-and-free conveyor system



A power-and-free conveyor system conveys articles from one production process to another, and also functions to temporarily store the material between processes. Intermittent feeding and variable speed operations are also possible. The system can be used in various production processes.

Trolley conveyor system



A trolley conveyor system is useful for conveying, processing, and storing articles which cannot be efficiently or economically handled by other conveyors.



### Conveyors for towing tracks or carriers

Towline conveyor system for tires



Towline conveyor system for carton transport



Towline conveyor system for stocking



At a furniture manufacturer's warehouse, furniture carton boxes are being carried into the stock area while some are being unloaded for delivery in accordance with the conveyor management program.

## Photos of Specialty Chains

V-pallet type coil conveyor chain

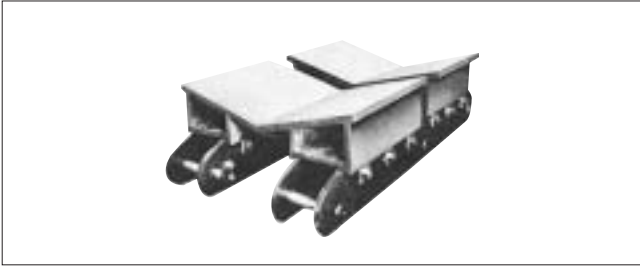

Saddle type coil conveyor chain

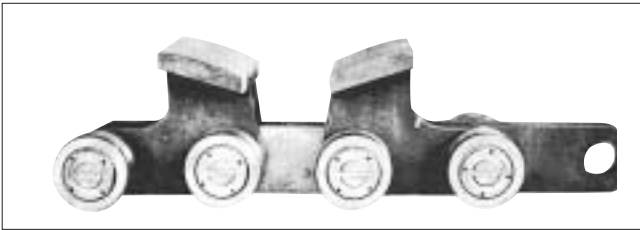

Bolt-mounted flat top coil conveyor chain

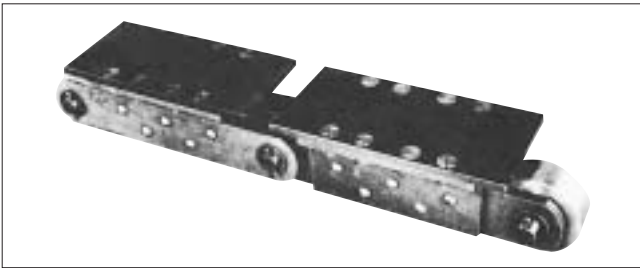

Cart conveyor chain with pusher dog

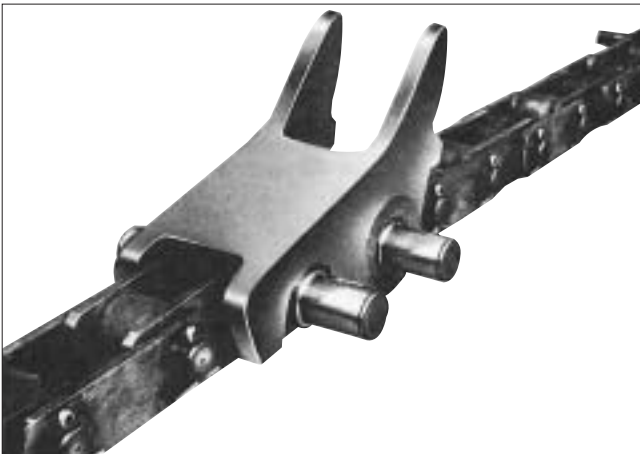

Multiplex block chain for crop conveyor

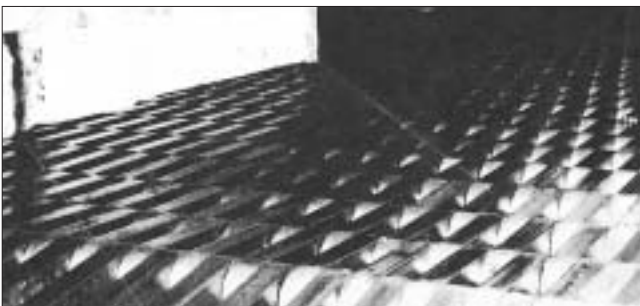

Conveyor chains with various dogs and/or attachments



Photo/ Sprocket

Photo of  
Specialty Chain

## DK Conveyor Chain Sprocket

To ensure that a chain conveyor will fully function, correct matching of conveyor chain and sprockets is necessary. For smooth engagement between the chain and sprockets and accurate feeding of the chain, note the following points for the designing of sprockets.

### Number of teeth

Generally, smoother and more durable operation is ensured with larger number of teeth and sprockets, so ten or more teeth are recommended.

If the conveyance speed is extremely low (10 m/min or less) under a uniform load, the number of teeth can be decreased down to six.

### Tooth form

For accurate and smooth operation of chain conveyors, two types of tooth forms are used depending on the sprocket size: for small sprockets (11 or less teeth) and large sprockets (12 or more teeth).

### Processing of tooth form

The tooth form is usually processed by precision gas cutting. When using chains at high speed or at high stop accuracy, etc., specify machined finishing. If you need wear resistance, induction hardening of teeth is recommended.

### Material

Name	Description	Applicable conveyor
Welded sheet steel	(Hub) Rolled steel for general structural purposes (SS400) (Teeth) Carbon steel for machine structural purposes (S43C or S45C)	Continuous flow conveyor, bucket elevator, coil conveyor, pan conveyor, apron conveyor, dust conveyor (roller chain type) etc.
Cast steel	Cast high tensile carbon steel (SCC3等)	Large bucket elevator, coil conveyor, dust conveyor (block chain type) etc.
	Cast low manganese steel (SCMn3等)	Dust conveyor (block chain type), drag chain conveyor etc.

- Hardening of teeth : All the driving sprockets are induction-hardened. Driven sprockets are treated to suit respective applications.
- Comparison: Use cast iron sprockets for server service conditions like heavy load and high-temperature. Please note that the cost of cast iron sprockets is higher than the other type, and that the delivery takes longer.

### Chemical composition of materials (quoted from JIS)

Material	C	Si	Mn	P	S
Steel					
SS400	—	—	—	0.050 or less	0.050 or less
S43C	0.40~0.46	0.15~0.35	0.60~0.90	0.030 or less	0.035 or less
S45C	0.42~0.48	0.15~0.35	0.60~0.90	0.030 or less	0.035 or less
SCC3	0.30~0.40	0.30~0.60	0.50~0.80	0.04 or less	0.04 or less
SCMn3	0.30~0.40	0.30~0.60	1.00~1.60	0.04 or less	0.04 or less

### Hub dimensions and machining of shaft hole and key slot

Sprocket standard hub dimensions for shaft diameters are listed on P327.

When a plurality of sprockets are used on the same phase, the key slots of the sprockets should be aligned. Specify this when ordering.

The sprockets can be delivered with the shaft holes as prepared. When you finish the shaft holes, refer to the bottoms of teeth.

### Shaft diameter and hub dimensions

For "Shaft Diameter and Hub Dimensions", see P327.

[Welded sheet steel sprocket]



[Cast steel sprockets]



### [Indication]

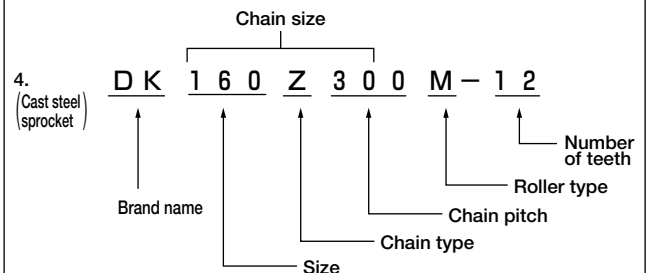
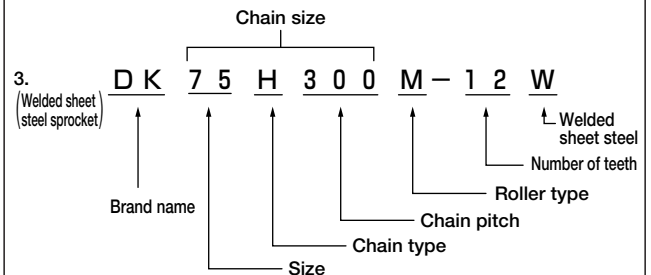
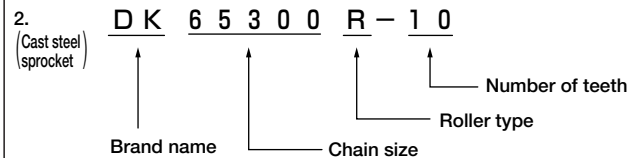
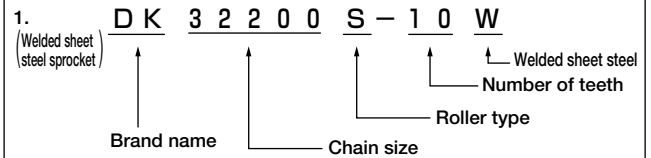



# Tooth Width of Conveyor Chain Sprockets (Standard)

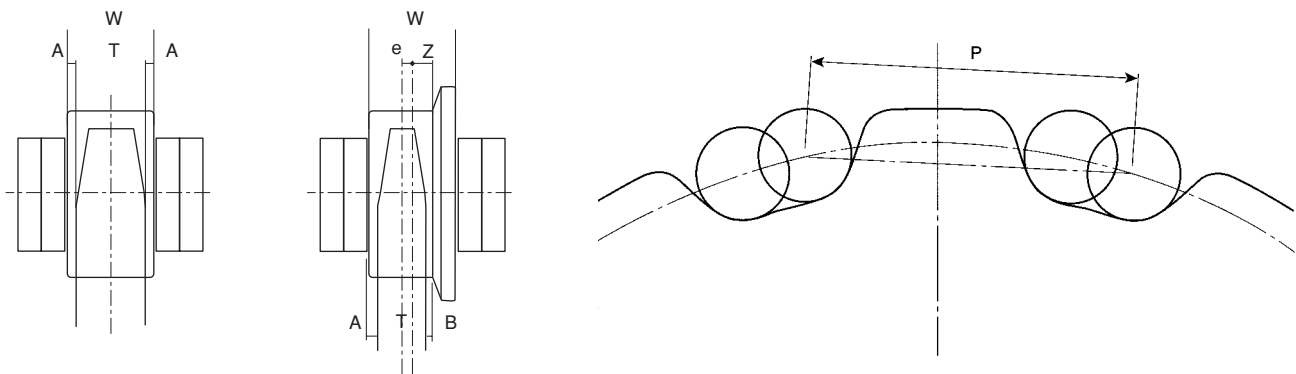

Chain No.	Pitch	W	R-roller		S-roller		M-roller		e	Z	F-roller		
			T	A	T	A	T	A			T	A	B
<b>DK03075</b>	75	15.9							2	3.3			
<b>DK03100</b>	100		12	1.95	12	1.95	—	—			9	1.45	0.8
<b>DK03125</b>	125		( 12 )	( 1.95 )	( 12 )	( 1.95 )	( — )	( — )			( 9 )	( 1.45 )	( 0.8 )
<b>DK03150</b>	150												
<b>DK07075</b>	75	22							2.5	4.5			
<b>DK07100</b>	100		16	3	16	3	—	—			12	2.5	1
<b>DK07125</b>	125		( 17 )	( 2.5 )	( 16 )	( 3 )	( — )	( — )			( 11 )	( 3 )	( 1.5 )
<b>DK07150</b>	150												
<b>DK09100</b>	100	25.6							3	5			
<b>DK09125</b>	125		19	3.3	19	3.3	19	3.3			12	3.8	2
<b>DK09150</b>	150		( 20 )	( 2.8 )	( 20 )	( 2.8 )	( 20 )	( 2.8 )			( 13 )	( 3.3 )	( 1.5 )
<b>DK11100</b>	100	30.6							3.5	6.5			
<b>DK11125</b>	125		22	4.3	22	4.3	22	4.3			16	3.8	2
<b>DK11150</b>	150		( 24 )	( 3.3 )	( 23 )	( 3.8 )	( 23 )	( 3.8 )			( 17 )	( 3.3 )	( 1.5 )
<b>DK11200</b>	200												
<b>DK13150</b>	150	36.5	28	4.25	28	4.25	28	4.25	4	8	19	4.75	2.5
<b>DK13200</b>	200		( 29 )	( 3.75 )	( 28 )	( 4.25 )	( 28 )	( 4.25 )			( 19 )	( 4.75 )	( 2.5 )
<b>DK19200</b>	200	36.5	28	4.25	28	4.25	28	4.25	4	8	19	4.75	2.5
<b>DK19250</b>	250		( 30 )	( 3.25 )	( 29 )	( 3.75 )	( 29 )	( 3.75 )			( 20 )	( 4.25 )	( 2 )
<b>DK19300</b>	300												
<b>DK25200</b>	200	51.8	40	5.9	40	5.9	40	5.9	5	12.5	28	6.9	3.5
<b>DK25250</b>	250		( 43 )	( 4.4 )	( 42 )	( 4.9 )	( 42 )	( 4.9 )			( 30 )	( 5.9 )	( 2.5 )
<b>DK25300</b>	300												
<b>DK32200</b>	200	57.6	45	6.3	45	6.3	45	6.3	6	13.5	32	6.8	3.5
<b>DK32250</b>	250		( 48 )	( 4.8 )	( 47 )	( 5.3 )	( 47 )	( 5.3 )			( 34 )	( 5.8 )	( 2.5 )
<b>DK32300</b>	300												
<b>DK32450</b>	450												
<b>DK50250</b>	250	67.4	55	6.2	55	6.2	55	6.2	7	15	36	8.7	4
<b>DK50300</b>	300		( 56 )	( 5.7 )	( 56 )	( 5.7 )	( 56 )	( 5.7 )			( 36 )	( 8.7 )	( 4 )
<b>DK50450</b>	450												
<b>DK50600</b>	600												
<b>DK65300</b>	300	75	65	5	65	5	65	5	8	16.5	43	8	3
<b>DK65450</b>	450		( 65 )	( 5 )	( 65 )	( 5 )	( 65 )	( 5 )			( 43 )	( 8 )	( 3 )
<b>DK05101</b>	101.6	22.2	16	3.1	16	3.1	—	—	—	—	—	—	—
			( 17 )	( 2.6 )	( 17 )	( 2.6 )	( — )	( — )			( — )	( — )	( — )
<b>DK08066</b>	66.27	27.6	—	—	22	2.8	22	2.8	—	—	—	—	—
			( — )	( — )	( 21 )	( 3.3 )	( 21 )	( 3.3 )			( — )	( — )	( — )
<b>DK08101</b>	101.6	27.6	22	2.8	22	2.8	22	2.8	3	6.5	—	—	—
			( 21 )	( 3.3 )	( 21 )	( 3.3 )	( 21 )	( 3.3 )			( — )	( — )	( — )
<b>DK09101</b>	101.6	27.6	22	2.8	22	2.8	22	2.8	—	—	—	—	—
			( 21 )	( 3.3 )	( 21 )	( 3.3 )	( 21 )	( 3.3 )			( — )	( — )	( — )
<b>DK11152</b>	152.4	30.8	22	4.4	22	4.4	22	4.4	3	7.5	16	4.4	2.5
			( 24 )	( 3.4 )	( 24 )	( 3.4 )	( 24 )	( 3.4 )			( 17 )	( 3.9 )	( 2 )
<b>DK13101</b>	101.6	31	25	3	25	3	25	3	—	—	—	—	—
			( 25 )	( 3 )	( 25 )	( 3 )	( 25 )	( 3 )			( — )	( — )	( — )
<b>DK19152</b>	152.4	36.5	28	4.25	28	4.25	28	4.25	4	8	19	4.75	2.5
			( 30 )	( 3.25 )	( 29 )	( 3.75 )	( 29 )	( 3.75 )			( 21 )	( 3.75 )	( 1.5 )
<b>DK25152</b>	152.4	37.5	28	4.75	28	4.75	28	4.75	4	8.5	19	5.25	3
			( 30 )	( 3.75 )	( 30 )	( 3.75 )	( 30 )	( 3.75 )			( 20 )	( 4.75 )	( 2.5 )

( ) Outer dimension : Welded sheet steel type ( ) Inner dimension : Cast steel type

Photo/ Sprocket

Sprocket

**Tooth Width of Conveyor Chain Sprockets (Strong type)**

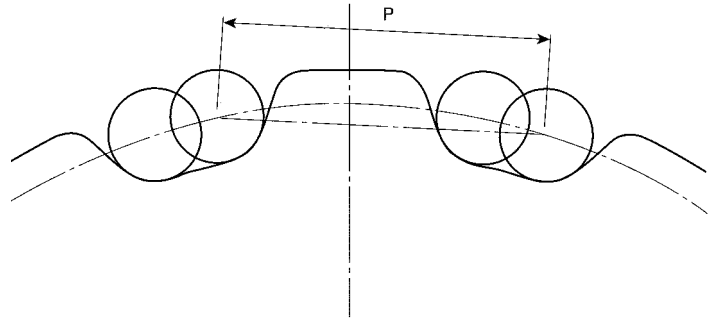
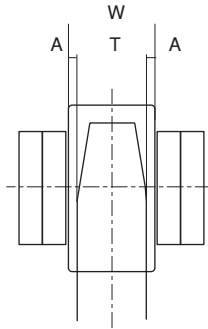

Chain No.		Pitch	W	Driving		Driven	
				T	A	T	A
<b>DK 35H200M</b>	<b>DK 35Z200M</b>	200	51.8	45	3.4	40	5.9
<b>DK 35H250M</b>	<b>DK 35Z250M</b>	250		( 42 )	( 4.9 )	( 39 )	( 6.4 )
<b>DK 50H200M</b>	<b>DK 50Z200M</b>	200					
<b>DK 50H225M</b>	<b>DK 50Z225M</b>	225	57.6	50	3.8	45	6.3
<b>DK 50H250M</b>	<b>DK 50Z250M</b>	250		( 47 )	( 5.3 )	( 43 )	( 7.3 )
<b>DK 50H300M</b>	<b>DK 50Z300M</b>	300					
<b>DK 75H200M</b>	<b>DK 75Z200M</b>	200					
<b>DK 75H250M</b>	<b>DK 75Z250M</b>	250	67.4	55	6.2	50	8.7
<b>DK 75H300M</b>	<b>DK 75Z300M</b>	300		( 56 )	( 5.7 )	( 50 )	( 8.7 )
<b>DK 75H350M</b>	<b>DK 75Z350M</b>	350					
<b>DK100H250M</b>	<b>DK100Z250M</b>	250	75	—	—	55	10
<b>DK100H300M</b>	<b>DK100Z300M</b>	300		( 65 )	( 5 )	( 57 )	( 9 )
<b>DK100H350M</b>	<b>DK100Z350M</b>	350					
<b>DK120H250M</b>	<b>DK120Z250M</b>	250					
<b>DK120H300M</b>	<b>DK120Z300M</b>	300	82.5	—	—	—	—
<b>DK120H350M</b>	<b>DK120Z350M</b>	350		( 72 )	( 5.25 )	( 63 )	( 9.75 )
<b>DK120H400M</b>	<b>DK120Z400M</b>	400					
<b>DK140H300M</b>	<b>DK140Z300M</b>	300	85	—	—	—	—
<b>DK140H350M</b>	<b>DK140Z350M</b>	350		( 74 )	( 5.5 )	( 64 )	( 10.5 )
<b>DK140H400M</b>	<b>DK140Z400M</b>	400					
<b>DK160H300M</b>	<b>DK160Z300M</b>	300	92.5	—	—	—	—
<b>DK160H350M</b>	<b>DK160Z350M</b>	350		( 82 )	( 5.25 )	( 70 )	( 11.25 )
<b>DK160H400M</b>	<b>DK160Z400M</b>	400					
<b>DK200H350M</b>	<b>DK200Z350M</b>	350	95	—	—	—	—
<b>DK200H400M</b>	<b>DK200Z400M</b>	400		( 84 )	( 5.5 )	( 72 )	( 11.5 )
<b>DK200H450M</b>	<b>DK200Z450M</b>	450					
<b>DK250H350M</b>	<b>DK250Z350M</b>	350	100	—	—	—	—
<b>DK250H400M</b>	<b>DK250Z400M</b>	400		( 90 )	( 5 )	( 76 )	( 12 )
<b>DK250H500M</b>	<b>DK250Z500M</b>	500					

( ) Outer dimension : Welded sheet steel type  
 ( ) Inner dimension : Cast steel type

# Tooth Width of Conveyor Chain Sprockets (High-speed BE-type)

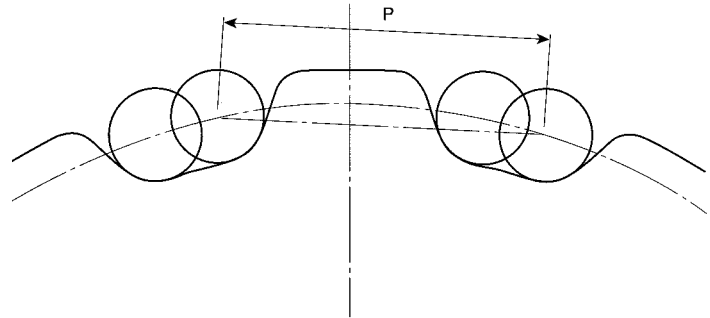
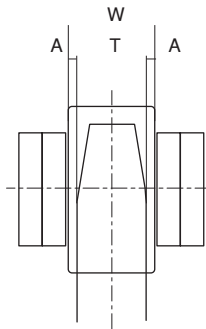

Chain No.	Pitch	W	Driving		Driven	
			T	A	T	A
<b>DK19076M</b>	76.2	36.5	28	4.25	28	4.25
			( 29 )	( 3.75 )	( 29 )	( 3.75 )
<b>DK28076M</b>	76.2	36.5	28	4.25	28	4.25
			( 29 )	( 3.75 )	( 29 )	( 3.75 )
<b>DK23100M</b>	100	51.8	40	5.9	40	5.9
			( 42 )	( 4.9 )	( 39 )	( 6.4 )
<b>DK32100M</b>	100	57.6	40	8.8	40	8.8
			( 42 )	( 7.8 )	( 39 )	( 9.3 )
<b>DK35Z100M</b>	100	51.8	40	5.9	40	5.9
			( 42 )	( 4.9 )	( 39 )	( 6.4 )
<b>DK50Z100M</b>	100	57.6	45	6.3	45	6.3
<b>DK50Z125M</b>	125		( 47 )	( 5.3 )	( 43 )	( 7.3 )
<b>DK50Z150M</b>	150					
<b>DK75Z100M</b>	100	67.4	55	6.2	50	8.7
<b>DK75Z125M</b>	125		( 56 )	( 5.7 )	( 50 )	( 8.7 )
<b>DK75Z150M</b>	150					
<b>DK75Z175M</b>	175					
<b>DK100Z125M</b>	125	75	—	—	55	10
<b>DK100Z150M</b>	150		( 65 )	( 5 )	( 57 )	( 9 )
<b>DK100Z175M</b>	175					
<b>DK120Z125M</b>	125	82.5	—	—	63	9.75
<b>DK120Z150M</b>	150		( 72 )	( 5.25 )	( 63 )	( 9.75 )
<b>DK120Z175M</b>	175					
<b>DK140Z150M</b>	150	85	—	—	64	10.5
<b>DK140Z175M</b>	175		( 74 )	( 5.5 )	( 64 )	( 10.5 )
<b>DK160Z175M</b>	175	92.5	—	—	70	11.25
			( 82 )	( 5.25 )	( 70 )	( 11.25 )
<b>DK200Z175M</b>	175	95	—	—	—	—
			( 84 )	( 5.5 )	( 72 )	( 11.5 )

( ) Outer dimension : Welded sheet steel type  
 ( ) Inner dimension : Cast steel type

**Outer Diameter of DK Conveyor Chain Sprockets: Do (Welded sheet steel type) [1]**

Pitch P	Chain No.	Roller dia. d	Outer dia. (Do)									
			6	7	8	9	10	11	12	13	14	15
66.27	<b>DK08066 S.M</b>	22.2	155	175	195	216	237	257	278	299	320	341
75	<b>DK03075 R.F</b>	30	180	203	226	249	273	296	320	343	367	391
	<b>S</b>	15.9	166	189	212	235	259	282	306	329	353	377
	<b>DK07075 R.F</b>	40	182	205	228	251	275	298	322	345	369	393
	<b>S</b>	22.2	172	195	218	241	265	288	312	335	359	383
100	<b>DK03100 R.F</b>	30	230	260	291	322	354	385	416	448	479	511
	<b>S</b>	15.9	216	246	277	308	340	371	402	434	465	497
	<b>DK07100 R.F</b>	40	232	262	293	324	356	387	418	450	481	513
	<b>S</b>	22.2	222	253	284	315	346	377	401	440	472	503
	<b>DK09100 R.F</b>	45	236	266	297	328	360	391	422	454	485	517
	<b>S.M</b>	26.5	227	257	288	319	350	382	413	444	476	507
	<b>DK11100 R.F</b>	50	240	270	301	332	364	395	426	458	489	521
	<b>S.M</b>	28.8	229	259	290	321	352	384	415	446	478	510
101.6	<b>DK05101 R</b>	38.1	233	264	296	327	359	391	423	455	487	519
	<b>S</b>	20.1	223	254	286	317	349	381	413	445	477	509
	<b>DK08101 R.F</b>	44.5	239	270	301	333	364	396	428	460	492	524
	<b>S.M</b>	22.2	225	256	288	319	351	383	415	447	479	511
	<b>DK09101 R</b>	38.1	233	264	296	327	359	391	423	455	487	519
	<b>S.M</b>	26.5	230	261	292	324	355	387	419	451	483	515
	<b>DK13101 R</b>	44.5	239	270	301	333	364	396	428	460	492	524
	<b>S.M</b>	31.8	235	266	297	329	361	392	424	456	488	521
125	<b>DK03125 R.F</b>	30	280	318	357	395	435	474	513	552	592	631
	<b>S</b>	15.9	266	304	343	381	420	460	499	538	578	617
	<b>DK07125 R.F</b>	40	282	320	359	397	437	476	515	554	594	633
	<b>S</b>	22.2	272	310	349	388	427	466	505	545	584	623
	<b>DK09125 R.F</b>	45	286	324	363	401	441	480	519	558	598	637
	<b>S.M</b>	26.5	276	315	353	392	431	470	510	549	588	628
	<b>DK11125 R.F</b>	50	290	328	367	405	445	484	523	562	602	641
	<b>S.M</b>	28.8	279	317	355	394	433	473	512	551	591	630
150	<b>DK03150 R.F</b>	30	330	376	422	469	515	562	610	657	704	751
	<b>S</b>	15.9	316	362	408	454	501	548	595	643	690	737
	<b>DK07150 R.F</b>	40	332	378	424	471	517	564	612	659	706	753
	<b>S</b>	22.2	322	368	414	461	508	555	602	649	696	744
	<b>DK09150 R.F</b>	45	336	382	428	475	521	568	616	663	710	757
	<b>S.M</b>	26.5	327	372	418	465	512	559	606	653	701	748
	<b>DK11150 R.F</b>	50	340	386	432	479	525	572	620	667	714	761
	<b>S.M</b>	28.8	329	375	421	467	514	561	608	656	703	750
152.4	<b>DK13150 R.F</b>	60	348	394	440	487	533	580	628	675	722	769
	<b>S.M</b>	31.8	332	378	424	470	517	564	612	659	706	753
	<b>DK11152 R.F</b>	50.8	345	392	439	486	534	582	630	677	726	774
	<b>S.M</b>	25.8	331	377	424	471	519	567	615	663	711	759
	<b>DK19152 R.F</b>	57.2	351	397	444	491	539	587	635	683	731	779
	<b>S.M</b>	34.9	340	386	433	480	528	576	624	672	720	768
200	<b>DK25152 R.F</b>	69.9	361	407	454	502	549	597	645	693	741	789
	<b>S.M</b>	40.1	345	391	438	486	533	581	629	677	725	773
	<b>DK11200 R.F</b>	50	440	501	562	625	687	750	813	876	939	1,002
	<b>S.M</b>	28.8	429	490	551	614	676	739	802	865	928	991
	<b>DK13200 R.F</b>	60	448	509	571	633	695	758	821	884	947	1,010
	<b>S.M</b>	31.8	432	493	555	617	679	742	805	868	931	994
200	<b>DK19200 R.F</b>	65	452	513	575	637	699	762	825	888	951	1,014
	<b>S.M</b>	34.9	435	496	558	620	682	745	808	871	934	997

Photo/ Sprocket

Sprocket

## Outer Diameter of DK Conveyor Chain Sprockets: Do (Welded sheet steel type) [2]

Pitch P	Chain No.	Roller dia. d	Outer dia. (Do)									
			6	7	8	9	10	11	12	13	14	15
200	<b>DK25200 R.F</b>	80	464	525	587	649	711	774	837	900	963	1,026
	<b>S.M</b>	40.1	440	501	563	625	687	750	813	876	939	1,002
	<b>DK32200 R.F</b>	100	480	541	603	665	727	790	853	916	979	1,042
	<b>S.M</b>	44.5	445	505	567	629	692	754	817	880	943	1,006
	<b>DK35Z200M</b> <b>DK35H200M</b>	44.5					686	747				
	<b>DK50Z200M</b> <b>DK50H200M</b>	50.8					690	754				
225	<b>DK75Z200M</b> <b>DK75H200M</b>	63.5					701	764				
	<b>DK50Z225M</b> <b>DK50H225M</b>	50.8					771	841				
250	<b>DK19250 R.F</b>	65	552	628	705	783	861	939	1,018	1,097	1,175	1,254
	<b>S.M</b>	34.9	535	611	688	766	844	922	1,001	1,080	1,158	1,237
	<b>DK25250 R.F</b>	80	564	640	717	795	873	951	1,030	1,109	1,187	1,266
	<b>S.M</b>	40.1	540	616	693	771	849	928	1,006	1,085	1,164	1,243
	<b>DK32250 R.F</b>	100	580	656	733	811	889	967	1,046	1,125	1,203	1,282
	<b>S.M</b>	44.5	545	621	698	775	854	932	1,010	1,089	1,168	1,247
	<b>DK50250 R.F</b>	125	600	676	753	831	909	987	1,066	1,145	1,223	1,302
	<b>S.M</b>	50.8	551	627	704	782	860	938	1,017	1,095	1,174	1,253
	<b>DK35Z250M</b> <b>DK35H250M</b>	44.5					847	925				
	<b>DK50Z250M</b> <b>DK50H250M</b>	50.8					852	930				
300	<b>DK75Z250M</b> <b>DK75H250M</b>	63.5					863	941				
	<b>DK100Z250M</b> <b>DK100H250M</b>	70					868	947				
	<b>DK120Z250M</b> <b>DK120H250M</b>	75					872	950				
	<b>DK19300 R.F</b>	65	652	743	836	929	1,023	1,117	1,211	1,306	1,400	1,495
	<b>S.M</b>	34.9	635	726	819	912	1,006	1,100	1,194	1,288	1,383	1,478
	<b>DK25300 R.F</b>	80	664	755	848	941	1,035	1,129	1,223	1,318	1,412	1,507
<b>S.M</b>	40.1	640	732	824	917	1,011	1,105	1,199	1,294	1,388	1,483	
<b>DK32300 R.F</b>	100	680	771	864	957	1,051	1,145	1,239	1,334	1,428	1,523	
<b>S.M</b>	44.5	645	736	828	922	1,015	1,109	1,204	1,298	1,393	1,487	
<b>DK50300 R.F</b>	125	700	791	884	977	1,071	1,165	1,259	1,354	1,448	1,543	
<b>S.M</b>	50.8	651	742	835	928	1,022	1,116	1,210	1,304	1,399	1,494	
300	<b>DK65300 R.F</b>	140	712	803	896	989	1,083	1,177	1,271	1,366	1,460	1,555
	<b>S.M</b>	57.1	657	749	841	934	1,028	1,122	1,216	1,311	1,405	1,500
	<b>DK50Z300M</b> <b>DK50H300M</b>	50.8					1,013	1,108	1,202			
	<b>DK75Z300M</b> <b>DK75H300M</b>	63.5					1,024	1,119	1,213			
	<b>DK100Z300M</b> <b>DK100H300M</b>	70					1,030	1,124	1,219			
	<b>DK120Z300M</b> <b>DK120H300M</b>	75					1,034	1,128	1,222			
	<b>DK140Z300M</b> <b>DK140H300M</b>	82					1,041	1,135	1,229			
	<b>DK160Z300M</b> <b>DK160H300M</b>	86					1,044	1,138	1,232			

**Outer Diameter of DK Conveyor Chain Sprockets: Do (Welded sheet steel type) [3]**

Pitch P	Chain No.	Roller dia. d	Outer dia. (Do)									
			6	7	8	9	10	11	12	13	14	15
350	<b>DK75Z350M</b> <b>DK75H350M</b>	63.5					1,186	1,296	1,406			
	<b>DK100Z350M</b> <b>DK100H350M</b>	70				1,192	1,301	1,411				
	<b>DK120Z350M</b> <b>DK120H350M</b>	75				1,196	1,306	1,416				
	<b>DK140Z350M</b> <b>DK140H350M</b>	82				1,202	1,312	1,422				
	<b>DK160Z350M</b> <b>DK160H350M</b>	86				1,205	1,315	1,425				
	<b>DK200Z350M</b> <b>DK200H350M</b>	97				1,215	1,324	1,434				
	<b>DK250Z350M</b> <b>DK250H350M</b>	107				1,224	1,333	1,443				
	400	<b>DK120Z400M</b> <b>DK120H400M</b>	75				1,358	1,484	1,609			
<b>DK140Z400M</b> <b>DK140H400M</b>		82				1,364	1,490	1,615				
<b>DK160Z400M</b> <b>DK160H400M</b>		86				1,367	1,493	1,618				
<b>DK200Z400M</b> <b>DK200H400M</b>		97				1,376	1,502	1,628				
<b>DK250Z400M</b> <b>DK250H400M</b>		107				1,385	1,510	1,636				
450	<b>DK32450 R.F</b>	100	980	1,117	1,256	1,396	1,536	1,677	1,819	1,960	2,102	2,244
	<b>S.M</b>	44.5	945	1,082	1,220	1,360	1,501	1,642	1,783	1,925	2,067	2,209
	<b>DK50450 R.F</b>	125	1,000	1,137	1,276	1,416	1,556	1,697	1,839	1,980	2,122	2,264
	<b>S.M</b>	50.8	951	1,088	1,227	1,367	1,507	1,648	1,789	1,931	2,073	2,215
	<b>DK65450 R.F</b>	140	1,012	1,149	1,288	1,428	1,568	1,709	1,851	1,992	2,134	2,276
	<b>S.M</b>	57.1	957	1,094	1,233	1,373	1,513	1,654	1,796	1,937	2,079	2,221
500	<b>DK200Z450M</b> <b>DK200H450M</b>	97				1,539	1,680	1,821				
	<b>DK250Z500M</b> <b>DK250H500M</b>	107				1,709	1,865	2,023				
600	<b>DK50600 R.F</b>	125	1,300	1,483	1,668	1,854	2,042	2,230	2,418	2,607	2,796	2,986
	<b>S.M</b>	50.8	1,251	1,434	1,619	1,805	1,992	2,180	2,369	2,558	2,747	2,937

Photo/ Sprocket

Sprocket

## Outer Diameter of DK Conveyor Chain Sprockets: Do (Cast steel type) [1]

Pitch P	Chain No.	Roller dia. d	Outer dia. (Do)									
			6	7	8	9	10	11	12	13	14	15
66.27	<b>DK08066 S.M</b>	22.2	155	175	195	216	237	257	278	299	320	341
75	<b>DK03075 R.F</b>	30	180	203	226	249	273	296	320	343	367	391
	<b>S</b>	15.9	166	189	212	235	259	282	306	329	353	377
	<b>DK07075 R.F</b>	40	182	205	228	251	275	298	322	345	369	393
	<b>S</b>	22.2	172	195	218	241	265	288	312	335	359	383
100	<b>DK03100 R.F</b>	30	230	260	291	322	354	385	416	448	479	511
	<b>S</b>	15.9	216	246	277	308	340	371	402	434	465	497
	<b>DK07100 R.F</b>	40	232	262	293	324	356	387	418	450	481	513
	<b>S</b>	22.2	222	253	284	315	346	377	401	440	472	503
	<b>DK09100 R.F</b>	45	236	266	297	328	360	391	422	454	485	517
	<b>S.M</b>	26.5	227	257	288	319	350	382	413	444	476	507
101.6	<b>DK11100 R.F</b>	50	240	270	301	332	364	395	426	458	489	521
	<b>S.M</b>	28.8	229	259	290	321	352	384	415	446	478	510
	<b>DK05101 R</b>	38.1	233	264	296	327	359	391	423	455	487	519
	<b>S</b>	20.1	223	254	286	317	349	381	413	445	477	509
	<b>DK08101 R.F</b>	44.5	239	270	301	333	364	396	428	460	492	524
	<b>S.M</b>	22.2	225	256	288	319	351	383	415	447	479	511
125	<b>DK09101 R</b>	38.1	233	264	296	327	359	391	423	455	487	519
	<b>S.M</b>	26.5	230	261	292	324	355	387	419	451	483	515
	<b>DK13101 R</b>	44.5	239	270	301	333	364	396	428	460	492	524
	<b>S.M</b>	31.8	235	266	297	329	361	392	424	456	488	521
	<b>DK03125 R.F</b>	30	280	318	357	395	435	474	513	552	592	631
	<b>S</b>	15.9	266	304	343	381	420	460	499	538	578	617
150	<b>DK07125 R.F</b>	40	282	320	359	397	437	476	515	554	594	633
	<b>S</b>	22.2	272	310	349	388	427	466	505	545	584	623
	<b>DK09125 R.F</b>	45	286	324	363	401	441	480	519	558	598	637
	<b>S.M</b>	26.5	276	315	353	392	431	470	510	549	588	628
	<b>DK11125 R.F</b>	50	290	328	367	405	445	484	523	562	602	641
	<b>S.M</b>	28.8	279	317	355	394	433	472	512	551	591	630
152.4	<b>DK03150 R.F</b>	30	330	376	422	469	515	562	610	657	704	751
	<b>S</b>	15.9	316	362	408	454	501	548	595	643	690	737
	<b>DK07150 R.F</b>	40	332	378	424	471	517	564	612	659	706	753
	<b>S</b>	22.2	322	368	414	461	508	555	602	649	696	744
	<b>DK09150 R.F</b>	45	336	382	428	475	521	568	616	663	710	757
	<b>S.M</b>	26.5	327	372	418	465	512	559	606	653	701	748
200	<b>DK11150 R.F</b>	50	340	386	432	479	525	572	620	667	714	761
	<b>S.M</b>	28.8	329	375	421	467	514	561	608	656	703	750
	<b>DK13150 R.F</b>	60	348	394	440	487	533	580	628	675	722	769
	<b>S.M</b>	31.8	332	378	424	470	517	564	612	659	706	753
	<b>DK11152 R.F</b>	50.8	345	392	439	486	534	582	630	677	726	774
	<b>S.M</b>	25.8	331	377	424	471	519	567	615	663	711	759
200	<b>DK19152 R.F</b>	57.2	351	397	444	491	539	587	635	683	731	779
	<b>S.M</b>	34.9	340	386	433	480	528	576	624	672	720	768
	<b>DK25152 R.F</b>	69.9	361	407	454	502	549	597	645	693	741	789
	<b>S.M</b>	40.1	345	391	438	486	533	581	629	677	725	773
	<b>DK11200 R.F</b>	50	440	501	562	625	687	750	813	876	939	1,002
	<b>S.M</b>	28.8	429	490	551	614	676	739	802	865	928	991
200	<b>DK13200 R.F</b>	60	448	509	571	633	695	758	821	884	947	1,010
	<b>S.M</b>	31.8	432	493	555	617	679	742	805	868	931	994
	<b>DK19200 R.F</b>	65	452	513	575	637	699	762	825	888	951	1,014
	<b>S.M</b>	34.9	435	496	558	620	682	745	808	871	934	997



**Outer Diameter of DK Conveyor Chain Sprockets: Do (Cast steel type) [2]**

Pitch P	Chain No.	Roller dia. d	Outer dia. (Do)									
			6	7	8	9	10	11	12	13	14	15
200	<b>DK25200 R.F</b>	80	464	525	587	649	711	774	837	900	963	1,026
	<b>S.M</b>	40.1	440	501	563	625	687	750	813	876	939	1,002
	<b>DK32200 R.F</b>	100	480	541	603	665	727	790	853	916	979	1,042
	<b>S.M</b>	44.5	445	505	567	629	692	754	817	880	943	1,006
	<b>DK35Z200M</b> <b>DK35H200M</b>	44.5					685	748				
	<b>DK50Z200M</b> <b>DK50H200M</b>	50.8					691	753				
225	<b>DK75Z200M</b> <b>DK75H200M</b>	63.5					701	764				
	<b>DK50Z225M</b> <b>DK50H225M</b>	50.8					771	841				
250	<b>DK19250 R.F</b>	65	552	628	705	783	861	939	1,018	1,097	1,175	1,254
	<b>S.M</b>	34.9	535	611	688	766	844	922	1,001	1,080	1,158	1,237
	<b>DK25250 R.F</b>	80	564	640	717	795	873	951	1,030	1,109	1,187	1,266
	<b>S.M</b>	40.1	540	616	693	771	849	927	1,006	1,085	1,164	1,243
	<b>DK32250 R.F</b>	100	580	656	733	811	889	967	1,046	1,125	1,203	1,282
	<b>S.M</b>	44.5	545	621	698	775	854	932	1,010	1,089	1,168	1,247
	<b>DK50250 R.F</b>	125	600	676	753	831	909	987	1,066	1,145	1,223	1,302
	<b>S.M</b>	50.8	551	627	704	782	860	938	1,017	1,095	1,174	1,253
	<b>DK35Z250M</b> <b>DK35H250M</b>	44.5					847	925				
	<b>DK50Z250M</b> <b>DK50H250M</b>	50.8					852	930				
	<b>DK75Z250M</b> <b>DK75H250M</b>	63.5					863	941				
	<b>DK100Z250M</b> <b>DK100H250M</b>	70					868	947				
<b>DK120Z250M</b> <b>DK120H250M</b>	75					872	950					
300	<b>DK19300 R.F</b>	65	652	743	836	929	1,023	1,117	1,211	1,306	1,400	1,495
	<b>S.M</b>	34.9	635	726	819	912	1,006	1,100	1,194	1,288	1,383	1,478
	<b>DK25300 R.F</b>	80	664	755	848	941	1,035	1,129	1,223	1,318	1,412	1,507
	<b>S.M</b>	40.1	640	732	824	917	1,011	1,105	1,199	1,294	1,388	1,483
	<b>DK32300 R.F</b>	100	680	771	864	957	1,051	1,145	1,239	1,334	1,428	1,523
	<b>S.M</b>	44.5	645	736	828	922	1,015	1,109	1,204	1,298	1,393	1,487
	<b>DK50300 R.F</b>	125	700	791	884	977	1,071	1,165	1,259	1,354	1,448	1,543
	<b>S.M</b>	50.8	651	742	835	928	1,022	1,116	1,210	1,304	1,399	1,494
	<b>DK65300 R.F</b>	140	712	803	896	989	1,083	1,177	1,271	1,366	1,460	1,555
	<b>S.M</b>	57.1	657	749	841	934	1,028	1,122	1,216	1,311	1,405	1,500
	<b>DK50Z300M</b> <b>DK50H300M</b>	50.8					1,013	1,108	1,202			
	<b>DK75Z300M</b> <b>DK75H300M</b>	63.5					1,024	1,118	1,213			
	<b>DK100Z300M</b> <b>DK100H300M</b>	70					1,030	1,124	1,219			
	<b>DK120Z300M</b> <b>DK120H300M</b>	75					1,034	1,128	1,222			
<b>DK140Z300M</b> <b>DK140H300M</b>	82					1,041	1,135	1,229				
<b>DK160Z300M</b> <b>DK160H300M</b>	86					1,044	1,138	1,232				

## Outer Diameter of DK Conveyor Chain Sprockets: Do (Cast steel type) [3]

Pitch P	Chain No.	Roller dia. d	Outer dia. (Do)									
			6	7	8	9	10	11	12	13	14	15
350	<b>DK75Z350M</b> <b>DK75H350M</b>	63.5					1,186	1,296	1,406			
	<b>DK100Z350M</b> <b>DK100H350M</b>	70					1,192	1,301	1,411			
	<b>DK120Z350M</b> <b>DK120H350M</b>	75					1,196	1,306	1,416			
	<b>DK140Z350M</b> <b>DK140H350M</b>	82					1,202	1,312	1,422			
	<b>DK160Z350M</b> <b>DK160H350M</b>	86					1,205	1,315	1,425			
	<b>DK200Z350M</b> <b>DK200H350M</b>	97					1,215	1,324	1,434			
	<b>DK250Z350M</b> <b>DK250H350M</b>	107					1,224	1,333	1,443			
	400	<b>DK120Z400M</b> <b>DK120H400M</b>	75					1,358	1,484	1,609		
<b>DK140Z400M</b> <b>DK140H400M</b>		82					1,364	1,490	1,615			
<b>DK160Z400M</b> <b>DK160H400M</b>		86					1,367	1,493	1,618			
<b>DK200Z400M</b> <b>DK200H400M</b>		97					1,376	1,502	1,628			
<b>DK250Z400M</b> <b>DK250H400M</b>		107					1,385	1,510	1,636			
450	<b>DK32450 R.F</b>	100	980	1,117	1,256	1,396	1,536	1,677	1,819	1,960	2,102	2,244
	<b>S.M</b>	44.5	945	1,082	1,220	1,360	1,501	1,642	1,783	1,925	2,067	2,209
	<b>DK50450 R.F</b>	125	1,000	1,137	1,276	1,416	1,556	1,697	1,839	1,980	2,122	2,264
	<b>S.M</b>	50.8	951	1,088	1,227	1,367	1,507	1,648	1,789	1,931	2,073	2,215
450	<b>DK65450 R.F</b>	140	1,012	1,149	1,288	1,428	1,568	1,709	1,851	1,992	2,134	2,276
	<b>S.M</b>	57.1	957	1,094	1,233	1,373	1,513	1,654	1,796	1,937	2,079	2,221
450	<b>DK200Z450M</b> <b>DK200H450M</b>	97					1,539	1,680	1,821			
	<b>DK250Z500M</b> <b>DK250H500M</b>	107					1,709	1,865	2,023			
600	<b>DK50600 R.F</b>	125	1,300	1,483	1,668	1,854	2,042	2,230	2,418	2,607	2,796	2,986
	<b>S.M</b>	50.8	1,251	1,434	1,619	1,805	1,992	2,180	2,369	2,558	2,747	2,937

**Pitch Diameter of Conveyor Chain Sprockets: Dp**

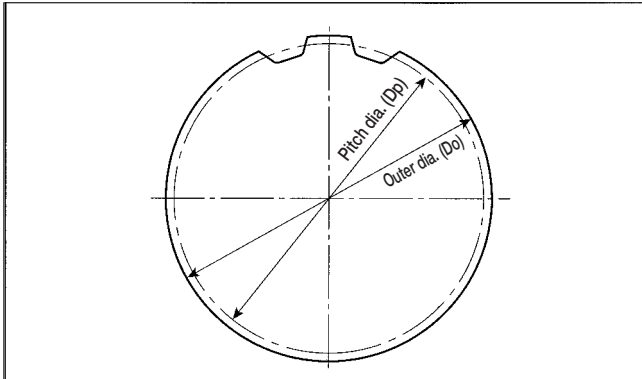

Pitch P	Pitch dia. (Dp)									
	6	7	8	9	10	11	12	13	14	15
66.27	132.5	152.7	173.2	193.8	214.5	235.2	256.0	276.9	297.8	318.7
75	150.0	172.9	196.0	219.3	242.7	266.2	289.8	313.4	337.0	360.7
100	200.0	230.5	261.3	292.4	323.6	354.9	386.4	417.9	449.4	481.0
101.6	203.2	234.2	265.5	297.1	328.8	360.6	392.6	424.5	456.6	488.7
125	250.0	288.1	326.6	365.5	404.5	443.7	483.0	522.3	561.7	601.2
150	300.0	345.7	392.0	438.6	485.4	532.4	579.6	626.8	674.1	721.5
152.4	304.8	351.2	398.2	445.6	493.2	540.9	588.8	636.8	684.9	733.0
200	400.0	461.0	522.6	584.8	647.2	709.9	772.7	835.7	898.8	961.9
225	450.0	518.6	588.0	657.9	728.1	798.6	869.3	940.2	1,011.1	1,082.2
250	500.0	576.2	653.3	731.0	809.0	887.4	965.9	1,044.6	1,123.5	1,202.4
300	600.0	691.4	783.9	877.1	970.8	1,064.8	1,159.1	1,253.6	1,348.2	1,442.9
350	700.0	806.7	914.6	1,023.3	1,132.6	1,242.3	1,352.3	1,462.5	1,572.9	1,683.4
400	800.0	921.9	1,045.3	1,169.5	1,294.4	1,419.8	1,545.5	1,671.4	1,797.6	1,923.9
450	900.0	1,037.1	1,175.9	1,315.7	1,456.2	1,597.3	1,738.7	1,880.4	2,022.3	2,164.4
500	1,000.0	1,152.4	1,306.6	1,461.9	1,618.0	1,774.7	1,931.9	2,089.3	2,247.0	2,404.9
600	1,200.0	1,382.9	1,567.9	1,754.3	1,941.6	2,129.7	2,318.2	2,507.1	2,696.4	2,885.8

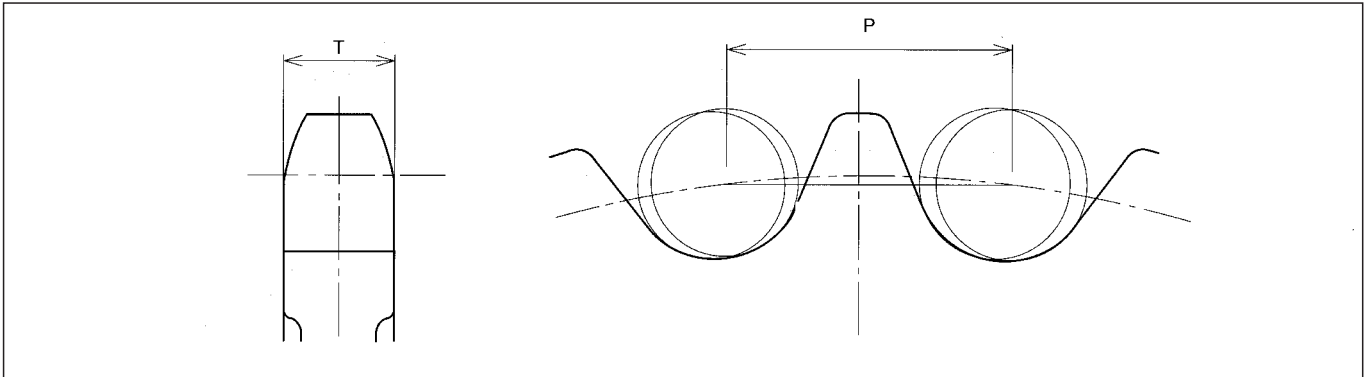
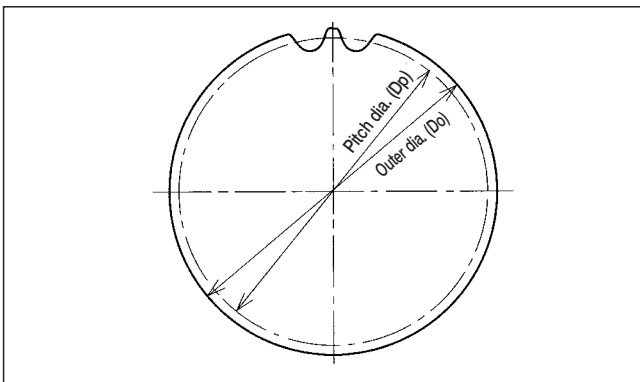
**Conveyor Chain Sprocket for NSE-type Bucket Elevator No. of Teeth: 24****Dimensional Drawing****Pitch Diameter and Outer Diameter**

## Dimensions of NSE-type Conveyor Chain Sprockets

**Welded sheet steel type    No. of teeth : 24**

Unit (mm)

Pitch <b>P</b>	Chain No.	Roller dia. <b>d</b>	Pitch dia. <b>Dp</b>	Outer dia. <b>Do</b>	Tooth width <b>T</b>	
					Driving	Driven
76.2	DK 19076M	38.1	583.8	616	28	28
	DK 28076M					
100	DK 23100M	44.5	766.1	804	40	40
	DK 35Z100M	50.8		810	45	45
	DK 32100M					
	DK 50Z100M					
125	DK 50Z125M	50.8	957.7	1,001	45	45
	DK 75Z125M	63.5		1,010	55	50
	DK100Z125M	70		1,014	—	55
	DK120Z125M	75		1,020	—	—
150	DK 75Z150M	63.5	1,149.2	1,202	55	50
	DK100Z150M	70		1,209	—	55
	DK120Z150M	75		1,212	72	63
	DK140Z150M	82		1,218	74	64
175	DK 75Z175M	63.5	1,340.7	1,395	55	50
	DK100Z175M	70		1,400	—	55
	DK120Z175M	75		1,404	—	—
	DK140Z175M	82		1,410	—	—
	DK160Z175M	86		1,412	—	—
	DK200Z175M	97		1,420	—	—

**Cast steel type    No. of teeth : 24**

Unit (mm)

Pitch <b>P</b>	Chain No.	Roller dia. <b>d</b>	Pitch dia. <b>Dp</b>	Outer dia. <b>Do</b>	Tooth width <b>T</b>	
					Driving	Driven
76.2	DK 19076M	38.1	583.8	616	29	29
	DK 28076M					
100	DK 23100M	44.5	766.1	804	42	39
	DK 35Z100M	50.8		810	47	43
	DK 32100M					
	DK 50Z100M					
125	DK 50Z125M	50.8	957.7	1,001	47	43
	DK 75Z125M	63.5		1,010	56	50
	DK100Z125M	70		1,014	65	57
	DK120Z125M	75		1,020	72	63
150	DK 75Z150M	63.5	1,149.2	1,202	56	50
	DK100Z150M	70		1,209	65	57
	DK120Z150M	75		1,212	72	63
	DK140Z150M	82		1,218	74	64
175	DK 75Z175M	63.5	1,340.7	1,395	56	50
	DK100Z175M	70		1,400	65	57
	DK120Z175M	75		1,404	72	63
	DK140Z175M	82		1,410	74	64
	DK160Z175M	86		1,412	82	70
	DK200Z175M	97		1,420	84	72

## Shaft diameter and hub dimensions

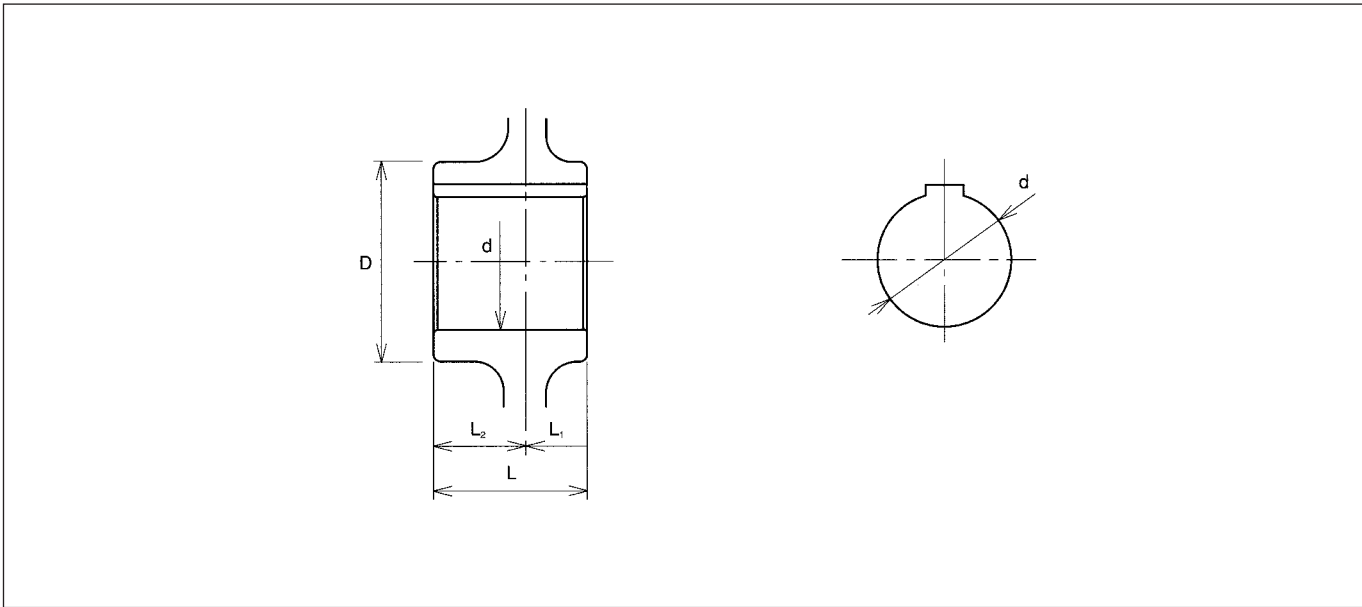

### Standard hub dimensions

Unit (mm)

Shaft dia. range <b>d</b>	Hub dia. <b>D</b>	Hub width		
		<b>L</b>	<b>L<sub>1</sub></b>	<b>L<sub>2</sub></b>
<b>50</b> ≥	85	75	30	45
<b>50</b> < <b>65</b> ≥	110	75	30	45
<b>65</b> <b>85</b>	140	100	40	60
<b>85</b> <b>110</b>	180	130	50	80
<b>110</b> <b>145</b>	225	170	70	100
<b>145</b> <b>180</b>	270	200	90	110
<b>180</b> <b>225</b>	340	235	110	125
<b>225</b> <b>260</b>	400	270	120	150
<b>260</b> <b>315</b>	480	300	130	170

### Key slot dimensions

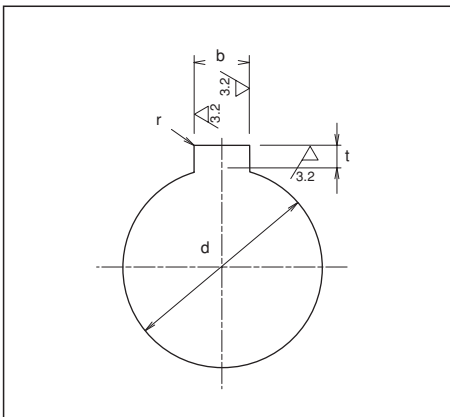

### Parallel key slot dimensions (Old JIS)

Unit (mm)

Nominal dimension	Shaft dia. range		Key slot		
	<b>d</b>		<b>b</b>	<b>t</b>	<b>r</b>
12×8	< 40	≥ 50	12	3.5	0.6
15×10	50	60	15	5	
18×12	60	70	18	6	1.0
20×13	70	80	20	6	
24×16	80	95	24	8	
28×18	95	110	28	9	
32×20	110	125	32	10	1.6
35×22	125	140	35	11	
38×24	140	160	38	12	
42×26	160	180	42	13	
45×28	180	200	45	14	
50×31.5	200	224	50	15.5	
56×35.5	224	250	56	17.5	2.5
63×40	250	280	63	20	
71×45	280	315	71	22.5	
80×50	315	355	80	25	

### Parallel key slot dimensions (New JIS)

Unit (mm)

Nominal dimension	Shaft dia. range		Key slot		
	<b>d</b>		<b>b</b>	<b>t</b>	<b>r</b>
12×8	< 38	≥ 44	12	3.3	0.4
14×9	44	50	14	3.8	
16×10	50	58	16	4.3	
18×11	58	65	18	4.4	
20×12	65	75	20	4.9	0.6
22×14	75	85	22	5.4	
25×14	85	95	25	5.4	
28×16	95	110	28	6.4	
32×18	110	130	32	7.4	1.0
36×20	130	150	36	8.4	
40×22	150	170	40	9.4	
45×25	170	200	45	10.4	
50×28	200	230	50	11.4	1.6
56×32	230	260	56	12.4	
63×32	260	290	63	12.4	
70×36	290	330	70	14.4	
80×40	330	380	80	15.4	2.5

## DK Detachable Teeth Sprockets

PAT.

Any damage on the teeth surfaces of a sprocket diminishes the life of the conveyor chain. With conventional sprockets, considerably worn sprocket teeth were repaired by teeth padding or the entire sprocket was replaced. In either case, repair was costly and with teeth padding, accuracy was impaired. We developed new sprockets with detachable teeth for independent replacement. This sprocket is highly rated by our customers for the dramatic savings in cost and time.

### Structure

The teeth can be replaced by two methods: individual tooth replacement or sectional teeth replacement.

The bolts and nuts used for mounting the teeth on to the sprocket are spot-welded to prevent loosening.

The respective structures are illustrated on the right.



### Sprocket for individual tooth replacement

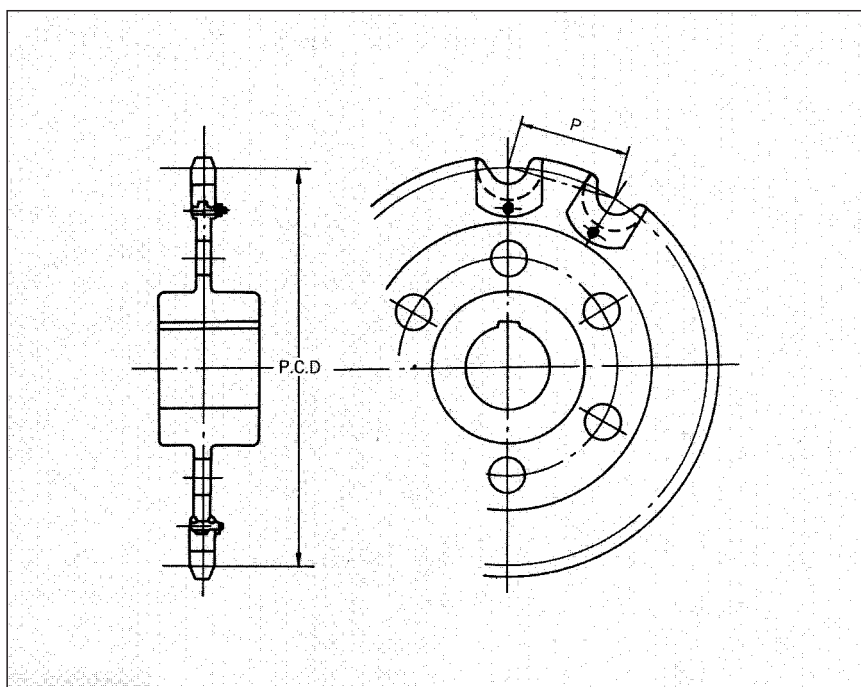

### Sprocket for sectional teeth replacement (example: division by four sections)

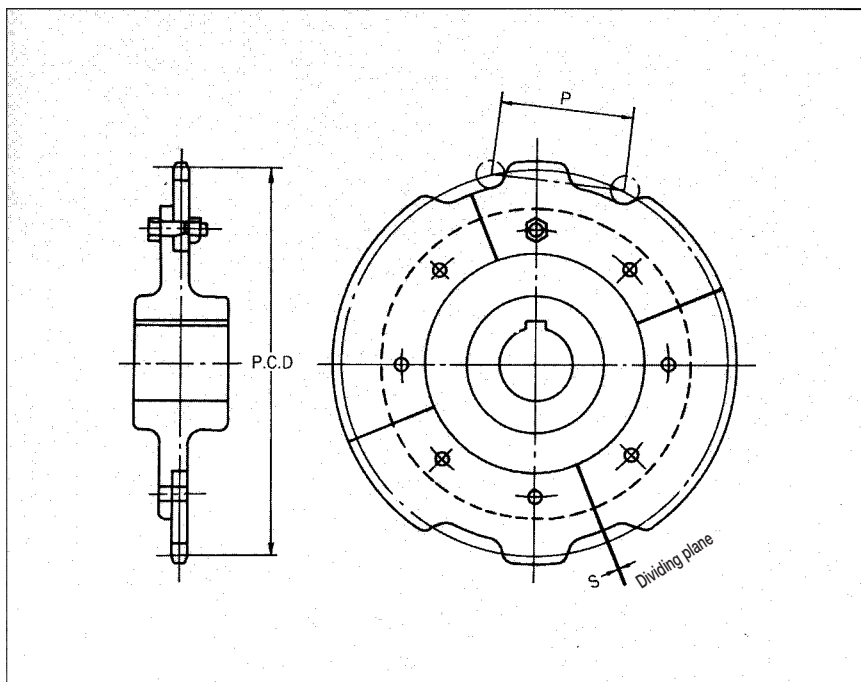

Note: Ask us for the delivery time.

The above photo and the top right illustration show a sprocket for individual tooth replacement. Since the joint face between the replaced teeth and the sprocket is formed in a unique arc, the bonding accuracy is high and the sprocket strength is enhanced. Furthermore, since the load acting on the mounting bolts is decreased, there is less possibility of loosening. This sprocket construction is patented.

There are two types of hubs: cast steel and welded sheet steel hubs. Cast steel hubs are used for large sprockets receiving heavy loads and welded sheet steel hubs for other applications.



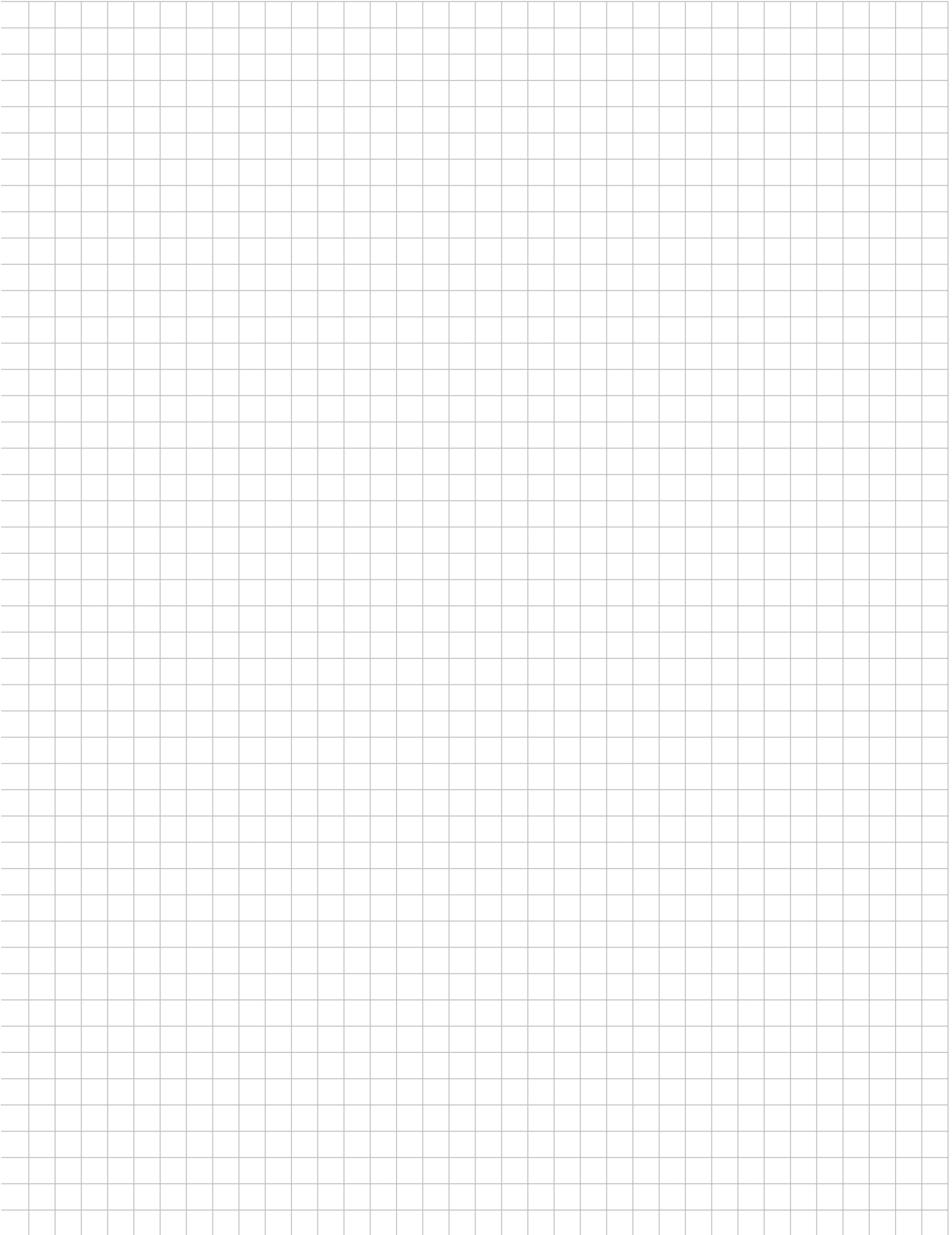

## Chain Selection

To fully exhibit its superb features, a chain conveyor must match the application. Select the most suitable chain by accurately identifying the characteristics of the chain conveyor system and service conditions (types and properties of the load, conveyance capacity, speed, distance, service environment, etc.). Refer to the selection flowchart below, and the details on each step of the selection procedure.

## Selection Flowchart

Though comprehensive knowledge and experience are required for selecting chains, a general selection procedure is described here to assist you in selecting the optimal conveyor chain.

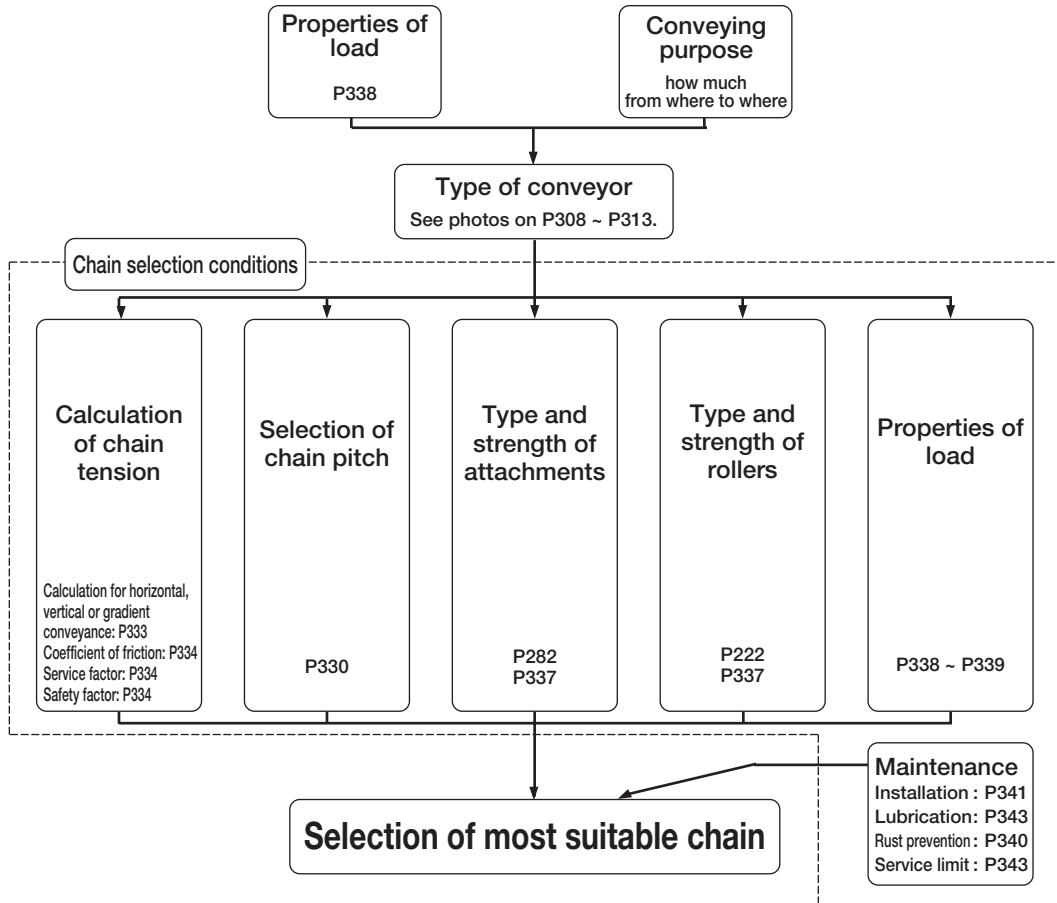

## Selection of Chain Pitch

In general, a chain with a smaller pitch travels more smoothly and lasts longer as it receives less shock. However, its larger number of links results in an increase of the entire weight, diminishing cost efficiency. Conversely, a chain with a larger pitch receives more shock which shortens chain life and causes noise. The chain pitch is decided by considering the operation speed and the sprocket teeth number. In general, use the chain at or lower than the allowable chain speed shown in the graph on the right.

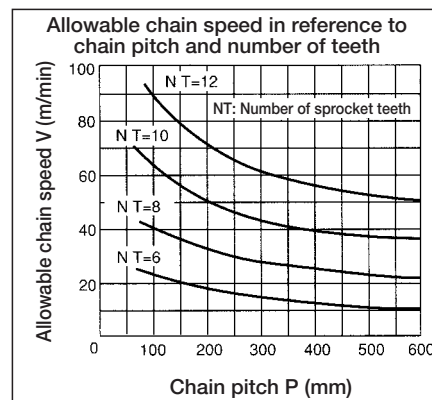

## For Use at High-temperature

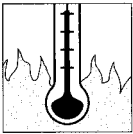

Chains strength is diminished by high-temperature atmosphere, direct conveying of high-temperature loads, or radiated heat, etc. The service limit at high-temperature depends not on the temperature of the

service environment but the temperature and material of the chain body.

Following conditions may occur when chains are used at high-temperature:

- 1) High temperature brittleness and fracture by lowered hardness of heat treated material
- 2) Brittleness caused by carbide precipitation
- 3) Abnormal wear by scale
- 4) Fatigue fracture caused by repeated thermal shock (cooling and expansion)
- 5) Abnormal wear due to an increase in the coefficient of friction
- 6) Creep fracture
- 7) Fracture due to thermal fatigue of welded area
- 8) Effects caused by thermal expansion
  - Stiff links and rotation failure due to decreased clearance
  - Fatigue fracture due to lowered fitting force
- 9) Lubrication failure and stiff links due to deterioration and carbonization of lubricating oil  
Grease excellent in heat resistance include those based on silicon, graphite or molybdenum disulfide.

For use at high-temperature, high-temperature resistance bearings and stainless steel bearings are recommended.

## For Use at Low-temperature

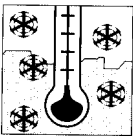

When using conveyor chains at low-temperature such as in a refrigerator or in a cold atmosphere, the following conditions may occur.

- 1) Low temperature brittleness

In general, a material is embrittled at low-temperature and shock resistance is lowered. This phenomenon is called low-temperature brittleness, and the degree of embrittlement differs from material to material.

The service limit of a conveyor chain depends on its specifications.

Variations in material and heat treatment	Service limit temperature
Standard (J,A)	-20°C
Wear resistance (P,C,D)	
With stainless steel parts (D1,D3,D5)	
Heavy-duty (K,E)	-40°C
Stainless steel (S4,S5,SH)	
Stainless steel (S3)	-100°C

- 2) Influence of freezing

At low-temperature, bending failure, roller rotation failure, fixing of chain, etc. may be caused by the freezing of penetrated water or deposited frost in the clearance between pins and bushings, bushings and rollers or inner plates and outer plates. These conditions cause an overload to act on the chain and drive, diminishing the life of the chain.

To prevent freezing, in general, it is recommended to fill the clearances with a low-temperature lubricant suitable to the service temperature to prevent water, frost, etc. from penetrating the respective portions of the chain. For lubrication, a silicon based grease is recommended.

## For Use in Dusty Environment

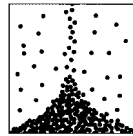

When using chains in an environment of dirt, sand, dust, etc., periodically wash and lubricate the chain. For greasing, use a grease gun to allow the lubricant to sufficiently penetrate into the clearances

between pins and bushings, bushings and rollers, and outer plates and inner plates. When using chains in a highly abrasive environment, we recommend the following:

- 1) Select a conveyor designed to prevent the chains from coming into contact with the abrasive loads, or cover the chain.
- 2) Select a chain with the largest size possible to reduce the face pressure of bearing portions such as between pins and bushings.
- 3) Keep the chain speed as low as possible.
- 4) Make grease holes in the pins and bushings, and lubricate with grease nipples.  
(Consult us when drilling pins and bushings as they are reinforced parts.)

For dusty environments and highly abrasive environments, high wear resistant bearings such as chain, DJ, Diesten and Dimec bearings are available.

## For Use in Circumstances Exposed to Water or Sea Water Drops

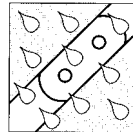

When chains are exposed to rainwater or sea water drops, lowering of strength and brittleness by corrosion, sudden wear, bending failure by rusting and roller rotation failure etc. occur. In such cases, depending

on the situation, stainless steel or high guard chains or chains with stainless steel parts are recommended. The high guard chains are highly rated by our customers. For using chains under water, see the following "For In-water Use".

## For In-water Use

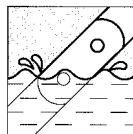

When using chains in water or sea water, brittle fracture and corrosion must be taken into consideration in addition to the adverse conditions stated in the above section. For this purpose, we manufacture Water

Treatment Conveyor Chains including Traveling Water Screen Transfer Chain, Rake Chain, Sewage Treatment Chain, BT Bushing Chain for Water Treatment Drive Unit.

Chains with stainless steel parts, with specially coated plates or stainless steel chains are recommended.

Furthermore, as corrosion resistant bearings which can be used in-water, stainless steel, Diesten and Dimec bearings are available.

## For Use in Acidic or Alkali Environments

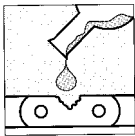

In acidic or alkali environments, stress corrosion, hydrogen embrittlement, intergranular corrosion, etc. are caused in addition to common problems encountered in other corrosive environments. Section "5-4 Corrosion Resistance Against Various Substances" lists the corrosion resistance of chain materials to various substances.

Particularly, components made of 13Cr stainless steel may rust depending on conditions.

\* For use in a corrosive environment, please let us know the name and properties of the articles to be conveyed, service conditions (temperature, load, etc.), materials of parts used around the chain (rails, covers, tanks, etc.) using the "Inquiry Sheet (Conveyor Chain)" on P344.

## Lubrication

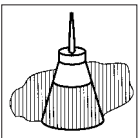

Chain life is extended by periodical lubrication. Lubrication also reduces the required power. However, note that, under some service conditions, lubrication may adversely affect the chain, or be regulated

by law, etc.

### • Lubricating oils

SAE	Temperature
SAE30	-10°C ~ 0°C
SAE40	0°C ~ 40°C

### • Lubrication intervals

It is a general rule to lubricate about once a week, but depending on the conditions during operation and the state of lubricating oil, lubricate as needed.

As lubrication methods, coating or drip lubrication is recommended. As for the locations of lubrication, see the following illustration.

For effective lubrication, clean the chain before lubrication. Select a lubrication method suitable for the specific service condition.

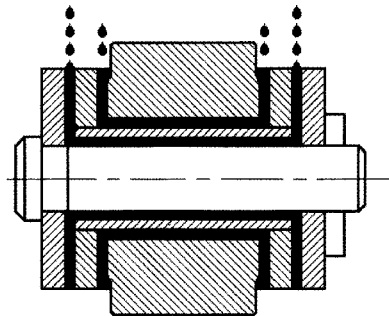

### • Automatic lubrication (oiling) device

We have various automatic lubrication (oiling) devices. Consult us if you are using chains in a setup where lubrication is difficult or if you plan to automate lubrication.

## When Lubrication Is Not Possible

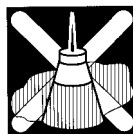

Lubrication is absolutely necessary for extending the life of the chain. However, under some conditions, lubrication may not be practical.

Avoid lubrication in the following cases:

- 1) The chain is embedded in the loads (granular material, powder, etc.).
- 2) Granular material and powder deposit on the chain when carried by pan or apron conveyors. Here, lubrication works adversely.
- 3) The chain temperature becomes high.
- 4) Conditions in which lubrication is prohibited by regulations or laws.

When the chain cannot be lubricated or is being used to convey food, we recommend using our resin, oilless or stainless steel bearings.

## For Use with Food

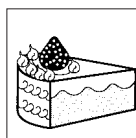

When using chains for driving or conveying within a food processing machine, especially when the food directly contacts the chain, stainless steel is required by FDA regulations.

Stainless steel chains (S3) made of 18-8 stainless steel are recommended. We also manufacture chains with neat appearance that give a clean impression designed particularly for use with food products. Contact us for more information.

## Calculation Formula for Horizontal, Vertical and Gradient Conveyance

The maximum static tension acting on the chain can be calculated from the following formula.

### Specifications of conveyor

T : Max. tension applied to the chain	Unit kN
Q : Max. conveyance capacity	t/h
S : Conveyance speed	m/min
V : Vertical center distance between sprocket shafts	m
H : Horizontal center distance between sprocket shafts	m
L : Center distance between sprocket shafts	m
M : Weight of traveling parts (weight of chain, slats, buckets, etc.)	kg/m
f <sub>1</sub> : Coefficient of friction between chain and guide rail	
f <sub>2</sub> : Coefficient of friction between conveyed articles and bottom and/or side plates	
η : Mechanical transmission efficiency of drive	
kW : Required power	kW
g : Gravitational acceleration 9.80665m/S <sup>2</sup>	
W : Total weight of conveyed articles on the conveyor (maximum value)	kg

Countable object :  $W = \frac{L \text{ (m)}}{\text{Intervals of loads (m)}} \times \text{Weight per unit of loads (kg)}$

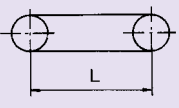
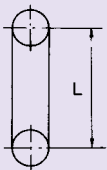
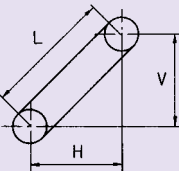
Conveyor layout	Conveyance method	Load type	Formula
<b>Horizontal</b>  	Conveys loads on it (Slat conveyor, apron conveyor, etc.)	Countable object	$T = (W + 2.1 \times M \times L) \times f_1 \times \frac{g}{1,000}$ $kW = \frac{T \times S}{5,320 \times \eta}$
		Bulk	$T = (16.7 \times \frac{Q}{S} + 2.1 \times M) \times L \times f_1 \times \frac{g}{1,000}$ $kW = \frac{T \times S}{5,320 \times \eta}$
	Conveys by scraping (Continuous flow conveyor, scraper conveyor, etc.)	Bulk	$T = (16.7 \times \frac{Q}{S} \times f_2 + 2.1 \times M \times f_1) \times L \times \frac{g}{1,000}$ $kW = \frac{T \times S}{52.2 \times \eta}$
<b>Vertical</b>  	Conveys loads on it (Bucket elevator, tray elevator, etc.)	Countable object	$T = (W + M \times L) \times \frac{g}{1,000}$ $kW = \frac{W \times L \times S}{52.2 \times \eta}$
		Bulk	$T = (16.7 \times \frac{Q}{S} + M) \times (L + 2) \times \frac{g}{1,000}$ $kW = \frac{T \times S}{52.2 \times \eta}$
<b>Gradient</b>  	Conveys loads on it (Slat conveyor, apron conveyor, etc.)	Countable object	$T = (W + M \times L) \times \frac{H \times f_1 + V}{L} \times \frac{g}{1,000}$ $+ 1.1 \times M \times (H \times f_1 - V) \times \frac{g}{1,000}$ $kW = \frac{S}{52.2 \times \eta} \times \{T - M \times (V - H \times f_1) \times \frac{g}{1,000}\}$
		Bulk	$T = (16.7 \times \frac{Q}{S} + M) \times (H \times f_1 + V) \times \frac{g}{1,000}$ $+ 1.1 \times M \times (H \times f_1 - V) \times \frac{g}{1,000}$ $kW = \frac{S}{52.2 \times \eta} \times \{T - M \times (V - H \times f_1) \times \frac{g}{1,000}\}$
	Conveys by scraping (Continuous flow conveyor, scraper conveyor, etc.)	Bulk	$T = 16.7 \times \frac{Q}{S} \times (H \times f_2 + V) \times \frac{g}{1,000}$ $+ M \times (H \times f_1 + V) \times \frac{g}{1,000}$ $+ 1.1 \times M \times (H \times f_1 - V) \times \frac{g}{1,000}$ $kW = \frac{S}{52.2 \times \eta} \times \{T - M \times (V - H \times f_1) \times \frac{g}{1,000}\}$
Note: If the results of $H \times f_1 - V$ and/or $V - H \times f_1$ are less than zero, adopt zero for those values.			

\* About 10% power loss was estimated and included in the value 52.2 used in the above formulas.

## Coefficient of Friction

### Value of coefficient of friction $f_1$

Table 1

Coefficient of friction for chains with rollers running on guide rails

Note: 1. The value may depend on the service temperature, etc.  
2. The listed values are for ambient temperature.

Roller dia.	With lubrication	Without lubrication
$D < 50$	0.15	0.20
$50 \leq D < 65$	0.14	0.19
$65 \leq D < 75$	0.13	0.18
$75 \leq D < 100$	0.12	0.17
$100 \leq D$	0.11	0.16
Without rollers (when bushings slide on a rail)	0.2~0.3	0.30~0.45
Rollers with built-in bearings	0.035~0.050	

Table 2

Coefficient of friction for chains with plates sliding on guide rails

Temperature (°C)	With lubrication	Without lubrication
Ambient temperature ~ 400	0.20	0.30
400~600	0.30	0.35
600~800	0.35	0.40
800~1000	—	0.45

### Value of coefficient of friction $f_2$

Table 3

Coefficient of friction with loads and bottom and/ or side plates

Note: Figure  $f_2$  is changed by the condition of grading and/ or humidity

Load to be conveyed	$f_2$
Coal	0.30~0.70
Coke	0.35~0.70
Ash	0.45~0.65
Sand	0.55~0.90
Sandstone	0.55~0.70
Ore	0.45~0.70
Cement	0.60~0.75
Cereal	0.35~0.45
Limestone	0.35~0.55

## Safety Factor and Determination of Chain Size

Multiply the chain tension calculated in 5-1-2 by the safety factor corresponding to the chain speed and by the service factor to obtain the required strength of the chain. If the calculated strength does not satisfy chain tensile strength, select a chain one step higher in strength, or a strong type chain, and re-calculate.

Select a chain size that fulfills the following condition:

$$\text{Average tensile strength} > \text{Calculated chain tension} \times K_s \times K_e$$

The service factor under good service conditions is set as 1.0. Refer to the table on the right for other service conditions. The values are given considering possible shock loads, service environment, lubrication condition, service time per day, etc.

(Reference) Good service conditions refer to the following:

1. The load is mostly constant and uniform.
2. There are no shock loads when loading and unloading.
3. Service environment is good. (Close to ambient temperature without abrasive or corrosive factors)
4. Minimal wear due to appropriate lubrication.

### Safety factor $K_s$ by chain speed $K_s$

Chain speed	Safety factor $K_s$
30m/min or less	7 or more
30~40m/min	8 or more
40~50m/min	9 or more
50~60m/min	10 or more

### Service factor $K_e$

	Service factor $K_e$	
	Service time per day	
	10 hours or less	10 ~24 hours
Good	1.0	1.2
Fair	1.2	1.4
Bad	1.5~2.0	1.8~2.5

In any special environment (when the temperature of chain is higher than 200°C, or wet or abrasive or corrosive articles are conveyed, etc.), the environment must be carefully examined when determining chain size. Consult us in such cases.

## Examples of Calculation for Selection

### Selection case I

A powder is horizontally scraped to be conveyed by a scraper conveyor.

### Specifications

Conveyor type	Scraper conveyor
Max. conveyance capacity	$Q = 100$ ton/h
Conveyance speed	$S = 20$ m/min
Horizontal center distance between sprocket shafts	$L = 30$ m
Scraper installation intervals	600 mm
Weight of traveling components	$M = W_1 + W_2$
Weight of scraper	$W_1 = 30$ kg/m
Weight of chain	$W_2$

Note: Estimate  $W_2$  as 20kg/m/strand for the initial calculation.

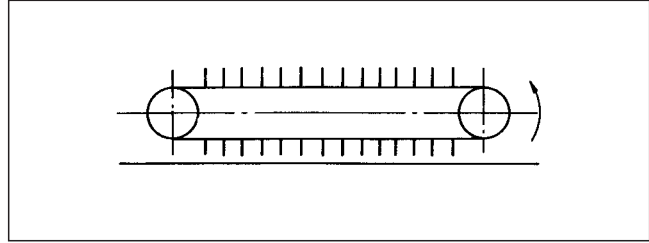

Coefficient of friction between chain and guide rail	$f_1 = 0.2$
Coefficient of friction between conveyed articles and bottom plate or side plate	$f_2 = 0.6$
Number of chain strands	2 strands

### Calculation

Apply the formula for horizontal conveyance by scraping shown in the table on P333.

$$\text{Max. chain tension } T = (16.7 \times \frac{Q}{S} \times f_2 + 2.1 \times M \times f_1) \times L \times \frac{g}{1,000}$$

$$\text{Required power } kW = \frac{T \times S}{52.2 \times \eta}$$

When the values of the above specifications are applied to these formulas,

$$T = (16.7 \times \frac{100}{20} \times 0.6 + 2.1 \times 50 \times 0.2) \times 30 \times \frac{9.80665}{1,000} = 21 \text{ kN}$$

The value of  $T$  obtained here is a tension acting on two strands. So, the chain tension per strand is  $T/2$ . Since the conveyance speed (chain speed) is 20 m/min, the safety factor  $K_s$  is 7 from the table of P334. Furthermore, for an 8-hour operation per day with no lubrication, the service factor  $K_e$  is 1.5 from the table on P334.

$$\text{Required chain strength} = \frac{21}{2} \times 7 \times 1.5 = 110 \text{ kN}$$

Therefore, Standard Conveyor Chain DK11150F standard version can be tentatively selected as it satisfies the average tensile strength.

Then, an accurate calculation can be done with the actual weight of the selected chain.

This chain has Attachment A2 for every four links. From the dimension tables on P229, the values for the components are as follows:

Chain body weight  
Attachment weight  
Attachment installation intervals  
Hence,

$$\text{Weight of chain} = 7.90 + \frac{0.24}{0.60} = 8.3 \text{ kg/m/strand}$$

$$\text{Weight of traveling parts } M = 30 + 8.3 \times 2 = 46.6 \text{ kg/m}$$

Therefore, the maximum service chain tension is

$$T = (16.7 \times \frac{100}{20} \times 0.6 + 2.1 \times 46.6 \times 0.2) \times 30 \times \frac{9.80665}{1,000} = 20.5 \text{ kN}$$

The chain tension per strand is

$$\frac{20.5}{2} \times 7 \times 1.5 = 108 \text{ kN} < 112 \text{ kN}$$

Hence, the chain size to be selected is DK11150F-4P12 standard version.

$$\text{Conveyor chain safety factor } Sf = \frac{112 \times 2}{20.5} = 11$$

Required power (when the mechanical transmission efficiency of drive is 0.8) is

$$kW = \frac{20.5 \times 20}{52.2 \times 0.8} = 9.8 \text{ kW}$$



## Selection case I

A conveyor chain for bucket elevator conveying a powder vertically using buckets.

### Specifications

Conveyor type	Guide discharge type bucket elevator
Max. conveyance capacity	Q = 250 ton/h
Conveyance speed	S = 25 m/min
Horizontal center distance between sprocket shafts	L = 20 m
Weight of bucket	W <sub>1</sub> = 60 kg/m
Weight of chain	W <sub>2</sub>
(Estimate W <sub>2</sub> as 20kg/m/strand for the initial calculation.)	
Bucket installation intervals	500 mm
Chain pitch	250 mm
Number of chain strands	2 strands

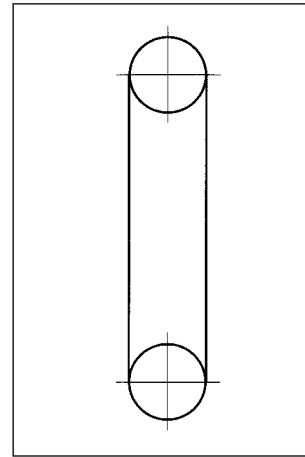

### Calculation

Apply the formula for horizontal conveyance by scraping shown in the table on P333.

Weight of traveling components per 1m  $M = W_1 + 2 \times W_2 = 60 + 2 \times 20 = 100 \text{ kg/m}$

$$\text{Max. chain tension } T = (16.7 \times \frac{Q}{S} + M) \times (L + 2) \times \frac{g}{1,000}$$

$$\text{Required power } \text{kW} = \frac{T \times (L + 2)}{320 \times \eta}$$

When the values of the above specifications are applied to these formulas,

$$T = (16.7 \times \frac{250}{25} + 100) \times (20 + 2) \times \frac{9.80665}{1,000} = 57.6 \text{ kN}$$

The value of T obtained here is a tension acting on two chain strands. So, the chain tension per stands is T/2.

Since the conveyance speed (chain speed) is 25 m/min, the safety factor K<sub>s</sub> is 7 from the table of P334.

Furthermore, for an 12-hour operation per day with no lubrication, engendered by poor environment, the service factor K<sub>e</sub> is 1.8 from the table on P333.

$$\text{Required chain strength} = \frac{57.6}{2} \times 7 \times 1.8 = 362.9 \text{ kN}$$

Therefore, NE Bucket Elevator Chain DK35Z250M can be tentatively selected as it satisfies the average tensile strength.

Then, an accurate calculation can be done with the actual weight of the selected chain.

Since the mass of this chain with Attachment G4 on every two links is 15kg from the dimension table on P287,

Weight of traveling components  $M = 60 + 15 \times 2 = 90 \text{ kg/m}$

Therefore, the maximum service chain tension is

$$T = (16.7 \times \frac{250}{25} + 90) \times (20 + 2) \times \frac{9.80665}{1,000} = 55.4 \text{ kN}$$

The chain tension per chain strand is

$$\frac{55.4}{2} \times 7 \times 1.8 = 349 \text{ kN} < 392 \text{ kN}$$

Hence, the chain size to be selected is DK35Z250M-2PG4.

$$\text{Conveyor chain safety factor } S_f = \frac{392 \times 2}{55.4} = 14$$

Required power (when the mechanical transmission efficiency of drive is 0.8)

$$\text{kW} = \frac{55.4 \times 25}{52.2 \times 0.8} = 33.2 \text{ kW}$$

## Allowable Loads of Rollers and Attachments

### Allowable Load of Rollers

When selecting a chain for conveyors carrying loads on them, the allowable load of rollers must be taken into account. The allowable load per roller under good service conditions is as shown in the following table.

When using Attachment A, use a roller with an allowable load smaller than that of the attachment.

The tensile strength of the rail must be 400kN/min<sup>2</sup> (41kgf/mm<sup>2</sup>) or more.

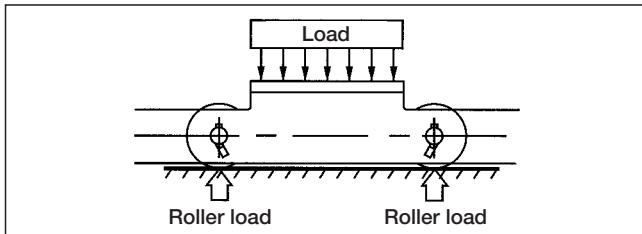

### Allowable Load of Standard Attachment A

Vertical loads from the weight of loads and slats etc. are applied on Attachment A. The allowable vertical load per attachment is as shown in the following table.

When the load is received by the rollers, use a roller with an allowable load smaller than that of the attachment.

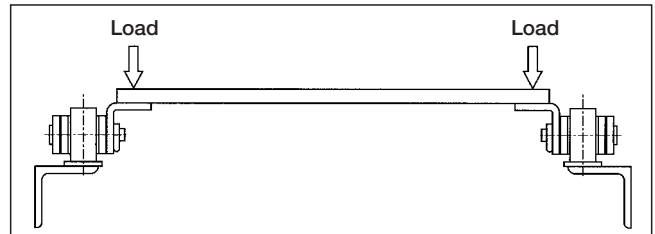

### Allowable load of roller

Unit: kN (kgf)/ roller

Chain No.	R, F-roller		S, M-roller					
	Standard (J)	Standard (A) Heavy-duty	Standard	Heavy-duty				
DK 03075 ※1 DK 03100 ※1 DK 03125 ※1 DK 03150 ※1	0.53 (55)	0.88 (90)	0.53 (55)					
DK 07075 ※1 DK 07100 ※1 DK 07125 DK 07150			0.98 (100)	1.56 (160)	0.98 (100)			
DK 09100 DK 09125 DK 09150					1.37 (140)	2.25 (230)	1.47 (150)	
DK 11100 DK 11125 DK 11150 DK 11200							1.76 (180)	2.94 (300)
DK 13150 DK 13200	2.45 (250)	4.11 (420)						
DK 19200 DK 19250 DK 19300			2.45 (250)	4.11 (420)	2.74 (280)			
DK 25200 DK 25250 DK 25300	4.31 (440)	7.15 (730)			4.51 (460)			
DK 32200 DK 32250 DK 32300 DK 32450					5.39 (550)	8.92 (910)	5.58 (570)	
DK 50250 DK 50300 DK 50450 DK 50600			7.45 (760)	12.3 (1,260)			7.45 (760)	
DK 65300 DK 65450	8.92 (910)	14.8 (1,510)					9.31 (950)	
DK 05101 ※1※2 DK 08066 ※3 DK 08101							0.98 (100)	1.66 (170)
DK 09101 ※2 DK 11152	1.27 (130)	2.15 (220)			1.27 (130)			
DK 13101 ※2 DK 19152			1.56 (160)	2.54 (260)	1.56 (160)			
DK 25152	1.66 (170)	2.84 (290)			1.66 (170)			
			2.05 (210)	3.43 (350)	2.05 (210)			
	2.45 (250)	4.02 (410)			2.74 (280)			
			3.04 (310)	5.09 (520)	3.23 (330)			

Note: ※1 : M-roller is not available. ※2 : F-roller is not available. ※3 : R-roller is not available.

### Allowable load of Attachment A

Unit: kN (kgf)/ attachment

Chain No.	Standard (J, A)		Heavy-duty
	Standard (J, A)	Standard (J, A)	
DK 03075 DK 03100 DK 03125 DK 03150	0.78 (80)	0.83 (85)	1.17 (120)
DK 07075 DK 07100 DK 07125 DK 07150	0.98 (100)	1.07 (110)	1.47 (150)
DK 09100 DK 09125 DK 09150	1.07 (110)	1.17 (120)	1.66 (170)
DK 11100 DK 11125 DK 11150 DK 11200	1.17 (120)	1.37 (140)	1.76 (180)
DK 13150 DK 13200	1.56 (160)	1.76 (180)	2.15 (220)
DK 19200 DK 19250 DK 19300	1.76 (180)	2.05 (210)	2.45 (250)
DK 25200 DK 25250 DK 25300	2.94 (300)	3.62 (370)	3.23 (330)
DK 32200 DK 32250 DK 32300 DK 32450	3.92 (400)	5.58 (570)	3.62 (370)
DK 50250 DK 50300 DK 50450 DK 50600	4.21 (430)	5.97 (610)	4.70 (480)
DK 65300 DK 65450	5.97 (610)	7.74 (790)	5.78 (590)
DK 05101 DK 08066 DK 08101	7.74 (790)	10.78 (1,100)	6.27 (640)
DK 09101 DK 11152 DK 13101 DK 19152	8.23 (840)	11.66 (1,190)	8.91 (910)
DK 25152	10.38 (1,060)	15.97 (1,630)	11.56 (1,180)
	4.31 (440)	5.58 (570)	6.27 (640)
	5.58 (570)	7.15 (730)	8.91 (910)
	8.42 (860)	10.38 (1,060)	11.56 (1,180)
	10.38 (1,060)	13.77 (1,400)	15.97 (1,630)
	6.37 (650)	8.23 (840)	8.23 (840)
	10.38 (1,060)	13.77 (1,400)	15.97 (1,630)
	1.37 (140)	2.15 (220)	2.25 (230)
	0.98 (100)	1.56 (160)	1.56 (160)
	1.76 (180)	2.74 (280)	2.74 (280)
	1.86 (190)	3.03 (310)	3.03 (310)
	2.05 (210)	3.33 (340)	3.33 (340)
	3.13 (320)	4.99 (510)	4.99 (510)
	3.33 (340)	5.29 (540)	5.29 (540)
	4.21 (430)	6.27 (640)	6.27 (640)

## Property of Loads and Recommended Chains

The following table shows chain specifications for loads in general. A specific powder or granular material belonging to the same category in the following table may differ in physical properties, depending on the place of production, manufacturer, grain form, storage condition, supply condition, temperature, humidity, etc. Confirm all the properties of the specific load when selecting the conveyor type and chain.

Loads	Properties			Recommended conveyor type					Recommended chain spec	
	Apparent specific gravity	Wear	Corrosion	Adhesion	Bucket elevator	Continuous flow conveyor	Drag chain conveyor	Scraper conveyor		Pan conveyor
Metal, ore and dust	Iron ore powder	1.6~2.4	○		○	○	○		○	K
	Iron ore lumps	1.6~2.6	○		○	○	○		○	K
	Zinc ore	1.6~2.6	○		○	○	○		○	K
	Zinc dust	0.4~0.6			○	○	○		○	A
	Manganese ore (powder)	1.3~1.5	○		○	○	○		○	K
	Nickel ore (powder)	0.9~1.2	○		○	○	○		○	K
	Copper ore (powder)	1.0~1.9	○	○		○	○		○	K
	Iron sulfide ore (powder)	1.5~2.5	○	○	○	○	○		○	K
	Bauxite	0.9~1.3	○		○	○	○		○	K
	Alumina	0.4~1.0	○		○	○	○		○	K
	Titanium oxide (lumps) (powder)	0.6~1.0	○		○	○	○		○	K
	Sintered ore	1.6~1.8	○		○	○	○		○	K
	Re-sintered ore	1.6~1.8	○		○	○	○		○	K
	Iron ore pellets	1.6~2.1	○		○	○	○		○	K
	Slag	1.0~1.2	○		○	○	○		○	K
	Casting bed dust	1.0~1.5	○		○	○	○		○	K
	Sintered dust	0.6~1.5	○		○	○	○		○	K
	Kiln exhaust gas dust	0.8~1.2	○		○	○	○		○	K
Iron oxide dust	0.3~0.6	○		○	○	○		○	K	
Coal	Coal (grains)	0.5~1.0	○		○	○	○	○	○	SH
	Coal (lumps)	0.6~0.7		○	○	○	○	○	○	SH
	Pulverized coal	0.5~0.8		○	○	○	○	○	○	SH
	Coke	0.5~0.8	○		○	○	○		○	K
	Powdery coke	0.3~0.8		○	○	○	○		○	K
Waste	Fuel oil ash	0.6~1.0		○	○	○		○	○	D1
	Sludge ash	0.6~0.8			○	○		○	○	A
	Refuse ash	0.4~0.8			○	○		○	○	A
	Wet refuse		○					○	○	D1
Cement and lime	Cement	0.8~1.2			○	○		○	○	A
	Blast furnace cement	0.8~1.2	○		○	○		○	○	K
	Cement raw material powder	0.8~1.0			○	○		○	○	A
	Cement clinker	1.2~1.6	○		○	○	○	○	○	K
	Cement cottrell dust	0.7~1.0			○	○		○	○	A
	Clinker dust	0.6~1.2	○		○	○		○	○	K
	Limestone (lumps)	1.2~1.6	○		○	○	○		○	A
	Limestone (grains)	1.0~1.4			○	○	○		○	A
	Limestone (powder)	0.9~1.0			○	○	○		○	A
	Limestone dust	0.5~0.6			○	○	○		○	A
Non-metal	Quick lime	0.7~1.2			○	○		○	○	A
	Slaked lime	0.4~0.7			○	○		○	○	A
	Dolomite	1.5~1.8	○		○	○	○		○	K
	Calcium carbonate	0.5~1.4			○	○		○	○	A
	Silica sand	1.1~1.5	○		○	○		○	○	K
	Silica rock	1.0~1.5			○	○		○	○	K
	Clay (dry)	1.0~1.6	○		○	○	○		○	D2
	Clay dust	1.1~1.6	○		○	○		○	○	D2
	Fluorite	1.7~1.8			○	○		○	○	A
	Gypsum	0.6~0.9		○	○	○		○	○	D2
Talc	0.5~0.7			○	○		○	○	A	
Feld spar	1.0~1.4	○		○	○		○	○	K	

Loads	Properties			Recommended conveyor type					Recommended chain spec	
	Apparent specific gravity	Wear	Corrosion	Adhesion	Bucket elevator	Continuous flow conveyor	Drag chain conveyor	Scraper conveyor		Pan conveyor
Non-metal	Bentonite	0.6~0.8	○		○	○		○	○	A
	Fly ash	0.7~1.6	○		○	○		○	○	K
	Magnesia clinker	1.3~1.9	○		○	○		○	○	K
	Brick stone scraps	1.3~1.5	○		○	○	○		○	K
	Soda ash (dense)	0.9~1.1			○	○		○	○	A
	Soda ash (light)	0.3~0.6			○	○		○	○	A
	Casting sand	1.5~1.8	○		○	○	○		○	K
	Crushed stone and gravel	1.2~2.0	○		○	○		○	○	K
	Raw material of ferrite	0.7~0.9			○	○		○	○	A
	Porcelain clay	0.9~1.4	○		○	○		○	○	K
	Carbide	0.6~1.3				○		○	○	A
	Urea	0.5~0.8		○	○	○		○	○	S4
	Glauber's salt	0.6~0.9		○	○	○		○	○	S4
	Anhydrous sodium sulfate	1.1~1.3		○	○	○		○	○	S4
	Sulfur powder	0.8~1.0			○	○		○	○	A
	Cullet	1.3~1.7	○		○	○		○	○	K
	PVC powder	0.5~0.7			○	○		○	○	A
	Plastic powder	0.5~0.6			○	○		○	○	A
	Synthetic detergent	0.5~0.6			○	○		○	○	A
	Carbon black	0.1~0.4	○		○	○		○	○	K
	Fine powder carbon	0.2~0.3	○		○	○		○	○	K
	Rubber powder	0.3~0.4			○	○		○	○	A
	Wood chips	0.1~0.3				○		○	○	A
Raw materials of agricultural chemicals	0.4~0.6	○	○	○	○		○	○	SH	
Phosphorus ore (powder)	0.9~1.5	○		○	○		○	○	K	
Phosphorus ore (lumps)	1.1~1.6	○		○	○		○	○	K	
Fertilizer	Phosphorus sulfide (powder)	0.7~1.0			○	○		○	○	A
	Ammonium phosphate	0.9~1.2			○	○		○	○	A
	Ammonium chloride (powder)	0.5~0.7		○	○	○		○	○	A
	Ammonium chloride (grains)	0.6~0.9		○	○	○		○	○	A
	Ammonium sulfate	0.8~1.2		○	○	○		○	○	A
	Potassium sulfate	0.5~1.3			○	○		○	○	SH
	Potassium chloride	0.7~1.0		○	○	○		○	○	SH
	Lime nitrogen	0.8~1.3	○		○	○		○	○	SH
	Calcium superphosphate	0.8~1.0		○	○	○		○	○	SH
	Compound fertilizer	0.7~1.2		○	○	○		○	○	SH
Fused phosphate	1.0~1.3	○		○	○		○	○	K	
Cereal, food and feed	Rice	0.7~0.8			○	○		○	○	A
	Barley	0.6~0.7			○	○		○	○	A
	Wheat	0.7~0.8			○	○		○	○	A
	Wheat flour	0.4~0.7			○	○		○	○	A
	Soybean	0.7~0.8	○		○	○		○	○	A
	Corn	0.7~1.0			○	○		○	○	A
	Malt	0.9~1.0			○	○		○	○	A
	Starch	0.4~0.7			○	○		○	○	A
	Sugercane	0.2~0.3			○	○		○	○	A
	Bagasse	0.1~0.2			○	○		○	○	A
	Sugar	0.8~1.0			○	○		○	○	S4 S3
	Salt (dry)	0.9~1.3		○	○	○		○	○	A
	Mixed feed	0.4~0.6	○		○	○		○	○	A

Note: 1. For the symbols of recommended chain versions, see P223.  
2. If the conveyed articles are food, please state that effect.

## Corrosion Resistance Against Various Substances

This table shows experimental data on the corrosion resistance of chains to various substances, and is not to guarantee chain performance. When selecting a chain, examine all aspects including service conditions, temperature, and load concentration.

### Corrosion of metal

When a metal is exposed to a corrosive environment, various phenomena occur. Above all, stress corrosion cracking, hydrogen embrittlement cracking, pitting corrosion etc. can cause serious accidents, and sufficient preventive measures must be taken.

#### 1) Stress corrosion cracking

Stress corrosion cracking occurs when corrosive action and static stress work simultaneously. When a metal is gradually affected as in ordinary corrosion, the timing of replacement can be relatively easy to predict. However, stress corrosion cracking causes sudden brittle fracture, and is a serious problem.

In general, most industrial alloys may crack in any environment. The corrosive materials most likely to cause stress corrosion cracking are chlorine and chlorine ion (Cl<sup>-</sup>).

Cathodic polarization can be used to prevent cracking or to slowdown the progression of cracking.

#### 2) Hydrogen embrittlement cracking

Sudden cracking may occur if processes like acid cleaning, plating, or welding are not followed by sufficient post-treatment, or if a metal is used in an acidic environment. This is because the hydrogen produced by acidic corrosion permeates and embrittles the metal. This is called "hydrogen embrittlement cracking".

Though difficult to distinguish from stress corrosion cracking, in hydrogen embrittlement cracking, the entire metal is embrittled, baking allows recovery from embrittlement, and cracking can be prevented by anodic polarization.

#### 3) Pitting corrosion

Corrosion is concentrated locally on a surface of a metal, increasing only the depth and forming corroded holes. This phenomenon is called pitting corrosion. Under conditions causing general corrosion, pitting corrosion is not common, but is one of the most damaging corrosion types especially for stainless steel. Specifically, when pitting corrosion occurs at an area receiving tensile stress, strength is extremely lowered in the worst case.

Medium	Standard	High guard	Double guard	Stainless steel	
				S4	S3
Aceton	×	○	○	○	○
Sulfurous gas (wet)	×	×	×	×	○
Sulfurous gas (dry)	—	△	△	—	○
Ammonia gas (cool)	—	○	○	—	○
Ammonia gas (hot)	×	△	△	×	×
Ammonia water	△	×	○	○	○
Ethanol	○	○	○	○	○
Sodium chloride, salt	×	○	○	×	△
Hydrochloric acid	×	×	△(pH3)	×	×
Chlorine gas (wet)	×	×	×	×	×
Sea water	×	○	○	×	△
Hydrogen peroxide	×	○	○	△	△
Caustic soda (20%)	×	×	○	○	○
Gasoline	○	○	○	○	○
Potassium permanganate	△	○	○	△	○
Formic acid	×	×	×	×	×
Milk	○	○	○	○	○
Citric acid	×	×	△(pH3)	○	○
Glycerin	△	○	○	△	○
Acetic acid (10%)	×	×	△	△	○
Bleaching powder, sodium hypochlorite	×	△	△	×	×
Carbon tetrachloride (dry)	△	○	○	△	△
Alcoholic soap (10%)	×	△	△	△	△
Oxalic acid (5%)	×	△	△	△	△
Oxalic acid (10%, boiled)	×	×	×	×	×
Nitric acid (10%)	×	×	×	△	○
Vinegar	×	○	○	×	△
Calcium hypochlorite	×	△	△	×	×
Baking soda	○	△	○	○	○
Water	×	○	○	○	○
Calcium hydroxide	△	×	×	○	○
Phenic acid, Phenol	×	×	×	△	△
Petroleum	○	○	○	○	○
Soapwater	△	○	○	○	○
Carbonic water	○	○	○	○	○
Sodium carbonate	○	○	○	○	○
Kerosene	○	○	○	○	○
Lactic acid (5%)	×	○	○	×	○
Lactic acid (10%, 65°C)	×	○	○	×	△
Paraffin	○	○	○	○	○
Beer	○	○	○	○	○
Benzene, benzol	○	○	○	○	○
Boric acid (5%)	×	×	×	○	○
Pottasium alum	×	×	×	×	△
Methanol	○	○	○	○	○
Iodine	×	×	×	×	×
Butyric acid	×	—	—	—	△
Sulfuric acid	×	×	×	×	×
Phosphoric acid (10%)	×	×	×	×	△
Sodium sulfate (5%)	△	○	○	○	○
Wine	○	○	○	○	○

Note: 1. ○: Corrosion resistant,  
 △: Corrosion resistant depending on conditions,  
 ×: No resistance  
 2. Unless specified, tests were conducted at 20 °C.

## Rust Prevention of DK Conveyor Chain

DK Conveyor Chains are coated with a rust prevention oil diluted by light oil (we call it "P oil") unless otherwise specified. Rust prevention by P oil is effective for two to three months indoors. Specify NP-2, a rust prevention oil diluted by JIS solvent, for a longer effect when using chains for export or installation work etc. For a sewage chain low in operation frequency, considering corrosion resistance during service as well, a more adhesive tarry rust preventing oil NP-1 (JIS standard) is recommended. Our rust prevention oils are listed below. Note that lubricating effect cannot be expected from these oils, and that chain lubrication is required irrespective of their use.

Rust prevention type	Features	Application
P oil	Rust prevention oil diluted by light oil	For general use
NP-2	JIS rust prevention oil with a thicker film than P oil	For export
NP-1	A more abrasive tarry JIS rust preventive oil	For sewage chain, etc.
NP-19	Transparent semi-drying powerful JIS rust prevention oil	For spare chain components
Coating	Contact us concerning a specific application	

### For your information

#### Stainless steels

Stainless steels can be classified into four types, austenitic stainless steel, ferritic stainless steel, martensitic stainless steel, and quench hardened stainless steel.

Classification and features of stainless steels

	Austenitic stainless steel	Ferritic stainless steel	Martensitic stainless steel	Quench hardened stainless steel
Name in reference to main elements	18Cr-8Ni stainless steel	18Cr stainless steel	13Cr stainless steel	17Cr-4Ni stainless steel
Typical steels	SUS 304 SUS 316	SUS 430	SUS 403 SUS 410 SUS 420 SUS 431	SUS 630
Heat treatment and features	All the alloy elements are melted into the base metal at a temperature higher than 1000°C, and the mixture is quenched. (Solution treatment) The steel is excellent in corrosion resistance and high enough in ductility to be cold-worked.	Not hardened. Since it is as soft as pure iron, it is not suitable for applications requiring strength. It is rather poor also in corrosion resistance, but since it is inexpensive, it is used instead of austenitic stainless steel.	Like ordinary steel, it is hardened and tempered. Since it is as hard as ordinary steel, it is often used. However, it is slightly poor in corrosion resistance.	Like austenitic steel, this is solution-treated, but later aging-treated to partially quench alloying ingredients for hardening, to raise the strength. It is excellent in both strength and corrosion resistance.
Corrosion resistance	High	Low	Low	Medium
Hardness	Low	Low	High	High
Viscosity	Large	Large	Large for the hardness	Large
Wear resistance	Low	Low	Large	Large
Cautions	Intergranular corrosion, pitting corrosion, and stress corrosion cracking	Sigma embrittlement and 475 °C embrittlement	Hydrogen embrittlement cracking	
Applications	Various chemical equipment High quality tableware	Stainless steel sinks Light corrosion resistant parts	Cutting tools Mechanical parts with high hardness	Mechanical parts with high strength and high corrosion resistance

SUS304, a typical austenitic stainless steel, is considered to be non-magnetic, but when used in chains, since it is cold-worked and extensively processed to achieve high-strength, it is slightly magnetic. Since the magnetism is extremely weak compared to that of iron and steel, the chain can be used for ordinary applications without any problem. However, consult us for an application very sensitive to magnetism such as the production of electronic parts.



## Installation, Adjustment and Maintenance

### Installation of Sprockets

The installation accuracy of sprockets greatly affects the service life of equipment and conveyor chain. Even if they are accurately installed, vibration during operation, land subsidence, etc. may cause deviation. In such cases, the teeth of sprockets are worn laterally and/or the conveyor chain is damaged. Misalignment, parallel measurement and other checks must be conducted from time to time.

#### Levelness

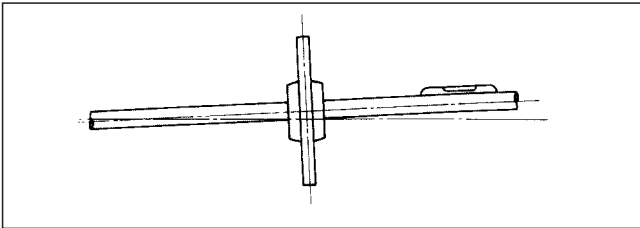

Using a level, adjust the levelness as specified below.

Flow conveyor :  $\frac{\pm 1.0\text{mm}}{1\text{m}}$  or less

Bucket conveyor :  $\frac{\pm 0.5\text{mm}}{1\text{m}}$  or less

Long pan conveyor :  $\frac{\pm 0.5\text{mm}}{1\text{m}}$  or less

Slat conveyor :  $\frac{\pm 0.5\text{mm}}{1\text{m}}$  or less

#### Deviation of sprocket from conveyor chain center line

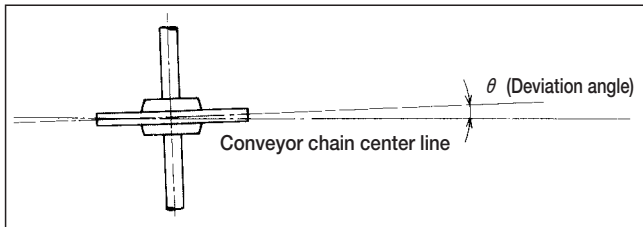

Adjust to eliminate deviation from the conveyor chain center line.

#### Misalignment of sprockets

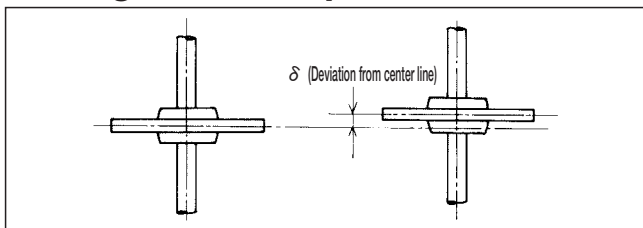

Adjust to align the driving and driven sprockets as specified below.

Flow conveyor :  $\delta = 1\text{mm}$  or less

Bucket conveyor :  $\delta = 2\text{mm}$  or less

Long pan conveyor :  $\delta = 1\text{mm}$  or less

Slat conveyor :  $\delta = 1\text{mm}$  or less

(3 mm or less for strong type chain 120H and 120Z or larger)

### Conveyor Chain Connection Procedure

As the general connection procedure for conveyor chain, take steps 1 through 4 below. For disconnection, reverse the steps.

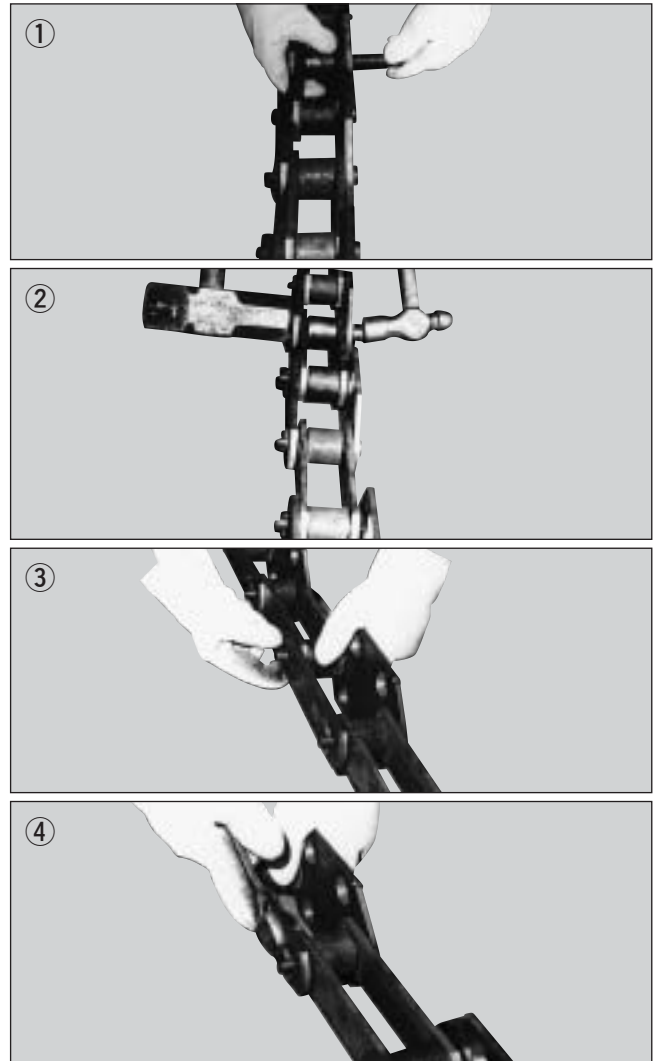

1. Pull out the pin from one end of the chain, and place the chain in alignment with the pin holes of the inner and outer plates. (Photo 1)
2. Insert the pin into the plate hole. (Photo 1)
3. Apply one hammer to the back of the plate on the other side, and insert the pin by hitting it with another hammer. (Photo 2)
4. Insert a T-pin into the pin hole, and bend it by a wrench etc. to secure it in position. (Photo 3 and 4)

#### (Cautions)

1. Confirm the feeding direction of the chain, the positions of attachments etc. before connecting.
2. When hammering in the pin, do not grind the pin to make the process easier. A ground pin will cause various troubles.
3. After completion of chain connection, confirm whether the chain can bend smoothly.

## Tension Adjustment of Conveyor Chain

Overly tight or sagged conveyor chain cannot be smoothly operated. Especially, an overly sagged chain rides over sprockets and interferes with the rail, etc. So, check chain condition at appropriate timing and adjust the chain for proper operation.

## Timing of Adjustment

At the beginning of operation, a chain causes initial elongation, and subsequently is elongated due to steady wear. Usually the components of a chain are hardened on the surface, and if the hardened layer is exhausted, elongation progresses rapidly. So, periodical checks are necessary.

### ● Check frequency for 8-hour per day operation

Within one week after start up of operation	Once daily
Within one month after start up of operation	Once weekly
One month after start up of operation	Twice monthly

This table shows a general case. In the case of continuous operation, operation in abrasive or corrosive environments, increase the check frequency.

## (Cautions)

- Also for a chain with tension automatically adjusted by counter weight take-up or spring take-up, confirm whether the tension device functions properly.
- When high-temperature articles are conveyed, be sure to adjust the take-up since the chain expands or contracts remarkably when the conveyor is started or stopped.

## Adjust Take-up by Two People

The take-up adjustment must be performed equally on both sides. So, one person is required to check the tension of chain, while the other carries out adjustment. For adjustment, alternate tension on both sides little by little. When chain is tensioned too tightly on one side only, accidents are caused. Be sure to position the chain at the centers of the teeth of the sprockets. When the chain is not positioned at the centers of teeth, adjust by tightening the side with a clearance between the sprocket and the chain, or loosen the side where the sprocket is in contact with the chain.

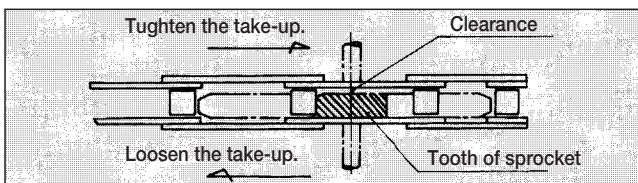

## Shorten the Chain Before Elongation Limit

The chain tension is adjusted by take-up. However, cut short the chain before the elongation comes close to the limit. An overly sagged chain causes troubles due to interference and contact.

## Check Point

Chains sag generally at one place. Therefore, confirm at first what point of the conveyor should be checked. Furthermore, ensure the safety of the area to be checked.

- With a horizontal conveyor, irrespective of top or bottom conveyance, the sagging is usually eliminated on the chain return side at a portion immediately after or downstream of the driving sprocket.
- With a straight gradient conveyor, the point where the sagging is eliminated depends on the gradient angle and the kind of conveyor, so refer to the instruction manual, etc.
- With an L-type or S-type conveyor, sagging is eliminated at the bend case.

## Tension Adjusting Degree

The degree of tension adjustment is determined with reference to the following conditions.

- The chain smoothly departs from the sprockets.
- Spaces are secured to keep the chain, attachments, pans, etc. from interfering with the rail and frames.
- Appropriate tension is given to prevent surging.

For example, for a horizontal continuous flow conveyor, adjust the sag depth to about  $\delta = L/10 \sim L/20$ .

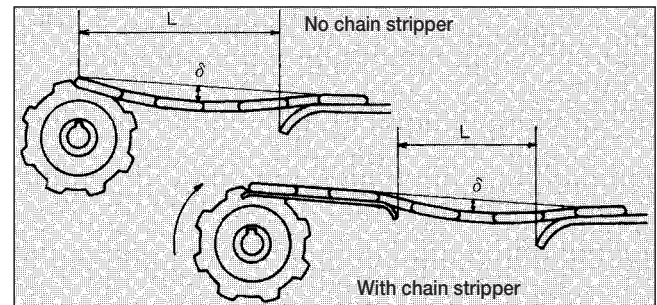

However, in the following cases, increase the adjusting frequency and set to  $\delta = L/15 \sim L/25$ .

- Intermittent operation of conveyors
- High-temperature loads
- High chain speed (25m/min or more)
- Heavy and/or large chains

With L-type continuous flow conveyor, adjust the tension to keep the chain directly visible from the inspection hole. The dimension is  $l \approx L/2$ .

Overly tight or sagged chains may cause accidents.

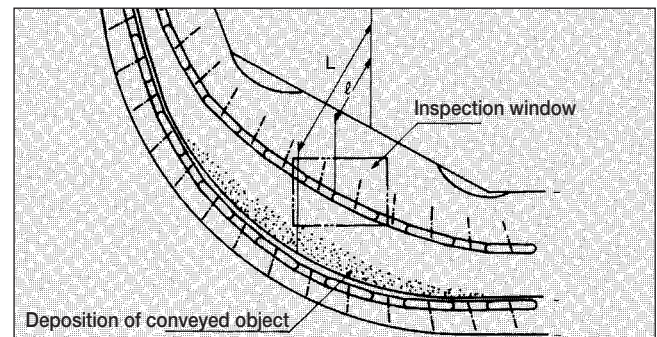

On the bottom of case, the conveyed articles are often deposited. So, periodically clean the inside, to secure space for slackening of chain.



## Lubrication

To extend the life of chain, periodical lubrication is important. However, in the following cases, avoid lubrication.

- 1) The chain is embedded in the loads (granular material, powder, etc.).
- 2) Granular material and powder deposit on the chain when carried by pan or apron conveyors. Here, lubrication works adversely.
- 3) The chain temperature becomes high.

### ● Lubricating oils and lubrication frequency

SAE	Temperature
SAE30	-10°C ~ 0°C
SAE40	0°C ~ 40°C

In general, lubricate once a week by applying or dripping.

### ● Automatic lubrication (oiling) device

We have various automatic lubrication (oiling) devices. Consult us if you are using chains in a setup where lubrication is difficult or if you plan to automate lubrication.

## Service Limits of Conveyor Chain and Sprockets

### ■ Service limit of conveyor chain

Conveyor chain performance gradually deteriorates by wear, corrosion, etc. depending on service conditions. The service limits of respective components are as stated below.

#### ● R-rollers and F-rollers

When the plates begin to contact the rail due to inside and outside wear of rollers.

#### ● S-rollers and M-rollers

When rollers are partially cracked or thickness becomes 40% of the original dimension due to wear.

#### ● Bushings

When the thickness of bushings become 40% of the original dimension due to wear.

#### ● Plates

Service limit of plate thickness :

When plate thickness decreases down to 1/3 of the original dimension due to mutual abrasion or contact with rollers.

Service limit of plate width :

When the plates directly slide on liners, the plates are worn in width, and strength is diminished.

In this case,  $X=1/8B$  is the service limit.

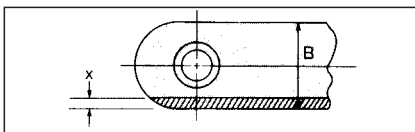

### ● Oblong pin-and bushing-fitted portions.

Pins and bushings are securely locked and pressed in plates. Long-term use or an overload loosens the portions where pins and bushings are fitted.

In this case, the plate holes become gradually oblong causing sudden progression of chain elongation. This is the service limit.

### ● Pitch elongation

A chain is bent when it engages with the sprockets or at corners, and the mutual wear between pins and bushings causes the entire length to be elongated. If the elongation becomes excessive, the engagement between the chain and the sprockets becomes less smooth and troubles occur.

Limit of chain elongation is 2 % of nominal pitch.

Measure chain elongation where tension is applied. Usually, measure from the head of one pin to the head of another, using a tape measure. Measure the length of four pitches or more.

### ● Fatigue limit

A chain receives varying loads repetitively every cycle. Long-term use causes plates, pins, etc. to reach their fatigue limit, resulting in cracking and then fracture. This is the service limit.

### ■ Service Limit of Sprocket

The wear of sprocket teeth is generally neglected. It is difficult to measure the wear loss and repair by padding is troublesome and diminishes operation efficiency. However, check teeth wear since it promotes wear elongation of the chain.

The wear limit is 3~5mm.

A sprocket reaching the service limit should be repaired according to a padding gauge or replaced entirely.

When a sprocket is replaced, pay attention to hub and key slot dimensions, etc.

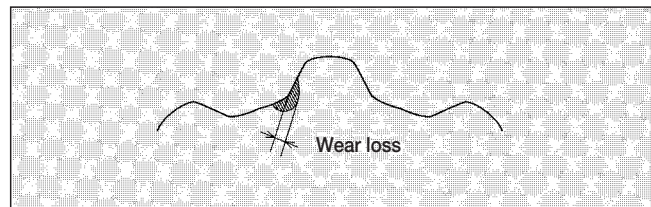

### ● Welding rod for padding

In general, select a welding rod of HV350 ~ HV600 in deposited metal hardness from JIS No.DF2B-B according to the degree of wear loss. However, note that if the hardness is about HV600, finishing is difficult.

When wear loss is extensive, use welding rod D4316 for underlaying.

### ● Teeth gauge for padding

Accurate finishing by a grinder using a teeth gauge is necessary when padding. Consult us for gauges.

# Inquiry Sheet (for Conveyor Chain)

When placing an order or inquiring, please fill in the following information.  
Use additional sheets when necessary.

Number of attached sheets:[    ]

	Date of inquiry:	Year	Month	Day
Name				
Department				
Company name				
Address 〒		TEL (    )	FAX (    )	
Machine concerned				
Manufacturer				
Chain currently used				
Manufacturer				

Conveyed material	Detail			
	Corrosiveness	With / without (    )		
	Abrasiveness	With / without (    )		
	Adhesion	With / without (    )		
	Temperature	Room temperature	°C	
	Dimensions·Mass		kg/pc.	
Service conditions	Service conditions	Place of installation	Indoor / outdoor (    )	
		Lubrication	Delivery: With / without (    )	
			During use: Impossible / Possible (Frequency    )	
			Kind: Manual / Drip / Other (    )	
		Motor used	AC / DC    kW×    rpm×    unit (s)	
		Chain pitch	mm	
	Average tensile strength	kN (kgf)		
	Chain	Roller type	S / M / R / F / Special (    )	
		Attachments	Installation intervals: Every    links (every    mm) A(    ) / K(    ) / G(    ) / SA(    ) / SK(    ) Special (    )	
		Mirror arranged attachments	Yes / No	
		Sliding parts	Rollers / Plates / Other (    )	
		Sprocket	Number of teeth of driving side	NT (PCD    mm)
Number of teeth of driven side			NT (PCD    mm) / Tail drum	
Shaft hole diameter	φ    Tolerance: H7 / H8 / Other (    )			
Hub form	Type ( A / B / C )    φ    ×    L			
Key groove	No / Yes Dimensions: ANSI: b    × t (    ) Parallel or Tapered			
Tooth Finish	Precision fusion cutting / Mechanical toothed wheel cutting / Induction hardening / Hard facing			

**Notes and machine layout**

Please indicate in detail the form of conveyor, loading and unloading methods, forms of attachments and rails, installation method on the return side, etc.  
Describe the maximum chain tension if it is known.  
Also indicate any problems of the machine and chain in current use.  
Inquiry sheet is also provided on our website below.  
<http://www.did-daido.co.jp>

## Glossary

Terms such as average tensile strength, minimum tensile strength, maximum allowable tension, and table of maximum horsepower ratings are important terms that indicate the performance of chains, and are often used in the text and table of chain dimensions in this catalog. Frequently used terms are explained below.

### 1. Average tensile strength

We conduct a test where a chain is pulled at both ends with a gradually increasing load until it breaks. The maximum load in this case is called the tensile strength of the chain. The average tensile strength is obtained by repeating this test. Since the average tensile strength is not a guaranteed value, it cannot be used for calculation of safety factor.

### 2. DID minimum tensile strength

This is our guaranteed tensile strength. Therefore, our chains all have tensile strengths exceeding this value. Use it for strength calculations such as to obtain safety factor. This value is decided on the conservative side, based on statistical processing of numerous tensile strength data and experience.

### 3. JIS minimum tensile strength

This is the strength value required for a chain conforming to JIS B 1801. Since our factory is authorized to use the JIS mark, the minimum tensile strengths of all DID chains exceed JIS minimum tensile strengths.

### 4. Maximum allowable tension

"Slow-speed selection" (see P121) is a method for selecting chains that uses the maximum allowable tension for the criterion of safety. The maximum allowable tension is decided on the more conservative side than the fatigue limit. Fatigue fracture\* will not occur if a load less than this value is repeatedly applied.

### 5. Table of maximum horsepower ratings

A chain is usually selected according to the "General selection" method (see P120) which uses the maximum horsepower rating for the criterion of safety. As shown on P120, the maximum horsepower rating shows the power which can be transmitted when the chain is operated under an ideal condition. The maximum horsepower ratings were obtained by actually operating chains in a test facility under good lubrication condition without vibration or shock.

## International System of Units (SI)

The international system of units has been in use since Oct. 1, 1999. The units in our catalogue include SI units and old units. Use the values in old units as reference.

### SI unit

	<b>SI Indication</b>	<b>SI Conversion</b>
Weight	Kg (kilogram)	
Power	N (newton)	1kN=1000N (kilonewton)
Torque moment	N·m (newtonmeter)	
Stress (pressure)	Pa (pascal)	$1\text{Pa} = \frac{1}{1,000,000} \text{N/mm}^2$ (pascal)  $= \frac{1}{10,000} \text{N/cm}^2$  1MPa=1000kPa (megapascal) 1kPa =1000Pa (kilopascal) 1hPa =100Pa (hectopascal)
Work energy	J (joule)	1N·m=1J (joule)
Work rate	S (second)	1W=1J/s=1N·m/s (watt)

### SI Calculations Using SI Units

1. Relation of torque, transmission power and rpm

$$T = \frac{1000 \times P}{2 \pi n_s} = \frac{60000 \times P}{2 \pi n_m}$$

T : Torque (N·m)  
 P : Transmission power (kW)  
 n<sub>s</sub> : rpm (s<sup>-1</sup>)  
 n<sub>m</sub> : rpm (min<sup>-1</sup>)

2. Relation of required power, power and speed

$$P = \frac{F \times V}{1000 \times \eta}$$

P : Required power (kW)  
 F : Power (N)  
 V : Speed (m/s)  
 η : Efficiency

3. Relation of rotating unit break torque and downtime

$$T = \frac{I \times 2 \pi n_s}{t} = \frac{I \times 2 \pi n_m}{60t}$$

T : Break torque (N·m)  
 I : Inertia moment (kg·m<sup>2</sup>)  
 n<sub>s</sub> : rpm (s<sup>-1</sup>)  
 n<sub>m</sub> : rpm (min<sup>-1</sup>)  
 t : Downtime (s)

4. Relation of weight, speed and energy

$$E = \frac{1}{2} \times m \times V^2$$

E : Motion energy (J)  
 m : Weight (kg)  
 V : Speed (m/s)



ویرا پرداز آروین پاسارگاد

با مدیریت خانم مهندس احمدی



جهت مشاوره

با کارشناسان فنی

با ما در ارتباط باشید



021 - 91001377



0935 125 90 98