



ویرا پرداز آروین پاسارگاد

با مدیریت خانم مهندس احمدی



جهت مشاوره

با کارشناسان فنی

با ما در ارتباط باشید



021 - 91001377



0935 125 90 98

FYH[®]

MOUNTED BEARING UNITS













NIPPON PILLOW BLOCK CO., LTD.

CAT.NO.3320

FYH[®]



Mounted Bearing Units (contents)

BALL BEARING UNITS	Technical Section	Technical Section	
	Pillow Block Units		
	4-Bolt Flange Units		
	Oval Flange Units		
	4-Bolt Flange Cartridge Units		
	Stamped Steel Flange Units		
	Take-Up Units		
	Cartridge Units		
	Hanger Units		
	Ball Bearing Inserts		
	Parts and Accessories	Parts and Accessories	
	SPHERICAL ROLLER BEARING UNITS	Technical Section	Technical Section
		Spherical Roller Bearing Units	
Appendix Table		Appendix Table	

BALL BEARING UNITS

Technical Section

1 Structure and Features

1.1 Structure	5
1.2 Features	5

2 Selection Guide

2.1 Selection Guide	8
2.2 High / Low Temperature Series	10
2.3 Corrosion Resistant Series	12
2.4 Air Handling Series	13
2.5 Dust Resistant Units	15

3 Models

3.1 Model List	18
3.2 Models and Features	20

4 Rating Life of Bearings

4.1 Basic Rating Life and Basic Load Rating ..	33
4.2 Calculation of Rating Life	33
4.3 Grease Life	35

5 Bearing Load

5.1 Loads Applied to Bearings	36
5.2 Distribution of Bearing Load	38
5.3 Dynamic Equivalent Load	38
5.4 Basic Static Load Rating and Static Equivalent Load	39
5.5 Example of Applied Calculation	40

6 Allowable Rotating Speed

6.1 Allowable Rotating Speed	46
6.2 Rotational Speed Adjustment Due to Shaft Fit	47

7 Operating Temperature and Bearing Specifications

7.1 Operating Temperature Range	47
7.2 Operating Temperature and Internal Clearance of Bearings	47

8 Strength of Housings

8.1 Strength of Cast Iron Housings	48
8.2 Strength of Ductile Cast Iron Housings ...	48
8.3 Strength of Stamped Steel Housings	54
8.4 Strength of Stainless Steel Housings	54
8.5 Strength of Die-cast Housings	54
8.6 Static Rupture Strength of Plastic Housings ..	55

9 Design of Shaft and Base

9.1 Design of Shaft	56
9.2 Mounting Base Design	59
9.3 Dowel Pins for Accurate Unit Mounting ...	60

10 Nomenclature

11 Accuracy and Internal Clearance

11.1 Accuracy of Bearings	63
11.2 Accuracy of Housings	65
11.3 Internal Bearing Clearance	67

12 Materials

12.1 Bearing Material	68
12.2 Housing Material	68
12.3 Materials of Parts and Accessories	69

13 Performance

13.1 Bearing Friction Torque	70
13.2 Bearing Temperature Increase	70

14 Handling

14.1 Installation	71
14.2 Test Run Inspection	75
14.3 Periodic Inspection	75
14.4 Supply of Grease	76
14.5 Replacing Bearings	78

Unit Dimensional Table

15 Dimensional Tables for

Ball Bearing Units 79

1 Pillow Block Units

Pillow Block Units	82
Thick Pillow Block Units	102
Tapped-Base Pillow Block Units	106
High-Base Pillow Block Units	114
Narrow Inner Ring Bearing Pillow Block Units ...	116
Light Pillow Block Units	120
Compact Pillow Block Units	122
Corrosion Resistant Series Pillow Block Units ...	124
Stamped Steel Pillow Block Units	136

2 4-Bolt Flange Units

4-Bolt Flange Units	138
Square Piloted 4-Bolt Flange Units	160
Narrow Inner Ring Bearing 4-Bolt Flange Units ...	164
Corrosion Resistant Series 4-Bolt Flange Units ...	166

3 Oval Flange Units

2-Bolt Flange Units	174
Adjustable 2-Bolt Flange Units	194
3-Bolt Flange Units	196
Narrow Inner Ring Bearing 2-Bolt Flange Units ...	198
Light 3-Bolt Flange Units	200
Light 2-Bolt Flange Units	202
Compact 2-Bolt Flange Units	204
Corrosion Resistant Series 2-Bolt Flange Units ...	206
Corrosion Resistant Series 3-Bolt Flange Units ...	216

4 4-Bolt Flange Cartridge Units

4-Bolt Flange Cartridge Units	218
Narrow Inner Ring Bearing 4-Bolt Flange Cartridge Units	232
Corrosion Resistant Series 4-Bolt Flange Cartridge Units	234

5 Stamped Steel Flange Units

Stamped Steel 3-Bolt Flange Cartridge Units ...	236
Stamped Steel 2-Bolt Flange Units	238

6 Take-Up Units

Take-Up Units	240
Narrow Slot Take-Up Units	260
Corrosion Resistant Series Take-Up Units	262
Section Steel Frame Take-Up Units	266
Channel Steel Frame Take-Up Units	268
Steel Plate Frame Take-Up Units	274

7 Other Units

Cartridge Units	278
Hanger Units	284

8 Ball Bearing Inserts

Cylindrical bore (with set screws)	286
Stainless steel series Cylindrical bore (with set screws)	294
Cylindrical bore (with eccentric locking collar) ...	296
Cylindrical bore (with concentric locking collar) ...	302
Cylindrical bore (with concentric locking collar) Cylindrical O. D.	304
Tapered bore (with adapter)	306
Cylindrical bore (with set screws) Cylindrical O. D.	312
Cylindrical bore (with eccentric locking collar) Cylindrical O. D.	314
Cylindrical bore	316

9 Bearing Adapter 318

Parts and Accessories

16 Parts and Accessories

16.1 Part No. of Steel Plate Covers.....	322
16.2 Part No. of Cast Iron Covers.....	323

SPHERICAL ROLLER BEARING UNITS

Spherical Roller Bearing Units (contents) 325

1 Structure and Features

1.1 Structure 326

1.2 Features 326

2 Models

2.1 Model List 329

2.2 Models and Features 330

3 Nomenclature 332

4 Engineering Information 332

5 Installation Guide

5.1 Precautions 334

5.2 Preparation 334

5.3 Installation 335

5.4 Lubrication 336

6 Dimensional Tables for Spherical Roller Bearing Units 338

Appendix Table

Appendix Table (contents) 357

1 Simplified Chart of Ball Bearing Unit Combinations 358

2 Tightening Torques of Housings and Cast Iron Cover Mounting Bolts 360

3 Tightening Torques of Inner Rings and Eccentric Locking Collar Set Screws 360

4 Tightening Torques of Adapter Lock Nuts (reference) 361

5 Machining Dimensions of Holes of Housing Dowel Pins 362

6 Dimensional Tolerances of Shafts 364

7 Dimensional Tolerances of Housing Bores 366

8 Basic Tolerance Values 368

9 SI Unit Conversion Charts 369

10 Inch-meter Conversion Chart 370

11 Hardness Conversion Chart 371

12 Viscosity Conversion Chart 372

13 Mechanical Properties of Metal Materials (reference) 373

14 Hexagon Socket Head Cap Screws (abstract from JIS B 1176) 374

15 Hexagon Head Bolts (abstract from JIS B 1180) 376

16 Hexagon Head Nuts (abstract from JIS B 1181) 378

17 Ball Bearing Units Interchange Guide 379

18 Spherical Roller Bearing Units Interchange Guide 381

★The contents of this catalogue are subject to change without prior notice. Every possible effort has been made to ensure that the data listed in this catalog is correct. However, we can not assume responsibility for any errors or omissions.

1 Structure and Features

FYH Ball Bearing Units are manufactured to exacting standards comprising of grease sealed deep groove ball bearings and housings in various forms.

Self-aligning units allow for easy installation and are supplied with grease fittings in order to facilitate quick and convenient re-lubrication.

1.1 Structure

FYH Ball Bearing Units are constructed of high carbon chromium bearing steel and have precision honed raceways and riveted steel cages (Fig. 1.1).

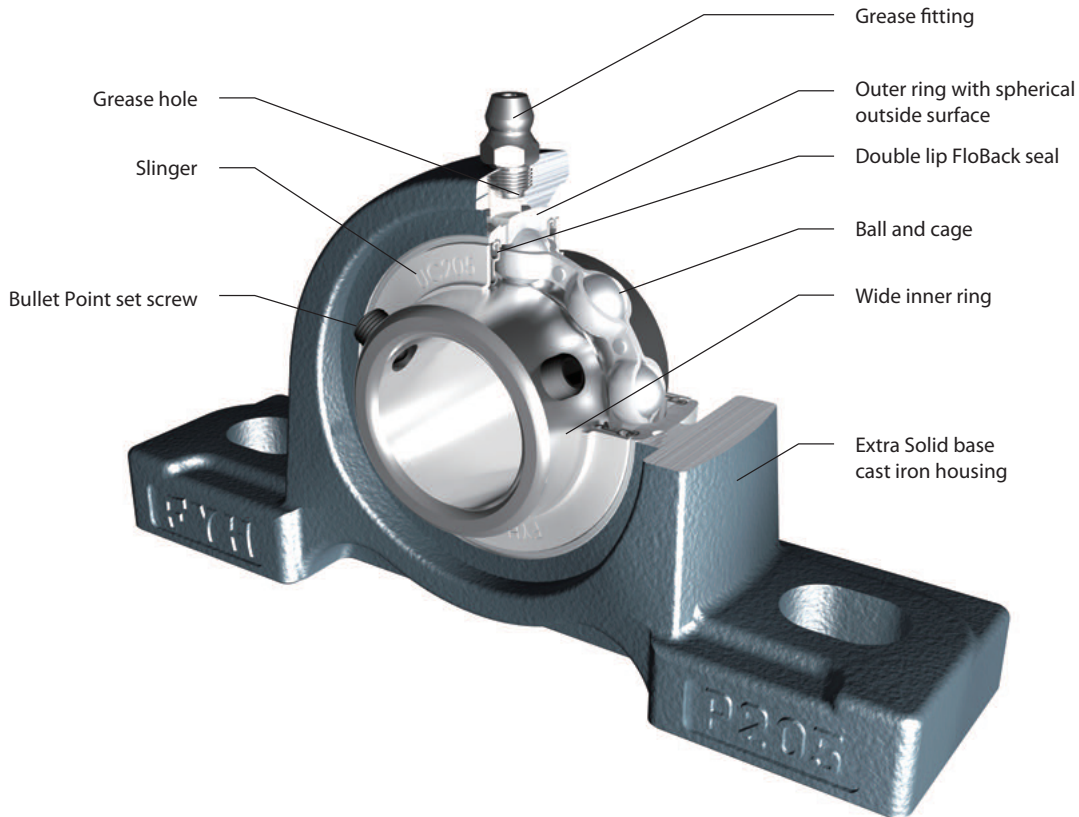

Fig. 1.1 Structure of ball bearing units (representative example)

1.2 Features

FYH Ball Bearing Units have many features and are available in various models. A wide selection of mounted units is offered to fit virtually any application.

1 Supreme load capacity and accuracy

FYH Ball Bearing Units feature an internal structure identical to single row deep groove ball bearings and can bear significant radial load, as well as a great deal of axial load in both directions. The hardened steel balls exhibit a high degree of "roundness" and the races are highly polished to accommodate a smooth ride at a wide range of speeds.

2 Rational self-aligning mechanism and optimal fit

FYH Ball Bearing Units have the special ability to self-align inside the housing because of the spherical shape of the outer diameter of the bearing insert and the concave shape of the inner diameter of the housing into which it fits.

This design allows the bearing unit to self-adjust for shaft deviation and reduce abnormal bearing load. Therefore, the original rated life of the bearing can be guaranteed. Since the spherical outside surface of the bearing is precision ground and the spherical bore of the housing is machined by a boring machine with great accuracy, optimal fitting of the bearing and the housing can be obtained, as well as superior aligning performance. The allowable aligning angle of standard ball bearing units is 3°, while units with covers is 1°.

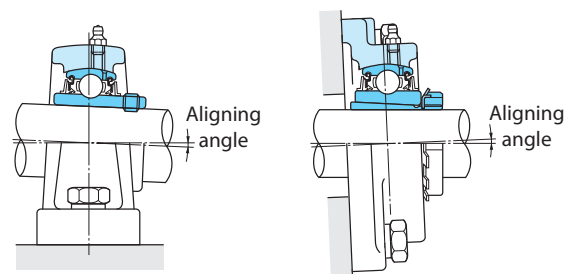

Fig. 1.2 Allowable aligning angle of ball bearing units

3 Superior sealing performance

FYH Ball Bearing Units efficiently prevent grease from leaking out of the interior of the bearing, and perform extremely well at keeping contaminants, such as dust and water, from entering. This is achieved by installing the seal to the outer ring of the bearing and installing the slinger to the inner ring of the bearing.

The FloBack seal to be used in the standard FYH Ball Bearing units will contribute to the long life of the bearing. It consists of a double-lip seal which is stamped into place in the outer ring of the bearing to reduce the possibility of being pushed out from over-lubrication. The first seal makes contact with the inside of the slinger which provides the first line of defense against contamination. The next seal makes contact with the inner ring to provide another level of contamination resistance. An additional level of protection exists in the extra non-contact inward facing lip which allows grease to flow back towards the balls and raceways during operation thereby improving lubrication performance and extending bearing life.

Allowable rotating speed is the same as the previous seal design while providing more than four times better protection.

4 Simple lubrication

FYH Ball Bearing Units are tapped to accept a grease fitting which is also supplied with every mounted unit. Bearings are pre-lubricated at the factory and do not require additional grease upon installation. When operating in excessively moist, dusty, or hot environments, it is recommended that grease be supplied at regular intervals. If appropriately maintained, the rated life of the bearing can be extended.

FYH Lithium Bearing Grease to be sealed in early bearing grease use are manufactured to accommodate a wide range of operating conditions.

FYH Lithium Bearing Grease can be mixed with former FYH Bearing grease as it will improve performance, corrosion resistance, loading capability, and promote longer bearing life.

The grease fittings that are supplied with FYH mounted units include 1/4-28 for smaller units and 1/8 PT for larger units. Additional styles are available upon request. FYH Lithium Bearing Grease is also available in automatic lubricators.



Fig. 1.3 Sealing mechanism of ball bearing units



5 Highly rigid and rugged cast iron housings

FYH Ball Bearing Unit housings are designed so that they are optimized for reduction of deformation due to centralization of stress and load. Only the best material is selected to be cast by a highly advanced technique or press working technique, depending on the housing. Since any abnormal load on the bearing is eliminated by the housing, the life of the bearing can be extended. A Granular material baking finish coating (powder coating) helps resist corrosion and protect the surface of the housing for an extended period of time.

FYH original solid base pillow block housings seat better and produce a more stable mounting configuration that significantly reduces vibration.

The support ribs have been eliminated to make more room for mounting bolts and washers, yet these housings are more than 30% stronger than before while also reducing housing weight. The new housing downward destruction strength means that the inserts break before the housings.

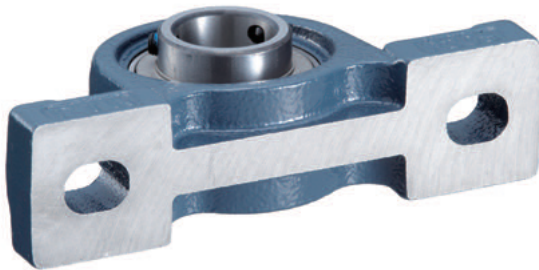

6 Simple installation and handling

FYH Ball Bearing Units interchange with many different models and can be bolted to machinery without any modification. The exact amount of clearance is allowed between the bore and the shaft to allow a perfect fit. Therefore, FYH Ball Bearing Units do not require any additional lubrication or seal installation. As a result, handling and downtime can be drastically reduced. Four different locking mechanisms are available:

- (1) Set Screw
- (2) Eccentric Locking Collar
- (3) Tapered Adapter
- (4) Concentric Collar

Mounting the bearing to the shaft can be executed easily and securely by adopting any of these methods.

7 Series and models

FYH Ball Bearing Units are available in various series and models. Reliability of machinery or equipment, used together with these units, can be improved by selecting and using units optimal for the application and operating conditions.



- High / Low Temperature Series



- Corrosion Resistant Series

Stainless Units
Plastic Units
Nickel plated Units



- Air Handling Series

S3 & S5 Bearing Units
NU-LOC Units



- Dust Resistant Units

Triple lip seal inserts
Felt seal inserts



- Dirt Resistant Units

Tight Triple lip seal inserts
Units with Covers

- Tougher casting Series
Ductile iron housing

- Compact and lightweight Series
Small die cast Units
Lightweight casting Units
Stamped Units

2 Selection Guide

2.1 Selection Guide

1. Select the housing style that best suits your application.

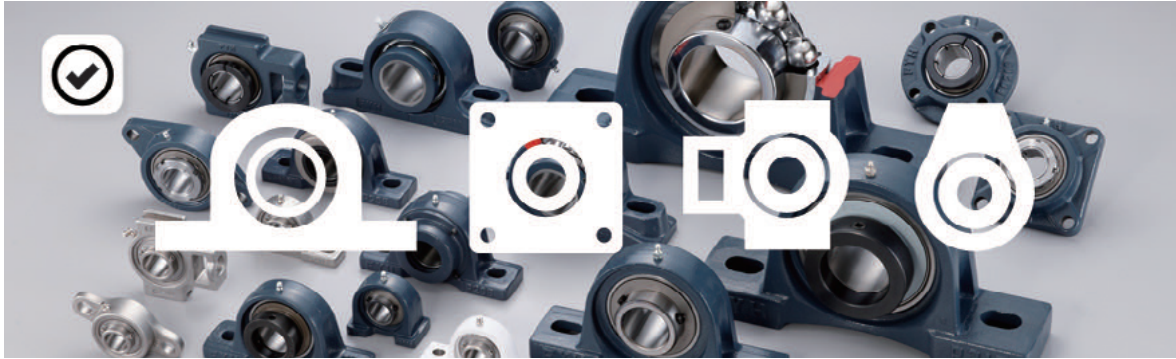

P - PILLOW BLOCK **PA** - TAPPED-BASE **PH** - HIGH-BASE **LP** - LIGHT **IP** - THICK **PP** - STAMPED STEEL
F - 4-BOLT FLANGE **FS** - SQUARE PILOTED
FL - 2-BOLT FLANGE **LF** - LIGHT **PFL** - STAMPED STEEL **FA** - ADJUSTABLE
FB - 3-BOLT FLANGE
FC - 4-BOLT FLANGE CARTRIDGE
T - TAKE-UP
C - CARTRIDGE
H - HANGER

2. Select the shaft size and duty that is needed for your application.

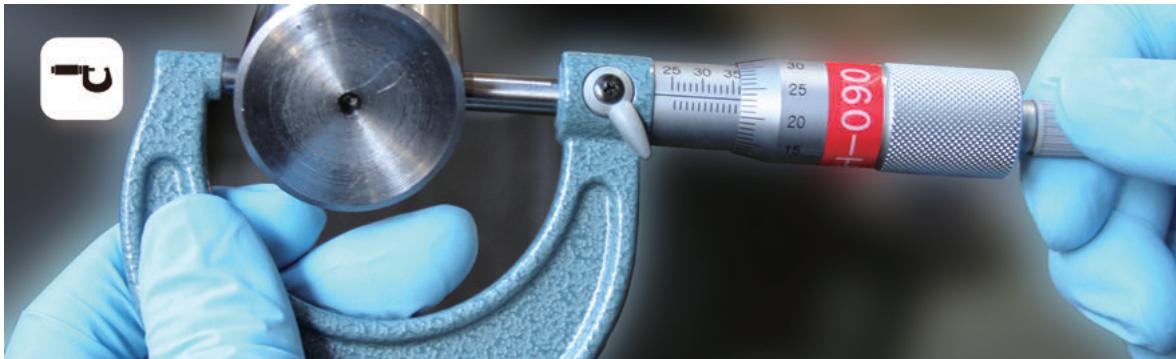

SU - FROM 10 MM TO 30 MM BORE
SA & SB - FROM 12 MM & 1/2" TO 40 MM & 1-9/16" BORE
UC - FROM 12 MM & 1/2" TO 140 MM BORE
NA - FROM 12 MM & 1/2" TO 75 MM & 3" BORE
NC - FROM 20 MM & 3/4" TO 60 MM & 2-7/16" BORE
UK - FROM 20 MM & 3/4" TO 120 MM BORE

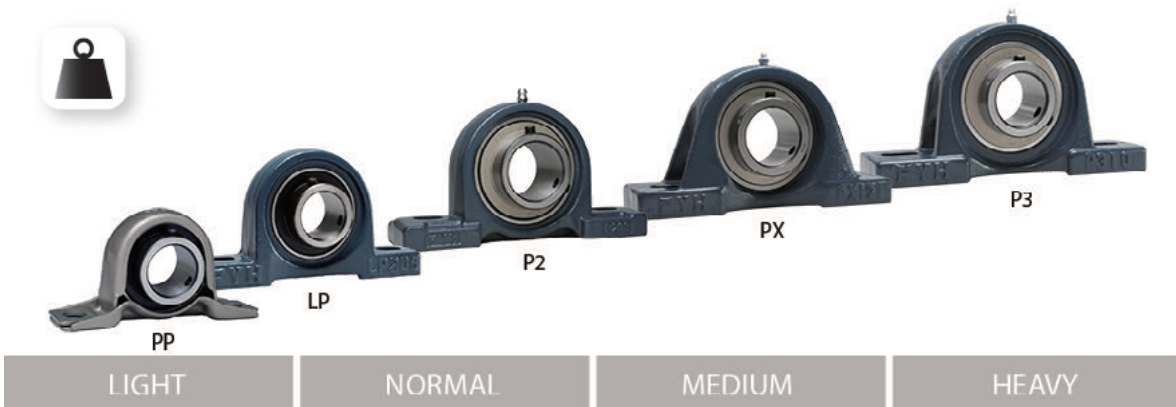

3. Do you need to customize the bearing for your application? Select STANDARD as the default.



TEMP - **D2K2** -58°F TO 248°F (-50°C TO 120°C), **D1K2** -40°F TO 356°F (-40°C TO 180°C), **D9K2** -4°F TO 446°F (-20°C TO 230°C)
WASH DOWN - STAINLESS STEEL UNITS, PLASTIC HOUSING UNITS,
AIR HANDLING - **S3** AIR HANDLING FIT UNITS, **S5** NON CONTACT SEAL
DUST - **L3** TRIPLE LIP SEAL, COVERS
DIRT - **LT3** TIGHT TRIPLE LIP SEAL, COVERS

4. Select the locking style type for your insert.



UC - SETSCREW LOCK
NA - ECCENTRIC COLLAR LOCK
NC - CONCENTRIC COLLAR LOCK
UK - ADAPTER SLEEVE LOCK

5. YOUR UNIT



Selection application is available for download in the mobile device.





TEMP

2.2 High / Low Temperature Series

(suffix codes - High temperature: D1K2 & D9K2, Low temperature: D2K2)

For applications that require bearing units to be used at a higher or lower temperature range than our standard models FYH offers several options. For high temperature units that require lubrication please specify D1K2 as a suffix to the standard part number. For high temperature units that do not require lubrication specify D9K2.

The D9K2 insert uses a fluoro-grease that allows for excellent heat resistance and operation with minimal maintenance.

Specifications for the high temperature and low temperature units are shown in **Table 2.1**.



Table 2.1 Specifications of High / Low Temperature Series

Specifications of High / Low Temperature Series							
Category	Suffix code	Operating temperature range		Grease	Seal rubber material	Bearing internal clearance	
		(°C)	(°F)			UC type	UK type
Standard	-	-20 to 100	-4 to 212	FYH Lithium Bearing Grease (lithium complex)	Nitrile	CN	C3
Cold resistant	D2K2	-50 to 120	-58 to 248	SH33M (lithium)	Silicone	CN	C3
Heat resistant	D1K2	-40 to 180	-40 to 356	U-RET EDM-1 (diurea)	Silicone	C4	C5
Heat resistant	D9K2	-20 to 230	-4 to 446	Demnum L-200 (fluorinated grease)	Silicone	C4	C5

Specifications of Extreme High Temperature Series							
Category	Suffix code	Operating temperature range		Grease	Seal rubber material	Bearing internal clearance	
		(°C)	(°F)			UC type	UK type
Heat resistant	D9P4S6Y2	-20 to 260	-4 to 500	Demnum L-200 (fluorinated grease)	-	C4	-
Extreme heat resistant	S6Y3	300 to 450	572 to 842	Solid graphite lubricant	-	Special	-

Table 2.2 Grease Schedule of Ball Bearing Units

Grease schedule of ball bearing units						
Operating temperature °C		Grease Intervals			Bearing used	Grease supplied
Over	Incl.	Substantially clean	Excessive dust	Excessive dust and moisture		
	50	(3 months) not necessary	(2 months) 1 year	(1 month) 4 months	(Low temperature D2K2) ¹⁾ Standard bearing	SH33M
50 70	70 100	1 year 6 months	4 months 2 months	1 month 2 weeks		FYH Lithium - Bearing Grease
100 120 150	120 150 180	2 months 2 weeks 1 week	2 weeks 5 days 2 days	5 days 2 days 1 day	High temperature D1K2	U-RET EDM-1

Note 1) Greasing intervals in parentheses are applicable to low temperature grease (D2K2).
 Remark Greasing intervals shown in this table are applicable to a unit operated for 8 to 10 hours per day.
 If the time of operation is greater than this range, then a more frequent greasing interval must be specified.
 For example, if the unit is operated 16 to 20 hours per day, then the greasing interval must be twice as frequent.



2.2.1 Rotational speed adjustment due to shaft fit

A marginal degree of clearance is typically used to facilitate easy installation of a bearing to a shaft.

The amount of clearance between the bearing and shaft must be factored in to determine the maximum allowable rotational speed, and as rotational speed is increased, the amount of clearance must be decreased.

Table 2.3 shows the factor that must be used to correct the allowable rotational speed. The maximum rotational speed is determined by multiplying the speed found in **Table 6.1** by the factors below.

Table 2.3 Fitting factor of ball bearing units f_c (recommended)

Type of ball bearing units	Fitting factor f_c					
	Shaft tolerance range class					
	h5, j5	j6	h6	h7	h8	h9
Heat resistant type (Suffix code: D1K2)	-	-	-	1	1	0.7
Cold resistant type (Suffix code: D2K2)	-	-	-	1	1	0.7

2.2.2 Correction of basic load rating due to temperature

If a ball bearing unit is used at a relatively high temperature the physical composition of the bearing material is changed leading to decreased hardness. This decreased hardness leads to the basic dynamic load rating being reduced. Once the structure of the bearing material has been changed, it will remain this way for the life of the unit, even when it returns to room temperature.

When using a ball bearing unit at 150 °C or more, the basic load rating must be corrected by multiplying the basic dynamic load rating shown in the dimensional table by the temperature factor shown in **Table 2.4**.

Table 2.4 Temperature factor

Bearing temperature, °C	125	150	175	200	250
Temperature factor	1	1	0.95	0.9	0.75

2.2.3 Operating temperature range

The operating temperature of a ball bearing unit depends on the type of grease, the material of the seal, and the internal clearance of the bearing. FYH Ball Bearing Units are available in high temperature (D1K2, D9K2) and low temperature (D2K2) series, in addition to the standard models, to allow selection of the correct bearing for your operational temperature (see **Table 2.1**). The correct unit must be chosen for the desired temperature range, and it is equally important to use the appropriate grease according to the specified schedule.

2.2.4 Operating temperature and internal clearance of bearings

When bearings are operated in a high ambient temperature environment, or when the operating temperature is high because of rotational speed, differential expansion rates occur within the bearing components. This causes higher friction, grease breakdown, and eventual seizure.

If the temperature difference between the inner and outer ring is known, or can be approximated, then the following **Formula (2.1)** may be applied.

Under these conditions, decrease in the internal clearance must be calculated, and the internal clearance of bearing needs to be selected properly.

$$S_{t1} = \alpha \cdot D_e \cdot \Delta t \dots\dots\dots (2.1)$$

Whereas,

S_{t1} : Decrease in the internal clearance of bearings depending on the difference in the temperatures of the bearing inner ring and the bearing outer ring can be found by formula, mm

α : Line expansion factor of bearing steel, 12.5×10^{-6}

D_e : Raceway dia. of bearing outer ring, mm

Diameter series 2, X $D_e \approx 0.92 D$

Diameter series 3 $D_e \approx 0.9 D$

D : Nominal bearing outer dia., mm

Δt : Difference in temperatures of bearing inner ring and outer ring, °C

If a ball bearing unit is used in a high temperature environment, an abnormal load will result due to thermal expansion of the shaft. This must be compensated for by allowing free movement of one side of the shaft. (See "9 Design of shaft and base")

CERAMIC BALL UNITS



Y2: Ceramic balls with stainless units

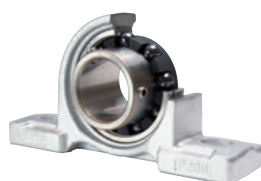

Y3: Ceramic balls with a solid self-lubricating lubricant

Ceramic Ball Units features

- Reduced maintenance costs
- Green bearings
- Independent operation
- Low friction
- High stress resistance
- Non-conductive





2.3 Corrosion Resistant Series

The Corrosion Resistant Series is available in a wide array of sizes and styles, and units may be customized with a number of different specialized options to accommodate virtually any application. Federal compliance can be assured with FYH Bearing Units.

WASH DOWN



S6 STAINLESS INSERT



RINGS	Stainless steel (SUS 440C equivalent)
BALLS	SUS 440C
CAGE	SUS304
GREASE	H1 FOOD GRADE (FDA /USDA)
SEALS	NBR
SLINGER	SUS304
ANTI-ROTATION PIN	SUS304
SET SCREWS	SUS304
AVAILABLE SIZES	201X - 203X , 204 - 212
CLEARANCE	C3



S7 PLATED INSERT



RINGS	SUJ2 + (zinc plated + trivalent chromate treatment)
BALLS	SUJ2
CAGE	NYLON
GREASE	H1 FOOD GRADE (FDA /USDA)
SEALS	NBR
SLINGER	SPCC + (zinc plated + trivalent chromate treatment)
ANTI-ROTATION PIN	SUS304
SET SCREWS	SCM435 + (zinc plated + trivalent chromate treatment)
AVAILABLE SIZES	204 - 210
CLEARANCE	C3



VP VF VFL VPA
Thermoplastic Housings



Thermoplastic Polyester

H1, H9
Stainless Steel Housings



Lost Wax Casting
(SUS304 or 316 equivalent)

Z5
Nickel Plated Housings



Cast Iron + Nickel Plating





AIR HANDLING

2.4 Air Handling Series

Units for HVAC and air handling (suffix code: S3, S5)

Ball bearing units for blowers must meet the demands of high speed rotation, low vibration, low noise, and decreased temperature output.

To meet these performance needs FYH produces the S3 and S5 series with tighter bore tolerances.

S5 uses non-contact seals as well as an improved machining accuracy to cut down on heat, noise, and vibration.



Table 2.5 Specifications of air handling units



Air Handling Fit	
100% Noise Check	
P11	The anti-rotation pin



Air Handling Fit	
100% Noise Check	
P11	The anti-rotation pin
C2	Internal bearing clearance is defined as the allowable space between the rolling elements and the raceways. C2 is smaller clearance than the standard, and it reduces the noise and vibration in high speed applications.
P18	P18 is the suffix code that designates smaller bore tolerance which allows for a tighter fit with the shaft. This, in turn, reduces vibration and noise and dramatically increases bearing life.
K3	Non contact lip seal is available for the lighter torque.

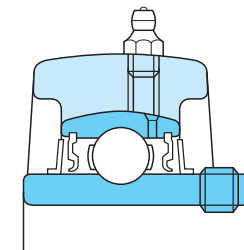

2.4.1 Features of the air handling units

The air handling unit is manufactured with original fitting called the air handling fit which exists in the middle with fitting "H" which can be assembled more easily than a standard fit "J." In addition, "J" fit the standard is fit that there is not the need for the anti-rotation pin, but can be very secure in high speed applications by adding the anti-rotation pin.

S3 and S5 bearings are sound tested in order to make sure the noise level is low enough to be suitable for high speed applications such as blowers.

2.4.2 Feature of air handling S5 specification for blowers

(1) Dimensional tolerances of shafts for blowers (used with set screw bearings)

For bearings used in blowers (suffix code: S5), a C2 internal ball clearance is recommended to reduce vibration and noise during operation.

Therefore, the shaft tolerance classes shown in **Table 2.6** are recommended for bearings with set screws.

Refer to ("11.3 Internal bearing clearance") Details of the internal C2 ball clearance.

Table 2.6 Dimensional tolerance of shaft used for bearings (set screw type) for blowers

unit: μm

Shaft dia. (mm)		Dimensional tolerance of shaft			
		h5		j5	
Over	Incl.	Max.	Min.	Max.	Min.
10	18	0	- 8	+5	- 3
18	30	0	- 9	+5	- 4
30	50	0	-11	+6	- 5
50	80	0	-13	+6	- 7
80	120	0	-15	+6	- 9
120	180	0	-18	+7	-11

(2) Tolerance of inner rings of S5 specification

P18 is the suffix code that designates smaller bore tolerance which allows for a tighter fit with the shaft. This, in turn, reduces vibration and noise and dramatically increases bearing life.

Table 2.7 Tolerance and tolerance values of inner rings of P18 suffix (unit: μm)

Nominal bearing bore dia. d (mm)		Variation of tolerance of average bore dia. in plane Δd_{mp}		Unequal bore dia. in plane V_{dsp}	Radial runout of inner ring K_{ia}
Over	Incl.	Max.	Min.	Max.	Max.
10	18	+13	0	6	7
18	31.75	+13	0	6	8
31.75	50.8	+13	0	10	10
50.8	80	+15	0	10	10

Table 2.8 Tolerance and tolerance values of inner rings of ISO standard (unit: μm)

Nominal bearing bore dia. d (mm)		Variation of tolerance of average bore dia. in plane Δd_{mp}		Unequal bore dia. in plane V_{dsp}	Radial runout of inner ring K_{ia}
Over	Incl.	Max.	Min.	Max.	Max.
10	18	+15	0	10	15
18	31.75	+18	0	12	18
31.75	50.8	+21	0	14	20
50.8	80	+24	0	16	25



DUST



DIRT

2.5 Dust Resistant Units

The FYH Dust Resistant Units consists of a variety of supplemental sealing options that function extremely well in the exclusion of foreign matter. These options can work well by themselves or in combination with each other. From food processing and agricultural to wash-down and mining and aggregate, the FYH Dust Resistant Units can stand up to the toughest contamination challenges.

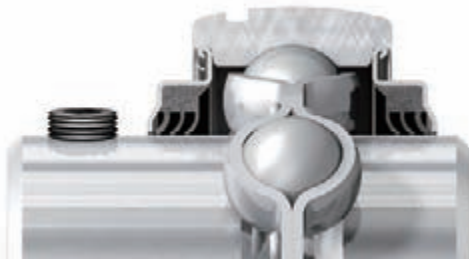

Triple-Lip Seals (suffix code: L3)

The L3 seal consists of a stamped steel shield with a molded NBR try-ply seal affixed to the inner portion of the shield, all of which is attached to the outer ring of the bearing. The triple-lip seal is excellent for resisting all types of contamination and is appropriate for low to moderate speeds.

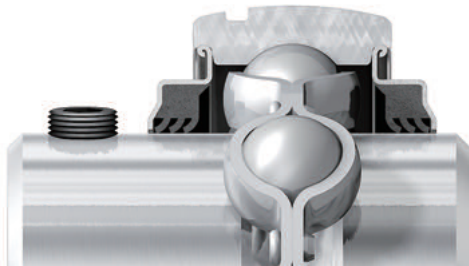

Tight Triple-Lip Seals (suffix code: LT3)

The LT3 Triple-Lip seal fits tighter than the standard L3 seal. The rotating torque of the LT3 seal is approximately double that of the standard L3 seal, and it is appropriate where contamination or moisture are very high and rotating speeds are very low.



Stamped steel and cast iron covers are available in open or closed versions in a complete range of sizes. They are easy to install and they offer great resistance to wet and dry contaminants, and shocks and heats. Covers protect the entire bearing insert from contamination and they also help to provide a safer working environment.

Stamped Steel Open Covers



Cast Iron Open Covers

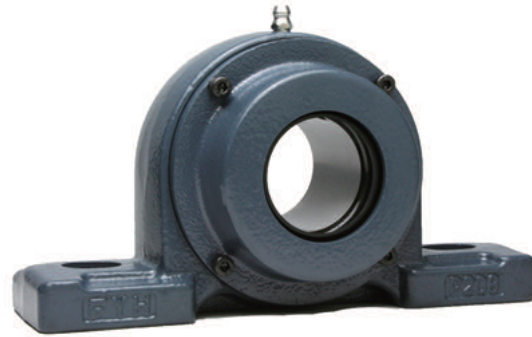

BACKSIDE GUARD



The nitrile rubber shields can be mounted on the backside of two and four bolt flange units and the equipment it is bolted onto. The backside guard protects your bearings from dust and moisture and help lead to longer bearing life in applications where this can be an issue.

The nitrile rubber on the steel plate come without a drain slot and is designed for dust protection. Some applications where this product could be used include: aggregate applications, fertilizer spreaders, salt spreaders and agricultural applications where dirt can reach the backside of bearing units.

The nitrile rubber on the 304 stainless steel plate with the drain slot is designed to protect your bearing units in applications that are exposed to moisture and where moisture or water build up can create issues. These backside guards can be utilized in food and beverage applications where they are being washed down as well as pharmaceutical applications. The stainless steel core is perfect for situations where regular steel can rust quickly.



ORIGINAL DESIGNED SET SCREW



The innovative FYH Bullet Point set screw is a one piece ball point set screw which is designed to expand the threads of the screw as the point of the screw contacts the surface of the shaft. The resulting force creates superior holding power especially where vibration is present. Other set screws have larger contact areas with sharp edges at the point of the screw to bite into the shaft. However, these sharp edges damage more easily from vibration which creates a gap between the point of the set screw and the shaft. Once this gap is established, the set screw will begin to loosen.

When the Bullet Point set screw is tightened, the original shape of the point causes the threads of the screw to expand up to and beyond the elastic limit to achieve the maximum possible holding power. The thickness of the point is also designed to expand easily. This specialized design drastically reduces the potential for damage to both the set screw and shaft from normal use or for severe vibration, shock load, and high speed.

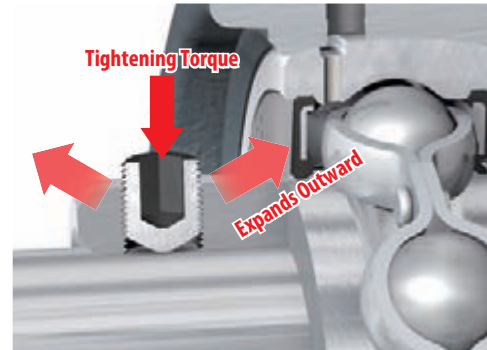

360° SHAFT CONTACT TRUE Concentric-LOC

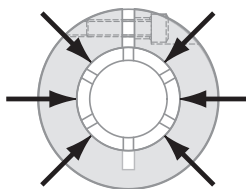

The **FYH NU-LOC** bearing grips the shaft more uniformly, which allows for 360 degrees of equalized locking contact. Compared to set screw bearings, the roundness of the ball path on the NU-LOC bearings results in better operation and longer life.

NU-LOC concentric locking collars are designed to prevent shafting from becoming marred or burred. A single standard hex head cap screw can be tightened quickly and easily, and NU-LOC bearings can replace either setscrew or eccentric locking collar inserts.

NU-LOC concentric locking collar with a single cap screw provides excellent holding power. The collar is installed over the slotted inner ring on the shaft concentrically. Quick & Easy Installation with a single hex cap screw.

NU-LOC's standard tolerance specification is designed for air handling applications, and the greater roundness of the ball path enable the use of smaller internal ball clearance.

The bore tolerance is also smaller since NU-LOC has the 360 degrees of equalized locking contact. NU-LOC is not only good for the air handling applications, but great for the other applications as well.

3 Models

3.1 Model List

Table 3.1 and Table 3.2 shows the models of FYH Ball Bearing Units and ball bearing inserts.

Table 3.1 FYH Ball Bearing Units models

Model	Type	Bearing bore dia. Surface (fixing to shaft)	Model code	Shaft dia.				Dimension table		
				(inch)		(mm)				
				min.	max.	min.	max.			
1 Pillow Block Units	(1) Pillow Block Units	with set screws with eccentric locking collar	UCP	1/2	4	12	140	P.82		
			NAP	1/2	2 15/16	12	75	P.88		
			NAP-E	1 3/16	2 15/16	–	–	P.90		
			NAPK	1/2	2 15/16	12	75	P.92		
		with concentric locking collar Tapered bore (with adapter)	NCP	3/4	2 7/16	20	60	P.94		
			UKP	3/4	4 1/2	20	125	P.96		
			(2) Thick Pillow Block Units	with set screws Tapered bore (with adapter)	UCIP	1 1/2	4	40	140	P.102
				UKIP	1 1/4	4 1/2	35	125	P.104	
	(3) Tapped-Base Pillow Block Units	with set screws	UCPA	1/2	2	12	50	P.106		
			UCPAN	3/4	1 7/16	20	35	P.108		
		with concentric locking collar	NCPA	3/4	2	20	50	P.110		
			NCPAN	3/4	1 7/16	20	35	P.112		
	(4) High-Base Pillow Block Units	with set screws	UCPH	1/2	2	12	50	P.114		
	(5) Narrow Inner Ring Bearing Pillow Block Units	with set screws with eccentric locking collar	SBP-RKP8	3/4	1 1/2	20	40	P.116		
			SAP-FP9	3/4	2 3/16	20	55	P.116		
		with set screws with eccentric locking collar	SBPAN-RKP8	3/4	1 7/16	20	35	P.118		
			SAPAN-FP9	3/4	1 7/16	20	35	P.118		
	(6) Light Pillow Block Units	with set screws with eccentric locking collar	BLP	1/2	1 1/2	12	40	P.120		
		ALP	1/2	1 9/16	12	40	P.120			
	(7) Compact Pillow Block Units	with set screws	UP	–	–	10	30	P.122		
	(8) Corrosion Resistant Series Pillow Block Units	with set screws	UCSP-H1S6	1/2	2 7/16	12	60	P.124		
UCSPA-H1S6			1/2	1 9/16	12	40	P.126			
USP-S6			–	–	10	30	P.128			
UCVP-S6			3/4	2	20	50	P.130			
UCVP-ES7			3/4	2	20	50	P.132			
UCVPAN-ES7			3/4	1 7/16	20	35	P.134			
(9) Stamped Steel Pillow Block Units	with set screws with eccentric locking collar	SBPP	1/2	1 1/4	12	30	P.136			
		SAPP	1/2	1 1/4	12	30	P.136			
2 4-Bolt Flange Units	(1) 4-Bolt Flange Units	with set screws	UCF	1/2	4	12	140	P.138		
			UCF-E	1/2	3 7/16	12	85	P.144		
			NANF	1/2	2 7/16	12	60	P.148		
		with eccentric locking collar with concentric locking collar	NCF	3/4	2 7/16	20	60	P.150		
			NCF-E	3/4	2 7/16	20	60	P.152		
			UKF	3/4	4 1/2	20	125	P.154		
	(2) Square Piloted 4-Bolt Flange Units	with set screws Tapered bore (with adapter)	UCFS	1	4	25	140	P.160		
		UKFS	3/4	4 1/2	20	125	P.162			
	(3) Narrow Inner Ring Bearing 4-Bolt Flange Units	with set screws with eccentric locking collar	SBF-RKP8	3/4	1 1/2	20	40	P.164		
			SAF-FP9	3/4	2 3/16	20	55	P.164		
	(4) Corrosion Resistant Series 4-Bolt Flange Units	with set screws	UCSF-H1S6	3/4	2 7/16	20	60	P.166		
			UCSF-EH1S6	3/4	2 7/16	20	60	P.168		
			UCVF-S6	3/4	1 9/16	20	40	P.170		
			UCVF-ES7	3/4	1 9/16	20	40	P.172		
	3 Oval Flange Units	(1) 2-Bolt Flange Units	with set screws	UCFL	1/2	4	12	120	P.174	
				UCFL-E	1/2	3 1/4	12	85	P.180	
NANFL				1/2	2 3/16	12	55	P.184		
with eccentric locking collar with concentric locking collar			NCFL	3/4	2 7/16	20	60	P.186		
			NCFL-E	3/4	2 7/16	20	60	P.188		
			UKFL	3/4	4	20	110	P.190		
(2) Adjustable 2-Bolt Flange Units		with set screws	UCFA	1/2	2 3/16	12	55	P.194		
(3) 3-Bolt Flange Units		with set screws	UCFB	1/2	2	12	50	P.196		
(4) Narrow Inner Ring Bearing 2-Bolt Flange Units		with set screws with eccentric locking collar	SBFL-RKP8	3/4	1 1/2	20	40	P.198		
		SAFL-FP9	3/4	2 3/16	20	55	P.198			
(5) Light 3-Bolt Flange Units		with set screws with eccentric locking collar	SBTFD-H4RKP8	1/2	1 7/16	12	35	P.200		
		SATFD-FH4P9	1/2	1 7/16	12	35	P.200			
(6) Light 2-Bolt Flange Units		with set screws with eccentric locking collar	BLF	1/2	1 7/16	12	35	P.202		
		ALF	1/2	1 7/16	12	35	P.202			
(7) Compact 2-Bolt Flange Units		with set screws	UFL	–	–	8	30	P.204		
(8) Corrosion Resistant Series 2-Bolt Flange Units	with set screws	UCSFL-H1S6	1/2	2	12	50	P.206			
		UCSFL-EH1S6	1/2	2	12	50	P.208			
		USFL-S6	–	–	10	30	P.210			
		UCVFL-S6	3/4	1 9/16	20	40	P.212			
		UCVFL-ES7	3/4	1 9/16	20	40	P.214			
(9) Corrosion Resistant Series 3-Bolt Flange Units	with set screws	UCVFB-ES7	3/4	1 7/16	20	35	P.216			

Table 3.1 FYH Ball Bearing Units models (continued)

Model	Type	Bearing bore dia. Surface (fixing to shaft)	Model code	Shaft dia.				Dimension table
				(inch)		(mm)		
				min.	max.	min.	max.	
4 4-Bolt Flange Cartridge Units	(1) 4-Bolt Flange Cartridge Units	with set screws	UCFC UCFCX-E UCFCF NCFC UKFC	1/2 1 7/8 3/4 3/4	4 4 2 3/16 2 7/16 3 1/2	12 25 25 20 20	100 100 55 60 90	P.218 P.222 P.224 P.226 P.228
	(2) Narrow Inner Ring Bearing 4-Bolt Flange Cartridge Units	with set screws with eccentric locking collar	SBFC-RKP8 SAFC-FP9	3/4 3/4	1 1/2 2 3/16	20 20	40 55	P.232 P.232
	(3) Corrosion Resistant Series 4-Bolt Flange Cartridge Units	with set screws	UCSFC-H1S6	3/4	1 9/16	20	40	P.234
5 Stamped Steel Flange Units	(1) Stamped Steel 3-Bolt Flange Cartridge Units	with set screws with eccentric locking collar	SBPF SAPF	1/2 1/2	1 7/16 1 7/16	12 12	35 35	P.236 P.236
	(2) Stamped Steel 2-Bolt Flange Units	with set screws with eccentric locking collar	SBPFL SAPFL	1/2 1/2	1 7/16 1 7/16	12 12	35 35	P.238 P.238
6 Take-Up Units	(1) Take-Up Units	with set screws	UCT UCT-E NAT-E NCT NCT-E UKT	1/2 1/2 1/2 3/4 3/4 3/4	4 3 7/16 2 15/16 2 7/16 2 7/16 4 1/2	12 12 12 20 20 20	140 85 75 60 60 125	P.240 P.246 P.250 P.252 P.254 P.256
	(2) Narrow Slot Take-Up Units	with set screws	UCTRS	7/8	1 7/16	25	35	P.260
	(3) Corrosion Resistant Series Take-Up Units	with set screws	UCST-H1S6 UCST-EH1S6	3/4 3/4	2 2	20 20	50 50	P.262 P.264
	(4) Section Steel Frame Take-Up Units	with set screws	UCTH	1/2	2 1/2	12	65	P.266
	(5) Channel Steel Frame Take-Up Units	with set screws	UCTL UCTU	- -	- -	20 40	45 90	P.268 P.270
	(6) Steel Plate Frame Take-Up Units	with set screws	SBPTH SBNPTH	- -	- -	12 12	25 25	P.274 P.276
	7 Other Units	(1) Cartridge Units	with set screws Tapered bore (with adapter)	UCC UKC	1/2 3/4	4 4 1/2	12 20	140 125
(2) Hanger Units		with set screws	UCHA	1/2	3	12	75	P.284

Table 3.2 Bearing insert models

Model	Type	Bearing bore dia. Surface (fixing to shaft)	Model code	Shaft dia.				Dimension table
				(inch)		(mm)		
				min.	max.	min.	max.	
8 Ball Bearing Inserts	(1) UC inserts UC inserts (Stainless steel)	with set screws	UC UC-S6	1/2 1/2	4 2 7/16	12 12	140 60	P.286 P.294
	(2) UK inserts	Tapered bore (with adapter)	UK	3/4	4 1/2	20	125	P.306
	(3) NC inserts	with concentric locking collar	NC	3/4	2 7/16	20	60	P.302
	(4) NA inserts	with eccentric locking collar	NA	1/2	3	12	75	P.296
	(5) SB inserts (Lightweight)	with set screws	SB SB-RKP8	1/2 1/2	1 1/2 1 1/2	12 12	40 40	P.286 P.286
	(6) SA inserts (Lightweight)	with eccentric locking collar	SA SA-F	1/2 1/2	1 9/16 2 3/16	12 12	40 55	P.296 P.296
	(7) SU inserts. Small size SU inserts. Small size (Stainless steel)	with set screws	SU SU-S6	- -	- -	8 10	30 30	P.286 P.294
	(8) Cylindrical O.D. (with lubricating mechanism and snap ring)	with set screws with concentric locking collar	ER ERC	1/2 3/4	2 7/16 2 7/16	12 20	60 60	P.312 P.304
	(9) Cylindrical O.D.	with set screws	RB	1/2	1 9/16	12	40	P.312
	(10) Standard	Cylindrical bore	SC	-	-	17	40	P.316
	(11) Cylindrical O.D.	with set screws with eccentric locking collar	SBB-RK SAA-F	1/2 1/2	1 1/2 2 3/16	12 12	40 55	P.314 P.314
	(12) Adapter		H2300X	3/4	5	20	125	P.318



STANDARD

3.2 Models and Features

FYH Ball Bearing Units are available in a variety of styles and sizes. Models and features of the Ball Bearing Units are shown below.

Note ¹⁾ Descriptions of codes for units with covers are shown in the table below. (common to all the models)

Diameter series	Code	Descriptions
2	C, CD	Stamped steel plate cover type
	FC, FCD	Cast iron cover type
X	C, CD	From X05 to X17: Stamped steel plate cover type X18 and X20: Cast iron cover type
3	C, CD	Cast iron cover type

1 Pillow Block Units

1 Pillow Block Units



UCP



NAP

UCP is a pillow block unit with a rigid cast iron housing and two specially designed set screws in the inner-ring spaced at 120 degrees for maximum holding power and reliability for a wide variety of applications and operating conditions.

Duty: Standard, Medium, Heavy

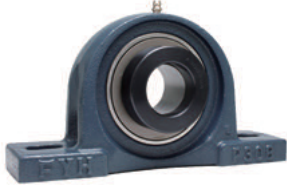

NAP-E



NAPK

NAP is a pillow block unit with an eccentric locking collar insert that provides a very secure grip to the shaft that becomes even more secure during continued operation. It is specifically used for single-direction/non-reversing rotation.

Duty: Standard, Heavy

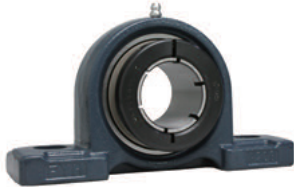

NCP



UKP+H

NCP is a pillow block unit with a specially designed concentric locking collar that provides 360 degrees of shaft contact. It produces a more concentric lock on the shaft compared to other locking styles and it functions very well for high speed applications.

Duty: Standard

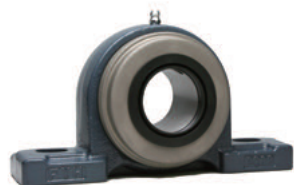

UCP-C, CD
UKP-C, CD

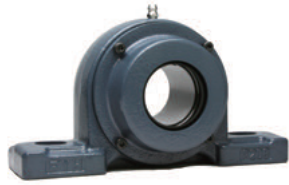

UCP-FC, FCD
UKP-FC, FCD

UKP is a pillow block unit with a tapered-bore bearing insert that utilizes an adapter sleeve assembly to produce a highly concentric and secure lock on the shaft to reduce slippage and fretting corrosion even under adverse conditions.

Duty: Standard, Medium, Heavy

2 Thick Pillow Block Units

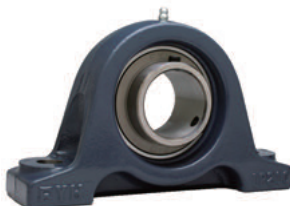

UCIP

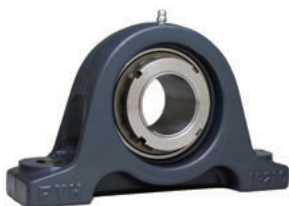

UKIP+H

UCIP is a pillow block unit with a highly rigid and rugged casting for particularly demanding applications. The two bolt holes are round for more accurate positioning and the strength ratings of the housing are substantially improved over standard pillow block housings. UK style is also available.

Duty: Standard, Heavy

3 Tapped-Base Pillow Block Units



UCPA



UCPAN



NCPA



NCPAN

UCPA and **UCPAN** are tapped-base pillow blocks with threaded bolt holes in the bottom of the housings. They are ideal for exact unit positioning and limited space applications. They are available in both inch and metric bolt-hole dimensions. NA, NC & UK style are also available.

Duty: Standard

4 High-Base Pillow Block Units



UCPH

UCPH is a pedestal pillow block unit with an exceptionally high mounting base. It is ideal for applications where a shouldered shaft could create interference with the mounting surface when using a standard pillow block unit.

Duty: Standard

5 Narrow Inner Ring Bearing Pillow Block Units

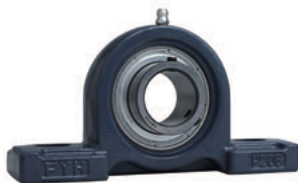

SBP-RKP8



SAP-FP9



SBPAN-RKP8



SAPAN-FP9

SBP-RKP8 is a lightweight bearing mounted pillow block unit which is ideal for limited space applications and light to moderate duty applications.

SAP-FP9 with SA eccentric locking collar style is also available.

SBPAN-RKP8 is a lightweight bearing mounted tapped-base pillow block unit which is ideal for limited space applications and light to moderate duty applications.

SAPAN-FP9 with SA eccentric locking collar style is also available.

Duty: Standard

3 Models

(1 Pillow Block Units)

6 Light Pillow Block Units



BLP



ALP

BLP is a compact and lightweight pillow block unit which is ideal for limited space applications and light to moderate duty applications.

ALP with SA eccentric locking collar style is also available.

Duty: Light

7 Compact Pillow Block Units



UP



UP-C, CD

UP is a light duty pillow block unit that is part of the Clean Series. It has a zinc-alloy housing for a high level of corrosion resistance and it is capable of accepting end covers to increase contamination resistance.

Duty: Light

8 Corrosion Resistant Series Pillow Block Units

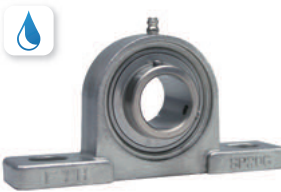

UCSP-H1S6



USP-S6

UCSP is a pillow block unit that is made entirely out of stainless steel components for the highest level of corrosion resistance for a mounted bearing unit. It is also pre-filled with food grade grease for food processing applications.

Duty: Standard



UCSPA-H1S6



UCVP-S6
UCVP-ES7

USP-S6 is a light duty stainless pillow block unit that is part of the Clean Series. It has a stainless housing for a high level of corrosion resistance and it is capable of accepting end covers to increase contamination resistance.

Duty: Light

UCSPA is a tapped-base pillow block unit with threaded bolt holes in the bottom of the housings. It is made entirely out of stainless steel components for the highest level of corrosion resistance for a mounted bearing unit. It is ideal for exact unit positioning and limited space applications. It is also pre-filled with food grade grease for food processing applications.

Duty: Standard



UCVPAN-ES7

UCVP and **UCVPAN** is a pillow block unit with a corrosion resistant thermoplastic housing and the option of either a stainless steel bearing insert or a zinc chromate plated bearing insert. Both bearing inserts offer a high level of corrosion resistance and they are factory lubricated with food grade grease.

Duty: Standard

9 Stamped Steel Pillow Block Units



SBPP



SAPP

SBPP is a pillow block unit with a lightweight and compact stamped steel housing for light to moderate duty applications. **SAPP** with SA eccentric locking collar style is also available.

Duty: Light

2 4-Bolt Flange Units

1 4-Bolt Flange Units



UCF
UCF-E



NANF

UCF is a four-bolt flange unit with a rigid cast iron housing and two specially designed set screws in the inner-ring spaced at 120 degrees for maximum holding power and reliability for a wide variety of applications and operating conditions. UK style is also available.

Duty: Standard, Medium, Heavy

NANF is a four-bolt flange unit with an eccentric locking collar insert that provides a very secure grip to the shaft that becomes even more secure during continued operation. It is specifically used for single-direction/non-reversing rotation.

Duty: Standard



NCF
NCF-E



UKF+H

NCF is a four-bolt flange unit with a specially designed concentric locking collar that provides 360 degrees of shaft contact. It produces a more concentric lock on the shaft compared to other locking styles and it functions very well for high speed applications.

Duty: Standard

2 Square Piloted 4-Bolt Flange Units



UCFS



UKFS+H

UCFS is a piloted four-bolt flange unit available with a heavy duty bearing insert for a demanding operating environment. The pilot on the back of the housing allows for precise mounting where necessary. UK style is also available.

Duty: Heavy

3 Narrow Inner Ring Bearing 4-Bolt Flange Units



SBF-RKP8



SAF-FP9

SBF-RKP8 is a lightweight bearing mounted four-bolt Flange units which is ideal for limited space applications and light to moderate duty applications.

SAF-FP9 with SA eccentric locking collar style is also available.

Duty: Standard

4 Corrosion Resistant Series 4-Bolt Flange Units



UCSF-H1S6
UCSF-EH1S6



UCVF-S6
UCVF-ES7

UCSF is a four-bolt flange unit that is made entirely out of stainless steel components for the highest level of corrosion resistance for a mounted bearing unit. It is also pre-filled with food grade grease for food processing applications.

UCVF is a four-bolt flange unit with a corrosion resistant thermo-plastic housing and the option of either a stainless steel bearing insert or a zinc chromate plated bearing insert. Both bearing inserts offer a high level of corrosion resistance and they are factory lubricated with food grade grease.

Duty: Standard

3 Oval Flange Units

1 2-Bolt Flange Units



UCFL
UCFL-E



NANFL



NCFL
NCFL-E



UKFL+H

UCFL is a two-bolt flange unit with a rigid cast iron housing and two specially designed set screws in the inner-ring spaced at 120 degrees for maximum holding power and reliability for a wide variety of applications and operating conditions. UK style is also available.

Duty: Standard, Medium, Heavy

NANFL is a two-bolt flange unit with an eccentric locking collar insert that provides a very secure grip to the shaft that becomes even more secure during continued operation. It is specifically used for single-direction/non-reversing rotation.

Duty: Standard

NCFL is a two-bolt flange unit with a specially designed concentric locking collar that provides 360 degrees of shaft contact. It produces a more concentric lock on the shaft compared to other locking styles and it functions very well for high speed applications.

Duty: Standard

2 Adjustable 2-Bolt Flange Units



UCFA

UCFA is an adjustable two-bolt flange unit with a rigid cast iron housing and two specially designed set screws in the inner-ring spaced at 120 degrees for maximum holding power and reliability for a wide variety of applications and operating conditions.

Duty: Standard

3 3-Bolt Flange Units



UCFB

UCFB are three-bolt flange brackets with rigid cast iron housings and two specially designed set screws in the inner-ring spaced at 120 degrees for maximum holding power and reliability for a wide variety of applications and operating conditions. They are available in both inch and metric bolt-hole dimensions.

Duty: Standard

4 Narrow Inner Ring Bearing 2-Bolt Flange Units



SBFL-RKP8



SAFL-FP9

SBFL-RKP8 is a lightweight bearing mounted two-bolt flange units which is ideal for limited space applications and light to moderate duty applications.

SAFL-FP9 with SA eccentric locking collar style is also available.

Duty: Standard

5 Light 3-Bolt Flange Units



SBTFD-H4RKP8



SATFD-FH4P9

SATFD is a compact and lightweight three-bolt flange unit with square bolt holes for carriage bolts and a ductile iron housing for added strength. It is ideal for limited space applications and light to moderate duty applications.
with ductile iron housing

Duty: Light

6 Light 2-Bolt Flange Units



BLF



ALF

BLF is a compact and lightweight two-bolt flange unit which is ideal for limited space applications and light to moderate duty applications.

ALF with SA eccentric locking collar style is also available.

Duty: Light

7 Compact 2-Bolt Flange Units



UFL



UFL-C, D

UFL is a light duty two-bolt flange unit that is part of the Clean Series. It has a zinc-alloy housing for a high level of corrosion resistance and it is capable of accepting end covers to increase contamination resistance.

Duty: Light

8 Corrosion Resistant Series 2-Bolt Flange Units



UCSFL-H1S6
UCSFL-EH1S6



USFL-S6

UCSFL is a two-bolt flange unit that is made entirely out of stainless steel components for the highest level of corrosion resistance for a mounted bearing unit. It is also pre-filled with food grade grease for food processing applications.

Duty: Standard

USFL-S6 is a light duty stainless two-bolt flange unit that is part of the Clean Series. It has a stainless housing for a high level of corrosion resistance and it is capable of accepting end covers to increase contamination resistance.

Duty: Light



UCVFL-S6
UCVFL-E57

UCVFL is a two-bolt flange unit with a corrosion resistant thermoplastic housing and the option of either a stainless steel bearing insert or a zinc chromate plated bearing insert. Both bearing inserts offer a high level of corrosion resistance and they are factory lubricated with food grade grease.

Duty: Standard

3 Models

(3 Oval Flange Units)

9 Corrosion Resistant Series 3-Bolt Flange Units



UCVFB-ES7

UCVFB is a three-bolt flange unit that is made entirely out of stainless steel components for the highest level of corrosion resistance for a mounted bearing unit. It is also pre-filled with food grade grease for food processing applications.

Duty: Standard

4 4-Bolt Flange Cartridge Units

1 4-Bolt Flange Cartridge Units



UCFC
UCFCX-E
UCFCF



NCFC

UCFC is piloted flange cartridge units with rigid cast iron housings and two specially designed set screws in the inner-ring spaced at 120 degrees for maximum holding power and reliability for a wide variety of applications and operating conditions. The pilot on the back of the housing allows for precise mounting where necessary. UK, NA styles are also available.

Duty: Standard, Medium

NCFC is a piloted flange cartridge unit with a specially designed concentric locking collar that provides 360 degrees of shaft contact. It produces a more concentric lock on the shaft compared to other locking styles and it functions very well for high speed.

Duty: Standard



UKFC+H

2 Narrow Inner Ring Bearing 4-Bolt Flange Cartridge Units



SBFC-RKP8



SAFC-FP9

SBFC-RKP8 is a lightweight bearing mounted 4-Bolt Flange Cartridge Units which is ideal for limited space applications and light to moderate duty applications.

SAFC-FP9 with SA eccentric locking collar style is also available.

Duty: Standard

3 Corrosion Resistant Series 4-Bolt Flange Cartridge Units



UCSFC-H1S6

UCSFC is a four-Bolt Flange Cartridge Units that is made entirely out of stainless steel components for the highest level of corrosion resistance for a mounted bearing unit. It is also pre-filled with food grade grease for food processing applications.

Duty: Standard

5 Stamped Steel Plate Flange Units

1 Stamped Steel 3-Bolt Flange Cartridge Units



SBPF



SAPF

SBPF is a round three-bolt flange unit with a lightweight and compact stamped steel housing for light to moderate duty applications.

SAPF with SA eccentric locking collar style is also available.

Duty: Light

2 Stamped Steel 2-Bolt Flange Units



SBPFL



SAPFL

SBPFL is a two-bolt flange unit with a lightweight and compact stamped steel housing for light to moderate duty applications.

SAPFL with SA eccentric locking collar style is also available.

Duty: Light

6 Take-Up Units

1 Take-Up Units



UCT
UCT-E



NAT-E

UCT is a wide-slot take-up unit suitable for use in a side-mount take-up frame. It has a rigid cast iron housing and two specially designed set screws in the inner-ring spaced at 120 degrees for maximum holding power and reliability for a wide variety of applications and operating conditions.

UK style is also available.

Duty: Standard, Medium, Heavy

NAT is a wide-slot take-up unit with an eccentric locking collar insert that provides a very secure grip to the shaft that becomes even more secure during continued operation. It is specifically used for single-direction/non-reversing rotation.

Duty: Standard



NCT
NCT-E



UKT+H

NCT is a wide-slot take-up unit with a specially designed concentric locking collar that provides 360 degrees of shaft contact. It produces a more concentric lock on the shaft compared to other locking styles and it functions very well for high speed applications.

Duty: Standard



UCTRS

UCTRS is a narrow slot take up unit. It has a rigid cast iron housing and two specially designed set screws in the inner-ring spaced at 120 degrees for maximum holding power and reliability for a wide variety of applications and operating conditions.

Duty: Standard

3 Models

(6 Take-Up Units)

2 Corrosion Resistant Series Take-Up Units



UCST-H1S6
UCST-EH1S6

UCST is a wide-slot take-up unit that is made entirely out of stainless steel components for the highest level of corrosion resistance for a mounted bearing unit. It is also pre-filled with food grade grease for food processing applications.

Duty: Standard

3 Section Steel Frame Take-Up Units



UCTH

UCTH is a Take-Up unit with section a steel frame.

Duty: Standard

4 Channel Steel Frame Take-Up Units



UCTL



UCTU

UCTL is a Take-Up unit with a channel steel frame.

Duty: Standard

UCTU is a Take-Up unit with a channel steel frame.

Duty: Standard, Heavy

5 Steel Plate Frame Take-Up Units



SBPTH



SBNPTH

SBPTH is a Take-Up unit with a steel plate frame.

Duty: Standard

SBNPTH is a Take-Up unit with a steel plate frame.

Duty: Standard

7 Other Units

1 Cartridge Units



UCC



UKC+H

UCC is a cartridge unit with two specially designed set screws in the inner-ring spaced at 120 degrees for maximum holding power and reliability for a wide variety of applications and operating conditions. The cartridge housing allows for precise shaft mounting and expansion capability where necessary. UK, NA, NC styles are also available.

Duty: Standard, Medium, Heavy

2 Hanger Units



UCHA

UCHA is a hanger unit with a threaded-base for simple installation on a threaded pipe mounting configuration. It has two specially designed set screws in the inner-ring spaced at 120 degrees for maximum holding power and reliability for a wide variety of applications and operating conditions.

Duty: Standard

8 Ball Bearing Inserts

1 UC inserts

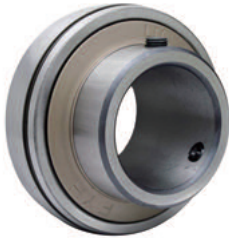

UC



UC-L3



UC-S6

with set screws

UC2 (X, 3)...Standard type Duty: Standard, Medium, Heavy

UC2 (X, 3) L3...Triple-lip seal type

UC2-S6...Stainless steel series Duty: Standard

This deep grooved ball bearing insert with rubber seal and metal slinger comes pre-lubricated with FYH grease. This insert incorporates a wide inner ring design with FYH Bullet Point setscrews as a standard, at 120 degrees apart to affix the insert to the shafting. The setscrew locking design with wide inner ring is the most common insert and can be used in a wide variety of applications. The spherical O.D. of the insert has both a grease groove as well as grease holes to re-lubricate the insert when needed. The UC insert can be ordered with a triple lip seal by using a L3 designation in the suffix.

The UC-S6 series incorporates the same design and dimensions as a standard UC insert but is constructed of 316 grade stainless steel for wash down and other corrosive environments. These inserts come with food grade grease as a standard, and a primary used in food, pharmaceutical, fertilizer and demanding applications.

2 UK inserts



UK

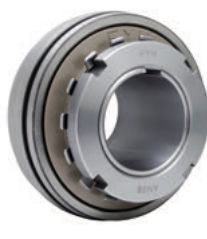

UK+H



UK-L3



UK-L3+H

with adapter

UK2 (X, 3)...Standard type Duty: Standard, Medium, Heavy

UK2 (3) L3...Triple-lip seal type

This deep grooved ball bearing insert with rubber seal and metal slinger comes pre-lubricated with FYH grease. The UK series incorporates a tapered inner ring and uses corresponding adaptors to determine the bore size and affix it to the shaft. The UK series is perfect for applications where shock load can damage other locking devices. The tapered bore with adaptor provides true 360 degree shaft contact that runs the entire length of the inner ring. The spherical O.D. has a grease groove and grease holes for re-lubrication. The insert and adaptor come as two separate items and must be ordered separately. The insert is also available in a triple lip design by adding the L3 designation to the suffix.

3 NC inserts



NC

with concentric locking collar

NC2 Duty: Standard

The FYH NU-LOC bearing features a concentric locking collar that allows for 360 degrees of locking contact. This deep groove ball bearing insert uses a grooved inner ring with a collar that incorporates a hex screw that is tightened to squeeze equally against the inner ring. The NU-LOC insert has a spherical O.D. and has grease grooves and grease holes for re-lubricating.

The roundness of the ball path created by the NU-LOC bearing results in better operation and longer life. The collar is designed to prevent shaft marring and burring that can occur with other locking options.

3 Models

(8 Ball Bearing Inserts)

4 NA inserts



NA

with eccentric locking collar

NA2

Duty: Standard, Heavy

This deep groove ball bearing insert with rubber seal and metal slinger comes pre-lubricated with FYH grease. This insert incorporates a wide inner ring design with an eccentric locking collar for securing the insert to the shafting. The insert has grease holes and a grease groove on the outer ring for re-lubrication.

The spherical O.D. allows this insert to be installed in a wide range of housings. When the insert is affixed to the shaft, the eccentric collars' elliptical shape meshes with the elliptical surface of the inner ring.

The turning of the inner ring locks the shafting in place and a setscrew is tightened to keep it from slipping.

5 SB inserts

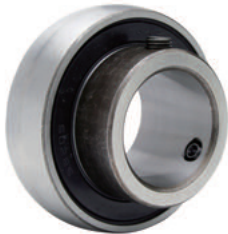

SB



SB-RKP8

with set screws

SB2

Duty: Light

This is a deep groove ball bearing insert with spherical O.D. comes from the factory pre-lubricated with FYH grease. This bearing can be ordered in either re-lube style or sealed for life. The re-lube style has a grease groove and grease holes on the O.D. while the lubed for life does not. The SB series has the same load ratings as a UC bearing but has a narrow inner ring, and uses a one piece seal and slinger design rather than a separate seal and slinger. This insert affixes to the shafting using two set screws at 120 degrees apart. To order this same bearing with a cylindrical O.D. use the designation SBB.

6 SA inserts



SA

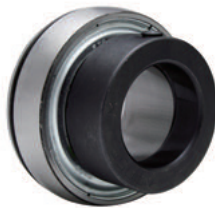

SA-F

with eccentric locking collar

SA2, SA2-F

Duty: Light

This deep groove ball bearing unit with spherical O.D. is the same as the SB type insert, but uses an eccentric locking collar for affixing to the shafting. This insert comes from the factory pre-lubricated with FYH grease. This bearing can be ordered in either re-lube style or sealed for life. The re-lube style has a grease groove and grease holes on the O.D. while the lubed for life does not. This series also has a re-lube backside style. The backside re-lube is designated by an F in the suffix to be compatible with others in the industry. When the insert is affixed to the shaft, the eccentric collars' elliptical shape meshes with the elliptical surface of the inner ring.

The turning of the inner ring locks the shafting in place and a setscrew is tightened to keep it from slipping. To order this same bearing with a cylindrical O.D. use the designation SAA.



SA-FP9

7 SU inserts (Small size)



SU



SU-S6

with set screws

SU0...Standard type

Duty: Light

SU0-S6...Stainless steel

This deep groove ball bearing insert is intended for very light loads and is used in light duty conveying applications as part of our Clean Series. This bearing has a spherical O.D. and comes pre-lubricated from the factory. These inserts have a spherical O.D. with a wider inner ring and have no grease groove or grease holes for re-lubrication. Two setscrews at 120 degrees apart affix this insert to the shafting. The SU-S6 bearing is constructed of stainless steel material and is used as part of our stainless Clean Series. The stainless material is superior in corrosion resistance compared to the normal clean series insert.

8 ER inserts



ER



ERC

with set screws, cylindrical O.D. lubricating mechanism, locating snap ring and snap ring groove

ER2, ERC2

Duty: Standard

This deep groove ball bearing insert with a rubber seal and metal slinger come pre-lubricated with FYH grease. The ER series has a cylindrical O.D. with grease groove and grease holes outer ring for re-lubrication. The ER series uses two FYH Bullet Point type setscrews at 120 degrees apart to affix it to the shafting. The ER bearings have a snap ring on the outer ring to help make locating the bearing a simple task during installation. ERC with NU-LOC concentric locking collar style is also available.

9 RB inserts

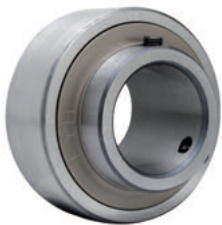

RB

with set screws, cylindrical O.D.

RB2

Duty: Standard

This deep groove ball bearing insert with a rubber seal and metal slinger come pre-lubricated with FYH grease. The RB series has a cylindrical O.D. and has the same dimensions as the ER series but does not have a snap ring for locating or a grease groove and grease holes for re-lubrication. The RB series uses two FYH Bullet Point type setscrews at 120 degrees apart to affix it to the shafting.

3 Models

(8 Ball Bearing Inserts)

10 SC inserts



SC

SC2

Duty: Light

The SC series is a non-extending inner ring insert with a spherical outer-diameter which allows it to be mounted in a traditional housing. The bore tolerance is more precise than typical mounted bearings so press-fit shaft mounting can be accomplished.

11 SBB, SAA inserts



SBB-RK



SAA-F

with set screws, cylindrical O.D.

SBB2, SAA2-F

Duty: Light

The SBB and SAA insert series' both have a cylindrical outer diameter for press-fit mounting directly into component machinery. They are not self-aligning or capable of being mounted into traditional housings.

12 Adapter



H2300X

Adapter

H2300X

The H2300X adapter series' are for use in the tapered-bore UK series. Proper assembly of adapter sleeves can create excellent holding power on the shaft.

4 Rating Life of Bearings

When ball bearing units are installed and operated on a piece of machinery eventually a failure will occur. The period of operation until the unit cannot be used due to failure is called the bearing life.

Bearing failure is caused by two main reasons. The first is fatigue of bearing material, and the second is lubricant degradation. The life is figured on whichever fails first.

Proper bearing lubrication will eliminate grease degradation and allow full bearing life to be achieved. If the bearing units are run without replenishment of the grease the bearing life will have to be factored by either the grease life or the bearing life. During installation, care must be taken not to damage the bearing. Proper bearing maintenance and lubrication will ensure long bearing life.

4.1 Basic Rating Life and Basic Load Rating

4.1.1 Basic rating life

When a bearing is rotated under load the raceways and the rolling elements are continuously exposed to load. Damage, such as scaling (flaking or peeling), eventually appears on the material, and the total rotating frequency until the damage appears is called the “fatigue limit of the bearing”. Fatigue limit of the bearing can vary greatly even if the bearings have the same structure, dimensions, materials, machining methods, and are operated under the same conditions.

To account for this variation, a group of the same bearings operating under the same conditions are tested, and the total rotating frequency of 90% of the bearings operating with no damage due to rotating fatigue (90% reliability) is called the basic load rating.

4.1.2 Basic load rating

Dynamic ratings are determined by placing a pure radial load on a radial bearing or by placing a central axial load on a thrust bearing. The dynamic rating is the load that the bearing will withstand for one million cycles before failure of the bearing.

These ratings are referred to as the **basic dynamic radial load rating** (C_r) or the **basic dynamic axial load rating** (C_a). These values are indicated in the catalog as the basic dynamic radial load rating (C_r), and the value is shown in the dimensional table.

4.2 Calculation of Rating Life

The relationship between the basic rating life, the basic dynamic load rating, and the dynamic equivalent load of the ball bearing is indicated in **Formula (4.1)**. If the ball bearing unit is being used at a fixed rotating speed, the life is indicated as time. This is shown in **Formula (4.2)**.

$$\text{(Total rotating frequency)} \quad L_{10} = \left(\frac{C_r}{P_r}\right)^3 \dots\dots\dots (4.1)$$

$$\text{(Time)} \quad L_{10h} = \frac{10^6}{60n} \left(\frac{C_r}{P_r}\right)^3 \dots (4.2)$$

Whereas,

L_{10} : Basic rating life, 10^6 rotations

L_{10h} : Basic rating life, hr

C_r : Basic dynamic load rating, N

P_r : Dynamic equivalent load, N
(see “5 Bearing load”)

n : Rotating speed, min^{-1}

Calculation of the basic rating life using the life factor (f_h) and the speed factor (f_n) in **Formula (4.2)** are shown below.

$$L_{10h} = 500 f_h^3 \dots\dots\dots (4.3)$$

$$\text{Life factor} \quad f_h = f_n \cdot \frac{C_r}{P_r} \dots\dots\dots (4.4)$$

$$\begin{aligned} \text{Speed factor} \quad f_n &= \left(\frac{10^6}{500 \times 60n}\right)^{1/3} \\ &= (0.03n)^{-1/3} \dots\dots\dots (4.5) \end{aligned}$$

Values of f_n , f_h and L_{10h} can be found using the nomogram of **Fig. 4.1**.

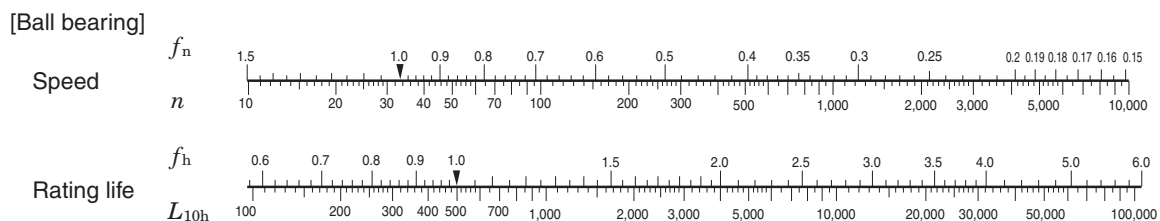

Fig. 4.1 Relation between basic rating life (L_{10h}) and rotating speed (n), speed factor (f_n), and life factor (f_h)

4.2.1 Correction of basic load rating due to temperature

If a ball bearing unit is used at a relatively high temperature the physical composition of the bearing material is changed leading to decreased hardness. This decreased hardness leads to the basic dynamic load rating being reduced. Once the structure of the bearing material has been changed, it will remain this way for the life of the unit, even when it returns to room temperature.

When using a ball bearing unit at 150 °C or more, the basic load rating must be corrected by multiplying the basic dynamic load rating shown in the dimensional table by the temperature factor shown in **Table 4.1**.

Table 4.1 Temperature factor

Bearing temperature, °C	125	150	175	200	250
Temperature factor	1	1	0.95	0.9	0.75

4.2.2 Corrected rating life

The basic L_{10} rating life shown in **Formula (4.1)** is the fatigue life of a bearing with 90% reliability however; there are circumstances where bearings need greater reliability. The bearing life may be extended by using special materials.

Other conditions, including lubrication, may influence the bearing life.

The corrected rating life is found by taking the basic rating life and taking the factors in **Formula (4.6)** into consideration.

$$L_{na} = a_1 a_2 a_3 L_{10} \dots\dots\dots (4.6)$$

Whereas,

- L_{na} : Corrected rating life, 10^6 rotations
Bearing characteristics and operating conditions are taken into consideration with reliability 100– n % (breakage probability)
 - L_{10} : Basic load rating, 10^6 rotations
Life with 90% reliability
 - a_1 : Reliability factor see (1)
 - a_2 : Bearing characterization factor see (2)
 - a_3 : Operating condition factor see (3)
-

(1) Reliability factor a_1

Table 4.2 shows the values used when a corrected bearing life that has less than a 10% breakage probability is necessary.

Table 4.2 Reliability factor a_1

Reliability, %	L_{na}	a_1
90	L_{10a}	1
95	L_{5a}	0.62
96	L_{4a}	0.53
97	L_{3a}	0.44
98	L_{2a}	0.33
99	L_{1a}	0.21

(2) Bearing characterization factor a_2

The material make-up of a bearing can have an affect on its basic rating life. Factors that can influence the bearing include bearing material (type of steel), production procedures, and bearing design. Bearing characterization is shown as factor a_2 .

FYH ball bearing inserts use high quality vacuum degassed bearing steel as standard material, and this material allows for a longer rating life. For FYH ball bearing units, the bearing characterization factor a_2 is 1 ($a_2 = 1$). When bearings with special materials are used for a longer fatigue limit the characterization factor can be shown as a_2 being greater than 1 ($a_2 > 1$).

(3) Operating condition factor a_3

Operating conditions may directly influence the life of the bearing (especially proper or improper lubrication). The basic rating life should be corrected using the operating condition factor a_3 . If lubrication is being maintained the factor $a_3 = 1$. If excellent re-lubrication practices are being maintained the factor $a_3 > 1$ should be applied.

If any of the following operating conditions are applicable the condition should be applied as $a_3 < 1$.

- (1) Kinematic viscosity of lubricant during operation is low:
Ball bearing: 13 mm²/s or less,
Roller bearing: 20 mm²/s or less
- (2) Rotating speed is low:
 d_{mn} : 10,000 or less
- Note: d_m (Pitch dia. of ball set in mm) $\times n$ (Rotating speed)
- (3) Foreign matters are mixed in lubricant

Even if the bearing characterization factor is improved i.e., $a_2 > 1$, the life of the bearing must still be down-rated if the combination, $a_2 \times a_3 > 1$.

4.2.3 Required lifetime of bearings

At some point, the economical nature of a ball bearing begins to decline. The operating conditions, type of bearing used, and type of machine the bearing is used on all influence the operational life of the bearing.

The required lifetime of the ball bearing is shown in **Table 4.3**.

Table 4.3 Required life time of ball bearing units (reference)

Operating conditions	Machines used	Required life time, hrs
Operated in short periods or intermittently	Home electric appliances, electric tools, agricultural machinery, hoist, etc.	4,000 – 8,000
Operated for several minutes or hours at a time, but less than 8 hours per day	Factory motor, ordinary gearing, etc.	12,000 – 20,000
Constantly operated for 8 hours or longer per day or operated continuously for long periods	General machinery, blowers, etc.	20,000 – 30,000
Operated continuously for 24 hours, no fault is allowed	Power plants, mine drainage facility, etc.	100,000 –200,000

4.3 Grease Life

The grease life for ball bearing units is influenced by: the level of the load, rotating speed of the bearing, and the operating temperature.

The grease life for ball bearing units being used under appropriate operating conditions can be found by the formula shown below.

$$\log L = 6.10 - 4.40 \times 10^{-6} d_m n - 2.50 \left(\frac{P_r}{C_r} - 0.05 \right) - (0.021 - 1.80 \times 10^{-8} d_m n) T \dots\dots\dots (4.7)$$

Whereas,

L: Grease life, hr

d_m: Pitch dia. of ball set, mm

$$d_m = \frac{(D + d)}{2}$$

(*D*: Nominal bearing outer dia.,
d: Nominal bearing bore dia.)

n: Rotating speed of bearing, min⁻¹

P_r: Dynamic equivalent radial load, N
(see “5 Bearing load”)

C_r: Basic dynamic radial load rating of bearing, N

T: Operating temperature of bearing, °C

Applicable conditions for the **Formula (4.7)** are shown below.

1) Operating temperature of bearing: *T* °C

To be applied if the following condition is satisfied:
T ≤ 100

(If *T* is smaller than 50 (*T* < 50),
following condition should be applied: *T* = 50.)

If *T* is larger than 100 (*T* > 100), contact FYH.

2) Rotating speed of bearing: *d_mn*

To be applied if the following condition is satisfied:
d_mn ≤ 30 × 10⁴

(If *d_mn* is smaller than 12.5 × 10⁴ (*d_mn* < 12.5 × 10⁴),
following condition should be applied:
d_mn = 12.5 × 10⁴)

If *d_mn* is larger than 30 × 10⁴ (*d_mn* > 30 × 10⁴),
contact FYH.

3) Load condition of bearing: $\frac{P_r}{C_r}$

To be applied if the following condition is satisfied:
 $\frac{P_r}{C_r} \leq 0.2$

(If $\frac{P_r}{C_r}$ is smaller than 0.05 ($\frac{P_r}{C_r} < 0.05$),
following condition should be applied: $\frac{P_r}{C_r} = 0.05$)

If $\frac{P_r}{C_r}$ is larger than 0.2 ($\frac{P_r}{C_r} > 0.2$), contact FYH.

Reference figure of grease life obtained by the **Formula (4.7)** is shown in **Fig. 4.2**.

(1) Bearing load $\cdot \frac{P_r}{C_r} = 0.05$

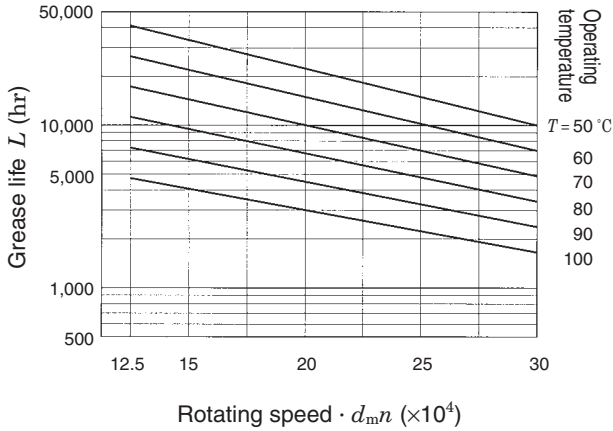

(2) Bearing load $\cdot \frac{P_r}{C_r} = 0.125$

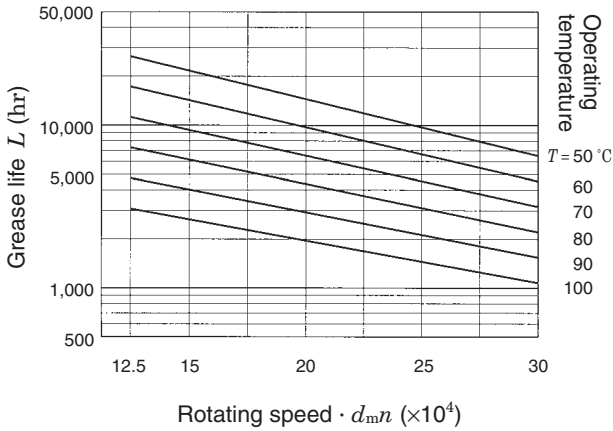

(3) Bearing load $\cdot \frac{P_r}{C_r} = 0.2$

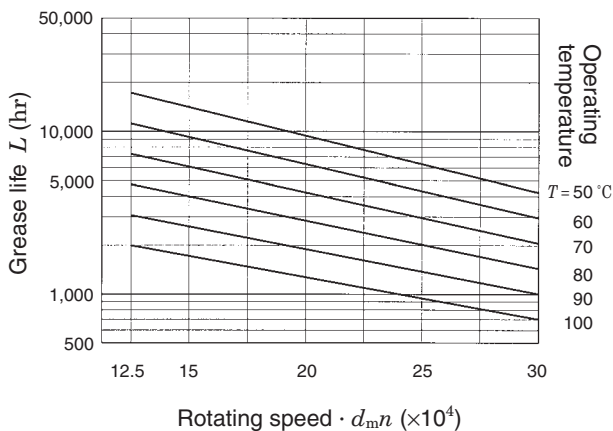

Fig. 4.2 Relation of grease life to bearing load, rotating speed, and operating temperature (reference)

5 Bearing Load

Loads that are applied to bearings come from a variety of sources.

In addition to the primary load, other resultant loads include the weight of complementary objects including shafting, gears, pulleys, torsion from chain and belts, and so on. Shock or dynamic load can also be derived from these sources.

In many cases, these loads cannot be determined by a simple or single calculation; and since these loads often fluctuate in intensity, it is difficult to determine the exact magnitude of them prior to actual lab or field measurements on the machinery in question.

However, in order to approximate the loads involved prior to putting a machine into operation, the technique shown below should be used. This technique uses multiplication factors that have been determined empirically from sample measurements taken on actual machines in operation.

5.1 Loads Applied to Bearings

5.1.1 Load factor

Even if the static radial load and the axial load can be accurately calculated, the actual loads are generally greater than the calculated figures. This is due to the presence of vibration and shock load during actual machine operation.

To find the loads actually applied to a bearing, multiply the values determined for the static load by the following load factors.

$$F = f_w \cdot F_c \dots\dots\dots (5.1)$$

Whereas,

F : Load actually applied to bearing, N

F_c : Theoretically calculated load, N

f_w : Load factor (see **Table 5.1**)

Table 5.1 Load factor f_w

Operating conditions	Applications	f_w
Virtually no vibration or impact	Electric machines and instruments	1 –1.2
Ordinary operation (light impact)	Agricultural machines and blower	1.2–2
Great vibration and impact	Construction machines and grinders	2 –3

5.1.2 Loads from belts or chain drives

The load calculated for the bearing is equal to the tensile load of the belt. However, this load must be multiplied by the load factor (f_w), which accounts for vibration and impact of the machine and a belt factor (f_b), which accounts for the vibration and impact generated through the belt.

When calculating loads for a chain drive, use the same factor (f_b) as used for belt drives.

$$F_b = \frac{2M}{D_p} \cdot f_w \cdot f_b$$

$$= \frac{19.1 \times 10^6 W}{D_p \cdot n} \cdot f_w \cdot f_b \dots\dots\dots (5.2)$$

Whereas,

- F_b : Load actually applied to pulley shaft or sprocket shaft, N
- M : Torque applied to pulley or sprocket, mN · m
- W : Transmitted power, kW
- D_p : Pitch circle dia. of pulley or sprocket, mm
- n : Rotating speed, min⁻¹
- f_w : Load factor (see **Table 5.1**)
- f_b : Belt factor (see **Table 5.2**)

Table 5.2 Belt factor f_b

Belt type	f_b
Toothed belt	1.3–2
V belt	2 –2.5
Flat belt (with tension pulley)	2.5–3
Flat belt	4 –5
Chain	1.2–1.5

5.1.3 Load of gear transmissions

Gear transmissions have a load in the tangential direction (K_t), a load in the radial direction (K_r), and an axial load (K_a). Different types of gears are calculated differently.

The following is a sample of a calculation for an ordinary spur gear arrangement. A flat spur gear will not support an axial load.

- (1) Load applied to gear in tangential direction (tangential line force)

$$K_t = \frac{2M}{D_p} = \frac{19.1 \times 10^6 W}{D_p n} \dots\dots\dots (5.3)$$

- (2) Load applied to gear in radius direction (separating force)

$$K_r = K_t \tan \alpha \dots\dots\dots (5.4)$$

- (3) Synthetic load applied to gear

$$K_g = \sqrt{K_t^2 + K_r^2} = K_t \sec \alpha \dots\dots\dots (5.5)$$

Whereas,

- K_t : Load applied to gear in tangential direction (tangential line force), N
- K_r : Load applied to gear in radius direction (separating force), N
- K_g : Synthetic load applied to gear, N
- M : Torque applied to gear, mN · m
- D_p : Pitch circle dia. of gear, mm
- W : Transmission power, kW
- n : Rotating speed, min⁻¹
- α : Pressure angle of gear, °

Note that the actual gear load must be found by multiplying the theoretical load by the load factor (f_w) obtained by taking into consideration the vibration and impact loads generated while the machine is in operation. The gear factor (f_g) is determined by taking into consideration the accuracy of machining and the finish of the gears.

$$F_g = f_w \cdot f_g \cdot K_g \dots\dots\dots (5.6)$$

Whereas,

- F_g : Load actually applied to gear, N
- K_g : Theoretical synthetic load applied to gear, N
- f_w : Load factor (see **Table 5.1**)
- f_g : Gear factor (see **Table 5.3**)

Table 5.3 Gear factor f_g

Gear type	f_g
Precision gear (both pitch error and tooth profile error should be 0.02 mm or less)	1 –1.1
Ordinary gear (both pitch error and tooth profile error should be 0.1 mm or less)	1.1–1.3

5.2 Distribution of Bearing Load

In order to determine the radial load distribution to each bearing attached to a shaft, use the procedure shown below. Use the load factors shown in **Table 5.1** to account for vibration and impact.

A standard radial ball bearing bears an axial load component in addition to the radial component. The total vectored load can be calculated by taking the square root of the sum of the squares of each load as shown in the previous calculation.

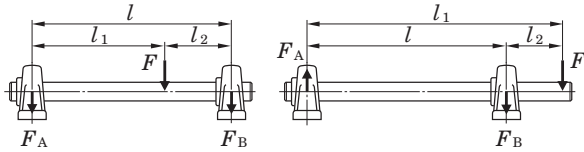

$$F_A = \frac{l_2}{l} \cdot F \dots\dots\dots (5.7)$$

$$F_B = \frac{l_1}{l} \cdot F \dots\dots\dots (5.8)$$

Fig. 5.1 Distribution of load to bearings

5.3 Dynamic Equivalent Load

In many cases, a bearing is exposed to the combined vector load of both radial and axial load components. It may also be used under more severe conditions such as vibration and shock load. In this case, a direct comparison to the dynamic load rating is not appropriate.

In such a case, find the load equivalent to a direct radial load only and compare this with the basic dynamic load rating.

The converted virtual load is called dynamic equivalent load (*P*).

5.3.1 Calculation of dynamic equivalent load

The dynamic equivalent radial load (*P_r*) of a bearing that bears radial and axial loads as well as vibration and impact is found by the following formula.

$$P_r = XF_r + YF_a \dots\dots\dots (5.9)$$

Whereas,

P_r: Dynamic equivalent radial load, N

F_r: Radial load, N

F_a: Axial load, N

X: Radial load factor (see **Table 5.4**)

Y: Axial load factor (see **Table 5.4**)

Table 5.4 Radial load factor (*X*) and axial load factor (*Y*)

$\frac{f_0 F_a}{C_{0r}}$	<i>e</i>	$F_a / F_r \leq e$		$F_a / F_r > e$	
		<i>X</i>	<i>Y</i>	<i>X</i>	<i>Y</i>
0.172	0.19	1	0	0.56	2.30
0.345	0.22				1.99
0.689	0.26				1.71
1.03	0.28				1.55
1.38	0.30				1.45
2.07	0.34				1.31
3.45	0.38				1.15
5.17	0.42				1.04
6.89	0.44				1.00

- Remarks 1. *C_{0r}* (basic static radial load rating) and *f₀* (factor) are shown in the dimensional tables.
 2. If *f₀ F_a / C_{0r}* does not conform to the table above, find by interpolation.

5.3.2 Average dynamic equivalent load in the case of fluctuating loads

If the level or direction of the load applied to a bearing is fluctuating, it is necessary to find the average dynamic equivalent load to calculate the bearing life.

Table 5.5 shows the method of finding the average dynamic equivalent load under various types of fluctuating conditions.

Table 5.5 Calculation of average dynamic equivalent load in case of fluctuated load

(1) Graduated fluctuation

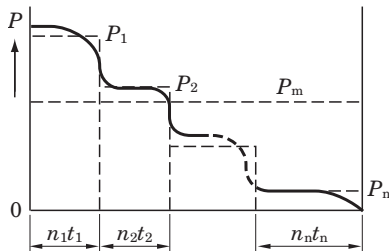

$$P_m = \sqrt[p]{\frac{P_1^p n_1 t_1 + P_2^p n_2 t_2 + \dots + P_n^p n_n t_n}{n_1 t_1 + n_2 t_2 + \dots + n_n t_n}} \quad \dots \dots \dots (5.10)$$

(2) Monotone fluctuation

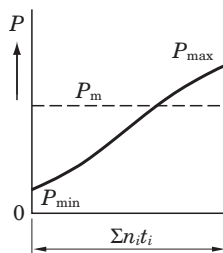

$$P_m = \frac{P_{min} + 2 P_{max}}{3} \quad \dots \dots \dots (5.11)$$

(3) Sine curve fluctuation

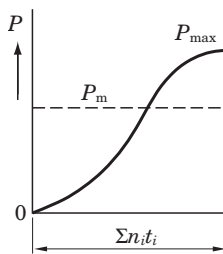

$$P_m = 0.68 P_{max} \quad \dots \dots \dots (5.12)$$

(4) Sine curve fluctuation (upper half of sine curve)

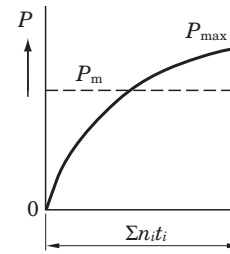

$$P_m = 0.75 P_{max} \quad \dots \dots \dots (5.13)$$

Whereas,

- P_m : Average dynamic equivalent load, N
- P_1 : Dynamic equivalent load actuating for t_1 hours at rotating speed of n_1 , N
- P_2 : Dynamic equivalent load actuating for t_2 hours at rotating speed of n_2 , N
- ⋮
- P_n : Dynamic equivalent load actuating for t_n hours at rotating speed of n_n , N
- P_{min} : Minimum dynamic equivalent load, N
- P_{max} : Maximum dynamic equivalent load, N
- $\Sigma n_i t_i$: Total rotating frequency for t_1 to t_i hours

5.4 Basic Static Load Rating and Static Equivalent Load

5.4.1 Basic static load rating

If a bearing is exposed to excessive static or impact load even when running at low rotational speed, partial permanent deformation occurs to the contact surface of the raceways of the bearing. The amount of permanent deformation increases with increased loads, and at some point, the bearing will no longer rotate smoothly.

The basic static load rating of a bearing is the static load that generates the calculated contact stresses shown below at the center of the contact surfaces of the raceways.

- (1) Self aligning ball bearings 4,600 MPa
- (2) Other ball bearings
(mounted ball bearings included) 4,200 MPa
- (3) Roller bearings 4,000 MPa

The total permanent deformation that occurs to the raceways and the balls under the above critical contact stresses is 0.0001 times the diameter of the ball.

In ball bearing units, this is indicated as the basic static radial load rating (C_{0r}) and these values are shown in the dimensional tables.

5.4.2 Static equivalent loads

Static equivalent load is the equivalent of the combined (vectored) load converted to the equivalent direct radial load. The term “static” refers to no rotation or very little rotation.

Static equivalent radial load (P_{0r}) can be calculated by using the formula below.

$$P_{0r} = 0.6 F_r + 0.5 F_a \dots\dots\dots (5.14)$$

$$P_{0r} = F_r \dots\dots\dots (5.15)$$

Whereas,

P_{0r} : Static equivalent radial load, N

F_r : Radial load, N

F_a : Axial load, N

5.4.3 Safety factor

The static equivalent load that can be withstood by a bearing, in addition to the above considerations, is sometimes dependent upon unforeseen conditions in the operating environment. Therefore, a safety factor is always built in to insure success in the application.

$$f_s = \frac{C_{0r}}{P_{0r}} \dots\dots\dots (5.16)$$

Whereas,

f_s : Safety factor (see **Table 5.6**)

C_{0r} : Basic static radial load rating, N

P_{0r} : Static equivalent radial load, N

Table 5.6 Safety factor f_s (recommended)

Operating conditions		f_s (Min.)
Being rotated	High rotating accuracy is required	2
	Ordinary operating conditions	1
	Impact	1.5
Not always being rotated (sometimes oscillated)	Ordinary operating conditions	0.5
	Impact, unevenly distributed load	1

5.5 Example of Applied Calculation

Example 1 Distributing load

Find the load applied to the bearing A and bearing B, if the radial load F_1 ($F_1 = 1.5$ kN) and F_2 ($F_2 = 4.5$ kN) are applied.

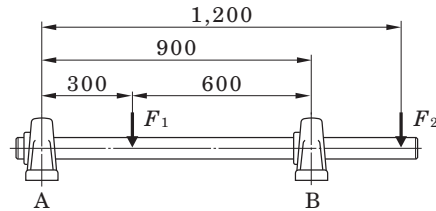

- (1) Find the radial load F_{1A} applied to the bearing A by F_1 , with **Formula (5.7)** and **Formula (5.8)**.

$$F_{1A} = \frac{600}{900} \times 1.5 = 1.0 \text{ (kN)}$$

In a similar manner, find the radial load F_{2A} applied to the bearing A by F_2 .

$$F_{2A} = - \frac{1,200 - 900}{900} \times 4.5 = -1.5 \text{ (kN)}$$

Remark: Negative load is the upward load.

Radial load F_A applied to the bearing A:

$$F_A = F_{1A} + F_{2A} = 1.0 + (-1.5) = -0.5 \text{ (kN)}$$

- (2) In a similar manner to (1), find the radial load F_B applied to the bearing B.

$$F_{1B} = \frac{300}{900} \times 1.5 = 0.5 \text{ (kN)}$$

$$F_{2B} = \frac{1,200}{900} \times 4.5 = 6.0 \text{ (kN)}$$

$$F_B = F_{1B} + F_{2B} = 0.5 + 6.0 = 6.5 \text{ (kN)}$$

Example 2 Calculating load by V-belt transmission

Find the load applied to the bearing A and bearing B when the shaft is driven by the V-belt, transmission power W is 7.5 kw ($W = 7.5 \text{ kW}$), rotating speed n is 300 min^{-1} ($n = 300 \text{ min}^{-1}$), effective diameter of pulley D_p is 300 mm ($D_p = 300 \text{ mm}$).

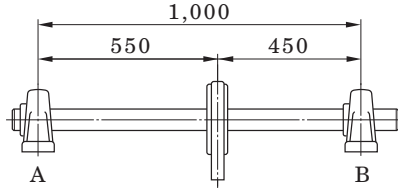

- (1) Find the load actually applied to the pulley shaft F_b with **Formula (5.2)**.

From **Table 5.1**, load factor f_w is 1.2 ($f_w = 1.2$), and the belt factor f_b is 2.5 ($f_b = 2.5$), from **Table 5.2**.

$$F_b = \frac{19.1 \times 10^6 W}{D_p \cdot n} \cdot f_w \cdot f_b$$

$$= \frac{19.1 \times 10^6 \times 7.5}{300 \times 300} \times 1.2 \times 2.5 = 4.78 \text{ (kN)}$$

- (2) Find the load actually applied to the bearing A and bearing B (F_A and F_B) with **Formulas (5.7) and (5.8)**.

$$F_A = \frac{450}{1,000} \times 4.78 = 2.15 \text{ (kN)}$$

$$F_B = \frac{550}{1,000} \times 4.78 = 2.63 \text{ (kN)}$$

Example 3 Calculating dynamic equivalent radial load

Find the dynamic equivalent radial load P_r when the radial load F_r , 1.5 kN ($F_r = 1.5 \text{ kN}$), and the axial load F_a , 0.85 kN, ($F_a = 0.85 \text{ kN}$) are applied to the pillow type unit UCP306J (bearing UC306).

- (1) Find the radial load factor (X) and the axial load factor (Y) with using the static radial load rating C_{0r} of UCP306J (bearing UC306), 15.0 kN ($C_{0r} = 15.0 \text{ kN}$), and **Table 5.4**.

Find the solutions of the following formulas:

$$\frac{f_0 F_a}{C_{0r}} = \frac{13.3 \times 0.85}{15.0} = 0.754, e = 0.264$$

$$\frac{F_a}{F_r} = \frac{0.85}{1.5} = 0.567 > e \text{ (0.264)}$$

Therefore, $X = 0.56, Y = 1.68$

- (2) Find the dynamic equivalent radial load P_r with **Formula (5.9)**.

$$P_r = XF_r + YF_a = 0.56 \times 1.5 + 1.68 \times 0.85$$

$$= 2.27 \text{ (kN)}$$

Example 4 Calculating bearing life

Under the conditions shown in **Example 3**, find the bearing life L_{10h} when a bearing is used for a blower with a rotating speed n , $1,000 \text{ min}^{-1}$.

- (1) Select the load factor f_w is 1.2 ($f_w = 1.2$) from **Table 5.1**, and find the bearing load P_r .

$$P_r = f_w \cdot F = 1.2 \times 2.27 = 2.72 \text{ (kN)}$$

- (2) The dynamic radial load rating of UCP306J (bearing UC306), C_r , is 26.7 kN ($C_r = 26.7 \text{ kN}$), and calculate the bearing life L_{10h} with the **Formula (4.2)**.

$$L_{10h} = \frac{10^6}{60n} \cdot \left(\frac{C_r}{P_r}\right)^3 = \frac{10^6}{60 \times 1,000} \times \left(\frac{26.7}{2.72}\right)^3$$

$$\approx 15,800 \text{ (hr)}$$

- (3) Calculate bearing life L_{10h} with the nomogram shown in **Fig. 4.1**.

When the rotating speed n is $1,000 \text{ min}^{-1}$ ($n = 1,000 \text{ min}^{-1}$), rotating factor f_n is 0.32 ($f_n = 0.32$). Next, find the life factor f_h by speed factor f_n , dynamic radial load rating of bearing C_r , and the bearing load P_r .

$$\text{Life factor } f_h = f_n \cdot \frac{C_r}{P_r} = 0.32 \times \frac{26.7}{2.72} = 3.14$$

From life factor f_h , bearing life $L_{10h} \approx 16,000$ hours.

Example 5 Selecting ball bearing units

If a bearing is operated under the following conditions, select the flange type unit (UCF) with at least two years (5,000 hours) or longer rating life: rotating speed of shaft n is $1,500 \text{ min}^{-1}$ ($n = 1,500 \text{ min}^{-1}$), and radial load F_r is 5 kN ($F_r = 5 \text{ kN}$). The radial load F_r includes the load factor and gear factor.

- (1) From the nomogram shown in **Fig. 4.1**, when life time L_h is 5,000 hr ($L_h = 5,000 \text{ hr}$), life factor f_h can be found as 2.16 ($f_h \approx 2.16$), and speed factor f_n can be found as 0.28 ($f_n \approx 0.28$) when the rotating speed n is $1,500 \text{ min}^{-1}$ ($n = 1,500 \text{ min}^{-1}$).

$$\text{Dynamic radial load rating } C_r = F_r \cdot \frac{f_h}{f_n} = 5 \times \frac{2.16}{0.28}$$

$$\approx 38.6 \text{ (kN)}$$

- (2) Find the flange type unit that meets the following condition: dynamic radial load rating C_r is 38.6 kN ($C_r = 38.6 \text{ kN}$). For the 200 series, UCF211J (dynamic radial load rating C_r is 43.4 kN ($C_r = 43.4 \text{ kN}$)) can be selected.

Example 6 Selecting pillow type units for low speed

If a bearing is used for a dolly under the following conditions, select the pillow type unit (UCP) with 10,000 hours rating life: radial load F_r is 12 kN ($F_r = 12$ kN), and rotating speed is 8 min^{-1} .

- (1) Find the required dynamic radial load rating C_r with using **Formulas (4.4) and (4.5)**.

$$\text{Speed factor } f_n = (0.03n)^{-1/p} = (0.03 \times 8)^{-1/3} \approx 1.61$$

$$\text{Life factor } f_h = \left(\frac{L_{10h}}{500}\right)^{1/p} = \left(\frac{10,000}{500}\right)^{1/3} \approx 2.71$$

$$\begin{aligned} \text{Dynamic radial load rating } C_r &= P_r \cdot \frac{f_h}{f_n} = 12 \times \frac{2.71}{1.61} \\ &\approx 20.2 \text{ (kN)} \end{aligned}$$

- (2) From **Table 5.6**, define safe factor f_s as 2 ($f_s = 2$), and find the static radial load rating of bearing required C_{0r} .

$$C_{0r} = f_s \cdot P_r = 2 \times 12 = 24 \text{ (kN)}$$

- (3) The unit is used for a dolly, and vibration or impact may occur. Thus, select UCP308J ($C_r = 40.7$ kN, $C_{0r} = 24.0$ kN).

Example 7 Calculating bearing life in high temperature applications

Find the bearing life if the heat resistant pillow type unit (UCP215D1K2) is operated under the following conditions: operating temperature is 175°C , radial load F_r is 4 kN ($F_r = 4$ kN), and the rotating speed n is 800 min^{-1} ($n = 800 \text{ min}^{-1}$). Note that the radial load F_r includes load factor and gear factor.

- (1) From **Table 4.1**, find the dynamic load rating C_r in the case that a bearing is used at 175°C .

$$C_r = 67.4 \times 0.95 = 64.0 \text{ (kN)}$$

Find the bearing life L_{10h} using **Formula (4.2)**.

$$\begin{aligned} L_{10h} &= \frac{10^6}{60n} \cdot \left(\frac{C_r}{P_r}\right)^3 = \frac{10^6}{60 \times 800} \times \left(\frac{64.0}{4}\right)^3 \\ &\approx 85,000 \text{ (hr)} \end{aligned}$$

- (2) If a bearing unit is operated at 175°C , grease is degraded faster, and it cannot be used without lubrication. Supply grease at intervals specified in **Table 14.4**.
- (3) If the shaft experiences axial expansion due to heat, install a fixed bearing unit on one end of the assembly and install floating bearing unit on the other side that allows the shaft to move freely through the bore of the bearing. More information is offered in **Section 9**. (see “9 Design of shaft and base”).

Example 8 Calculating grease life

Find the grease life for pillow type unit UCP204J (bearing UC204) under the following conditions: radial load F_r is 1 kN ($F_r = 1$ kN), and rotating speed n is 800 min^{-1} ($n = 800 \text{ min}^{-1}$). Note that the radial load F_r includes load factor and belt factor. Operating temperature of the bearing should be 40°C .

Find the grease life L using **Formula (4.7)**.

$$\begin{aligned} \log L &= 6.10 - 4.40 \times 10^{-6} d_m n - 2.50 \left(\frac{P_r}{C_r} - 0.05\right) \\ &\quad - (0.021 - 1.80 \times 10^{-8} d_m n) T \\ &= 6.10 - 4.40 \times 10^{-6} \times 12.5 \times 10^4 \\ &\quad - 2.50 \left(\frac{1}{12.8} - 0.05\right) \\ &\quad - (0.021 - 1.80 \times 10^{-8} \times 12.5 \times 10^4) \times 50 \\ &= 4.542 \\ L &\approx 34,800 \text{ (hr)} \end{aligned}$$

Example 9 Calculating life of bearing units in case of non-lubrication

Find the life of a bearing unit in the case that it is operated under the conditions shown in **Example 8**, but without lubrication.

- (1) Find the rating life of bearings L_{10h} using **Formula (4.2)**.

$$\begin{aligned} L_{10h} &= \frac{10^6}{60n} \cdot \left(\frac{C_r}{P_r}\right)^3 = \frac{10^6}{60 \times 800} \times \left(\frac{12.8}{1}\right)^3 \\ &\approx 43,700 \text{ (hr)} \end{aligned}$$

- (2) Compare the grease life L shown in **Example 8** to the rating life of bearings L_h . Then, grease life L is shorter than the bearing rating life. Therefore, life of a bearing unit should be the same as the grease life L , 34,800 hours ($L = 34,800$ hours).

6 Allowable Rotating Speed

6.1 Allowable Rotating Speed

The rotational speed of a bearing is limited by the temperature increase, mainly due to friction. When the bearing reaches the speed limits shown below, it will seize if operated continuously at these levels.

The limiting rotational speed is the maximum speed at which the bearing can be safely operated continuously.

These allowable rotational speeds of a ball bearing unit are dependent upon the dimensions of the bearing, type of seal, and the fit of the bearing inner ring to the shaft.

Table 6.1 shows the standard allowable rotating speeds of ball bearing units.

Table 6.1 Allowable rotating speed of ball bearing units (standard value)

Unit: min⁻¹

Bore dia. code	UC type bearing, UC-S6 type bearing, UK type bearing, NC type bearing, NA type bearing, ER, RB type bearing									SA type bearing SB type bearing	SU type bearing SU-S6 type bearing
	Standard type, heat resistant (D1K2), cold resistant type (D2K2) Standard blowers (S3), Heat-resistant (D9K2)			Triple lip seal type (L3)			Non contact seal (K3), Non contact seal for blowers (S5)				
	Diameter series ³⁾			Diameter series ³⁾			Diameter series ³⁾			Diameter series ³⁾	Diameter series ³⁾
	2	X	3	2	X	3	2	X	3	2	0
8											10,000
00	–			–			–			–	10,000
01	5,800			2,300			8,700			6,800	8,000
02	5,800			2,300			8,700			6,800	6,600
03	5,800			2,300			8,700			6,800	5,800
04	5,800	–	–	2,300	–		8,700	–	–	5,800	5,000
05	5,100	4,300	4,600	2,100	960		7,700	6,400	6,700	5,100	4,000
06	4,300	3,700	3,900	960	830	–	6,400	5,500	5,800	4,300	3,300
07	3,700	3,300	3,400	830	750	770	5,500	5,000	5,100	3,700	–
08	3,300	3,100	3,100	750	690	690	5,000	4,600	4,600	3,300	
09	3,100	2,800	2,700	690	640	620	4,600	4,300	4,100	3,100	
10	2,800	2,500	2,400	640	570	550	4,300	3,800	3,700	2,800	
11	2,500	2,300	2,300	570	520	510	3,800	3,500	3,400		
12	2,300	2,200	2,100	520	490	470	3,500	3,200	3,100		
13	2,200	2,100	1,900	490	460	440	3,200	3,100	2,900		
14	2,100	2,000	1,800	460	440	410	3,100	2,900	2,700		
15	2,000	1,800	1,700	440	410	380	2,900	2,700	2,600		
16	1,800	1,700	1,600	410	380	360	2,700	2,600	2,400		
17	1,700	1,600	1,500	380	360	340	2,600	2,400	2,300		
18	1,600	1,500	1,400	360	340	320	2,400	2,300	2,100		
19	–	–	1,400	–	–	310	–	–	2,000		
20		1,300	1,300		300	280		2,000	1,900		
21		–	1,200		–	–		–	1,800		
22			1,100			250			1,700		
24			1,100			240			1,600		
26			1,000			220			1,500		
28			910			200			1,400		

Remarks 1. Allowable rotating speed of the units with covers is 80% of the value shown in the table above.

2. If a bearing unit is used with an excessively loose fit, allowable rotating speed must be corrected by multiplying it by the fitting factor f_c shown in **Table 6.2**.

3. The basic bearing size number consists of the duty code (2, X, or 3) followed by the inner ring size code (07, 10, 24, etc.)

6.2 Rotational Speed Adjustment Due to Shaft Fit

A marginal degree of clearance is typically used to facilitate easy installation of a bearing to a shaft. The amount of clearance between the bearing and shaft must be factored in to determine the maximum allowable rotational speed, and as rotational speed is increased, the amount of clearance must be decreased.

Table 6.2 shows the factor that must be used to correct the allowable rotational speed. The maximum rotational speed is determined by multiplying the speed found in Table 6.1 by the factors below. This table includes the multiplying factors for set screw bearings as well as bearings with adapters and eccentric locking collars. Due to the characteristics of bearings with adapters, a loose fit, h8 or h9, is acceptable. Bearings with eccentric locking collars function optimally with less clearance and therefore, an h5 or j5 fit is recommended to achieve the maximum allowable speed.

Table 6.2 Fitting factor of ball bearing units f_c (recommended)

Type of ball bearing units	Fitting factor f_c					
	Shaft tolerance range class					
	h5, j5	j6	h6	h7	h8	h9
With set screws						
Standard type	–	1	1	0.8	0.5	0.2
L III type (Suffix code: L3)	–	–	–	1	1	0.9
Heat resistant type (Suffix code: D1K2)	–	–	–	1	1	0.7
Cold resistant type (Suffix code: D2K2)	–	–	–	1	1	0.7
For high speed (Suffix code: K3)	–	1	0.8	0.6	–	–
For blower (Suffix code: S3 · S5)	1	–	0.8	0.6	–	–
With adapters	–	–	–	–	1	1
With eccentric locking collar	1	–	–	–	–	–
NU concentric locking collar						

7 Operating Temperature and Bearing Specifications

7.1 Operating Temperature Range

The operating temperature of a ball bearing unit depends on the type of grease, the material of the seal, and the internal clearance of the bearing.

FYH Ball Bearing Units are available in high temperature (D1K2, D9K2) and low temperature (D2K2) series, in addition to the standard models, to allow selection of the correct bearing for your operational temperature (see Table 2.1).

The correct unit must be chosen for the desired temperature range, and it is equally important to use the appropriate grease according to the specified schedule.

7.2 Operating Temperature and Internal Clearance of Bearings

When bearings are operated in a high ambient temperature environment, or when the operating temperature is high because of rotational speed, differential expansion rates occur within the bearing components. This causes higher friction, grease breakdown, and eventual seizure.

If the temperature difference between the inner and outer ring is known, or can be approximated, then the following **Formula (7.1)** may be applied.

Under these conditions, decrease in the internal clearance must be calculated, and the internal clearance of bearing needs to be selected properly.

$$S_{t1} = \alpha \cdot D_e \cdot \Delta_t \dots\dots\dots (7.1)$$

Whereas,

S_{t1} : Decrease in the internal clearance of bearings depending on the difference in the temperatures of the bearing inner ring and the bearing outer ring can be found by formula, mm

α : Line expansion factor of bearing steel, 12.5×10^{-6}

D_e : Raceway dia. of bearing outer ring, mm
 Diameter series 2, X..... $D_e \approx 0.92 D$
 Diameter series 3..... $D_e \approx 0.9 D$

D : Nominal bearing outer dia., mm

Δ_t : Difference in temperatures of bearing inner ring and outer ring, °C

If a ball bearing unit is used in a high temperature environment, an abnormal load will result due to thermal expansion of the shaft. This must be compensated for by allowing free movement of one side of the shaft.

(See “9 Design of Shaft and Base”)

8 Strength of Housings

FYH bearings can withstand very high loads due to the use of only high quality material and excellent design. However, when high static or impact loads are encountered, the load capacity of the bearing must be determined.

The housing design is such that it can withstand loads from any angle; however the bearing is strongest with a direct downward load through the base of the unit. For loads in other directions, the allowable load must be determined specifically for the direction in question.

Rigidity of the base and flatness of the mounting surface also influence the housing strength. The equipment designer or installer must examine and perform calculations for the complete supporting structure of the bearing.

8.1 Strength of Cast Iron Housings

Although gray cast iron has many superior characteristics, it may fail under impact loads, particularly in a low temperature environment.

Table 8.1 shows the applicable design safety factors for gray cast iron. Fig. 8.1 to 8.7 show the static rupture strength of the various housing types.

Table 8.1 Safety factor of gray cast iron products (recommended)

Property of load	Safety factor of gray cast iron
Static load	4
With vibration	10
With impact	15

8.2 Strength of Ductile Cast Iron Housings

The high-strength ductile cast iron series has the same shape and dimensions as the standard gray cast iron series, but is acceptable in environments where high-strength is required.

Table 8.2 shows safety factors of the load on ductile cast iron housings, and tables 8.8 to 8.11 show the approximate rupture strength of pillow type, flange type, and take-up type housings.

Table 8.2 Safety factor of ductile cast iron (recommended)

Property of load	Safety factor of ductile cast iron
Static load	3
With vibration	5
With impact	10

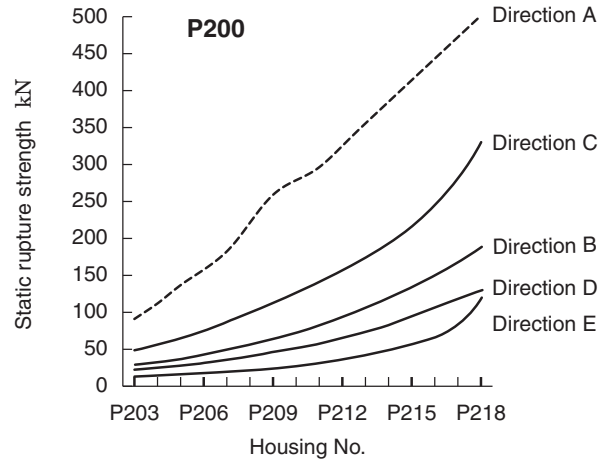
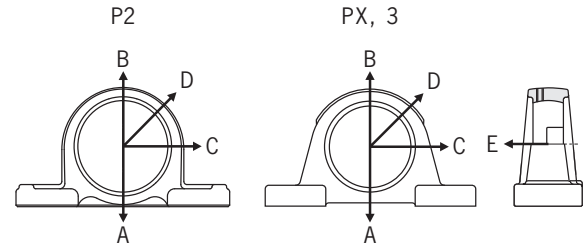

Remarks The graph value "Direction of A" is a reference value.

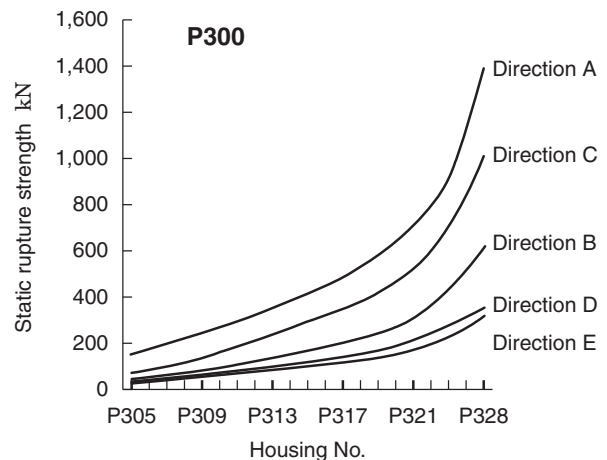
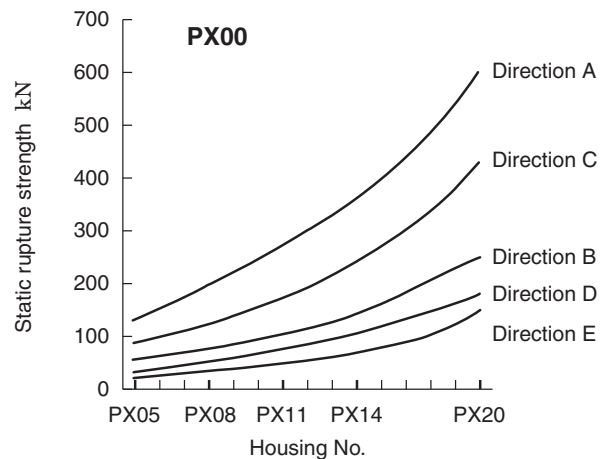

Fig. 8.1 Static rupture strength of pillow type housing (P)

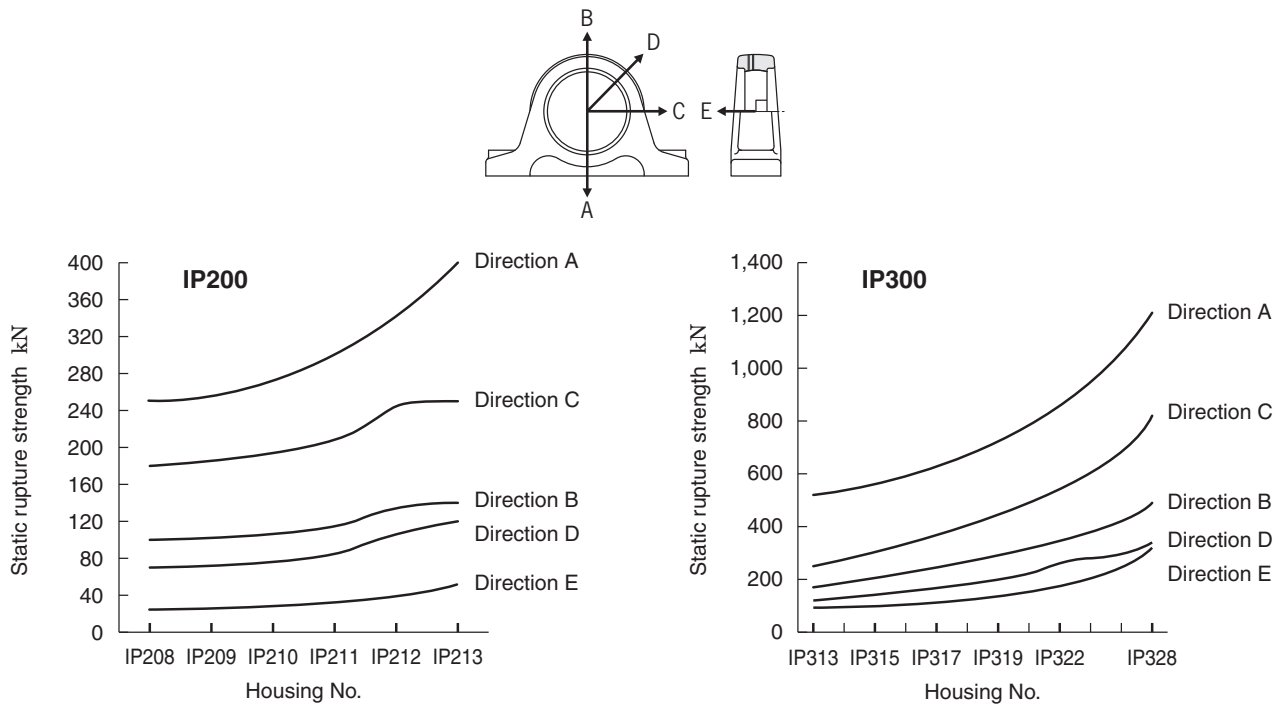

Fig. 8.2 Static rupture strength of thick pillow type housings (IP)

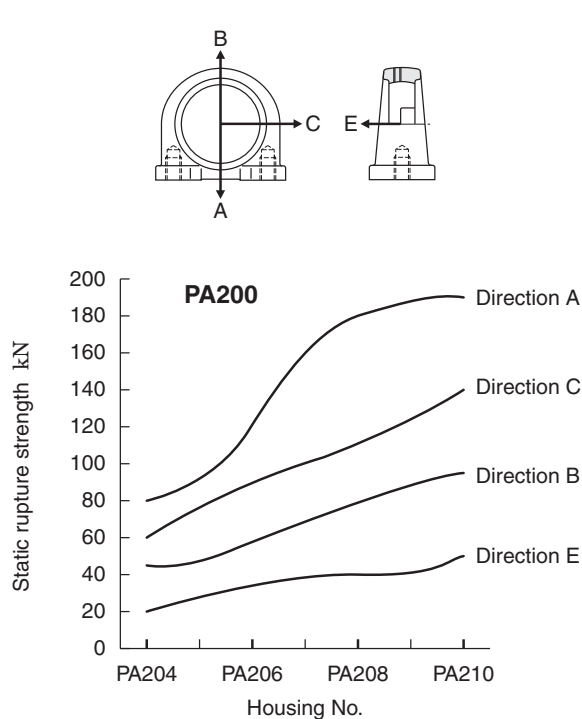

Fig. 8.3 Static rupture strength of tapped base pillow type housings (PA)

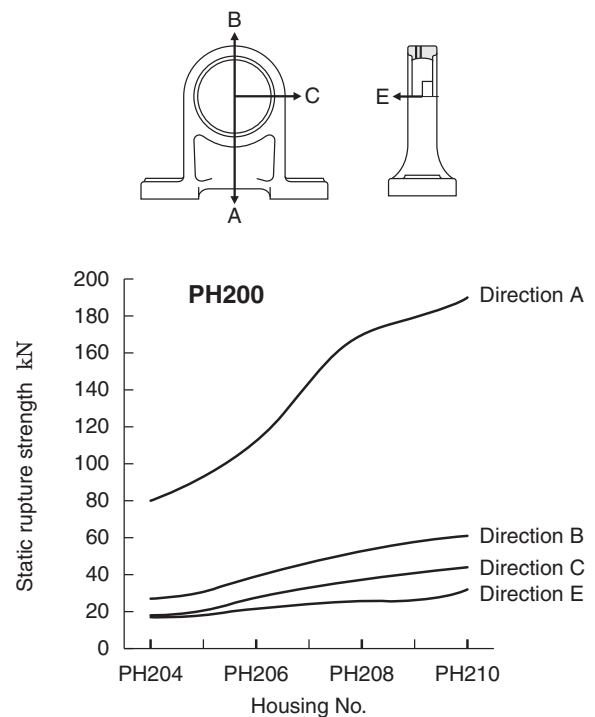

Fig. 8.4 Static rupture strength of High-Base pillow type housings (PH)

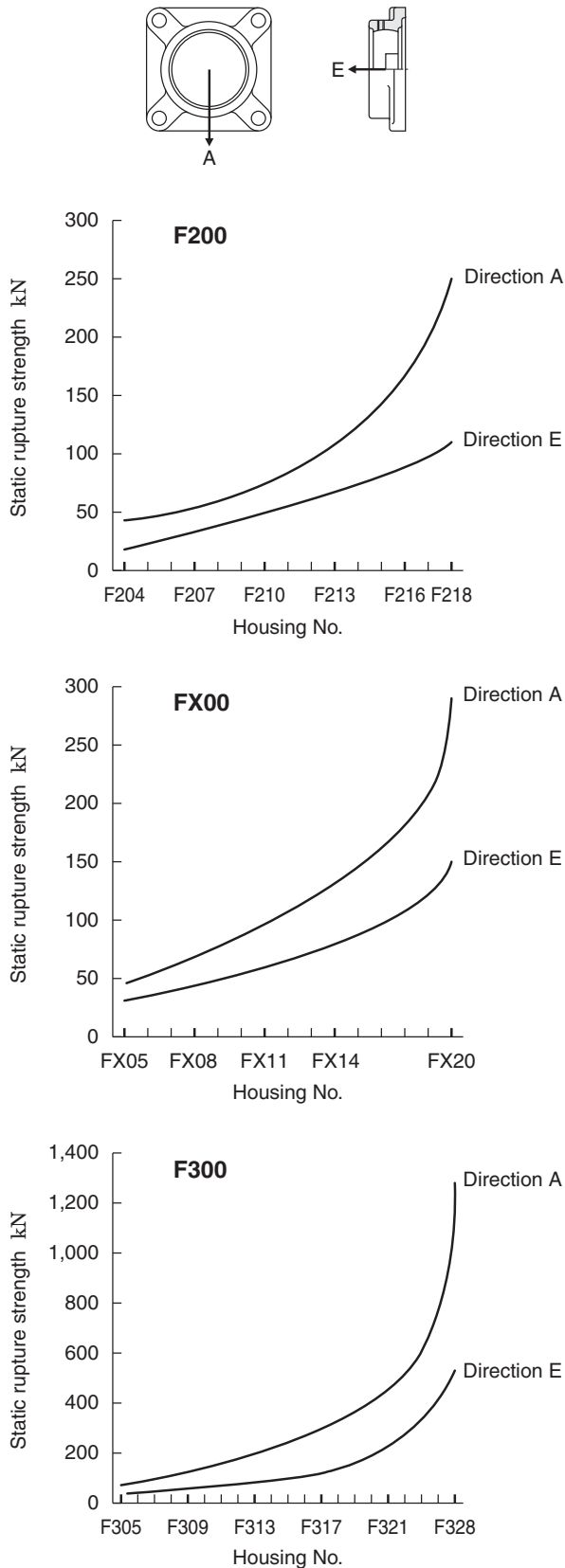

Fig. 8.5 Static rupture strength of square flange type housings (F)

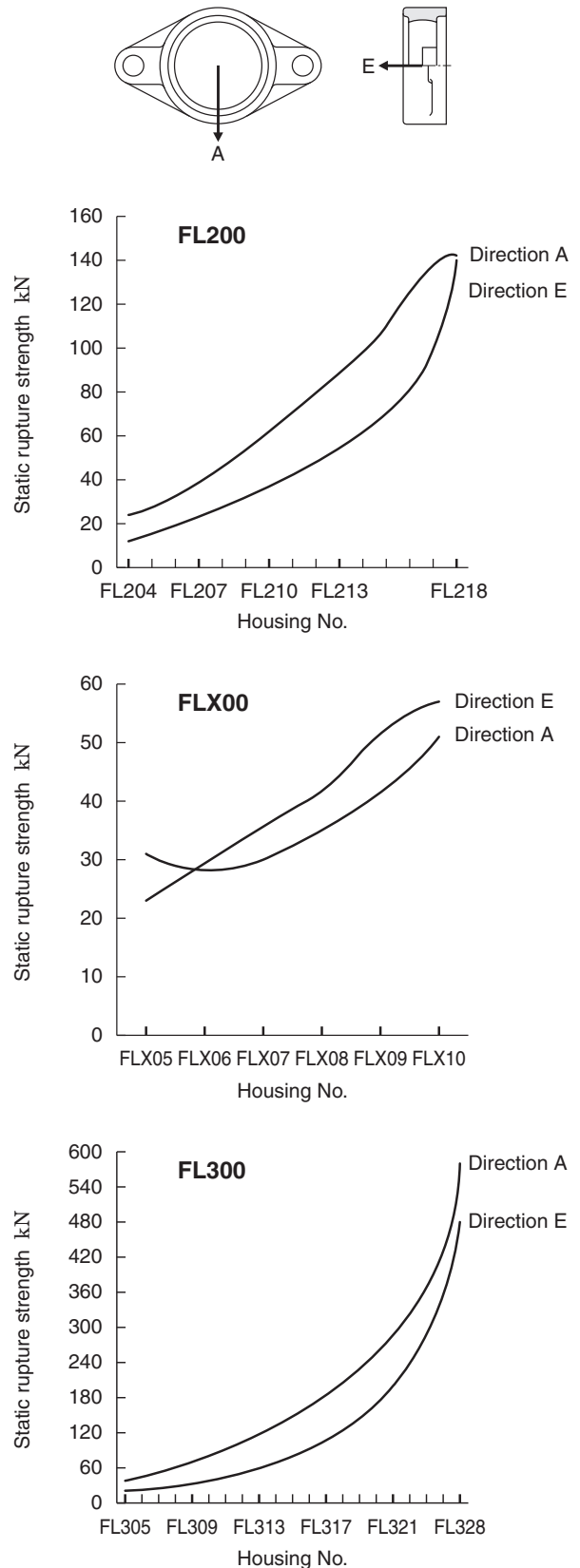

Fig. 8.6 Static rupture strength of oval flange type housings (FL)

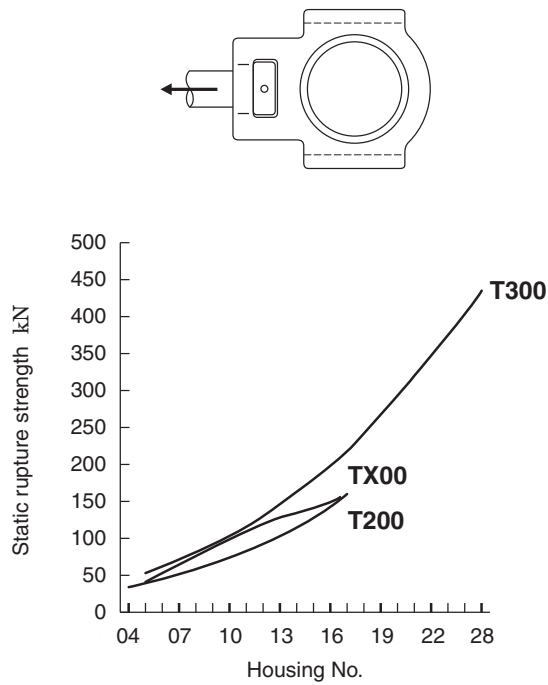

Fig. 8.7 Static rupture strength of take-up type housings (T)

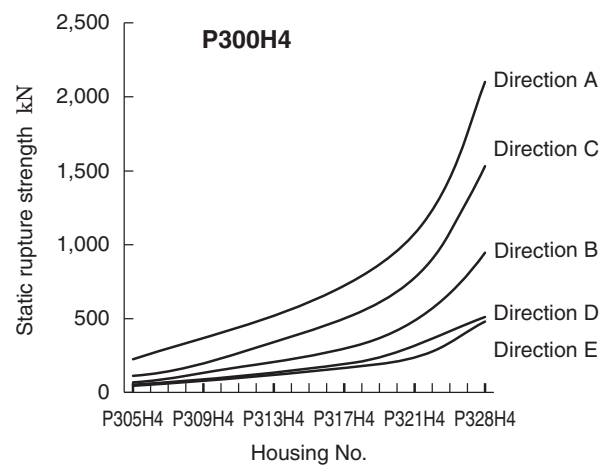
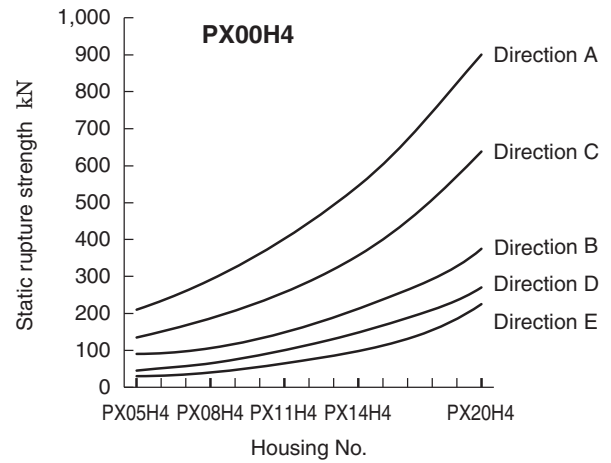
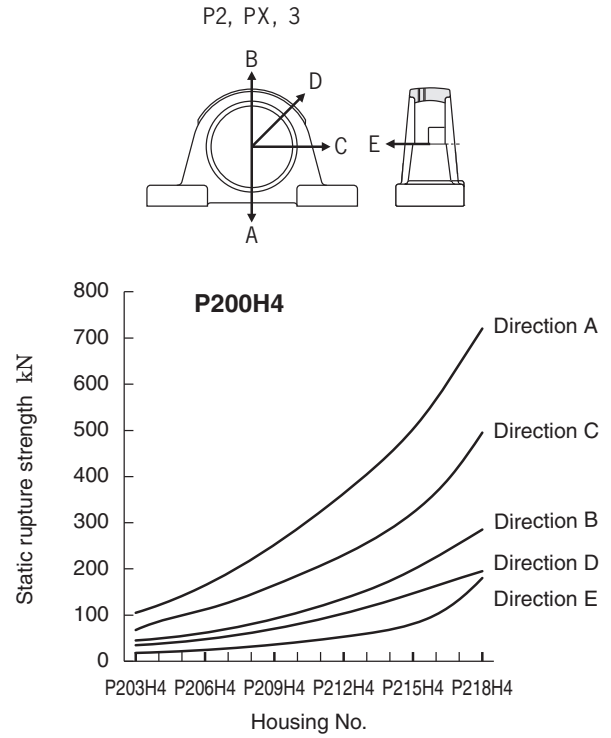

Fig. 8.8 Static rupture strength of ductile cast iron pillow type housings (PH4)

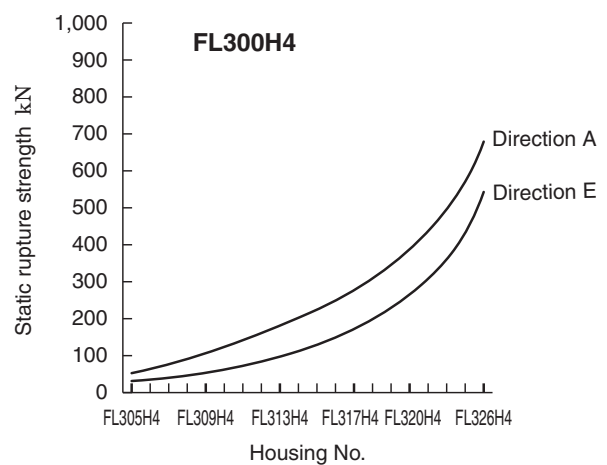
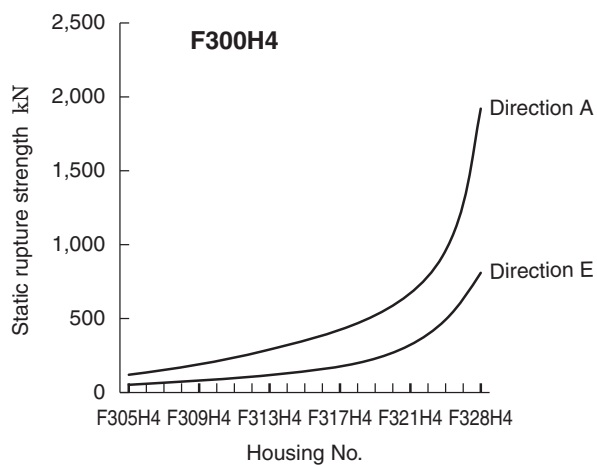
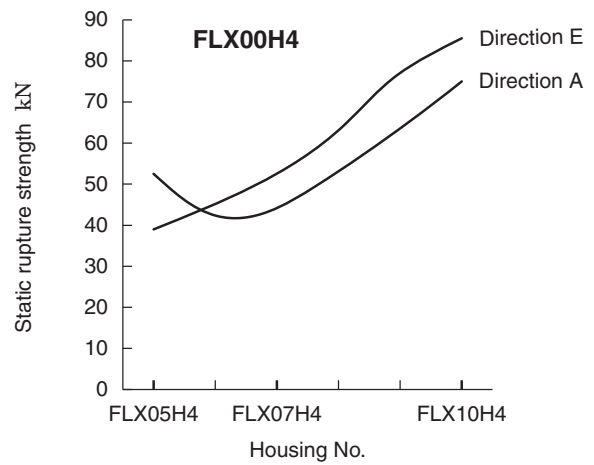
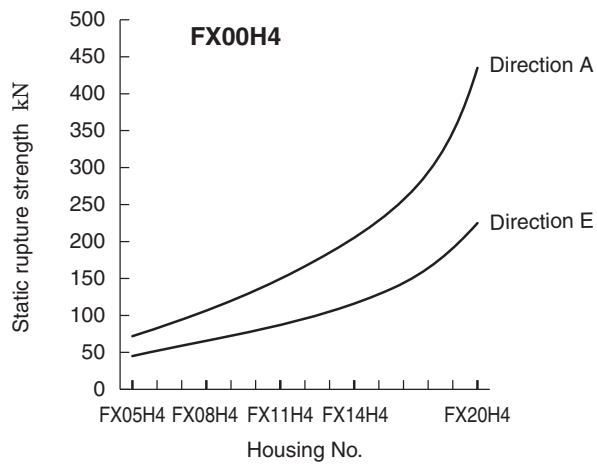
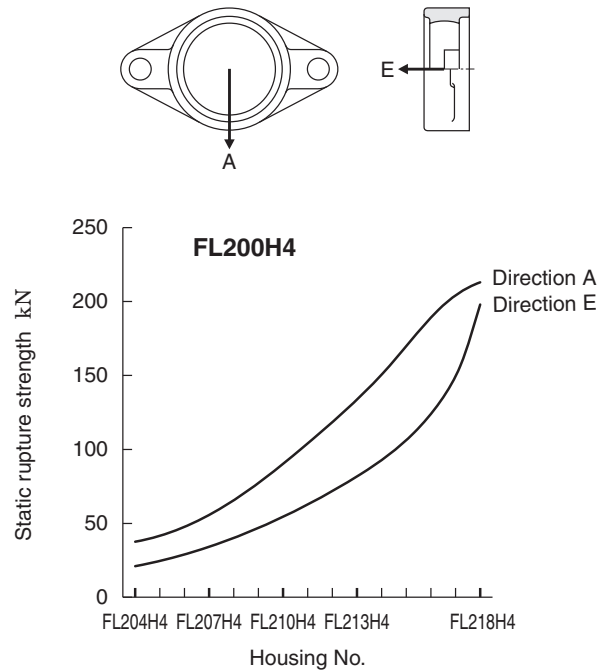
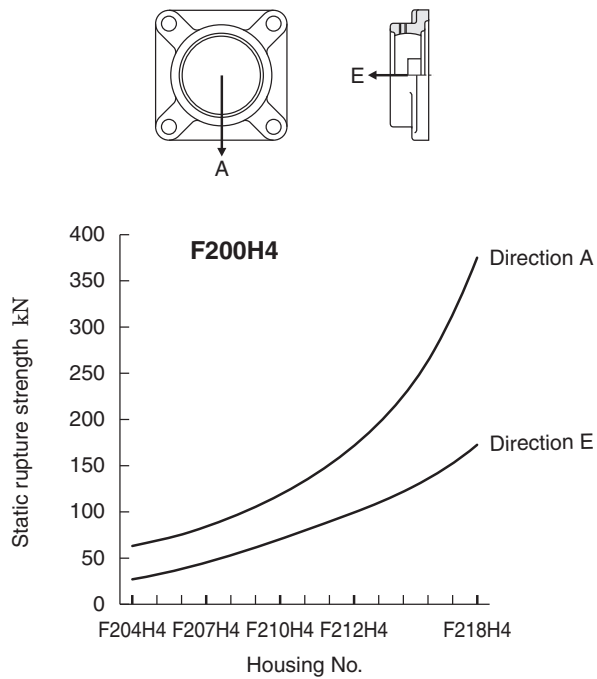

Fig. 8.9 Static rupture strength of ductile cast iron square flange type housings (FH4)

Fig. 8.10 Static rupture strength of ductile cast iron oval flange type housings (FLH4)

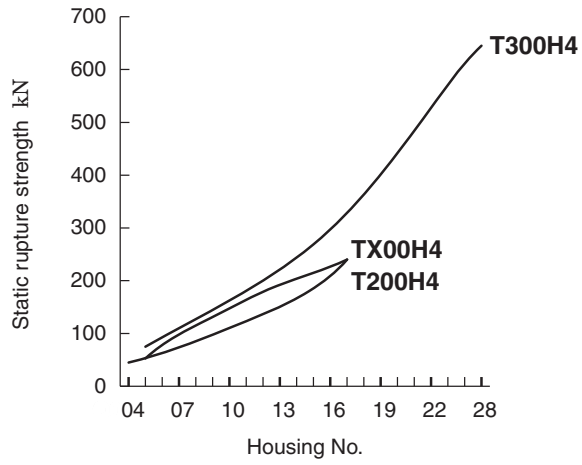
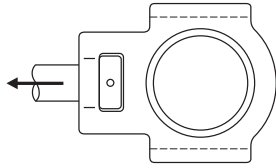

Fig. 8.11 Static rupture strength of ductile cast iron take-up type housings (TH4)

8.3 Strength of Stamped Steel Housings

The precisely formed stamped steel housing is very rigid, but it is not as strong as cast iron or cast steel housings. Therefore, it will not support loads to the maximum rating of the bearing itself and must be down-rated per **Table 8.3**.

Table 8.3 Allowable load of steel plate housings (recommended)

Load direction	Allowable load of stamped steel housings
Radial	Approx. 1/6 of basic dynamic radial load rating of bearing (C_r)
Axial	Approx. 1/18 of basic dynamic radial load rating of bearing (C_r)

8.4 Strength of Stainless Steel Housings

FYH supplies stainless steel housings (SP-H1, SPA-H1, SF-H1, SFL-H1, ST-H1, SP, SFL).

Table 8.4 shows the safety factors for stainless steel products. As for the basic values of the static rupture strength of SP-H1, SPA-H1, SF-H1, SFL-H1, ST-H1, SFC-H1 type housings, apply P200 of **Fig. 8.1**, PA200 of **Fig. 8.3**, F200 of **Fig. 8.5**, FL200 of **Fig. 8.6** and T200 of **Fig. 8.7**. As for the basic values of the static rupture strength of SFC-H1 housings, apply F200 of **Fig. 8.5**. For the basic values of the static rupture strength of the SP and SFL type housings, see P000~P006 of **Fig. 8.12** and FL000~FL006 of **Fig. 8.13** and multiply them by 1.5 respectively.

Table 8.4 Safety factor of stainless steel products

Property of load	Safety factor of stainless steel products
Static load	3
With vibration	5
With impact	10

8.5 Strength of Die-cast Housings

The clean series housing is made of die-cast zinc alloy, but the zinc alloy material is not as strong as cast iron or cast steel. **Table 8.5** shows safety factors for die-cast zinc alloy, and **Fig. 8.12** and **8.13** show the basic values of the static rupture strength of the die-cast zinc alloy housing.

Table 8.5 Safety factor of zinc alloy die-cast products

Property of load	Safety factor of die-cast products
Static load	8
With vibration	15
With impact	20

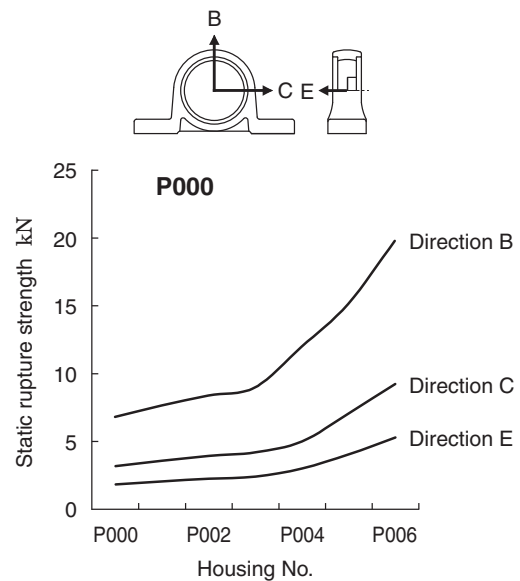

Fig. 8.12 Static rupture strength of clean housings (P)

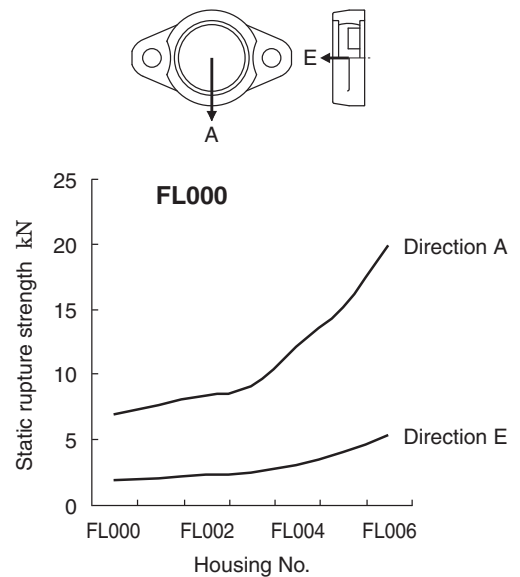

Fig. 8.13 Static rupture strength of clean housings (FL)

8.6 Static Rupture Strength of Plastic Housings

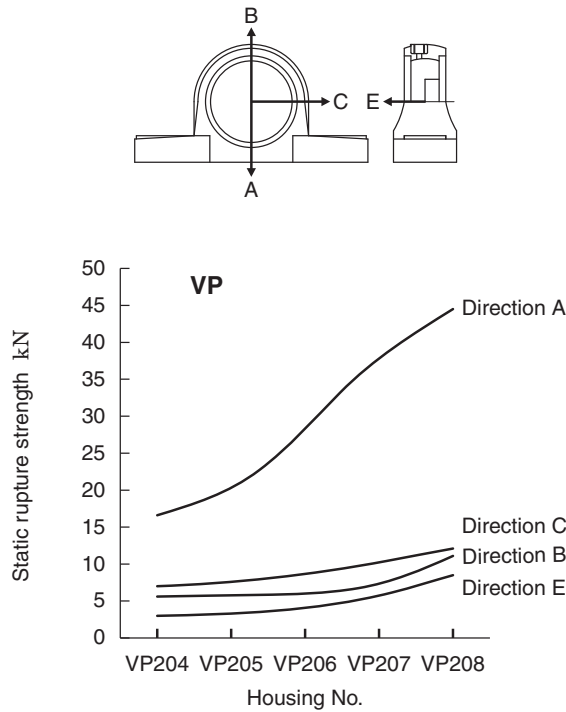

Fig. 8.14 Static rupture strength of plastic housings (VP)

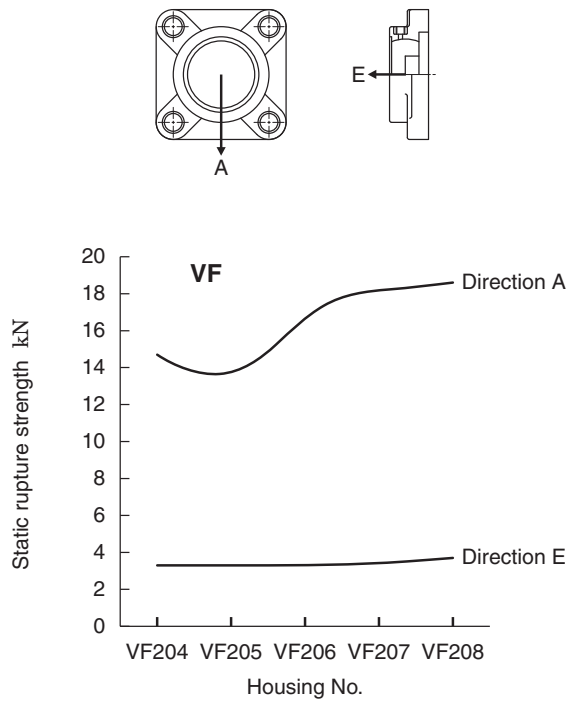

Fig. 8.15 Static rupture strength of plastic housings (VF)

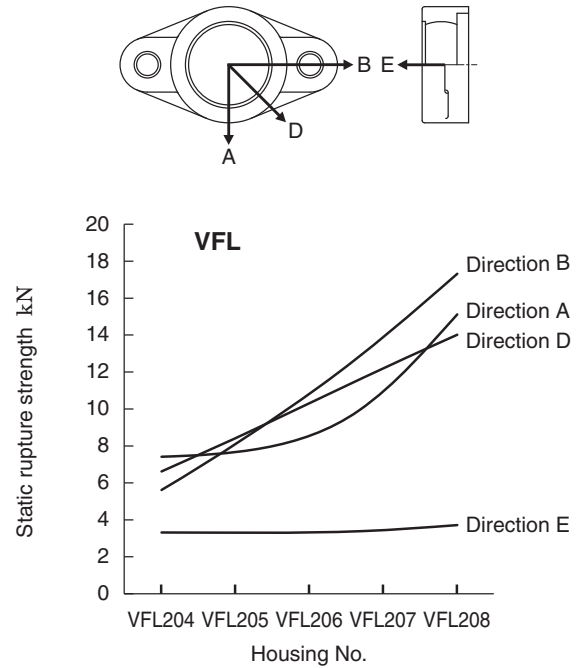

Fig 8.16 Static rupture strength of plastic housings (VFL)

Note:

The figure shows the average static rupture strength of housings.

The correct safety factor should be considered to properly account for combined load in various directions at room temperature (23 °C ±5 °C).

9 Design of Shaft and Base

9.1 Design of Shaft

For optimal performance of a ball bearing unit, and for maintenance-free operation for an extended period of time, proper shaft selection is very important. The shaft should be straight, of sufficient tensile strength, and free of burrs and scratches.

9.1.1 Dimensional accuracy of shaft

(1) Dimensional tolerance of shaft used for set screw bearings

For bearings with set screws, a relatively looser class of fit makes assembly easier and is perfectly acceptable

at low operating speeds. The clearance between the bore of the bearing and the shaft must be decreased as the rotational speed is increased.

Table 9.1 shows the guidelines for the tolerance class for the rotational speed of bearings with set screws.

If the bearing with set screws is exposed to a heavy load ($P_r/C_r > 0.12$), vibration, or heavy impact, use a tighter shaft tolerance than normal.

Table 9.2 shows the tolerances for tight fits.

Table 9.3 shows the recommended roundness and cylindricity for shafting.

Table 9.1 Dimensional tolerance of shaft used for cylindrical bore bearing with set screws (recommended) (clearance fit or intermediate fit)

Unit: μm

Shaft dia. (mm)		Dimensional tolerance of shaft							
		j6		h6		h7		h8	
Over	Incl.	Max.	Min.	Max.	Min.	Max.	Min.	Max.	Min.
6	10	+ 7	- 2	0	- 9	0	-15	0	-22
10	18	+ 8	- 3	0	-11	0	-18	0	-27
18	30	+ 9	- 4	0	-13	0	-21	0	-33
30	50	+11	- 5	0	-16	0	-25	0	-39
50	80	+12	- 7	0	-19	0	-30	0	-46
80	120	+13	- 9	0	-22	0	-35	0	-54
120	180	+14	-11	0	-25	0	-40	0	-63
Applicable rotating speed dn^1		Over 120,000		Over 100,000, incl. 120,000		Over 60,000, incl. 100,000		Incl. 60,000	

Note ¹ $dn = d$ (bearing bore dia., mm) $\times n$ (rotating speed, min^{-1})

Table 9.2 Dimensional tolerance of shaft used for cylindrical bore bearing with set screws (recommended) (intermediate fitting or tight fitting)

Unit: μm

Shaft dia. (mm)		Dimensional tolerance of shaft					
		k6		k7		m6	
Over	Incl.	Max.	Min.	Max.	Min.	Max.	Min.
6	10	+10	+1	+16	+1	+15	+ 6
10	18	+12	+1	+19	+1	+18	+ 7
18	30	+15	+2	+23	+2	+21	+ 8
30	50	+18	+2	+27	+2	+25	+ 9
50	80	+21	+2	+32	+2	+30	+11
80	120	+25	+3	+38	+3	+35	+13
120	180	+28	+3	+43	+3	+40	+15

Table 9.3 Recommended accuracy of shaft used for ball bearing units

Unit: μm

Shaft dia. (mm)		Tolerance of shaft roundness and cylindricity (max.)
Over	Incl.	
6	10	6
10	18	8
18	30	9
30	50	11
50	80	13
80	120	15
120	180	18

(2) Dimensional tolerance of shaft used with tapered bore bearings

Since tapered bore bearings are fixed to the shaft with an adapter, a looser fit is allowable since the adapter sleeve provides excellent concentricity. This makes mounting of the bearing to the shaft much easier.

Table 9.4 shows the dimensional tolerance of the shaft used with tapered bore bearings (with adapters).

Table 9.4 Dimensional tolerance of shaft used for tapered bore bearings (with adapters) (recommended)

Unit: μm

Shaft dia. (mm)		Dimensional tolerance of shaft			
		h8		h9	
Over	Incl.	Max.	Min.	Max.	Min.
18	30	0	-33	0	- 52
30	50	0	-39	0	- 62
50	80	0	-46	0	- 74
80	120	0	-54	0	- 87
120	180	0	-63	0	-100

(3) Dimensional tolerance of shaft with eccentric locking collar

Eccentric locking collar bearings have greater clearance (more eccentricity) between the shaft and the bore of the bearing when installed. Therefore, the shaft tolerances must be tighter (h5 or j5) to reduce the clearance (eccentricity). The same clearance fits are recommended as with blower bearings as shown in Table 2.6.

(4) Dimensional tolerance of shaft used for concentric locking collar

Regarding the shaft used for concentric locking collar bearings, the same clearance (h5 or j5) fits are recommended as with air handling bearings as shown in Table 2.6.

9.1.2 Dimensions of shouldered shafts

When using a set screw or eccentric locking collar bearing that is exposed to a high axial load, excessive vibration, or impact, a shouldered shaft may be used. The inner ring of the bearing is then tightened in place with a locknut, if the shaft is threaded, or with a locking ring otherwise.

However, if after mounted units used a shouldered shafts, between the inner ring end face and shouldered shafts, on clearances of 2 mm or more is recommended.

Table 9.5 shows the shoulder diameter and the fillet radius of the shouldered shaft.

Table 9.5 Recommended shoulder diameter and fillet radius of a shouldered shaft

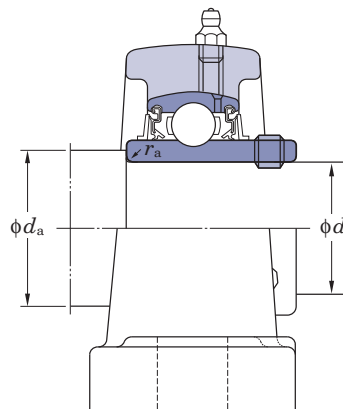

Unit: mm

Bore dia. code	Nominal bearing bore dia. d	Diameter Series ¹⁾		Diameter Series ¹⁾	
		UC200, UCX00		UC300	
		Shoulder dia. d_a	Fillet roundness radius r_a (max.)	Shoulder dia. d_a	Fillet roundness radius r_a (max.)
01	12	17	0.6		
02	15	20	0.6		
03	17	22	0.6		
04	20	30	1	-	-
05	25	35	1	35	1
06	30	40	1	40	1
07	35	45	1	45	1.5
08	40	50	1	50	1.5
09	45	55	1	55	1.5
10	50	60	1	60	2
11	55	65	1.5	65	2
12	60	70	1.5	75	2
13	65	75	1.5	80	2
14	70	80	1.5	85	2
15	75	85	1.5	90	2
16	80	90	2	95	2
17	85	95	2	100	2.5
18	90	100	2	105	2.5
19	95	-	-	110	2.5
20	100			115	2.5
21	105			120	2.5
22	110			125	2.5
24	120			135	2.5
26	130			150	3
28	140			160	3

The basic bearing size number consists of the duty code (2, X, or 3) followed by the inner ring size code (07, 10, 24, etc.)

9.1.3 High temperature applications

In general, two bearing units are used per shaft. If the distance between the bearings is small, or if the temperature change of the shaft is small, both bearings may be fixed in position.

However, if the distance between the bearings is large and the shaft is exposed to heat, then only one bearing should be fixed and the opposing bearing must be free to float in the axial direction.

This is because shaft expansion due to temperature change of the shaft causes a high axial load and can cause failure of fixed bearings. The amount of shaft expansion due to temperature change may be calculated by using **Formula (9.1)**.

$$\Delta l = \alpha \cdot \Delta t \cdot l \dots\dots\dots (9.1)$$

Whereas,

- Δl : Expansion of shaft, mm
- α : Linear expansion coefficient of shaft
in the case of ordinary steel, $11\sim 12 \times 10^{-6}$
- Δt : Temperature increase, °C
- l : Installation distance of unit, mm

Proper installation procedures for a shaft exposed to temperature changes are shown below.

(1) Installation with a dog point set screw on the free side

To accommodate shaft expansion in the axial direction, the bearing must be installed so that the shaft can move freely through the bore in either axial direction.

To accomplish this, the shaft must be grooved for a full dog point set screw (suffix code: G6). This should be done on the free side only. The dog point screw allows free movement in the axial direction and provides force to rotate the bearing in the radial direction.

Fig. 9.1 shows an example of the structure of a bearing with a key groove on the shaft and a full dog point set screw. **Table 9.6** shows the dimensions of the key groove for the full dog point set screw. Note that the full dog point set screw in the image is also capped so that it may be tightened against the bearing, not the shaft. A full dog point set screw with a jam nut will also work to achieve this function.

The tolerance class of the shaft to be used is h7.

If the temperature of the shaft is higher than that of the bearing, then a looser fit tolerance class is specified.

When using this method to allow for free expansion, there is the possibility of fretting between the shaft and the inner race. In order to prevent fretting, a high temperature grease must be applied to the inner ring of the bearing and the shaft prior to installation.

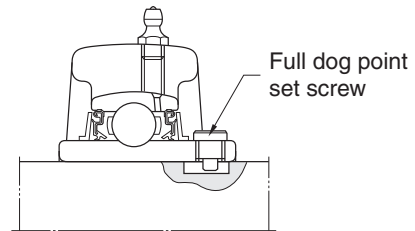
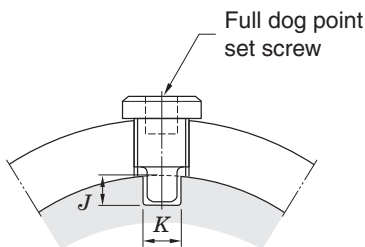

Fig. 9.1 Use on free side with full dog point set screw

Table 9.6 Dimensions of key groove for full dog point set screw (use on free side)

Nominal size of set screw	Dimensions of key groove (mm)		Applicable nominal bearing code		
	J	K	UC200	UCX00	UC300
M6 × 0.75	5	4	201-206	X05	305, 306
M8 × 1	6	6	207-209	X06-X08	307
M10 × 1.25	6.5	7	210-212	X09-X11	308, 309
M12 × 1.5	7	9	213-218	X12-X17	310-314
M14 × 1.5	7	10		X18	315, 316
M16 × 1.5	8	12		X20	317-319
M18 × 1.5	8	13			320-324
M20 × 1.5	8	15			326, 328



Allowable tolerance of key groove dimension “K” (Recommended value: 0~+0.2mm)

(2) Installation of cartridge type units on the free side

If the rotational speed is high or if the bearing is exposed to high vibration, the cartridge type unit is recommended on the free side. In this case, the housing of the cartridge unit is free to move axially within the mounting bore and the bearing insert is rigidly attached to the shaft.

Fig. 9.2 shows the required structure for the cartridge type unit on the free side.

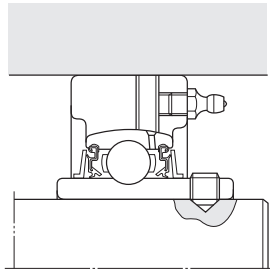

Fig. 9.2 Use of cartridge type units on free side

If, in addition to the expansion of the shaft, the ball bearing itself is exposed to heat, then a calculation of the decrease in internal clearances of the bearing must be made. The appropriate bearing internal clearance must be specified. (see “7 Operating temperature and bearing specifications”).

9.2 Mounting Base Design

9.2.1 Rigidity of base and flatness of mounting Surface

If rigidity of the base on which a ball bearing unit is to be mounted is not sufficient, or if the flatness of the mounting surface is poor, then vibration or abnormal noise may occur during operation. This may lead to premature bearing failure since the strength of the housing is diminished from improper support.

The mounting surface must be accurately machined to eliminate deformation of the housing.

Fig. 9.3 shows the recommended values for flatness of the mounting surface on which the ball bearing unit is to be installed.

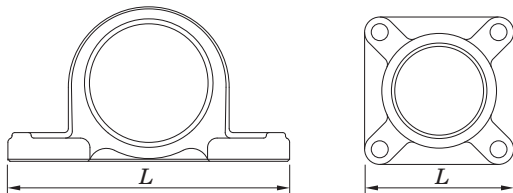

Max.: $L / 1,000$ mm

Fig. 9.3 Flatness of mounting surface of base (recommended value)

9.2.2 Mounting cartridge type units in high temperature applications

Cartridge units are designed to fit into an accurately bored cylindrical opening in the mounting base. Under ordinary operating conditions, H7 is an adequate choice for the tolerance class of the cylindrically bored hole.

In instances where both the bearing and the shaft are heated during operation, select G7 as the tolerance class of the cylindrical bore.

If the bearing is exposed to excessive vibration or impact, then an even tighter tolerance class must be specified.

Table 9.7 shows the dimensional requirements for the cylindrical bore.

Table 9.7 Dimensional tolerance of cylindrical bore for mounting cartridge type units (recommended values)

Unit: μm

Nominal bore dia. of cylindrical bore (mm)		Dimensional tolerance of cylindrical bore			
		H7		G7	
Over	Incl.	Max.	Min.	Max.	Min.
50	80	+30	0	+40	+10
80	120	+35	0	+47	+12
120	180	+40	0	+54	+14
180	250	+46	0	+61	+15
250	315	+52	0	+69	+17
315	400	+57	0	+75	+18

9.2.3 Installation of take-up units

A take-up unit is positioned between two guide rails and enables linear adjustment by means of the threaded rod and bolt.

Table 9.8 shows the dimensions of the guide rail, adjuster bolt, and fixed nut.

Table 9.8 Dimensions relative to installation of take-up type units (recommended values)

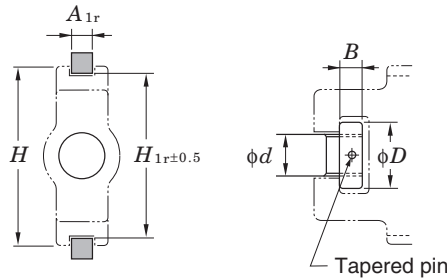

Unit: mm

Nominal bearing code	Dimensions of guide rail			Dimensions of adjuster bolt and round nut		
	A_{1r}	H_{1r}	H (Reference)	d	D	B
T204 T205	11	77	89	16	28	14
T206 T207	11	90	102	18	32	14
T208	15	103	114	24	42	16
T209 T210	15	103	117	24	42	16
T211 T212	20	131	146	30	55	20 27
T213 T214 T215	24	152	167	36	60	27
T216	24	166	184	36	60	27
T217	28	174	198	42	60	30
TX05 TX06	11	90	102	18	32	14
TX07	15	103	114	24	42	16
TX08 TX09	15	103	117	24	42	16
TX10 TX11	20	131	146	30	55	20 27
TX12 TX13 TX14	24	152	167	36	60	27
TX15	26	166	184	36	60	27
TX16 TX17	26	174	198	42	60	30

Remark This table is also applicable to stainless steel housings.

Unit: mm

Nominal bearing code	Dimensions of guide rail			Dimensions of adjuster bolt and round nut		
	A_{1r}	H_{1r}	H (Reference)	d	D	B
T305	11	81	89	22	32	12
T306 T307	15	91 101	100 111	24 26	36 40	14
T308 T309	16	113 126	124 138	28 30	45 50	16 18
T310	18	141	151	32	55	20
T311 T312	20	151 161	163 178	34 36	60 65	22 24
T313 T314 T315	24	171 181 193	190 202 216	38 40 40	65 80 80	26 28 28
T316	28	205	230	46	90	34
T317 T318	30	216 230	240 255	46 50	90 95	34 38
T319	32	242	270	50	95	38
T320 T321	32	262	290	52	100	40
T322	36	287	320	55	110	44
T324	42	322	355	60	120	50
T326 T328	47	352 382	385 415	65 70	130 140	55 60

9.3 Dowel Pins for Accurate Unit Mounting

The pillow type, square flange type, and oval flange type housings all have a dowel pin seat on the mounting base. If accurate positioning of the housing is required, then the bottom of the housing may be drilled for dowel pins which fit into corresponding holes in the mounting surface. The dimensions for the hole and pin sizes can be found in **Appendix table 5** in the back of the catalog.

10 Nomenclature

Nomenclature of FYH Ball Bearing Units conform to JIS B 1557, and comprise the bearing unit model code (comprising bearing model code and housing model code),

diameter series code, bore diameter. code, accessory code, and special code.

UC P 207 J L3

Bearing No.:	UC207L3
Housing No.:	P207J

UK P 209 J CD + H2309X

Bearing No.:	UK209+H2309X
Housing No.:	P209JE1
Steel plate cover No.:	(Open type) C-9x40 (Closed type) D-9

UC F 209 J L3 FD D1K2 G6 A1

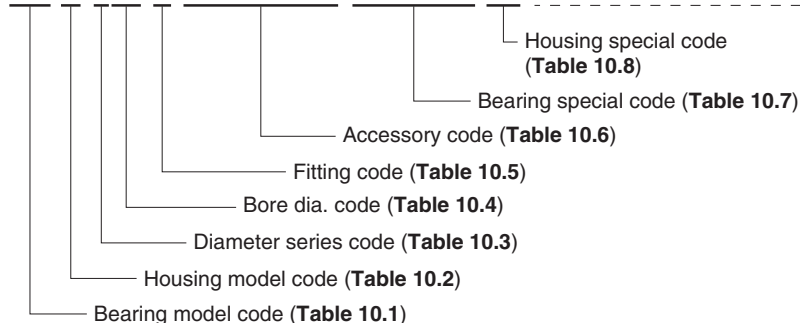

Bearing No.:	UC209L3D1K2G6
Housing No.:	F209JA1E3
Cast iron cover No.:	(Closed type) 209FD

Remark The above code shows an example of nomenclature structure. It may depend on the bearing unit model.

Table 10.1 Bearing model code

Bearing model code	Details
UC	with set screws
UC-S6	with set screws (stainless steel series)
UK	Tapered bore with adapter sleeve
NA	with eccentric locking collar
NC	with concentric locking collar
SB	with set screws (lightweight type)
SU	with set screws (clean series)
SA	with eccentric locking collar (lightweight type)
SA-F	with eccentric locking collar, Lubricating mechanism (lightweight type)
SU-S6	with set screws (stainless steel series)
ER	with set screws, cylindrical O.D., Lubricating mechanism, snap ring
ERC	with concentric locking collar, cylindrical O.D., Lubricating mechanism, snap ring
RB	with set screws, cylindrical O.D.
SBB	with set screws, cylindrical O.D.
SAA-F	with eccentric locking collar, cylindrical O.D. (lightweight type)

Table 10.2 Housing model code

Housing model code	Details
P	Pillow type
IP	Thick pillow type
PA	Tapped-Base pillow
PAN	Tapped-Base pillow
PH	High-Base pillow type
LP	Lightweight pillow type
P	Pillow type (clean series)
SP-H1	Pillow type (stainless steel series)
SPA-H1	Tapped-Base pillow (stainless steel series)

Table 10.2 Housing model code (continued)

Housing model code	Details
VP	Pillow type (thermoplastic series)
VPAN	Tapped-Base pillow (thermoplastic series)
SP	Pillow type (stainless steel series)
PP	Stamped steel pillow type
F	Square four-bolt flange type
NF	Square four-bolt flange type
FL	Oval two-bolt flange type
FA	Adjustable oval two-bolt flange type
FB	Three-bolt flange type
FC	Round flange cartridge type
FCF	Round flange cartridge type
FS	Square four-bolt cartridge flange type
FL	Oval two-bolt flange type (clean series)
TFD-H4	Three-bolt flange type (Ductile cast iron)
LF	Lightweight oval two-bolt flange type
SF-H1	Square four-bolt flange type (stainless steel series)
SFL-H1	Oval two-bolt flange type (stainless steel series)
SFL	Oval two-bolt flange type (stainless steel series)
SFC	Round flange cartridge type (stainless steel series)
PF	Stamped steel plate round three-bolt flange type
PFL	Stamped steel plate oval two-bolt flange type
VF	Square four-bolt flange type (thermoplastic series)
VFL	Oval two-bolt flange type (thermoplastic series)
VFB	Three-bolt flange type (thermoplastic series)
T	Take-up type
TRS	Narrow slot Take-up type
ST-H1	Take-up type (stainless steel series)
TH	Section steel frame take-up type
TL	Light channel steel frame take-up type
TU	Channel steel frame take-up type
PTH	Steel plate frame take-up type
NPTH	Steel plate frame take-up type

Table 10.2 Housing model code (continued)

Housing model code	Details
C	Cartridge type
HA	Hanger type

Table 10.3 Diameter series code

Diameter series code	Details
0	Small size light duty
2	Normal duty
X	Medium duty
3	Heavy duty

Table 10.4 Bore dia. code

Bore dia. code	Details
8	Nominal bearing bore dia. 8 mm
00	Nominal bearing bore dia. 10 mm
01	Nominal bearing bore dia. 12 mm
02	Nominal bearing bore dia. 15 mm
03	Nominal bearing bore dia. 17 mm
04	(Bore dia. code) × 5 = Nominal bearing bore dia. (mm)
01–8	– (bore dia. code) /16 = nominal bearing bore dia. (inch) (in this case, 8/16 = 1/2 inch = 12.7 mm) As for the bore dia. inch series bearing.

Table 10.5 Fitting code

Fitting code	Details
J	Tolerance class of spherical bore of the housing is J7 (not shown where the spherical bore diameter exceeds 120 mm)
H	Tolerance class of spherical bore of the housing is H7
K	Tolerance class of spherical bore of the housing is K7

Table 10.6 Accessory code

Accessory code	Details
C ¹⁾	Cover, open type
D ¹⁾	Cover, closed type
FC	Cast iron cover, open type
FD	Cast iron cover, closed type
L3	Triple-lip seal type

Note ¹⁾ Standard specifications of codes C and D are as shown below.

201–218, X05–X17.....Steel plate cover

X18–X20, 305–328.....Cast iron cover

Table 10.7 Bearing special code

Item	Bearing special code	Details
Grease	D1	U-RET EDM-1
	D2	SH33M
	D9	Demnum L-200
Set Screw	G4	Cone point
	G6	Capped full dog point
Seal	K2	Silicone rubber
	K3	Non-contact type
Sealing Device	P3	Without seal, slinger
	P4	Without seal
Others	S3	Air handling fit, 100% noise check, the anti-rotation pin
	S5	For blower (seal: K3, inner clearance and bearing accuracy are specially controlled)
	S6	Stainless steel bearing
	S7	Plated bearing (for corrosion-resistance)

Table 10.8 Housing special code

Item	Housing special code	Details
Grease Fitting Thread Bore dia.	A1	PT1/8 tube thread
	A2	PF1/8 tube thread
	A3	PT1/4 tube thread
	A4	PF1/4 tube thread
	A5	1/8NPT tube thread
Grease Fitting Thread Bore Position	B1	Right
	B2	Left
	B3	45°
	B5	30°
Machining	B7	Both right and left
	E1	Machined for stamped cover
	E3	Cast iron cover mounting groove (diameter series 2, X, 3)
Housing material	E4	Non-lubricating type
	H1	Stainless steel cast steel model (SCS13)
	H4	Ductile iron (FCD450-10)
	H5	Rolled steel for general purpose (SS400)
Grease Fitting	H9	Stainless steel cast steel model (SCS14)
	N1	B type (67.5°)
Surface treatment	N2	C type (90°)
	Z5	Nickel plated housing

11 Accuracy and Internal Clearance

Accuracy of a ball bearing unit is specified in JIS B 1558 (ball bearings for ball bearing units) and JIS B 1559 (housings for ball bearing units). FYH produces products conforming to these standards.

11.1 Accuracy of Bearings

Table 11.1 to Table 11.4 shows the accuracy of a ball bearings for ball bearing units.

Ball bearings for blowers (special code: S3, S5) are produced with greater accuracy than standard models (see Table 11.3).

Table 11.5 shows the tolerance limitations of inner rings for cylindrical bore bearings.

Table 11.2 Tolerances and tolerance values of outer rings of ball bearings inserts

Unit: μm

Nominal bearing outer dia. D (mm)		Variation of tolerance of average outer dia. ΔD_m		Radial runout of outer ring K_{ea}
Over	Incl.	Max.	Min.	Max.
18	30	0	-9	15
30	50	0	-11	20
50	80	0	-13	25
80	120	0	-15	35
120	150	0	-18	40
150	180	0	-25	45
180	250	0	-30	50
250	315	0	-35	60

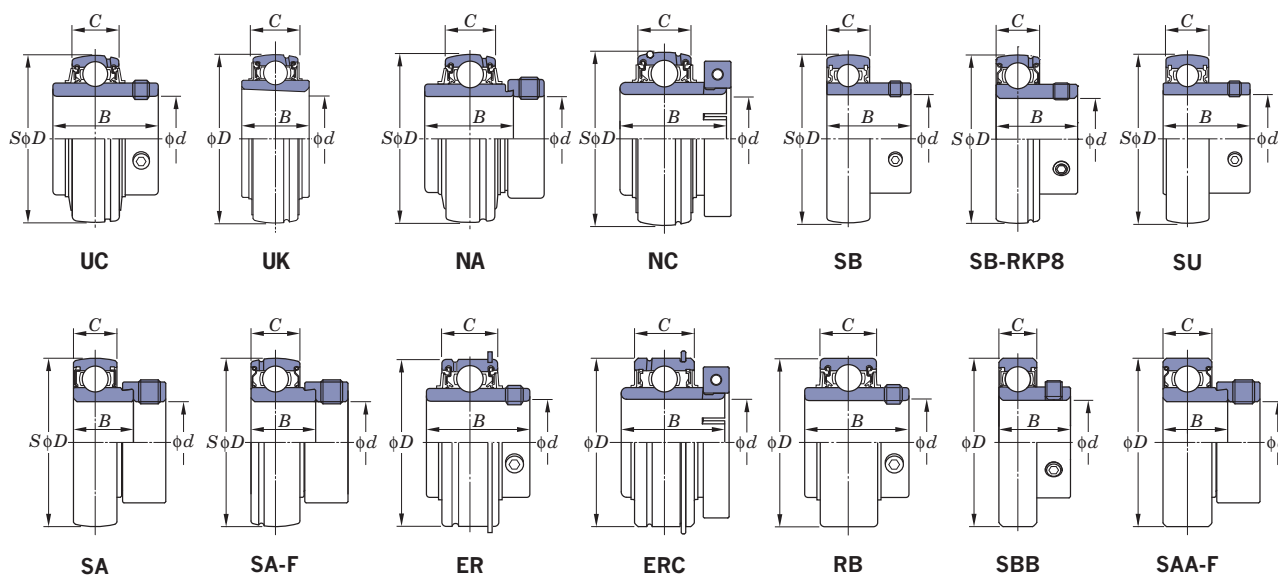
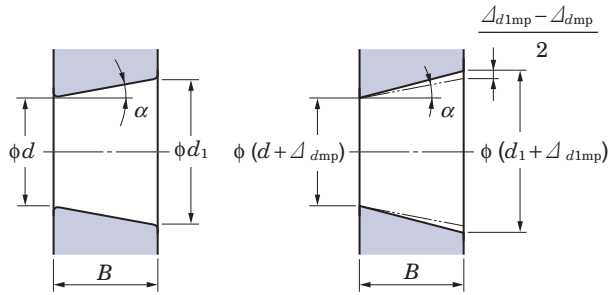

Table 11.1 Tolerances and tolerance values of inner rings of ball bearings for ball bearing units

Unit: μm

Nominal bearing bore dia. d (mm)		Variation of tolerance of average bore dia. in plane Δd_{mp}		Unequal bore dia. in plane V_{dsp}	Variation of tolerance of eccentricity on eccentric surface of inner ring and eccentric locking collar ΔH_s		Variation of tolerance of inner ring width ΔB_s		Radial runout of inner ring K_{ia}
Over	Incl.	Max.	Min.	Max.	Max.	Min.	Max.	Min.	Max.
-	10	+15	0	10	+100	-100	0	-120	10
10	18	+15	0	10	+100	-100	0	-120	15
18	31.75	+18	0	12	+100	-100	0	-120	18
31.75	50.8	+21	0	14	+100	-100	0	-120	20
50.8	80	+24	0	16	+100	-100	0	-150	25
80	120	+28	0	19	+100	-100	0	-200	30
120	180	+33	0	22	+100	-100	0	-250	35

Table 11.3 Variation of tolerances and tolerance values of tapered bore on bearing with tapered bore



Theoretical tapered bore

Tapered bore with variation of tolerance of average bore dia. in plane

Unit: μm

Nominal bearing bore dia. d , mm		Δd_{mp}		$\Delta d_{1mp} - \Delta d_{mp}$		$V_{dsp}^{1)}$
Over	Incl.	Max.	Min.	Max.	Min.	Max.
18	30	+33	0	+21	0	13
30	50	+39	0	+25	0	16
50	80	+46	0	+30	0	19
80	120	+54	0	+35	0	22
120	180	+63	0	+40	0	40

Note ¹⁾ To be applied to all the radial planes of tapered bore

Remarks 1. Applicable range

Applicable to tapered bore of inner ring of tapered bore radial bearing that standard value of taper ratio is 1/12.

2. Amount code

d_1 : Standard diameter at theoretical large end of tapered bore

$$\text{Standard diameter } d_1 = d + \frac{1}{12} B$$

Δd_{mp} : Variation of tolerance of average bore diameter in plane at theoretical small end of tapered bore

Δd_{1mp} : Variation of tolerance of average bore diameter in plane at theoretical large end of tapered bore

V_{dsp} : Unequal bore diameter in plane

B : Nominal inner ring width

α : 1/2 of nominal taper angle of tapered bore

$$\begin{aligned} \alpha &= 2^\circ 23' 9.4'' \\ &= 2.38594^\circ \\ &= 0.041643 \text{ rad} \end{aligned}$$

Table 11.4 Tolerances and tolerance values of inner rings of SC ball bearings

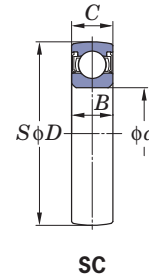

SC

Unit: μm

Nominal bearing bore dia. d (mm)		Variation of tolerance of average bore dia. in plane Δd_{mp}		Unequal average bore dia. in plane V_{dsp}	Radial runout of inner ring K_{ia}
Over	Incl.	Max.	Min.	Max.	Max.
10	18	0	-8	6	7
18	31.75	0	-10	6	8
31.75	50.8	0	-12	10	10

Table 11.5 Tolerance limitations for radius dimensions for the inner ring of cylindrical bore bearings

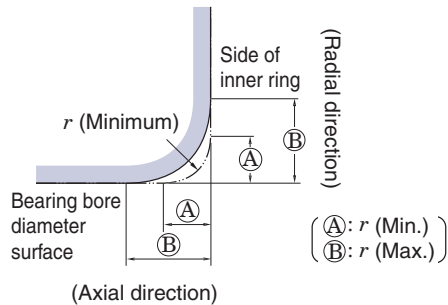

Unit: mm

r (Min.)	r (Max.)	
	Radial direction	Axial direction
0.6	1	2
1	1.5	3
1.1	2	3.5
1.5	2.3	4
2	3	4.5
2.1	4	6.5
2.5	3.8	6
3	5	8
4	6.5	9

Remark Though accurate profile of chamfered surface is not specified, the profile on the axial plane should not exceed the virtual arc of radius r (minimum) that contacts with the side of inner ring and the bearing bore diameter surface.

11.2 Accuracy of Housings

This section details the tolerance specifications of the inner diameter of the spherical bore of FYH housings. These values determine how tight or how loose the bearing fits inside the housing.

Table 11.6 shows the tolerance of the diameter of the spherical bore of housings.

Standard tolerance for mounted units, between the outer diameter of the bearing and the inner diameter of the housing, is a class J7 intermediate fit.

A class H7 tolerance allows greater clearance for applications where minor shaft alignment constantly occurs or in environments where higher temperatures can cause thermal expansion. An anti-rotation pin on the outer ring of the bearing is supplied with these units to prevent the outer ring of the bearing from spinning inside the housing.

A class K7 tolerance allows less clearance and is recommended to prevent the outer ring of the bearing from rotating inside the housing.

Fig. 11.1 shows examples of housing dimensions relative to installation position with tolerance values.

Table 11.6 Allowance of spherical bore diameter of housings

Unit: μm

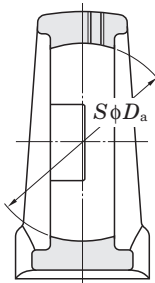

Nominal dia. of spherical bore D_a (mm)		Tolerance class H7		Tolerance class J7		Tolerance class K7	
		Variation of tolerance of spherical bore dia. ΔD_{dam}		Variation of tolerance of spherical bore dia. ΔD_{dam}		Variation of tolerance of spherical bore dia. ΔD_{dam}	
Over	Incl.	Max.	Min.	Max.	Min.	Max.	Min.
18	30	+21	0	+12	-9	+6	-15
30	50	+25	0	+14	-11	+7	-18
50	80	+30	0	+18	-12	+9	-21
80	120	+35	0	+22	-13	+10	-25
120	180	+40	0	+26	-14	+12	-28
180	250	+46	0	+30	-16	+13	-33
250	315	+52	0	+36	-16	+16	-36

Remark FYH selects J, H, or K depending on the applications.

Fig. 11.1 Dimensions relative to installation of housings with tolerances and tolerance values (representative example)

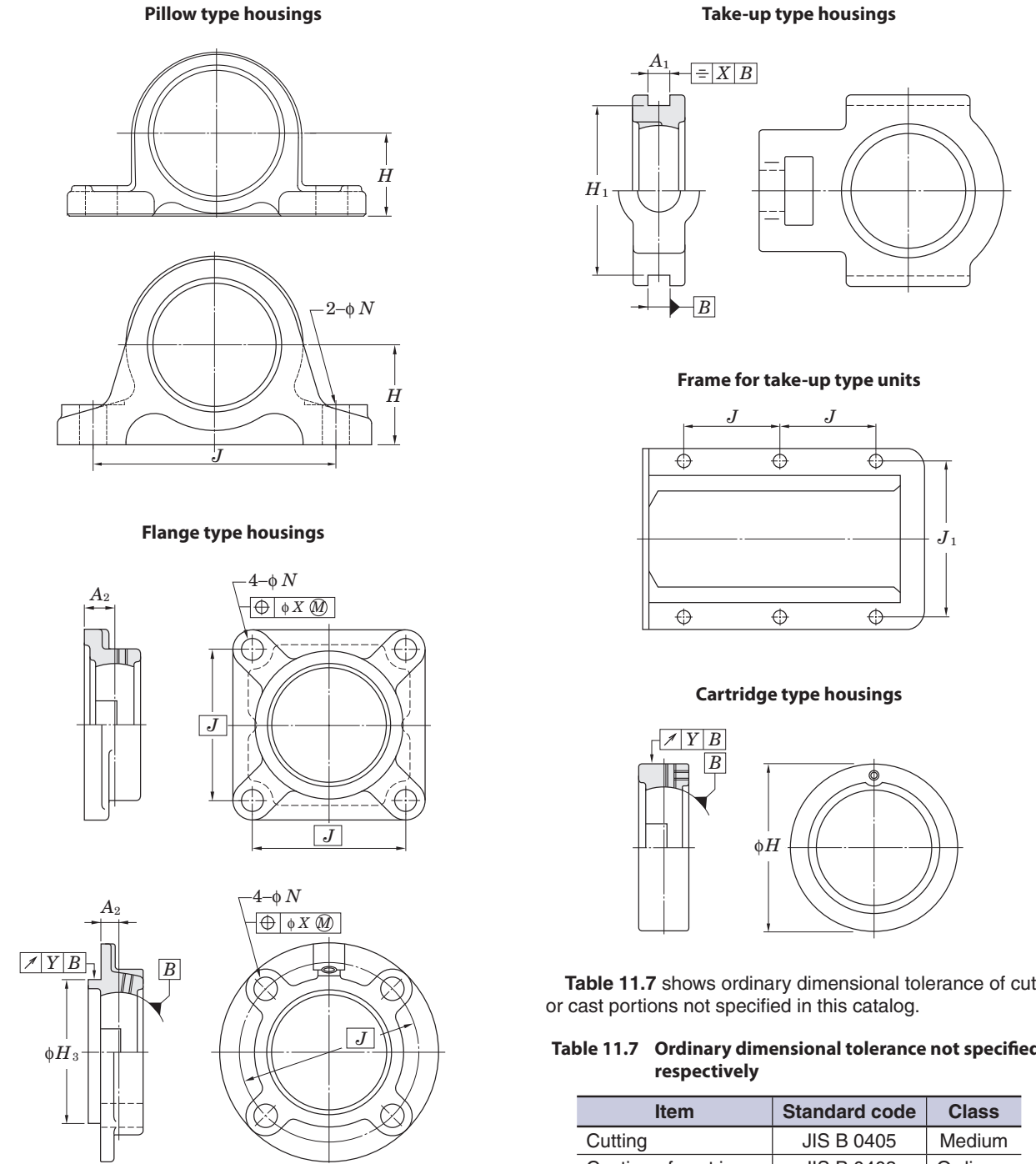

Remark Respective tolerances and tolerance values for housings are shown in dimensional tables.

Table 11.7 shows ordinary dimensional tolerance of cut or cast portions not specified in this catalog.

Table 11.7 Ordinary dimensional tolerance not specified respectively

Item	Standard code	Class
Cutting	JIS B 0405	Medium
Casting of cast iron	JIS B 0403	Ordinary
Casting of cast steel	JIS B 0403	Ordinary

11.3 Internal Bearing Clearance

Internal bearing clearance is defined as the allowable space between the bearing balls and the raceways. The degree of internal clearance, referred to as “operation clearance”, greatly influences operational life of the bearing as well as characteristics of heat, noise, and vibration.

If the clearance is exceptionally tight between the shaft and the inner ring of the bearing then expansion of the inner ring must be taken into consideration and the correct ball clearance should be selected. Transmission heat from the shaft is also a factor to consider when determining the correct amount of ball clearance (see “7 Operating temperature and bearing specifications”).

Table 11.8 shows the internal clearance applicable to specific operating conditions and Table 11.9 shows the available options for internal clearance.

Table 11.8 Internal clearance applicable to specific operating conditions

Type	Applicable internal clearance	
	Bearing with cylindrical bore	Bearing with tapered bore
Standard type	CN	C3
NC	CN	–
Stainless steel type	C3	–
Heat resistant type (suffix code: D1K2)	C4	C5
Heat resistant type (suffix code: D9K2)	C4	C5
Cold resistant type (suffix code: D2K2)	CN	C3
High speed type (suffix code: K3)	CN	C3
For blower (suffix code: S3)	CN	C3
For high speed blower (suffix code: S5)	C2	C3

Remark For bearings with suffix codes, as those indicated above, the clearance is implied and not indicated in the part number.

Table 11.9 Available options for internal clearance

Unit: μm

Nominal bearing bore dia. d (mm)		Internal clearance											
		C2		CN		GN		C3		C4		C5	
Over	Incl.	Min.	Max.	Min.	Max.	Min.	Max.	Min.	Max.	Min.	Max.	Min.	Max.
6	10	0	7	2	13	–	–	8	23	14	29	20	37
10	18	0	9	3	18	10	25	11	25	18	33	25	45
18	24	0	10	5	20	12	28	13	28	20	36	28	48
24	30	1	11	5	20	12	28	13	28	23	41	30	53
30	40	1	11	6	20	13	33	15	33	28	46	40	64
40	50	1	11	6	23	14	36	18	36	30	51	45	73
50	65	1	15	8	28	18	43	23	43	38	61	55	90
65	80	1	15	10	30	20	51	25	51	46	71	65	105
80	100	1	18	12	36	24	58	30	58	53	84	75	120
100	120	2	20	15	41	28	66	36	66	61	97	90	140
120	140	2	23	18	48	33	81	41	81	71	114	105	160

- Remarks 1. Radial internal clearance in this table conforms to JIS B 1558 (ball bearing inserts).
 2. Increase in radial internal clearance generated by measured load conforms to the table below. Smaller correction of C2 clearance is applicable to the minimum clearance, while larger correction is applicable to the maximum clearance.

Unit: μm

Nominal bearing bore dia. d (mm)		Measured load	Correction of clearance					
			N	C2	CN	GN, C3	C4	C5
2.5	18	24.5	3 – 4	4			4	
18	50	49	4 – 5	5			6	
50	280	147	6 – 8	8			9	

12 Materials

12.1 Bearing Material

Ball bearing inserts are comprised of inner and outer rings, balls, and steel ball cages all of which are made from the highest quality of bearing steel.

These bearings possess the following features.

- (1) High elastic limit to resist strong opposing force
- (2) High rolling fatigue strength to allow for heavy loads
- (3) Superior hardness
- (4) Superior wear resistance
- (5) Superior toughness against impact and shock loads
- (6) Superior precision of dimensional tolerances

High carbon chrome bearing steel is utilized for the bearing components as specified in JIS (Japanese Industrial Standards).

To increase reliability and reduce contamination within the material, a vacuum degassing process is executed to reduce non-metallic elements and any oxygen in the steel.

After the bearing is assembled it is heat tempered and quenched until the hardness reaches 60HRC.

Table 12.1 shows the chemical components of high carbon chrome bearing steel. Stainless steel bearing inserts (suffix: S6) utilize superior corrosion resistant JIS certified stainless steel.

Riveted steel ball cages are made of JIS certified cold rolled steel which is shown in **Table 12.2**.

12.2 Housing Material

FYH housings are made primarily of gray cast iron, and stamped steel. Gray cast iron is the most popular choice for mounted units because of its optimal characteristics of vibration absorption, high strength, and excellent heat dissipation.

Table 12.3 shows the mechanical properties of gray cast iron (FC200).

Nodular graphite cast iron, or ductile iron, (FCD450-10 of JIS G 5502) provides a good combination of rigidity and fracture resistance, and it is suitable where heavy vibration or impact forces are present.

Housings for units within the Clean Series are available in die-cast zinc alloy as well as stainless steel. Housing material for stamped steel units consists of thick gauge cold rolled sheet steel and steel strip.

Table 12.4 to **12.8** show the mechanical properties of these housing materials.

Table 12.1 Chemical components of high carbon chrome bearing steel (JIS G 4805)

Code	Chemical components (%)						
	C	Si	Mn	P	S	Cr	Mo
SUJ 2	0.95– 1.10	0.15– 0.35	0.50 or less	0.025 or less	0.025 or less	1.30– 1.60	–
SUJ 3	0.95– 1.10	0.40– 0.70	0.90– 1.15	0.025 or less	0.025 or less	0.90– 1.20	–

Table 12.2 Chemical components of cold rolled steel and steel strip (SPCC) (JIS G 3141)

Code	Chemical components (%)						
	C	Si	Mn	P	S	Ni	Cr
SPCC	0.15 or less	–	0.60 or less	0.100 or less	0.050 or less	–	–
SPCD	0.12 or less	–	0.50 or less	0.040 or less	0.040 or less	–	–

Table 12.3 Mechanical properties of gray cast iron (FC200)

Type code	Tensile strength N/mm ²	Hardness HB
FC200	200 or more	223 or less

Table 12.4 Mechanical properties of cast carbon steel products (JIS G 3101)

Type code	Yielding point or bearing force N/mm ²			Tensile strength N/mm ²	Thickness of steel mm	Tensile test piece	Elongation %	Bending property		
	Thickness of steel mm							Bending angle	Inside dia.	Test piece
	incl. 16	Over 16 incl. 40	Over 40							
SS400	245 or more	235 or more	215 or more	400– 510	Over 5, 16 max.	No.1A	17 or more	180°	1.5 times of thickness	No.1
					Over 16, 40 max.	No.1A	21 or more			
					Over 40	No.4	23 or more			

Table 12.5 Mechanical properties of zinc alloy die-cast (ZDC02) (JIS H 5301) (Reference)

Code	Tensile strength N/mm ²	Elongation %	Impact N · m/cm ²	Hardness HB
ZDC2	285	10	140	82

Table 12.6 Mechanical properties of stainless cast steel products (SCS 13, SCS 14) (JIS G 5121)

Type code	Bearing force N/mm ²	Tensile strength N/mm ²	Elongation %	Hardness HB
SCS 13	185 or more	440 or more	30 or more	183 or less
SCS 14	185 or more	440 or more	28 or more	183 or less

Correspondence standards

SCS 13: ISO GX5CrNi 19 9, ASTM CF-8 (AISI 304)

SCS 14: ISO GX5CrNiMo 19 11 2, ASTM CF-8M (AISI 316)

Table 12.7 Mechanical properties of cold rolled sheet steel and steel strip (SPCC) (JIS G 3141)

Type code	Tensile strength N/mm ²	Elongation %
SPCC	270 or more	34 or more
SPCD	270 or more	36 or more

Table 12.8 Mechanical properties of ductile cast iron (FCD450-10) (JIS G 5502)

Type code	Tensile strength N/mm ²	Elongation %
FCD	450 or more	10 or more

12.3 Materials of Parts and Accessories

Table 12.9 shows materials of parts and accessories of a ball bearing unit.

Table 12.9 Materials of parts and accessories of ball bearing units

Designations	Materials	Code	Standard code
Seal (standard type)	Nitrile rubber	NBR	–
Seal (heat resistant, cold resistant)	Silicone rubber	VMQ	–
Slinger (flinger)	Cold rolled steel plate and steel strip	SPCC	JIS G 3141
Stainless steel slinger (flinger)	Cold rolled stainless steel plate and steel strip	SUS304-CP, SUS304-CS	JIS G 4305
Steel plate cover	Cold rolled steel plate and steel strip	SPCD	JIS G 3141
Stainless steel plate cover	Cold rolled stainless steel plate and steel strip	SUS304-CP, SUS304-CS	JIS G 4305
Cast iron cover	Gray cast iron products	FC200	JIS G 5501
Hexagon socket set screw	Chrome molybdenum steel	SCM435	JIS G 4053
Stainless steel hexagon socket set screw	Stainless bar steel	SUS304	JIS G 4303
Adapter sleeve for bearing	Mechanical structural carbon steel	S17C	JIS G 4051
Lock nut for bearing	Mechanical structural carbon steel	S17C	JIS G 4051
Washer for bearing	Cold rolled steel plate and steel strip	SPCC	JIS G 3141
Locking collar	Mechanical structural carbon steel	S17C	JIS G 4051
Grease fitting	Copper and copper alloy rod	SUM24L	JIS G 4804

13 Performance

13.1 Bearing Friction Torque

Bearing friction torque is the conglomeration of the rolling friction between the balls with the inner and outer rings, the sliding friction between the balls and the cage, the agitating resistance of lubricants, and the friction resistance of the seals.

The specific amount of friction torque is influenced by the particular bearing model, dimensions, bearing load, rotating speed, and lubricating conditions.

Bearings with triple-lip seals and open cover seals will have greater friction torque and overall greater friction resistance.

Friction torque for bearings can be found by the formulas below.

$$M = M_p + M_k \quad (13.1)$$

$$M_p = \mu \cdot P \cdot \frac{d}{2} \quad (13.2)$$

Whereas,

M : Friction torque of bearing, $mN \cdot m$

M_p : Friction torque of sections changed by load, $mN \cdot m$

M_k : Friction torque of sections changed by rotating speed, $mN \cdot m$

μ : Friction coefficient (0.0015 to 0.002)

P : Load applied to bearings, N

d : Nominal bearing bore dia., mm

Note that the agitating resistance of lubricants and the friction resistance of the seals are difficult to calculate since the resistance fluctuates with speed.

Fig. 13.1 shows the result of measurement of friction torque of the typical ball bearing unit.

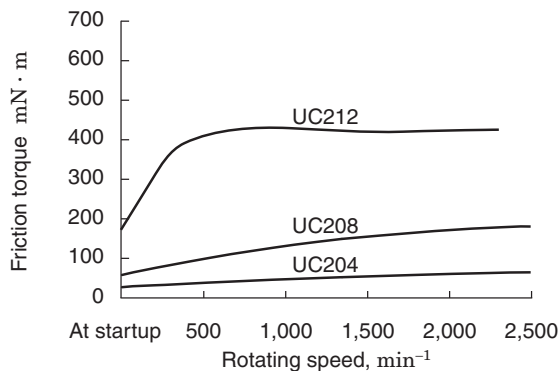

Fig. 13.1 Example of measurement result of ball bearing units

13.2 Bearing Temperature Increase

The increase in temperature of the bearing is represented as heat energy created from friction torque in the bearing during operation. The temperature of the bearing during operation increases in proportion to the amount of friction torque, and friction torque increases in proportion to the increase in bearing load.

The increase in temperature of the bearing depends on the heating value generated by friction in the bearing and the amount of heat discharged from the bearing and housing in which it is mounted. Therefore, the temperature level of the bearing is influenced by the environmental conditions of the location in which the bearing unit is installed (quality of heat radiation environment).

The operating temperature of the bearing unit increases gradually after startup of operation and reaches the maximum level after one or two hours if no abnormalities occur. Then it decreases slightly and enters a steady state (see Fig. 13.2).

If the operating conditions are not changed, bearing temperature will remain virtually constant, and measurement of the temperature and assumption of the bearing status are enabled.

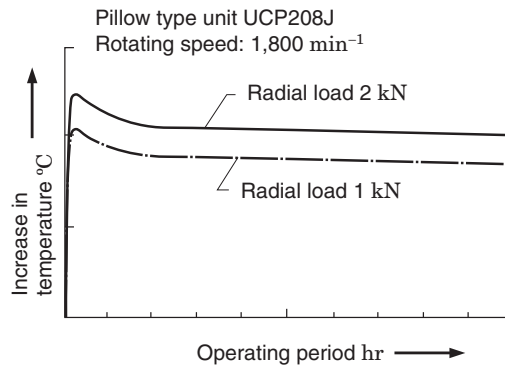

Fig. 13.2 Example of temperature measurement during operation of pillow type units

Increase in temperature during operation of the bearing depends on the type of seal used in the bearing as well as friction torque.

Increase in temperature of triple-lip bearings (suffix code: L3) is greater than that of the standard single lip model, and that of the non-contact seal (suffix code: K3, S5) is lower than the standard single lip model. Bearings for blowers and other high-speed applications are equipped with non-contact seals, with grease or oil, for high-speed operation as well as reduction of heat, vibration, and noise.

14 Handling

14.1 Installation

14.1.1 Installation of setscrew units

When installing setscrew units, it is important to tighten the setscrews to the shaft with the specified torque.

When the clearance between the inner ring and the shaft is small, then grind the surface of the shaft where the setscrew contacts and make a flat base (Fig. 14.1). It helps you to take the shaft out of the inner ring.

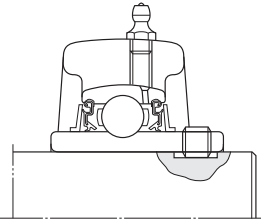

Fig. 14.1 Flat seat provided for shaft

If the unit is exposed to great load or excessive vibration, another option is to use a shouldered shaft and tighten the inner ring of the bearing with a shaft nut. (Fig. 14.2)

For dimensions of the shouldered shaft, see “9 Design of shaft and base”.

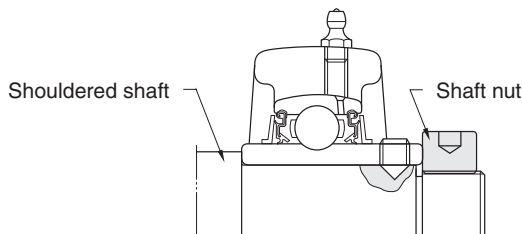







Fig. 14.2 Example of installation with a shouldered shaft and shaft nut

FYH Bearings are available with a variety of set screw options including **Double Point** and **Bullet Point** set screws which provide a secure fit to the shaft. Additional styles of setscrews are also available to meet a range of purposes and operating conditions (see Table 14.1).

Table 14.1 Set screws of ball bearings for units

Designations (code)	Details
Bullet Point  	The tip of the FYH Bullet Point setscrew has a ball shape, and it is designed to firmly grip the shaft by expanding its threads outward against the threads of the inner ring of the bearing as it is tightened. When shock or vibration are problems, the Bullet Point setscrew can remain affixed to the shaft longer than other set screw styles including double point, ball point, or others.
Double Point (G7) 	The cone point at the center of the screw, combined with the round point at the outer edge, provide excellent shaft contact and greatly reduced fitting error. This style is also available with a nylon film fused to the thread surface to prevent the screw from loosening during operation.
Cone Point (G4) 	The cone point setscrew has a 90° angle and fits a drilled cone seat in the shaft. It allows correct positioning on the shaft and prevents shaft movement in an axial direction. (Fig.14.3)
Capped Full Dog Point (G6) 	The capped full dog point setscrew fits into the keyed groove in the shaft and allows for expansion and contraction of the shaft. It tightens to the inner ring of the bearing (not the shaft) to allow the shaft to float within the bore of the bearing.

When correct positioning is required, make a drilled cone base on the shaft, and tighten the shaft, using a cone point set screw (Fig. 14.3).

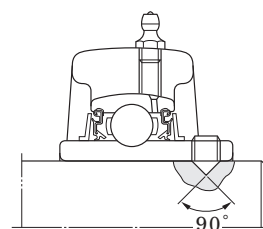

Fig. 14.3 Drilled seat provided for shaft

Contact FYH for additional set screw styles.

Shown below are installation procedures for bearing units with setscrews.

- (1) Inspect the unit to ensure that the rigidity of the base, flatness of the mounting surface, and tolerance of the shaft meet the required standards. Check the shaft for bends, burrs, and other flaws.
- (2) Make sure that the set screws are retracted far enough so that they do not contact the shaft as the bearing is installed.
- (3) Fit the bearing unit onto the shaft and slide it to the specified position. In order to secure a tight fit, press-fit the bearing unit to the shaft with a press, cold-fit by cooling the shaft, or shrink-fit the bearing unit by warming it with an air bath (100 °C or less). Avoid striking the bearing with a hammer to press-fit the bearing to the shaft. If you give a strong impact to the side surface of the inner ring, the both slinger moves, and it may cause a problem.
- (4) Align the bearing unit to the specified position on the base and affix it with washers and bolts. (Fig. 14.4). Use a torque wrench to tighten the bolts to the housing to the specified torque setting. For mounting bolt torque specifications, see **Appendix table 2** in the back of the catalog.



Fig. 14.4 Installation of setscrew units

- (5) Tighten both of the setscrews on the inner ring to the specified torque setting (Fig. 14.5). For setscrew torque specifications, see **Appendix table 3** in the back of the catalog.



Fig. 14.5 Tightening of set screws

- (6) Turn the shaft by hand and tighten the setscrews of all other bearings on the same shaft to the specified torque setting.

- (7) Finally, turn the shaft by hand and make sure that it rotates without any problems.

14.1.2 Installation of adapter style units

Adapter units, comprised of an adapter sleeve, locknut, and washer, can be installed into environments where they are exposed to excessive vibration and impact.

It is of great importance that these units are properly mounted. If the locknut is not properly tightened, the sleeve may be loose which could lead to slippage and wear on the shaft or bearing. Conversely, if the locknut is over-tightened, the inner ring of the bearing can expand and reduce internal ball clearance which could cause excessive heat and premature failure.

Installation procedures for adapter style bearings are shown below.

- (1) Inspect the unit to ensure that the rigidity of the base, flatness of the mounting surface, and tolerance of the shaft meet the required standards. Check the shaft for bends, burrs, and other flaws.
- (2) Slide the adapter sleeve onto the shaft where the bearing unit will be installed.
If the sleeve is too tight, place a screwdriver in the slotted portion of the sleeve and expand the slot to open the sleeve.
- (3) Slide the bearing unit over the shaft and onto the adapter sleeve, then place a cylindrical reinforcing ring against the inner ring of the front side of the bearing. Seat the adapter sleeve by lightly tapping all around the backside of the sleeve (Fig. 14.6).

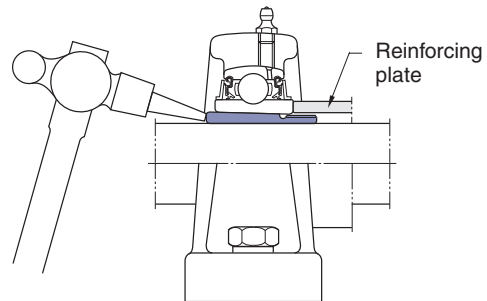

Fig. 14.6 Fitting adapter sleeve to bearing with tapered bore

- (4) Attach the lock washer so that the tab fits into the slot in the sleeve, and, making sure the tapered side is facing the bearing, tighten the locknut on the sleeve by hand.
- (5) Align the bearing unit to the specified position on the base and affix it with washers, and bolts. Use a torque wrench to tighten the bolts to the housing to the specified torque setting. For mounting bolt torque specifications, see **Appendix table 2** in the back of the catalog.
- (6) Use a torque wrench to tighten the locknut to the correct specification (Fig. 14.7). For locknut torque specifications, see **Appendix table 4** in the back of the catalog.



Fig. 14.7 Tightening locknut

- (7A) For pillow block housings, loosen the mounting bolts and adjust the unit axially while rotating the shaft by hand. Then re-tighten the mounting bolts to the correct specification.
- (7B) For flange block housings, the position of the unit must be in the correct axial position in relation to the shaft, so take extra care to properly align them before completing installation.
- (8) Bend one of the tabs on the washer so that it fits into one of the slots on the locknut (**Fig. 14.8**).



Fig. 14.8 Bending claw of washer
(Locking locknut)

- (9) Finally, turn the shaft by hand and make sure that it rotates without any problems.

14.1.3 Installation of units with eccentric locking collars

Eccentric locking collar bearings provide another option for shaft locking. Since the rotating force of the shaft increases the tightening force of the eccentric ring to the shaft, this style of bearing allows a secure grip to the shaft.

Since the rotating force of the shaft increases the tightening force of the eccentric ring to the shaft, the unit with eccentric locking collar allows secure fixing of the bearing (**Fig. 14.9**).



Fig. 14.9 Ball bearing units with eccentric locking collar

Installation procedures for eccentric locking collar style bearings are shown below.

- (1) Inspect the unit to ensure that the rigidity of the base, flatness of the mounting surface, and tolerance of the shaft meet the required standards. Check the shaft for bends, burrs, and other flaws.
- (2) Slide the bearing unit onto the shaft, and place it at the specified mounting position.
- (3) Align the bearing unit to the specified position on the base and affix it with washers, and bolts. (**Fig. 14.4**). Use a torque wrench to tighten the bolts to the housing to the specified torque setting. For mounting bolt torque specifications, see **Appendix table 2** in the back of this catalog.
- (4A) Fit the eccentric section of the inner ring of the bearing to the eccentric recessed section of the eccentric locking collar, and rotate the collar in the direction of shaft rotation. Then, tighten the setscrew on the eccentric locking collar to the specified torque setting (**Fig. 14.10**).



Fig. 14.10 Installing eccentric locking collar

(4B) The NU-LOC collar is tightened by a hexagon head bolt to a specified torque setting in order to apply the correct amount of force to the inner ring of the bearing. (Fig. 14.11)

Regarding tightening torque for set screws or hexagon head bolts, see **Appendix Table 3** in the back of this catalog.



Fig 14.11 Installation of NU-LOC units

- (5) Rotate the shaft by hand and then install the next eccentric locking collar unit to the shaft.
- (6) Finally, turn the shaft by hand and make sure that it rotates without any problems.

14.1.4 Installing units with covers

Covers for ball bearing units are available in two types, steel plate and cast iron. Install both the covers at last after installation of the bearing and housing is complete.

Procedures for installation of the ball bearing units with covers are shown below.

- (1) Apply grease all around the seal lip of the cover, and pack the internal space of the cover with grease (approximately 1/3 to 1/2 of the space capacity) (Fig. 14.12).

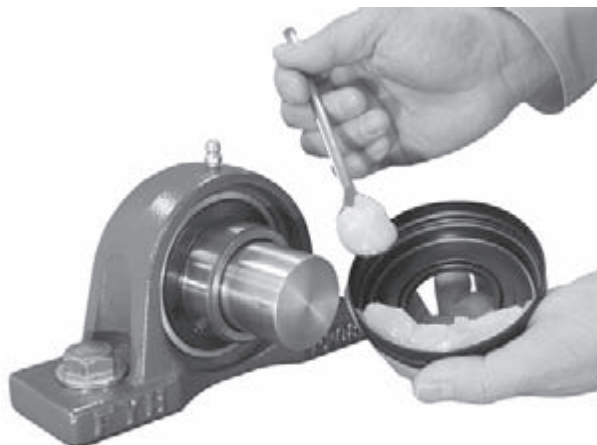
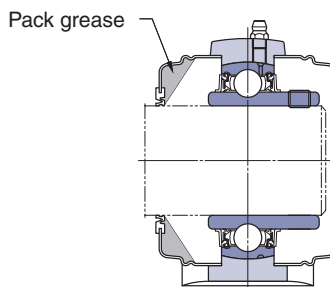

Fig. 14.12 Packing grease in internal space of seal lip of covers

- (2) Make sure that the bearing unit is securely fixed to the shaft and mounting base.
- (3) Slide the cover over the shaft to the groove in the housing and lightly press it into place.
- (4A) For stamped steel covers, use a plastic mallet to prevent deformation, and evenly tap all around the periphery of the cover to install it to the housing (Fig. 14.13).

To remove the stamped steel cover, put a screwdriver into the groove on the periphery of the cover and slightly pry it.



Fig. 14.13 Installing steel plate covers

(4B) When installing a cast iron cover, fit the cover to the cover groove of the housing, and affix it with the supplied bolts.

For the tightening torque of the cast iron cover mounting bolts, see the **Appendix table 2** at the end of this catalog.

- (5) Install another cover to the housing in a similar manner.
- (6) Check for abnormality of the installed cover.
- (7) Finally, turn the shaft by hand, and check for abnormality in the bearing.

14.2 Test Run Inspection

After installation of the ball bearing unit is complete, execute the test run inspection to ensure that it was done properly.

The test run inspection should be executed by following the procedures below.

- (1) Turn the shaft by hand and make sure that the bearing rotates smoothly.

If there is any resistance, vibration, excessive rotational torque, or uneven rotation, the bearing is judged to be faulty.

- (2) Execute a powered run with no load and at low speed, and check for abnormal noise and vibration.
- (3) Execute a powered run under normal operating conditions and check for abnormal noise, vibration, and temperature increase.

Table 14.2 shows the main faults that may occur during the test run inspection of the ball bearing unit and causes.

Table 14.2 Main causes of bearing failure during test runs and their causes

Faults	Causes
Excessive torque, uneven rotating torque	<ul style="list-style-type: none"> (1) Faulty installation, causes preload on bearing (2) Inappropriate handling or installation, leading to interference of seal with slinger (3) Excessive tightening of locknut (adapter) causing too small internal clearance of bearing
Abnormal noise, abnormal vibration	<ul style="list-style-type: none"> (1) Improper tightening of set screws or of mounting bolts (2) Excessively large internal clearance of bearings (3) Bent shaft, or shouldered shaft may be machined eccentrically (4) Shaft tolerance chosen improperly (5) Mounting base not rigid or flat
Abnormal temperature increase	<ul style="list-style-type: none"> (1) Too small internal clearance of bearing (2) Faulty installation, causes preload on bearing (3) Load too great (4) Allowable rotational speed exceeded (5) Mounting base not rigid or flat (6) Inappropriate handling or installation, leading to interference of seal with slinger

14.3 Periodic Inspection

FYH Ball Bearing Units do not need to be inspected as frequently as lower quality bearings. However, it is good practice to set up an inspection schedule for even these high quality bearings.

Since a ball bearing unit cannot be disassembled for inspection of the internal status of components, the external appearance of the bearing must be inspected to give tell-tale signs of the status and expected life of the bearing. The following characteristics must be checked per the inspection schedule that is established for a particular application.

- (1) Overall appearance
- (2) Loose set screws or mounting bolts
- (3) Noise from vibration
- (4) Temperature of the bearing housing or the inner ring
- (5) Grease supply interval and quantity of grease injected into the bearing (either too much or too little grease can be detrimental to the life of the bearing)

Table 14.3 shows the main faults that are usually found during periodic inspections and their causes.

If any fault is found in a ball bearing unit during an inspection, then immediate action must be taken to correct the situation and prevent deterioration of the bearing components. If serious damage has already occurred to the bearing unit, then the bearing unit must be replaced immediately to prevent damage to other machine components.

Table 14.3 Main faults found during periodic inspection and their causes

Faults	Causes
Excessive torque	<ul style="list-style-type: none"> (1) Degraded grease (2) Interference of seal with slinger due to excessive supply of grease (3) Deformation of slinger causing interference with seal (4) High load due to shaft expansion
Abnormal noise, abnormal vibration	<ul style="list-style-type: none"> (1) Improper tightening of set screws locknut (adapter) or of mounting bolts (2) Wear on inner ring of bearing or shaft due to creep or fretting (3) Ingress of foreign matter (dirt) into bearing (4) Damage to cage or ball surfaces due to rolling fatigue (5) Indentation on raceway surface or ball surface due to excessive load (6) Warped or bent shaft
Abnormal temperature increase	<ul style="list-style-type: none"> (1) Degraded grease (2) Interference of seal with slinger due to excessive supply of grease (3) Deformation of slinger causing interference with seal (4) Looseness of setscrew, eccentric locking collar or adapter lock nut for tapered bore bearings (5) Load due to shaft expansion (6) Damage to cage or ball surfaces due to rolling fatigue

14.4 Supply of Grease

FYH Ball Bearing units are supplied with high quality FYH Lithium Bearing grease and seals. Therefore, under clean operating conditions, light loads, low speeds, and low temperatures the bearing may be used with no further lubrication.

However, under harsher operating conditions and environments, the grease will deteriorate much more rapidly.

This would include environments exposed to dust, moisture, or higher operating temperatures.

In such cases, a re-greasing schedule must be established to prevent premature failure of the bearing. The life of the bearing can be greatly extended by proper attention to the re-greasing schedule and by supplying the proper amount of grease. Please note that too much grease can be detrimental as well as too little grease.

14.4.1 Grease life and supply intervals

The grease life of a bearing unit can be found using **Formula (4.7)** in page 27.

The re-greasing schedule should be set at 1/4 to 1/3 of the grease life found by the calculation shown above; however this may be adjusted for particularly demanding environments or conditions.

In addition, some environments may be unusually dirty or wet, and these conditions may be exacerbated by higher temperatures. Under such harsh conditions, a more frequent re-greasing schedule will extend the life of the bearing.

Under normal operating conditions, adhere to the guidelines outlined in **Table 2.2** in page 10.

14.4.2 Amount of grease

The amount of grease initially supplied in a new FYH Ball Bearing Unit is approximately 30 to 35% of the internal space capacity of the bearing. If the bearing is over greased, the agitation of the grease causes internal friction and heating of the bearing. The first sign of failure will be excessive grease finding its way to the outside of the bearing. DO NOT exceed the initial greasing amount.

Table 14.4 shows the recommended amount of grease to be used for re-greasing FYH bearings.

In a severely dusty or wet environments, the amount of grease may be as much as doubled if operating speeds are low.

Note:

1. **Table 14.4** applies to UK units as well.
2. For greasing triple-lip (L3) type bearings, use 1 1/2 times the amount of grease recommended in the table.
3. Values shown in the table are applicable to standard grease (density: 0.9 g/ml). If a compatible grease of another specific gravity is used, then the proper conversion must be made to insure that the recommended volume is put into the bearing.

Table 14.4 Amount of recommended grease for ball bearing units

Bore dia. code	Greasing amount, g		
	Diameter Series ¹⁾		
	UC200	UCX00	UC300
01	0.7		
02	0.7		
03	0.7		
04	0.7		
05	0.8	1.3	1.8
06	1.3	1.8	2.5
07	1.8	2.3	3.4
08	2.3	2.8	4.6
09	2.8	3.2	6.3
10	3.2	4.3	8.1
11	4.3	5.5	11
12	5.5	6.8	14
13	6.8	7.7	17
14	7.7	9	21
15	9	11	25
16	11	14	29
17	14	17	34
18	17	21	40
19	–	–	47
20	–	29	61
21	–	–	69
22	–	–	84
24	–	–	98
26	–	–	126
28	–	–	151

The basic bearing size number consists of the duty code (2, X, or 3) followed by the inner ring size code (07, 10, 24, etc.)

14.4.3 Types of grease supplied

Many different types of grease are available for use in ball bearings. However, if a non-compatible grease is used, particularly a non-lithium based grease, then performance may be drastically reduced.

Only use the grease recommended in **Table 2.1** (page 10) to assure optimum performance of your bearings.

If another grease is used in an emergency situation, for instance, please assure that this grease is compatible, with a lithium base, at the minimum.

14.4.4 Relubricating the unit at the specified interval

Note **Fig. 14.14** which shows the grease fitting, grease groove and grease holes for relubrication of the unit.

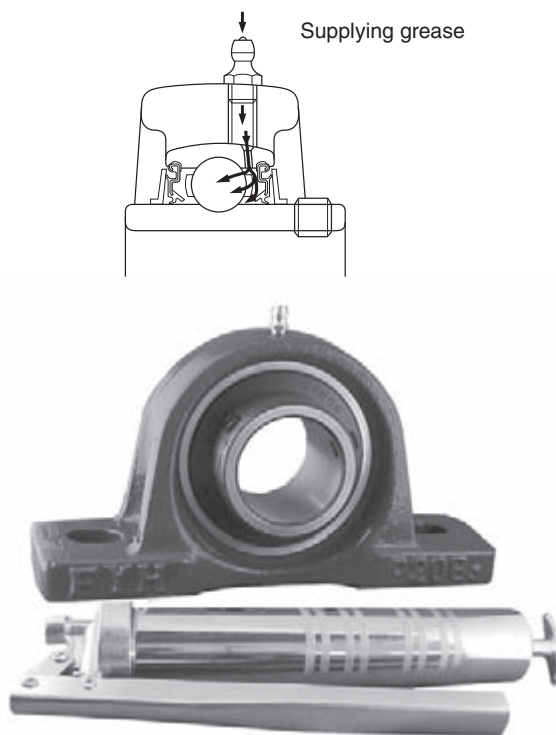

Fig. 14.14 Supplying grease to ball bearing units

- (1) Clean the grease fitting and the area around it to prevent dirt and foreign material from entering the unit.
- (2) Clean the grease gun and pack clean grease.
- (3) Grease the unit with the recommended amount of grease.

When lubricating the ball bearing unit, slowly turn the shaft with your hand. This allows the fresh grease to be uniformly distributed inside the unit.

If it is difficult to access the standard straight type grease fitting with a grease gun, 67.5° and 90° angled fittings are available as an option. See the images below of these grease fittings. Contact FYH for more information.

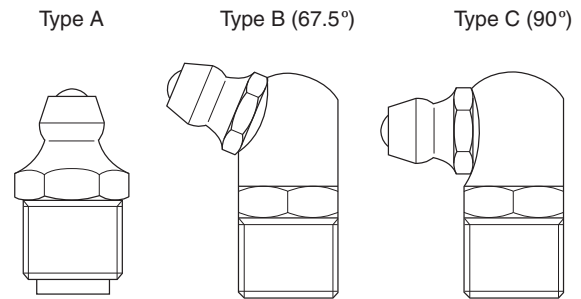

Fig. 14.15 Types of grease fittings for ball bearing units

When using a centralized automatic lubrication system, with ball bearings, it is important to use softer grease than normal. The grease should be specified with a “worked penetration number” between 300 and 380. This is NLGI grade “0” or “1”. Piping from the lubricating system must be sized so that the specified volume of grease is supplied.

Piping must be connected to the threaded hole on the ball bearing unit. This is either 1/4-28 tapered threads for units up to and including 210 ring size, or 1/8 PT (BSPT) for ball bearing units with a 211 ring size and larger. If the piping size used is larger than the threaded hole in the ball bearing unit, then the appropriate reducing coupling (or street elbow) must be used to fit the threaded hole.

Fig. 14.16 shows the body of a pipe reducer.

When using an automatic centralized lubrication system, it is imperative to assure that the correct volume of grease is supplied to each individual bearing as specified in **Table 14.4**. The total amount of grease is a multiple of the number of bearings being supplied by the central lubrication system.

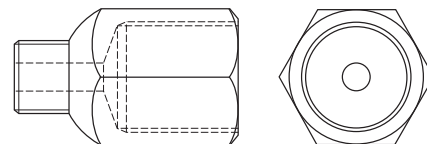

Fig. 14.16 Reducing coupling for centralized lubrication systems

14.5 Replacing Bearings

If a bearing insert needs to be replaced, it is not always necessary to replace the housing if the housing is intact.

After carefully inspecting the housing to ensure that it is not damaged, simply insert a new bearing into the old housing.

Replacement procedures for a bearing insert are listed below.

- (1) Remove the complete bearing unit from the shaft and mounting base.
- (2) Screw in the set screws so that the head of each set screw does not protrude outside the outer diameter of the inner ring. Otherwise, the head of the set screw may damage the bearing seat inside the housing.
- (3) Use a bar or pipe to rotate the bearing 90° until the bearing is horizontal.
- (4) Remove the bearing insert from the housing via the loading slot in the back of the housing.

Reverse the above procedure to put in a new bearing insert. Ensure that the set screws are screwed in before proceeding with the replacement.



15 Dimensional Tables for Ball Bearing Units

1 Pillow Block Units

Pillow Block Units

UCP (*d* 12 ~ 140) 82
 NAP (*d* 12 ~ 75) 88
 NAP-E (*d* 1 3/16 ~ 2 15/16) 90
 NAPK (*d* 12 ~ 75) 92
 NCP (*d* 20 ~ 60) 94
 UKP (*d*₁ 20 ~ 125) 96

Thick Pillow Block Units

UCIP (*d* 40 ~ 140) 102
 UKIP (*d*₁ 35 ~ 125) 104

Tapped-Base Pillow Block Units

UCPA (*d* 12 ~ 50) 106
 UCPAN (*d* 20 ~ 35) 108
 NCPA (*d* 20 ~ 50) 110
 NCPAN (*d* 20 ~ 35) 112

High-Base Pillow Block Units

UCPH (*d* 12 ~ 50) 114

Narrow Inner Ring Bearing Pillow Block Units

SBP-RKP8 (*d* 20 ~ 40) 116
 SAP-FP9 (*d* 20 ~ 55) 116
 SBPAN-RKP8 (*d* 20 ~ 35) 118
 SAPAN-FP9 (*d* 20 ~ 35) 118

Light Pillow Block Units

BLP (*d* 12 ~ 40) 120
 ALP (*d* 12 ~ 40) 120

Compact Pillow Block Units

UP (*d* 10 ~ 30) 122

Corrosion Resistant Series Pillow Block Units

UCSP-H1S6 (*d* 12 ~ 60) 124
 UCSPA-H1S6 (*d* 12 ~ 40) 126
 USP-S6 (*d* 10 ~ 30) 128
 UCVP-S6 (*d* 20 ~ 50) 130
 UCVP-ES7 (*d* 20 ~ 50) 132
 UCVPAN-ES7 (*d* 20 ~ 35) 134

Stamped Steel Pillow Block Units

SBPP (*d* 12 ~ 30) 136
 SAPP (*d* 12 ~ 30) 136

2 4-Bolt Flange Units

4-Bolt Flange Units

UCF (*d* 12 ~ 140) 138
 UCF-E (*d* 12 ~ 85) 144
 NANF (*d* 12 ~ 60) 148
 NCF (*d* 20 ~ 60) 150
 NCF-E (*d* 20 ~ 60) 152
 UKF (*d*₁ 20 ~ 125) 154

Square Piloted 4-Bolt Flange Units

UCFS (*d* 25 ~ 140) 160
 UKFS (*d*₁ 20 ~ 125) 162

Narrow Inner Ring Bearing 4-Bolt Flange Units

SBF-RKP8 (*d* 20 ~ 40) 164
 SAF-FP9 (*d* 20 ~ 55) 164

Corrosion Resistant Series 4-Bolt Flange Units

UCSF-H1S6 (*d* 20 ~ 60) 166
 UCSF-EH1S6 (*d* 20 ~ 60) 168
 UCVF-S6 (*d* 20 ~ 40) 170
 UCVF-ES7 (*d* 20 ~ 40) 172

3 Oval Flange Units

2-Bolt Flange Units

UCFL (*d* 12 ~ 120) 174
 UCFL-E (*d* 12 ~ 85) 180
 NANFL (*d* 12 ~ 55) 184
 NCFL (*d* 20 ~ 60) 186
 NCFL-E (*d* 20 ~ 60) 188
 UKFL (*d*₁ 20 ~ 110) 190

Adjustable 2-Bolt Flange Units

UCFA (*d* 12 ~ 55) 194

3-Bolt Flange Units

UCFB (*d* 12 ~ 50) 196

Narrow Inner Ring Bearing 2-Bolt Flange Units

SBFL-RKP8 (*d* 20 ~ 40) 198
 SAFL-FP9 (*d* 20 ~ 55) 198

Light 3-Bolt Flange Units

SBTFD-H4RKP8 (*d* 12 ~ 35) 200
 SATFD-FH4P9 (*d* 12 ~ 35) 200

Light 2-Bolt Flange Units

BLF (*d* 12 ~ 35) 202
 ALF (*d* 12 ~ 35) 202

Compact 2-Bolt Flange Units

UFL (*d* 8 ~ 30) 204

Corrosion Resistant Series 2-Bolt Flange Units

UCSFL-H1S6 (*d* 12 ~ 50) 206
 UCSFL-EH1S6 (*d* 12 ~ 50) 208
 USFL-S6 (*d* 10 ~ 30) 210
 UCVFL-S6 (*d* 20 ~ 40) 212
 UCVFL-ES7 (*d* 20 ~ 40) 214

Corrosion Resistant Series 3-Bolt Flange Units

UCVFB-ES7 (*d* 20 ~ 35) 216

4 4-Bolt Flange Cartridge Units

4-Bolt Flange Cartridge Units

UCFC (<i>d</i> 12 ~ 100)	218
UCFCX-E (<i>d</i> 25 ~ 100)	222
UCFCF (<i>d</i> 25 ~ 55)	224
NCFC (<i>d</i> 20 ~ 60)	226
UKFC (<i>d</i> ₁ 20 ~ 90)	228

Narrow Inner Ring Bearing

4-Bolt Flange Cartridge Units

SBFC-RKP8 (<i>d</i> 20 ~ 40)	232
SAFC-FP9 (<i>d</i> 20 ~ 55)	232

Corrosion Resistant Series

4-Bolt Flange Cartridge Units

UCSFC-H1S6 (<i>d</i> 20 ~ 40)	234
--------------------------------------	-----

5 Stamped Steel Flange Units

Stamped Steel 3-Bolt Flange Cartridge Units

SBPF (<i>d</i> 12 ~ 35)	236
SAPF (<i>d</i> 12 ~ 35)	236

Stamped Steel 2-Bolt Flange Units

SBPFL (<i>d</i> 12 ~ 35)	238
SAPFL (<i>d</i> 12 ~ 35)	238

6 Take-Up Units

Take-Up Units

UCT (<i>d</i> 12 ~ 140)	240
UCT-E (<i>d</i> 12 ~ 85)	246
NAT-E (<i>d</i> 12 ~ 75)	250
NCT (<i>d</i> 20 ~ 60)	252
NCT-E (<i>d</i> 20 ~ 60)	254
UKT (<i>d</i> ₁ 20 ~ 125)	256

Narrow Slot Take-Up Units

UCTRS (<i>d</i> 25 ~ 35)	260
---------------------------------	-----

Corrosion Resistant Series Take-Up Units

UCST-H1S6 (<i>d</i> 20 ~ 50)	262
UCST-EH1S6 (<i>d</i> 20 ~ 50)	264

Section Steel Frame Take-Up Units

UCTH (<i>d</i> 12 ~ 65)	266
--------------------------------	-----

Channel Steel Frame Take-Up Units

UCTL (<i>d</i> 20 ~ 45)	268
UCTU (<i>d</i> 40 ~ 90)	270

Steel Plate Frame Take-Up Units

SBPTH (<i>d</i> 12 ~ 25)	274
SBNPTH (<i>d</i> 12 ~ 25)	276

7 Other Units

Cartridge Units

UCC (<i>d</i> 12 ~ 140)	278
UKC (<i>d</i> 20 ~ 125)	282

Hanger Units

UCHA (<i>d</i> 12 ~ 75)	284
--------------------------------	-----

8 Ball Bearing Inserts

Cylindrical bore (with set screws)

UC, SB, SB-RKP8, SU (<i>d</i> 8 ~ 140)	286
---	-----

Stainless steel series Cylindrical bore (with set screws)

UC-S6, SU-S6 (<i>d</i> 10 ~ 60)	294
--	-----

Cylindrical bore (with eccentric locking collar)

SA, SA-F, NA (<i>d</i> 12 ~ 75)	296
--	-----

Cylindrical bore (with concentric locking collar)

NC2 (<i>d</i> 20 ~ 60)	302
-------------------------------	-----

Cylindrical bore (with concentric locking collar)

Cylindrical O. D.

ERC (<i>d</i> 20 ~ 60)	304
-------------------------------	-----

Tapered bore (with adapter)

UK (<i>d</i> ₁ 20 ~ 125)	306
--	-----

Cylindrical bore (with set screws)

Cylindrical O. D.

ER, RB (<i>d</i> 12 ~ 60)	312
----------------------------------	-----

Cylindrical bore (with set screws)

Cylindrical O. D.

SBB-RK (<i>d</i> 12 ~ 55)	314
----------------------------------	-----

Cylindrical bore (with eccentric locking collar)

Cylindrical O. D.

SAA-FP7 (<i>d</i> 12 ~ 55)	314
-----------------------------------	-----

Cylindrical bore

SC (<i>d</i> 17 ~ 40)	316
------------------------------	-----

9 Bearing Adapter

H2300X (<i>d</i> ₁ 20 ~ 125)	318
--	-----

NAP
Cylindrical bore
(with eccentric locking collar)
 d 12 ~ 75 mm

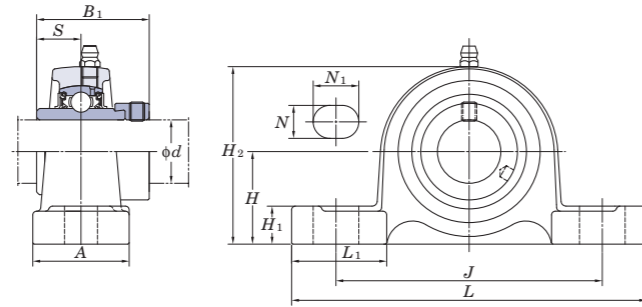

Variations of tolerance of distance from mounting bottom to center of spherical bore (ΔH_2)

Housing No.	Unit: mm ΔH_2
P203~P210	±0.15
P211~P215	±0.2

Shaft Dia. mm inch d	Dimensions inch mm											Bolt Size inch mm	Unit No.	Housing No.	Bearing No.	Basic Load Ratings kN		Factor f_0	Mass kg	
	H	L	A	J	N	N_1	H_1	H_2	L_1	B_1	S					C_r	C_{0r}			
12 15 17	1/2 5/8	1 3/16	5	1 1/2	3 3/4	1/2	23/32	5/8	2 3/8	1 13/32	1.720	0.673	3/8 M10	NAP201 NAP201-8 NAP202 NAP202-10 NAP203	P203	NA201 NA201-8 NA202 NA202-10 NA203	12.8	6.65	13.2	0.71
		30.2	127	38	95	13	18	16	60	36	43.7	17.1								0.69
20	3/4	1 5/16	5	1 1/2	3 3/4	1/2	23/32	5/8	2 9/16	1 13/32	1.720	0.673	3/8 M10	NAP204-12 NAP204	P204	NA204-12 NA204	12.8	6.65	13.2	0.73
		33.3	127	38	95	13	18	16	65	36	43.7	17.1								0.73
25	7/8 15/16	1 7/16	5 1/2	1 1/2	4 1/8	1/2	23/32	5/8	2 3/4	1 1/2	1.748	0.689	3/8 M10	NAP205-14 NAP205-15 NAP205 NAP205-16	P205	NA205-14 NA205-15 NA205 NA205-16	14.0	7.85	13.9	0.87
		36.5	140	38	105	13	18	16	70	38	44.4	17.5								0.87
30	1 1/8 1 3/16 1 1/4	1 11/16	6 1/2	1 7/8	4 3/4	21/32	13/16	21/32	3 5/16	1 7/8	1.906	0.720	1/2 M14	NAP206-18 NAP206 NAP206-19 NAP206-20	P206	NA206-18 NA206 NA206-19 NA206-20	19.5	11.3	13.9	1.4
		42.9	165	48	121	17	21	17	84	48	48.4	18.3								1.4
35	1 1/4 1 5/16 1 3/8	1 7/8	6 9/16	1 7/8	5	21/32	13/16	23/32	3 3/4	1 27/32	2.012	0.740	1/2 M14	NAP207-20 NAP207-21 NAP207-22 NAP207 NAP207-23	P207	NA207-20 NA207-21 NA207-22 NA207 NA207-23	25.7	15.4	13.9	1.8
		47.6	167	48	127	17	21	18	95	47	51.1	18.8								1.8
40	1 1/2 1 9/16	1 15/16	7 1/4	2 1/8	5 13/32	21/32	13/16	23/32	3 27/32	2 3/32	2.217	0.843	1/2 M14	NAP208-24 NAP208-25 NAP208	P208	NA208-24 NA208-25 NA208	29.1	17.8	14.0	2.1
		49.2	184	54	137	17	21	18	98	53	56.3	21.4								2.1
45	1 5/8 1 11/16 1 3/4	2 1/8	7 15/32	2 1/8	5 3/4	21/32	13/16	25/32	4 3/16	2 5/32	2.217	0.843	1/2 M14	NAP209-26 NAP209-27 NAP209-28 NAP209	P209	NA209-26 NA209-27 NA209-28 NA209	34.1	21.3	14.0	2.4
		54	190	54	146	17	21	20	106	55	56.3	21.4								2.4
50	1 7/8 1 15/16 2	2 1/4	8 1/8	2 3/8	6 1/4	25/32	7/8	13/16	4 7/16	2 3/8	2.469	0.969	5/8 M16	NAP210-30 NAP210-31 NAP210 NAP210-32	P210	NA210-30 NA210-31 NA210 NA210-32	35.1	23.3	14.4	3.1
		57.2	206	60	159	20	22	21	113	60	62.7	24.6								3.1
55	2 2 1/8 2 3/16	2 1/2	8 5/8	2 3/8	6 23/32	25/32	7/8	29/32	4 29/32	2 9/16	2.811	1.094	5/8 M16	NAP211-32 NAP211-34 NAP211 NAP211-35	P211	NA211-32 NA211-34 NA211 NA211-35	43.4	29.4	14.4	3.9
		63.5	219	60	171	20	22	23	125	65	71.4	27.8								3.9
60	2 1/4 2 3/8 2 7/16	2 3/4	9 1/2	2 3/4	7 1/4	25/32	31/32	31/32	5 7/16	2 7/8	3.063	1.220	5/8 M16	NAP212-36 NAP212 NAP212-38 NAP212-39	P212	NA212-36 NA212 NA212-38 NA212-39	52.4	36.2	14.4	5.2
		69.8	241	70	184	20	25	25	138	73	77.8	31								5.2
65	2 1/2 2 3/4	3	10 7/16	2 3/4	8	31/32	1 3/16	1 1/16	5 29/32	3 1/16	3.374	1.343	3/4 M20	NAP213-40 NAP213	P213	NA213-40 NA213	57.2	40.1	14.4	6.5
		76.2	265	70	203	25	30	27	150	78	85.7	34.1								6.5
70	2 3/4 2 7/16	3 1/8	10 15/32	2 27/32	8 9/32	31/32	1 3/16	1 1/16	6 3/16	2 15/16	3.374	1.343	3/4 M20	NAP214-44 NAP214	P214	NA214-44 NA214	62.2	44.1	14.5	7.7
		79.4	266	72	210	25	30	27	157	75	85.7	34.1								7.7
75	2 15/16 2 7/8	3 1/4	10 13/16	2 29/32	8 17/32	31/32	1 3/16	1 3/32	6 3/8	3 1/16	3.626	1.469	3/4 M20	NAP215-47 NAP215	P215	NA215-47 NA215	67.4	48.3	14.5	7.9
		82.6	275	74	217	25	30	28	162	78	92.1	37.3								7.9

Remarks 1. In Part No. of unit, fitting codes follow bore diameter numbers. (See Table 10.5 in P.62.)
2. Part No. of applicable grease fittings are shown below.
A-1/4-28UNF 201~210
A-R1/8 211~215

3. As for the triple seal type product (from 201 to 205 are the double seal type products), suffix code L3 (or L2) follows the Part No. of unit or bearing. (Example of Part No.: NAP206JL3, NA206L3)
4. For the dimensions and forms of applicable bearings, see the dimensional tables of ball bearing for unit.
5. Representative examples of the forms of housing are indicated.
6. Housings of nodular graphite cast iron are also available.

NAP-E
Cylindrical bore
(with eccentric locking collar)
 $d \ 1 \frac{3}{16} \sim 2 \frac{15}{16}$ inch

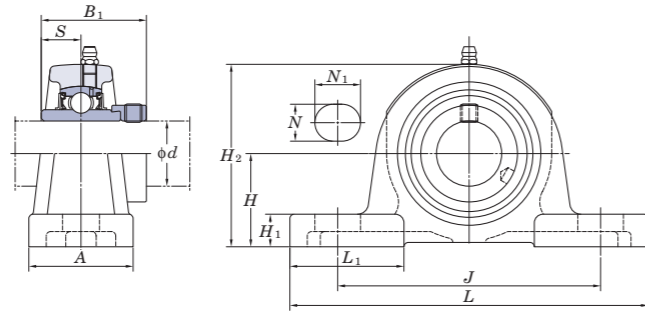

Variations of tolerance of distance from mounting bottom to center of spherical bore (ΔH_2)

Housing No.	Unit: mm ΔH_2
P306E~P310E	±0.15
P311E~P315E	±0.2

Shaft Dia. inch d	Dimensions inch mm												Bolt Size inch mm	Unit No.	Housing No.	Bearing No.	Basic Load Ratings kN		Factor f_0	Mass kg
	H	L	A	J	N	N_1	H_1	H_2	L_1	B_1	S	C_r					C_{0r}			
	$1 \frac{3}{16}$	$1 \frac{7}{8}$ 47.6	$7 \frac{3}{32}$ 180	$1 \frac{31}{32}$ 50	$5 \frac{1}{2}$ 140	$2 \frac{1}{32}$ 17	$2 \frac{5}{32}$ 20	$\frac{9}{16}$ 14.6	$3 \frac{21}{32}$ 92.6	$2 \frac{3}{32}$ 53	1.969 50	0.689 17.5					$\frac{1}{2}$ M14	NAP306-19E		
$1 \frac{7}{16}$	$2 \frac{1}{8}$ 54	$8 \frac{9}{32}$ 210	$2 \frac{7}{32}$ 56	$6 \frac{5}{16}$ 160	$2 \frac{1}{32}$ 17	$3 \frac{1}{32}$ 25	$2 \frac{1}{32}$ 17	$4 \frac{1}{8}$ 105	$2 \frac{9}{16}$ 65	2.031 51.6	0.720 18.3	$\frac{1}{2}$ M14	NAP307-23E	P307E	NA307-23	33.4	19.3	13.2	3.1	
$1 \frac{1}{2}$	$2 \frac{3}{8}$ 60.3	$8 \frac{21}{32}$ 220	$2 \frac{3}{8}$ 60	$6 \frac{11}{16}$ 170	$2 \frac{1}{32}$ 17	$1 \frac{1}{16}$ 27	$\frac{3}{4}$ 19.3	$4 \frac{21}{32}$ 118.3	$2 \frac{9}{16}$ 65	2.248 57.1	0.780 19.8	$\frac{1}{2}$ M14	NAP308-24E	P308E	NA308-24	40.7	24.0	13.2	4.1	
$1 \frac{11}{16}$	$2 \frac{5}{8}$ 66.7	$9 \frac{21}{32}$ 245	$2 \frac{5}{8}$ 67	$7 \frac{15}{32}$ 190	$2 \frac{5}{32}$ 20	$1 \frac{3}{16}$ 30	$\frac{13}{16}$ 20.7	$5 \frac{3}{16}$ 131.7	$2 \frac{15}{16}$ 75	2.311 58.7	0.780 19.8	$\frac{5}{8}$ M16	NAP309-27E	P309E	NA309-27	48.9	29.5	13.3	5.1	
$1 \frac{15}{16}$	$2 \frac{13}{16}$ 71.4	$10 \frac{13}{16}$ 275	$2 \frac{15}{16}$ 75	$8 \frac{11}{32}$ 212	$2 \frac{5}{32}$ 20	$1 \frac{3}{8}$ 35	$\frac{13}{16}$ 20.4	$5 \frac{11}{16}$ 144.4	$3 \frac{15}{32}$ 88	2.622 66.6	0.969 24.6	$\frac{5}{8}$ M16	NAP310-31E	P310E	NA310-31	62.0	38.3	13.2	7	
$2 \frac{3}{16}$	$3 \frac{1}{16}$ 77.8	$12 \frac{7}{32}$ 310	$3 \frac{5}{32}$ 80	$9 \frac{9}{32}$ 236	$2 \frac{5}{32}$ 20	$1 \frac{1}{2}$ 38	$\frac{31}{32}$ 24.8	$6 \frac{1}{8}$ 155.8	$3 \frac{17}{32}$ 90	2.874 73	1.094 27.8	$\frac{5}{8}$ M16	NAP311-35E	P311E	NA311-35	71.6	45.0	13.2	8.5	
$2 \frac{7}{16}$	$3 \frac{5}{16}$ 84.1	13 330	$3 \frac{11}{32}$ 85	$9 \frac{27}{32}$ 250	$3 \frac{1}{32}$ 25	$1 \frac{1}{2}$ 38	$1 \frac{3}{32}$ 28.1	$6 \frac{17}{32}$ 166.1	$4 \frac{1}{16}$ 103	3.126 79.4	1.220 31	$\frac{3}{4}$ M20	NAP312-39E	P312E	NA312-39	81.9	52.2	13.2	10.1	
$2 \frac{11}{16}$	$3 \frac{13}{16}$ 96.8	$14 \frac{3}{16}$ 360	$3 \frac{17}{32}$ 90	$11 \frac{1}{32}$ 280	$1 \frac{1}{16}$ 27	$1 \frac{9}{16}$ 40	$1 \frac{7}{16}$ 36.8	$7 \frac{13}{32}$ 187.8	$4 \frac{11}{32}$ 110	3.626 92.1	1.343 34.1	$\frac{7}{8}$ M22	NAP314-43E	P314E	NA314-43	104	68.2	13.2	13.8	
$2 \frac{15}{16}$	$4 \frac{1}{8}$ 104.8	$14 \frac{31}{32}$ 380	$3 \frac{15}{16}$ 100	$11 \frac{13}{32}$ 290	$1 \frac{1}{16}$ 27	$1 \frac{23}{32}$ 44	$1 \frac{9}{16}$ 39.8	$7 \frac{31}{32}$ 202.8	$4 \frac{7}{32}$ 107	3.937 100	1.469 37.3	$\frac{7}{8}$ M22	NAP315-47E	P315E	NA315-47	113	77.2	13.2	16.8	

Remarks 1. In Part No. of unit, fitting codes follow bore diameter numbers. (See Table 10.5 in P.62.)
 2. Part No. of applicable grease fittings are shown below.
 A-1/4-28UNF 306~308
 A-R1/8 309~315

3. As for the triple seal type product (from 201 to 205 are the double seal type products), suffix code L3 (or L2) follows the Part No. of unit or bearing.
 (Example of Part No. : NAP306JEL3, NA306L3)
 4. For the dimensions and forms of applicable bearings, see the dimensional tables of ball bearing for unit.
 5. Representative examples of the forms of housing are indicated.
 6. Housings of nodular graphite cast iron are also available.

NCP
Cylindrical bore
(with concentric locking collar)
d 20 ~ 60 mm

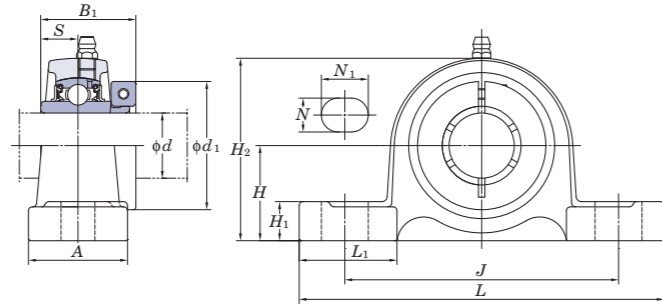

Variations of tolerance of distance from mounting bottom to center of spherical bore (ΔH_s)

Housing No.	Unit: mm ΔH_s
P204~P210	±0.15
P211~P212	±0.2

Shaft Dia. mm <i>d</i>	inch	Dimensions inch mm											Bolt Size inch mm	Unit No.	Housing No.	Bearing No.	Basic Load Ratings kN		Factor <i>f</i> ₀	Mass kg	
		<i>H</i>	<i>L</i>	<i>A</i>	<i>J</i>	<i>N</i>	<i>N</i> ₁	<i>H</i> ₁	<i>H</i> ₂	<i>L</i> ₁	<i>B</i> ₁	<i>S</i>					<i>d</i> ₁	<i>C</i> _r			<i>C</i> _{0r}
20	3/4	1 5/16	5	1 1/2	3 3/4	1/2	23/32	5/8	2 9/16	1 13/32	1 9/32	0.500	1 3/4	3/8	NCP204-12 NCP204	P204	NC204-12 NC204	12.8	6.65	13.2	0.8
	33.3	127	38	95	13	18	16	65	36	32.5	12.7	44.5	M10								
25	7/8	1 7/16	5 1/2	1 1/2	4 1/8	1/2	23/32	5/8	2 3/4	1 1/2	1 7/16	0.563	1 15/16	3/8	NCP205-14 NCP205-15 NCP205 NCP205-16	P205	NC205-14 NC205-15 NC205 NC205-16	14.0	7.85	13.9	1.0
	15/16																				
30	1 1/8	1 11/16	6 1/2	1 7/8	4 3/4	21/32	13/16	21/32	3 5/16	1 7/8	1 9/16	0.626	2 3/16	1/2	NCP206-18 NCP206 NCP206-19 NCP206-20	P206	NC206-18 NC206 NC206-19 NC206-20	19.5	11.3	13.9	1.5
	1 3/16																				
35	1 1/4	1 7/8	6 9/16	1 7/8	5	21/32	13/16	23/32	3 3/4	1 27/32	1 3/4	0.689	2 7/16	1/2	NCP207-20 NCP207-22 NCP207 NCP207-23	P207	NC207-20 NC207-22 NC207 NC207-23	25.7	15.4	13.9	1.9
	1 3/8																				
40	1 1/2	1 15/16	7 1/4	2 1/8	5 13/32	21/32	13/16	23/32	3 27/32	2 3/32	2	0.748	2 11/16	1/2	NCP208-24 NCP208	P208	NC208-24 NC208	29.1	17.8	14.0	2.4
	49.2																				
45	1 5/8	2 1/8	7 15/32	2 1/8	5 3/4	21/32	13/16	25/32	4 3/16	2 5/32	2	0.748	2 13/16	1/2	NCP209-26 NCP209-27 NCP209-28 NCP209	P209	NC209-26 NC209-27 NC209-28 NC209	34.1	21.3	14.0	2.6
	54																				
50	1 15/16	2 1/4	8 1/8	2 3/8	6 1/4	25/32	7/8	13/16	4 7/16	2 3/8	2 3/32	0.748	3 3/8	5/8	NCP210-31 NCP210 NCP210-32	P210	NC210-31 NC210 NC210-32	35.1	23.3	14.4	3.5
	2																				
55	2	2 1/2	8 5/8	2 3/8	6 23/32	25/32	7/8	29/32	4 29/32	2 9/16	2 1/4	0.874	3 1/2	5/8	NCP211-32 NCP211 NCP211-35	P211	NC211-32 NC211 NC211-35	43.4	29.4	14.4	4.0
	63.5																				
60	2 3/16	2 3/4	9 1/2	2 3/4	7 1/4	25/32	31/32	31/32	5 7/16	2 7/8	2 5/8	1.000	4 1/16	5/8	NCP212-36 NCP212 NCP212-39	P212	NC212-36 NC212 NC212-39	52.4	36.2	14.4	5.6
	69.8																				
	2 7/16	69.8	241	70	184	20	25	25	138	73	66.7	25.4	104.8	M16				52.4	36.2	14.4	5.6

Remarks 1. In Part No. of unit, fitting codes follow bore diameter codes. (See Table 10.5 in P.62.)
2. Part No. of applicable grease fittings are shown below.
A-1/4-28UNF 204~210
A-R1/8 211~212

3. For the dimensions and forms of applicable bearings, see the dimensional tables of ball bearing for unit.
4. Representative examples of the forms of housing are indicated.

UKP
Tapered bore (with adapter)
 d_1 (90) ~ 125 mm

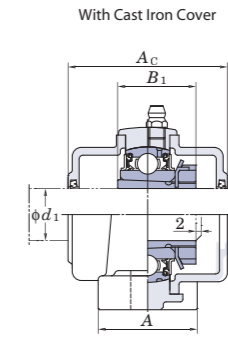
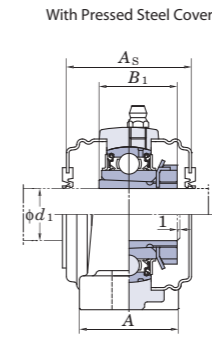
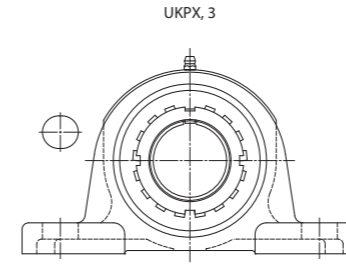
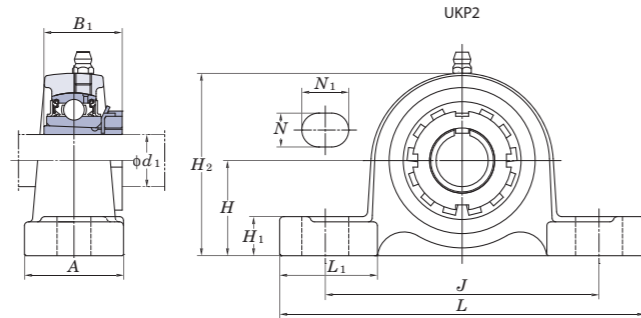

Variations of tolerance of distance from mounting bottom to center of spherical bore (ΔH_{2c})

Housing No.		Unit: mm
P205~P210	PX05~PX10	±0.15
P211~P218	PX11~PX18	±0.2
PX20	P319~P328	±0.3

Forms and dimensions of H_{2c} of P205JE3 (housing with cast iron cover) are shown below.

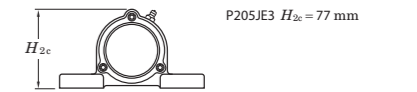

Shaft Dia. mm inch	Dimensions inch mm											Bolt Size inch mm	Standard			Adapter No.	Mass kg	Basic Load Ratings kN		Factor f_0	With Pressed Steel Cover			With Cast Iron Cover		
	H	L	A	J	N	N_1	H_1	H_2	L_1	B_1	Unit No.		Housing No.	Bearing No.	Unit No.			Dimension mm inch	Mass kg		Unit No.	Dimension mm inch	Mass kg			
90 3 1/2	5 33/64	19 9/32	4 23/32	14 31/32	1 13/32	1 31/32	1 13/16	10 3/4	5 1/2	3 13/16	1 1/8	UKP320	P320	UK320	HE2320X H2320X	34.8 34.8	173 141	13.2	—	—	—	—	—	—		
	140	490	120	380	36	50	46	273	140	97	—								—	—	—	—	—	—	—	—
100 4	5 29/32	20 15/32	5 1/2	15 3/4	1 9/16	2 5/32	1 31/32	11 21/32	5 29/32	4 1/8	1 1/4	UKP322	P322	UK322	H2322X HE2322X	43.9 43.9	205 180	13.2	—	—	—	—	—	—		
	150	520	140	400	40	55	50	296	150	105	—								—	—	—	—	—	—	—	—
110 —	6 19/64	22 7/16	5 1/2	17 23/32	1 9/16	2 5/32	1 31/32	12 7/16	6 5/16	4 13/32	1 1/4	UKP324	P324	UK324	H2324	55.7	207 185	13.5	—	—	—	—	—	—		
	160	570	140	450	40	55	50	316	160	112	—								—	—	—	—	—	—	—	—
115 4 1/2	7 3/32	23 5/8	5 1/2	18 29/32	1 9/16	2 5/32	1 31/32	13 21/32	7 11/16	4 3/4	1 1/4	UKP326	P326	UK326	HE2326 H2326	71.9 71.9	229 214	13.6	—	—	—	—	—	—		
	180	600	140	480	40	55	50	355	195	121	—								—	—	—	—	—	—	—	—
125 —	7 7/8	24 13/32	5 1/2	19 11/16	1 9/16	2 5/32	2 3/8	15 15/32	7 9/32	5 5/32	1 1/4	UKP328	P328	UK328	H2328	92.5	253 246	13.6	—	—	—	—	—	—		
	200	620	140	500	40	55	60	393	185	131	—								—	—	—	—	—	—	—	—

Remarks 1. In Part No. of unit and units with covers, fitting codes follow bore diameter numbers. (See Table 10.5 in P.62.)
 2. Part No. of applicable grease fittings are shown below.
 A-1/4-28UNF 205~210, X05~X09, 305~308
 A-R1/8 211~218, X10~X20, 309~328

3. In Part No. of unit with adapters and bearing with adapters, Part No. of applicable adapter follow the Part No. shown in the dimensional tables.
 (Example of Part No. : UKP206J + H2306X, UK206 + H2306X)
 4. As for the triple seal type product (205 is the double seal type product), suffix code L3 (or L2) follows the Part No. of unit or bearing.
 5. For the dimensions and forms of applicable bearings and adapters, see the dimensional tables of ball bearing for unit and adapter.
 6. Representative examples of the forms of housing are indicated.
 7. Housings of nodular graphite cast iron are also available.

UCPA
Cylindrical bore (with set screws)
 d 12 ~ 50 mm

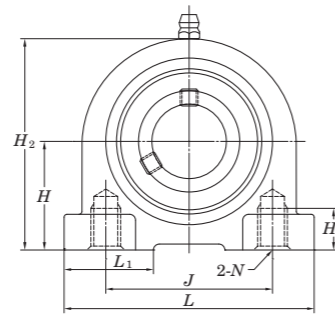
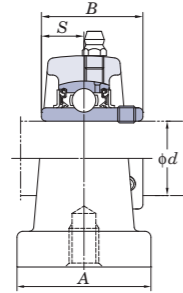

Variations of tolerance of distance from mounting bottom to center of spherical bore (ΔH_s) and variations of tolerance of distance between centers of bolt holes (ΔL_s)

Housing No.	ΔH_s	ΔL_s
PA204~PA210	± 0.15	± 0.5

Unit: mm

Shaft Dia. mm inch d	Dimensions inch mm										Unit No.	Housing No.	Bearing No.	Basic Load Ratings kN		Factor f_0	Mass kg
	H	L	A	J	N	H_2	H_3	L_1	B	S				C_r	C_{0r}		
12 1/2											UCPA201 UCPA201-8 UCPA202 UCPA202-10 UCPA203 UCPA204-12 UCPA204	PA204	UC201 UC201-8 UC202 UC202-10 UC203 UC204-12 UC204	12.8	6.65	13.2	0.64 0.62 0.61 0.59
15 5/8	1 3/16 30.2	3 76	1 9/16 40	2 3/64 52	M10x1.5	2 3/8 60	1/2 13	1 1/16 27	1.220 31	0.500 12.7	UCPA205-14 UCPA205-15 UCPA205 UCPA205-16 UCPA206-18 UCPA206 UCPA206-19 UCPA206-20	PA205	UC205-14 UC205-15 UC205 UC205-16 UC206-18 UC206 UC206-19 UC206-20	14.0	7.85	13.9	0.83
17 3/4											UCPA205-14 UCPA205-15 UCPA205 UCPA205-16 UCPA206-18 UCPA206 UCPA206-19 UCPA206-20	PA205	UC205-14 UC205-15 UC205 UC205-16 UC206-18 UC206 UC206-19 UC206-20	14.0	7.85	13.9	0.83
20											UCPA205-14 UCPA205-15 UCPA205 UCPA205-16 UCPA206-18 UCPA206 UCPA206-19 UCPA206-20	PA205	UC205-14 UC205-15 UC205 UC205-16 UC206-18 UC206 UC206-19 UC206-20	14.0	7.85	13.9	0.83
25 7/8 15/16	1 7/16 36.5	3 5/16 84	1 25/32 45	2 13/64 56	M10x1.5	2 25/32 71	1/2 13	1 3/16 30	1.343 34.1	0.563 14.3	UCPA207-20 UCPA207-21 UCPA207-22 UCPA207 UCPA207-23 UCPA208-24 UCPA208-25 UCPA208	PA207	UC207-20 UC207-21 UC207-22 UC207 UC207-23 UC208-24 UC208-25 UC208	25.7	15.4	13.9	1.7
25											UCPA207-20 UCPA207-21 UCPA207-22 UCPA207 UCPA207-23 UCPA208-24 UCPA208-25 UCPA208	PA207	UC207-20 UC207-21 UC207-22 UC207 UC207-23 UC208-24 UC208-25 UC208	25.7	15.4	13.9	1.7
30 1 1/8 1 3/16 1 1/4	1 11/16 42.9	3 11/16 94	1 31/32 50	2 19/32 66	M14x2	3 5/16 84	23/32 18	1 13/32 36	1.500 38.1	0.626 15.9	UCPA209-26 UCPA209-27 UCPA209-28 UCPA209	PA209	UC209-26 UC209-27 UC209-28 UC209	34.1	21.3	14.0	2.2
30											UCPA209-26 UCPA209-27 UCPA209-28 UCPA209	PA209	UC209-26 UC209-27 UC209-28 UC209	34.1	21.3	14.0	2.2
35 1 1/4 1 5/16 1 3/8	1 7/8 47.6	4 11/32 110	2 5/32 55	3 5/32 80	M14x2	3 21/32 93	25/32 20	1 5/8 41	1.689 42.9	0.689 17.5	UCPA210-30 UCPA210-31 UCPA210 UCPA210-32	PA210	UC210-30 UC210-31 UC210 UC210-32	35.1	23.3	14.4	2.8
35											UCPA210-30 UCPA210-31 UCPA210 UCPA210-32	PA210	UC210-30 UC210-31 UC210 UC210-32	35.1	23.3	14.4	2.8
40 1 1/2 1 9/16	1 15/16 49.2	4 9/16 116	2 9/32 58	3 5/16 84	M14x2	3 27/32 98	25/32 20	1 5/8 41	1.937 49.2	0.748 19	UCPA210-30 UCPA210-31 UCPA210 UCPA210-32	PA210	UC210-30 UC210-31 UC210 UC210-32	35.1	23.3	14.4	2.8
40											UCPA210-30 UCPA210-31 UCPA210 UCPA210-32	PA210	UC210-30 UC210-31 UC210 UC210-32	35.1	23.3	14.4	2.8
45 1 5/8 1 11/16 1 3/4	2 9/64 54.2	4 23/32 120	2 3/8 60	3 35/64 90	M14x2	4 3/16 106	31/32 25	1 21/32 42	1.937 49.2	0.748 19	UCPA210-30 UCPA210-31 UCPA210 UCPA210-32	PA210	UC210-30 UC210-31 UC210 UC210-32	35.1	23.3	14.4	2.8
45											UCPA210-30 UCPA210-31 UCPA210 UCPA210-32	PA210	UC210-30 UC210-31 UC210 UC210-32	35.1	23.3	14.4	2.8
50 1 7/8 1 15/16	2 1/4 57.2	5 1/8 130	2 17/32 64	3 45/64 94	M16x2	4 7/16 113	31/32 25	1 27/32 47	2.031 51.6	0.748 19	UCPA210-30 UCPA210-31 UCPA210 UCPA210-32	PA210	UC210-30 UC210-31 UC210 UC210-32	35.1	23.3	14.4	2.8
50											UCPA210-30 UCPA210-31 UCPA210 UCPA210-32	PA210	UC210-30 UC210-31 UC210 UC210-32	35.1	23.3	14.4	2.8

Remarks 1. In Part No. of unit, fitting codes follow bore diameter codes. (See Table 10.5 in P.62.)
2. Part No. of the applicable grease fitting is A-1/4-28UNF.
3. As for the triple seal type product (from 201 to 205 are the double seal type products), suffix code L3 (or L2) follows Part No. of unit or bearing. (Example of Part No. : UCPA206JL3, UC206L3)

4. As for the dimensions and forms of applicable bearings, see the dimensional tables of ball bearing for unit.
5. Tapered bore (with adapter) type products are also available. (Example of Part No. : UKPA205J + H2305X, UK205 + H2305X)
6. Housings of nodular graphite cast iron are also available.

UCPAN
Cylindrical bore (with set screws)
 d 20 ~ 35 mm

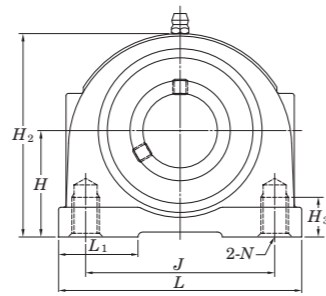
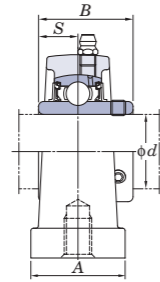

Variations of tolerance of distance from mounting bottom to center of spherical bore (ΔH_s) and variations of tolerance of distance between centers of bolt holes (ΔL_s)

Unit: mm		
Housing No.	ΔH_s	ΔL_s
PAN204~PAN207	± 0.15	± 0.5

Shaft Dia. mm inch d	Dimensions inch mm											Unit No.	Housing No.	Bearing No.	Basic Load Ratings kN		Factor f_0	Mass kg
	H	L	A	J	N	H_2	H_3	L_1	B	S	C_r				C_{0r}			
20 $\frac{3}{4}$	$1 \frac{5}{16}$ 33.3	$2 \frac{9}{16}$ 65	$1 \frac{1}{4}$ 32	2 50.8	$\frac{3}{8}$ -16UNC	$2 \frac{17}{32}$ 64	$\frac{1}{2}$ 12.7	$\frac{7}{8}$ 22	1.220 31	0.500 12.7	UCPAN204-12 UCPAN204	PAN204	UC204-12 UC204	12.8	6.65	13.2	0.55	
	25 $\frac{7}{8}$ $\frac{15}{16}$	$1 \frac{7}{16}$ 36.5	$2 \frac{3}{4}$ 70	$1 \frac{13}{32}$ 36	2 50.8	$\frac{3}{8}$ -16UNC	$2 \frac{3}{4}$ 70	$\frac{1}{2}$ 13	$\frac{15}{16}$ 24	1.343 34.1								0.563 14.3
30 $1 \frac{1}{8}$ $1 \frac{3}{16}$ $1 \frac{1}{4}$	$1 \frac{11}{16}$ 42.9	$3 \frac{27}{32}$ 98	$1 \frac{1}{2}$ 38	3 76.2	$\frac{7}{16}$ -14UNC	$3 \frac{7}{32}$ 82	$\frac{5}{8}$ 16	$1 \frac{11}{32}$ 34	1.500 38.1	0.626 15.9	UCPAN206-18 UCPAN206 UCPAN206-19 UCPAN206-20	PAN206	UC206-18 UC206 UC206-19 UC206-20	19.5	11.3	13.9	1.3	
	35 $1 \frac{1}{4}$ $1 \frac{5}{16}$ $1 \frac{3}{8}$ $1 \frac{7}{16}$	$1 \frac{7}{8}$ 47.6	$4 \frac{11}{32}$ 110	$1 \frac{7}{8}$ 48	$3 \frac{1}{4}$ 82.6	$\frac{1}{2}$ -13UNC	$3 \frac{21}{32}$ 93	$\frac{3}{4}$ 19	$1 \frac{3}{32}$ 28	1.689 42.9								0.689 17.5

Remarks 1. In Part No. of unit, fitting codes follow bore diameter codes. (See Table 10.5 in P.62.)
2. Part No. of the applicable grease fitting is A-1/4-28UNF.
3. As for the triple seal type product (from 201 to 205 are the double seal type products), suffix code L3 (or L2) follows Part No. of unit or bearing. (Example of Part No.: UCPAN206L3, UC206L3)

4. As for the dimensions and forms of applicable bearings, see the dimensional tables of ball bearing for unit.
5. Tapered bore (with adapter) type products are also available. (Example of Part No.: UKPAN205J + H2305X, UK205 + H2305X)
6. Housings of nodular graphite cast iron are also available.

NCPA
Cylindrical bore
(with concentric locking collar)
d 20 ~ 50 mm

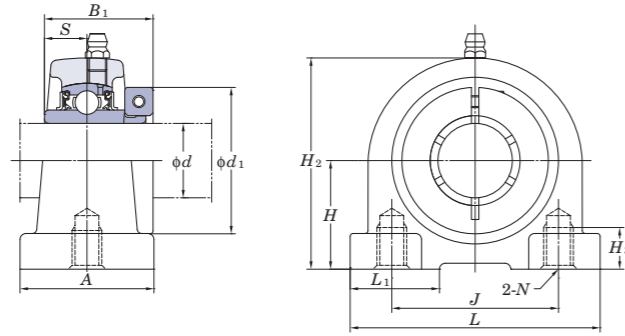

Variations of tolerance of distance from mounting bottom to center of spherical bore (ΔH_s) and variations of tolerance of distance between centers of bolt holes (ΔL_s)

Unit: mm		
Housing No.	ΔH_s	ΔL_s
PA204~PA210	±0.15	±0.5

Shaft Dia. mm inch <i>d</i>	Dimensions inch mm											Unit No.	Housing No.	Bearing No.	Basic Load Ratings kN		Factor <i>f</i> ₀	Mass kg
	<i>H</i>	<i>L</i>	<i>A</i>	<i>J</i>	<i>N</i>	<i>H</i> ₂	<i>H</i> ₃	<i>L</i> ₁	<i>B</i> ₁	<i>S</i>	<i>d</i> ₁				<i>C</i> _r	<i>C</i> _{0r}		
20 ^{3/4}	1 ^{3/16}	3	1 ^{9/16}	2 ^{3/64}	M10×1.5	2 ^{3/8}	1/2	1 ^{1/16}	1 ^{9/32}	0.500	1 ^{3/4}	NCPA204-12 NCPA204	PA204	NC204-12 NC204	12.8	6.65	13.2	0.73
	30.2	76	40	52	60	13	27	32.5	12.7	44.5								
25 ^{7/8} ^{15/16}	1 ^{7/16}	3 ^{5/16}	1 ^{25/32}	2 ^{13/64}	M10×1.5	2 ^{25/32}	1/2	1 ^{3/16}	1 ^{7/16}	0.563	1 ^{15/16}	NCPA205-14 NCPA205-15 NCPA205 NCPA205-16	PA205	NC205-14 NC205-15 NC205 NC205-16	14.0	7.85	13.9	1.0
	36.5	84	45	56	71	13	30	36.5	14.3	49.2								
	1																	
30 ^{1 1/8} ^{1 3/16} ^{1 1/4}	1 ^{11/16}	3 ^{11/16}	1 ^{31/32}	2 ^{19/32}	M14×2	3 ^{5/16}	^{23/32}	1 ^{13/32}	1 ^{9/16}	0.626	2 ^{3/16}	NCPA206-18 NCPA206 NCPA206-19 NCPA206-20	PA206	NC206-18 NC206 NC206-19 NC206-20	19.5	11.3	13.9	1.4
	42.9	94	50	66	84	18	36	39.7	15.9	55.6								
	1 ^{1/4}																	
35 ^{1 1/4} ^{1 3/8} ^{1 7/16}	1 ^{7/8}	4 ^{11/32}	2 ^{5/32}	3 ^{5/32}	M14×2	3 ^{21/32}	^{25/32}	1 ^{5/8}	1 ^{3/4}	0.689	2 ^{7/16}	NCPA207-20 NCPA207-22 NCPA207 NCPA207-23	PA207	NC207-20 NC207-22 NC207 NC207-23	25.7	15.4	13.9	2.0
	47.6	110	55	80	93	20	41	44.5	17.5	61.9								
	1 ^{3/8}																	
40 ^{1 1/2}	1 ^{15/16}	4 ^{9/16}	2 ^{9/32}	3 ^{5/16}	M14×2	3 ^{27/32}	^{25/32}	1 ^{5/8}	2	0.748	2 ^{11/16}	NCPA208-24 NCPA208	PA208	NC208-24 NC208	29.1	17.8	14.0	2.4
	49.2	116	58	84	98	20	41	50.8	19	68.3								
45 ^{1 5/8} ^{1 11/16} ^{1 3/4}	2 ^{9/64}	4 ^{23/32}	2 ^{3/8}	3 ^{35/64}	M14×2	4 ^{3/16}	^{31/32}	1 ^{21/32}	2	0.748	2 ^{13/16}	NCPA209-26 NCPA209-27 NCPA209-28 NCPA209	PA209	NC209-26 NC209-27 NC209-28 NC209	34.1	21.3	14.0	2.6
	54.2	120	60	90	106	25	42	50.8	19	71.4								
	1 ^{11/16}																	
50 ^{1 15/16} 2	2 ^{1/4}	5 ^{1/8}	2 ^{17/32}	3 ^{45/64}	M16×2	4 ^{7/16}	^{31/32}	1 ^{27/32}	2 ^{3/32}	0.748	3 ^{3/8}	NCPA210-31 NCPA210 NCPA210-32	PA210	NC210-31 NC210 NC210-32	35.1	23.3	14.4	3.4
	57.2	130	64	94	113	25	47	53.1	19	85.7								

Remarks 1. In Part No. of unit, fitting codes follow bore diameter codes. (See Table 10.5 in P.62.)
 2. Part No. of the applicable grease fitting is A-1/4-28UNF.
 3. As for the dimensions and forms of applicable bearings, see the dimensional tables of ball bearing for unit.

NCPAN
Cylindrical bore
(with concentric locking collar)
 d 20 ~ 35 mm

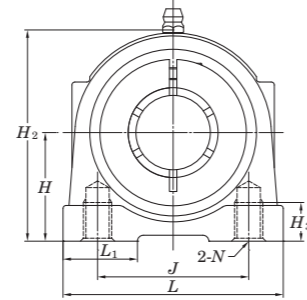
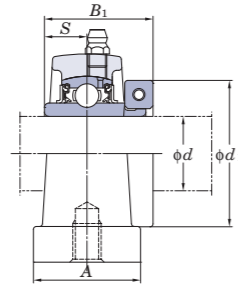

Variations of tolerance of distance from mounting bottom to center of spherical bore (ΔH_s) and variations of tolerance of distance between centers of bolt holes (ΔL_s)

Unit: mm		
Housing No.	ΔH_s	ΔL_s
PAN204~PAN207	± 0.15	± 0.5

Shaft Dia. mm inch d	Dimensions inch mm												Unit No.	Housing No.	Bearing No.	Basic Load Ratings kN		Factor f_0	Mass kg
	H	L	A	J	N	H_2	H_3	L_1	B_1	S	d_1	C_r				C_{0r}			
20 $\frac{3}{4}$	$1 \frac{5}{16}$	$2 \frac{9}{16}$	$1 \frac{1}{4}$	2	$\frac{3}{8}$ -16UNC	$2 \frac{17}{32}$	$\frac{1}{2}$	$\frac{7}{8}$	$1 \frac{9}{32}$	0.500	$1 \frac{3}{4}$	NCPAN204-12 NCPAN204	PAN204	NC204-12 NC204	12.8	6.65	13.2	0.7	
	33.3	65	32	50.8		64	12.7	22	32.5	12.7	44.5								
25 $\frac{7}{8}$ $\frac{15}{16}$	$1 \frac{7}{16}$	$2 \frac{3}{4}$	$1 \frac{13}{32}$	2	$\frac{3}{8}$ -16UNC	$2 \frac{3}{4}$	$\frac{1}{2}$	$\frac{15}{16}$	$1 \frac{7}{16}$	0.563	$1 \frac{15}{16}$	NCPAN205-14 NCPAN205-15 NCPAN205 NCPAN205-16	PAN205	NC205-14 NC205-15 NC205 NC205-16	14.0	7.85	13.9	0.85	
	36.5	70	36	50.8		70	13	24	36.5	14.3	49.2								
30 $1 \frac{1}{8}$ $1 \frac{3}{16}$ $1 \frac{1}{4}$	$1 \frac{11}{16}$	$3 \frac{27}{32}$	$1 \frac{1}{2}$	3	$\frac{7}{16}$ -14UNC	$3 \frac{7}{32}$	$\frac{5}{8}$	$1 \frac{11}{32}$	$1 \frac{9}{16}$	0.626	$2 \frac{3}{16}$	NCPAN206-18 NCPAN206 NCPAN206-19 NCPAN206-20	PAN206	NC206-18 NC206 NC206-19 NC206-20	19.5	11.3	13.9	1.5	
	42.9	98	38	76.2		82	16	34	39.7	15.9	55.6								
35 $1 \frac{1}{4}$ $1 \frac{3}{8}$ $1 \frac{7}{16}$	$1 \frac{7}{8}$	$4 \frac{11}{32}$	$1 \frac{7}{8}$	$3 \frac{1}{4}$	$\frac{1}{2}$ -13UNC	$3 \frac{21}{32}$	$\frac{3}{4}$	$1 \frac{3}{32}$	$1 \frac{3}{4}$	0.689	$2 \frac{7}{16}$	NCPAN207-20 NCPAN207-22 NCPAN207 NCPAN207-23	PAN207	NC207-20 NC207-22 NC207 NC207-23	25.7	15.4	13.9	2.1	
	47.6	110	48	82.6		93	19	28	44.5	17.5	61.9								
	$1 \frac{7}{8}$	$4 \frac{11}{32}$	$1 \frac{7}{8}$	$3 \frac{1}{4}$	$\frac{1}{2}$ -13UNC	$3 \frac{21}{32}$	$\frac{3}{4}$	$1 \frac{3}{32}$	$1 \frac{3}{4}$	0.689	$2 \frac{9}{16}$				25.7	15.4	13.9	2.1	
	47.6	110	48	82.6		93	19	28	44.5	17.5	65.1								

Remarks 1. In Part No. of unit, fitting codes follow bore diameter codes. (See Table 10.5 in P.62.)
2. Part No. of the applicable grease fitting is A-1/4-28UNF.
3. As for the dimensions and forms of applicable bearings, see the dimensional tables of ball bearing for unit.

UCPH
Cylindrical bore (with set screws)
 d 12 ~ 50 mm

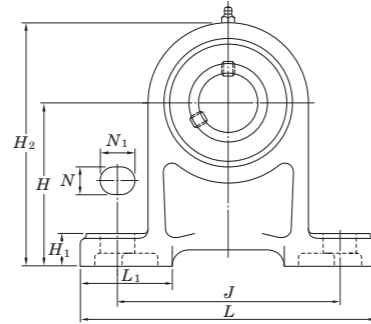
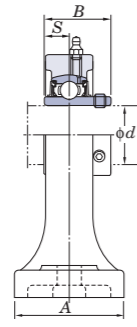

Variations of tolerance of distance from mounting bottom to center of spherical bore (ΔH_s)

Housing No.	Unit: mm ΔH_s
PH204~PH210	±0.15

Shaft Dia. mm d	inch	Dimensions inch mm											Bolt Size inch mm	Unit No.	Housing No.	Bearing No.	Basic Load Ratings kN		Factor f_0	Mass kg			
		H	L	A	J	N	N_1	H_1	H_2	L_1	B	S					C_r	C_{0r}					
12	1/2														M10	UCPH201 UCPH201-8 UCPH202 UCPH202-10 UCPH203 UCPH204-12 UCPH204	UC201 UC201-8 UC202 UC202-10 UC203 UC204-12 UC204	12.8	6.65	13.2	0.96 0.94 0.93 0.91		
15	5/8	2 3/4	5	1 9/16	3 3/4	1/2	3/4	19/32	3 31/32	1 13/16	1.220	0.500			M10								
17	3/4	70	127	40	95	13	19	15	101	46	31	12.7											
20															M10								
25	7/8														M10	UCPH205-14 UCPH205-15 UCPH205 UCPH205-16	UC205-14 UC205-15 UC205 UC205-16	14.0	7.85	13.9	1.2		
	15/16	3 5/32	5 1/2	1 31/32	4 1/8	1/2	3/4	5/8	4 1/2	1 15/16	1.343	0.563											
	1	80	140	50	105	13	19	16	114	49	34.1	14.3											
30	1 1/8														M14	UCPH206-18 UCPH206 UCPH206-19 UCPH206-20	UC206-18 UC206 UC206-19 UC206-20	19.5	11.3	13.9	1.6		
	1 3/16	3 35/64	6 1/2	1 31/32	4 3/4	21/32	13/16	23/32	5 1/8	2 7/32	1.500	0.626											
	1 1/4	90	165	50	121	17	21	18	130	56	38.1	15.9											
35	1 1/4														M14	UCPH207-20 UCPH207-21 UCPH207-22 UCPH207 UCPH207-23	UC207-20 UC207-21 UC207-22 UC207 UC207-23	25.7	15.4	13.9	2.0		
	1 5/16	3 47/64	6 9/16	2 3/8	5	21/32	13/16	23/32	5 1/2	2 1/8	1.689	0.689											
	1 3/8	95	167	60	127	17	21	18	140	54	42.9	17.5											
	1 7/16														M14								
40	1 1/2														M14	UCPH208-24 UCPH208-25 UCPH208	UC208-24 UC208-25 UC208	29.1	17.8	14.0	2.7		
	1 9/16	3 15/16	7 1/4	2 3/4	5 13/32	21/32	13/16	25/32	5 29/32	2 1/4	1.937	0.748											
		100	184	70	137	17	21	20	150	57	49.2	19											
45	1 5/8														M14	UCPH209-26 UCPH209-27 UCPH209-28 UCPH209	UC209-26 UC209-27 UC209-28 UC209	34.1	21.3	14.0	3.0		
	1 11/16	4 9/64	7 15/32	2 3/4	5 3/4	21/32	13/16	25/32	6 7/32	2 9/32	1.937	0.748											
	1 3/4	105	190	70	146	17	21	20	158	58	49.2	19											
50	1 7/8														M16	UCPH210-30 UCPH210-31 UCPH210 UCPH210-32	UC210-30 UC210-31 UC210 UC210-32	35.1	23.3	14.4	3.5		
	1 15/16	4 21/64	8 1/8	2 3/4	6 1/4	25/32	7/8	7/8	6 1/2	2 9/16	2.031	0.748											
	2	110	206	70	159	20	22	22	165	65	51.6	19											

Remarks 1. In Part No. of unit, fitting codes follow bore diameter codes. (See Table 10.5 in P.62.)
 2. Part No. of the applicable grease fitting is A-1/4-28UNF.
 3. As for the triple seal type product (from 201 to 205 are the double seal type products), suffix code L3 (or L2) follows Part No. of unit or bearing. (Example of Part No. : UCPH206JL3, UC206L3)

4. As for the dimensions and forms of applicable bearings, see the dimensional tables of ball bearing for unit.
 5. Tapered bore (with adapter) type products are also available. (Example of Part No. : UKPH205J + H2305X, UK205 + H2305X)

SBPAN-RKP8
Cylindrical bore
(with set screws)
d 20 ~ 35 mm

SAPAN-FP9
Cylindrical bore
(with eccentric locking collar)



SBPAN-RKP8



SAPAN-FP9

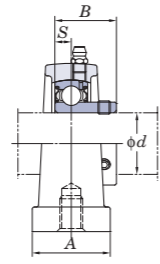

SBPAN-RKP8

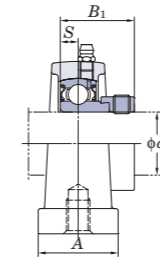
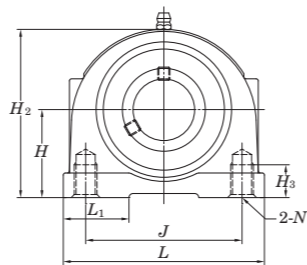

SAPAN-FP9

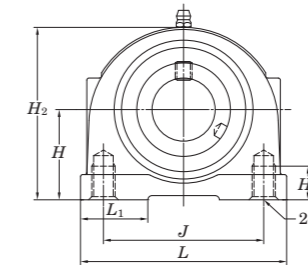

Variations of tolerance of distance from mounting bottom to center of spherical bore (ΔH_s) and variations of tolerance of distance between centers of bolt holes (ΔL_s)

Housing No.	ΔH_s	ΔL_s
PAN204~PAN207	± 0.15	± 0.5

Unit: mm

Shaft Dia. mm inch		Dimensions inch mm											Unit No.	Bearing No.	Unit No.	Bearing No.	Housing No.	Basic Load Ratings kN		Factor	Mass kg		
<i>d</i>		<i>H</i>	<i>L</i>	<i>A</i>	<i>J</i>	<i>N</i>	<i>H</i> ₂	<i>H</i> ₃	<i>L</i> ₁	<i>B</i>	<i>B</i> ₁	SBPAN-RKP8 <i>S</i>	SAPAN-FP9 <i>S</i>					<i>C</i> _r	<i>C</i> _{0r}	<i>f</i> ₀	SBPAN-RKP8	SAPAN-FP9	
20	³ / ₄	1 ⁵ / ₁₆	2 ⁹ / ₁₆	1 ¹ / ₄	2	³ / ₈ -16UNC	2 ¹⁷ / ₃₂	¹ / ₂	⁷ / ₈	0.984	1.220	0.276	0.295	SBPAN204-12RKP8	SB204-12RKP8	SAPAN204-12FP9	SA204-12FP9	PAN204	12.8	6.65	13.2	0.56	0.56
		33.3	65	32	50.8	³ / ₈ -16UNC	64	12.7	22	25	31	7	7.5	SBPAN204RKP8	SB204RKP8	SAPAN204FP9	SA204FP9					0.56	0.56
25	⁷ / ₈	1 ⁷ / ₁₆	2 ³ / ₄	1 ¹³ / ₃₂	2	³ / ₈ -16UNC	2 ³ / ₄	¹ / ₂	¹⁵ / ₁₆	1.063	1.220	0.295	0.295	SBPAN205-14RKP8	SB205-14RKP8	SAPAN205-14FP9	SA205-14FP9	PAN205	14.0	7.85	13.9	0.63	0.63
	SBPAN205-15RKP8													SB205-15RKP8	SAPAN205-15FP9	SA205-15FP9	0.66					0.66	
	SBPAN205-16RKP8													SB205-16RKP8	SAPAN205-16FP9	SA205-16FP9	0.64					0.64	
	SBPAN205RKP8													SB205RKP8	SAPAN205FP9	SA205FP9	0.63					0.63	
30	¹ / ₈	1 ¹¹ / ₁₆	3 ²⁷ / ₃₂	1 ¹ / ₂	3	⁷ / ₁₆ -14UNC	3 ⁷ / ₃₂	⁵ / ₈	1 ¹¹ / ₃₂	1.181	1.906	0.315	0.354	SBPAN206-18RKP8	SB206-18RKP8	SAPAN206-18FP9	SA206-18FP9	PAN206	19.5	11.3	13.9	1.32	1.32
	SBPAN206-19RKP8													SB206-19RKP8	SAPAN206-19FP9	SA206-19FP9	1.34					1.34	
	SBPAN206-20RKP8													SB206-20RKP8	SAPAN206-20FP9	SA206-20FP9	1.32					1.32	
	SBPAN206RKP8													SB206RKP8	SAPAN206FP9	SA206FP9	1.3					1.3	
35	¹ / ₄	1 ⁷ / ₈	4 ¹¹ / ₃₂	1 ⁷ / ₈	3 ¹ / ₄	¹ / ₂ -13UNC	3 ²¹ / ₃₂	³ / ₄	1 ³ / ₃₂	1.260	1.531	0.335	0.374	SBPAN207-20RKP8	SB207-20RKP8	SAPAN207-20FP9	SA207-20FP9	PAN207	25.7	15.4	13.9	1.78	1.78
	SBPAN207-22RKP8													SB207-22RKP8	SAPAN207-22FP9	SA207-22FP9	1.81					1.81	
	SBPAN207-23RKP8													SB207-23RKP8	SAPAN207-23FP9	SA207-23FP9	1.78					1.78	
	SBPAN207RKP8													SB207RKP8	SAPAN207FP9	SA207FP9	1.75					1.75	

Remarks 1. In Part No. of unit, fitting codes follow bore diameter codes. (See Table 10.5 in P.62.)
2. Part No. of the applicable grease fitting is A-1/4-28UNF.

3. As for the dimensions and forms of applicable bearings, see the dimensional tables of ball bearing for unit.
4. Housings of nodular graphite cast iron are also available.

BLP
Cylindrical bore
(with set screws)
 d 12 ~ 40 mm

ALP
Cylindrical bore
(with eccentric locking collar)



BLP

ALP

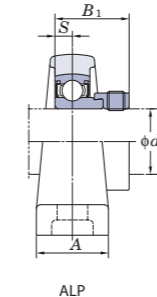
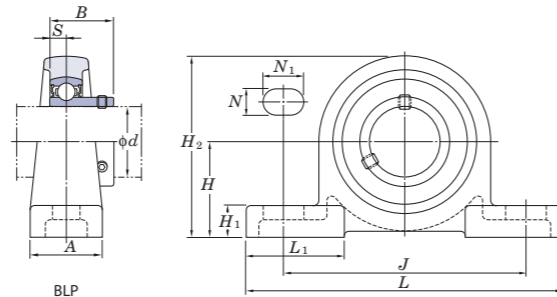

Variations of tolerance of distance from mounting bottom to center of spherical bore (ΔH_2)

Housing No.	Unit: mm ΔH_2
LP203~LP208	± 0.15

Shaft Dia. mm	inch	Dimensions											Bolt Size inch mm	Unit No.	Bearing No.	Unit No.	Bearing No.	Housing No.	Basic Load Ratings kN		Factor f_0	Mass kg		
		H	L	A	J	N	N_1	H_1	H_2	L_1	S	BLP B							ALP B_1	C_r		C_{0r}	BLP	ALP
12	1/2	1 3/16	4 1/2	3 1/32	3 7/16	7/16	5/8	1 5/32	2 1/4	1 3/8	0.236	0.866	1.122	3/8 M10	BLP201 BLP201-8 BLP202 BLP202-10 BLP203	SB201 SB201-8 SB202 SB202-10 SB203	ALP201 ALP201-8 ALP202 ALP202-10 ALP203	SA201 SA201-8 SA202 SA202-10 SA203	LP203	9.55	4.80	13.2	0.36	0.39
		30.2	114	25	87	11	16	12	57	35	6	22	28.5											
		15	5/8																					
17	3/4	1 5/16	4 29/32	1 1/16	3 13/16	7/16	5/8	1/2	2 9/16	1 1/2	0.276	0.984	1.161	3/8 M10	BLP204-12 BLP204	SB204-12 SB204	ALP204-12 ALP204	SA204-12 SA204	LP204	12.8	6.65	13.2	0.51	0.51
		33.3	125	27	97	11	16	13	65	38	7	25	29.5											
		20																						
25	7/8	1 7/16	5 1/8	1 5/32	3 15/16	7/16	5/8	1/2	2 25/32	1 17/32	0.295	1.063	1.201	3/8 M10	BLP205-14 BLP205-15 BLP205 BLP205-16	SB205-14 SB205-15 SB205 SB205-16	ALP205-14 ALP205-15 ALP205 ALP205-16	SA205-14 SA205-15 SA205 SA205-16	LP205	14.0	7.85	13.9	0.57	0.61
		36.5	130	29	100	11	16	13	71	39	7.5	27	30.5											
		25																						
30	1 1/8	1 11/16	6 5/32	1 5/16	4 23/32	9/16	13/16	9/16	3 9/32	1 27/32	0.315	1.181	1.335	1/2 M12	BLP206-18 BLP206 BLP206-19 BLP206-20 BLP207-20	SB206-18 SB206 SB206-19 SB206-20 SB207-20	ALP206-18 ALP206 ALP206-19 ALP206-20 ALP207-20	SA206-18 SA206 SA206-19 SA206-20 SA207-20	LP206	19.5	11.3	13.9	0.69	0.72
		42.9	156	33	120	14	21	14	83	47	8	30	33.9											
		35																						
35	1 1/4	1 7/8	6 1/2	1 3/8	5	9/16	13/16	5/8	3 21/32	1 31/32	0.335	1.260	1.437	1/2 M12	BLP207-22 BLP207 BLP207-23 BLP208-24	SB207-22 SB207 SB207-23 SB208-24	ALP207-21 ALP207-22 ALP207 ALP207-23 ALP208-24	SA207-21 SA207-22 SA207 SA207-23 SA208-24	LP207	25.7	15.4	13.9	0.94	1.0
		47.6	165	35	127	14	21	16	93	50	8.5	32	36.5											
		40																						
40	1 1/2	2	7 1/4	1 15/32	5 1/2	9/16	7/8	23/32	4 1/32	2 5/32	0.354	1.339	1.595	1/2 M12	BLP208	SB208	ALP208-25 ALP208	SA208-25 SA208	LP208	29.1	17.8	14.0	1.8	1.9
		50.8	184	37	140	14	22	18	102	55	9	34	40.5											

Remarks 1. In Part No. of unit, fitting codes follow bore diameter codes. (See Table 10.5 in P.62.)
 2. Allowable load to housing in radial direction is approximately half of basic load rating of bearing, C_r (when safety factor is 4).
 3. For the dimensions and forms of applicable bearings, see the dimensional tables of ball bearing for unit.

UP
Cylindrical bore (with set screws)
 d 10 ~ 30 mm

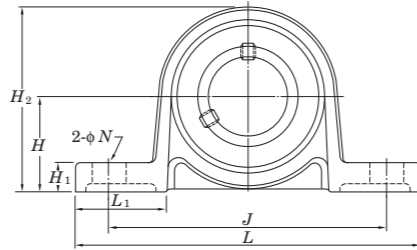
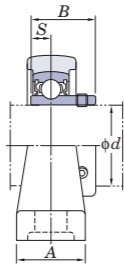

With Through Type Cover

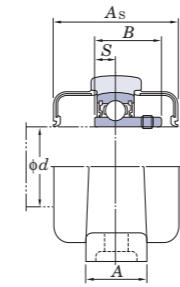

With One Side Sealed Cover

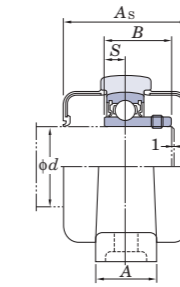

Variations of tolerance of distance from mounting bottom to center of spherical bore (ΔH_s) and variations of tolerance of distance between centers of bolt holes (ΔL_s)

Housing No.	ΔH_s	ΔL_s
P000~P006	± 0.15	± 0.3

Unit: mm

Shaft Dia. mm d	Dimensions inch mm										Bolt Size inch mm	Standard			Mass kg	Basic Load Ratings kN		Factor f_0	With Rubber Coated Cover				
	H	L	A	J	N	H_1	H_2	L_1	B	S		Unit No.	Housing No.	Bearing No.		Open Type	One Side Closed Type		Dimension mm A_s	inch	Mass kg		
10	$45/64$	$2\ 5/8$	$5/8$	$2\ 3/32$	$9/32$	$1/4$	$1\ 3/8$	$23/32$	0.591	0.197	$1/4$	UP000	P000	SU000		4.55	1.95	12.3	UP000C	UP000CD	29	$1\ 5/32$	0.07
	18	67	16	53	7	6	35	18	15	5	M6												
12	$3/4$	$2\ 25/32$	$5/8$	$2\ 13/64$	$9/32$	$1/4$	$1\ 1/2$	$3/4$	0.591	0.197	$1/4$	UP001	P001	SU001		5.10	2.40	13.2	UP001C	UP001CD	29	$1\ 5/32$	0.09
	19	71	16	56	7	6	38	19	15	5	M6												
15	$55/64$	$3\ 5/32$	$5/8$	$2\ 31/64$	$9/32$	$9/32$	$1\ 11/16$	$13/16$	0.650	0.217	$1/4$	UP002	P002	SU002		5.60	2.85	13.9	UP002C	UP002CD	31	$1\ 7/32$	0.11
	22	80	16	63	7	7	43	21	16.5	5.5	M6												
17	$15/16$	$3\ 11/32$	$23/32$	$2\ 41/64$	$9/32$	$9/32$	$1\ 27/32$	$13/16$	0.689	0.236	$1/4$	UP003	P003	SU003		6.00	3.25	14.4	UP003C	UP003CD	33	$1\ 5/16$	0.15
	24	85	18	67	7	7	47	21	17.5	6	M6												
20	$1\ 7/64$	$3\ 15/16$	$25/32$	$3\ 5/32$	$13/32$	$11/32$	$2\ 5/32$	$31/32$	0.827	0.276	$5/16$	UP004	P004	SU004		9.40	5.05	13.9	UP004C	UP004CD	38	$1\ 1/2$	0.23
	28	100	20	80	10	9	55	25	21	7	M8												
25	$1\ 17/64$	$4\ 13/32$	$25/32$	$3\ 35/64$	$13/32$	$13/32$	$2\ 7/16$	$1\ 3/32$	0.866	0.276	$5/16$	UP005	P005	SU005		10.1	5.85	14.5	UP005C	UP005CD	40	$1\ 9/16$	0.28
	32	112	20	90	10	10	62	28	22	7	M8												
30	$1\ 27/64$	$5\ 3/16$	$1\ 1/32$	$4\ 11/64$	$1/2$	$7/16$	$2\ 3/4$	$1\ 11/32$	0.965	0.295	$3/8$	UP006	P006	SU006		13.2	8.25	14.7	UP006C	UP006CD	44	$1\ 23/32$	0.42
	36	132	26	106	13	11	70	34	24.5	7.5	M10												

Remarks 1. In Part No. of unit and units with covers, fitting codes follow bore diameter codes. (See Table 10.5 in P.62.)
2. For the dimensions and forms of applicable bearings, see the dimensional tables of ball bearing for unit.

UCSPA-H1S6
Cylindrical bore (with set screws)
d 12 ~ 40 mm

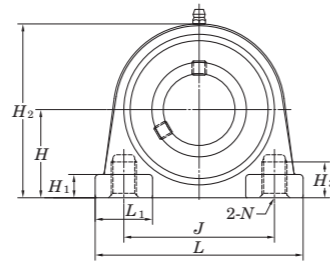
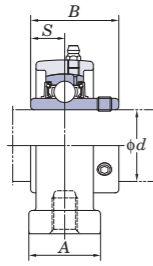
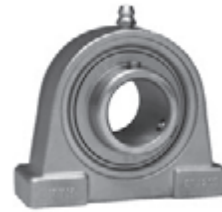

With Pressed Stainless Steel Cover

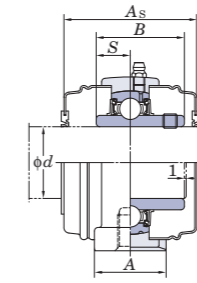

Variations of tolerance of distance from mounting bottom to center of spherical bore (ΔH_s) and variations of tolerance of distance between centers of bolt holes (ΔL_s)

Housing No.	ΔH_s	ΔL_s
SPA203H1~SPA208H1	± 0.15	± 0.5

Unit: mm

Shaft Dia. mm inch <i>d</i>	Dimensions inch mm											Standard			Mass kg	Basic Load Ratings kN		Factor <i>f</i> ₀	With Pressed Stainless Steel Cover			
	<i>H</i>	<i>L</i>	<i>A</i>	<i>J</i>	<i>N</i>	<i>H</i> ₁	<i>H</i> ₂	<i>H</i> ₃	<i>L</i> ₁	<i>B</i>	<i>S</i>	Unit No.	Housing No.	Bearing No.		<i>C</i> _r	<i>C</i> _{0r}		Open Type	One Side Closed Type	Dimension mm inch <i>A</i> _s	Mass kg
12 15 17	1/2 5/8	1 3/16	3	1 3/16	2 3/64	13/32	2 1/4	33/64	7/8	1.079	0.453	UCSPA201XH1S6	SPA203H1	UC201XS6	8.15	3.85	13.2	-	-	-	-	
		30.2	76	30	52	M10×1.5	10	57	13	22	27.4	11.5		UCSPA201-8XH1S6				UC201-8XS6	-	-	-	-
														UCSPA202XH1S6				UC202XS6	-	-	-	-
														UCSPA202-10XH1S6				UC202-10XS6	-	-	-	-
20	3/4	1 3/16	3	1 3/16	2 3/64	13/32	2 3/8	33/64	7/8	1.220	0.500	UCSPA203XH1S6	SPA204H1	UC203XS6	10.9	5.35	13.2	-	-	-	-	
		30.2	76	30	52	M10×1.5	10	60	13	22	31	12.7		UCSPA204-12H1S6				UC204-12S6	-	-	-	-
														UCSPA204H1S6				UC204S6	-	-	-	-
														UCSPA204H1CS6				UCSPA204H1CDS6	45	1 25/32	0.46	-
25	7/8 15/16	1 7/16	3 5/16	1 3/16	2 13/64	15/32	2 23/32	33/64	15/16	1.343	0.563	UCSPA205-14H1S6	SPA205H1	UC205-14S6	11.9	6.3	13.9	-	-	-	-	
		36.5	84	30	56	M10×1.5	12	69	13	24	34.1	14.3		UCSPA205-15H1S6				UC205-15S6	-	-	-	-
														UCSPA205H1S6				UC205S6	-	-	-	-
														UCSPA205-16H1S6				UC205-16S6	-	-	-	-
30	1 1/8 1 3/16 1 1/4	1 11/16	3 11/16	1 13/32	2 19/32	15/32	3 3/16	45/64	1 3/32	1.500	0.626	UCSPA206-18H1S6	SPA206H1	UC206-18S6	16.5	9.05	13.9	-	-	-	-	
		42.9	94	36	66	M14×2	12	81	18	28	38.1	15.9		UCSPA206H1S6				UC206S6	-	-	-	-
														UCSPA206-19H1S6				UC206-19S6	-	-	-	-
														UCSPA206-20H1S6				UC206-20S6	-	-	-	-
35	1 1/4 1 5/16 1 3/8	1 7/8	4 11/32	1 1/2	3 5/32	1/2	3 19/32	25/32	1 3/16	1.689	0.689	UCSPA207-20H1S6	SPA207H1	UC207-20S6	21.8	12.3	13.9	-	-	-	-	
		47.6	110	38	80	M14×2	13	91	20	30	42.9	17.5		UCSPA207-21H1S6				UC207-21S6	-	-	-	-
														UCSPA207-22H1S6				UC207-22S6	-	-	-	-
														UCSPA207H1S6				UC207S6	-	-	-	-
40	1 7/16 1 1/2 1 9/16	1 15/16	4 9/16	1 9/16	3 5/16	1/2	3 13/16	25/32	1 1/4	1.937	0.748	UCSPA207-23H1S6	SPA208H1	UC207-23S6	24.8	14.3	14.0	-	-	-	-	
		49.2	116	40	84	M14×2	13	97	20	32	49.2	19		UCSPA208-24H1S6				UC208-24S6	-	-	-	-
														UCSPA208-25H1S6				UC208-25S6	-	-	-	-
														UCSPA208H1S6				UC208S6	-	-	-	-
											UCSPA208H1CS6	UCSPA208H1CDS6	69	2 23/32	1.5	-	-	-				

Remarks 1. In Part No. of unit and units with covers, fitting codes follow bore diameter codes. (See Table 10.5 in P.62.)
2. Part No. of the applicable grease fitting is A-1/4-28UNFN12.
3. For the dimensions and forms of applicable bearings, see the dimensional tables of ball bearing for unit.

USP-S6
Cylindrical bore (with set screws)
 d 10 ~ 30 mm

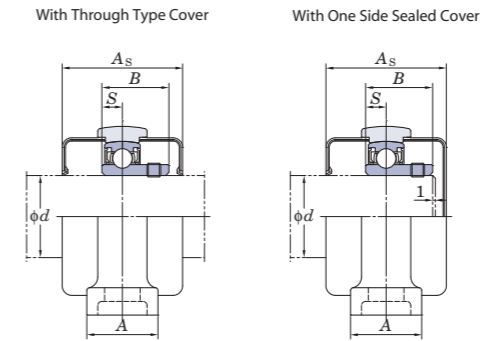
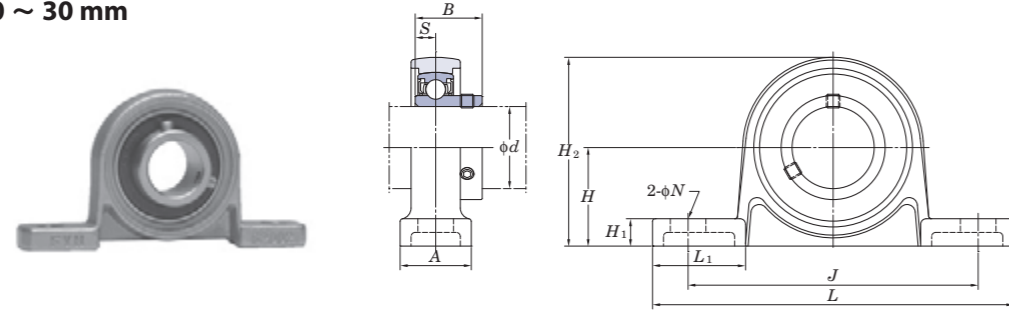

Variations of tolerance of distance from mounting bottom to center of spherical bore (ΔH_s) and variations of tolerance of distance between centers of bolt holes (ΔL_s)

Housing No.	ΔH_s	ΔL_s
SP000~SP006	±0.15	±0.3

Unit: mm

Shaft Dia. mm d	Dimensions inch mm										Bolt Size inch mm	Standard			Mass kg	Basic Load Ratings kN		Factor f_0	With Rubber Coated Cover				
	H	L	A	J	N	H_1	H_2	L_1	B	S		Unit No.	Housing No.	Bearing No.		Open Type	One Side Closed Type		Dimension mm A_s	inch	Mass kg		
10	45/64	2 5/8	5/8	2 3/32	9/32	3/16	1 3/8	23/32	0.591	0.197	1/4	USP000S6	SP000	SU000S6	0.076	3.9	1.55	12.3	USP000CS6	USP000CDS6	29	1 5/32	0.08
	18	67	16	53	7	5	35	18	15	5	M6												
12	3/4	2 25/32	5/8	2 7/32	9/32	3/16	1 15/32	23/32	0.591	0.197	1/4	USP001S6	SP001	SU001S6	0.08	4.3	1.9	13.2	USP001CS6	USP001CDS6	29	1 5/32	0.08
	19	71	16	56	7	5	37	18.5	15	5	M6												
15	55/64	3 5/32	5/8	2 15/32	9/32	1/4	1 11/16	13/16	0.650	0.217	1/4	USP002S6	SP002	SU002S6	0.11	4.7	2.25	13.9	USP002CS6	USP002CDS6	31	1 7/32	0.11
	22	80	16	63	7	6	42.5	20.5	16.5	5.5	M6												
17	15/16	3 11/32	23/32	2 5/8	9/32	1/4	1 13/16	13/16	0.689	0.236	1/4	USP003S6	SP003	SU003S6	0.14	5.1	2.6	14.4	USP003CS6	USP003CDS6	33	1 5/16	0.14
	24	85	18	67	7	6	46	21	17.5	6	M6												
20	1 7/64	3 15/16	25/32	3 5/32	13/32	5/16	2 5/32	31/32	0.827	0.276	5/16	USP004S6	SP004	SU004S6	0.23	7.9	4	13.9	USP004CS6	USP004CDS6	38	1 1/2	0.23
	28	100	20	80	10	8	54.5	25	21	7	M8												
25	1 17/64	4 13/32	25/32	3 17/32	13/32	11/32	2 13/32	1 3/32	0.866	0.276	5/16	USP005S6	SP005	SU005S6	0.28	8.5	4.65	14.5	USP005CS6	USP005CDS6	40	1 9/16	0.28
	32	112	20	90	10	9	61	27.5	22	7	M8												
30	1 27/64	5 3/16	1 1/32	4 3/16	1/2	13/32	2 23/32	1 11/32	0.965	0.295	3/8	USP006S6	SP006	SU006S6	0.43	11.2	6.6	14.7	USP006CS6	USP006CDS6	44	1 23/32	0.43
	36	132	26	106	13	10	69	34	24.5	7.5	M10												

Remarks 1. In Part No. of unit and units with covers, fitting codes follow bore diameter codes. (See Table 10.5 in P.62.)
2. For the dimensions and forms of applicable bearings, see the dimensional tables of ball bearing for unit.

UCVP-S6
Cylindrical bore (with set screws)
 d 20 ~ 50 mm

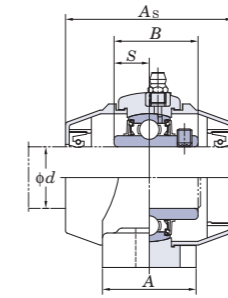
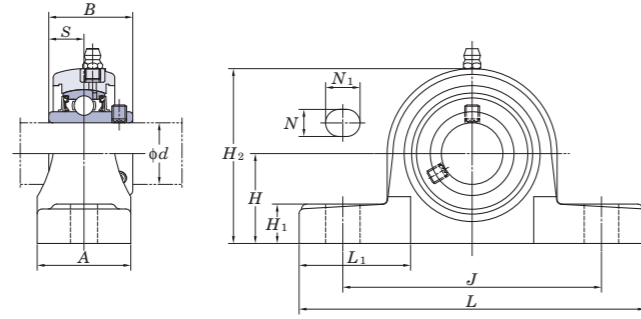

Variations of tolerance of distance from mounting bottom to center of spherical bore (ΔH_s)

Housing No.	Unit: mm ΔH_s
VP204~VP208	± 0.15
VP209~VP210	± 0.2

Shaft Dia. mm inch d	Dimensions inch mm											Bolt Size inch mm	Standard			Mass kg	Basic Load Ratings kN		Factor f_0	With Plastic Cover			
	H	L	A	J	N	N_1	H_1	H_2	B	S	Unit No.		Housing No.	Bearing No.	Open Type		One Side Closed Type	Dimension mm inch A_s		Mass kg			
20 $3/4$	$1\ 5/16$	5	$1\ 1/2$	$3\ 3/4$	$7/16$	$9/16$	$9/16$	$2\ 19/32$	1.220	0.500	$3/8$	UCVP204-12S6 UCVP204S6	VP204	UC204-12S6 UC204S6		10.9	5.35	13.2	UCVP204-12CS6 UCVP204CS6	UCVP204-12CDS6 UCVP204CDS6	63	$2\ 15/32$	0.31
	33.3	127	38	95	11	14	14.2	65.5	31	12.7	M10												
25 $7/8$ $15/16$	$1\ 7/16$	$5\ 17/32$	$1\ 1/2$	$4\ 1/8$	$7/16$	$9/16$	$5/8$	$2\ 25/32$	1.343	0.563	$3/8$	UCVP205-14S6 UCVP205-15S6 UCVP205S6 UCVP205-16S6	VP205	UC205-14S6 UC205-15S6 UC205S6 UC205-16S6		11.9	6.3	13.9	UCVP205-14CS6 UCVP205-15CS6 UCVP205CS6 UCVP205-16CS6	UCVP205-14CDS6 UCVP205-15CDS6 UCVP205CDS6 UCVP205-16CDS6	68	$2\ 11/16$	0.43
	36.5	140.5	38	105	11	14	16	71	34.1	14.3	M10												
30 $1\ 1/8$ $1\ 3/16$ $1\ 1/4$	$1\ 11/16$	$6\ 13/32$	$1\ 13/16$	$4\ 11/16$	$9/16$	$23/32$	$11/16$	$3\ 5/16$	1.500	0.626	$1/2$	UCVP206-18S6 UCVP206S6 UCVP206-19S6 UCVP206-20S6	VP206	UC206-18S6 UC206S6 UC206-19S6 UC206-20S6		16.5	9.05	13.9	UCVP206-18CS6 UCVP206CS6 UCVP206-19CS6 UCVP206-20CS6	UCVP206-18CDS6 UCVP206CDS6 UCVP206-19CDS6 UCVP206-20CDS6	79	$3\ 1/8$	0.63
	42.9	163	46	119	14	18	17.8	84	38.1	15.9	M12												
35 $1\ 1/4$ $1\ 5/16$ $1\ 3/8$ $1\ 7/16$	$1\ 7/8$	$6\ 5/8$	$1\ 7/8$	5	$9/16$	$23/32$	$23/32$	$3\ 23/32$	1.689	0.689	$1/2$	UCVP207-20S6 UCVP207-21S6 UCVP207-22S6 UCVP207S6 UCVP207-23S6	VP207	UC207-20S6 UC207-21S6 UC207-22S6 UC207S6 UC207-23S6		21.8	12.3	13.9	UCVP207-20CS6 UCVP207-21CS6 UCVP207-22CS6 UCVP207CS6 UCVP207-23CS6	UCVP207-20CDS6 UCVP207-21CDS6 UCVP207-22CDS6 UCVP207CDS6 UCVP207-23CDS6	85	$3\ 11/32$	0.89
	47.6	168	48	127	14	18	18	94.5	42.9	17.5	M12												
40 $1\ 1/2$ $1\ 9/16$	$1\ 15/16$	$7\ 1/4$	$2\ 1/8$	$5\ 13/32$	$9/16$	$23/32$	$25/32$	$3\ 31/32$	1.937	0.748	$1/2$	UCVP208-24S6 UCVP208-25S6 UCVP208S6	VP208	UC208-24S6 UC208-25S6 UC208S6		24.8	14.3	14.0	UCVP208-24CS6 UCVP208-25CS6 UCVP208CS6	UCVP208-24CDS6 UCVP208-25CDS6 UCVP208CDS6	96	$3\ 25/32$	1.16
	49.2	184	54	137	14	18	19.5	101	49.2	19	M12												
45 $1\ 5/8$ $1\ 11/16$ $1\ 3/4$	$2\ 1/8$	$7\ 9/16$	$2\ 1/8$	$5\ 3/4$	$21/32$	$25/32$	$29/32$	$4\ 3/16$	1.937	0.748	$5/8$	UCVP209-26S6 UCVP209-27S6 UCVP209-28S6 UCVP209S6	VP209	UC209-26S6 UC209-27S6 UC209-28S6 UC209S6		27.8	16.2	14.0	UCVP209-26CS6 UCVP209-27CS6 UCVP209-28CS6 UCVP209CS6	UCVP209-26CDS6 UCVP209-27CDS6 UCVP209-28CDS6 UCVP209CDS6	107	$4\ 7/32$	1.26
	54	192	54	146	17	20	23	106	49.2	19	M14												
50 $1\ 7/8$ $1\ 15/16$ 2	$2\ 1/4$	$8\ 1/8$	$2\ 3/8$	$6\ 1/4$	$21/32$	$25/32$	$29/32$	$4\ 1/2$	2.031	0.748	$5/8$	UCVP210-30S6 UCVP210-31S6 UCVP210S6 UCVP210-32S6	VP210	UC210-30S6 UC210-31S6 UC210S6 UC210-32S6		29.8	18.6	14.4	UCVP210-30CS6 UCVP210-31CS6 UCVP210CS6 UCVP210-32CS6	UCVP210-30CDS6 UCVP210-31CDS6 UCVP210CDS6 UCVP210-32CDS6	120	$4\ 23/32$	1.46
	57.2	206	60	159	17	20	23	114	51.6	19	M14												

Remarks 1. In Part No. of unit and units with covers, fitting codes follow bore diameter numbers. (See Table 10.5 in P.62.)
2. Part No. of the applicable grease fitting is A-1/4-28UNFN12.
3. For the dimensions and forms of applicable bearings, see the dimensional tables of ball bearing for unit.

UCVP-ES7
Cylindrical bore (with set screws)
d 20 ~ 50 mm

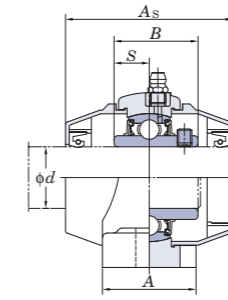
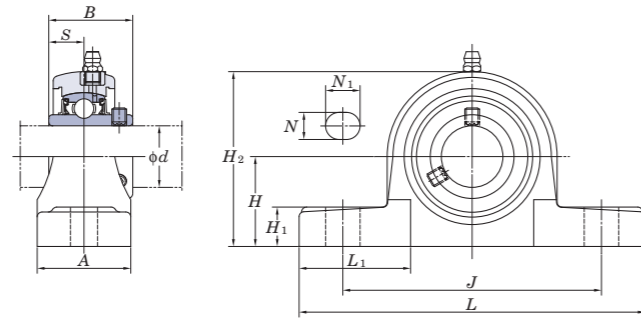

Variations of tolerance of distance from mounting bottom to center of spherical bore (ΔH_s)

Housing No.	Unit: mm ΔH_s
VP204E~VP208E	± 0.15
VP209E~VP210E	± 0.2

Shaft Dia. mm inch d	Dimensions inch mm											Bolt Size inch mm	Standard			Mass kg	Basic Load Ratings kN		Factor f ₀	With Plastic Cover			
	H	L	A	J	N	N ₁	H ₁	H ₂	B	S	Unit No.		Housing No.	Bearing No.	Open Type		One Side Closed Type	Dimension mm inch A _s		Mass kg			
20 3/4	1 5/16	5	1 1/2	3 3/4	7/16	9/16	9/16	2 19/32	1.220	0.500	3/8	UCVP204-12ES7 UCVP204ES7	VP204E	UC204-12S7 UC204S7	0.29	12.8	6.65	13.2	UCVP204-12ECS7	UCVP204-12ECDS7	63	2 15/32	0.31
	33.3	127	38	95	11	14	14.2	65.5	31	12.7	M10								UC205-14S7				
25 7/8 15/16	1 7/16	5 17/32	1 1/2	4 1/8	7/16	9/16	5/8	2 25/32	1.343	0.563	3/8	UCVP205-14ES7 UCVP205-15ES7 UCVP205ES7 UCVP205-16ES7	VP205E	UC205-14S7 UC205-15S7 UC205S7 UC205-16S7	0.41	14.0	7.85	13.9	UCVP205-14ECS7	UCVP205-14ECDS7	68	2 11/16	0.43
	36.5	140.5	38	105	11	14	16	71	34.1	14.3	M10								UC206-18S7				
30 1 1 1/8	1 11/16	6 13/32	1 13/16	4 11/16	9/16	23/32	11/16	3 5/16	1.500	0.626	1/2	UCVP206-18ES7 UCVP206ES7 UCVP206-19ES7 UCVP206-20ES7	VP206E	UC206-18S7 UC206S7 UC206-19S7 UC206-20S7	0.6	19.5	11.3	13.9	UCVP206-18ECS7	UCVP206-18ECDS7	79	3 1/8	0.63
	42.9	163	46	119	14	18	17.8	84	38.1	15.9	M12								UC207-20S7				
35 1 1/4 1 5/16 1 3/8	1 7/8	6 5/8	1 7/8	5	9/16	23/32	23/32	3 23/32	1.689	0.689	1/2	UCVP207-20ES7 UCVP207-21ES7 UCVP207-22ES7 UCVP207ES7 UCVP207-23ES7	VP207E	UC207-20S7 UC207-21S7 UC207-22S7 UC207S7 UC207-23S7	0.84	25.7	15.4	13.9	UCVP207-20ECS7	UCVP207-20ECDS7	85	3 11/32	0.89
	47.6	168	48	127	14	18	18	94.5	42.9	17.5	M12								UC208-24S7				
40 1 1/2 1 9/16	1 15/16	7 1/4	2 1/8	5 13/32	9/16	23/32	25/32	3 31/32	1.937	0.748	1/2	UCVP208-24ES7 UCVP208-25ES7 UCVP208ES7	VP208E	UC208-24S7 UC208-25S7 UC208S7	1.1	29.1	17.8	14.0	UCVP208-24ECS7	UCVP208-24ECDS7	96	3 25/32	1.16
	49.2	184	54	137	14	18	19.5	101	49.2	19	M12								UC209-26S7				
45 1 5/8 1 11/16 1 3/4	2 1/8	7 9/16	2 1/8	5 3/4	21/32	25/32	29/32	4 3/16	1.937	0.748	5/8	UCVP209-26ES7 UCVP209-27ES7 UCVP209-28ES7 UCVP209ES7	VP209E	UC209-26S7 UC209-27S7 UC209-28S7 UC209S7	1.2	34.1	21.3	14.0	UCVP209-26ECS7	UCVP209-26ECDS7	107	4 7/32	1.26
	54	192	54	146	17	20	23	106	49.2	19	M14								UC210-30S7				
50 1 7/8 1 15/16 2	2 1/4	8 1/8	2 3/8	6 1/4	21/32	25/32	29/32	4 1/2	2.031	0.748	5/8	UCVP210-30ES7 UCVP210-31ES7 UCVP210ES7 UCVP210-32ES7	VP210E	UC210-30S7 UC210-31S7 UC210S7 UC210-32S7	1.4	35.1	23.3	14.4	UCVP210-30ECS7	UCVP210-30ECDS7	120	4 23/32	1.46
	57.2	206	60	159	17	20	23	114	51.6	19	M14								UC210-31S7				

Remarks 1. In Part No. of unit and units with covers, fitting codes follow bore diameter numbers. (See Table 10.5 in P.62.)
2. Part No. of the applicable grease fitting is A-1/4-28UNFN12.
3. For the dimensions and forms of applicable bearings, see the dimensional tables of ball bearing for unit.

UCVPAN-ES7
Cylindrical bore (with set screws)
 d 20 ~ 35 mm

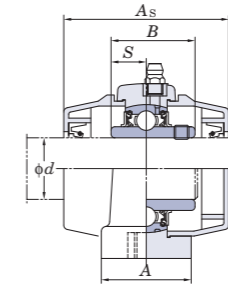
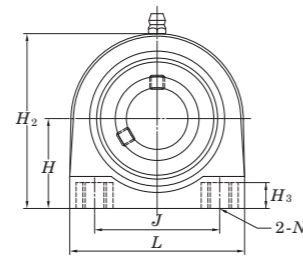
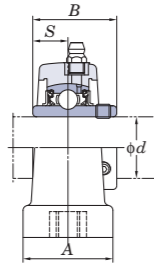

Shaft Dia. mm inch d	Dimensions										Unit No.	Standard Housing No.	Bearing No.	Mass kg	Basic Load Ratings kN		Factor f_0	With Plastic Cover		Dimension mm inch A_s	Mass kg
	H	L	A	J	N	H_2	H_3	B	S	Open Type					One Side Closed Type						
20 $\frac{3}{4}$	$1\frac{5}{16}$	$2\frac{7}{8}$	$1\frac{11}{32}$	2	$\frac{3}{8}$ -16UNC	$2\frac{19}{32}$	$\frac{13}{32}$	1.220	0.500	UCVPAN204-12ES7 UCVPAN204ES7	VPAN204E	UC204-12S7 UC204S7	0.26	12.8	6.65	13.2	UCVPAN204-12ECS7 UCVPAN204ECS7	UCVPAN204-12ECDS7 UCVPAN204ECDS7	59.5	$2\frac{11}{32}$	0.27
	33.3	73	34.5	50.8		66	10.5	31	12.7												
25 $\frac{7}{8}$ $\frac{15}{16}$	$1\frac{7}{16}$	$2\frac{25}{32}$	$1\frac{7}{16}$	2	$\frac{3}{8}$ -16UNC	$2\frac{25}{32}$	$\frac{13}{32}$	1.343	0.563	UCVPAN205-14ES7 UCVPAN205-15ES7 UCVPAN205ES7	VPAN205E	UC205-14S7 UC205-15S7 UC205S7	0.36	14.0	7.85	13.9	UCVPAN205-14ECS7 UCVPAN205ECS7	UCVPAN205-14ECDS7 UCVPAN205ECDS7	66.5	$2\frac{5}{8}$	0.37
	$1\frac{7}{16}$	71	36.5	50.8		71	10.5	34.1	14.3												
30 1 $1\frac{1}{8}$ $1\frac{3}{16}$ $1\frac{1}{4}$	$1\frac{11}{16}$	4	$1\frac{11}{16}$	3	$\frac{7}{16}$ -14UNC	$3\frac{5}{16}$	$\frac{15}{32}$	1.500	0.626	UCVPAN206-18ES7 UCVPAN206ES7 UCVPAN206-19ES7 UCVPAN206-20ES7	VPAN206E	UC206-18S7 UC206S7 UC206-19S7 UC206-20S7	0.54	19.5	11.3	13.9	UCVPAN206-18ECS7 UCVPAN206ECS7	UCVPAN206-18ECDS7 UCVPAN206CDS7	75.5	$2\frac{31}{32}$	0.55
	42.9	101.6	42.5	76.2		84	12.1	38.1	15.9												
35 $1\frac{1}{4}$ $1\frac{5}{16}$ $1\frac{3}{8}$ $1\frac{7}{16}$	$1\frac{7}{8}$	$4\frac{11}{32}$	$1\frac{7}{8}$	$3\frac{1}{4}$	$\frac{1}{2}$ -13UNC	$3\frac{3}{4}$	$\frac{17}{32}$	1.689	0.689	UCVPAN207-20ES7 UCVPAN207-21ES7 UCVPAN207-22ES7 UCVPAN207ES7 UCVPAN207-23ES7	VPAN207E	UC207-20S7 UC207-21S7 UC207-22S7 UC207S7 UC207-23S7	0.84	25.7	15.4	13.9	UCVPAN207-20ECS7 UCVPAN207-21ECS7	UCVPAN207-20ECDS7 UCVPAN207-21ECDS7	85	$3\frac{11}{32}$	0.86
	47.6	110	48	82.6		95	13.7	42.9	17.5												

Remarks 1. In Part No. of unit and units with covers, fitting codes follow bore diameter numbers. (See Table 10.5 in P.62.)
2. Part No. of the applicable grease fitting is A-1/4-28UNFN12.
3. For the dimensions and forms of applicable bearings, see the dimensional tables of ball bearing for unit.

SBPP
Cylindrical bore
(with set screws)
 d 12 ~ 30 mm

SAPP
Cylindrical bore
(with eccentric locking collar)



SBPP

SAPP

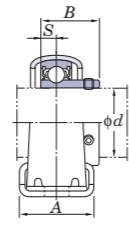

SBPP

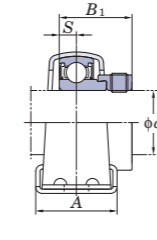
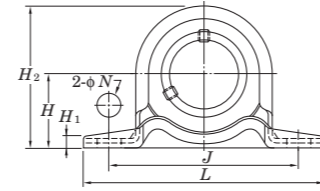

SAPP

Variations of tolerance of distance between centers of bolt holes (ΔJ_s) and variations of tolerance of bolt hole diameter (ΔN_s)

Housing No.	ΔJ_s	ΔN_s
PP203~PP206	± 0.4	± 0.5

Unit: mm

Shaft Dia mm	inch	Dimensions										Bolt Size inch mm	Unit No.	Bearing No.	Unit No.	Bearing No.	Housing No.	Basic Load Ratings kN		Factor f_0	Mass kg	
		H	L	A	J	N	H_1	H_2	S	SBPP B	SAPP B_1							C_r	C_{0r}		SBPP	SAPP
12	1/2	7/8	3 3/8	31/32	2 43/64	3/8	1/8	1 23/32	0.236	0.866	1.122	5/16	SBPP201	SB201	SAPP201	SA201	PP203	9.55	4.80	13.2	0.16	0.19
		22.2	86	25	68	9.5	3.2	43.8	6	22	28.5	M8	SBPP201-8	SB201-8								
15	5/8	1	3 27/32	1 1/4	2 63/64	3/8	1/8	2	0.276	0.984	1.161	5/16	SBPP204-12	SB204-12	SAPP204-12	SA204-12	PP204	12.8	6.65	13.2	0.23	0.23
		25.4	98	32	76	9.5	3.2	50.5	7	25	29.5	M8	SBPP204	SB204								
17	7/8	1 1/8	4 1/4	1 1/4	3 25/64	29/64	5/32	2 7/32	0.295	1.063	1.201	3/8	SBPP205-14	SB205-14	SAPP205-14	SA205-14	PP205	14.0	7.85	13.9	0.28	0.32
		28.6	108	32	86	11.5	4	56.6	7.5	27	30.5	M10	SBPP205-15	SB205-15								
20	1 1/8	1 5/16	4 19/32	1 1/2	3 3/4	29/64	5/32	2 5/8	0.315	1.181	1.335	3/8	SBPP206-18	SB206-18	SAPP206-18	SA206-18	PP206	19.5	11.3	13.9	0.47	0.50
		33.3	117	38	95	11.5	4	66.3	8	30	33.9	M10	SBPP206	SB206								

Remark For the dimensions and forms of applicable bearings, see the dimensional tables of ball bearing for unit.

UCF-E
Cylindrical bore (with set screws)
 d 12 ~ 50 mm

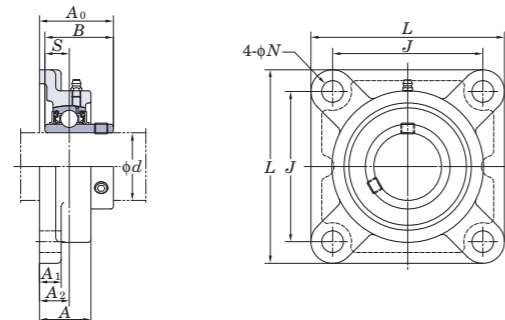

Variations of tolerance of distance from mounting surface to center of spherical bore (ΔA_{2s}) and tolerance of position of bolt hole (X)

Housing No.		Unit: mm	
		ΔA_{2s}	X
F204E~F210E	FX05E~FX10E	± 0.5	0.7
F211E~F217E	FX11E~FX17E	± 0.8	1

Variations of tolerance of bolt hole diameter (ΔN_s)

Housing No.		Unit: mm	
		ΔN_s	
F204E~F217E	FX05E~FX17E	± 0.2	

Shaft Dia. mm inch	Dimensions inch mm	Bolt Size inch	Unit No.	Housing No.	Bearing No.	Basic Load Ratings kN	Factor	Mass				
									L	A	J	N
12			UCF201E		UC201			0.64				
15			UCF201-8E		UC201-8			0.62				
17			UCF202E		UC202			0.61				
20			UCF202-10E	F204E	UC202-10	12.8	6.65	13.2				
			UCF203E		UC203			0.59				
			UCF204-12E		UC204-12							
			UCF204E		UC204							
25			UCF205-14E		UC205-14			0.83				
			UCF205-15E	F205E	UC205-15	14.0	7.85	13.9				
			UCF205E		UC205							
			UCF205-16E		UC205-16							
			UCFX05E	FX05E	UCX05	19.5	11.3	13.9				
			UCFX05-16E		UCX05-16			1.2				
30			UCF206-18E		UC206-18			1.1				
			UCF206E	F206E	UC206	19.5	11.3	13.9				
			UCF206-19E		UC206-19							
			UCF206-20E		UC206-20							
			UCFX06E	FX06E	UCX06	25.7	15.4	13.9				
			UCFX06-19E		UCX06-19			1.6				
			UCFX06-20E		UCX06-20							
35			UCF207-20E		UC207-20			1.5				
			UCF207-21E	F207E	UC207-21	25.7	15.4	13.9				
			UCF207-22E		UC207-22							
			UCF207E		UC207							
			UCF207-23E		UC207-23							
			UCFX07-22E	FX07E	UCX07-22	29.1	17.8	14.0				
			UCFX07E		UCX07			2.0				
			UCFX07-23E		UCX07-23							
40			UCF208-24E		UC208-24			1.9				
			UCF208-25E	F208E	UC208-25	29.1	17.8	14.0				
			UCF208E		UC208							
			UCFX08-24E	FX08E	UCX08-24	34.1	21.3	14.0				
			UCFX08E		UCX08			2.4				
45			UCF209-26E		UC209-26			2.2				
			UCF209-27E	F209E	UC209-27	34.1	21.3	14.0				
			UCF209-28E		UC209-28							
			UCF209E		UC209							
			UCFX09-27E	FX09E	UCX09-27	35.1	23.3	14.4				
			UCFX09-28E		UCX09-28			2.7				
			UCFX09E		UCX09							
50			UCF210-30E		UC210-30			2.5				
			UCF210-31E	F210E	UC210-31	35.1	23.3	14.4				
			UCF210E		UC210							
			UCF210-32E		UC210-32							
			UCFX10-31E	FX10E	UCX10-31	43.4	29.4	14.4				
			UCFX10E		UCX10			3.7				
			UCFX10-32E		UCX10-32							

Remarks 1. In Part No. of unit, fitting codes follow bore diameter numbers. (See Table 10.5 in P.62.)
2. Part No. of applicable grease fittings are shown below.
A-1/4-28UNF 201~210, X05~X09
A-R1/8 211~217, X10~X17

3. As for the triple seal type product (from 201 to 205 are the double seal type products), suffix code L3 (L2) follows the Part No. of unit or bearing. (Example of Part No.: UCF206EJL3, UC206L3)
4. For the dimensions and forms of applicable bearings, see the dimensional tables of ball bearing for unit.
5. Housings of nodular graphite cast iron are also available.

UCF-E
Cylindrical bore (with set screws)
d 55 ~ 85 mm

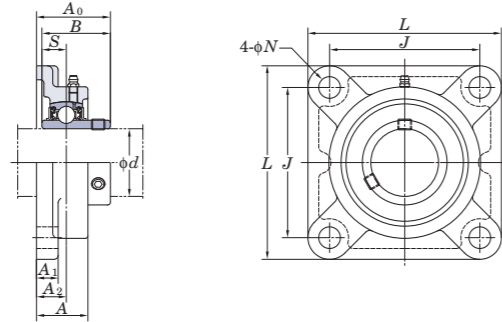

Shaft Dia. mm inch	d	Dimensions inch mm									Bolt Size inch	Unit No.	Housing No.	Bearing No.	Basic Load Ratings kN		Factor f ₀	Mass kg
		L	A	J	N	A ₁	A ₂	A ₀	B	S					C _r	C _{0r}		
55	2	6 3/8	1 11/16	5 1/8	43/64	23/32	63/64	2 5/16	2.189	0.874	5/8	UCF211-32E	F211E	UC211-32	43.4	29.4	14.4	3.4
	2 1/8											UCF211-34E		UC211-34				
	2 3/16	UCF211E	UC211															
	2 3/16	UCF211-35E	UC211-35															
60	2 3/16	6 7/8	1 15/16	5 5/8	21/32	25/32	1 9/64	2 23/32	2.563	1.000	9/16	UCFX11E	FX11E	UCX11	52.4	36.2	14.4	4.9
	2 1/4											UCFX11-35E		UCX11-35				
	2 1/4	UCFX11-36E	UCX11-36															
	2 3/8	UCF212-36E	UC212-36															
65	2 3/8	6 7/8	1 7/8	5 5/8	43/64	23/32	1 9/64	2 23/32	2.563	1.000	5/8	UCF212E	F212E	UC212	52.4	36.2	14.4	4.2
	2 7/16											UCF212-38E		UC212-38				
	2 7/16	UCF212-39E	UC212-39															
	2 7/16	UCFX12E	UCX12															
70	2 7/16	7 3/8	2 5/16	5 55/64	21/32	13/16	1 11/32	2 29/32	2.563	1.000	9/16	UCFX12-39E	FX12E	UCX12-39	57.2	40.1	14.4	5.7
	2 1/2											UCF213-40E		UC213-40				
	2 1/2	UCF213E	UC213															
	2 1/2	UCFX13-40E	UCX13-40															
75	2 1/2	7 3/8	1 31/32	5 55/64	21/32	13/16	1 11/32	3 3/32	2.937	1.189	5/8	UCF214-44E	F214E	UC214-44	62.2	44.1	14.5	6.3
	2 3/4											UCF214E		UC214				
	2 3/4	UCFX14-44E	UCX14-44															
	2 3/4	UCFX14E	UCX14															
80	2 3/4	7 7/8	2 7/32	6 17/64	3/4	7/8	1 11/32	3 3/32	3.063	1.311	5/8	UCF215-47E	F215E	UC215-47	67.4	48.3	14.5	6.4
	3											UCF215E		UC215				
	3	UCF215-48E	UC215-48															
	3	UCFX15-47E	UCX15-47															
85	3	7 3/4	2 11/16	5 63/64	25/32	15/16	1 9/16	3 17/32	3.252	1.311	11/16	UCFX15E	FX15E	UCX15	72.7	53.0	14.6	8.4
	3 1/8											UCF216-50E		UC216-50				
	3 1/8	UCF216E	UC216															
	3 1/8	UCFX16E	UCX16															
85	3 1/8	8 3/16	2 9/32	6 1/2	3/4	7/8	1 11/32	3 9/32	3.252	1.311	11/16	UCF217-52E	F217E	UC217-52	84.0	61.9	14.5	8.9
	3 1/4											UCF217E		UC217				
	3 1/4	UCFX17E	UCX17															
	3 7/16	UCFX17-55E	UCX17-55															

Variations of tolerance of distance from mounting surface to center of spherical bore (ΔA_{2s}) and tolerance of position of bolt hole (X)

Housing No.	ΔA_{2s}	X	Unit: mm
F204E~F210E	FX05E~FX10E	±0.5	0.7
F211E~F217E	FX11E~FX17E	±0.8	1

Variations of tolerance of bolt hole diameter (ΔN_s)

Housing No.	ΔN_s	Unit: mm
F204E~F217E	FX05E~FX17E	±0.2

Remarks 1. In Part No. of unit, fitting codes follow bore diameter numbers. (See Table 10.5 in P.62.)
2. Part No. of applicable grease fittings are shown below.
A-1/4-28UNF 201~210, X05~X09
A-R1/8 211~217, X10~X17

3. As for the triple seal type product (from 201 to 205 are the double seal type products), suffix code L3 (L2) follows the Part No. of unit or bearing. (Example of Part No.: UCF206JL3, UC206L3)
4. For the dimensions and forms of applicable bearings, see the dimensional tables of ball bearing for unit.
5. Housings of nodular graphite cast iron are also available.

NANF
Cylindrical bore
 (with eccentric locking collar)
d 12 ~ 60 mm

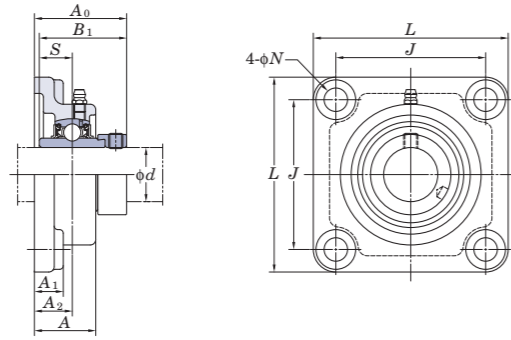

Variations of tolerance of distance from mounting surface to center of spherical bore (ΔA_{2s}) and tolerance of position of bolt hole (\bar{X})

Housing No.	ΔA_{2s}	\bar{X}
NF204~NF210	± 0.5	0.7
NF211~NF212	± 0.8	1

Variations of tolerance of bolt hole diameter (ΔN_s)

Housing No.	ΔN_s
NF204~NF212	± 0.2

Shaft Dia mm inch <i>d</i>	Dimensions inch mm										Bolt Size inch	Unit No.	Housing No.	Bearing No.	Basic Load Ratings kN		Factor <i>f</i> ₀	Mass kg																																			
	<i>L</i>	<i>A</i>	<i>J</i>	<i>N</i>	<i>A</i> ₁	<i>A</i> ₂	<i>A</i> ₀	<i>B</i> ₁	<i>S</i>	<i>C</i> _r					<i>C</i> _{0r}																																						
12 15 17 20 1/2 5/8 3/4	3 3/8 86	1 5/32 29.5	2 33/64 64	7/16 11	19/32 15	3/4 19	1 25/32 45.6	1.720 43.7	0.673 17.1	3/8	NANF201 NANF201-8 NANF202 NANF202-10 NANF203 NANF204-12 NANF204	NF204	NA201 NA201-8 NA202 NA202-10 NA203 NA204-12 NA204	12.8	6.65	13.2	0.73																																				
																		25 7/8 15/16 1	3 3/4 95	1 7/32 31	2 3/4 70	15/32 12	19/32 15	25/32 20	1 27/32 46.9	1.748 44.4	0.689 17.5	7/16	NANF205-14 NANF205-15 NANF205 NANF205-16 NANF206-18	NF205	NA205-14 NA205-15 NA205 NA205-16	14.0	7.85	13.9	0.95																		
																																				30 1 3/16 1 1/4	4 1/4 108	1 11/32 34	3 17/64 83	33/64 13	5/8 16	53/64 21	2 51.1	1.906 48.4	0.720 18.3	7/16	NANF206 NANF206-19 NANF206-20	NF206	NA206-18 NA206 NA206-19 NA206-20	19.5	11.3	13.9	1.4
40 1 1/2 1 9/16	5 1/8 130	1 17/32 39	4 1/64 102	35/64 14	21/32 17	15/16 24	2 5/16 58.9	2.217 56.3	0.843 21.4	1/2	NANF208-24 NANF208-25 NANF208	NF208	NA208-24 NA208-25 NA208	29.1	17.8	14.0	2.2																																				
																		45 1 5/8 1 11/16 1 3/4	5 13/32 137	1 9/16 40	4 9/64 105	5/8 16	23/32 18	15/16 24	2 5/16 58.9	2.217 56.3	0.843 21.4	9/16	NANF209-26 NANF209-27 NANF209-28 NANF209	NF209	NA209-26 NA209-27 NA209-28 NA209	34.1	21.3	14.0	2.6																		
50 1 7/8 1 15/16 2	5 5/8 143	1 27/32 46.5	4 3/8 111	43/64 17	25/32 20	1 1/8 28.5	2 5/8 66.6	2.469 62.7	0.969 24.6	9/16	NANF210-30 NANF210-31 NANF210 NANF210-32	NF210	NA210-30 NA210-31 NA210 NA210-32	35.1	23.3	14.4	3.0																																				
																		55 2 2 1/8 2 3/16	6 3/8 162	1 31/32 50	5 1/8 130	43/64 17	13/16 21	1 17/64 32	2 31/32 75.6	2.811 71.4	1.094 27.8	5/8	NANF211-32 NANF211-34 NANF211 NANF211-35	NF211	NA211-32 NA211-34 NA211 NA211-35	43.4	29.4	14.4	4.1																		
60 2 1/4 2 3/8 2 7/16	6 7/8 175	2 5/32 55	5 5/8 143	43/64 17	13/16 21	1 27/64 36	3 1/4 82.8	3.063 77.8	1.220 31	5/8	NANF212-36 NANF212 NANF212-38 NANF212-39	NF212	NA212-36 NA212 NA212-38 NA212-39	52.4	36.2	14.4	4.9																																				

Remarks
 1. In Part No. of unit and units with covers, fitting codes follow bore diameter numbers. (See Table 10.5 in P.62.)
 2. Part No. of applicable grease fittings are shown below.
 A-1/4-28UNF 201~210
 A-R1/8..... 211~212

3. For the dimensions and forms of applicable bearings, see the dimensional tables of ball bearing for unit.
 4. Housings of nodular graphite cast iron are also available.

4-Bolt Flange Units

NCF
Cylindrical bore
(with concentric locking collar)
 d 20 ~ 60 mm

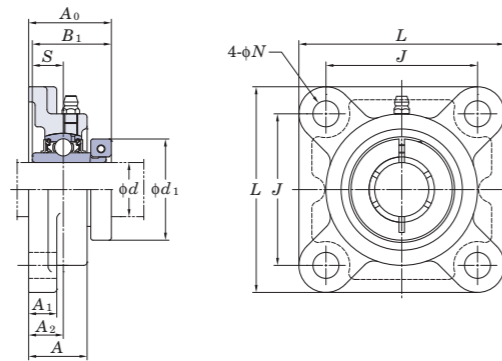

Variations of tolerance of distance from mounting surface to center of spherical bore (ΔA_{2s}) and tolerance of position of bolt hole (X)

Housing No.	ΔA_{2s}	X
F204~F210	± 0.5	0.7
F211~F212	± 0.8	1

Variations of tolerance of bolt hole diameter (ΔN_s)

Housing No.	ΔN_s
F204~F212	± 0.2

Shaft Dia. mm inch d	Dimensions inch mm											Bolt Size inch mm	Unit No.	Housing No.	Bearing No.	Basic Load Ratings kN		Factor f_0	Mass kg
	L	A	J	N	A_1	A_2	A_0	B_1	S	d_1	C_r					C_{0r}			
20 $\frac{3}{4}$	$3\frac{3}{8}$ 86	1 25.5	$2\frac{33}{64}$ 64	$\frac{15}{32}$ 12	$\frac{7}{16}$ 11	$\frac{19}{32}$ 15	$1\frac{3}{8}$ 34.8	$1\frac{9}{32}$ 32.5	0.500 12.7	$1\frac{3}{4}$ 44.5	$\frac{3}{8}$ M10	NCF204-12 NCF204	F204	NC204-12 NC204	12.8	6.65	13.2	0.73	
25 $\frac{7}{8}$ $\frac{15}{16}$	$3\frac{3}{4}$ 95	$1\frac{1}{16}$ 27	$2\frac{3}{4}$ 70	$\frac{15}{32}$ 12	$\frac{1}{2}$ 13	$\frac{5}{8}$ 16	$1\frac{1}{2}$ 38.2	$1\frac{7}{16}$ 36.5	0.563 14.3	$1\frac{15}{16}$ 49.2	$\frac{3}{8}$ M10	NCF205-14 NCF205-15 NCF205 NCF205-16	F205	NC205-14 NC205-15 NC205 NC205-16	14.0	7.85	13.9	1.0	
30 $1\frac{1}{8}$ $1\frac{3}{16}$ $1\frac{1}{4}$	$4\frac{1}{4}$ 108	$1\frac{7}{32}$ 31	$3\frac{17}{64}$ 83	$\frac{15}{32}$ 12	$\frac{1}{2}$ 13	$\frac{45}{64}$ 18	$1\frac{21}{32}$ 41.8	$1\frac{9}{16}$ 39.7	0.626 15.9	$2\frac{3}{16}$ 55.6	$\frac{3}{8}$ M10	NCF206-18 NCF206 NCF206-19 NCF206-20	F206	NC206-18 NC206 NC206-19 NC206-20	19.5	11.3	13.9	1.3	
35 $1\frac{1}{4}$ $1\frac{3}{8}$ $1\frac{7}{16}$	$4\frac{19}{32}$ 117	$1\frac{11}{32}$ 34	$3\frac{5}{8}$ 92	$\frac{35}{64}$ 14	$\frac{19}{32}$ 15	$\frac{3}{4}$ 19	$1\frac{13}{16}$ 46	$1\frac{3}{4}$ 44.5	0.689 17.5	$2\frac{7}{16}$ 61.9	$\frac{7}{16}$ M12	NCF207-20 NCF207-22 NCF207 NCF207-23	F207	NC207-20 NC207-22 NC207 NC207-23	25.7	15.4	13.9	1.8	
40 $1\frac{1}{2}$	$5\frac{1}{8}$ 130	$1\frac{13}{32}$ 36	$4\frac{1}{64}$ 102	$\frac{5}{8}$ 16	$\frac{19}{32}$ 15	$\frac{53}{64}$ 21	$2\frac{3}{32}$ 52.8	2 50.8	0.748 19	$2\frac{11}{16}$ 68.3	$\frac{1}{2}$ M14	NCF208-24 NCF208	F208	NC208-24 NC208	29.1	17.8	14.0	2.3	
45 $1\frac{5}{8}$ $1\frac{11}{16}$ $1\frac{3}{4}$	$5\frac{13}{32}$ 137	$1\frac{1}{2}$ 38	$4\frac{9}{64}$ 105	$\frac{5}{8}$ 16	$\frac{5}{8}$ 16	$\frac{55}{64}$ 22	$2\frac{1}{8}$ 53.8	2 50.8	0.748 19	$2\frac{13}{16}$ 71.4	$\frac{1}{2}$ M14	NCF209-26 NCF209-27 NCF209-28 NCF209	F209	NC209-26 NC209-27 NC209-28 NC209	34.1	21.3	14.0	2.6	
50 $1\frac{15}{16}$ 2	$5\frac{5}{8}$ 143	$1\frac{9}{16}$ 40	$4\frac{3}{8}$ 111	$\frac{5}{8}$ 16	$\frac{5}{8}$ 16	$\frac{55}{64}$ 22	$2\frac{7}{32}$ 56.1	$2\frac{3}{32}$ 53.1	0.748 19	$3\frac{3}{8}$ 85.7	$\frac{1}{2}$ M14	NCF210-31 NCF210 NCF210-32	F210	NC210-31 NC210 NC210-32	35.1	23.3	14.4	3.1	
55 $2\frac{3}{16}$	$6\frac{3}{8}$ 162	$1\frac{11}{16}$ 43	$5\frac{1}{8}$ 130	$\frac{3}{4}$ 19	$\frac{23}{32}$ 18	$\frac{63}{64}$ 25	$2\frac{11}{32}$ 59.9	$2\frac{1}{4}$ 57.1	0.874 22.2	$3\frac{1}{2}$ 88.9	$\frac{5}{8}$ M16	NCF211-32 NCF211 NCF211-35	F211	NC211-32 NC211 NC211-35	43.4	29.4	14.4	3.8	
60 $2\frac{1}{4}$ $2\frac{7}{16}$	$6\frac{7}{8}$ 175	$1\frac{7}{8}$ 48	$5\frac{5}{8}$ 143	$\frac{3}{4}$ 19	$\frac{23}{32}$ 18	$\frac{19}{64}$ 29	$2\frac{25}{32}$ 70.3	$2\frac{5}{8}$ 66.7	1.000 25.4	$4\frac{1}{16}$ 103.2	$\frac{5}{8}$ M16	NCF212-36 NCF212 NCF212-39	F212	NC212-36 NC212 NC212-39	52.4	36.2	14.4	4.9	

Remarks 1. In Part No. of unit, fitting codes follow bore diameter codes. (See Table 10.5 in P.62.)
2. Part No. of applicable grease fittings are shown below.
A-1/4-28UNF 204~210
A-R1/8 211~212

3. For the dimensions and forms of applicable bearings, see the dimensional tables of ball bearing for unit.
4. Representative examples of the forms of housing are indicated.

NCF-E
Cylindrical bore
(with concentric locking collar)
d 20 ~ 60 mm

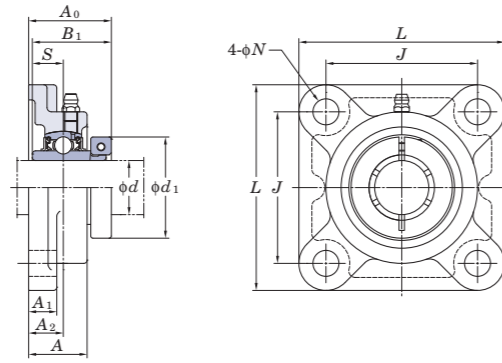

Shaft Dia. mm inch	d	Dimensions										Bolt Size inch	Unit No.	Housing No.	Bearing No.	Basic Load Ratings		Factor	Mass
		L	A	J	N	A ₁	A ₂	A ₀	B ₁	S	d ₁					C _r	C _{0r}		
20	3/4	3 3/8	1	2 33/64	7/16	7/16	19/32	1 3/8	1 9/32	0.500	1 3/4	3/8	NCF204-12E NCF204E	F204E	NC204-12 NC204	12.8	6.65	13.2	0.73
	7/8	86	25.5	64	11	11	15	34.8	32.5	12.7	44.5	3/8	NCF205-14E NCF205-15E NCF205E NCF205-16E	F205E	NC205-14 NC205-15 NC205 NC205-16	14.0	7.85	13.9	1.0
25	1	3 3/4	1 1/16	2 3/4	15/32	1/2	5/8	1 1/2	1 7/16	0.563	1 15/16	3/8	NCF206-18E NCF206E NCF206-19E NCF206-20E	F206E	NC206-18 NC206 NC206-19 NC206-20	19.5	11.3	13.9	1.3
	1 1/8	108	31	83	13	13	18	41.8	39.7	15.9	55.6	7/16	NCF207-20E	F207E	NC207-20	25.7	15.4	13.9	1.8
30	1 1/4	4 19/32	1 11/32	3 5/8	33/64	19/32	3/4	1 13/16	1 3/4	0.689	2 7/16	7/16	NCF207-22E NCF207E NCF207-23E	F207E	NC207-22 NC207 NC207-23	25.7	15.4	13.9	1.8
	1 3/8	117	34	92	13	15	19	46	44.5	17.5	65.1	7/16	NCF208-24E NCF208E	F208E	NC208-24 NC208	29.1	17.8	14.0	2.3
35	1 7/8	5 1/8	1 13/32	4 1/4	35/64	19/32	53/64	2 3/32	2	0.748	2 11/16	1/2	NCF209-26E	F209E	NC209-26	34.1	21.3	14.0	2.6
	1 1/2	130	36	102	14	15	21	52.8	50.8	19	68.3	1/2	NCF209-27E NCF209-28E NCF209E	F209E	NC209-27 NC209-28 NC209	34.1	21.3	14.0	2.6
40	1 5/8	5 13/32	1 1/2	4 9/16	5/8	5/8	55/64	2 1/8	2	0.748	2 13/16	1/2	NCF210-31E NCF210E NCF210-32E	F210E	NC210-31 NC210 NC210-32	35.1	23.3	14.4	3.1
	1 7/8	137	38	105	16	16	22	53.8	50.8	19	71.4	1/2	NCF211-32E	F211E	NC211-32	43.4	29.4	14.4	3.8
45	1 3/4	6 3/8	1 11/16	5 1/8	43/64	23/32	63/64	2 11/32	2 1/4	0.874	3 1/2	5/8	NCF211E NCF211-35E	F211E	NC211 NC211-35	43.4	29.4	14.4	3.8
	1 15/16	162	43	130	17	18	25	59.9	57.1	22.2	88.9	5/8	NCF212-36E	F212E	NC212-36	52.4	36.2	14.4	4.9
50	2	6 7/8	1 7/8	5 5/8	43/64	23/32	1 9/64	2 25/32	2 5/8	1.000	4 1/16	5/8	NCF212E NCF212-39E	F212E	NC212 NC212-39	52.4	36.2	14.4	4.9
	2 1/4	175	48	143	17	18	29	70.3	66.7	25.4	103.2	5/8							
55	2 3/8	175	48	143	17	18	29	70.3	66.7	25.4	104.8	5/8							
	2 1/4	175	48	143	17	18	29	70.3	66.7	25.4	104.8	5/8							
60	2 7/8	175	48	143	17	18	29	70.3	66.7	25.4	104.8	5/8							

Remarks 1. In Part No. of unit, fitting codes follow bore diameter codes. (See Table 10.5 in P.62.)
2. Part No. of applicable grease fittings are shown below.
A-1/4-28UNF 204~208
A-R1/8 211~212

3. For the dimensions and forms of applicable bearings, see the dimensional tables of ball bearing for unit.
4. Representative examples of the forms of housing are indicated.

Variations of tolerance of distance from mounting surface to center of spherical bore (ΔA_{2s}) and tolerance of position of bolt hole (X)

Housing No.	ΔA_{2s}	X
F204E~F208E	± 0.5	0.7
F211E~F212E	± 0.8	1

Variations of tolerance of bolt hole diameter (ΔN_s)

Housing No.	ΔN_s
F204E~F212E	± 0.2

UKF
Tapered bore (with adapter)
 d_1 (90) ~ 125 mm

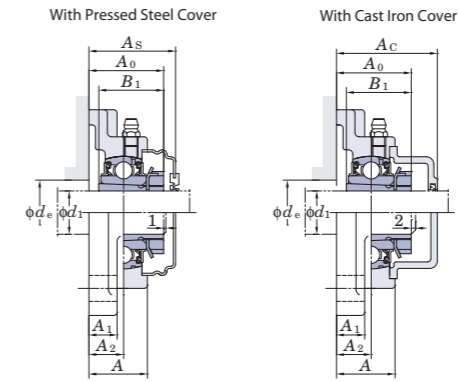
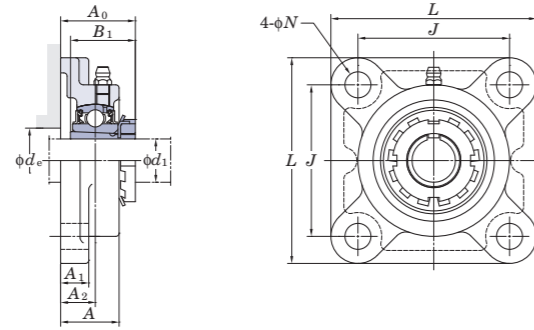

Variations of tolerance of distance from mounting surface to center of spherical bore (ΔA_{2s}) and tolerance of position of bolt hole (X)

Housing No.			ΔA_{2s}	X
F205~F210	FX05~FX10	F305~F310	±0.5	0.7
F211~F218	FX11~FX20	F311~F328	±0.8	1

Variations of tolerance of bolt hole diameter (ΔN_s)

Housing No.			ΔN_s
F205~F218	FX05~FX18	F305~F315	±0.2
	FX20	F316~F328	±0.3

Shaft Dia. mm inch	Dimensions inch mm										Bolt Size inch mm	Standard			Adapter No.	Mass kg	Basic			Factor f_0	With Pressed Steel Cover			With Cast Iron Cover		
	L	A	J	N	A_1	A_2	A_0	B_1	d_e (min.)	Unit No.		Housing No.	Bearing No.	Load Ratings kN C_r C_{0r}			Unit No. Open Type Closed Type	Dimension mm inch A_s	Mass kg		Unit No. Open Type Closed Type	Dimension mm inch A_c	Mass kg			
90 3 1/2	12 7/32	3 11/16	9 17/32	1 1/2	1 1/4	2 21/64	4 7/16	3 13/16	—	1 1/4	UKF320	F320	UK320	173 141	13.2	—	—	—	—	—						
	310	94	242	38	32	59	113	97	—	M33						HE2320X H2320X	25.4 25.4	UKF320C UKF320D	146 5 3/4	28.5						
100 4	13 3/8	3 25/32	10 15/32	1 39/64	1 3/8	2 23/64	4 23/32	4 1/8	—	1 3/8	UKF322	F322	UK322	205 180	13.2	—	—	—	—	—						
	340	96	266	41	35	60	120	105	—	M36						H2322X HE2322X	35.2 35.2	UKF322C UKF322D	154 6 1/16	38.7						
110 —	14 9/16	4 11/32	11 27/64	1 39/64	1 9/16	2 9/16	5 1/8	4 13/32	—	1 3/8	UKF324	F324	UK324	207 185	13.5	—	—	—	—	—						
	370	110	290	41	40	65	130.5	112	—	M36						H2324	47.6	UKF324C UKF324D	163 6 13/32	52.7						
115 4 1/2	16 5/32	4 17/32	12 19/32	1 39/64	1 25/32	2 9/16	5 3/16	4 3/4	—	1 3/8	UKF326	F326	UK326	229 214	13.6	—	—	—	—	—						
	410	115	320	41	45	65	131.5	121	—	M36						HE2326 H2326	65.3 65.3	UKF326C UKF326D	172 6 25/32	71.9						
125 —	17 23/32	4 29/32	13 25/32	1 39/64	2 5/32	2 61/64	5 13/16	5 5/32	—	1 3/8	UKF328	F328	UK328	253 246	13.6	—	—	—	—	—						
	450	125	350	41	55	75	147.5	131	—	M36						H2328	74.9	UKF328C UKF328D	186 7 5/16	83.5						

Remarks 1. In Part No. of unit and units with covers, fitting codes follow bore diameter numbers. (See Table 10.5 in P.62.)
2. Part No. of applicable grease fittings are shown below.
A-1/4-28UNF 205~210, X05~X09, 305~308
A-R1/8 211~218, X10~X20, 309~328

3. In Part No. of unit with adapters and bearing with adapters, Part No. of applicable adapter follow the Part No. shown in the dimensional tables. (Example of Part No. : UKF206J + H2306X, UK206 + H2306X)
4. As for the triple seal type product (205 is the double seal type product), suffix code L3 (L2) follows the Part No. of unit or bearing. (Example of Part No. : UKF206JL3 + H2306X, UK206L3 + H2306X)
5. For the dimensions and forms of applicable bearings and adapters, see the dimensional tables of ball bearing for unit and adapter.
6. Housings of nodular graphite cast iron are also available.

Narrow Inner Ring Bearing 4-Bolt Flange Units

SBF-RKP8
Cylindrical bore
(with set screws)
d 20 ~ 55 mm

SAF-FP9
Cylindrical bore
(with eccentric locking collar)

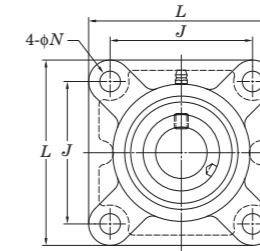
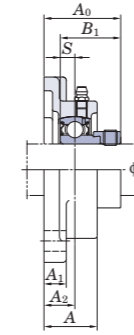
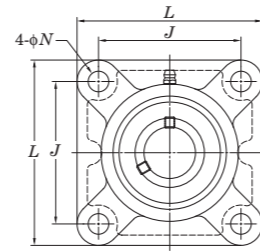
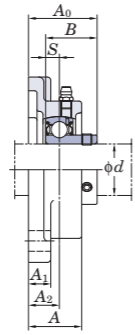

Variations of tolerance of distance from mounting surface to center of spherical bore (ΔA_{2s}) and tolerance of position of bolt hole (X)
Unit: mm

Housing No.	ΔA_{2s}	X
F204~F210	±0.5	0.7
F211	±0.8	1

Variations of tolerance of bolt hole diameter (ΔN_s)
Unit: mm

Housing No.	ΔN_s
F204~F211	±0.2

Shaft Dia. mm inch	Dimensions inch mm										Bolt Size inch mm	Unit No.	Bearing No.	Unit No.	Bearing No.	Housing No.	Basic Load Ratings kN		Factor f_0	Mass kg		
	d	L	A	J	N	A_1	A_2	A_0	B	B_1							SBF-RKP8 S	SAF-FP9 S		C_r	C_{0r}	SBF-RKP8
20 3/4	3 3/8	1	2 33/64	15/32	7/16	19/32	1 17/32	0.984	1.220	0.276	0.295	3/8	SBF204-12RKP8 SBF204RKP8	SB204-12RKP8 SB204RKP8	SAF204-12FP9 SAF204FP9	SA204-12FP9 SA204FP9	F204	12.8	6.65	13.2	0.58	0.62
	86	25.5	64	12	11	15	38.5	25	31	7	7.5	M10										
25 7/8 1 15/16	3 3/4	1 1/16	2 3/4	15/32	1/2	5/8	1 9/16	1.063	1.220	0.295	0.295	3/8	SBF205-14RKP8 SBF205-15RKP8 SBF205-16RKP8 SBF205RKP8	SB205-14RKP8 SB205-15RKP8 SB205-16RKP8 SB205RKP8	SAF205-14FP9 SAF205-15FP9 SAF205-16FP9 SAF205FP9	SA205-14FP9 SA205-15FP9 SA205-16FP9 SA205FP9	F205	14.0	7.85	13.9	0.81	0.86
	95	27	70	12	13	16	39.5	27	31	7.5	7.5	M10										
30 1 1/8 1 3/16 1 1/4	4 1/4	1 7/32	3 17/64	15/32	1/2	45/64	1 3/4	1.181	1.906	0.315	0.354	3/8	SBF206-18RKP8 SBF206-19RKP8 SBF206-20RKP8 SBF206RKP8	SB206-18RKP8 SB206-19RKP8 SB206-20RKP8 SB206RKP8	SAF206-18FP9 SAF206-19FP9 SAF206-20FP9 SAF206FP9	SA206-18FP9 SA206-19FP9 SA206-20FP9 SA206FP9	F206	19.5	11.3	13.9	1.05	1.12
	108	31	83	12	13	18	44.7	30	35.7	8	9	M10										
35 1 1/4 1 5/16 1 3/8 1 7/16	4 19/32	1 11/32	3 5/8	35/64	19/32	3/4	1 29/32	1.260	1.531	0.335	0.374	7/16	SBF207-20RKP8 SBF207-22RKP8 SBF207-23RKP8 SBF207RKP8	SB207-20RKP8 SB207-22RKP8 SB207-23RKP8 SB207RKP8	SAF207-20FP9 SAF207-21FP9 SAF207-22FP9 SAF207-23FP9 SAF207FP9	SA207-20FP9 SA207-21FP9 SA207-22FP9 SA207-23FP9 SA207FP9	F207	25.7	15.4	13.9	1.44	1.59
	117	34	92	14	15	19	48.4	32	38.9	8.5	9.5	M12										
40 1 1/2 1 9/16	5 1/8	1 13/32	4 1/64	5/8	19/32	53/64	2 1/8	1.339	1.720	0.354	0.433	1/2	SBF208-24RKP8 SBF208RKP8	SB208-24RKP8 SB208RKP8	SAF208-24FP9 SAF208FP9	SA208-24FP9 SA208FP9	F208	29.1	17.8	14.0	1.86	2.01
	130	36	102	16	15	21	53.7	34	43.7	9	11	M14										
45 1 5/8 1 11/16 1 3/4	5 13/32	1 1/2	4 9/64	5/8	5/8	55/64	2 5/32	-	1.720	-	0.433	1/2	-	-	SAF209-26FP9 SAF209-27FP9 SAF209-28FP9 SAF209FP9	SA209-26FP9 SA209-27FP9 SA209-28FP9 SA209FP9	F209	34.1	21.3	14.0	-	2.34
	137	38	105	16	16	22	54.7	-	43.7	-	11	M14										
50 1 7/8 1 15/16	5 5/8	1 9/16	4 3/8	5/8	5/8	55/64	2 5/32	-	1.720	-	0.433	1/2	-	-	SAF210-30FP9 SAF210-31FP9 SAF210FP9	SA210-30FP9 SA210-31FP9 SA210FP9	F210	35.1	23.3	14.4	-	2.55
	143	40	111	16	16	22	54.7	-	43.7	-	11	M14										
55 2 2 1/8 2 3/16	6 3/8	1 11/16	5 1/8	3/4	23/32	63/64	2 13/32	-	1.906	-	0.472	5/8	-	-	SAF211-32FP9 SAF211-34FP9 SAF211-35FP9 SAF211FP9	SA211-32FP9 SA211-34FP9 SA211-35FP9 SA211FP9	F211	43.4	29.4	14.4	-	3.49
	162	43	130	19	18	25	61.4	-	48.4	-	12	M16										

Remarks 1. In Part No. of unit, fitting codes follow bore diameter numbers. (See Table 10.5 in P.62.)
2. Part No. of applicable grease fittings are shown below.
A-1/4-28UNF 204~210
A-R1/8 211

3. For the dimensions and forms of applicable bearings, see the dimensional tables of ball bearing for unit.
4. Housings of nodular graphite cast iron are also available.

UCVF-S6
Cylindrical bore (with set screws)
d 20 ~ 40 mm

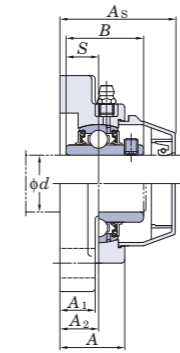
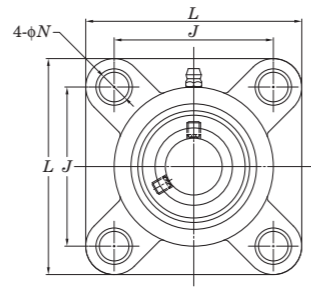
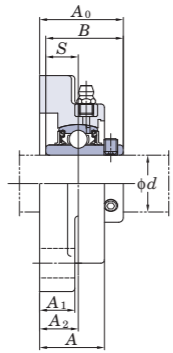

Variations of tolerance of distance from mounting surface to center of spherical bore (ΔA_{2s}) and tolerance of position of bolt hole (X)

Housing No.	Unit: mm	
	ΔA_{2s}	X
VF204~VF208	± 0.5	0.7

Shaft Dia. mm inch	mm inch	Dimensions										Bolt Size inch mm	Standard			Mass kg	Basic Load Ratings kN		Factor f_0	With Plastic Cover										
		L	inch mm								A		J	N	A ₁		A ₂	A ₀		B	S	Unit No.	Housing No.	Bearing No.	C _r	C _{0r}	Unit No.		Dimension mm inch	Mass kg
			A ₁	A ₂	A ₀	B	S	Open Type	Closed Type																					
20	3/4	3 3/8	1 3/32	2 1/2	7/16	17/32	45/64	1 7/16	1.220	0.500	3/8	UCVF204-12S6 UCVF204S6	VF204	UC204-12S6 UC204S6	0.3	10.9	5.35	13.2	UCVF204-12CS6	UCVF204-12DS6	48	1 7/8	0.31							
	86	27.8	63.5	11	13.4	18	36.3	31	12.7	M10	UC205-14S6 UC205-15S6 UC205S6	VF205	UC205-14S6 UC205-15S6 UC205S6	UCVF204CS6					UCVF204DS6	UCVF205-14CS6				UCVF205-14DS6	50.7	2	0.42			
25	7/8	3 3/4	1 1/8	2 3/4	7/16	5/8	43/64	1 7/16	1.343	0.563	3/8	UCVF205-14S6 UCVF205-15S6 UCVF205S6 UCVF205-16S6	VF206	UC206-18S6	0.41	11.9	6.3	13.9	UCVF205-16CS6	UCVF205-16DS6	58.3	1 9/32	0.57							
	1	95	28.5	70	11	15.5	17	36.8	34.1	14.3	M10	UC206-19S6 UC206-20S6		UC206-18S6 UC206S6 UC206-19S6 UC206-20S6					UCVF206-18CS6	UCVF206-18DS6				UCVF206-19CS6	UCVF206-19DS6	63.7	2 1/2	0.85		
30	1 1/8	4 7/32	1 1/4	3 17/64	7/16	9/16	3/4	1 5/8	1.500	0.626	3/8	UCVF206-18S6 UCVF206S6 UCVF206-19S6 UCVF206-20S6	VF207	UC207-20S6	0.56	16.5	9.05	13.9	UCVF206-20CS6	UCVF206-20DS6	70.7	2 25/32	1.11							
	1 3/16	107	31.7	83	11	14.5	19.2	41.4	38.1	15.9	M10	UC207-21S6 UC207-22S6 UC207S6		UC207-20S6 UC207S6 UC207-21S6 UC207-22S6 UC207S6					UCVF207-20CS6	UCVF207-20DS6				UCVF207-21CS6	UCVF207-21DS6	63.7	2 1/2	0.85		
35	1 1/4	4 21/32	1 11/32	3 5/8	33/64	5/8	27/32	1 27/32	1.689	0.689	1/2	UCVF207-20S6 UCVF207-21S6 UCVF207-22S6 UCVF207S6 UCVF207-23S6	VF208	UC208-24S6	0.83	21.8	12.3	13.9	UCVF207-23CS6	UCVF207-23DS6	70.7	2 25/32	1.11							
	1 5/16	118	34.5	92	13	15.5	21.5	46.9	42.9	17.5	M12	UC208-25S6 UC208S6		UC208-24S6 UC208-25S6 UC208S6					UCVF208-24CS6	UCVF208-24DS6				UCVF208-25CS6	UCVF208-25DS6	70.7	2 25/32	1.11		
40	1 7/16	5 1/8	1 7/16	4 1/64	35/64	21/32	29/32	2 3/32	1.937	0.748	1/2	UCVF208-24S6 UCVF208-25S6 UCVF208S6			1.08	24.8	14.3	14.0												
	1 1/2	130	36.5	102	14	17	23	53.2	49.2	19	M12																			

Remarks
1. In Part No. of unit and units with covers, fitting codes follow bore diameter numbers. (See Table 10.5 in P.62.)
2. Part No. of the applicable grease fitting is A-1/4-28UNFN12.
3. For the dimensions and forms of applicable bearings, see the dimensional tables of ball bearing for unit.

UCVF-ES7
Cylindrical bore (with set screws)
d 20 ~ 40 mm

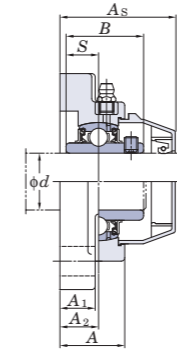
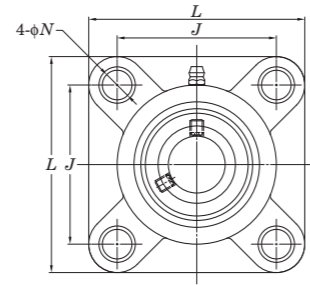
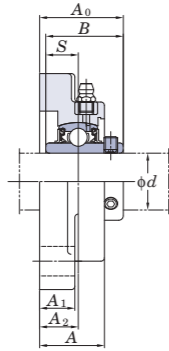

Variations of tolerance of distance from mounting surface to center of spherical bore (ΔA_{2s}) and tolerance of position of bolt hole (X)

Housing No.	ΔA _{2s}	X
VF204E~VF208E	±0.5	0.7

Unit: mm

Shaft Dia. mm inch <i>d</i>	Dimensions inch mm										Bolt Size inch mm	Standard			Mass kg	Basic Load Ratings kN		Factor <i>f</i> ₀	With Plastic Cover																	
	<i>L</i>	<i>A</i>	<i>J</i>	<i>N</i>	<i>A</i> ₁	<i>A</i> ₂	<i>A</i> ₀	<i>B</i>	<i>S</i>	Unit No.		Housing No.	Bearing No.	Open Type		Unit No. Closed Type	Dimension mm inch <i>A</i> _s		Mass kg																	
20 3/4	3 3/8	1 3/32	2 1/2	7/16	17/32	45/64	1 7/16	1.220	0.500	3/8	UCVF204-12ES7 UCVF204ES7	VF204E	UC204-12S7 UC204S7		12.8	6.65	13.2	UCVF204-12ECS7 UCVF204ECS7	UCVF204-12EDS7 UCVF204EDS7	48	1 7/8	0.31														
	86	27.8	63.5	11	13.4	18	36.3	31	12.7	M8																										
25 7/8 15/16 1	3 3/4	1 1/8	2 3/4	7/16	5/8	43/64	1 7/16	1.343	0.563	7/16	UCVF205-14ES7 UCVF205-15ES7 UCVF205ES7 UCVF205-16ES7	VF205E	UC205-14S7 UC205-15S7 UC205S7 UC205-16S7		14.0	7.85	13.9	UCVF205-14ECS7 UCVF205-14ECS7 UCVF205-15ECS7 UCVF205-15ECS7 UCVF205ES7 UCVF205ES7 UCVF205-16ECS7 UCVF205-16EDS7	UCVF205-14EDS7 UCVF205-14EDS7 UCVF205-15EDS7 UCVF205-15EDS7 UCVF205EDS7 UCVF205EDS7 UCVF205-16EDS7 UCVF205-16EDS7	50.7	2	0.42														
	95	28.5	70	11	15.5	17	36.8	34.1	14.3	M10																										
	4 7/32	1 1/4	3 17/64	7/16	9/16	3/4	1 5/8	1.500	0.626	7/16													UCVF206-18ES7 UCVF206ES7 UCVF206-19ES7 UCVF206-20ES7	VF206E	UC206-18S7 UC206S7 UC206-19S7 UC206-20S7		19.5	11.3	13.9	UCVF206-18ECS7 UCVF206ECS7 UCVF206-19ECS7 UCVF206-19EDS7 UCVF206-20ECS7 UCVF206-20EDS7	UCVF206-18EDS7 UCVF206EDS7 UCVF206-19EDS7 UCVF206-19EDS7 UCVF206-20EDS7 UCVF206-20EDS7	58.5	1 5/16	0.57		
	107	31.7	83	11	14.5	19.2	41.4	38.1	15.9	M10																										
1 1/4	1 3/16	1 1/4	1 1/4																																	
35 1 1/4 1 5/16 1 3/8	4 21/32	1 11/32	3 5/8	33/64	5/8	27/32	1 27/32	1.689	0.689	1/2	UCVF207-20ES7 UCVF207-21ES7 UCVF207-22ES7 UCVF207ES7 UCVF207-23ES7	VF207E	UC207-20S7 UC207-21S7 UC207-22S7 UC207S7 UC207-23S7		25.7	15.4	13.9	UCVF207-20ECS7 UCVF207-21ECS7 UCVF207-21ECS7 UCVF207-21ECS7 UCVF207-22ECS7 UCVF207-22EDS7 UCVF207ECS7 UCVF207EDS7 UCVF207-23ECS7 UCVF207-23EDS7	UCVF207-20EDS7 UCVF207-21EDS7 UCVF207-21EDS7 UCVF207-21EDS7 UCVF207-22EDS7 UCVF207-22EDS7 UCVF207EDS7 UCVF207EDS7 UCVF207-23EDS7 UCVF207-23EDS7	63.7	2 1/2	0.85														
	118	34.5	92	13	15.5	21.5	46.9	42.9	17.5	M12																										
	1 1/2	1 3/16	1 1/4	1 1/4																																
	1 3/8	1 1/4	1 1/4	1 1/4																																
40 1 1/2 1 9/16	5 1/8	1 7/16	4 1/64	35/64	21/32	29/32	2 3/32	1.937	0.748	1/2	UCVF208-24ES7 UCVF208-25ES7 UCVF208ES7	VF208E	UC208-24S7 UC208-25S7 UC208S7		29.1	17.8	14.0	UCVF208-24ECS7 UCVF208-24ECS7 UCVF208-25ECS7 UCVF208-25EDS7	UCVF208-24EDS7 UCVF208-24EDS7 UCVF208-25EDS7 UCVF208EDS7	70.7	2 25/32	1.11														
	130	36.5	102	14	17	23	53.2	49.2	19	M12																										

Remarks 1. In Part No. of unit and units with covers, fitting codes follow bore diameter numbers. (See Table 10.5 in P.62.)
2. Part No. of the applicable grease fitting is A-1/4-28UNFN12.
3. For the dimensions and forms of applicable bearings, see the dimensional tables of ball bearing for unit.

UCFL
Cylindrical bore (with set screws)
d (90) ~ 120 mm

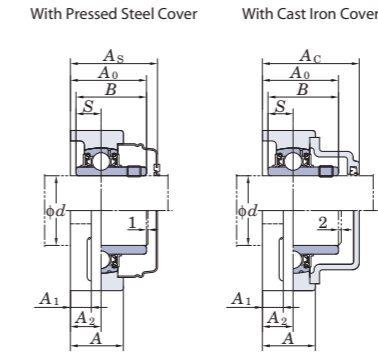
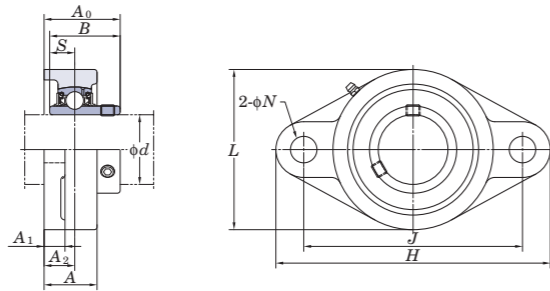

Variations of tolerance of distance from mounting surface to center of spherical bore (ΔA_{2b}) and tolerance of position of bolt hole (X)

Housing No.	ΔA_{2b}	X
FL204~FL210 FL211~FL218	±0.5 ±0.8	0.7 1

Unit: mm

Variations of tolerance of bolt hole diameter (ΔN_b)

Housing No.	ΔN_b
FL204~FL218 FL305~FL311 FL312~FL324	±0.2 ±0.3

Unit: mm

Forms and dimensions of L_c of FL204JE3 and FL205JE3 (housing with cast iron cover) are shown below.



Shaft Dia. mm inch	Dimensions inch mm										Bolt Size inch mm	Standard			Mass kg	Basic Load Ratings kN		Factor f_0	With Pressed Steel Cover				With Cast Iron Cover						
	H	L	A	J	N	A ₁	A ₂	A ₀	B	S		Unit No.	Housing No.	Bearing No.		Unit No. Open Type	Unit No. Closed Type		Dimension mm inch	Mass kg	Unit No. Open Type	Unit No. Closed Type	Dimension mm inch	Mass kg					
90 3 1/2	15 5/32	9 1/4	3	12 13/32	1 1/2	1 13/32	1 47/64	3 15/16	3.780	1.575	1 1/4	UCFL318-56 UCFL318	FL318	UC318-56 UC318		143	107	13.3	-	-	-	-	-	-	-	-	-	-	-
	385	235	76	315	38	36	44	100	96	40	M33											UCFL318C	UCFL318D	119	4 11/16	20.9			
95	15 15/16	9 27/32	3 11/16	13	1 39/64	1 9/16	2 21/64	4 3/4	4.055	1.614	1 3/8	UCFL319	FL319	UC319		153	119	13.3	-	-	-	-	-	-	-	-	-	-	-
	405	250	94	330	41	40	59	121	103	41	M36											UCFL319C	UCFL319D	140	5 1/2	26.8			
100 3 15/16 4	17 5/16	10 5/8	3 11/16	14 11/64	1 47/64	1 9/16	2 21/64	4 29/32	4.252	1.654	1 1/2	UCFL320 UCFL320-63 UCFL320-64	FL320	UC320 UC320-63 UC320-64		173	141	13.2	-	-	-	-	-	-	-	-	-	-	-
	440	270	94	360	44	40	59	125	108	42	M39											UCFL320C	UCFL320D	146	5 3/4	32.2			
110	18 1/2	11 13/16	3 25/32	15 23/64	1 47/64	1 21/32	2 23/64	5 5/32	4.606	1.811	1 1/2	UCFL322	FL322	UC322		205	180	13.2	-	-	-	-	-	-	-	-	-	-	-
	470	300	96	390	44	42	60	131	117	46	M39											UCFL322C	UCFL322D	154	6 1/16	39.6			
120	20 15/32	13	4 11/32	16 59/64	1 27/32	1 7/8	2 9/16	5 1/2	4.961	2.008	1 5/8	UCFL324	FL324	UC324		207	185	13.5	-	-	-	-	-	-	-	-	-	-	-
	520	330	110	430	47	48	65	140	126	51	M42											UCFL324C	UCFL324D	163	6 13/32	56.4			

Remarks 1. In Part No. of unit and units with covers, fitting codes follow bore diameter numbers. (See Table 10.5 in P.62.)

2. Part No. of applicable grease fittings are shown below.

A-1/4-28UNF 201~210, X05~X09, 305~308
A-R1/8 211~218, X10, 309~324

3. As for the triple seal type product (from 201 to 205 are the double seal type products), suffix code L3 (or L2) follows the Part No. of unit or bearing. (Example of Part No. : UCFL206JL3, UC206L3)

4. For the dimensions and forms of applicable bearings, see the dimensional tables of ball bearing for unit.

5. Housings of nodular graphite cast iron are also available.

UCFL-E
Cylindrical bore (with set screws)
 d 80 ~ 85 mm

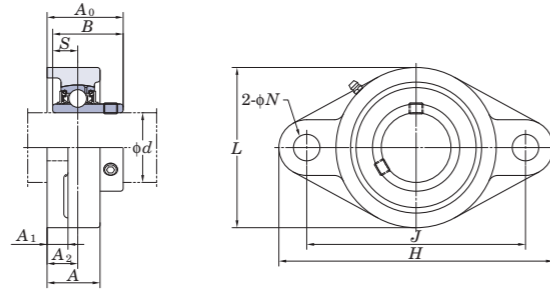

Shaft Dia. mm inch	Dimensions inch mm											Bolt Size inch	Unit No.	Housing No.	Bearing No.	Basic Load Ratings kN		Factor <i>f</i> ₀	Mass kg
	<i>d</i>	<i>H</i>	<i>L</i>	<i>A</i>	<i>J</i>	<i>N</i>	<i>A</i> ₁	<i>A</i> ₂	<i>A</i> ₀	<i>B</i>	<i>S</i>					<i>C</i> _r	<i>C</i> _{0r}		
80 3 1/8	11 13/32	7 3/32	2 9/32	9 11/64	3/4	25/32	1 11/32	3 9/32	3.252	1.311	11/16	UCFL216-50E UCFL216E	FL216E	UC216-50 UC216	72.7	53.0	14.6	7.8	
	290	180	58	233	19	20	34	83.3	82.6	33.3									
85 3 1/4	12	7 15/32	2 15/32	9 49/64	3/4	7/8	1 27/64	3 7/16	3.374	1.343	11/16	UCFL217-52E UCFL217E	FL217E	UC217-52 UC217	84.0	61.9	14.5	9.8	
	305	190	63	248	19	22	36	87.6	85.7	34.1									

Remarks 1. In Part No. of unit, fitting codes follow bore diameter numbers. (See **Table 10.5** in P.62.)
 2. Part No. of applicable grease fittings are shown below.
 A-1/4-28UNF 201~210
 A-R1/8 211~217

3. As for the triple seal type product (from 201 to 205 are the double seal type products), suffix code L3 (or L2) follows the Part No. of unit or bearing. (Example of Part No.: UCFL206EJL3, UC206L3)
 4. For the dimensions and forms of applicable bearings, see the dimensional tables of ball bearing for unit.
 5. Housings of nodular graphite cast iron are also available.

Variations of tolerance of distance from mounting surface to center of spherical bore (ΔA_{2s}) and tolerance of position of bolt hole (X)

Housing No.	ΔA_{2s}	X
FL203E~FL210E	±0.5	0.7
FL211E~FL217E	±0.8	1

Variations of tolerance of bolt hole diameter (ΔN_s)

Housing No.	ΔN_s
FL203E~FL217E	±0.2

NANFL
Cylindrical bore
 (with eccentric locking collar)
 d 12 ~ 55 mm

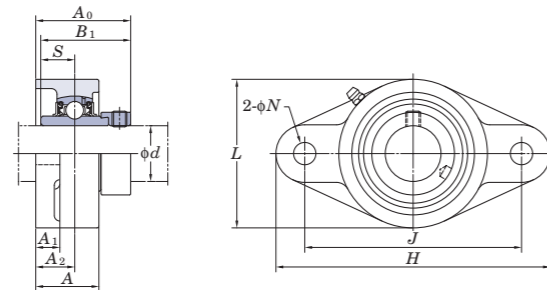

Variations of tolerance of distance from mounting surface to center of spherical bore (ΔA_{2s}) and tolerance of position of bolt hole (X)

		Unit: mm	
Housing No.	ΔA_{2s}	X	
NFL204~NFL210	±0.5	0.7	
NFL211	±0.8	1	

Variations of tolerance of bolt hole diameter (ΔN_h)

		Unit: mm	
Housing No.	ΔN_h		
NFL204~NFL211	±0.2		

Shaft Dia mm inch	Dimensions inch mm	Bolt Size inch	Unit No.	Housing No.	Bearing No.	Basic Load Ratings kN		Factor f_0	Mass kg
						C_r	C_{0r}		
d	H L A J N A_1 A_2 A_0 B_1 S								
12 1/2			NANFL201 NANFL201-8		NA201				
15 5/8	4 7/16 2 3/8 1 5/32 3 17/32 2 5/64 7/16 3/4 1 25/32 1.720 0.673	5/16	NANFL202 NANFL202-10 NANFL203 NANFL204-12 NANFL204	NFL204	NA202 NA202-10 NA203 NA204-12 NA204	12.8	6.65	13.2	0.59
17 3/4									
20									
25 7/8 1 1/16	5 1/8 2 11/16 1 7/32 3 57/64 1 5/32 1/2 2 5/32 1 27/32 1.748 0.689	3/8	NANFL205-14 NANFL205-15 NANFL205 NANFL205-16	NFL205	NA205-14 NA205-15 NA205 NA205-16	14.0	7.85	13.9	0.9
30 1 1/8 1 3/16 1 1/4	5 13/16 3 5/32 1 11/32 4 19/32 1 5/32 1/2 5 3/64 2 1.906 0.720	3/8	NANFL206-18 NANFL206 NANFL206-19 NANFL206-20	NFL206	NA206-18 NA206 NA206-19 NA206-20	19.5	11.3	13.9	1.1
35 1 1/4 1 5/16 1 3/8 1 7/16	6 11/32 3 17/32 1 7/16 5 1/8 3 3/64 9/16 2 7/32 2 1/8 2.012 0.740	7/16	NANFL207-20 NANFL207-21 NANFL207-22 NANFL207 NANFL207-23	NFL207	NA207-20 NA207-21 NA207-22 NA207 NA207-23	25.7	15.4	13.9	1.6
40 1 1/2 1 9/16	6 7/8 3 15/16 1 17/32 5 2 1/32 3 3/64 9/16 1 5/16 2 5/16 2.217 0.843	7/16	NANFL208-24 NANFL208-25 NANFL208	NFL208	NA208-24 NA208-25 NA208	29.1	17.8	14.0	2.0
45 1 5/8 1 11/16 1 3/4	7 13/32 4 1/4 1 9/16 5 27/32 1 9/32 9/16 1 5/16 2 5/16 2.217 0.843	1/2	NANFL209-26 NANFL209-27 NANFL209-28 NANFL209	NFL209	NA209-26 NA209-27 NA209-28 NA209	34.1	21.3	14.0	2.3
50 1 7/8 1 15/16 2	7 3/4 4 17/32 1 27/32 6 3/16 1 9/32 9/16 1 1/8 2 5/8 2.469 0.969	1/2	NANFL210-30 NANFL210-31 NANFL210 NANFL210-32	NFL210	NA210-30 NA210-31 NA210 NA210-32	35.1	23.3	14.4	2.7
55 2 2 1/8 2 3/16	8 13/16 5 1/8 1 31/32 7 1/4 2 1/32 2 5/32 1 17/64 2 31/32 2.811 1.094	9/16	NANFL211-32 NANFL211-34 NANFL211 NANFL211-35	NFL211	NA211-32 NA211-34 NA211 NA211-35	43.4	29.4	14.4	4.1

Remarks 1. In Part No. of unit and units with covers, fitting codes follow bore diameter numbers. (See Table 10.5 in P.62.)
 2. Part No. of applicable grease fittings are shown below.
 A-1/4-28UNF 201~210
 A-R1/8..... 211

3. For the dimensions and forms of applicable bearings, see the dimensional tables of ball bearing for unit.
 4. Housings of nodular graphite cast iron are also available.

NCFL
Cylindrical bore
(with concentric locking collar)
 d 20 ~ 60 mm

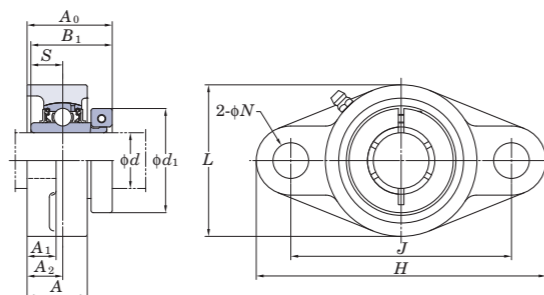

Variations of tolerance of distance from mounting surface to center of spherical bore (ΔA_{2s}) and tolerance of position of bolt hole (X)

Housing No.	ΔA_{2s}	X
FL204~FL210	± 0.5	0.7
FL211~FL212	± 0.8	1

Variations of tolerance of bolt hole diameter (ΔN_s)

Housing No.	ΔN_s
FL204~FL212	± 0.2

Shaft Dia. mm inch d	Dimensions													Bolt Size inch mm	Unit No.	Housing No.	Bearing No.	Basic Load Ratings		Factor f_0	Mass kg
	inch mm																	C_r	C_{0r}		
	H	L	A	J	N	A_1	A_2	A_0	B_1	S	d_1										
20	3/4	4 7/16	2 3/8	1	3 35/64	15/32	7/16	19/32	1 3/8	1 9/32	0.500	1 3/4	3/8	NCFL204-12 NCFL204	FL204	NC204-12 NC204	12.8	6.65	13.2	0.62	
		113	60	25.5	90	12	11	15	34.8	32.5	12.7	44.5	M10								
25	7/8	5 1/8	2 11/16	1 1/16	3 57/64	5/8	1/2	5/8	1 1/2	1 7/16	0.563	1 15/16	1/2	NCFL205-14 NCFL205-15 NCFL205 NCFL205-16	FL205	NC205-14 NC205-15 NC205 NC205-16	14.0	7.85	13.9	0.84	
		130	68	27	99	16	13	16	38.2	36.5	14.3	49.2	M14								
30	1 1/8	5 13/16	3 5/32	1 7/32	4 39/64	5/8	1/2	45/64	1 21/32	1 9/16	0.626	2 3/16	1/2	NCFL206-18 NCFL206 NCFL206-19 NCFL206-20	FL206	NC206-18 NC206 NC206-19 NC206-20	19.5	11.3	13.9	1.1	
		148	80	31	117	16	13	18	41.8	39.7	15.9	55.6	M14								
35	1 1/4	6 11/32	3 17/32	1 11/32	5 1/8	5/8	9/16	3/4	1 13/16	1 3/4	0.689	2 7/16	1/2	NCFL207-20 NCFL207-22 NCFL207 NCFL207-23	FL207	NC207-20 NC207-22 NC207 NC207-23	25.7	15.4	13.9	1.5	
		161	90	34	130	16	14	19	46	44.5	17.5	61.9	M14								
40	1 1/2	6 7/8	3 15/16	1 13/32	5 43/64	5/8	9/16	53/64	2 3/32	2	0.748	2 11/16	1/2	NCFL208-24 NCFL208 NCFL209-26	FL208	NC208-24 NC208 NC209-26	29.1	17.8	14.0	2.0	
		175	100	36	144	16	14	21	52.8	50.8	19	68.3	M14								
45	1 5/8	7 13/32	4 1/4	1 1/2	5 53/64	3/4	19/32	55/64	2 1/8	2	0.748	2 13/16	5/8	NCFL209-27 NCFL209-28 NCFL209	FL209	NC209-27 NC209-28 NC209	34.1	21.3	14.0	2.3	
		188	108	38	148	19	15	22	53.8	50.8	19	71.4	M16								
50	1 15/16	7 3/4	4 17/32	1 9/16	6 3/16	3/4	19/32	55/64	2 7/32	2 3/32	0.748	3 3/8	5/8	NCFL210-31 NCFL210 NCFL210-32	FL210	NC210-31 NC210 NC210-32	35.1	23.3	14.4	2.8	
		197	115	40	157	19	15	22	56.1	53.1	19	85.7	M16								
55	2	8 13/16	5 1/8	1 11/16	7 1/4	3/4	23/32	63/64	2 11/32	2 1/4	0.874	3 1/2	5/8	NCFL211-32 NCFL211 NCFL211-35	FL211	NC211-32 NC211 NC211-35	43.4	29.4	14.4	3.7	
		224	130	43	184	19	18	25	59.9	57.1	22.2	88.9	M16								
60	2 3/16	8 13/16	5 1/8	1 11/16	7 1/4	3/4	23/32	63/64	2 11/32	2 1/4	0.874	3 5/8	5/8	NCFL212-36 NCFL212 NCFL212-39	FL212	NC212-36 NC212 NC212-39	52.4	36.2	14.4	4.9	
		224	130	43	184	19	18	25	59.9	57.1	22.2	92.1	M16								
60	2 1/4	9 27/32	5 1/2	1 7/8	7 61/64	29/32	23/32	1 9/64	2 25/32	2 5/8	1.000	4 1/16	3/4	NCFL212-36 NCFL212 NCFL212-39	FL212	NC212-36 NC212 NC212-39	52.4	36.2	14.4	4.9	
		250	140	48	202	23	18	29	70.3	66.7	25.4	103.2	M20								
	2 7/16	9 27/32	5 1/2	1 7/8	7 61/64	29/32	23/32	1 9/64	2 25/32	2 5/8	1.000	4 1/8	3/4	NCFL212	FL212	NC212	52.4	36.2	14.4	4.9	

Remarks 1. In Part No. of unit, fitting codes follow bore diameter codes. (See Table 10.5 in P.62.)
2. Part No. of applicable grease fittings are shown below.
A-1/4-28UNF..... 204~210
A-R1/8..... 211~212

3. For the dimensions and forms of applicable bearings, see the dimensional tables of ball bearing for unit.
4. Representative examples of the forms of housing are indicated.

NCFL-E
Cylindrical bore
(with concentric locking collar)
 d 20 ~ 60 mm

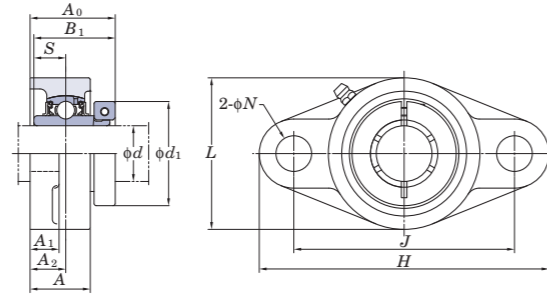

Variations of tolerance of distance from mounting surface to center of spherical bore (ΔA_{2s}) and tolerance of position of bolt hole (X)

Housing No.	ΔA_{2s}	X
FL204E~FL210E	± 0.5	0.7
FL211E~FL212E	± 0.8	1

Variations of tolerance of bolt hole diameter (ΔN_h)

Housing No.	ΔN_h
FL204E~FL212E	± 0.2

Shaft Dia. mm inch	d	Dimensions inch mm											Bolt Size inch	Unit No.	Housing No.	Bearing No.	Basic Load Ratings kN		Factor f_0	Mass kg
		H	L	A	J	N	A_1	A_2	A_0	B_1	S	d_1					C_r	C_{0r}		
20	3/4	4 7/16	2 3/8	1	3 17/32	25/64	7/16	19/32	1 3/8	1 9/32	0.500	1 3/4	5/16	NCFL204-12E NCFL204E	FL204E	NC204-12 NC204	12.8	6.65	13.2	0.62
	113	60	25.5	89.7	10	11	15	34.8	32.5	12.7	44.5	3/8	NCFL205-14E NCFL205-15E NCFL205E NCFL205-16E	FL205E	NC205-14 NC205-15 NC205 NC205-16	14.0	7.85	13.9	0.84	
25	7/8	5 1/8	2 11/16	1 1/16	3 57/64	15/32	1/2	5/8	1 1/2	1 7/16	0.563	1 15/16	3/8	NCFL206-18E NCFL206E NCFL206-19E NCFL206-20E	FL206E	NC206-18 NC206 NC206-19 NC206-20	19.5	11.3	13.9	1.1
	130	68	27	98.8	12	13	16	38.2	36.5	14.3	49.2	7/16	NCFL207-20E	FL207E	NC207-20	25.7	15.4	13.9	1.5	
30	1 1/8	5 13/16	3 5/32	1 7/32	4 19/32	15/32	1/2	45/64	1 21/32	1 9/16	0.626	2 3/16	3/8	NCFL207-22E NCFL207E NCFL207-23E	FL207E	NC207-22 NC207 NC207-23	25.7	15.4	13.9	1.5
	148	80	31	116.7	12	13	18	41.8	39.7	15.9	55.6	7/16	NCFL208-24E NCFL208E	FL208E	NC208-24 NC208	29.1	17.8	14.0	2.0	
35	1 1/4	6 11/32	3 17/32	1 11/32	5 1/8	33/64	9/16	3/4	1 13/16	1 3/4	0.689	2 7/16	7/16	NCFL209-26E	FL209E	NC209-26	34.1	21.3	14.0	2.3
	161	90	34	130.2	13	14	19	46	44.5	17.5	61.9	1/2	NCFL209-27E NCFL209-28E NCFL209E	FL209E	NC209-27 NC209-28 NC209	34.1	21.3	14.0	2.3	
40	1 1/2	6 7/8	3 15/16	1 13/32	5 21/32	33/64	9/16	53/64	2 3/32	2	0.748	2 11/16	7/16	NCFL210-31E NCFL210E NCFL210-32E	FL210E	NC210-31 NC210 NC210-32	35.1	23.3	14.4	2.8
	175	100	36	143.7	13	14	21	52.8	50.8	19	68.3	9/16	NCFL211-32E	FL211E	NC211-32	43.4	29.4	14.4	3.7	
45	1 5/8	7 13/32	4 1/4	1 1/2	5 27/32	19/32	19/32	55/64	2 1/8	2	0.748	2 13/16	1/2	NCFL211E NCFL211-35E	FL211E	NC211 NC211-35	43.4	29.4	14.4	3.7
	188	108	38	148.4	15	15	22	53.8	50.8	19	71.4	9/16	NCFL212-36E	FL212E	NC212-36	52.4	36.2	14.4	4.9	
50	1 11/16	7 3/4	4 17/32	1 9/16	6 3/16	19/32	19/32	55/64	2 7/32	2 3/32	0.748	3 3/8	1/2	NCFL212E NCFL212-39E	FL212E	NC212 NC212-39	52.4	36.2	14.4	4.9
	197	115	40	157	15	15	22	56.1	53.1	19	85.7	9/16								
55	2	8 13/16	5 1/8	1 11/16	7 1/4	21/32	23/32	63/64	2 11/32	2 1/4	0.874	3 1/2	9/16							
	224	130	43	184	16.5	18	25	59.9	57.1	22.2	88.9	9/16								
60	2 3/16	8 13/16	5 1/8	1 11/16	7 1/4	21/32	23/32	63/64	2 11/32	2 1/4	0.874	3 5/8	9/16							
	224	130	43	184	16.5	18	25	59.9	57.1	22.2	92.1	9/16								
60	2 1/4	9 27/32	5 1/2	1 7/8	7 61/64	21/32	23/32	1 9/64	2 25/32	2 5/8	1.000	4 1/16	9/16							
	250	140	48	202	16.5	18	29	70.3	66.7	25.4	103.2	9/16								
60	2 7/16	9 27/32	5 1/2	1 7/8	7 61/64	21/32	23/32	1 9/64	2 25/32	2 5/8	1.000	4 1/8	9/16							
	250	140	48	202	16.5	18	29	70.3	66.7	25.4	104.8	9/16								

Remarks 1. In Part No. of unit, fitting codes follow bore diameter codes. (See **Table 10.5** in P.62.)
2. Part No. of applicable grease fittings are shown below.
A-1/4-28UNF..... 204~210
A-R1/8..... 211~212

3. For the dimensions and forms of applicable bearings, see the dimensional tables of ball bearing for unit.
4. Representative examples of the forms of housing are indicated.

UCFA
Cylindrical bore (with set screws)
d 12 ~ 55 mm

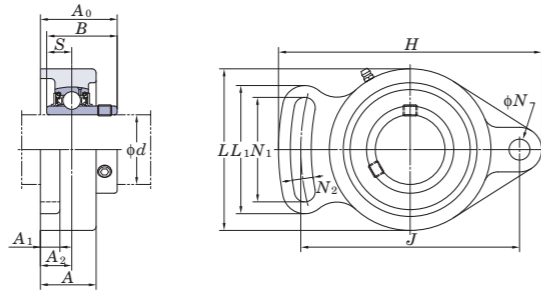

Variations of tolerance of distance from mounting surface to center of spherical bore (ΔA_{2s})

Housing No.	Unit: mm ΔA_{2s}
FA204~FA210	± 0.5
FA211	± 0.8

Variations of tolerance of bolt hole diameter (ΔN_s)

Housing No.	Unit: mm ΔN_s
FA204~FA211	± 0.2

Shaft Dia. mm inch d	Dimensions inch mm													Bolt Size inch mm	Unit No.	Housing No.	Bearing No.	Basic Load Ratings kN		Factor f ₀	Mass kg		
	H	L	A	J	N	N ₁	N ₂	L ₁	A ₁	A ₂	A ₀	B	S					C _r	C _{0r}				
																		C _r	C _{0r}				
12 1/2																UCFA201 UCFA201-8 UCFA202 UCFA202-10 UCFA203 UCFA204-12 UCFA204	FA204	UC201 UC201-8 UC202 UC202-10 UC203 UC204-12 UC204	12.8 6.65	13.2	0.47 0.45 0.44 0.42		
15 5/8	3 27/32	2 5/16	15/16	3 5/64	25/64	1 9/16	13/32	1 31/32	7/16	35/64	1 1/4	1.220	0.500	5/16 M8									
17 3/4	98	59	24	78	10	40	10	50	11	13.8	32.1	31	12.7										
20															UCFA205-14 UCFA205-15 UCFA205 UCFA205-16 UCFA206-18 UCFA206 UCFA206-19 UCFA206-20	FA205	UC205-14 UC205-15 UC205 UC205-16 UC206-18 UC206 UC206-19 UC206-20	14.0 7.85	13.9	0.68			
25 7/8 15/16	4 7/8	2 3/4	1 1/16	3 55/64	7/16	1 15/16	7/16	2 17/32	1/2	5/8	1 13/32	1.343	0.563	3/8 M10									
124	70	27	98	11	49	11	64	13	16	35.8	34.1	14.3											
30 1 1/8 1 3/16 1 1/4	5 9/16	3 9/32	1 3/16	4 39/64	7/16	2 7/32	15/32	2 11/16	1/2	45/64	1 9/16	1.500	0.626	3/8 M10									
141	83	30	117	11	56	12	68	13	17.8	40	38.1	15.9											
35 1 1/4 1 5/16 1 3/8 1 7/16	6 3/32	3 25/32	1 11/32	5 1/8	33/64	2 15/32	1/2	2 15/16	9/16	47/64	1 23/32	1.689	0.689	7/16 M12									
155	96	34	130	13	63	13	75	14	18.6	44	42.9	17.5											
40 1 1/2 1 9/16	6 23/32	4 1/8	1 1/2	5 43/64	33/64	2 3/4	1/2	3 5/16	9/16	13/16	2	1.937	0.748	7/16 M12									
171	105	38	144	13	70	13	84	14	20.8	51	49.2	19											
45 1 5/8 1 11/16 1 3/4	7 1/16	4 3/8	1 9/16	5 53/64	19/32	2 27/32	19/32	3 15/32	9/16	55/64	2 1/16	1.937	0.748	1/2 M14									
179	111	40	148	15	72	15	88	14	21.8	52	49.2	19											
50 1 7/8 1 15/16	7 7/16	4 9/16	1 9/16	6 3/16	19/32	2 15/16	19/32	3 5/8	9/16	57/64	2 5/32	2.031	0.748	1/2 M14									
189	116	40	157	15	75	15	92	14	22.5	55.1	51.6	19											
55 2 2 1/8 2 3/16	8 1/2	5 1/4	1 23/32	7 1/4	5/8	3 3/8	5/8	4 1/32	25/32	1 1/64	2 5/16	2.189	0.874	1/2 M14									
216	133	44	184	16	86	16	102	20	25.7	59.1	55.6	22.2											

Remarks 1. In Part No. of unit and units with covers, fitting codes follow bore diameter numbers. (See Table 10.5 in P.62.)
2. Part No. of applicable grease fittings are shown below.
A-1/4-28UNF 201~210
A-R1/8 211

3. As for triple seal type product (from 201 to 205 are the double seal type products), suffix code L3 (or L2) follows Part No. of unit or bearing. (Example of Part No. : UCFA206JL3, UC206L3)
4. For the dimensions and forms of applicable bearings, see the dimensional tables of ball bearing for unit.
5. Tapered bore (with adapter) type products are also available. (Example of Part No. : UKFA205J + H2305X, UK205 + H2305X)

UCFB
Cylindrical bore (with set screws)
d 12 ~ 50 mm

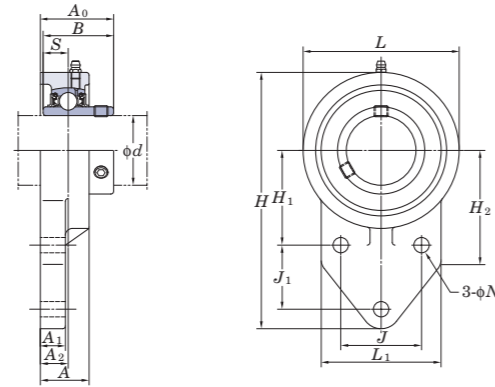

Shaft Dia. mm <i>d</i>	inch	Dimensions														Bolt Size inch mm	Unit No.	Housing No.	Bearing No.	Basic Load Ratings kN		Factor <i>f</i> ₀	Mass kg		
		<i>H</i>	<i>L</i>	<i>A</i>	<i>J</i>	<i>J</i> ₁	<i>N</i>	<i>H</i> ₁	<i>H</i> ₂	<i>L</i> ₁	<i>A</i> ₁	<i>A</i> ₂	<i>A</i> ₀	<i>B</i>	<i>S</i>					<i>C</i> _r	<i>C</i> _{0r}				
12	1/2															5/16	UCFB201	FB204	UC201	12.8	6.65	13.2	0.64		
15	5/8	4 11/32	2 7/16	1 5/16	1 17/64	1 1/16	3/8	1 21/32	2 1/16	2 1/16	1/2	17/32	1 1/4	1.220	0.500	5/16	UCFB201-8		UC201-8				13.2	0.62	
17	3/4	110	62	24.5	32	27	9.5	42	52	52	13	13.5	31.8	31	12.7	M8	UCFB202		UC202					0.61	
20																	M8		UCFB202-10					UC202-10	0.59
25	7/8	4 9/16	2 11/16	1 1/16	1 11/32	1 1/16	3/8	1 49/64	2 1/16	2 7/32	1/2	19/32	1 3/8	1.343	0.563	5/16	UCFB205-14	UC205-14	13.9	0.68					
	15/16	116	68	27	34	27	9.5	45	52	56	13	15	34.8	34.1	14.3	M8	UCFB205-15	UC205-15		13.9	0.92				
30	1																M8	UCFB205				UC205	13.9	0.92	
	1 1/8																M8	UCFB205-16				UC205-16			
30	1 3/16	5 1/8	3 1/16	1 3/16	1 37/64	1 9/64	3/8	1 31/32	2 5/32	2 9/16	1/2	43/64	1 17/32	1.500	0.626	5/16	UCFB206-18	UC206-18	13.9	0.92					
	1 1/4	130	78	30	40	29	9.5	50	55	65	13	17	39.2	38.1	15.9	M8	UCFB206	UC206			13.9	0.92			
35	1 5/16																M8	UCFB206-19					UC206-19	13.9	1.3
	1 3/8																M8	UCFB206-20					UC206-20		
35	1 7/16	5 21/32	3 17/32	1 5/16	1 13/16	1 17/64	3/8	2 11/64	2 7/16	2 3/4	19/32	3/4	1 3/4	1.689	0.689	5/16	UCFB207-20	UC207-20	13.9	1.3					
	1 9/16	144	90	33.5	46	32	9.5	55	62	70	15	19	44.4	42.9	17.5	M8	UCFB207-21	UC207-21			13.9	1.3			
40	1 1/2																M10	UCFB207-22					UC207-22	14.0	1.8
	1 5/8																M10	UCFB207					UC207		
40	1 9/16	6 15/32	3 15/16	1 3/8	1 31/32	1 39/64	7/16	2 23/64	2 27/32	3 1/16	5/8	25/32	1 31/32	1.937	0.748	3/8	UCFB208-24	UC208-24	14.0	1.8					
	1 7/8	164	100	35	50	41	11	60	72	78	16	20	50.2	49.2	19	M10	UCFB208-25	UC208-25			14.0	2.0			
45	1 5/8																M10	UCFB208					UC208	14.0	2.0
	1 11/16																M10	UCFB209-26					UC209-26		
45	1 3/4	6 27/32	4 3/16	1 3/8	2 1/8	1 11/16	7/16	2 9/16	3	3 5/32	23/32	25/32	1 31/32	1.937	0.748	3/8	UCFB209-27	UC209-27	14.0	2.0					
	1 7/8	174	106	35.5	54	43	11	65	76	80	18	20	50.2	49.2	19	M10	UCFB209-28	UC209-28			14.4	2.3			
50	1 7/8																M10	UCFB209					UC209	14.4	2.3
	1 15/16																M10	UCFB210-30					UC210-30		
50	2	7 1/4	4 13/32	1 7/16	2 9/32	1 13/16	7/16	2 43/64	3 7/32	3 3/8	23/32	25/32	2 1/16	2.031	0.748	3/8	UCFB210-31	UC210-31	14.4	2.3					
		184	112	36	58	46	11	68	82	86	18	20	52.6	51.6	19	M10	UCFB210	UC210			14.4	2.3			
																	M10	UCFB210-32					UC210-32		

Remarks 1. In Part No. of unit and units with covers, fitting codes follow bore diameter codes. (See Table 10.5 in P.62.)
 2. Part No. of applicable grease fitting is A-1/4-28UNF.
 3. As for the triple seal type product (from 201 to 205 are the double seal type products), suffix code L3 (or L2) follows Part No. of unit or bearing. (Example of Part No. : UCFB206JL3, UC206L3)

4. For the dimensions and forms of applicable bearings, see the dimensional tables of ball bearing for unit.
 5. Tapered bore (with adapter) type products are also available. (Example of Part No. : UKFB205J + H2305X, UK205 + H2305X)

Variations of tolerance of distance from mounting surface to center of spherical bore (ΔA_{2s}), variations of tolerance of distance between centers of bolt holes (ΔJ_s , ΔJ_{1s}), variations of tolerance of distance between both grooves (ΔH_{1s})

Unit: mm			
Housing No.	ΔA_{2s}	ΔJ_s	ΔH_{1s}
FB204~FB210			±0.5

Variations of tolerance of bolt hole diameter (ΔN_s)

Unit: mm	
Housing No.	ΔN_s
FB204~FB210	±0.2

SBFL-RKP8
Cylindrical bore
(with set screws)
d 20 ~ 55 mm

SAFL-FP9
Cylindrical bore
(with eccentric locking collar)

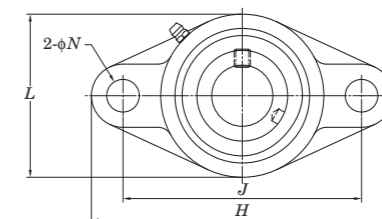
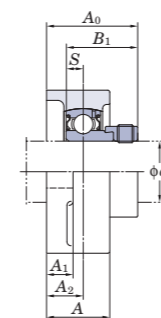
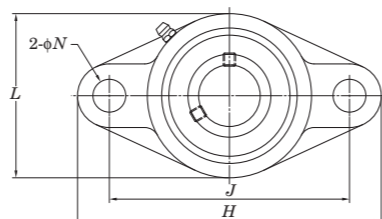
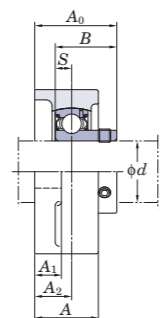

Variations of tolerance of distance from mounting surface to center of spherical bore (ΔA_{2s}) and tolerance of position of bolt hole (X)

Housing No.	ΔA_{2s}	X
FL204~FL210	± 0.5	0.7
FL211	± 0.8	1

Variations of tolerance of bolt hole diameter (ΔN_v)

Housing No.	ΔN_v
FL204~FL211	± 0.2

Shaft Dia. mm inch	<i>d</i>	Dimensions inch mm										Bolt Size inch mm	Unit No.	Bearing No.	Unit No.	Bearing No.	Housing No.	Basic Load Ratings kN		Factor f_0	Mass kg			
		<i>H</i>	<i>L</i>	<i>A</i>	<i>J</i>	<i>N</i>	<i>A</i> ₁	<i>A</i> ₂	<i>A</i> ₀	<i>B</i>	<i>B</i> ₁							SBFL-RKP8 <i>S</i>	SAFL-FP9 <i>S</i>		<i>C_r</i>	<i>C_{0r}</i>	SBFL-RKP8	SAFL-FP9
20	³ / ₄	4 ⁷ / ₁₆	2 ³ / ₈	1	3 ³⁵ / ₆₄	¹⁵ / ₃₂	⁷ / ₁₆	¹⁹ / ₃₂	1 ¹⁷ / ₃₂	0.984	1.220	0.276	0.295	³ / ₈	SBFL204-12RKP8	SB204-12RKP8	SAFL204-12FP9	SA204-12FP9	FL204	12.8	6.65	13.2	0.44	0.48
	113	60	25.5	90	12	11	15	38.5	25	31	7	7.5	M10	SBFL204RKP8	SB204RKP8	SAFL204FP9	SA204FP9							
25	⁷ / ₈	5 ¹ / ₈	2 ¹¹ / ₁₆	1 ¹ / ₁₆	3 ⁵⁷ / ₆₄	⁵ / ₈	¹ / ₂	⁵ / ₈	1 ¹⁸ / ₃₂	1.063	1.220	0.295	0.295	¹ / ₂	SBFL205-14RKP8	SB205-14RKP8	SAFL205-14FP9	SA205-14FP9	FL205	14.0	7.85	13.9	0.62	0.67
	¹⁵ / ₁₆ 1	130	68	27	99	16	13	16	39.5	27	31	7.5	7.5	M14	SBFL205-15RKP8	SB205-15RKP8	SAFL205-15FP9	SA205-15FP9						
30	¹ / ₈	5 ¹³ / ₁₆	3 ⁵ / ₃₂	1 ⁷ / ₃₂	4 ³⁹ / ₆₄	⁵ / ₈	¹ / ₂	⁴⁵ / ₆₄	1 ²⁴ / ₃₂	1.181	1.906	0.315	0.354	¹ / ₂	SBFL206-18RKP8	SB206-18RKP8	SAFL206-18FP9	SA206-18FP9	FL206	19.5	11.3	13.9	0.88	0.95
	¹ / ₁₆ ¹ / ₄	148	80	31	117	16	13	18	44.7	30	35.7	8	9	M14	SBFL206-19RKP8	SB206-19RKP8	SAFL206-19FP9	SA206-19FP9						
35	¹ / ₄	6 ¹¹ / ₃₂	3 ¹⁷ / ₃₂	1 ¹¹ / ₃₂	5 ¹ / ₈	⁵ / ₈	⁹ / ₁₆	³ / ₄	1 ²⁹ / ₃₂	1.260	1.531	0.335	0.374	¹ / ₂	SBFL207-20RKP8	SB207-20RKP8	SAFL207-20FP9	SA207-20FP9	FL207	25.7	15.4	13.9	1.14	1.29
	¹ / ₁₆ ¹ / ₈ ¹ / ₄ ³ / ₈ ¹ / ₂	161	90	34	130	16	14	19	48.4	32	38.9	8.5	9.5	M14	SBFL207-22RKP8	SB207-22RKP8	SAFL207-22FP9	SA207-22FP9						
40	¹ / ₂	6 ⁷ / ₈	3 ¹⁵ / ₁₆	1 ¹³ / ₃₂	5 ⁴³ / ₆₄	⁵ / ₈	⁹ / ₁₆	⁵³ / ₆₄	2 ⁴ / ₃₂	1.339	1.720	0.354	0.433	¹ / ₂	SBFL208-24RKP8	SB208-24RKP8	SAFL208-24FP9	SA208-24FP9	FL208	29.1	17.8	14.0	1.56	1.71
	⁹ / ₁₆	175	100	36	144	16	14	21	53.7	34	43.7	9	11	M14	SBFL208RKP8	SB208RKP8	SAFL208-25FP9	SA208-25FP9						
45	¹ / ₈	7 ¹³ / ₃₂	4 ¹ / ₄	1 ¹ / ₂	5 ⁵³ / ₆₄	³ / ₄	¹⁹ / ₃₂	⁵⁵ / ₆₄	2 ⁵ / ₃₂	—	1.720	—	0.433	⁵ / ₈	—	—	SAFL209-26FP9	SA209-26FP9	FL209	34.1	21.3	14.0	—	2.04
	¹ / ₁₆ ¹ / ₈ ¹ / ₄	188	108	38	148	19	15	22	54.7	—	43.7	—	11	M16	—	—	SAFL209-27FP9	SA209-27FP9						
50	¹ / ₈	7 ³ / ₄	4 ¹⁷ / ₃₂	1 ⁹ / ₁₆	6 ³ / ₁₆	³ / ₄	¹⁹ / ₃₂	⁵⁵ / ₆₄	2 ⁵ / ₃₂	—	1.720	—	0.433	⁵ / ₈	—	—	SAFL210-30FP9	SA210-30FP9	FL210	35.1	23.3	14.4	—	2.25
	¹ / ₁₆ ¹ / ₈	197	115	40	157	19	15	22	54.7	—	43.7	—	11	M16	—	—	SAFL210-31FP9	SA210-31FP9						
55	2	8 ¹³ / ₁₆	5 ¹ / ₈	1 ¹¹ / ₁₆	7 ¹ / ₄	³ / ₄	²³ / ₃₂	⁶³ / ₆₄	2 ¹³ / ₃₂	—	1.906	—	0.472	⁵ / ₈	—	—	SAFL211-32FP9	SA211-32FP9	FL211	43.4	29.4	14.4	—	3.39
	¹ / ₈ ¹ / ₄ ³ / ₁₆	224	130	43	184	19	18	25	61.4	—	48.4	—	12	M16	—	—	SAFL211-34FP9	SA211-34FP9						

Remarks 1. In Part No. of unit and units with covers, fitting codes follow bore diameter numbers. (See Table 10.5 in P.62.)
2. Part No. of applicable grease fittings are shown below.
A-1/4-28UNF 204~210
A-R1/8..... 211

3. For the dimensions and forms of applicable bearings, see the dimensional tables of ball bearing for unit.
4. Housings of nodular graphite cast iron are also available.

SBTFD-H4RKP8
Cylindrical bore
(with set screws)
 d 12 ~ 35 mm

SATFD-FH4P9
Cylindrical bore
(with eccentric locking collar)



SBTFD-H4RKP8



SATFD-FH4P9

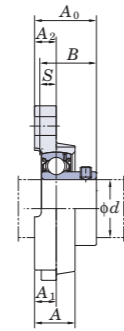

SBTFD-H4RKP8

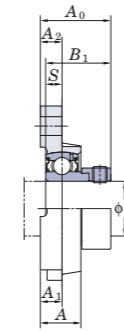
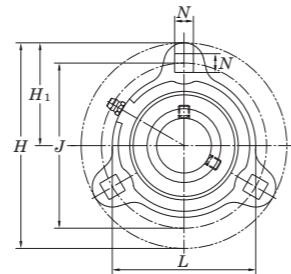

SATFD-FH4P9

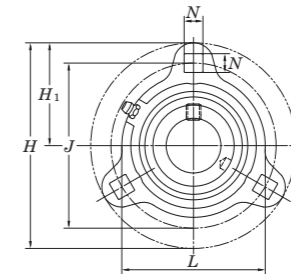

Shaft Dia. mm	inch	Dimensions													Bolt Size inch	Unit No.	Bearing No.	Unit No.	Bearing No.	Housing No.	Basic Load Ratings kN		Factor f_0	Mass kg		
		H	L	A	J	N	H_1	SBTFD A_0	SATFD A_0	A_1	A_2	B	B_1	SBTFD S							SATFD S	C_r		C_{0r}	SBTFD	SATFD
12	1/2	3 3/16	2 3/32	11/16	2 1/2	9/32	1 19/32	1	1 1/4	3/8	3/8	0.866	1.126	0.236	0.256	1/4	SBTFD201H4RKP8 SBTFD201-8H4RKP8 SBTFD202H4RKP8 SBTFD202-10H4RKP8 SBTFD203H4RKP8	SB201RKP8 SB201-8RKP8 SB202RKP8 SB202-10RKP8 SB203RKP8	SATFD201FH4P9 SATFD201-8FH4P9 SATFD202FH4P9 SATFD202-10FH4P9 SATFD203FH4P9	SA201FP9 SA201-8FP9 SA202FP9 SA202-10FP9 SA203FP9	TFD203H4	9.55	4.80	13.2	0.23	0.26
15	5/8	3 9/16	2 3/8	25/32	2 13/16	11/32	1 25/32	1 1/8	1 11/32	27/64	27/64	0.984	1.220	0.276	0.295	5/16	SBTFD204-12H4RKP8 SBTFD204H4RKP8	SB204-12RKP8 SB204RKP8	SATFD204-12FH4P9 SATFD204FH4P9	SA204-12FP9 SA204FP9	TFD204H4	12.8	6.65	13.2	0.30	0.34
20	3/4	3 3/4	2 5/8	25/32	3	11/32	1 7/8	1 3/16	1 11/32	27/64	27/64	1.063	1.220	0.295	0.295	5/16	SBTFD205-14H4RKP8 SBTFD205-15H4RKP8 SBTFD205H4RKP8 SBTFD205-16H4RKP8	SB205-14RKP8 SB205-15RKP8 SB205RKP8 SB205-16RKP8	SATFD205-14FH4P9 SATFD205-15FH4P9 SATFD205FH4P9 SATFD205-16FH4P9	SA205-14FP9 SA205-15FP9 SA205FP9 SA205-16FP9	TFD205H4	14.0	7.85	13.9	0.35	0.39
25	1	4 7/16	3 3/32	7/8	3 9/16	13/32	2 7/32	1 11/32	1 17/32	15/32	15/32	1.181	1.406	0.315	0.354	3/8	SBTFD206-18H4RKP8 SBTFD206H4RKP8 SBTFD206-19H4RKP8 SBTFD206-20H4RKP8 SBTFD207-20H4RKP8	SB206-18RKP8 SB206RKP8 SB206-19RKP8 SB206-20RKP8 SB207-20RKP8	SATFD206-18FH4P9 SATFD206FH4P9 SATFD206-19FH4P9 SATFD206-20FH4P9 SATFD207-20FH4P9	SA206-18FP9 SA206FP9 SA206-19FP9 SA206-20FP9 SA207-20FP9	TFD206H4	19.5	11.3	13.9	0.54	0.61
30	1 1/8	4 13/16	3 1/2	15/16	3 15/16	13/32	2 13/32	1 7/16	1 21/32	1/2	1/2	1.260	1.531	0.335	0.374	3/8	SBTFD207-22H4RKP8 SBTFD207H4RKP8 SBTFD207-23H4RKP8	SB207-22RKP8 SB207RKP8 SB207-23RKP8	SATFD207-21FH4P9 SATFD207-22FH4P9 SATFD207FH4P9 SATFD207-23FH4P9	SA207-21FP9 SA207-22FP9 SA207FP9 SA207-23FP9	TFD207H4	25.7	15.4	13.9	0.67	0.82

Remarks 1. In Part No. of unit and units with covers, fitting codes follow bore diameter codes. (See Table 10.5 in P.62.)
2. Part No. of applicable grease fitting is A-1/4-28UNF.
3. For the dimensions and forms of applicable bearings, see the dimensional tables of ball bearing for unit.

BLF
Cylindrical bore
(with set screws)
 d 12 ~ 35 mm

ALF
Cylindrical bore
(with eccentric locking collar)

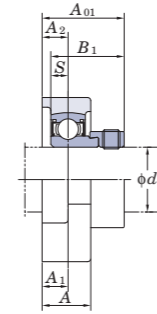
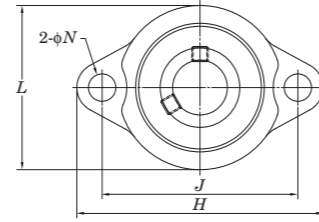
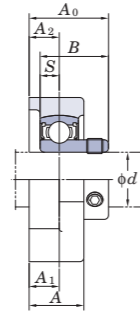

ALF

Shaft Dia. mm inch	Dimensions inch mm										Bolt Size inch mm	Unit No.	Bearing No.	Unit No.	Bearing No.	Housing No.	Basic Load Ratings kN		Factor f_0	Mass kg				
	d	H	L	A	J	N	A_1	A_2	S	BLF A_0 B							ALF A_{01} B_1	C_r		C_{0r}	BLF	ALF		
12 1/2	3 3/16	2 1/16	23/32	2 1/2	5/16	3/8	3/8	0.236	1	0.866	1 1/4	1.122	1/4	BLF201 BLF201-8 BLF202 BLF202-10 BLF203	SB201 SB201-8 SB202 SB202-10 SB203		ALF201 ALF201-8 ALF202 ALF202-10 ALF203	SA201 SA201-8 SA202 SA202-10 SA203	LF203	9.55	4.80	13.2	0.25	0.28
15 5/8	3 17/32	2 3/8	25/32	2 13/16	5/16	7/16	7/16	0.276	1 5/32	0.984	1 5/16	1.161	5/16	BLF204-12 BLF204	SB204-12 SB204		ALF204-12 ALF204	SA204-12 SA204	LF204	12.8	6.65	13.2	0.33	0.33
20 3/4	3 3/4	2 17/32	25/32	2 63/64	5/16	7/16	7/16	0.295	1 3/16	1.063	1 11/32	1.201	5/16	BLF205-14 BLF205-15 BLF205 BLF205-16	SB205-14 SB205-15 SB205 SB205-16		ALF205-14 ALF205-15 ALF205 ALF205-16	SA205-14 SA205-15 SA205 SA205-16	LF205	14.0	7.85	13.9	0.38	0.42
25 7/8	4 7/16	3	7/8	3 9/16	15/32	15/32	15/32	0.315	1 11/32	1.181	1 1/2	1.335	3/8	BLF206-18 BLF206 BLF206-19 BLF206-20 BLF207-20	SB206-18 SB206 SB206-19 SB206-20 SB207-20		ALF206-18 ALF206 ALF206-19 ALF206-20	SA206-18 SA206 SA206-19 SA206-20	LF206	19.5	11.3	13.9	0.57	0.60
30 1 1/8	4 13/16	3 1/2	15/16	3 15/16	15/32	1/2	33/64	0.335	1 7/16	1.260	1 5/8	1.437	3/8	BLF207-22 BLF207 BLF207-23	SB207-22 SB207 SB207-23		ALF207-20 ALF207-21 ALF207-22 ALF207	SA207-20 SA207-21 SA207-22 SA207	LF207	25.7	15.4	13.9	0.77	0.85
35 1 1/4	1 5/16	1 3/8	1 7/16																					

Remarks 1. In Part No. of unit and units with covers, fitting codes follow bore diameter codes. (See Table 10.5 in P.62.)
2. Allowable load to housing in radial direction is approximately half of basic load rating of bearing, C_r (when safety factor is 4).
3. For the dimensions and forms of applicable bearings, see the dimensional tables of ball bearing for unit.

Variations of tolerance of distance from mounting surface to center of spherical bore (ΔA_{2s}) and variations of tolerance of distance between centers of bolt holes (ΔJ_s)

Housing No.	ΔA_{2s}	ΔJ_s
LF203~LF207	± 0.5	± 0.7

Variations of tolerance of bolt hole diameter (ΔN_s)

Housing No.	ΔN_s
LF203~LF207	± 0.2

UFL
Cylindrical bore (with set screws)
 $d \sim 30 \text{ mm}$

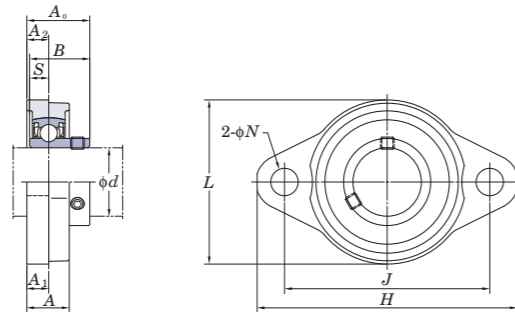

With Through Type Cover With One Side Sealed Cover

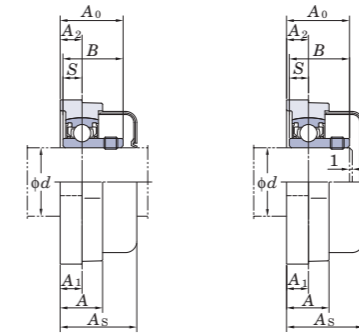

Variations of tolerance of distance from mounting surface to center of spherical bore (ΔA_{2s}) and variations of tolerance of distance between centers of bolt holes (ΔJ_s)

Housing No.	ΔA_{2s}	ΔJ_s
FL08	± 0.5	± 0.3
FL000~FL006		

Variations of tolerance of bolt hole diameter (ΔN_s)

Housing No.	ΔN_s
FL08	± 0.2
FL000~FL006	

Shaft Dia. mm d	Dimensions inch mm										Bolt Size inch mm	Standard			Mass kg	Basic Load Ratings kN		Factor f_0	With Rubber Coated Cover			
	H	L	A	J	N	A_1	A_2	A_0	B	S		Unit No.	Housing No.	Bearing No.		C_r	C_{0r}		Unit No. Open Type	Unit No. Closed Type	Dimension mm inch A_s	Mass kg
8	1 7/8 48	1 1/16 27	1 1/32 8.5	1 29/64 37	3/16 4.8	5/32 4	5/32 4	1/2 12.5	0.472 12	0.1378 3.5	No.8 M4	UFL08	FL08	SU08								
10	2 3/8 60	1 13/32 36	1 5/32 15	1 49/64 45	9/32 7	1/4 6	15/64 6	5/8 16	0.591 15	0.197 5	1/4 M6	UFL000	FL000	SU000								
12	2 15/32 63	1 1/2 38	1 5/32 12	1 57/64 48	9/32 7	1/4 6	15/64 6	5/8 16	0.591 15	0.197 5	1/4 M6	UFL001	FL001	SU001								
15	2 5/8 67	1 21/32 42	1/2 13	2 3/32 53	9/32 7	1/4 6.5	1/4 6.5	1 1/16 17.5	0.650 16.5	0.217 5.5	1/4 M6	UFL002	FL002	SU002								
17	2 25/32 71	1 13/16 46	9/16 14	2 13/64 56	9/32 7	9/32 7	9/32 7	23/32 18.5	0.689 17.5	0.236 6	1/4 M6	UFL003	FL003	SU003								
20	3 17/32 90	2 5/32 55	5/8 16	2 51/64 71	13/32 10	5/16 8	5/16 8	7/8 22	0.827 21	0.276 7	5/16 M8	UFL004	FL004	SU004								
25	3 3/4 95	2 3/8 60	5/8 16	2 61/64 75	13/32 10	5/16 8	5/16 8	29/32 23	0.866 22	0.276 7	5/16 M8	UFL005	FL005	SU005								
30	4 13/32 112	2 3/4 70	23/32 18	3 11/32 85	1/2 13	1 1/32 9	23/64 9	1 1/32 26	0.965 24.5	0.295 7.5	3/8 M10	UFL006	FL006	SU006								

Remarks 1. In Part No. of unit and units with covers, fitting codes follow bore diameter codes. (See Table 10.5 in P.62.)
2. For the dimensions and forms of applicable bearings, see the dimensional tables of ball bearing for unit.

UCSFL-H1S6
Cylindrical bore (with set screws)
d 12 ~ 50 mm

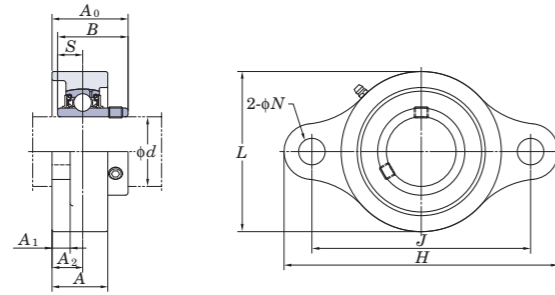

With Pressed Stainless Steel Cover

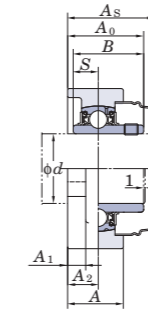

Variations of tolerance of distance from mounting surface to center of spherical bore (ΔA_{2s}) and variations of tolerance of distance between centers of bolt holes (ΔJ_s)

Housing No.	ΔA_{2s}	ΔJ_s
SFL203H1~SFL210H1	± 0.5	± 0.5

Variations of tolerance of bolt hole diameter (ΔN_s)

Housing No.	ΔN_s
SFL203H1~SFL210H1	± 0.2

Shaft Dia. mm inch <i>d</i>	Dimensions inch mm										Bolt Size inch mm	Standard		Bearing No.	Mass kg	Basic Load Ratings kN <i>C_r</i> <i>C_{0r}</i>		Factor <i>f₀</i>	With Pressed Stainless Steel Cover		Dimension mm inch <i>A_s</i>	Mass kg
	<i>H</i>	<i>L</i>	<i>A</i>	<i>J</i>	<i>N</i>	<i>A₁</i>	<i>A₂</i>	<i>A₀</i>	<i>B</i>	<i>S</i>		Unit No.	Housing No.			Open Type	Closed Type					
12 1/2	3 27/32 98	2 1/16 52	1 5/16 24	3 76.5	1 5/32 12	1 3/32 10	9/16 14	1 3/16 29.9	1.079	0.453	3/8 M10	SFL203H1	UCSFL201XH1S6	UC201XS6	0.33	8.15	3.85	13.2	-	-	-	-
													UCSFL201-8XH1S6	UC201-8XS6					-	-	-	-
15 5/8	3 27/32 98	2 1/16 52	1 5/16 24	3 76.5	1 5/32 12	1 3/32 10	9/16 14	1 3/16 29.9	1.079	0.453	3/8 M10	SFL203H1	UCSFL202XH1S6	UC202XS6	0.33	8.15	3.85	13.2	-	-	-	-
													UCSFL202-10XH1S6	UC202-10XS6					-	-	-	-
17	3 27/32 98	2 1/16 52	1 5/16 24	3 76.5	1 5/32 12	1 3/32 10	9/16 14	1 3/16 29.9	1.079	0.453	3/8 M10	SFL203H1	UCSFL203XH1S6	UC203XS6	0.33	8.15	3.85	13.2	-	-	-	-
													-	-					-	-	-	-
20 3/4	4 7/16 113	2 3/8 60	1 1/32 26	3 35/64 90	1 5/32 12	1 3/32 10	1 9/32 15	1 5/16 33.3	1.220	0.500	3/8 M10	SFL204H1	UCSFL204-12H1S6	UC204-12S6	0.47	10.9	5.35	13.2	-	-	-	-
													UCSFL204H1S6	UC204S6					UCSFL204H1CS6	UCSFL204H1DS6	38	1 1/2
25 7/8	5 1/8 130	2 11/16 68	1 3/32 27.5	3 57/64 99	5/8 16	1 3/32 10	5/8 16	1 13/32 35.8	1.343	0.563	1/2 M14	SFL205H1	UCSFL205-14H1S6	UC205-14S6	0.61	11.9	6.30	13.9	-	-	-	-
													UCSFL205-15H1S6	UC205-15S6					UCSFL205H1CS6	UCSFL205H1DS6	40	1 9/16
30 1 1/8	5 13/16 148	3 5/32 80	1 7/32 117	4 39/64 116	5/8 16	1 3/32 10	45/64 18	1 19/32 40.2	1.500	0.626	1/2 M14	SFL206H1	UCSFL206-18H1S6	UC206-18S6	0.9	16.5	9.05	13.9	-	-	-	-
													UCSFL206H1S6	UC206S6					UCSFL206H1CS6	UCSFL206H1DS6	45	1 15/32
35 1 1/4	6 11/32 161	3 11/32 85	1 11/32 130	5 1/8 130	5/8 16	7/16 11	3/4 19	1 3/4 44.4	1.689	0.689	1/2 M14	SFL207H1	UCSFL207-20H1S6	UC207-20S6	1.1	21.8	12.3	13.9	-	-	-	-
													UCSFL207-21H1S6	UC207-21S6					UCSFL207H1CS6	UCSFL207H1DS6	49	1 15/16
40 1 1/2	6 7/8 175	3 11/16 94	1 13/32 144	5 43/64 144	5/8 16	1 5/32 12	53/64 21	2 1/32 51.2	1.937	0.748	1/2 M14	SFL208H1	UCSFL208-24H1S6	UC208-24S6	1.4	24.8	14.3	14.0	-	-	-	-
													UCSFL208-25H1S6	UC208-25S6					UCSFL208H1CS6	UCSFL208H1DS6	56	2 7/32
45 1 5/8	7 13/32 188	3 15/16 100	1 1/2 148	5 53/64 148	3/4 19	1/2 13	55/64 22	2 1/16 52.2	1.937	0.748	5/8 M16	SFL209H1	UCSFL209-26H1S6	UC209-26S6	1.6	27.8	16.2	14.0	-	-	-	-
													UCSFL209-27H1S6	UC209-27S6					UCSFL209H1CS6	UCSFL209H1DS6	57	2 7/32
50 1 15/16	7 3/4 197	4 3/16 106	1 9/16 157	6 3/16 157	3/4 19	1/2 13	55/64 22	2 5/32 54.6	2.031	0.748	5/8 M16	SFL210H1	UCSFL210-30H1S6	UC210-30S6	1.9	29.8	18.6	14.4	-	-	-	-
													UCSFL210-31H1S6	UC210-31S6					UCSFL210H1CS6	UCSFL210H1DS6	59	2 5/16
													UCSFL210-32H1S6	UC210-32S6								

Remarks 1. In Part No. of unit and units with covers, fitting codes follow bore diameter codes. (See Table 10.5 in P.62.)
 2. Part No. of applicable grease fitting is A-1/4-28UNFN12.
 3. For the dimensions and forms of applicable bearings, see the dimensional tables of ball bearing for unit.

UCSFL-EH1S6
Cylindrical bore (with set screws)
d 12 ~ 50 mm

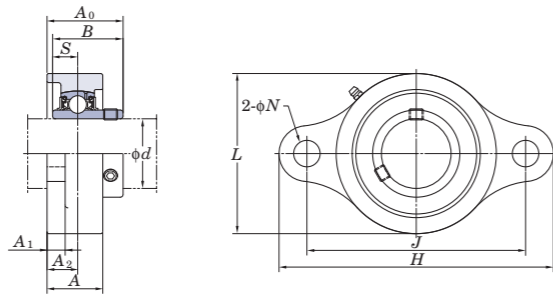

With Pressed Stainless Steel Cover

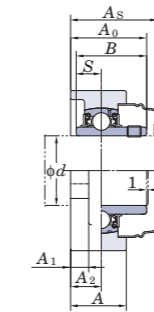

Variations of tolerance of distance from mounting surface to center of spherical bore (Δ_{A2s}) and variations of tolerance of distance between centers of bolt holes (Δ_{Jb})

Housing No.	Δ_{A2s}	Δ_{Jb}
SFL203EH1~SFL210EH1	±0.5	±0.5

Unit: mm

Variations of tolerance of bolt hole diameter (Δ_{N6})

Housing No.	Δ_{N6}
SFL203EH1~SFL210EH1	±0.2

Unit: mm

Shaft Dia. mm inch <i>d</i>	Dimensions										Bolt Size inch mm	Standard		Bearing No.	Mass kg	Basic Load Ratings kN		Factor f_0	With Pressed Stainless Steel Cover			
	<i>H</i>	<i>L</i>	<i>A</i>	<i>J</i>	<i>N</i>	<i>A</i> ₁	<i>A</i> ₂	<i>A</i> ₀	<i>B</i>	<i>S</i>		Unit No.	Housing No.			<i>C</i> _r	<i>C</i> _{0r}		Open Type	Closed Type	Dimension mm inch <i>A</i> _s	Mass kg
12 1/2											5/16	UCSFL201XEH1S6 UCSFL201-8XEH1S6	SFL203EH1					—	—	—		
15 5/8	3 27/32	2 1/16	15/16	3	25/64	13/32	9/16	1 3/16	1.079	0.453	5/16	UCSFL202XEH1S6 UCSFL202-10XEH1S6	SFL203EH1	UC201XS6 UC201-8XS6	0.33	8.15	3.85	13.2	—	—	—	
17											5/16	UCSFL203XEH1S6	SFL204EH1	UC202XS6 UC202-10XS6					—	—	—	
20 3/4	4 7/16	2 3/8	1 1/32	3 17/32	25/64	13/32	19/32	1 5/16	1.220	0.500	5/16	UCSFL204XEH1S6	SFL204EH1	UC203XS6					—	—	—	
20											5/16	UCSFL204EH1S6	SFL204EH1	UC204-12S6 UC204S6	0.47	10.9	5.35	13.2	UCSFL204EH1CS6	UCSFL204EH1DS6	38 1 1/2	0.47
25 7/8 15/16	5 1/8	2 11/16	1 3/32	3 57/64	15/32	13/32	5/8	1 13/32	1.343	0.563	3/8	UCSFL205-14EH1S6 UCSFL205-15EH1S6	SFL205EH1	UC205-14S6 UC205-15S6	0.61	11.9	6.30	13.9	—	—	—	
25											3/8	UCSFL205EH1S6	SFL205EH1	UC205S6					UCSFL205EH1CS6	UCSFL205EH1DS6	40 1 9/16	0.61
25											3/8	UCSFL205-16EH1S6 UCSFL206-18EH1S6	SFL206EH1	UC205-16S6 UC206-18S6					—	—	—	
30 1 1/8	5 13/16	3 5/32	1 7/32	4 39/64	15/32	13/32	45/64	1 19/32	1.500	0.626	3/8	UCSFL206EH1S6	SFL206EH1	UC206S6	0.9	16.5	9.05	13.9	—	—	—	
30											3/8	UCSFL206-19EH1S6 UCSFL206-20EH1S6	SFL206EH1	UC206-19S6 UC206-20S6					UCSFL206EH1CS6	UCSFL206EH1DS6	45 1 15/32	0.9
30											3/8	UCSFL206-18EH1S6	SFL206EH1	UC206-18S6					—	—	—	
35 1 1/4 1 3/8	6 11/32	3 11/32	1 11/32	5 1/8	33/64	7/16	3/4	1 3/4	1.689	0.689	7/16	UCSFL207-20EH1S6 UCSFL207-21EH1S6	SFL207EH1	UC207-20S6 UC207-21S6	1.1	21.8	12.3	13.9	—	—	—	
35											7/16	UCSFL207EH1S6	SFL207EH1	UC207S6					UCSFL207EH1CS6	UCSFL207EH1DS6	49 1 15/16	1.1
35											7/16	UCSFL207-22EH1S6 UCSFL207-23EH1S6	SFL207EH1	UC207-22S6 UC207-23S6					—	—	—	
40 1 1/2 1 9/16	6 7/8	3 11/16	1 13/32	5 21/32	33/64	15/32	53/64	2 1/32	1.937	0.748	7/16	UCSFL208-24EH1S6 UCSFL208-25EH1S6	SFL208EH1	UC208-24S6 UC208-25S6	1.4	24.8	14.3	14.0	—	—	—	
40											7/16	UCSFL208EH1S6	SFL208EH1	UC208S6					UCSFL208EH1CS6	UCSFL208EH1DS6	56 2 7/32	1.4
40											7/16	UCSFL208-24EH1S6	SFL208EH1	UC208-24S6					—	—	—	
45 1 5/8 1 11/16 1 3/4	7 13/32	3 15/16	1 1/2	5 27/32	19/32	1/2	55/64	2 1/16	1.937	0.748	1/2	UCSFL209-26EH1S6 UCSFL209-27EH1S6	SFL209EH1	UC209-26S6 UC209-27S6	1.6	27.8	16.2	14.0	—	—	—	
45											1/2	UCSFL209EH1S6	SFL209EH1	UC209S6					UCSFL209EH1CS6	UCSFL209EH1DS6	57 2 1/4	1.6
45											1/2	UCSFL209-28EH1S6 UCSFL209EH1S6	SFL209EH1	UC209-28S6 UC209S6					—	—	—	
50 1 7/8 1 15/16	7 3/4	4 3/16	1 9/16	6 3/16	19/32	1/2	55/64	2 5/32	2.031	0.748	1/2	UCSFL210-30EH1S6 UCSFL210-31EH1S6	SFL210EH1	UC210-30S6 UC210-31S6	1.9	29.8	18.6	14.4	—	—	—	
50											1/2	UCSFL210EH1S6	SFL210EH1	UC210S6					UCSFL210EH1CS6	UCSFL210EH1DS6	59 2 5/16	1.9
50											1/2	UCSFL210-32EH1S6	SFL210EH1	UC210-32S6					—	—	—	

Remarks 1. In Part No. of unit and units with covers, fitting codes follow bore diameter codes. (See Table 10.5 in P.62.)
2. Part No. of applicable grease fitting is A-1/4-28UNFN12.
3. For the dimensions and forms of applicable bearings, see the dimensional tables of ball bearing for unit.

USFL-S6
Cylindrical bore (with set screws)
 d 10 ~ 30 mm

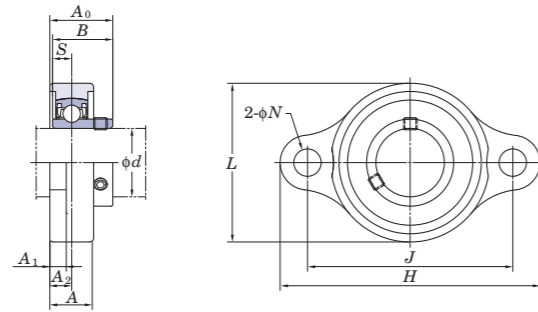

With Through Type Cover With One Side Sealed Cover

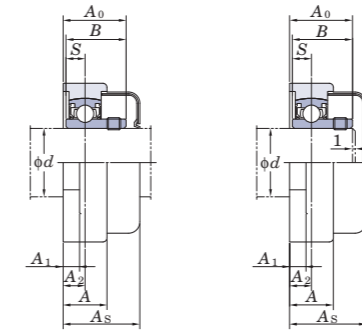

Variations of tolerance of distance from mounting surface to center of spherical bore (ΔA_{2s}) and variations of tolerance of distance between centers of bolt holes (ΔJ_s)

Housing No.	ΔA_{2s}	ΔJ_s
SFL000~SFL006	± 0.5	± 0.3

Variations of tolerance of bolt hole diameter (ΔN_s)

Housing No.	ΔN_s
SFL000~SFL006	± 0.2

Shaft Dia. mm d	Dimensions inch mm										Bolt Size inch mm	Standard			Mass kg	Basic Load Ratings kN		Factor f_0	With Rubber Coated Cover				
	H	L	A	J	N	A_1	A_2	A_0	B	S		Unit No.	Housing No.	Bearing No.		Unit No. Open Type	Unit No. Closed Type		Dimension mm inch A_s	Mass kg			
10	2 3/8	1 11/32	15/32	1 49/64	9/32	3/16	15/64	5/8	0.591	0.197	1/4	USFL000S6	SFL000	SU000S6	0.076	3.9	1.55	12.3	USFL000CS6	USFL000DS6	20.5	13/16	0.08
	60	34	12	45	7	5	6	16	15	5	M6												
12	2 15/32	1 13/32	15/32	1 57/64	9/32	3/16	15/64	5/8	0.591	0.197	1/4	USFL001S6	SFL001	SU001S6	0.080	4.3	1.9	13.2	USFL001CS6	USFL001DS6	20.5	13/16	0.08
	63	36	12	48	7	5	6	16	15	5	M6												
15	2 5/8	1 5/8	1/2	2 3/32	9/32	1/4	1/4	11/16	0.650	0.217	1/4	USFL002S6	SFL002	SU002S6	0.1	4.7	2.25	13.9	USFL002CS6	USFL002DS6	22	7/8	0.1
	67	41	13	53	7	6	6.5	17.5	16.5	5.5	M6												
17	2 25/32	1 23/32	9/16	2 13/64	9/32	1/4	9/32	23/32	0.689	0.236	1/4	USFL003S6	SFL003	SU003S6	0.13	5.1	2.6	14.4	USFL003CS6	USFL003DS6	23.5	15/16	0.13
	71	44	14	56	7	6	7	18.5	17.5	6	M6												
20	3 19/32	2 3/32	5/8	2 51/64	13/32	1/4	5/16	7/8	0.827	0.276	5/16	USFL004S6	SFL004	SU004S6	0.21	7.9	4	13.9	USFL004CS6	USFL004DS6	27	1 1/16	0.21
	91	53	16	71	10	6	8	22	21	7	M8												
25	3 3/4	2 9/32	5/8	2 61/64	13/32	1/4	5/16	29/32	0.866	0.276	5/16	USFL005S6	SFL005	SU005S6	0.23	8.5	4.65	14.5	USFL005CS6	USFL005DS6	28	1 3/32	0.23
	95	58	16	75	10	6	8	23	22	7	M8												
30	4 11/32	2 19/32	23/32	3 11/32	1/2	9/32	23/64	1 1/32	0.965	0.295	3/8	USFL006S6	SFL006	SU006S6	0.33	11.2	6.6	14.7	USFL006CS6	USFL006DS6	31	1 7/32	0.33
	110	66	18	85	13	7	9	26	24.5	7.5	M10												

Remarks 1. In Part No. of unit and units with covers, fitting codes follow bore diameter codes. (See Table 10.5 in P.62.)
2. For the dimensions and forms of applicable bearings, see the dimensional tables of ball bearing for unit.

UCVFL-S6
Cylindrical bore (with set screws)
 d 20 ~ 40 mm

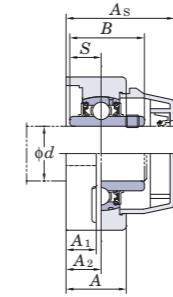
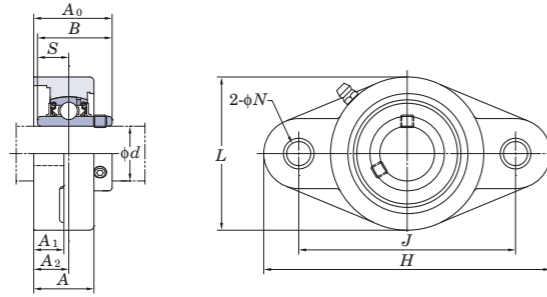

Variations of tolerance of distance from mounting surface to center of spherical bore (ΔA_{2s}) and tolerance of position of bolt hole (X)

Housing No.	ΔA_{2s}	X
VFL204~VFL208	± 0.5	0.7

Unit: mm

Shaft Dia. mm inch d	Dimensions inch mm										Bolt Size inch mm	Standard			Mass kg	Basic Load Ratings kN		Factor f_0	With Plastic Cover		Dimension mm inch		Mass kg
	H	L	A	J	N	A_1	A_2	A_0	B	S		Unit No.	Housing No.	Bearing No.		C_r	C_{0r}		Open Type	Closed Type	A_s		
20 $\frac{3}{4}$	$4\frac{7}{16}$	$2\frac{9}{16}$	$1\frac{1}{32}$	$3\frac{35}{64}$	$\frac{7}{16}$	$\frac{17}{32}$	$\frac{19}{32}$	$1\frac{5}{16}$	1.220	0.500	$\frac{3}{8}$	VFL204	UC204-12S6	10.9	5.35	13.2	UCVFL204-12CS6	UCVFL204-12DS6	46.5	$1\frac{27}{32}$	0.26		
	113	65	26.5	90	11	13.4	15	33.3	31	12.7	M8		UC204S6				UCVFL204CS6	UCVFL204DS6					
25 $\frac{7}{8}$ $\frac{15}{16}$	$5\frac{5}{32}$	$2\frac{3}{4}$	$1\frac{3}{32}$	$3\frac{57}{64}$	$\frac{7}{16}$	$\frac{17}{32}$	$\frac{5}{8}$	$1\frac{13}{32}$	1.343	0.563	$\frac{3}{8}$	VFL205	UC205-14S6	11.9	6.3	13.9	UCVFL205-14CS6	UCVFL205-14DS6	50.2	$1\frac{31}{32}$	0.36		
	131	70	27.5	99	11	13.8	16	35.8	34.1	14.3	M8		UC205S6				UCVFL205CS6	UCVFL205DS6					
30 $1\frac{1}{8}$ $1\frac{3}{16}$ $1\frac{1}{4}$	$5\frac{13}{16}$	$3\frac{5}{32}$	$1\frac{3}{16}$	$4\frac{39}{64}$	$\frac{7}{16}$	$\frac{9}{16}$	$\frac{45}{64}$	$1\frac{19}{32}$	1.500	0.626	$\frac{3}{8}$	VFL206	UC206-18S6	16.5	9.05	13.9	UCVFL206-18CS6	UCVFL206-18DS6	57.5	$2\frac{1}{4}$	0.50		
	148	80	30.5	117	11	14.3	18	40.2	38.1	15.9	M8		UC206S6				UCVFL206CS6	UCVFL206DS6					
35 $1\frac{5}{16}$ $1\frac{3}{8}$ $1\frac{7}{16}$	$6\frac{15}{32}$	$3\frac{17}{32}$	$1\frac{1}{4}$	$5\frac{1}{8}$	$\frac{33}{64}$	$\frac{5}{8}$	$\frac{3}{4}$	$1\frac{3}{4}$	1.689	0.689	$\frac{7}{16}$	VFL207	UC207-20S6	21.8	12.3	13.9	UCVFL207-20CS6	UCVFL207-20DS6	61.2	$2\frac{13}{32}$	0.75		
	164	90	32	130	13	15.5	19	44.4	42.9	17.5	M10		UC207S6				UCVFL207CS6	UCVFL207DS6					
40 $1\frac{1}{2}$ $1\frac{9}{16}$	$6\frac{15}{16}$	$3\frac{15}{16}$	$1\frac{11}{32}$	$5\frac{43}{64}$	$\frac{35}{64}$	$\frac{21}{32}$	$\frac{53}{64}$	$2\frac{1}{32}$	1.937	0.748	$\frac{1}{2}$	VFL208	UC208-24S6	24.8	13.3	14.0	UCVFL208-24CS6	UCVFL208-24DS6	69.2	$2\frac{23}{32}$	0.95		
	176	100	34.5	144	14	16.5	21	51.2	49.2	19	M12		UC208S6				UCVFL208CS6	UCVFL208DS6					

Remarks 1. In Part No. of unit and units with covers, fitting codes follow bore diameter numbers. (See Table 10.5 in P.62.)
2. Part No. of the applicable grease fitting is A-1/4-28UNFN12.
3. For the dimensions and forms of applicable bearings, see the dimensional tables of ball bearing for unit.

UCVFL-ES7
Cylindrical bore (with set screws)
 d 20 ~ 40 mm

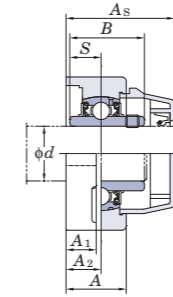
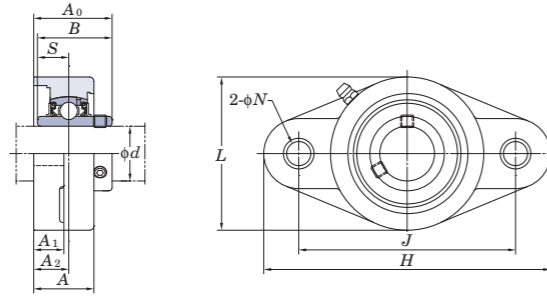

Variations of tolerance of distance from mounting surface to center of spherical bore (ΔA_{2s}) and tolerance of position of bolt hole (X)

Housing No.	ΔA_{2s}	X
VFL204E~VFL208E	± 0.5	0.7

Unit: mm

Shaft Dia. mm inch d	Dimensions inch mm											Bolt Size inch mm	Standard			Mass kg	Basic Load Ratings kN		Factor f_0	With Plastic Cover		Dimension		Mass kg
	H	L	A	J	N	A_1	A_2	A_0	B	S	Unit No.		Housing No.	Bearing No.	C_r		C_{0r}	Open Type		Closed Type	mm	inch		
20 $\frac{3}{4}$	$4\frac{7}{16}$	$2\frac{9}{16}$	$1\frac{1}{32}$	$3\frac{35}{64}$	$\frac{7}{16}$	$\frac{17}{32}$	$\frac{19}{32}$	$1\frac{5}{16}$	1.220	0.500	$\frac{3}{8}$	UCVFL204-12ES7 UCVFL204ES7	VFL204E	UC204-12S7 UC204S7	0.25	12.8	6.65	13.2	UCVFL204-12ECS7	UCVFL204-12EDS7	46.5	$1\frac{27}{32}$	0.26	
	113	65	26.5	90	11	13.4	15	33.3	31	12.7	M8													
25 $\frac{7}{8}$ $\frac{15}{16}$	$5\frac{5}{32}$	$2\frac{3}{4}$	$1\frac{3}{32}$	$3\frac{57}{64}$	$\frac{7}{16}$	$\frac{17}{32}$	$\frac{5}{8}$	$1\frac{13}{32}$	1.343	0.563	$\frac{7}{16}$	UCVFL205-14ES7 UCVFL205-15ES7 UCVFL205ES7	VFL205E	UC205-14S7 UC205-15S7 UC205S7	0.35	14.0	7.85	13.9	UCVFL205-14ECS7	UCVFL205-14EDS7	50.2	$1\frac{31}{32}$	0.36	
	131	70	27.5	99	11	13.8	16	35.8	34.1	14.3	M10													
30 $1\frac{1}{8}$ $1\frac{3}{16}$ $1\frac{1}{4}$	$5\frac{13}{16}$	$3\frac{5}{32}$	$1\frac{3}{16}$	$4\frac{39}{64}$	$\frac{7}{16}$	$\frac{9}{16}$	$\frac{45}{64}$	$1\frac{19}{32}$	1.500	0.626	$\frac{7}{16}$	UCVFL206-18ES7 UCVFL206ES7	VFL206E	UC206-18S7 UC206S7	0.49	19.5	11.3	13.9	UCVFL206-18ECS7	UCVFL206-18EDS7	57.5	$2\frac{1}{4}$	0.50	
	148	80	30.5	117	11	14.3	18	40.2	38.1	15.9	M10													
35 $1\frac{1}{4}$ $1\frac{5}{16}$ $1\frac{3}{8}$	$6\frac{15}{32}$	$3\frac{17}{32}$	$1\frac{1}{4}$	$5\frac{1}{8}$	$\frac{33}{64}$	$\frac{5}{8}$	$\frac{3}{4}$	$1\frac{3}{4}$	1.689	0.689	$\frac{1}{2}$	UCVFL207-20ES7 UCVFL207-21ES7	VFL207E	UC207-20S7 UC207-21S7	0.73	25.7	15.4	13.9	UCVFL207-20ECS7	UCVFL207-20EDS7	61.2	$2\frac{13}{32}$	0.75	
	164	90	32	130	13	15.5	19	44.4	42.9	17.5	M12													
40 $1\frac{1}{2}$ $1\frac{9}{16}$	$6\frac{15}{16}$	$3\frac{15}{16}$	$1\frac{11}{32}$	$5\frac{43}{64}$	$\frac{35}{64}$	$\frac{21}{32}$	$\frac{53}{64}$	$2\frac{1}{32}$	1.937	0.748	$\frac{1}{2}$	UCVFL208-24ES7 UCVFL208-25ES7	VFL208E	UC208-24S7 UC208-25S7	0.92	29.1	17.8	14.0	UCVFL208-24ECS7	UCVFL208-24EDS7	69.2	$2\frac{23}{32}$	0.95	
	176	100	34.5	144	14	16.5	21	51.2	49.2	19	M12													

Remarks 1. In Part No. of unit and units with covers, fitting codes follow bore diameter numbers. (See Table 10.5 in P.62.)
2. Part No. of the applicable grease fitting is A-1/4-28UNFN12.
3. For the dimensions and forms of applicable bearings, see the dimensional tables of ball bearing for unit.

UCVFB-ES7
Cylindrical bore (with set screws)
 d 20 ~ 35 mm

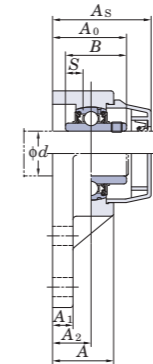
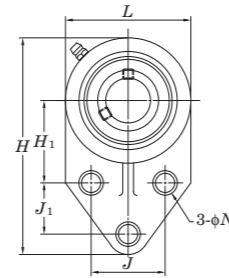
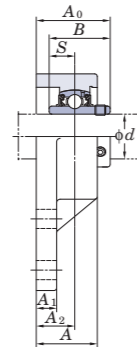

Shaft Dia. mm inch d	Dimensions inch mm													Bolt Size inch mm	Unit No.	Standard Housing No.	Bearing No.	Mass kg	Basic Load Ratings kN		Factor f_0	With Plastic Cover		Dimension		Mass kg
	H	L	A	J	J_1	N	H_1	A_1	A_2	A_0	B	S	Open Type Unit No.						Closed Type Unit No.	mm A_s		inch				
20 $\frac{3}{4}$	$4\frac{1}{4}$	$2\frac{1}{2}$	1	$1\frac{1}{2}$	$\frac{7}{8}$	$\frac{27}{64}$	$1\frac{11}{16}$	$\frac{7}{16}$	$\frac{39}{64}$	$1\frac{5}{16}$	1.220	0.500	$\frac{3}{8}$	UCVFB204-12ES7 UCVFB204ES7	VFB204E	UC204-12S7 UC204S7	0.25	12.8	6.65	13.2	UCVFB204-12ECS7 UCVFB204ECS7	UCVFB204-12EDS7 UCVFB204EDS7	45.4	$1\frac{25}{32}$	0.26	
	$\frac{7}{8}$ $\frac{15}{16}$	$4\frac{3}{4}$	$2\frac{3}{4}$	$1\frac{11}{32}$	$1\frac{5}{8}$	$1\frac{1}{8}$	$\frac{27}{64}$	$1\frac{13}{16}$	$\frac{7}{16}$	$\frac{27}{32}$	$1\frac{5}{8}$	1.343	0.563	$\frac{3}{8}$	UCVFB205-14ES7 UCVFB205-15ES7 UCVFB205ES7	VFB205E	UC205-14S7 UC205-15S7 UC205S7	0.31	14.0	7.85	13.9	UCVFB205-14ECS7 UCVFB205-15ECS7 UCVFB205ECS7	UCVFB205-14EDS7 UCVFB205-15EDS7 UCVFB205EDS7	56.8	$2\frac{1}{4}$	0.32
30 1 $1\frac{1}{8}$	$5\frac{15}{32}$	$3\frac{1}{4}$	$1\frac{1}{4}$	$1\frac{7}{8}$	$1\frac{1}{4}$	$\frac{27}{64}$	$2\frac{1}{16}$	$\frac{17}{32}$	$\frac{49}{64}$	$1\frac{5}{8}$	1.500	0.626	$\frac{3}{8}$	UCVFB206-18ES7 UCVFB206ES7	VFB206E	UC206-18S7 UC206S7	0.47	19.5	11.3	13.9	UCVFB206-18ECS7 UCVFB206ECS7	UCVFB206-18EDS7 UCVFB206EDS7	59	$2\frac{5}{16}$	0.48	
	$1\frac{3}{16}$ $1\frac{1}{4}$	139	83	32	47.6	31.8	10.7	52.4	13.3	19.3	41.5	38.1	15.9	M10	UCVFB206-19ES7 UCVFB206-20ES7		UC206-19S7 UC206-20S7					UCVFB206-19ECS7 UCVFB206-20ECS7	UCVFB206-19EDS7 UCVFB206-20EDS7			
35 $1\frac{1}{4}$ $1\frac{5}{16}$ $1\frac{3}{8}$	$6\frac{3}{16}$	$3\frac{3}{4}$	$1\frac{7}{16}$	2	$1\frac{1}{4}$	$\frac{17}{32}$	$2\frac{3}{8}$	$\frac{5}{8}$	$\frac{27}{32}$	$1\frac{27}{32}$	1.689	0.689	$\frac{1}{2}$	UCVFB207-20ES7 UCVFB207-21ES7 UCVFB207-22ES7 UCVFB207ES7	VFB207E	UC207-20S7 UC207-21S7 UC207-22S7 UC207S7	0.66	25.7	15.4	13.9	UCVFB207-20ECS7 UCVFB207-21ECS7 UCVFB207-22ECS7 UCVFB207ECS7	UCVFB207-20EDS7 UCVFB207-21EDS7 UCVFB207-22EDS7 UCVFB207EDS7	65.8	$2\frac{19}{32}$	0.68	
	$1\frac{7}{16}$	157	95	36.6	50.8	31.8	13.1	60.3	16.1	21.7	47.1	42.9	17.5	M12	UCVFB207-23ES7		UC207-23S7					UCVFB207-23ECS7	UCVFB207-23EDS7			

Remarks 1. In Part No. of unit and units with covers, fitting codes follow bore diameter numbers. (See Table 10.5 in P.62.)
2. Part No. of the applicable grease fitting is A-1/4-28UNFN12.
3. For the dimensions and forms of applicable bearings, see the dimensional tables of ball bearing for unit.

UCFC
Cylindrical bore (with set screws)
d 55 ~ 100 mm

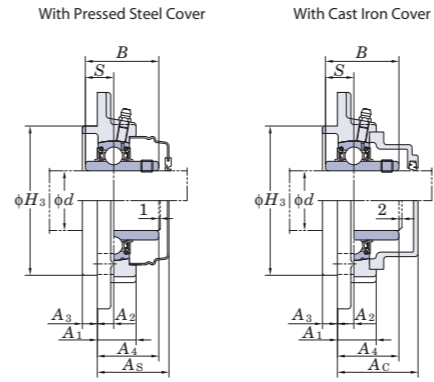
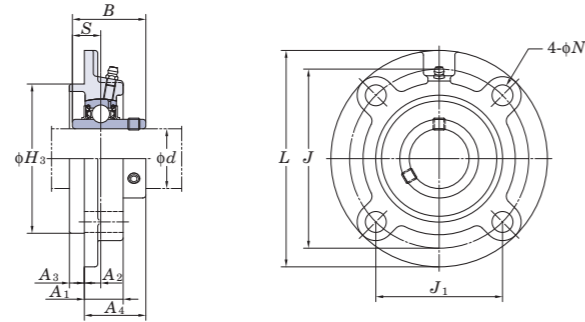

Variations of tolerance of spigot joint outside diameter (ΔH_{3s}), variations of tolerance of distance from mounting surface to center of spherical bore (ΔA_{2s}), tolerance of position of bolt hole (X), and tolerance of circumferential runout of spigot joint (Y)

Variations of tolerance of bolt hole diameter (Δh_{5s})

Housing No.		ΔH_{3s}	ΔA_{2s}	X	Y
FC204~FC206	FCX05	0 -0.046	±0.5	0.7	0.2
FC207~FC210	FCX06~FCX10	0 -0.054			
FC211~FC217	FCX11~FCX15	0 -0.063	±0.8	1	0.3
FC218	FCX16~FCX18 FCX20	0 -0.072			

Housing No.		Δh_{5s}
FC204~FC218	FCX05~FCX20	±0.2

Shaft Dia. mm inch	Dimensions inch mm												Bolt Size inch mm	Standard			Mass kg	Basic Load Ratings kN		Factor f_0	With Pressed Steel Cover			With Cast Iron Cover		
	d	L	H ₃	J	J ₁	N	A ₁	A ₂	A ₃	A ₄	B	S		Unit No.	Housing No.	Bearing No.		C _r	C _{0r}		Unit No. Open Type Closed Type	Dimension mm inch	Mass kg	Unit No. Open Type Closed Type	Dimension mm inch	Mass kg
55	2	7 9/32	4.9213	5 29/32	4 11/64	3/4	1 7/32	33/64	15/32	1 13/16	2.189	0.874	5/8	FC211	UC211-32 UC211-34 UC211	4.2	43.4	29.4	14.4	UCFC211C UCFC211D	51 2	4.2	UCFC211FC UCFC211FD	62.5 2 15/32	4.8	
	2 1/8																									
	2 3/16																									
	2 1/4																									
60	2 3/16	7 3/32	5	5 63/64	4 15/64	5/8	1 1/32	5/32	55/64	1 23/32	2.563	1.000	1/2	FCX11	UCX11 UCX11-35 UCX11-36	4.3	52.4	36.2	14.4	UCFCX11C UCFCX11D	48.5 1 29/32	4.3	-	-	-	
	2 3/8																									
	2 1/2																									
	2 7/16																									
65	2 1/4	7 11/16	5.3150	6 19/64	4 29/64	3/4	1 13/32	43/64	15/32	2 7/32	2.563	1.000	5/8	FC212	UC212-36 UC212 UC212-38 UC212-39	5.0	52.4	36.2	14.4	UCFC212C UCFC212D	61.5 2 13/32	5.0	UCFC212FC UCFC212FD	74 2 29/32	5.8	
	2 3/8																									
	2 1/2																									
	2 7/16																									
70	2 3/8	8 1/16	5.7087	6 11/16	4 47/64	3/4	1 13/32	5/8	35/64	2 3/16	2.563	1.000	5/8	FC213	UC213-40 UC213	5.6	57.2	40.1	14.4	UCFC213C UCFC213D	60.5 2 3/8	5.6	UCFC213FC UCFC213FD	73 2 7/8	6.4	
	2 3/4																									
	2 1/2																									
	2 7/16																									
75	2 3/4	8 15/32	5.9055	6 31/32	4 59/64	3/4	1 9/16	43/64	35/64	2 13/32	2.937	1.189	1/2	FCX13	UCX13-40 UCX13	5.7	62.2	44.1	14.5	UCFCX13C UCFCX13D	60.5 2 3/8	5.7	-	-	-	
	2 3/4																									
	2 3/4																									
	2 3/4																									
80	2 3/4	8 15/32	6.4567	7 31/64	5 9/32	3/4	1 13/32	35/64	25/32	2 3/16	3.063	1.331	5/8	FCX14	UCX14-44 UCX14	6.8	67.4	48.3	14.5	UCFCX14C UCFCX14D	63.5 2 1/2	7.3	-	-	-	
	2 3/4																									
	2 3/4																									
	2 3/4																									
85	2 3/4	8 15/32	6.2992	7 1/4	5 1/8	3/4	1 9/16	45/64	5/8	2 15/32	3.063	1.331	5/8	FC215	UC215-47 UC215 UC215-48	7.2	67.4	48.3	14.5	UCFC215C UCFC215D	67.5 2 21/32	7.2	UCFC215FC UCFC215FD	80 3 5/32	8.2	
	2 3/4																									
	2 3/4																									
	2 3/4																									
90	2 3/4	8 3/4	6.4567	7 31/64	5 9/32	3/4	1 3/8	15/32	55/64	2 13/32	3.252	1.311	5/8	FCX15	UCX15-47 UCX15 UCX15-48	8.0	72.7	53.0	14.6	UCFCX15C UCFCX15D	66.5 2 5/8	8.0	-	-	-	
	2 3/4																									
	2 3/4																									
	2 3/4																									
100	2 3/4	9 7/16	6.6929	7 7/8	5 9/16	29/32	1 31/32	45/64	5/8	2 21/32	3.252	1.311	3/4	FC216	UC216-50 UC216	8.7	72.7	53.0	14.6	UCFC216C UCFC216D	72.5 2 27/32	8.7	UCFC216FC UCFC216FD	87 3 7/16	9.9	
	2 3/4																									
	2 3/4																									
	2 3/4																									

Remarks 1. In Part No. of unit and units with covers, fitting codes follow bore diameter numbers. (See Table 10.5 in P.62).
2. Part No. of applicable grease fittings are shown below.
A-1/4-28UNF 201~210, X05~X09
A-R1/8 211~218, X10~X20

3. As for the triple seal type product (from 201 to 205 are the double seal type products), suffix code L3 (L2) follows the Part No. of unit or bearing. (Example of Part No. : UCFC206JL3, UC206L3)
4. For the dimensions and forms of applicable bearings, see the dimensional tables of ball bearing for unit.
5. Housings of nodular graphite cast iron are also available.

UCFCF
Cylindrical bore
(with set screws)
d 25 ~ 55 mm

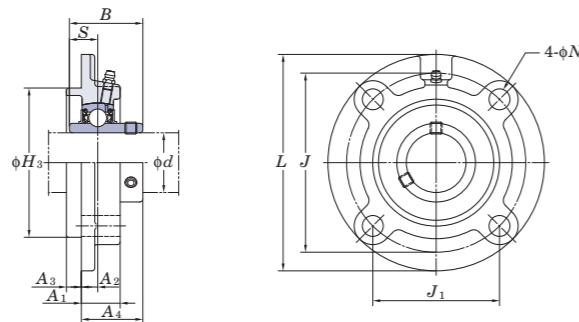

Variations of tolerance of spigot joint outside diameter (ΔH_{23s}), variations of tolerance of distance from mounting surface to center of spherical bore (ΔA_{2s}), tolerance of position of bolt hole (X), and tolerance of circumferential runout of spigot joint (Y)

Variations of tolerance of bolt hole diameter (Δh_{1s})

Housing No.	Unit: mm			
	ΔH_{23s}	ΔA_{2s}	X	Y
FCF205~FCF206	0 -0.046	±0.5	0.7	0.2
FCF207~FCF210	0 -0.054			
FCF211	0 -0.063			

Housing No.	Unit: mm
	Δh_{1s}
FCF205~FCF211	±0.2

Shaft Dia. mm inch d	Dimensions												Bolt Size inch mm	Standard			Mass kg	Basic Load Ratings kN		Factor f ₀
	L	H ₃	J	J ₁	N	A ₁	A ₂	A ₃	A ₄	B	S	Unit No.		Housing No.	Bearing No.	C _r		C _{0r}		
25 7/8 15/16 1	4 3/8	3	3 5/8	2 9/16	1 3/32	7/8	7/16	1/4	1 7/32	1.343	0.563	5/16 M8	UCFCF205-14 UCFCF205-15 UCFCF205 UCFCF205-16	FCF205	UC205-14	1.2	14.0	7.85	13.9	
	111	76.2	92.1	65.1	10.5	22.1	11.1	6.4	30.9	34.1	14.3				UC205-15 UC205 UC205-16					
30 1 1/8 1 3/16 1 1/4	5	3.375	4 1/8	2 29/32	1 5/32	7/8	5/16	1/4	1 5/32	1.500	0.626	7/16 M10	UCFCF206-18 UCFCF206 UCFCF206-19 UCFCF206-20	FCF206	UC206-18	1.8	19.5	11.3	13.9	
	127	85.725	104.8	74.1	12	20	7.5	10.5	29.7	38.1	15.9				UC206 UC206-19 UC206-20					
35 1 1/4 1 5/16 1 3/8	5 1/4	3.625	4 3/8	3 3/32	1 5/32	7/8	9/32	1/4	1 9/32	1.689	0.689	7/16 M10	UCFCF207-20 UCFCF207-21 UCFCF207-22 UCFCF207 UCFCF207-23	FCF207	UC207-20	1.8	25.7	15.4	13.9	
	133	92.075	111.1	78.6	12	22.2	7.1	11.9	32.5	42.9	17.5				UC207-21 UC207-22 UC207 UC207-23					
40 1 1/2 1 9/16	5 1/4	3.625	4 3/8	3 3/32	1 5/32	1 1/32	3/8	1/4	1 9/16	1.937	0.748	7/16 M10	UCFCF208-24 UCFCF208-25 UCFCF208	FCF208	UC208-24	2.1	29.1	17.8	14.0	
	133	92.075	111.1	78.6	12	26.1	9.5	11.9	39.7	49.2	19				UC208-25 UC208					
45 1 5/8 1 11/16 1 3/4	6 5/32	4.25	5 1/8	3 5/8	1 7/32	7/8	7/32	1/4	1 13/32	1.937	0.748	1/2 M12	UCFCF209-26 UCFCF209-27 UCFCF209-28 UCFCF209	FCF209	UC209-26	2.8	34.1	21.3	14.0	
	156	107.95	130.2	92.05	13.5	22	5.5	12	35.7	49.2	19				UC209-27 UC209-28 UC209					
50 1 7/8 1 15/16 2	6 3/8	4.5	5 3/8	3 51/64	1 7/32	1 1/16	11/32	5/8	1 5/8	2.031	0.748	1/2 M12	UCFCF210-30 UCFCF210-31 UCFCF210 UCFCF210-32	FCF210	UC210-30	3.2	35.1	23.3	14.4	
	162	114.3	136.5	96.5	13.5	27.1	8.7	15.9	41.3	51.6	19				UC210-31 UC210 UC210-32					
55 2 2 1/8 2 3/16	7 1/8	5	6	4 1/4	1 9/32	7/8	7/32	7/8	1 17/32	2.189	0.874	1/2 M14	UCFCF211-32 UCFCF211-34 UCFCF211 UCFCF211-35	FCF211	UC211-32	4.2	43.4	29.4	14.4	
	181	127	152.4	107.8	15	22.2	5.5	22.2	38.9	55.6	22.2				UC211-34 UC211 UC211-35					

- Remarks
- In Part No. of unit and units with covers, fitting codes follow bore diameter numbers. (See Table 10.5 in P.62.)
 - Part No. of applicable grease fittings are shown below.
A-1/4-28UNF 205~210
A-R1/8..... 211

- As for the triple seal type product (from 201 to 205 are the double seal type products), suffix code L3 (L2) follows the Part No. of unit or bearing. (Example of Part No.: UCFCF206JL3, UC206L3)
- For the dimensions and forms of applicable bearings, see the dimensional tables of ball bearing for unit.
- Housings of nodular graphite cast iron are also available.

4-Bolt Flange Cartridge Units

UKFC

Tapered bore (with adapter)

d₁ 70 ~ 90 mm

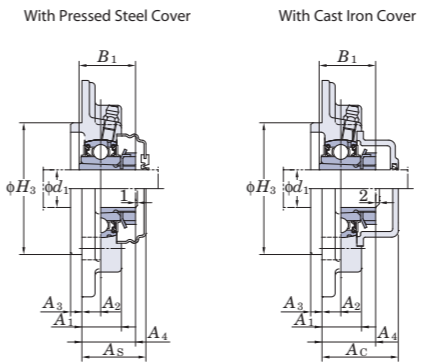
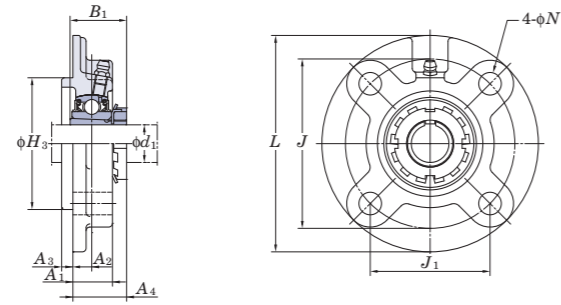

Variations of tolerance of spigot joint outside diameter (ΔH_{3s}), variations of tolerance of distance from mounting surface to center of spherical bore (ΔA_{2s}), tolerance of position of bolt hole (X), and tolerance of circumferential runout of spigot joint (Y)

Housing No.	FCX05	FCX06~FCX10	FCX11~FCX15	FCX16~FCX18	FCX20
ΔH_{3s}	0 -0.046	0 -0.054	0 -0.063	0 -0.072	0 -0.072
ΔA_{2s}	±0.5				
X	0.7				
Y	0.2				

Unit: mm

Variations of tolerance of bolt hole diameter (Δh_{6})

Housing No.	Δh_{6}
FC204~FC218 FCX05~FCX20	±0.2

Unit: mm

Shaft Dia. mm inch	Dimensions inch mm											Bolt Size inch mm	Standard			Adapter No.	Mass kg	Basic Load Ratings kN		Factor f_0	With Pressed Steel Cover				With Cast Iron Cover			
	d_1	L	H_3	J	J_1	N	A_1	A_2	A_3	A_4	B_1		Unit No.	Housing No.	Bearing No.			C_r	C_{0r}		Unit No.	Dimension mm inch	Mass kg	Unit No.	Dimension mm inch	Mass kg		
																											Open Type	Closed Type
70 2 3/4	9 7/16	6.6929	7 7/8	5 9/16	2 9/32	1 31/32	45/64	5/8	2 15/32	3 1/16	3/4	UKFC216	FC216	UK216														
	240	170	200	141.4	23	42	18	16	62.5	78	M20				72.7	53.0	14.6											
70 2 3/4	10 1/4	7.3228	8 5/8	6 3/32	2 9/32	1 13/32	25/64	63/64	1 15/16	3 1/16	3/4	UKFCX16	FCX16	UKX16														
	260	186	219	154.8	23	36	10	25	49	78	M20				84.0	61.9	14.5											
75 3	9 27/32	7.0866	8 3/16	5 51/64	2 9/32	1 25/32	45/64	45/64	3 17/32	3 7/32	3/4	UKFC217	FC217	UK217														
	250	180	208	147.1	23	45	18	18	64.5	82	M20				84.0	61.9	14.5											
75 3	10 1/4	7.3228	8 5/8	6 3/32	2 9/32	1 13/32	25/64	63/64	2 1/16	3 7/32	3/4	UKFCX17	FCX17	UKX17														
	260	186	219	154.8	23	36	10	25	52	82	M20				96.1	71.5	14.5											
80 -	10 7/16	7.4803	8 21/32	6 1/8	2 9/32	1 31/32	55/64	45/64	2 13/16	3 3/8	3/4	UKFC218	FC218	UK218														
	265	190	220	155.5	23	50	22	18	71.5	86	M20				96.1	71.5	14.5											
80 -	10 1/4	7.3228	8 5/8	6 3/32	2 9/32	1 11/16	15/32	1 7/64	2 5/32	3 3/8	3/4	UKFCX18	FCX18	UKX18														
	260	186	219	154.8	23	43	12	28	55	86	M20				109	81.9	14.4											
90 3 1/2	10 7/8	8.1102	9 3/8	6 5/8	2 9/32	2 19/32	55/64	1 7/64	2 23/32	3 13/16	3/4	UKFCX20	FCX20	UKX20														
	276	206	238	168.3	23	66	22	28	69	97	M20				133	105	14.4											

Remarks 1. In Part No. of unit and units with covers, fitting codes follow bore diameter numbers. (See Table 10.5 in P.62.)
2. Part No. of applicable grease fittings are shown below.
A-1/4-28UNF 205~210, X05~X09
A-R1/8 211~218, X10~X20

3. In Part No. of unit with adapters and bearing with adapters, Part No. of applicable adapter follow the Part No. shown in the dimensional tables. (Example of Part No.: UKFC206J + H2306X, UK206 + H2306X)
4. As for the triple seal type product (205 is the double seal type product), suffix code L3 (or L2) follows the Part No. of unit or bearing. (Example of Part No.: UKFC206JL3 + H2306X, UK206L3 + H2306X)
5. For the dimensions and forms of applicable bearings and adapters, see the dimensional tables of ball bearing for unit and adapter.
6. Housings of nodular graphite cast iron are also available.

UCSFC-H1S6
Cylindrical bore (with set screws)
d 20 ~ 40 mm

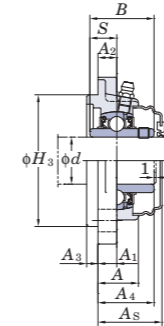
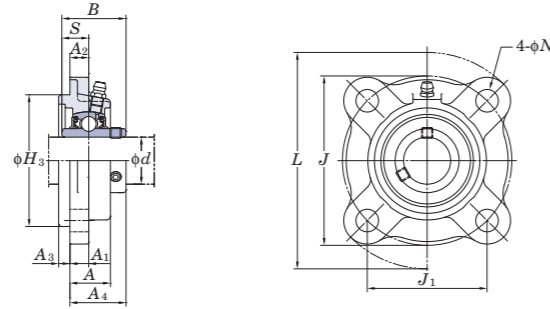

Variations of tolerance of spigot joint outside diameter (ΔH_{76})

Housing No.	ΔH_{76}	Unit: mm
SFC204H1~SFC206H1	0 -0.046	
SFC207H1~SFC208H1	0 -0.054	

Shaft Dia. mm inch <i>d</i>	Dimensions inch mm													Bolt Size inch mm	Unit No.	Standard Housing No.	Bearing No.	Mass kg	Basic Load Ratings kN		Factor <i>f</i> ₀	With Pressed Stainless Steel Cover		Dimension mm inch <i>A</i> _s	Mass kg							
	<i>L</i>	<i>H</i> ₃	<i>J</i>	<i>J</i> ₁	<i>N</i>	<i>A</i>	<i>A</i> ₁	<i>A</i> ₂	<i>A</i> ₃	<i>A</i> ₄	<i>B</i>	<i>S</i>	<i>C</i> _r						<i>C</i> _{0r}	Open Type		Closed Type										
20 3/4	3 15/16	2.4409	3 5/64	2 11/64	15/32	53/64	13/32	25/64	13/64	1 1/8	1.220	0.500	3/8	UCSFC204-12H1S6 UCSFC204H1S6	SFC204H1	UC204-12S6 UC204S6	0.5 0.5	10.9	5.35	13.2	-	-	-	-								
	100	62	78	55.1	12	21	10	10	5	28.3	31	12.7	M10								UCSFC204H1CS6	UCSFC204H1DS6	32.5	1 9/32	0.5							
25 7/8 15/16 1	4 17/32	2.7559	3 35/64	2 1/2	15/32	27/32	13/32	25/64	15/64	1 3/16	1.343	0.563	3/8	UCSFC205-14H1S6 UCSFC205-15H1S6 UCSFC205H1S6 UCSFC205-16H1S6	SFC205H1	UC205-14S6 UC205-15S6 UC205S6 UC205-16S6	0.6 0.6 0.6 0.6	11.9	6.3	13.9	-	-	-	-								
	115	70	90	63.6	12	21.5	10	10	6	29.8	34.1	14.3	M10								UCSFC205H1CS6	UCSFC205H1DS6	34.5	1 11/32	0.6							
	1 1/8	4 29/32	3.1496	3 15/16	2 25/32	15/32	29/32	13/32	25/64	5/16	1 9/32	1.500	0.626								3/8	UCSFC206-18H1S6 UCSFC206H1S6 UCSFC206-19H1S6 UCSFC206-20H1S6	SFC206H1	UC206-18S6 UC206S6 UC206-19S6 UC206-20S6	0.8 0.8 0.8 0.8	16.5	9.05	13.9	-	-	-	-
	1 3/16	125	80	100	70.7	12	23	10	10	8	32.2	38.1	15.9								M10								UCSFC206H1CS6	UCSFC206H1DS6	36.5	1 7/16
1 1/4	5 5/16	3.5433	4 21/64	3 1/16	35/64	1 1/32	15/32	7/16	5/16	1 7/16	1.689	0.689	7/16	UCSFC207-20H1S6 UCSFC207-21H1S6 UCSFC207-22H1S6 UCSFC207H1S6 UCSFC207-23H1S6	SFC207H1	UC207-20S6 UC207-21S6 UC207-22S6 UC207S6 UC207-23S6	1.1 1.1 1.1 1.1 1.1	21.8	12.3	13.9	-								-	-	-	
1 3/8	135	90	110	77.8	14	26	12	11	8	36.4	42.9	17.5	M12								UCSFC207H1CS6	UCSFC207H1DS6	41	1 5/8	1.1							
1 7/16	5 23/32	3.9370	4 23/32	3 11/32	35/64	1 1/32	15/32	7/16	25/64	1 5/8	1.937	0.748	7/16								UCSFC208-24H1S6 UCSFC208-25H1S6 UCSFC208H1S6	SFC208H1	UC208-24S6 UC208-25S6 UC208S6	1.4 1.4 1.4	24.8	14.3	14.0	-	-	-	-	
1 1/2	145	100	120	84.8	14	26	12	11	10	41.2	49.2	19	M12															UCSFC208H1CS6	UCSFC208H1DS6	45.5	1 25/32	1.4

Remarks 1. In Part No. of unit and units with covers, fitting codes follow bore diameter numbers. (See Table 10.5 in P.62.)
2. Part No. of the applicable grease fitting is A-1/4-28UNFN12.
3. For the dimensions and forms of applicable bearings, see the dimensional tables of ball bearing for unit.

SBPF
Cylindrical bore
(with set screws)
 d 12 ~ 35 mm

SAPF
Cylindrical bore
(with eccentric locking collar)



SBPF



SAPF

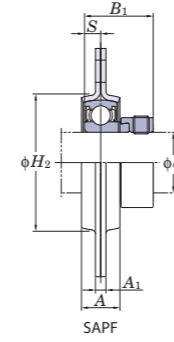
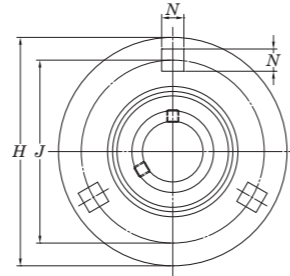
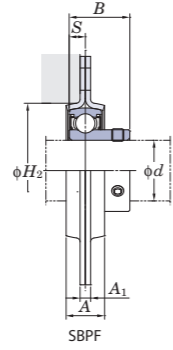

SAPF

Variations of tolerance of distance between centers of bolt holes (ΔL_s)

Housing No.	Unit: mm
PF203~PF207	± 0.4

Variations of tolerance of bolt hole diameter (ΔN_s)

Housing No.	Unit: mm
PF203~PF207	± 0.25

Shaft Dia mm inch	Dimensions inch mm								SBPF B	SAPF B ₁	Bolt Size inch mm	Unit No.	Bearing No.	Unit No.	Bearing No.	Housing No.	Basic Load Ratings kN		Factor f_0	Mass kg	
	d	H	A	A ₁	J	N	H ₂	S									C _r	C _{0r}		SBPF	SAPF
12 1/2	3 3/16	9/16	5/32	2 1/2	9/32	1 15/16	0.236	0.866	1.122	1/4	SBPF201 SBPF201-8 SBPF202 SBPF202-10 SBPF203	SB201 SB201-8 SB202 SB202-10 SB203	SAPF201 SAPF201-8 SAPF202 SAPF202-10 SAPF203	SA201 SA201-8 SA202 SA202-10 SA203	PF203	9.55	4.80	13.2	0.27	0.3	
15 5/8	3 17/32	5/8	5/32	2 13/16	23/64	2 5/32	0.276	0.984	1.161	5/16	SBPF204-12 SBPF204	SB204-12 SB204	SAPF204-12 SAPF204	SA204-12 SA204	PF204	12.8	6.65	13.2	0.33	0.33	
20 3/4	3 3/4	23/32	5/32	2 63/64	23/64	2 3/8	0.295	1.063	1.201	5/16	SBPF205-14 SBPF205-15 SBPF205 SBPF205-16	SB205-14 SB205-15 SB205 SB205-16	SAPF205-14 SAPF205-15 SAPF205 SAPF205-16	SA205-14 SA205-15 SA205 SA205-16	PF205	14.0	7.85	13.9	0.38	0.42	
25 1 1/8	4 7/16	3/4	13/64	3 9/16	7/16	2 25/32	0.315	1.181	1.335	3/8	SBPF206-18 SBPF206 SBPF206-19 SBPF206-20 SBPF207-20	SB206-18 SB206 SB206-19 SB206-20 SB207-20	SAPF206-18 SAPF206 SAPF206-19 SAPF206-20 SAPF207-20	SA206-18 SA206 SA206-19 SA206-20 SA207-20	PF206	19.5	11.3	13.9	0.62	0.65	
30 1 3/16	4 13/16	7/8	13/64	3 15/16	7/16	3 3/16	0.335	1.260	1.437	3/8	SBPF207-22 SBPF207 SBPF207-23	SB207-22 SB207 SB207-23	SAPF207-21 SAPF207-22 SAPF207 SAPF207-23	SA207-21 SA207-22 SA207 SA207-23	PF207	25.7	15.4	13.9	0.82	0.9	

Note 1) H_2 is the minimum size of the mounting hole.

Remark For the dimensions and forms of applicable bearings, see the dimensional tables of ball bearing for unit.

Stamped Steel 2-Bolt Flange Units

SBPFL
Cylindrical bore
(with set screws)
 d 12 ~ 35 mm

SAPFL
Cylindrical bore
(with eccentric locking collar)



SBPFL



SAPFL

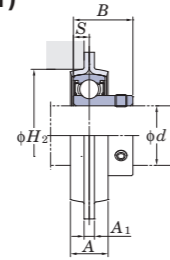

SBPFL

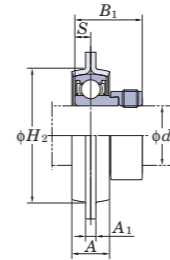
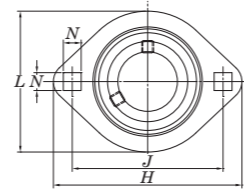

SAPFL

Variations of tolerance of distance between centers of bolt holes (ΔL_b)

Housing No.	Unit: mm
PFL203~PFL207	±0.4

Variations of tolerance of bolt hole diameter (ΔN_b)

Housing No.	Unit: mm
PFL203~PFL207	±0.25

Shaft Dia mm	inch	Dimensions										Bolt Size	Unit No.	Bearing No.	Unit No.	Bearing No.	Housing No.	Basic Load Ratings		Factor	Mass		
		inch mm																inch mm	kN		f_0	kg	
d		H	L	A	A_1	J	N	H_2	S	SBPFL B	SAPFL B_1						C_r	C_{or}		SBPFL	SAPFL		
12	1/2	3 3/16	2 5/16	9/16	5/32	2 1/2	9/32	1 15/16	0.236	0.866	1.122	1/4	SBPFL201 SBPFL201-8 SBPFL202 SBPFL202-10 SBPFL203	SB201 SB201-8 SB202 SB202-10 SB203		SAPFL201 SAPFL201-8 SAPFL202 SAPFL202-10 SAPFL203							
15	5/8	81	59	14	4	63.5	7.1	49	6	22	28.5	M6				PFL203	9.55	4.80	13.2	0.19	0.22		
17																							
20	3/4	3 17/32	2 5/8	5/8	5/32	2 13/16	23/64	2 5/32	0.276	0.984	1.161	5/16	SBPFL204-12 SBPFL204	SB204-12 SB204		SAPFL204-12 SAPFL204	SA204-12 SA204	PFL204	12.8	6.65	13.2	0.24	0.24
25	7/8	3 3/4	2 25/32	23/32	5/32	2 63/64	23/64	2 3/8	0.295	1.063	1.201	5/16	SBPFL205-14 SBPFL205-15 SBPFL205 SBPFL205-16	SB205-14 SB205-15 SB205 SB205-16		SAPFL205-14 SAPFL205-15 SAPFL205 SAPFL205-16	SA205-14 SA205-15 SA205 SA205-16	PFL205	14.0	7.85	13.9	0.28	0.32
25	1																						
30	1 1/8	4 7/16	3 5/16	3/4	13/64	3 9/16	7/16	2 25/32	0.315	1.181	1.335	3/8	SBPFL206-18 SBPFL206 SBPFL206-19 SBPFL206-20 SBPFL207-20	SB206-18 SB206 SB206-19 SB206-20 SB207-20		SAPFL206-18 SAPFL206 SAPFL206-19 SAPFL206-20 SAPFL207-20	SA206-18 SA206 SA206-19 SA206-20 SA207-20	PFL206	19.5	11.3	13.9	0.38	0.41
35	1 1/4																						
35	1 5/8	4 13/16	3 11/16	7/8	13/64	3 15/16	7/16	3 3/16	0.335	1.260	1.437	3/8	SBPFL207-22 SBPFL207 SBPFL207-23	SB207-22 SB207 SB207-23		SAPFL207-21 SAPFL207-22 SAPFL207 SAPFL207-23	SA207-21 SA207-22 SA207 SA207-23	PFL207	25.7	15.4	13.9	0.66	0.74
35	1 3/8																						
35	1 7/16																						

Note 1) H_2 is the minimum size of the mounting hole.

Remark For the dimensions and forms of applicable bearings, see the dimensional tables of ball bearing for unit.

Take-Up Units

UCT
Cylindrical bore (with set screws)
d (45) ~ (75) mm

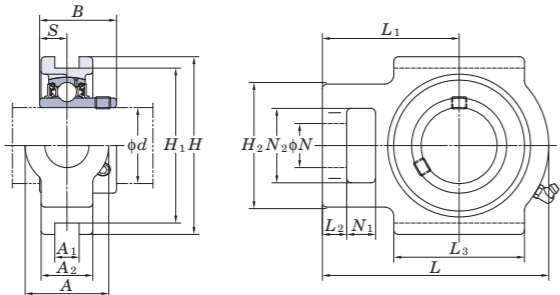

With Pressed Steel Cover

With Cast Iron Cover

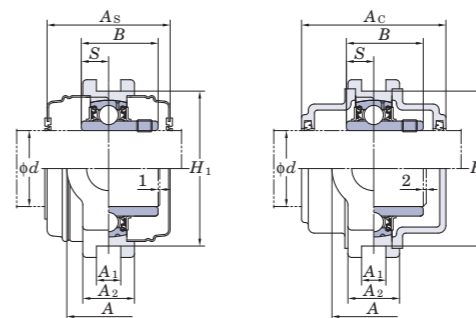

Variations of tolerance of groove width (Δ_{A1s}), variations of tolerance of distance between both grooves (Δ_{H1s}), and tolerance of symmetry of both groove sides (X)

Table with columns for Housing No., Δ_{A1s} , Δ_{H1s} , and X, with rows for T204~T210, T211~T217, T305~T310, T311~T318, T319~T322, T324~T328.

Form and dimensions of L_c of T204JE3 and T205JE3 (housing with cast iron cover) are shown below.

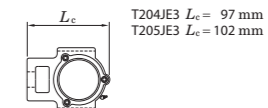

T204JE3 $L_c = 97$ mm
T205JE3 $L_c = 102$ mm

Main dimensions and specifications table for UCT units, including columns for Shaft Dia., Dimensions, Standard (Unit No., Housing No.), Basic Load Ratings, Factor, and With Pressed Steel Cover / With Cast Iron Cover details.

Remarks 1. In Part No. of unit and units with covers, fitting codes follow bore diameter numbers. (See Table 10.5 in P.62.)
2. Part No. of applicable grease fittings are shown below.
B-1/4-28UNF.....201~210, X05~X09, 305~308
B-R1/8.....211~217, X10~X17, 309~328

3. As for the triple seal type product (from 201 to 205 are the double seal type products), suffix code L3 (L2) follows the Part No. of unit or bearing. (Example of Part No.: UCT206JL3, UC206L3)
4. As for the dimensions and forms of applicable bearings, see the dimensional tables of ball bearing for unit.
5. Housings of nodular graphite cast iron are also available.

UCTRS
Cylindrical bore (with set screws)
 d 25 ~ 35 mm

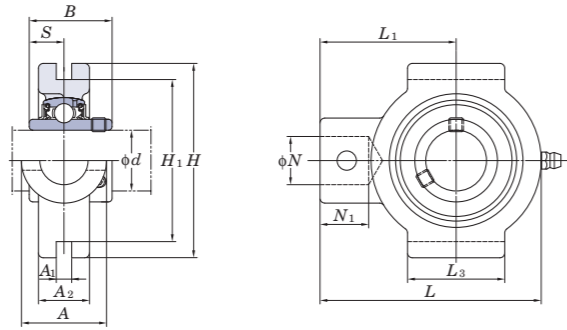

Variations of tolerance of groove width (Δ_{A1s}), variations of tolerance of distance between both grooves (Δ_{H1s}), and tolerance of symmetry of both groove sides (X)

Unit: mm			
Housing No.	Δ_{A1s}	Δ_{H1s}	X
TRS205~TRS207	+0.2 0	0 -0.5	0.5

Shaft Dia. mm inch	Dimensions												Unit No.	Standard Housing No.	Bearing No.	Basic Load Ratings kN	Factor	Mass									
	inch mm																										
d	A	A ₁	A ₂	H	H ₁	L	L ₁	L ₃	N	N ₁	B	S	C_r	C_{0r}	f_0	kg											
25 7/8 15/16	1 3/8	1/4	13/16	3 5/32	2 5/8	3 19/32	2 7/32	1 9/16	25/32	25/32	1.343	0.563	UCTRS205-14 UCTRS205-15 UCTRS205 UCTRS205-16	TRS205	UC205-14 UC205-15 UC205 UC205-16	14.0	7.85	13.9	0.68 0.66 0.65 0.65								
	35	6.35	21	80	66.7	91	56	40	19.84	20	34.1	14.3															
	30 1 3/16 1 1/4	1 3/8	1/4	15/16	4 1/8	3 1/2	4 11/32	2 11/16	2 17/32	3/4	15/16	1.500								0.626	UCTRS206-18 UCTRS206 UCTRS206-19 UCTRS206-20	TRS206	UC206-18 UC206 UC206-19 UC206-20	19.5	11.3	13.9	1.25 1.23 1.23 1.21
		35	6.35	24	105	88.9	110	68	64	19.05	24	38.1								15.9							
35 1 1/4 1 5/16 1 3/8	1 3/8	1/4	31/32	4 1/8	3 1/2	4 1/2	2 11/16	2 17/32	3/4	15/16	1.689	0.689	UCTRS207-20 UCTRS207-21 UCTRS207-22 UCTRS207 UCTRS207-23	TRS207	UC207-20 UC207-21 UC207-22 UC207 UC207-23	25.7	15.4	13.9	1.35 1.31 1.29 1.29 1.26								
	35	6.35	25	105	88.9	114	68	64	19.05	24	42.9	17.5															

- Remarks
- Part No. of applicable grease fittings are shown below.
A-1/4-28UNF 205~207
 - As for the triple seal type product (from 205 is the double seal type products), suffix code L3 (L2) follows the Part No. of unit or bearing.
(Example of Part No.: UCTRS206JL3, UC206L3)
 - As for the dimensions and forms of applicable bearings, see the dimensional tables of ball bearing for unit.
 - Housings of nodular graphite cast iron are also available.

UCTU
Cylindrical bore (with set screws)
 d 85 ~ 90 mm

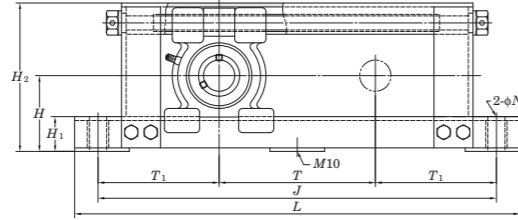
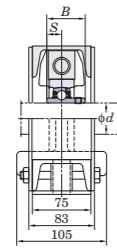

UCTU200

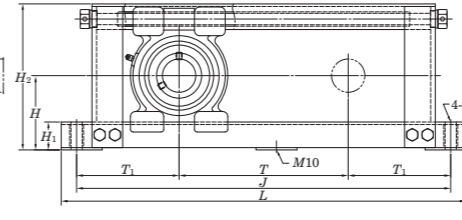
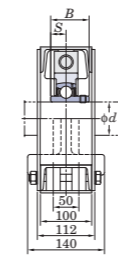
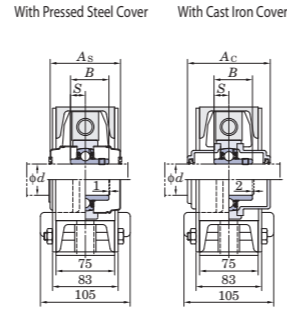

UCTU300

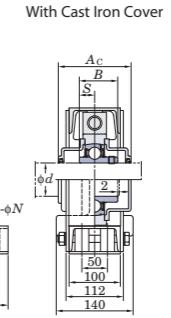

Variations of tolerance of distance from mounting bottom to center of spherical bore (ΔH_s) and variations of tolerance of distance between centers of bolt holes (ΔJ_s)

Nominal unit code	ΔH_s	ΔJ_s
UCTU208~212 UCTU313~315	± 2	± 0.8
UCTU316~318		± 1.2

Unit: mm

Shaft Dia. mm	Dimensions mm										Bolt Size mm	Standard			Basic Load Ratings kN	Factor	With Pressed Steel Cover				With Cast Iron Cover						
	d	H	H_1	H_2	L	J	N	T	T_1	B		S	Unit No.	Bearing No.			Mass kg	C_r	C_{0r}	f_0	Unit No.		Unit No.		Dimension mm	Mass kg	Dimension mm
																		Open Type	One Side Closed Type			Open Type	One Side Closed Type				
85	165	55	325	1,020	960	22	500	230	96	40	M18	UCTU317-500	UC317	62	133	96.8	13.3	-	-	-	-	UCTU317C-500	UCTU317CD-500	146	65		
	165	55	325	1,120	1,060	22	600	230	96	40	M18	UCTU317-600	UC317	64	133	96.8	13.3	-	-	-	-	UCTU317C-600	UCTU317CD-600	146	67		
	165	55	325	1,220	1,160	22	700	230	96	40	M18	UCTU317-700	UC317	67	133	96.8	13.3	-	-	-	-	UCTU317C-700	UCTU317CD-700	146	70		
	165	55	325	1,320	1,260	22	800	230	96	40	M18	UCTU317-800	UC317	69	133	96.8	13.3	-	-	-	-	UCTU317C-800	UCTU317CD-800	146	72		
	165	55	325	1,420	1,360	22	900	230	96	40	M18	UCTU317-900	UC317	71	133	96.8	13.3	-	-	-	-	UCTU317C-900	UCTU317CD-900	146	74		
90	170	55	335	1,050	990	22	500	245	96	40	M18	UCTU318-500	UC318	65	143	107	13.3	-	-	-	-	UCTU318C-500	UCTU318CD-500	150	68		
	170	55	335	1,150	1,090	22	600	245	96	40	M18	UCTU318-600	UC318	67	143	107	13.3	-	-	-	-	UCTU318C-600	UCTU318CD-600	150	70		
	170	55	335	1,250	1,190	22	700	245	96	40	M18	UCTU318-700	UC318	70	143	107	13.3	-	-	-	-	UCTU318C-700	UCTU318CD-700	150	73		
	170	55	335	1,350	1,290	22	800	245	96	40	M18	UCTU318-800	UC318	72	143	107	13.3	-	-	-	-	UCTU318C-800	UCTU318CD-800	150	75		
	170	55	335	1,450	1,390	22	900	245	96	40	M18	UCTU318-900	UC318	74	143	107	13.3	-	-	-	-	UCTU318C-900	UCTU318CD-900	150	77		

- Remarks
1. In Part No. of unit and units with covers, fitting codes follow bore diameter numbers. (See Table 10.5 in P.62.)
 2. Part No. of applicable grease fittings are shown below.
C-1/4-28UNF..... 208~210
C-R1/8..... 211, 212, 313~318
 3. As for the triple seal type product, suffix code L3 follows the Part No. of unit or bearing. (Example of Part No. : UCTU208JL3-500, UC208L3)

4. The unit should be mounted so that load is applied to the frame mounting surface vertically and downward.
5. If heavy load ($P_r/C_r > 0.12$), vibration, or impact occurs, contact with FYH.
6. Tapered bore (with adapter) type bearing units are also available. (Example of Part No. : UKTU208J-500 + H2308X, UK208 + H2308X)
7. If frame parts need to be corrosion resistant, contact with FYH.
8. For the dimensions and forms of applicable bearings, see the dimensional tables of ball bearing for unit.

SBPTH
Cylindrical bore (with set screws)
 d 12 ~ 25 mm

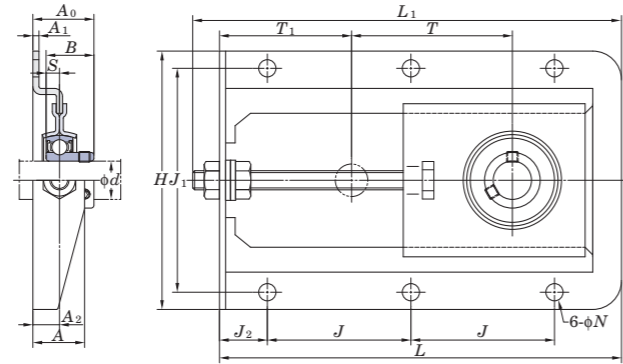
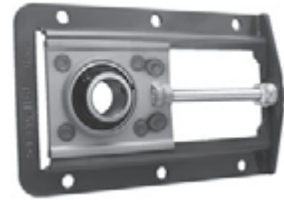

Variations of tolerance of distance between centers of bolt holes ($\Delta J_s, \Delta J_{1s}$)

Nominal unit code	Unit: mm	
	ΔJ_s	ΔJ_{1s}
SBPTH201~SBPTH205	±0.7	±0.7

Shaft Dia. mm d	Dimensions inch mm															Bolt Size inch mm	Unit No.	Bearing No.	Basic Load Ratings kN		Factor f_0	Mass kg
	H	L	L_1	A	J	J_1	J_2	N	T	T_1	A_1	A_2	A_0	B	S				C_r	C_{0r}		
12	5 ^{5/16}	8 ^{9/32}	8 ^{21/32}	1 ^{1/16}	2 ^{61/64}	4 ^{39/64}	3 ^{1/32}	1 ^{1/32}	3 ^{15/32}	2 ^{23/32}	1/8	3 ^{5/64}	1 ^{3/16}	0.866	0.236	5/16	SBPTH201-90	SB201	9.55	4.80	13.2	0.91
	135	210	220	27	75	117	25	9	88	69	3.2	13.9	29.9	22	6	M8						
15	5 ^{5/16}	8 ^{9/32}	8 ^{21/32}	1 ^{1/16}	2 ^{61/64}	4 ^{39/64}	3 ^{1/32}	1 ^{1/32}	3 ^{15/32}	2 ^{23/32}	1/8	3 ^{5/64}	1 ^{3/16}	0.866	0.236	5/16	SBPTH202-90	SB202	9.55	4.80	13.2	0.91
	135	210	220	27	75	117	25	9	88	69	3.2	13.9	29.9	22	6	M8						
17	5 ^{5/16}	8 ^{9/32}	8 ^{21/32}	1 ^{1/16}	2 ^{61/64}	4 ^{39/64}	3 ^{1/32}	1 ^{1/32}	3 ^{15/32}	2 ^{23/32}	1/8	3 ^{5/64}	1 ^{3/16}	0.866	0.236	5/16	SBPTH203-90	SB203	9.55	4.80	13.2	0.91
	135	210	220	27	75	117	25	9	88	69	3.2	13.9	29.9	22	6	M8						
20	5 ^{5/16}	8 ^{9/32}	8 ^{21/32}	1 ^{1/16}	2 ^{61/64}	4 ^{39/64}	3 ^{1/32}	1 ^{1/32}	3 ^{15/32}	2 ^{23/32}	1/8	3 ^{5/64}	1 ^{1/4}	0.984	0.276	5/16	SBPTH204-90	SB204	12.8	6.65	13.2	0.91
	135	210	220	27	75	117	25	9	88	69	3.2	13.9	31.9	25	7	M8						
25	5 ^{5/16}	8 ^{9/32}	8 ^{21/32}	1 ^{1/16}	2 ^{61/64}	4 ^{39/64}	3 ^{1/32}	1 ^{1/32}	3 ^{15/32}	2 ^{23/32}	1/8	3 ^{5/64}	1 ^{5/16}	1.063	0.295	5/16	SBPTH205-90	SB205	14.0	7.85	13.9	0.91
	135	210	220	27	75	117	25	9	88	69	3.2	13.9	33.4	27	7.5	M8						

Remarks 1. For the dimensions and forms of applicable bearings, see the dimensional tables of ball bearing for unit.
2. If heavy load ($P_r/C_r > 0.12$), vibration, or impact occurs, contact with FYH.

SBNPTH
Cylindrical bore (with set screws)
 d 12 ~ 25 mm

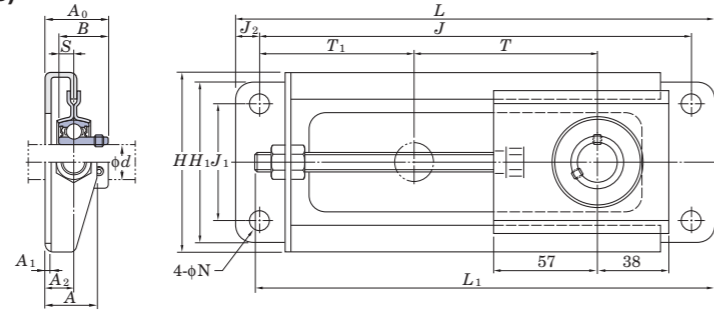

Variations of tolerance of distance between centers of bolt holes ($\Delta J_n, \Delta J_{1n}$)

Nominal unit code	Unit: mm	
	ΔJ_n	ΔJ_{1n}
SBNPTH201~SBNPTH205	±0.7	±0.7

Shaft Dia. mm d	Dimensions																	Bolt Size inch mm	Unit No.	Bearing No.	Basic Load Ratings kN		Factor f_0	Mass kg
	H	H_1	L	L_1	A	J	J_1	J_2	N	T	T_1	A_1	A_2	A_0	B	S	C_r				C_{0r}			
12	$3 \frac{15}{16}$	$3 \frac{17}{32}$	$10 \frac{1}{4}$	$9 \frac{11}{16}$	$1 \frac{1}{16}$	$9 \frac{1}{4}$	$2 \frac{9}{16}$	$\frac{1}{2}$	$\frac{7}{16}$	$3 \frac{15}{16}$	$3 \frac{9}{32}$	$\frac{1}{8}$	$\frac{19}{32}$	$1 \frac{7}{32}$	0.866	0.236	$\frac{5}{16}$	SBNPTH201-100	SB201	9.55	4.80	13.2	0.93	
	100	90	260	246	27	235	65	12.5	11	100	83.5	3.2	15	31	22	6	M8							
15	$3 \frac{15}{16}$	$3 \frac{17}{32}$	$10 \frac{1}{4}$	$9 \frac{11}{16}$	$1 \frac{1}{16}$	$9 \frac{1}{4}$	$2 \frac{9}{16}$	$\frac{1}{2}$	$\frac{7}{16}$	$3 \frac{15}{16}$	$3 \frac{9}{32}$	$\frac{1}{8}$	$\frac{19}{32}$	$1 \frac{7}{32}$	0.866	0.236	$\frac{5}{16}$	SBNPTH202-100	SB202	9.55	4.80	13.2	0.93	
	100	90	260	246	27	235	65	12.5	11	100	83.5	3.2	15	31	22	6	M8							
17	$3 \frac{15}{16}$	$3 \frac{17}{32}$	$10 \frac{1}{4}$	$9 \frac{11}{16}$	$1 \frac{1}{16}$	$9 \frac{1}{4}$	$2 \frac{9}{16}$	$\frac{1}{2}$	$\frac{7}{16}$	$3 \frac{15}{16}$	$3 \frac{9}{32}$	$\frac{1}{8}$	$\frac{19}{32}$	$1 \frac{7}{32}$	0.866	0.236	$\frac{5}{16}$	SBNPTH203-100	SB203	9.55	4.80	13.2	0.93	
	100	90	260	246	27	235	65	12.5	11	100	83.5	3.2	15	31	22	6	M8							
20	$3 \frac{15}{16}$	$3 \frac{17}{32}$	$10 \frac{1}{4}$	$9 \frac{11}{16}$	$1 \frac{1}{16}$	$9 \frac{1}{4}$	$2 \frac{9}{16}$	$\frac{1}{2}$	$\frac{7}{16}$	$3 \frac{15}{16}$	$3 \frac{9}{32}$	$\frac{1}{8}$	$\frac{19}{32}$	$1 \frac{5}{16}$	0.984	0.276	$\frac{5}{16}$	SBNPTH204-100	SB204	12.8	6.65	13.2	0.93	
	100	90	260	246	27	235	65	12.5	11	100	83.5	3.2	15	33	25	7	M8							
25	$3 \frac{15}{16}$	$3 \frac{17}{32}$	$10 \frac{1}{4}$	$9 \frac{11}{16}$	$1 \frac{1}{16}$	$9 \frac{1}{4}$	$2 \frac{9}{16}$	$\frac{1}{2}$	$\frac{7}{16}$	$3 \frac{15}{16}$	$3 \frac{9}{32}$	$\frac{1}{8}$	$\frac{19}{32}$	$1 \frac{11}{32}$	1.063	0.295	$\frac{5}{16}$	SBNPTH205-100	SB205	14.0	7.85	13.9	0.93	
	100	90	260	246	27	235	65	12.5	11	100	83.5	3.2	15	34.5	27	7.5	M8							

Remarks 1. For the dimensions and forms of applicable bearings, see the dimensional tables of ball bearing for unit.
2. If heavy load ($P_r/C_r > 0.12$), vibration, or impact occurs, contact with FYH.

UCC
Cylindrical bore (with set screws)
 d 90 ~ 140 mm

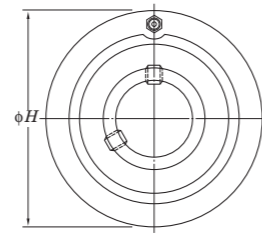
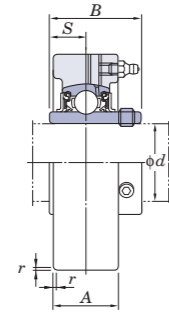

Shaft Dia. mm inch	Dimensions inch mm					Unit No.	Housing No.	Bearing No.	Basic Load Ratings kN		Factor f_0	Mass kg
	d	H	A	r	B				S	C_r		
90 3 1/2	8.858	2 19/32	0.16	3.780	1.575	UCC318-56 UCC318	C318	UC318-56 UC318	143	107	13.3	13.1
	225	66	4	96	40							
95 -	9.449	2 53/64	0.16	4.055	1.614	UCC319	C319	UC319	153	119	13.3	15.8
	240	72	4	103	41							
100 3 15/16 4	10.236	2 61/64	0.16	4.252	1.654	UCC320 UCC320-63 UCC320-64	C320	UC320 UC320-63 UC320-64	173	141	13.2	19.6
	260	75	4	108	42							
105 -	10.236	2 61/64	0.16	4.409	1.732	UCC321	C321	UC321	184	153	13.2	27.0
	260	75	4	112	44							
110 -	11.811	3 5/32	0.2	4.606	1.811	UCC322	C322	UC322	205	180	13.2	29.2
	300	80	5	117	46							
120 -	12.598	3 35/64	0.2	4.961	2.008	UCC324	C324	UC324	207	185	13.5	35.9
	320	90	5	126	51							
130 -	13.386	3 15/16	0.24	5.315	2.126	UCC326	C326	UC326	229	214	13.6	43.0
	340	100	6	135	54							
140 -	14.173	3 15/16	0.24	5.709	2.323	UCC328	C328	UC328	253	246	13.6	52.9
	360	100	6	145	59							

- Remarks
- In Part No. of unit and units with covers, fitting codes follow bore diameter numbers. (See Table 10.5 in P.62.)
 - Part No. of applicable grease fittings are shown below.
A-1/4-28UNF 201~213, X05~X12, 305~308
A-R1/8 309~328
 - As for the triple seal type product (from 201 to 205 are the double seal type products), suffix code L3 (L2) follows the Part No. of unit or bearing.
(Example of Part No. : UCC206L3, UC206L3)
 - For the dimensions and forms of applicable bearings, see the dimensional tables of ball bearing for unit.

Variations of tolerance of outside diameter (ΔH_h), variations of tolerance of width (ΔA_s), and tolerance of circumferential runout of outside diameter (Y)

Housing No.		ΔH_h	ΔA_s	Y
C204~C205		0 -0.030	±0.2	0.2
C206~C210	CX05~CX08 C305~C308	0 -0.035		
	CX09~CX10 C309~C310	0	±0.3	0.3
C211~C213	CX11~CX12 C311~C314	-0.040		
	C315~C318	0		
	C319	-0.046		
	C320~C322	0 -0.052		
	C324~C328	0 -0.057	0.4	

UC, SB, SB-RKP8, SU
Cylindrical bore (with set screws)
d 45 ~ (75) mm

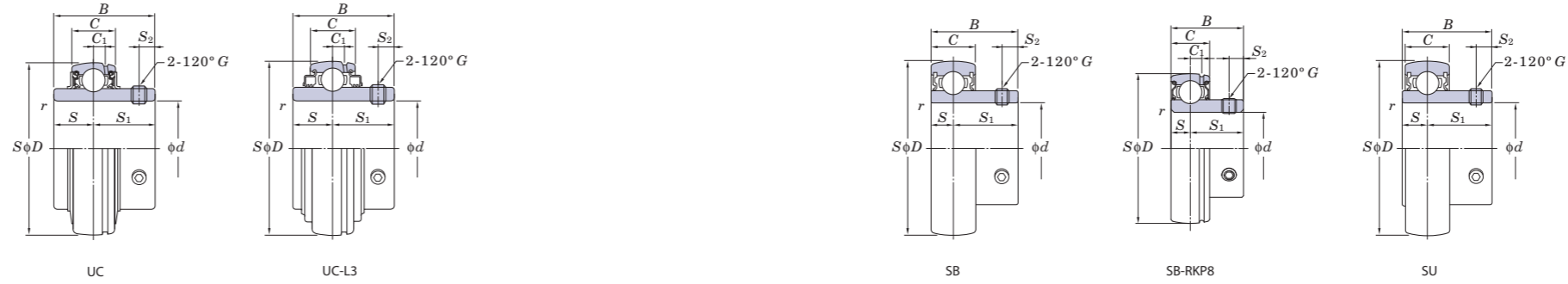
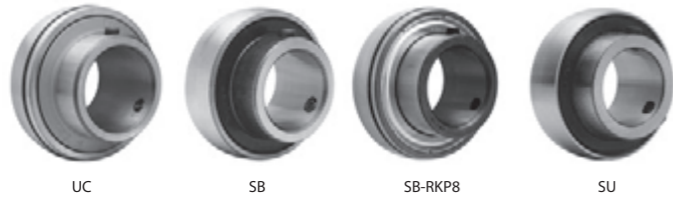
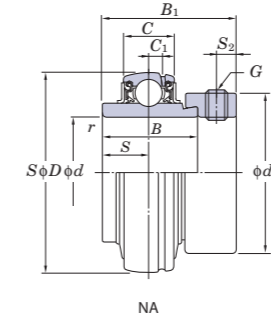
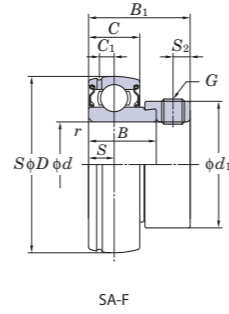
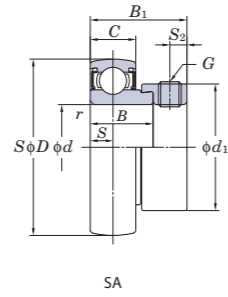

Table with columns: Shaft Dia. (mm, inch), Dimensions (D, B, C, r, C1, S, S1, S2), Basic Load Ratings (Cr, Cor), Factor (f0), Bearing No. (Standard, L3 Type), Dimensions (C1, S, S1, S2), Set Screw Brg. Bore G, and Mass (kg). Rows list various models for shaft diameters from 45 to 75 mm.

Remarks 1. SU type product is the clean series ball bearing for unit.
2. From UC201 to 205 are the double seal type products (L2).

SA, SA-F, NA
Cylindrical bore
(with eccentric locking collar)
d 65 ~ 75 mm



Shaft Dia mm inch <i>d</i>		Dimensions								Basic Load Ratings kN <i>C_r</i> <i>C_{0r}</i>		Factor <i>f₀</i>	Bearing No.	Dimensions								Set Screw Brg. Bore		Mass kg		
		<i>D</i>	<i>B</i>		<i>B₁</i>		<i>C</i>		<i>r</i> (min.)					<i>C₁</i>	<i>S</i>		<i>S₂</i>		<i>d₁</i>		mm	inch				
mm	inch	mm	inch	mm	inch	mm	inch	mm	inch	mm	inch	mm	inch	mm	inch	mm	inch	mm	inch	mm	inch	mm	inch	kg		
65	2 1/2	120	4.724	68.2	2.685	85.7	3.374	28	1.102	1.5	0.059	57.2	40.1	14.4	NA213-40	7.5	0.295	34.1	1.343	8.5	0.335	92	3.622	-	3/8-24UNF	2.51
		120	4.724	68.2	2.685	85.7	3.374	28	1.102	1.5	0.059	57.2	40.1	14.4	NA213	7.5	0.295	34.1	1.343	8.5	0.335	92	3.622	M10x1.25	-	2.45
70	2 3/4	125	4.921	68.2	2.685	85.7	3.374	30	1.181	1.5	0.059	62.2	44.1	14.5	NA214-44	9	0.354	34.1	1.343	8.5	0.335	97	3.819	-	3/8-24UNF	2.94
		125	4.921	68.2	2.685	85.7	3.374	30	1.181	1.5	0.059	62.2	44.1	14.5	NA214	9	0.354	34.1	1.343	8.5	0.335	97	3.819	M10x1.25	-	2.92
		150	5.906	68.3	2.689	92.1	3.626	40	1.575	2.1	0.083	104	68.2	13.2	NA314-43	12.5	0.492	34.1	1.343	11.9	0.469	101.6	4.000	-	1/2-20UNF	4.7
75	2 11/16	130	5.118	74.6	2.937	92.1	3.626	32	1.260	1.5	0.059	67.4	48.3	14.5	NA215	9	0.354	37.3	1.469	8.5	0.335	102	4.016	M10x1.25	-	2.74
		130	5.118	74.6	2.937	92.1	3.626	32	1.260	1.5	0.059	67.4	48.3	14.5	NA215-48	9	0.354	37.3	1.469	8.5	0.335	102	4.016	-	3/8-24UNF	2.72
		160	6.299	74.6	2.937	100	3.937	42	1.654	2.1	0.083	113	77.2	13.2	NA315-47	14.5	0.571	37.3	1.469	12.7	0.500	112.7	4.437	-	5/8-18UNF	5.8

NC2
Cylindrical bore
(with concentric locking collar)
 d 20 ~ 60 mm

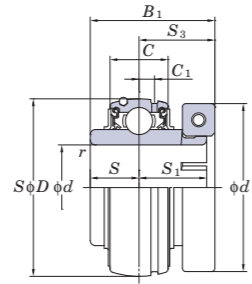

Shaft Dia. mm inch d	Dimensions									Basic Load Ratings kN		Factor f_0	Bearing No.	Collar No.	Dimensions									Cap Screw inch mm	Mass kg
	D mm inch	B_1 mm inch	C mm inch	r mm inch	C_r	C_{0r}	C_1 mm inch	S mm inch	S_1 mm inch	S_2 mm inch	S_3 mm inch				d_1 mm inch										
20 3/4	47 1.850	32.5 1.280	16 0.630	1 0.039	12.8	6.65	4	0.157	12.7	0.500	18.3	0.720	19.8	0.780	44.5	1.752	No.8-32UNC M4x0.7	0.30							
25 7/8 15/16	52 2.047	36.5 1.437	17 0.669	1 0.039	14.0	7.85	5	0.197	14.3	0.563	19.8	0.780	22.2	0.874	49.2	1.937	No.8-32UNC No.8-32UNC M4x0.7 No.8-32UNC	0.40							
30 1 1 1/8 1 3/16 1 1/4	62 2.441	39.7 1.563	19 0.748	1 0.039	19.5	11.3	5	0.197	15.9	0.626	22.2	0.874	23.8	0.937	55.6	2.189	No.8-32UNC M4x0.7 No.8-32UNC No.8-32UNC	0.50							
35 1 1/4 1 3/8	72 2.835	44.5 1.752	20 0.787	1.1 0.043	25.7	15.4	5.5	0.217	17.5	0.689	25.4	1.000	27	1.063	61.9	2.437	No.10-24UNC	0.80							
	72 2.835	44.5 1.752	20 0.787	1.1 0.043	25.7	15.4	5.5	0.217	17.5	0.689	25.4	1.000	27	1.063	65.1	2.563	No.10-24UNC M5x0.8 No.10-24UNC	0.80							
40 1 1/2	80 3.150	50.8 2.000	21 0.827	1.1 0.043	29.1	17.8	6	0.236	19	0.748	30.2	1.189	31.8	1.252	68.3	2.689	No.10-24UNC M5x0.8	1.0							
45 1 5/8 1 11/16 1 3/4	85 3.346	50.8 2.000	22 0.866	1.1 0.043	34.1	21.3	6	0.236	19	0.748	30.2	1.189	31.8	1.252	71.4	2.811	No.10-24UNC	1.1							
	85 3.346	50.8 2.000	22 0.866	1.1 0.043	34.1	21.3	6	0.236	19	0.748	30.2	1.189	31.8	1.252	74.6	2.937	No.10-24UNC M5x0.8	1.1							
50 1 15/16 2	90 3.543	53.1 2.091	24 0.945	1.1 0.043	35.1	23.3	6	0.236	19	0.748	32.6	1.283	34.1	1.343	85.7	3.374	1/4-20UNC M6x1	1.4							
	100 3.937	57.1 2.248	25 0.984	1.5 0.059	43.4	29.4	7	0.276	22.2	0.874	33.4	1.315	34.9	1.374	88.9	3.500	1/4-20UNC	1.5							
55 2 2 3/16	100 3.937	57.1 2.248	25 0.984	1.5 0.059	43.4	29.4	7	0.276	22.2	0.874	33.4	1.315	34.9	1.374	92.1	3.626	M6x1 1/4-20UNC	1.5							
	110 4.331	66.7 2.626	27 1.063	1.5 0.059	52.4	36.2	7.5	0.295	25.4	1.000	39.7	1.563	41.3	1.626	103.2	4.063	5/16-18UNC	2.2							
60 2 1/4 2 7/16	110 4.331	66.7 2.626	27 1.063	1.5 0.059	52.4	36.2	7.5	0.295	25.4	1.000	39.7	1.563	41.3	1.626	104.8	4.126	M8x1.25 5/16-18UNC	2.2							

ERC
Cylindrical bore
(with concentric locking collar)
Cylindrical O. D.
d 20 ~ 60 mm

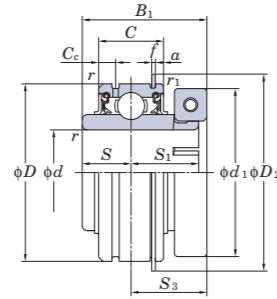

Shaft Dia. mm inch	Dimensions										Basic Load Ratings kN		Factor f ₀	Bearing No.	Collar No.	Dimensions										Cap Screw inch mm	Mass kg
	d	D	B ₁		C		r	r ₁ (min.)		C _r	C _{0r}	C _c				S	S ₁	S ₃	a	f	d ₁	D ₂					
mm	mm	mm	mm	mm	mm	mm	mm	mm	mm	mm	mm	mm	mm	mm	mm	mm	mm	mm	mm	mm	mm	mm	mm	mm			
20 ³ / ₄	47 1.850	32.5 1.280	16 0.630	1 0.039	0.5 0.020	12.8	6.65	13.2	ERC204-12 ERC204	UCL204B UCL204BM	4	0.157	12.7 0.500	18.3 0.720	19.8 0.780	2.38	0.094	1.07 0.042	44.5 1.752	52.5 2.067	No.8-32UNC M4x0.7	0.36					
25 ⁷ / ₈ ¹⁵ / ₁₆	52 2.047	36.5 1.437	19 0.748	1 0.039	0.5 0.020	14.0	7.85	13.9	ERC205-14 ERC205-15 ERC205 ERC205-16	UCL205A UCL205A UCL205AM UCL205A	5	0.197	14.3 0.563	19.8 0.780	22.2 0.874	2.38	0.094	1.07 0.042	49.2 1.937	57.7 2.272	No.8-32UNC No.8-32UNC M4x0.7 No.8-32UNC	0.47					
30 1 ¹ / ₈ ¹ / ₁₆ ¹ / ₄	62 2.441	39.7 1.563	22 0.866	1 0.039	0.5 0.020	19.5	11.3	13.9	ERC206-18 ERC206 ERC206-19 ERC206-20	UCL206A UCL206AM UCL206A UCL206A	5.5	0.217	15.9 0.626	22.2 0.874	23.8 0.937	3.18	0.125	1.65 0.065	55.6 2.189	67.5 2.657	No.8-32UNC M4x0.7 No.8-32UNC No.8-32UNC	0.57					
35 ¹ / ₄ ¹ / ₈ ⁷ / ₁₆	72 2.835	44.5 1.752	24 0.945	1.1 0.043	0.5 0.020	25.7	15.4	13.9	ERC207-20 ERC207-22 ERC207 ERC207-23	UCL207A UCL207B UCL207BM UCL207B	5.5	0.217	17.5 0.689	25.4 1.000	27 1.063	3.18	0.125	1.65 0.065	61.9 2.437	78.4 3.087	No.10-24UNC No.10-24UNC M5x0.8 No.10-24UNC	0.95					
	72 2.835	44.5 1.752	24 0.945	1.1 0.043	0.5 0.020	25.7	15.4	13.9	ERC208-24 ERC208 ERC209-26	UCL208A UCL208AM UCL209A	6	0.236	19 0.748	30.2 1.189	31.8 1.252	3.18	0.125	1.65 0.065	68.3 2.689	86.4 3.402	No.10-24UNC M5x0.8 No.10-24UNC	1.2					
40 ¹ / ₂	85 3.346	50.8 2.000	28 1.102	1.1 0.043	0.5 0.020	34.1	21.3	14.0	ERC209-27 ERC209-28 ERC209 ERC210-31	UCL209B UCL209B UCL209BM UCL210A	6	0.236	19 0.748	30.2 1.189	31.8 1.252	3.18	0.125	1.65 0.065	71.4 2.811	91.4 3.598	No.10-24UNC No.10-24UNC M5x0.8 No.10-24UNC	1.3					
	85 3.346	50.8 2.000	28 1.102	1.1 0.043	0.5 0.020	34.1	21.3	14.0	ERC210-31 ERC210 ERC210-32	UCL210A UCL210AM UCL210A	7.5	0.295	19 0.748	32.6 1.283	34.1 1.343	3.18	0.125	2.41 0.095	85.7 3.374	96.3 3.791	M6x1 1/4-20UNC	1.6					
55 ² / ₁₆ ³ / ₁₆	100 3.937	57.1 2.248	30 1.181	1.5 0.059	0.5 0.020	43.4	29.4	14.4	ERC211-32 ERC211 ERC211-35	UCL211A UCL211BM UCL211B	7.5	0.295	22.2 0.874	33.4 1.315	34.9 1.374	3.18	0.125	2.41 0.095	88.9 3.500	106.3 4.185	1/4-20UNC M6x1 1/4-20UNC	1.8					
	100 3.937	57.1 2.248	30 1.181	1.5 0.059	0.5 0.020	43.4	29.4	14.4	ERC212-36 ERC212	UCL212A UCL212BM	7.5	0.295	25.4 1.000	39.7 1.563	41.3 1.626	3.18	0.125	2.41 0.095	103.2 4.063	116.4 4.583	5/16-18UNC M8x1.25 5/16-18UNC	2.5					
60 ² / ₁₆	110 4.331	66.7 2.626	32 1.260	1.5 0.059	0.5 0.020	52.4	36.2	14.4	ERC212-39	UCL212B	7.5	0.295	25.4 1.000	39.7 1.563	41.3 1.626	3.18	0.125	2.41 0.095	104.8 4.126	116.4 4.583	5/16-18UNC	2.5					

UK
Tapered bore (with adapter)
 d_1 (90) ~ 125 mm

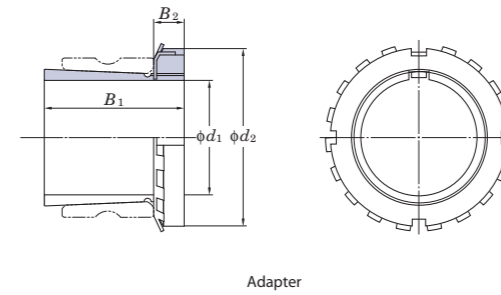
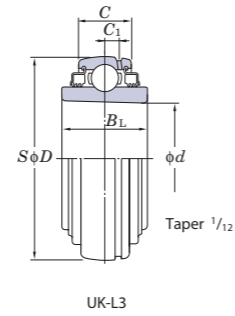
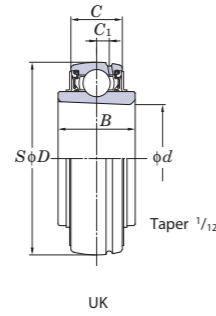

Shaft Dia. mm inch	Dimensions inch mm							Basic Load Ratings kN		Factor f_0	Bearing				Adapter No.	H23 Series Adapter Dimensions inch mm			Mass kg	Sleeve No.
	d_1	d	D	B	B_L	C	C_1	C_r	C_{0r}		No.		Mass kg			B_1	B_2	d_2		
											Standard	L3 Type	Standard	L3 Type						
90 3 1/2	3.937	8.465	2.677	2.677	2.126	0.709	173	141	13.2	UK320	UK320L3	8.70	8.70	HE2320X	3.819	0.787	5.118	2.2	AE2320X	
	100	215	68	68	54	18								H2320X	97	20	130			
100 4	4.331	9.449	3.071	3.071	2.362	0.787	205	180	13.2	UK322	UK322L3	12.2	12.2	H2322X	4.134	0.827	5.709	2.75	A2322X	
	110	240	78	78	60	20								HE2322X	105	21	145			
110 —	4.724	10.236	3.425	3.425	2.520	0.827	207	185	13.5	UK324	UK324L3	16.1	16.1	H2324	4.409	0.866	6.102	3.2	A2324	
	115	260	87	87	64	21								HE2324	112	22	155			
115 4 1/2	5.118	11.024	3.425	3.425	2.677	0.866	229	214	13.6	UK326	UK326L3	18.8	18.8	HE2326	4.764	0.906	6.496	4.6	AE2326	
	125	280	87	87	68	22								H2326	121	23	165			
125 —	5.512	11.811	3.819	3.819	2.835	0.906	253	246	13.6	UK328	UK328L3	23.9	23.9	H2328	5.157	0.945	7.087	5.5	A2328	
	140	300	97	97	72	23								H2328	131	24	180			

Remarks 1. In Part No. of unit with adapters, Part No. of applicable adapters follow the Part No. shown in the dimensional tables.
(Example of Part No. : UK206 + H2306X, UK206L3 + H2306X)

2. Adapter series applicable to UK200 series
UK200 H2300X series
UK200L3 (or L2) H2300X series
3. UK205 is the double seal type product (L2).
4. Inch bore diameter series adapters are also available (see the dimensional tables of adapters).

SBB-RK
Cylindrical bore
 (with set screws)
Cylindrical O. D.
d 12 ~ 55 mm

SAA-FP7
Cylindrical bore
 (with eccentric locking collar)
Cylindrical O. D.

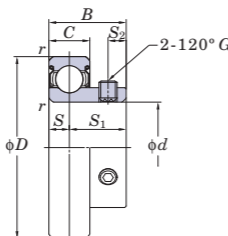

SBB-RK

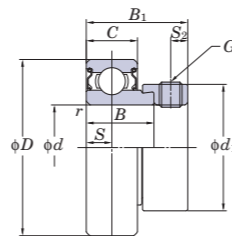

SAA-FP7

Shaft Dia.		Dimensions								Basic Load Ratings		Factor	Bearing No.	Dimensions					Set Screw Brg. Bore		Mass					
mm	inch	D	B	B ₁	C	r (min.)	C ₀	C _{0r}	f ₀	S	S ₁	S ₂		d ₁	mm	inch	kg									
<i>d</i>		mm	inch	mm	inch	mm	inch	mm	inch	mm	inch	mm	inch	mm	inch	mm	inch	mm	inch	kg						
12	—	40	1.575	22	0.866	—	—	12	0.472	0.6	0.024	9.55	4.80	13.2	SBB201RK	6	0.236	4	0.157	—	—	M5×0.5	—	0.10		
	—	40	1.575	19.1	0.752	28.6	1.126	13	0.512	0.6	0.024	9.55	4.80	13.2	SAA201FP7	6.5	0.256	16	0.630	4.8	0.189	28.6	1.126	M6×0.75	—	0.13
—	1/2	40	1.575	22	0.866	—	—	12	0.472	0.6	0.024	9.55	4.80	13.2	SBB201-8RK	6	0.236	16	0.630	4	0.157	—	—	—	No.10-32UNF	0.10
	—	40	1.575	19.1	0.752	28.6	1.126	13	0.512	0.6	0.024	9.55	4.80	13.2	SAA201-8FP7	6.5	0.256	16	0.630	4.8	0.189	28.6	1.126	—	1/4-28UNF	0.13
15	—	40	1.575	22	0.866	—	—	12	0.472	0.6	0.024	9.55	4.80	13.2	SBB202RK	6	0.236	4	0.157	—	—	M5×0.5	—	0.10		
	—	40	1.575	19.1	0.752	28.6	1.126	13	0.512	0.6	0.024	9.55	4.80	13.2	SAA202FP7	6.5	0.256	16	0.630	4.8	0.189	28.6	1.126	M6×0.75	—	0.13
—	5/8	40	1.575	22	0.866	—	—	12	0.472	0.6	0.024	9.55	4.80	13.2	SBB202-10RK	6	0.236	16	0.630	4	0.157	—	—	—	No.10-32UNF	0.10
17	—	40	1.575	22	0.866	—	—	12	0.472	0.6	0.024	9.55	4.80	13.2	SBB203RK	6	0.236	4	0.157	—	—	M5×0.5	—	0.10		
	—	40	1.575	19.1	0.752	28.6	1.126	13	0.512	0.6	0.024	9.55	4.80	13.2	SAA203FP7	6.5	0.256	16	0.630	4.8	0.189	28.6	1.126	M6×0.75	—	0.13
—	3/4	47	1.850	25	0.984	—	—	14	0.551	1	0.039	12.8	6.65	13.2	SBB204-12RK	7	0.276	18	0.709	5	0.197	—	—	—	1/4-28UNF	0.15
	—	47	1.850	21.5	0.846	31	1.220	15	0.591	1	0.039	12.8	6.65	13.2	SAA204-12FP7	7.5	0.295	18	0.709	4.8	0.189	33.3	1.311	—	1/4-28UNF	0.19
20	—	47	1.850	25	0.984	—	—	14	0.551	1	0.039	12.8	6.65	13.2	SBB204RK	7	0.276	18	0.709	5	0.197	—	—	M6×0.75	—	0.15
	—	47	1.850	21.5	0.846	31	1.220	15	0.591	1	0.039	12.8	6.65	13.2	SAA204FP7	7.5	0.295	18	0.709	4.8	0.189	33.3	1.311	M6×0.75	—	0.19
—	7/8	52	2.047	27	1.063	—	—	15	0.591	1	0.039	14.0	7.85	13.9	SBB205-14RK	7.5	0.295	19.5	0.768	5.5	0.217	—	—	—	1/4-28UNF	0.18
—	15/16	52	2.047	27	1.063	—	—	15	0.591	1	0.039	14.0	7.85	13.9	SBB205-15RK	7.5	0.295	19.5	0.768	5.5	0.217	—	—	—	1/4-28UNF	0.18
	—	52	2.047	21.5	0.846	31	1.220	15	0.591	1	0.039	14.0	7.85	13.9	SAA205-15FP7	7.5	0.295	19.5	0.768	4.8	0.189	38.1	1.500	—	1/4-28UNF	0.23
25	—	52	2.047	27	1.063	—	—	15	0.591	1	0.039	14.0	7.85	13.9	SBB205RK	7.5	0.295	19.5	0.768	5.5	0.217	—	—	M6×0.75	—	0.18
	—	52	2.047	21.5	0.846	31	1.220	15	0.591	1	0.039	14.0	7.85	13.9	SAA205FP7	7.5	0.295	19.5	0.768	4.8	0.189	38.1	1.500	M6×0.75	—	0.23
—	1	52	2.047	27	1.063	—	—	15	0.591	1	0.039	14.0	7.85	13.9	SBB205-16RK	7.5	0.295	19.5	0.768	5.5	0.217	—	—	—	1/4-28UNF	0.18
	—	52	2.047	21.5	0.846	31	1.220	15	0.591	1	0.039	14.0	7.85	13.9	SAA205-16FP7	7.5	0.295	19.5	0.768	4.8	0.189	38.1	1.500	—	1/4-28UNF	0.23
—	1 1/8	62	2.441	30	1.181	—	—	16	0.630	1	0.039	19.5	11.3	13.9	SBB206-18RK	8	0.315	22	0.866	6	0.236	—	—	—	1/4-28UNF	0.27
	—	62	2.441	23.8	0.937	35.7	1.406	18	0.709	1	0.039	19.5	11.3	13.9	SAA206-18FP7	9	0.354	22	0.866	6	0.236	44.5	1.752	—	5/16-24UNF	0.34
30	—	62	2.441	30	1.181	—	—	16	0.630	1	0.039	19.5	11.3	13.9	SBB206RK	8	0.315	22	0.866	6	0.236	—	—	M6×0.75	—	0.27
	—	62	2.441	23.8	0.937	35.7	1.406	18	0.709	1	0.039	19.5	11.3	13.9	SAA206FP7	9	0.354	22	0.866	6	0.236	44.5	1.752	M8×1	—	0.34
—	1 3/16	62	2.441	30	1.181	—	—	16	0.630	1	0.039	19.5	11.3	13.9	SBB206-19RK	8	0.315	22	0.866	6	0.236	—	—	—	1/4-28UNF	0.27
	—	62	2.441	23.8	0.937	35.7	1.406	18	0.709	1	0.039	19.5	11.3	13.9	SAA206-19FP7	9	0.354	22	0.866	6	0.236	44.5	1.752	—	5/16-24UNF	0.34
—	1 1/4	62	2.441	30	1.181	—	—	16	0.630	1	0.039	19.5	11.3	13.9	SBB206-20RK	8	0.315	22	0.866	6	0.236	—	—	—	1/4-28UNF	0.27
	—	62	2.441	23.8	0.937	35.7	1.406	18	0.709	1	0.039	19.5	11.3	13.9	SAA206-20FP7	9	0.354	22	0.866	6	0.236	44.5	1.752	—	5/16-24UNF	0.34
—	1 1/4	72	2.835	32	1.260	—	—	17	0.669	1.1	0.043	25.7	15.4	13.9	SBB207-20RK	8.5	0.335	23.5	0.925	6	0.236	—	—	—	1/4-28UNF	0.42
	—	72	2.835	25.4	1.000	38.9	1.531	19	0.748	1.1	0.043	25.7	15.4	13.9	SAA207-20FP7	9.5	0.374	23.5	0.925	6.8	0.268	55.6	2.189	—	5/16-24UNF	0.57
—	1 5/16	72	2.835	25.4	1.000	38.9	1.531	19	0.748	1.1	0.043	25.7	15.4	13.9	SAA207-21FP7	9.5	0.374	—	—	6.8	0.268	55.6	2.189	—	5/16-24UNF	0.57
	—	72	2.835	32	1.260	—	—	17	0.669	1.1	0.043	25.7	15.4	13.9	SBB207-22RK	8.5	0.335	23.5	0.925	6	0.236	—	—	—	1/4-28UNF	0.42
—	1 3/8	72	2.835	25.4	1.000	38.9	1.531	19	0.748	1.1	0.043	25.7	15.4	13.9	SAA207-22FP7	9.5	0.374	23.5	0.925	6.8	0.268	55.6	2.189	—	5/16-24UNF	0.57
	35	72	2.835	32	1.260	—	—	17	0.669	1.1	0.043	25.7	15.4	13.9	SBB207RK	8.5	0.335	23.5	0.925	6	0.236	—	—	M6×0.75	—	0.42
—	72	2.835	25.4	1.000	38.9	1.531	19	0.748	1.1	0.043	25.7	15.4	13.9	SAA207FP7	9.5	0.374	23.5	0.925	6.8	0.268	55.6	2.189	M8×1	—	0.57	
—	1 7/16	72	2.835	32	1.260	—	—	17	0.669	1.1	0.043	25.7	15.4	13.9	SBB207-23RK	8.5	0.335	23.5	0.925	6	0.236	—	—	—	1/4-28UNF	0.42
	—	72	2.835	25.4	1.000	38.9	1.531	19	0.748	1.1	0.043	25.7	15.4	13.9	SAA207-23FP7	9.5	0.374	23.5	0.925	6.8	0.268	55.6	2.189	—	5/16-24UNF	0.57
—	1 1/2	80	3.150	34	1.339	—	—	18	0.709	1.1	0.043	29.1	17.8	14.0	SBB208-24RK	9	0.354	25	0.984	8	0.315	—	—	—	5/16-24UNF	0.60
	—	80	3.150	30.2	1.189	43.7	1.720	22	0.866	1.1	0.043	29.1	17.8	14.0	SAA208-24FP7	11	0.433	—	—	6.8	0.268	60.3	2.374	—	5/16-24UNF	0.75
—	1 9/16	80	3.150	30.2	1.189	43.7	1.720	22	0.866	1.1	0.043	29.1	17.8	14.0	SAA208-25FP7	11	0.433	—	—	6.8	0.268	60.3	2.374	—	5/16-24UNF	0.75
	—	80	3.150	34	1.339	—	—	18	0.709	1.1	0.043	29.1	17.8	14.0	SBB208RK	9	0.354	25	0.984	8	0.315	—	—	M8×1	—	0.60
—	—	80	3.150	30.2	1.189	43.7	1.720	22	0.866	1.1	0.043	29.1	17.8	14.0	SAA208FP7	11	0.433	25	0.984	6.8	0.268	60.3	2.374	M8×1	—	0.75
	—	85	3.346	30.2	1.189	43.7	1.720	22	0.866	1.1	0.043	34.1	21.3	14.0	SAA209-26FP7	11	0.433	—	—	6.8	0.268	63.5	2.500	—	5/16-24UNF	0.82
—	1 11/16	85	3.346	30.2	1.189	43.7	1.720	22																		

SC
Cylindrical bore
 d 17 ~ 40 mm

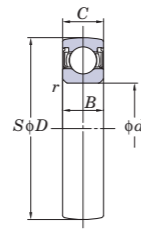
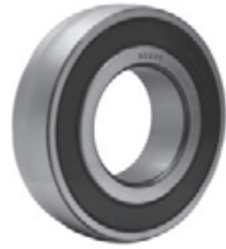

Shaft Dia. mm d	Dimensions								Basic Load Ratings kN		Factor	Bearing No.	Mass kg
	D		B		C		r (min.)		C_0	C_{0r}	f_0		
	mm	inch	mm	inch	mm	inch	mm	inch					
17	40	1.575	12	0.472	12	0.472	0.6	0.024	9.55	4.80	13.2	SC203	0.10
20	47	1.850	14	0.551	14	0.551	1	0.039	12.8	6.65	13.2	SC204	0.15
25	52	2.047	15	0.591	15	0.591	1	0.039	14.0	7.85	13.9	SC205	0.18
30	62	2.441	16	0.630	16	0.630	1	0.039	19.5	11.3	13.9	SC206	0.27
35	72	2.835	17	0.669	17	0.669	1.1	0.043	25.7	15.4	13.9	SC207	0.42
40	80	3.150	18	0.709	18	0.709	1.1	0.043	29.1	17.8	14.0	SC208	0.60

Bearing Adapter

H2300X

d_1 20 ~ 110 mm

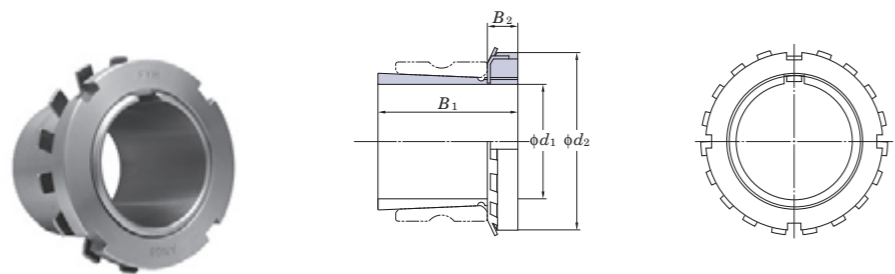

mm	Shaft Dia. d_1 inch				Dimensions inch mm			Adapter No.				Sleeve No.				Lock Nut No.	Washer No.	Mass kg				
	(H)	(HE)	(HS)	(HA)	B_1	B_2	d_2	(H)	(HE)	(HS)	(HA)	(H)	(HE)	(HS)	(HA)			(H)	(HE)	(HS)	(HA)	
20	-	-	-	-	1.378	0.315	1.496	H2305X	-	-	-	-	A2305X	-	-	-	AN05	AW05X	0.095	-	-	-
	$\frac{3}{4}$	-	-	-	35	8	38	-	HE2305X	-	-	-	-	AE2305X	-	-	AN05	AW05X	-	0.085	-	-
25	-	-	-	-	1.496	0.315	1.772	H2306X	-	-	-	-	A2306X	-	-	-	AN06	AW06X	0.13	-	-	-
	1	-	-	-				-	HE2306X	-	-	-	-	-	AE2306X	-	-	-	AN06	AW06X	-	0.12
	-	$\frac{7}{8}$	-	-	38	8	45	-	-	HS2306X	-	-	-	AS2306X	-	-	-	-	-	-	0.16	-
	-	-	-	$\frac{15}{16}$	-	-	-	-	-	-	-	HA2306X	-	-	AA2306X	-	-	-	-	-	-	-
30	-	-	-	-	1.693	0.354	2.047	H2307X	-	-	-	-	A2307X	-	-	-	AN07	AW07X	0.17	-	-	-
	-	-	-	$\frac{3}{16}$	43	9	52	-	-	-	HA2307X	-	-	AA2307X	-	-	-	-	-	-	-	0.17
35	-	-	-	-	1.811	0.394	2.283	H2308X	-	-	-	-	A2308X	-	-	-	AN08	AW08X	0.22	-	-	-
	$1\frac{1}{4}$	-	-	-	46	10	58	-	HE2308X	-	-	-	-	AE2308X	-	-	AN08	AW08X	-	0.28	-	-
40	-	-	-	-	1.969	0.433	2.559	H2309X	-	-	-	-	A2309X	-	-	-	AN09	AW09X	0.28	-	-	-
	$1\frac{1}{2}$	-	-	-				-	HE2309X	-	-	-	-	-	AE2309X	-	-	-	AN09	AW09X	-	0.32
	-	-	-	$\frac{1}{16}$	50	11	65	-	-	-	-	HA2309X	-	-	AA2309X	-	-	-	-	-	-	0.35
	-	-	-	-	-	-	-	H2310X	-	-	-	-	A2310X	-	-	-	AN10	AW10X	0.36	-	-	-
45	$1\frac{3}{4}$	-	-	-	2.165	0.472	2.756	-	HE2310X	-	-	-	-	AE2310X	-	-	AN10	AW10X	-	0.37	-	-
	-	$1\frac{5}{8}$	-	-	55	12	70	-	-	HS2310X	-	-	-	AS2310X	-	-	-	-	-	-	0.46	-
	-	-	-	$\frac{1}{16}$	-	-	-	-	-	-	HA2310X	-	-	AA2310X	-	-	-	-	-	-	-	0.42
	-	-	-	-	-	-	-	H2311X	-	-	-	-	A2311X	-	-	-	AN11	AW11X	0.42	-	-	-
50	2	-	-	-	2.323	0.472	2.953	-	HE2311X	-	-	-	-	AE2311X	-	-	AN11	AW11X	-	0.40	-	-
	-	$1\frac{7}{8}$	-	-	59	12	75	-	-	HS2311X	-	-	-	AS2311X	-	-	AN11	AW11X	-	-	0.50	-
	-	-	-	$\frac{1}{16}$	-	-	-	-	-	-	HA2311X	-	-	AA2311X	-	-	-	-	-	-	-	0.45
	-	-	-	-	2.441	0.512	3.150	H2312X	-	-	-	-	A2312X	-	-	-	AN12	AW12X	0.48	-	-	-
55	-	-	-	-	2.441	0.512	3.150	-	-	-	-	-	AS2312X	-	-	AN12	AW12X	-	-	-	0.52	-
	-	$2\frac{1}{8}$	-	-				62	13	80	-	-	HS2312X	-	-	-	-	-	AN12	AW12X	-	-
	-	-	-	-	-	-	-	H2313X	-	-	-	-	A2313X	-	-	-	AN13	AW13X	0.56	-	-	-
	$2\frac{1}{4}$	-	-	-	2.559	0.551	3.346	-	HE2313X	-	-	-	-	AE2313X	-	-	AN13	AW13X	-	0.69	-	-
60	-	-	-	-	2.559	0.551	3.346	-	-	-	-	-	AS2313X	-	-	AN13	AW13X	-	-	-	0.55	-
	-	$2\frac{3}{8}$	-	-				65	14	85	-	-	HS2313X	-	-	-	-	-	AN13	AW13X	-	-
	-	-	-	$\frac{3}{16}$	-	-	-	-	-	-	HA2313X	-	-	AA2313X	-	-	-	-	-	-	-	0.76
	-	-	-	-	2.874	0.591	3.858	H2315X	-	-	-	-	A2315X	-	-	-	AN15	AW15X	1.05	-	-	-
65	$2\frac{1}{2}$	-	-	-	2.874	0.591	3.858	-	HE2315X	-	-	-	-	AE2315X	-	-	AN15	AW15X	-	1.15	-	-
	-	-	-	$\frac{1}{16}$				73	15	98	-	-	-	-	-	AS2315X	-	-	-	-	-	-
	-	-	-	$\frac{1}{16}$	-	-	-	-	-	-	HA2315X	-	-	AA2315X	-	-	-	-	-	-	-	-
	-	$2\frac{5}{8}$	-	-	-	-	-	-	-	HS2315X	-	-	-	-	-	-	-	-	-	-	0.9	-
70	-	-	-	-	3.071	0.669	4.134	H2316X	-	-	-	-	A2316X	-	-	-	AN16	AW16X	1.3	-	-	-
	$2\frac{3}{4}$	-	-	-				78	17	105	-	HE2316X	-	-	-	-	AE2316X	-	-	AN16	AW16X	-
	-	-	-	$\frac{1}{16}$	-	-	-	-	-	-	HA2316X	-	-	AA2316X	-	-	-	-	-	-	-	1.41
	-	-	-	-	3.228	0.709	4.331	H2317X	-	-	-	-	A2317X	-	-	-	AN17	AW17X	1.45	-	-	-
75	3	-	-	-	3.228	0.709	4.331	-	HE2317X	-	-	-	-	AE2317X	-	-	AN17	AW17X	-	1.35	-	-
	-	-	-	$\frac{1}{16}$				82	18	110	-	-	-	-	-	AS2317X	-	-	-	-	-	-
	-	-	-	-	-	-	-	-	-	-	HA2317X	-	-	AA2317X	-	-	-	-	-	-	-	-
	-	-	-	-	3.386	0.709	4.724	H2318X	-	-	-	-	A2318X	-	-	-	AN18	AW18X	1.7	-	-	-
80	$3\frac{1}{4}$	-	-	-	3.386	0.709	4.724	-	HE2318X	-	-	-	-	AE2318X	-	-	-	-	-	-	1.49	-
	-	-	-	$\frac{3}{16}$				86	18	120	-	-	-	-	-	AS2318X	-	-	-	-	-	-
	-	-	-	-	-	-	-	-	-	-	HA2318X	-	-	AA2318X	-	-	-	-	-	-	-	-
	-	-	-	-	3.543	0.748	4.921	H2319X	-	-	-	-	A2319X	-	-	-	AN19	AW19X	1.95	-	-	-
85	$3\frac{1}{4}$	-	-	-	3.543	0.748	4.921	-	HE2319X	-	-	-	-	AE2319X	-	-	AN19	AW19X	-	2.15	-	-
	-	-	-	$\frac{1}{16}$				90	19	125	-	-	-	-	-	AS2319X	-	-	-	-	-	-
	-	-	-	-	-	-	-	-	-	-	HA2319X	-	-	AA2319X	-	-	-	-	-	-	-	-
	-	-	-	-	3.819	0.787	5.118	H2320X	-	-	-	-	A2320X	-	-	-	AN20	AW20X	2.2	-	-	-
90	$3\frac{1}{2}$	-	-	-	3.819	0.787	5.118	-	HE2320X	-	-	-	-	AE2320X	-	-	AN20	AW20X	-	2.3	-	-
	-	-	-	$\frac{3}{16}$				97	20	130	-	-	-	-	-	AS2320X	-	-	-	-	-	-
	-	-	-	-	-	-	-	-	-	-	HA2320X	-	-	AA2320X	-	-	-	-	-	-	-	-
	-	-	-	-	4.134	0.827	5.709	H2322X	-	-	-	-	A2322X	-	-	-	AN22	AW22X	2.75	-	-	-
100	4	-	-	-	4.134	0.827	5.709	-	HE2322X	-	-	-	-	AE2322X	-	-	AN22	AW22X	-	2.55	-	-
	-	-	-	$\frac{1}{16}$				105	21	145	-	-	-	-	-	AS2322X	-	-	-	-	-	-
	-	-	-	-	-	-	-	-	-	-	HA2322X	-	-	AA2322X	-	-	-	-	-	-	-	-
	-	-	-	-	4.409	0.866	6.102	H2324	-	-	-	-	A2324	-	-	-	AN24	AW24	3.2	-	-	-
110	$4\frac{1}{4}$	-	-	-	4.409	0.866	6.102	-	HE2324	-	-	-	-	AE2324	-	-	-	-	-	-	3.5	-
	-	-	-	$\frac{3}{16}$				112	22	155	-	-	-	HA2324	-	-	AA2324	-	-	-	-	-

H2300X
 d_1 115 ~ 125 mm

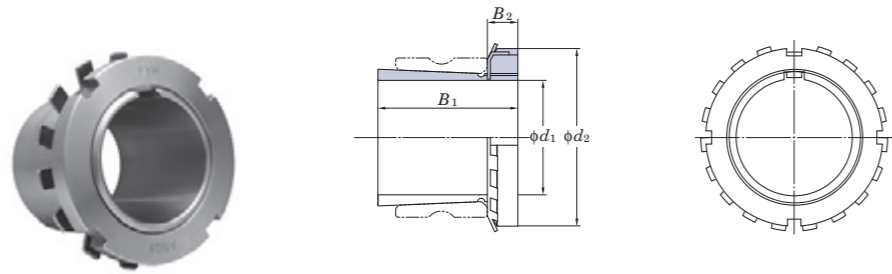

mm	Shaft Dia. d_1				Dimensions			Adapter No.				Sleeve No.				Lock Nut No.	Washer No.	Mass				
	(H)	(HE)	(HS)	(HA)	B_1	B_2	d_2	(H)	(HE)	(HS)	(HA)	(H)	(HE)	(HS)	(HA)			(H)	(HE)	(HS)	(HA)	
115	-	-	-	-	4.764	0.906	6.496	H2326	-	-	-	-	A2326	-	-	-	AN26	AW26	4.6	-	-	-
	4 1/2	-	-	-	121	23	165	-	HE2326	-	-	-	-	AE2326	-	-	AN26	AW26	-	4.7	-	-
	-	-	-	4 7/16	-	-	-	-	-	-	-	HA2326	-	-	-	AA2326	-	-	-	-	-	-
125	-	-	-	-	5.157	0.945	7.087	H2328	-	-	-	-	A2328	-	-	-	AN28	AW28	5.5	-	-	-
	5	-	-	-	131	24	180	-	HE2328	-	-	-	-	AE2328	-	-	-	-	-	5.1	-	-
	-	-	-	4 15/16	-	-	-	-	-	-	-	HA2328	-	-	-	AA2328	-	-	-	-	-	-

16 Parts and Accessories

16.1 Part No. of Steel Plate Covers

Table 16.1 Part No. of steel plate cover for UC type bearing

Bearing No.	Shaft dia. (mm)	Steel plate cover No.	
		Open type	Sealed type
UC201	12	C- 4×12	D- 4
UC202	15	C- 4×15	D- 4
UC203	17	C- 4×17	D- 4
UC204	20	C- 4×20	D- 4
UC205	25	C- 5×25	D- 5
UC206	30	C- 6×30	D- 6
UC207	35	C- 7×35	D- 7
UC208	40	C- 8×40	D- 8
UC209	45	C- 9×45	D- 9
UC210	50	C-10×50	D-10
UC211	55	C-11×55	D-11
UC212	60	C-12×60	D-12
UC213	65	C-13×65	D-13
UC214	70	C-14×70	D-14
UC215	75	C-15×75	D-15
UC216	80	C-16×80	D-16
UC217	85	C-17×85	D-17
UC218	90	C-18×90	D-18
UCX05	25	C- 6×25	D- 6
UCX06	30	C- 7×30	D- 7
UCX07	35	C- 8×35	D- 8
UCX08	40	C- 9×40	D- 9
UCX09	45	C-10×45	D-10
UCX10	50	C-11×50	D-11
UCX11	55	C-12×55	D-12
UCX12	60	C-13×60	D-13
UCX13	65	C-14×65	D-14
UCX14	70	C-15×70	D-15
UCX15	75	C-16×75	D-16
UCX16	80	C-17×80	D-17
UCX17	85	C-18×85	D-18

Table 16.2 Part No. of steel plate cover for UK type bearing

Bearing No.	Shaft dia. (mm)	Steel plate cover No.	
		Open type	Sealed type
–			
–			
–			
–			
UK205	20	C- 5×20	D- 5
UK206	25	C- 6×25	D- 6
UK207	30	C- 7×30	D- 7
UK208	35	C- 8×35	D- 8
UK209	40	C- 9×40	D- 9
UK210	45	C-10×45	D-10
UK211	50	C-11×50	D-11
UK212	55	C-12×55	D-12
UK213	60	C-13×60	D-13
–			
UK215	65	C-15×65	D-15
UK216	70	C-16×70	D-16
UK217	75	C-17×75	D-17
UK218	80	C-18×80	D-18
UKX05	20	C- 6×20	D- 6
UKX06	25	C- 7×25	D- 7
UKX07	30	C- 8×30	D- 8
UKX08	35	C- 9×35	D- 9
UKX09	40	C-10×40	D-10
UKX10	45	C-11×45	D-11
UKX11	50	C-12×50	D-12
UKX12	55	C-13×55	D-13
UKX13	60	C-14×60	D-14
–			
UKX15	65	C-16×65	D-16
UKX16	70	C-17×70	D-17
UKX17	75	C-18×75	D-18

Remark In the Part No. of the steel plate covers for shouldered shaft, shaft diameter follows the basic code of the cover. For example, Part No. of the cover for a shaft with 35 mm diameter for UC207 is C-7×35.

16.2 Part No. of Cast Iron Covers

Table 16.3 Part No. of cast iron cover for UC type bearing

Bearing No.	Shaft dia. (mm)	Cast iron cover No.		Mounting bolt (reference)
		Open type	Closed type	
UC204	20	204FC×20 (204FC3×20) ¹⁾	204FD (204FD3) ¹⁾	M3 (M4)
UC205	25	205FC×25 (205FC3×25) ¹⁾	205FD (205FD3) ¹⁾	M3 (M4)
UC206	30	206FC×30	206FD	M4
UC207	35	207FC×35	207FD	M4
UC208	40	208FC×40	208FD	
UC209	45	209FC×45	209FD	
UC210	50	210FC×50	210FD	M4
UC211	55	211FC×55	211FD	
UC212	60	212FC×60	212FD	
UC213	65	213FC×65	213FD	M4
UC214	70	214FC×70	214FD	
UC215	75	215FC×75	215FD	
UC216	80	216FC×80	216FD	M5
UC217	85	217FC×85	217FD	
UC218	90	218FC×90	218FD	
UCX18	90	X18C×90 (X18C3×90) ²⁾	X18D (X18D3) ²⁾	M5
UCX20	100	X20C×100 (X20C3×100) ²⁾	X20D (X20D3) ²⁾	
UC305	25	305C×25	305D	M4
UC306	30	306C×30	306D	
UC307	35	307C×35	307D	
UC308	40	308C×40	308D	M5
UC309	45	309C×45	309D	
UC310	50	310C×50	310D	
UC311	55	311C×55	311D	M5
UC312	60	312C×60	312D	
UC313	65	313C×65	313D	
UC314	70	314C×70	314D	M5
UC315	75	315C×75	315D	
UC316	80	316C×80	316D	
UC317	85	317C×85	317D	M5
UC318	90	318C×90	318D	
UC319	95	319C×95	319D	
UC320	100	320C×100	320D	M5
UC321	105	321C×105	321D	
UC322	110	322C×110	322D	
UC324	120	324C×120	324D	M5
UC326	130	326C×130	326D	M8
UC328	140	328C×140	328D	

Table 16.4 Part No. of cast iron cover for UK type bearing

Bearing No.	Shaft dia. (mm)	Cast iron cover No.		Mounting bolt (reference)
		Open type	Closed type	
–				
UK205	20	205FC×20 (205FC3×20) ¹⁾	205FD (205FD3) ¹⁾	M3 (M4)
UK206	25	206FC×25	206FD	M4
UK207	30	207FC×30	207FD	M4
UK208	35	208FC×35	208FD	
UK209	40	209FC×40	209FD	
UK210	45	210FC×45	210FD	M4
UK211	50	211FC×50	211FD	
UK212	55	212FC×55	212FD	
UK213	60	213FC×60	213FD	M4
–				
UK215	65	215FC×65	215FD	
UK216	70	216FC×70	216FD	M5
UK217	75	217FC×75	217FD	
UK218	80	218FC×80	218FD	
UKX18	80	X18C×80 (X18C3×80) ²⁾	X18D (X18D3) ²⁾	M5
UKX20	90	X20C×90 (X20C3×90) ²⁾	X20D (X20D3) ²⁾	
UK305	20	305C×20	305D	M4
UK306	25	306C×25	306D	
UK307	30	307C×30	307D	
UK308	35	308C×35	308D	M5
UK309	40	309C×40	309D	
UK310	45	310C×45	310D	
UK311	50	311C×50	311D	M5
UK312	55	312C×55	312D	
UK313	60	313C×60	313D	
–				
UK315	65	315C×65	315D	M5
UK316	70	316C×70	316D	
UK317	75	317C×75	317D	M5
UK318	80	318C×80	318D	
UK319	85	319C×85	319D	
UK320	90	320C×90	320D	M5
–				
UK322	100	322C×100	322D	
UK324	110	324C×110	324D	M5
UK326	115	326C×115	326D	M8
UK328	125	328C×125	328D	

Note ¹⁾ Items in parentheses are applicable to the pillow type (P), square four-bolt flange type (F), oval flange type (FL), and the take-up type (T) bearings, and can be mounted to housings with three hexagon socket head cap screws (use four to mount other items).

²⁾ Items in parentheses are applicable to the round flange cartridge type bearing (FC), and can be mounted to housings with three hexagon socket head cap screws (use four to mount other items).

Remark In the nominal codes of the cast iron covers for shouldered shaft, shaft diameter follows the basic code of the cover. For example, Part No. of the cover for a shaft with 60 mm diameter for UC210 is 210FC×60.

FYH®



SPHERICAL ROLLER BEARING UNITS

Contents

1 Structure and Features

1.1 Structure	326
1.2 Features.....	326

2 Models

2.1 Model List.....	329
2.2 Models and Features	330

3 Nomenclature..... 332

4 Engineering Information 332

5 Installation Guide

5.1 Precautions.....	334
5.2 Preparation.....	334
5.3 Installation.....	335
5.4 Lubrication	336

6 Dimensional Tables for Spherical Roller Bearing Units

XS2P, ZS2P	338
<i>d</i> 1 3/8 ~ 4 inch 40 ~ 100 mm	
XSE2P, ZSE2P.....	340
<i>d</i> 1 3/8 ~ 4 inch 40 ~ 100 mm	
XS4F, ZS4F	342
<i>d</i> 1 3/8 ~ 4 inch 40 ~ 100 mm	
XSE4F, ZSE4F.....	344
<i>d</i> 1 3/8 ~ 4 inch 40 ~ 100 mm	
XS4FC, ZS4FC.....	346
<i>d</i> 1 3/8 ~ 4 inch 40 ~ 100 mm	
XST, ZST.....	348
<i>d</i> 1 15/16 ~ 3 1/2 inch 50 ~ 90 mm	
XS4P, ZS4P	350
<i>d</i> 2 7/16 ~ 4 inch 60 ~ 100 mm	
XDS4P, ZDS4P	352
<i>d</i> 2 7/16 ~ 4 inch 60 ~ 100 mm	
XS4, ZS4.....	354
<i>d</i> 1 3/8 ~ 4 inch 40 ~ 100 mm	
XDS4, ZDS4.....	355
<i>d</i> 2 7/16 ~ 4 inch 60 ~ 100 mm	

1 Structure and Features

1.1 Structure

More than sixty years of experience and innovation in the field of mounted ball bearing units has led to the production of mounted spherical roller units that cater to a wide range of applications and industries. Bearing and housing production are accomplished entirely by FYH while utilizing only the highest quality materials available. Through meticulous design enhancements and careful material selection this heavy duty mounted roller series attains the designation of "EXTRA TOUGH".

1.2 Features

FYH spherical roller bearing units have many features and are available in various models. A wide selection of mounted units is offered to fit virtually any application.

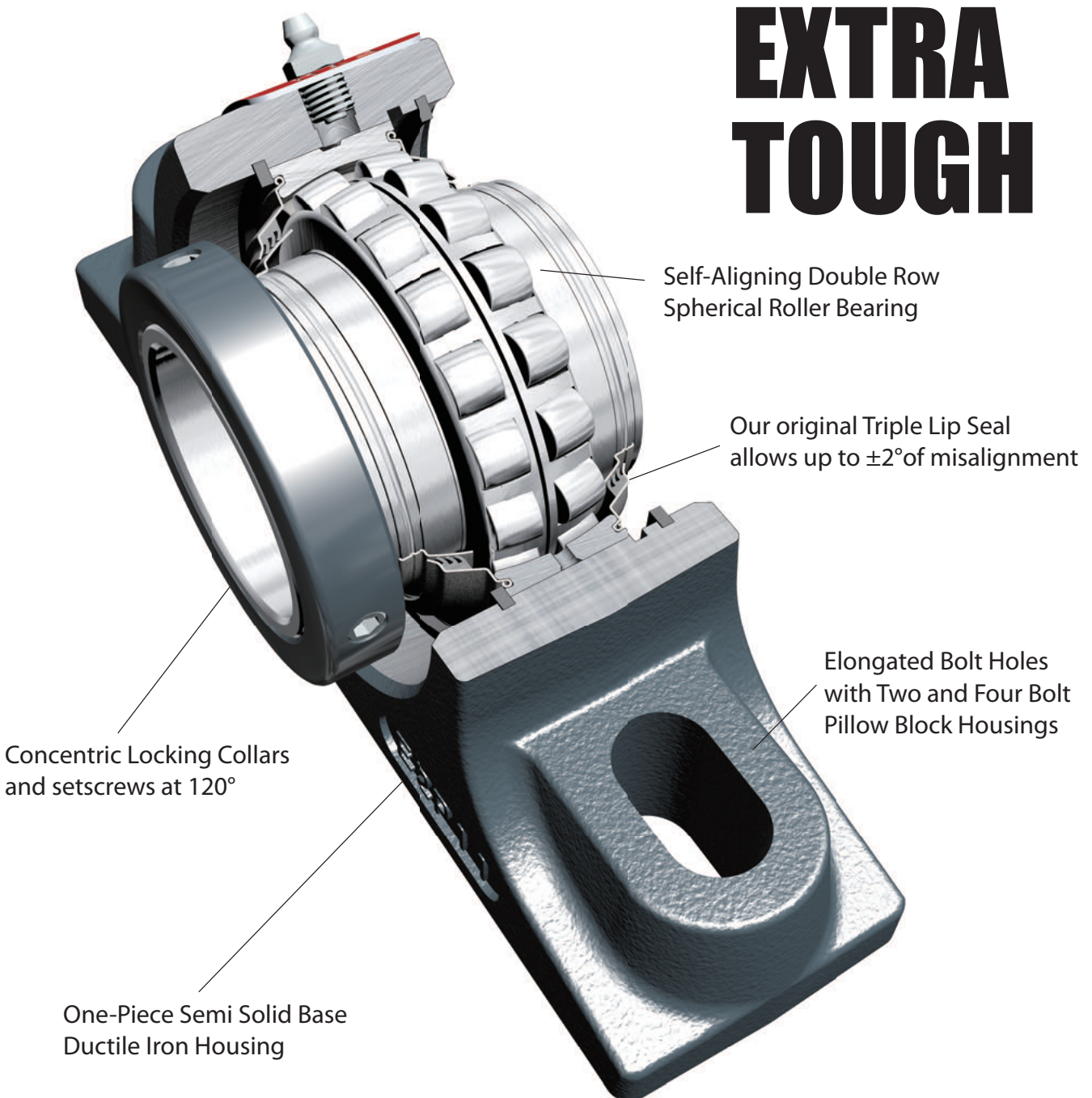

1 Triple Lip Seal

±2° Self Aligning capability

The triple-lip seal maintains positive contact with a special sealing ring at virtually any angle of shaft mis-alignment. Our new patent pending sealing design protects the bearing against a variety of wet and dry contaminants and dramatically improves bearing life. The ability to accommodate shaft expansion is also available.

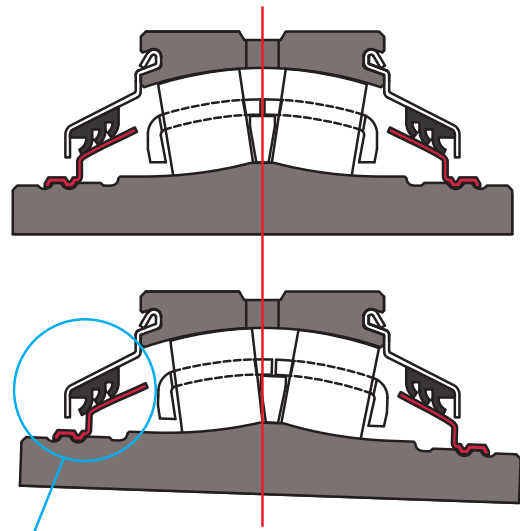

Positive seal contact is maintained during mis-alignment at any angle.

2 Semi Solid Base

One piece ductile iron housings

Ductile iron housings are approximately twice as strong as cast iron, and the semi-solid base design provides an excellent mounting foundation and superior rigidity over competitive offerings. The standard housing material from FYH is ductile iron, and additional material options may also be available.



3 Lubrication

FYH Roller Grease is a calcium sulfonate complex thickened lubricating grease formulated in 100% synthetic hydrocarbon base oil. FYH Roller Grease has excellent low temperature and high temperature performance, and it provides excellent extreme pressure and anti-wear protection. FYH Roller Grease also provides excellent corrosion protection and water wash-out resistance. Grease temperature range: -40 to 340°F (-40 to 170°C) FYH Roller Grease is also available in automatic lubricators.

4 Designed to Interchange with the Competition

Units are designed to interchange with most spherical roller unit footprints. Elongated bolt holes are dimensioned to allow for a shortened or extended mounting pitch to accommodate practically any competitive tapered roller or spherical roller design.

5 Convertible from Non-expansion to Expansion

By simply moving a snap ring on the back of the unit the bearing can easily be converted from non-expansion to expansion or vice versa.

This procedure can be easily performed in the field even after the unit has been mounted.



6 Locking Style

The patent pending Z-Lock is the first ever tapered bore locking collar system. Just tighten the cap screws properly and the specialized tapered bore collar provides extreme holding power on the shaft without causing any damage. This is a true 360 degree locking mechanism.

Disassembly is easily accomplished with two threaded holes in the collar for standard withdrawal dismounting.

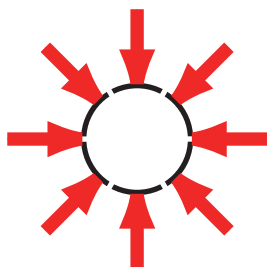

THE MOST REVOLUTIONARY
LOCKING SYSTEM
TRUE 360° GRIP



2 Models

2.1 Model List

Table 2.1 shows the models of FYH Spherical Roller Bearing Units.

Table 2.1 FYH Spherical Roller Bearing Units models

Model	Type	Bearing bore dia. Surface (fixing to shaft)	Model code	Shaft dia.				Dimension table
				(inch)		(mm)		
				min.	max.	min.	max.	
1 SPHERICAL ROLLER BEARING UNITS	(1) 2-Bolt Base Pillow Block Units	with set screw collar lock with Z-Lock	XS2P	1 3/8	4	40	100	P.338
			ZS2P	1 3/8	4	40	100	P.338
	(2) 2-Bolt Base Type E Pillow Units	with set screw collar lock with Z-Lock	XSE2P	1 3/8	4	40	100	P.340
			ZSE2P	1 3/8	4	40	100	P.340
	(3) 4-Bolt Flange Units	with set screw collar lock with Z-Lock	XS4F	1 3/8	4	40	100	P.342
			ZS4F	1 3/8	4	40	100	P.342
	(4) 4-Bolt Type E Flange Units	with set screw collar lock with Z-Lock	XSE4F	1 3/8	4	40	100	P.344
			ZSE4F	1 3/8	4	40	100	P.344
	(5) Flange Cartridge Units	with set screw collar lock with Z-Lock	XS4FC	1 3/8	4	40	100	P.346
			ZS4FC	1 3/8	4	40	100	P.346
	(6) Take-Up Units	with set screw collar lock with Z-Lock	XST	1 15/16	3 1/2	50	90	P.348
			ZST	1 15/16	3 1/2	50	90	P.348
	(7) 4-Bolt Base Pillow Block Units	with set screw collar lock with Z-Lock with set screw collar lock (both) with Z-Lock (both)	XS4P	2 7/16	4	60	100	P.350
			ZS4P	2 7/16	4	60	100	P.350
XDS4P			2 7/16	4	60	100	P.352	
ZDS4P			2 7/16	4	60	100	P.352	
2 SPHERICAL ROLLER BEARING INSERTS	(1) XS Inserts	with set screw collar lock	XS	1 3/8	4	40	100	P.354
	(2) ZS Inserts	with Z-Lock	ZS	1 3/8	4	40	100	P.354
	(3) XDS Inserts	with set screw collar lock (both)	XDS	2 7/16	4	60	100	P.355
	(4) ZDS Inserts	with Z-Lock (both)	ZDS	2 7/16	4	60	100	P.355

2.2 Models and Features

1 SPHERICAL ROLLER BEARING UNITS

1 2-Bolt Base Pillow Block Units

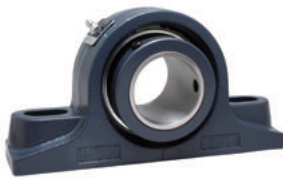

XS2P
XSE2P



ZS2P
ZSE2P

XS2P is a two-bolt pillow block unit with a setscrew locking insert system. This unit is equivalent to many of our competitors SRB style housings.

XSE2P is with Type E mounting dimensions which has a footprint that can accommodate both a tapered roller unit and a spherical roller unit for most shaft sizes.

ZS2P and **ZSE2P** have the same housing dimensions as the above styles but utilize our revolutionary Z-Lock concentric locking collar system.

2 4-Bolt Flange Units



XS4F
XSE4F



ZS4F
ZSE4F

XS4F is a four-bolt flange unit with set screw locking system. It has standard spherical roller unit mounting dimensions and a compact footprint for areas with limited space.

XSE4F has Type E mounting dimensions with the same footprint as a tapered roller unit.

ZS4F and **ZSE4F** have the same housing dimensions as the above units but utilize our revolutionary Z-Lock concentric locking collar system.

3 Flange Cartridge Units



XS4FC



ZS4FC

XS4FC is a piloted flange cartridge unit with a setscrew locking insert system. Its' pilot mounting dimensions are the same as the medium duty ball bearing units that allow for easy upgrades to a heavier duty series. The threaded withdrawal holes make for quick and easy dismounting.

ZS4FC carries as the same housing dimensions as the above unit but incorporate the revolutionary Z-Lock concentric locking collar system.

4 Take-Up Units



XST



ZST

XST is a take-up unit with set screw locking system.

It has rail slots that are compatible with many industrial frame sizes. This unit can safely handle high belt tension and heavy shock loads.

ZST has the same housing dimensions as the XST units but incorporates the revolutionary Z-Lock concentric locking collar system.

5 4-Bolt Base Pillow Block Units



XS4P

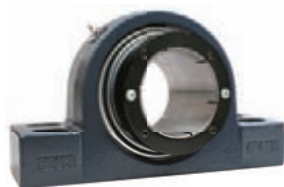

ZS4P

XS4P is a four-bolt base pillow block unit with standard spherical roller bearing mounting dimensions. Four mounting bolt-holes create a firm and secure fit to the mounting surface. The ends of the housing are flat to allow for mounting inside of a fixed frame assembly.

ZS4P is the Z-lock equivalent of the XS4P carrying the same housing dimensions but utilizing the revolutionary Z-Lock concentric locking collar system.

6 4-Bolt Base Pillow Block Units (Double Collar)

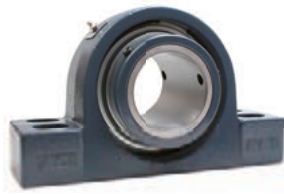

XDS4P

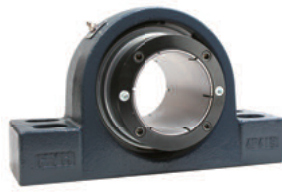

ZDS4P

XDS4P is the same as the XS4P above but utilizes a double lock. This insert has a setscrew locking mechanism on both the front and back of the inner ring.

This additional locking mechanism is helpful in applications where the bearing experiences some thrust loads on the inner ring that could cause a single locking unit to slip.

ZDS4P is the Z-lock equivalent of the XDS4P carrying the same housing dimensions but utilizing the revolutionary Z-Lock concentric locking collar system.

2 SPHERICAL ROLLER BEARING INSERTS

1 Spherical Roller Bearing Inserts (Single Collar)



XS



ZS

XS is a setscrew locking insert that utilizes the patented Bullet Point setscrews at 120 degrees apart to hold shafting firmly in place. This is the most economical type of SRB insert and can be utilized in a wide variety of industrial and agricultural applications.

ZS is a concentric locking insert that utilizes a tapered collar that allows for fast mounting while avoiding damage to shafting that a setscrew unit can cause. The tapered collar keeps the 100% true concentric holding power and does not remove any clearance in the insert by over tightening like the adaptor sleeve locking system can. The unit is tightened down using a hex wrench on the cap screws in a star pattern. The insert can be uninstalled by removing all cap screws and using two of them in the withdrawal holes to disengage the collar.

2 Spherical Roller Bearing Inserts (Double Collar)



XDS



ZDS

XDS is the same as the XS above but utilizes a double lock. This insert has a setscrew locking mechanism on both the front and back of the inner ring. This additional locking mechanism is helpful in applications where the bearing experiences some thrust loads on the inner ring that could cause a single locking unit to slip.

ZDS is the same as the ZS above but utilizes a double lock. This insert has a concentric tapered collar on both the front and back of the inner ring. This additional locking mechanism is helpful in applications where a bearing experiences some thrust loads on the inner ring that could cause a single locking unit to slip.

3 Nomenclature

The nomenclature of a FYH Spherical Roller Unit is comprised of the roller bearing unit model code which is made up using the bearing model code and the housing model code. This in combination with the diameter series code, bore diameter code, accessory code and any special

code for individual applications determines the FYH Spherical Roller Units part number.



http://www.fyhbearings.com/html/nomenclature_r.html

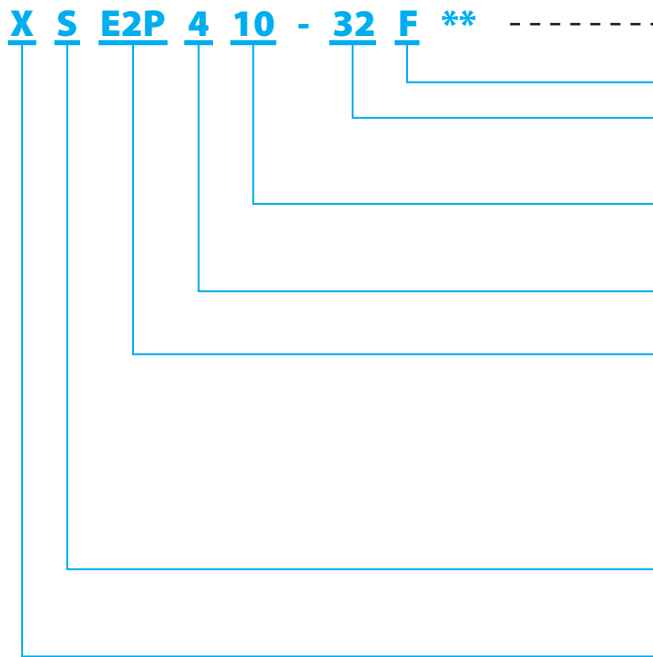

Bearing No.	XS410-32
Housing No.	E2P10

EXPANSION Type

Bore Size (inch)

Number of 1/16" of Inches
(ex. 39 = 2 7/16")

Bore Size (base)

Metric type x 5 mm of Number
(ex. 13 = 65 mm)

Series code

4 Spherical Roller

Housing model code

- 2P 2 - Bolt Pillow Block
- 4P 4 - Bolt Pillow Block
- 4F 4 - Bolt Flange
- 4FC Flange Cartridge
- T Take - Up
- E2P 2 - Bolt Pillow Block : TYPE E (inch)
- E4F 4 - Bolt Flange : TYPE E (inch)

INSERT-2 model code

- S Spherical Roller
- T Taper Roller

INSERT-1 Locking Type code

- X Set Screw Collar Lock
- XD Set Screw Collar Lock (Double Collar)
- Z Z - Lock Concentric Locking System

4 Engineering Information

Spherical Roller Bearing Life Calculations

The relationship between the basic rating life, the basic dynamic load rating, and the dynamic equivalent load of the spherical roller bearing is indicated in Formula A. If the spherical roller bearing unit is being used at a fixed rotating speed, the life is indicated as time.

This is shown in Formula B.

$$A. L_{10} = \left(\frac{C_r}{P_r} \right)^{\frac{10}{3}}$$

$$B. L_{10h} = \frac{10^6 L_{10}}{60n} = \frac{10^6}{60n} \left(\frac{C_r}{P_r} \right)^{\frac{10}{3}}$$

L_{10} : Basic Rating Life 10^6 rotations

L_{10h} : Rated Life (hr)

C_r : Basic Dynamic Load Rating (lbf)

P_r : Dynamic equivalent Load (lbf)

n : Speed (min^{-1})

Basic Loads (lbf)		
Size Code	Dynamic C_r	Static C_{or}
XS408	19967	22744
XS409	20834	24491
XS410	21683	26306
XS411	27191	33029
XS413	39006	49591
XS415	42032	54986
XS418	63910	86343
XS420	81897	111863

Limiting Speed for Seals		
Size Code	Standard Triple Lip Seal Limiting Speeds ($dn=110,000$) RPM	Non Contact Seal Limiting Speeds ($dn=130,000$) RPM
XS408	2750	3200
XS409	2450	2800
XS410	2200	2600
XS411	2000	2360
XS413	1692	2000
XS415	1460	1730
XS418	1220	1440
XS420	1100	1300

Allowable Radial Load (lbf) at Various RPM																				
Shaft Size	Size	L ₁₀ hours	RPM																	
			50	100	150	300	500	750	1000	1200	1400	1600	1800	2000	2200	2400	2600	2800	3000	3200
1 3/8" 1 7/16" 1 1/2" 40 mm	XS408	10000	7197	5846	5177	4205	3607	3194	2930	2774	2649	2545	2456	2380	2313	2253	2200	2151	2107	2067
		25000	5468	4441	3932	3194	2740	2426	2226	2107	2012	1933	1866	1808	1757	1712	1671	1634	1601	1570
		50000	4441	3607	3194	2594	2226	1971	1808	1712	1634	1570	1516	1468	1427	1390	1357	1327	1300	1275
		70000	4015	3261	2887	2345	2012	1782	1634	1547	1477	1419	1370	1327	1290	1257	1227	1200	1175	1153
		100000	3607	2930	2594	2107	1808	1601	1468	1390	1327	1275	1231	1193	1159	1129	1102	1078	1056	1036
1 11/16" 1 3/4" 45 mm	XS409	10000	7510	6100	5401	4387	3764	3333	3057	2894	2764	2655	2563	2483	2413	2351	2295	2245		
		25000	5705	4634	4103	3333	2859	2532	2322	2199	2099	2017	1947	1886	1833	1786	1744	1705		
		50000	4634	3764	3333	2707	2322	2056	1886	1786	1705	1638	1581	1532	1489	1451	1416	1385		
		70000	4189	3402	3013	2447	2099	1859	1705	1615	1542	1481	1430	1385	1346	1311	1280	1252		
		100000	3764	3057	2707	2199	1886	1670	1532	1451	1385	1331	1285	1245	1209	1178	1150	1125		
1 15/16" 2" 50 mm	XS410	10000	7816	6349	5621	4566	3917	3469	3182	3012	2876	2763	2667	2584	2512	2447	2389			
		25000	5937	4823	4270	3469	2976	2635	2417	2288	2185	2099	2026	1963	1908	1859	1815			
		50000	4823	3917	3469	2817	2417	2140	1963	1859	1775	1705	1646	1595	1550	1510	1474			
		70000	4360	3541	3136	2547	2185	1935	1775	1680	1604	1541	1488	1442	1401	1365	1332			
		100000	3917	3182	2817	2288	1963	1738	1595	1510	1442	1385	1337	1295	1259	1226	1197			
2 3/16" 55 mm	XS411	10000	9801	7961	7049	5726	4912	4350	3990	3778	3607	3465	3345	3241	3150					
		25000	7446	6048	5355	4350	3732	3304	3031	2870	2740	2632	2541	2462	2393					
		50000	6048	4912	4350	3533	3031	2684	2462	2331	2226	2138	2064	2000	1943					
		70000	5467	4441	3932	3194	2740	2426	2226	2107	2012	1933	1866	1808	1757					
		100000	4912	3990	3533	2870	2462	2180	2000	1893	1808	1737	1676	1624	1579					
2 7/16" 65 mm	XS413	10000	14060	11421	10113	8214	7047	6240	5724	5419	5174	4971	4798	4649						
		25000	10681	8676	7682	6240	5353	4740	4348	4117	3931	3776	3645	3532						
		50000	8676	7047	6240	5068	4348	3850	3532	3344	3193	3067	2961	2869						
		70000	7843	6370	5641	4582	3931	3480	3193	3023	2886	2773	2677	2593						
		100000	7047	5724	5068	4117	3532	3127	2869	2716	2593	2491	2405	2330						
2 11/16" 2 15/16" 75 mm	XS415	10000	15151	12307	10897	8851	7594	6724	6168	5840	5576	5357								
		25000	11510	9349	8278	6724	5768	5108	4685	4436	4236	4069								
		50000	9349	7594	6724	5461	4685	4149	3806	3603	3440	3305								
		70000	8451	6864	6078	4937	4236	3750	3440	3257	3110	2988								
		100000	7594	6168	5461	4436	3806	3370	3091	2927	2794	2685								
3 7/16" 90 mm	XS418	10000	23037	18712	16569	13458	11546	10224	9378	8879	8478									
		25000	17500	14215	12587	10224	8771	7766	7124	6745	6440									
		50000	14215	11546	10224	8304	7124	6308	5787	5479	5231									
		70000	12850	10437	9242	7507	6440	5703	5231	4953	4729									
		100000	11546	9378	8304	6745	5787	5124	4700	4450	4249									
3 15/16" 100 mm	XS420	10000	29521	23979	21232	17246	14796	13101	12018	11378	10864									
		25000	22426	18215	16129	13101	11240	9952	9129	8643	8253									
		50000	18215	14796	13101	10641	9129	8084	7415	7021	6703									
		70000	16467	13375	11843	9620	8253	7308	6703	6347	6060									
		100000	14796	12018	10641	8643	7415	6566	6023	5703	5445									

1. Blue area: The Standard Triple Lip Seal is used.
2. Green area: A non-contact seal is used.



5 Installation Guide

5.1 Precautions

- Read the entire installation guide prior to beginning.
- Bearings are precision instruments and they must always be handled carefully to prevent damage.
- Store bearings in a cool and dry location, and always leave bearings in original packaging until ready for installation.
- Bearing life calculations should be performed prior to installation to ensure that the selected unit is acceptable for the application.
- The use of more than two bearings on a single shaft is not recommended.
- To maximize the life of the bearing avoid mis-alignment and pre-loading by carefully following these instructions.
- Always lock out the power source and adhere closely to industry safety standards before performing any work on the equipment.

5.2 Preparation

The mounting surface and housing base must be clean, flat, and of sufficient thickness to support the weight of the entire assembly without deflecting or breaking. Make sure that the mounting surface is parallel to the plane of the shaft for pillow blocks, and perpendicular to the shaft for flanges and take-up units. FYH mounted bearings can accommodate up to ± 2 degrees of mis-alignment, however longer bearing life can be achieved if mis-alignment can be minimized during installation.

Check the shaft diameter and make sure that it is within tolerance as indicated in Table 1. Check that the shaft is straight, clean, and free of burrs or other imperfections. Use emery cloth or a fine file to smooth the surface as necessary. A small amount of lubricant may be applied to both the shaft and the bore of the bearing; however lubricant should not be applied to the areas where the bearing locking mechanism contacts the shaft. To ensure adequate locking power between the bearing and shaft the hardness of the shaft should not exceed Rc 45.

Shaft Size (mm)		h6		h7	
		Shaft Speed Greater Than 50% of Max RPM Rating		Shaft Speed Less Than 50% of Max RPM Rating	
Over	Incl.	Max (mm)	Min (mm)	Max (mm)	Min (mm)
30	50	+0	-0.016	+0	-0.025
50	80	+0	-0.019	+0	-0.03
80	120	+0	-0.022	+0	-0.035
120	180	+0	-0.025	+0	-0.04

Converting units from fixed to expansion

FYH mounted roller units are capable of operating in both a fixed or expansion configuration.

Before bearing installation

On the back side of the unit (opposite the housing markings), remove the bearing retaining ring located on the inner diameter of the housing and move it back to the groove on the outer position of the housing. Slide the bearing insert rearward within the housing until it sits against the retaining ring that was just relocated. When ready for installation, slide the insert forward in the housing approximately one thirty-second of an inch ($1/32$ ") and alternately tighten the set screws onto the shaft to the specified torque setting as shown in Table 4.

After bearing installation

Before performing any work on the bearing, lock out the power source and allow the shaft and adjacent machinery to cool down to ambient temperature. Loosen the set screws or other locking mechanism to allow the shaft to move freely within the bore then follow the same procedures explained in the "Before bearing installation" section.

5.3 Installation

- Slide the unit onto the shaft while holding the inner ring of the bearing.

Position the unit on the mounting surface so that the plane of the shaft is perpendicular to the face of the housing, and alternately tighten the mounting bolts to the specified torque as shown in Table 2.

Make sure to use bolts, washers, and nuts of sufficient strength and grade rating for the application.

- Check the final position of the shaft and alternately tighten the set screws of the non-expansion unit onto the shaft to the specified torque setting as shown in Table 3. The set screws in the bearing on the opposite side of the shaft should line up

with the set screws of the bearing that was installed first (See Figure A). Expansion bearings should be installed only after the shaft and adjacent machinery has cooled down to the ambient temperature.

After positioning the expansion unit on the shaft slide the insert to the rearmost position within the housing until it seats against the retaining ring. Then slide the insert forward in the housing approximately one thirty second of an inch ($\frac{1}{32}$ ") and alternately tighten the set screws onto the shaft to the specified torque setting as shown in Table 3. Allowable shaft expansion and expansion calculation data can be found in Table 4 and Formula 1 respectively.

- Once installed, slowly rotate the bearing by hand to confirm that it turns smoothly and without resistance, vibration, or any other abnormalities.

Bolt Size		Tightening Torque		
mm	inch	N-m	in-lbf	ft-lbf
M6	$\frac{1}{4}$	5	43	4
M8	$\frac{5}{16}$	10	92	8
M10	$\frac{3}{8}$	22	196	17
M12	$\frac{1}{2}$	38	334	27
M16	$\frac{5}{8}$	95	840	70
M18	—	139	1231	103
M20	$\frac{3}{4}$	189	1664	139
M22	$\frac{7}{8}$	260	2301	192
M27	1	484	4277	358

Size Code	Set Screw Size	N-m	in-lbf	ft-lbf
XS408	$\frac{5}{16}$ -28 UNF x $\frac{1}{2}$	14.5	128	11
XS409				
XS410	$\frac{3}{8}$ -24 UNF x $\frac{5}{8}$	25.5	226	19
XS411				
XS413				
XS415	$\frac{1}{2}$ -20 UNF x $\frac{3}{4}$	56.5	500	42
XS418				
XS420				

Size Code	mm	inch
XS408	5	$\frac{13}{64}$
XS409	5	$\frac{13}{64}$
XS410	5	$\frac{13}{64}$
XS411	6	$\frac{15}{64}$
XS413	6	$\frac{15}{64}$
XS415	6	$\frac{15}{64}$
XS418	6	$\frac{15}{64}$
XS420	6	$\frac{15}{64}$

$L = A \cdot T \cdot D$ <p>L : Expansion of shaft (mm) A : Linear expansion coefficient of shaft for ordinary steel (11.5×10^{-6}) T : Temperature increase (°C) D : Installation distance between bearing units (mm)</p>
--

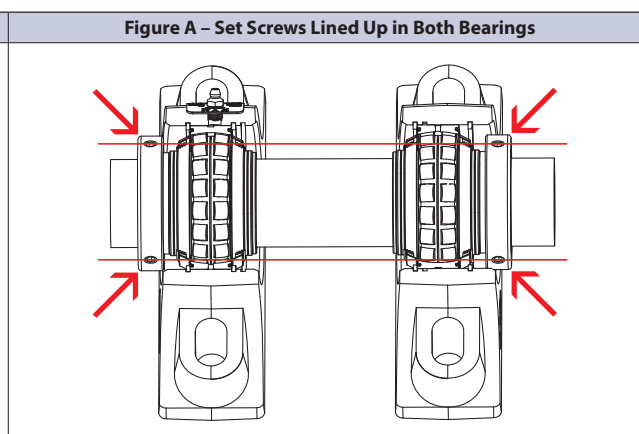

VIDEO ON INSTALLATION



Please scan the QR code with your mobile phone and watch an installation video.

If you don't have the reader, get the QR Reader app at the app store. Or you can find it at our website as well.



5.4 Lubrication

Proper lubrication practices will greatly extend the life of the bearing.

Bearings are factory lubricated with the proper amount and type of lubricant for most general purpose applications as well as many highly demanding operating environments, and except as recommended by FYH, no further lubrication is required upon installation.

Lubrication tips:

- The factory standard lubricant is a **Calcium Sulfonate** grease. Always use the same type of lubricant to avoid compatibility issues and other potential problems.
- When adding lubricant do so slowly and while the bearing is rotating until a small amount of lubricant can be seen coming out of the seals.
- At low speeds (below 200 RPM) it is acceptable to completely fill the bearing with grease.
- At moderate to high speeds it is not advisable to completely fill the bearing with grease as it could lead to overheating and reduced bearing life.
- It is generally better to use less lubrication more frequently than more lubricant less often.
- If the unit will not be operated for an extended period of time extra lubricant should be added to prevent corrosion.
- If the unit has not been operated for an extended period of time fresh lubricant should be added prior to start-up.
- If the unit becomes too hot during operation from over-lubrication remove the grease fitting and operate the unit for approximately thirty minutes to allow excess grease to purge.

Appropriate lubrication intervals can be determined by referring to Table 5; however experience should largely determine the actual lubrication regimen for a particular application. Consult with an FYH representative for assistance.

If a suitable Calcium Sulfonate lubricant is not available for re-lubrication then the following compatible lubricants may also be used:

Barium Complex, Calcium Stearate, Lithium Complex, Polyurea (Shear Stable)

The use of any other type of lubricant should be avoided to prevent compatibility issues with the Calcium Sulfonate grease that is originally supplied.

To find the proper lubrication interval in Table 5 obtain the relevant percentage of max allowable RPM by referring to Table 6. Example: XS41 1 with positive contact seals has a max RPM rating of 2000. If the application has an RPM of 600 then the percentage of max RPM is 30% ($600/2000 = .30$).

The amount of grease for replenishment can be found in Table 7.

Environment	Clean to Moderately Dirty				Clean to Moderately Dirty			Dirty to Very Dirty
Temperature (°C)	Under 120 degrees				Over 120 degrees			From -20 to 200
% of max allowable RPM	0 - 25%	25 - 50%	50 - 75%	75 - 100%	0 - 25%	25 - 50%	50 - 100%	0 - 100%
Lubrication interval	From three to eight months	From one to three months	From one week to one month	Daily to once per week	From two to six weeks	From one week to one month	Daily to once per week	Daily to once per week

Table 6 - Limiting Speed for Seals

Size Code	Standard Triple Lip Seal Limiting	Non Contact Seal Limiting
XS408	2750	3200
XS409	2450	2800
XS410	2200	2600
XS411	2000	2360
XS413	1692	2000
XS415	1460	1730
XS418	1220	1440
XS420	1100	1300

Table 7 - Grease Amount for Replenishment

Size Code	Amount of Grease (grams)
XS408	7-8
XS409	7-9
XS410	8-9
XS411	10-12
XS413	19-22
XS415	22-26
XS418	40-46
XS420	50-59



XS2P
Cylindrical bore
(with set screw collar lock)
 d 1 3/8 ~ 4 inch
40 ~ 100 mm

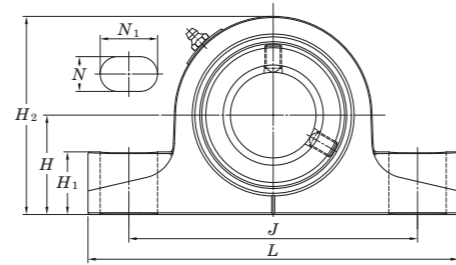
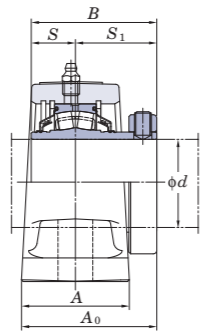

ZS2P
Cylindrical bore
(with Z-Lock)
 d 1 3/8 ~ 4 inch
40 ~ 100 mm

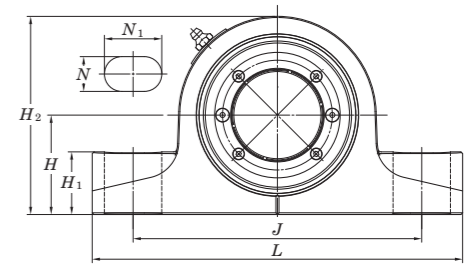
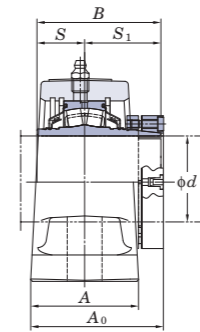

Shaft Dia. inch mm d	Dimensions inch mm												Unit No.	Bearing No.	Unit No.	Bearing No.	Bolt Size inch mm
	H	L	A	J	N	N_1	H_1	H_2	A_0	B	S	S_1					
1 3/8 1 7/16 1 1/2 40	1 7/8 47.6	6 7/8 175	2 5/32 55	5 9/32 134	19/32 15	1 3/32 28	1 1/4 32	3 25/32 96	2 5/8 66.4	2.531	1	1.531	XS2P408-22 XS2P408-23 XS2P408-24 XS2P408	XS408-22 XS408-23 XS408-24 XS408	ZS2P408-22 ZS2P408-23 ZS2P408-24 ZS2P408	ZS408-22 ZS408-23 ZS408-24 ZS408	1/2 M12
1 11/16 1 3/4 45	2 1/8 54	7 3/8 187	2 3/8 60	5 25/32 147	19/32 15	1 3/32 28	1 5/16 33	4 1/4 108	2 27/32 72.1	2.657	1	1.657	XS2P409-27 XS2P409-28 XS2P409	XS409-27 XS409-28 XS409	ZS2P409-27 ZS2P409-28 ZS2P409	ZS409-27 ZS409-28 ZS409	1/2 M12
1 15/16 50 2	2 1/4 57.2	8 3/8 213	2 7/16 62	6 17/32 166	25/32 20	1 5/16 33	1 3/8 35	4 1/2 114	3 1/16 77.8	2.843	1	1.843	XS2P410-31 XS2P410 XS2P410-32	XS410-31 XS410 XS410-32	ZS2P410-31 ZS2P410 ZS2P410-32	ZS410-31 ZS410 ZS410-32	5/8 M16
55 2 3/16 2 1/4	2 1/2 63.5	8 7/8 225	2 5/8 67	6 7/8 175	25/32 20	1 3/16 30	1 5/8 41	4 31/32 126	3 1/8 79.5	2.937	1.126	1.811	XS2P411 XS2P411-35 XS2P411-36	XS411 XS411-35 XS411-36	ZS2P411 ZS2P411-35 ZS2P411-36	ZS411 ZS411-35 ZS411-36	5/8 M16
60 2 7/16 2 1/2 65	2 3/4 69.8	9 1/4 235	2 7/8 73	7 9/32 185	25/32 20	1 3/16 30	1 25/32 45	5 19/32 142	3 3/8 86.1	3.205	1.252	1.953	XS2P412 XS2P413-39 XS2P413-40 XS2P413	XS412 XS413-39 XS413-40 XS413	ZS2P412 ZS2P413-39 ZS2P413-40 ZS2P413	ZS412 ZS413-39 ZS413-40 ZS413	5/8 M16
70 2 11/16 2 3/4 2 15/16 75 3	3 1/4 82.6	10 7/16 265	3 76	8 9/32 210	15/16 24	1 9/32 32	1 7/8 48	6 3/8 162	3 13/16 97	3.594	1.252	2.343	XS2P414 XS2P415-43 XS2P415-44 XS2P415-47 XS2P415 XS2P415-48	XS414 XS415-43 XS415-44 XS415-47 XS415 XS415-48	ZS2P414 ZS2P415-43 ZS2P415-44 ZS2P415-47 ZS2P415 ZS2P415-48	ZS414 ZS415-43 ZS415-44 ZS415-47 ZS415 ZS415-48	3/4 M20
80 3 1/4 85 3 7/16 3 1/2 90	3 3/4 95.2	13 330	3 3/8 86	10 5/16 262	1 1/16 27	1 23/32 44	2 1/4 57	7 15/32 190	4 1/4 108.1	4.079	1.516	2.563	XS2P416 XS2P417-52 XS2P417 XS2P418-55 XS2P418-56 XS2P418	XS416 XS417-52 XS417 XS418-55 XS418-56 XS418	ZS2P416 ZS2P417-52 ZS2P417 ZS2P418-55 ZS2P418-56 ZS2P418	ZS416 ZS417-52 ZS417 ZS418-55 ZS418-56 ZS418	7/8 M22
100 3 15/16 4	4 1/4 108	15 1/4 387	3 3/4 95	11 1/4 286	1 5/32 29	2 5/16 59	2 17/32 64	8 11/32 212	4 23/32 120.1	4.484	1.626	2.858	XS2P420 XS2P420-63 XS2P420-64	XS420 XS420-63 XS420-64	ZS2P420 ZS2P420-63 ZS2P420-64	ZS420 ZS420-63 ZS420-64	1 M27

XSE2P
Cylindrical bore
(with set screw collar lock)
 d 1 3/8 ~ 4 inch
40 ~ 100 mm

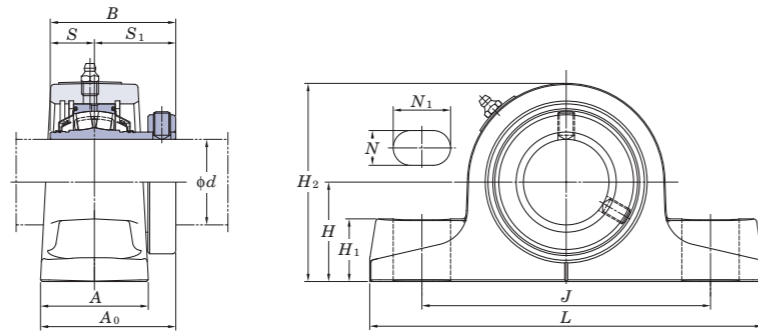

ZSE2P
Cylindrical bore
(with Z-Lock)
 d 1 3/8 ~ 4 inch
40 ~ 100 mm

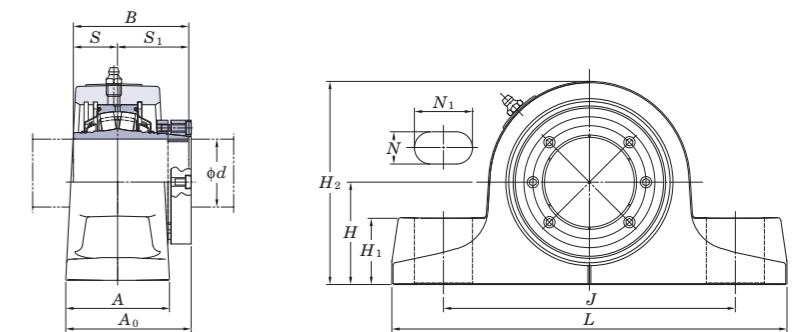

Shaft Dia. inch mm d	Dimensions inch mm												Unit No.	Bearing No.	Unit No.	Bearing No.	Bolt Size inch mm
	H	L	A	J	N	N_1	H_1	H_2	A_0	B	S	S_1					
1 3/8 1 7/16 1 1/2 40	1 7/8 47.6	7 3/8 187	2 5/32 55	5 9/32 134	19/32 15	1 3/32 28	1 1/4 32	3 25/32 96	2 5/8 66.4	2.531	1	1.531 38.9	XSE2P408-22 XSE2P408-23 XSE2P408-24 XSE2P408	XS408-22 XS408-23 XS408-24 XS408	ZSE2P408-22 ZSE2P408-23 ZSE2P408-24 ZSE2P408	ZS408-22 ZS408-23 ZS408-24 ZS408	M12
1 11/16 1 3/4 45	2 1/8 54	7 7/8 200	2 3/8 60	5 25/32 147	19/32 15	1 3/32 28	1 5/16 33	4 1/4 108	2 27/32 72.1	2.657	1	1.657 42.1	XSE2P409-27 XSE2P409-28 XSE2P409	XS409-27 XS409-28 XS409	ZSE2P409-27 ZSE2P409-28 ZSE2P409	ZS409-27 ZS409-28 ZS409	M12
1 15/16 50 2	2 1/4 57.2	8 29/32 226	2 7/16 62	6 17/32 166	25/32 20	1 5/16 33	1 3/8 35	4 1/2 114	3 1/16 77.8	2.843	1	1.843 46.8	XSE2P410-31 XSE2P410 XSE2P410-32	XS410-31 XS410 XS410-32	ZSE2P410-31 ZSE2P410 ZSE2P410-32	ZS410-31 ZS410 ZS410-32	M16
55 2 3/16 2 1/4	2 1/2 63.5	9 21/32 245	2 5/8 67	7 1/8 181	25/32 20	1 13/32 36	1 5/8 41	4 31/32 126	3 1/8 79.5	2.937	1.126	1.811 46	XSE2P411 XSE2P411-35 XSE2P411-36	XS411 XS411-35 XS411-36	ZSE2P411 ZSE2P411-35 ZSE2P411-36	ZS411 ZS411-35 ZS411-36	M16
60 2 7/16 2 1/2 65	2 3/4 69.8	10 1/4 260	2 7/8 73	7 11/16 195	25/32 20	1 9/16 40	1 25/32 45	5 19/32 142	3 3/8 86.1	3.205	1.252	1.953 49.6	XSE2P412 XSE2P413-39 XSE2P413-40 XSE2P413	XS412 XS413-39 XS413-40 XS413	ZSE2P412 ZSE2P413-39 ZSE2P413-40 ZSE2P413	ZS412 ZS413-39 ZS413-40 ZS413	M16
70 2 11/16 2 3/4 2 15/16 75 3	3 1/8 79.5	11 5/8 295	3 76	8 11/16 221	15/16 24	1 11/16 43	1 25/32 45	6 1/4 159	3 13/16 97	3.594	1.252	2.343 59.5	XSE2P414 XSE2P415-43 XSE2P415-44 XSE2P415-47 XSE2P415 XSE2P415-48	XS414 XS415-43 XS415-44 XS415-47 XS415 XS415-48	ZSE2P414 ZSE2P415-43 ZSE2P415-44 ZSE2P415-47 ZSE2P415 ZSE2P415-48	ZS414 ZS415-43 ZS415-44 ZS415-47 ZS415 ZS415-48	M20
80 3 1/4 85 3 7/16 3 1/2 90	3 3/4 95.2	13 1/2 343	3 3/8 86	10 5/16 262	1 1/16 27	1 23/32 44	2 1/4 57	7 15/32 190	4 1/4 108.1	4.079	1.516	2.563 65.1	XSE2P416 XSE2P417-52 XSE2P417 XSE2P418-55 XSE2P418-56 XSE2P418	XS416 XS417-52 XS417 XS418-55 XS418-56 XS418	ZSE2P416 ZSE2P417-52 ZSE2P417 ZSE2P418-55 ZSE2P418-56 ZSE2P418	ZS416 ZS417-52 ZS417 ZS418-55 ZS418-56 ZS418	M22
100 3 15/16 4	4 1/8 104.9	15 1/4 387	3 3/4 95	11 1/4 286	1 5/32 29	2 5/16 59	2 13/32 61	8 7/32 209	4 23/32 120.1	4.484	1.626	2.858 72.6	XSE2P420 XSE2P420-63 XSE2P420-64	XS420 XS420-63 XS420-64	ZSE2P420 ZSE2P420-63 ZSE2P420-64	ZS420 ZS420-63 ZS420-64	M27

XS4F
Cylindrical bore
(with set screw collar lock)
 d 1 3/8 ~ 4 inch
40 ~ 100 mm

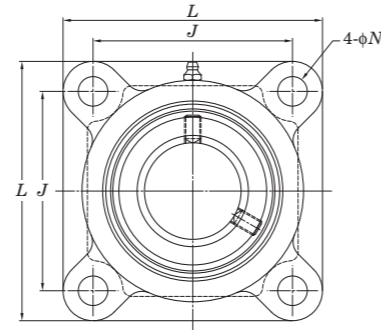
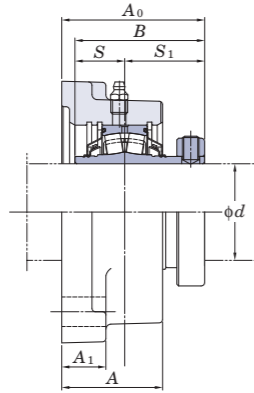

ZS4F
Cylindrical bore
(with Z-Lock)
 d 1 3/8 ~ 4 inch
40 ~ 100 mm

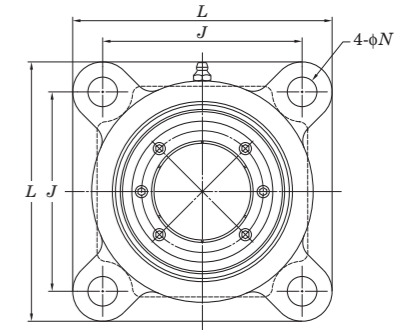
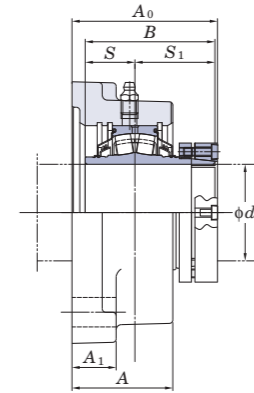

Shaft Dia. inch mm d	Dimensions inch mm										Unit No.	Bearing No.	Unit No.	Bearing No.	Bolt Size inch mm
	L	A	J	N	A_1	A_0	B	S	S_1						
1 3/8 1 7/16 1 1/2 40	4 3/4 121	2 3/32 53	3 17/32 89.7	35/64 14	3/4 19	2 3/4 70.2	2.531 64.3	1 25.4	1.531 38.9		XS4F408-22 XS4F408-23 XS4F408-24 XS4F408	XS408-22 XS408-23 XS408-24 XS408	ZS4F408-22 ZS4F408-23 ZS4F408-24 ZS4F408	ZS408-22 ZS408-23 ZS408-24 ZS408	1/2 M12
1 11/16 1 3/4 45	5 1/8 130	2 5/32 55	3 57/64 98.8	35/64 14	3/4 19	2 31/32 75.4	2.657 67.5	1 25.4	1.657 42.1		XS4F409-27 XS4F409-28 XS4F409	XS409-27 XS409-28 XS409	ZS4F409-27 ZS4F409-28 ZS4F409	ZS409-27 ZS409-28 ZS409	1/2 M12
1 15/16 50 2	5 5/16 135	2 5/32 55	4 1/16 103.2	35/64 14	3/4 19	3 5/32 80.2	2.843 72.2	1 25.4	1.843 46.8		XS4F410-31 XS4F410 XS4F410-32	XS410-31 XS410 XS410-32	ZS4F410-31 ZS4F410 ZS4F410-32	ZS410-31 ZS410 ZS410-32	1/2 M12
55 2 3/16 2 1/4	5 29/32 150	2 9/32 58	4 33/64 114.7	21/32 17	1 1/32 26	3 1/4 82.2	2.937 74.6	1.126 28.6	1.811 46		XS4F411 XS4F411-35 XS4F411-36	XS411 XS411-35 XS411-36	ZS4F411 ZS4F411-35 ZS4F411-36	ZS411 ZS411-35 ZS411-36	5/8 M16
60 2 7/16 2 1/2 65	6 1/8 156	2 9/16 65	4 25/32 121.4	21/32 17	1 1/32 26	3 17/32 89.3	3.205 81.4	1.252 31.8	1.953 49.6		XS4F412 XS4F413-39 XS4F413-40 XS4F413	XS412 XS413-39 XS413-40 XS413	ZS4F412 ZS4F413-39 ZS4F413-40 ZS4F413	ZS412 ZS413-39 ZS413-40 ZS413	5/8 M16
70 2 11/16 2 3/4 2 15/16 75 3	7 7/32 183	2 5/8 67	5 9/16 141.3	7/8 22	1 1/32 26	3 29/32 99.2	3.594 91.3	1.252 31.8	2.343 59.5		XS4F414 XS4F415-43 XS4F415-44 XS4F415-47 XS4F415 XS4F415-48	XS414 XS415-43 XS415-44 XS415-47 XS415 XS415-48	ZS4F414 ZS4F415-43 ZS4F415-44 ZS4F415-47 ZS4F415 ZS4F415-48	ZS414 ZS415-43 ZS415-44 ZS415-47 ZS415 ZS415-48	3/4 M20
80 3 1/4 85 3 7/16 3 1/2 90	8 9/32 210	3 5/32 80	6 23/32 170.7	7/8 22	1 5/32 29	4 3/8 111.5	4.079 103.6	1.516 38.5	2.563 65.1		XS4F416 XS4F417-52 XS4F417 XS4F418-55 XS4F418-56 XS4F418	XS416 XS417-52 XS417 XS418-55 XS418-56 XS418	ZS4F416 ZS4F417-52 ZS4F417 ZS4F418-55 ZS4F418-56 ZS4F418	ZS416 ZS417-52 ZS417 ZS418-55 ZS418-56 ZS418	3/4 M20
100 3 15/16 4	9 1/4 235	3 19/32 91	7 39/64 193.3	63/64 25	1 3/16 30	4 27/32 123	4.484 113.9	1.626 41.3	2.858 72.6		XS4F420 XS4F420-63 XS4F420-64	XS420 XS420-63 XS420-64	ZS4F420 ZS4F420-63 ZS4F420-64	ZS420 ZS420-63 ZS420-64	7/8 M22

XSE4F
Cylindrical bore
(with set screw collar lock)
 d 1 3/8 ~ 4 inch
40 ~ 100 mm

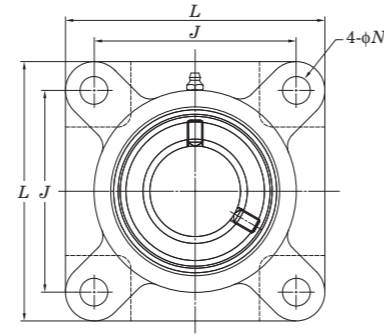
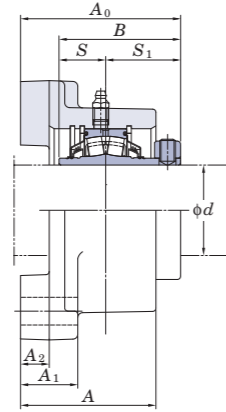

ZSE4F
Cylindrical bore
(with Z-Lock)
 d 1 3/8 ~ 4 inch
40 ~ 100 mm

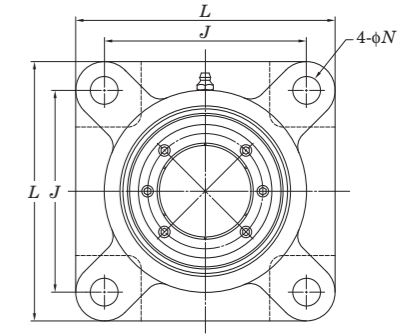
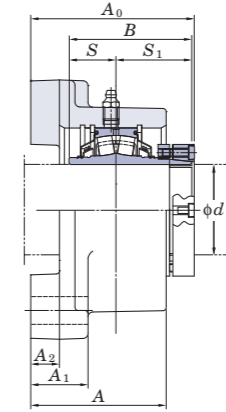

Shaft Dia. inch mm d	Dimensions inch mm										Unit No.	Bearing No.	Unit No.	Bearing No.	Bolt Size inch mm
	L	A	J	N	A_1	A_2	A_0	B	S	S_1					
1 3/8 1 7/16 1 1/2 40	4 19/32 117	2 15/32 63	3 1/2 88.9	35/64 14	1 1/16 27	1/2 13	3 1/16 77.8	2.531 64.3	1 25.4	1.531 38.9	XSE4F408-22 XSE4F408-23 XSE4F408-24 XSE4F408	XS408-22 XS408-23 XS408-24 XS408	ZSE4F408-22 ZSE4F408-23 ZSE4F408-24 ZSE4F408	ZS408-22 ZS408-23 ZS408-24 ZS408	1/2 M12
1 11/16 1 3/4 45	5 11/32 136	2 15/16 75	4 1/8 104.9	35/64 14	1 3/16 30	5/8 16	3 1/2 88.8	2.657 67.5	1 25.4	1.657 42.1	XSE4F409-27 XSE4F409-28 XSE4F409	XS409-27 XS409-28 XS409	ZSE4F409-27 ZSE4F409-28 ZSE4F409	ZS409-27 ZS409-28 ZS409	1/2 M12
1 15/16 50 2	5 5/8 143	2 15/16 75	4 3/8 111	35/64 14	1 3/16 30	5/8 16	3 5/8 92	2.843 72.2	1 25.4	1.843 46.8	XSE4F410-31 XSE4F410 XSE4F410-32	XS410-31 XS410 XS410-32	ZSE4F410-31 ZSE4F410 ZSE4F410-32	ZS410-31 ZS410 ZS410-32	1/2 M12
55 2 3/16 2 1/4	6 1/4 159	3 9/32 83	4 7/8 123.7	21/32 17	1 3/8 35	23/32 18	3 7/8 98.2	2.937 74.6	1.126 28.6	1.811 46	XSE4F411 XSE4F411-35 XSE4F411-36	XS411 XS411-35 XS411-36	ZSE4F411 ZSE4F411-35 ZSE4F411-36	ZS411 ZS411-35 ZS411-36	5/8 M16
60 2 7/16 2 1/2	6 7/8 175	3 11/32 85	5 3/8 136.4	21/32 17	1 1/2 38	25/32 20	4 3/16 106.3	3.205 81.4	1.252 31.8	1.953 49.6	XSE4F412 XSE4F413-39 XSE4F413-40	XS412 XS413-39 XS413-40	ZSE4F412 ZSE4F413-39 ZSE4F413-40	ZS412 ZS413-39 ZS413-40	5/8 M16
65 70 2 11/16 2 3/4 2 15/16	7 3/4 197	3 13/16 97	6 152.4	7/8 22	1 5/8 41	15/16 24	4 11/16 119	3.594 91.3	1.252 31.8	2.343 59.5	XSE4F414 XSE4F415-43 XSE4F415-44 XSE4F415-47	XS414 XS415-43 XS415-44 XS415-47	ZSE4F414 ZSE4F415-43 ZSE4F415-44 ZSE4F415-47	ZS414 ZS415-43 ZS415-44 ZS415-47	3/4 M20
75 3 80 3 1/4	9 1/4 235	4 9/32 109	7 177.8	7/8 22	1 7/8 48	31/32 24.5	5 5/16 135.1	4.079 103.6	1.516 38.5	2.563 65.1	XSE4F415 XSE4F415-48	XS415 XS415-48	ZSE4F415 ZSE4F415-48	ZS415 ZS415-48	
85 3 7/16 3 1/2	9 1/4 235	4 9/32 109	7 177.8	7/8 22	1 7/8 48	31/32 24.5	5 5/16 135.1	4.079 103.6	1.516 38.5	2.563 65.1	XSE4F416 XSE4F417-52 XSE4F417 XSE4F418-55 XSE4F418-56 XSE4F418	XS416 XS417-52 XS417 XS418-55 XS418-56 XS418	ZSE4F416 ZSE4F417-52 ZSE4F417 ZSE4F418-55 ZSE4F418-56 ZSE4F418	ZS416 ZS417-52 ZS417 ZS418-55 ZS418-56 ZS418	
90 100 3 15/16 4	10 1/4 260	5 1/2 140	7 3/4 196.9	63/64 25	2 1/8 54	1 3/32 28	6 1/2 165.2	4.484 113.9	1.626 41.3	2.858 72.6	XSE4F420 XSE4F420-63 XSE4F420-64	XS420 XS420-63 XS420-64	ZSE4F420 ZSE4F420-63 ZSE4F420-64	ZS420 ZS420-63 ZS420-64	7/8 M22

XS4FC
Cylindrical bore
(with set screw collar lock)
 d 1 3/8 ~ 4 inch
40 ~ 100 mm

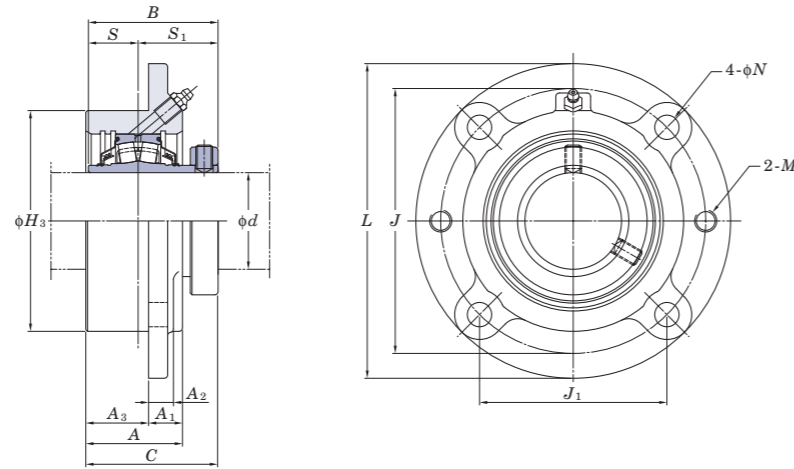

ZS4FC
Cylindrical bore
(with Z-Lock)
 d 1 3/8 ~ 4 inch
40 ~ 100 mm

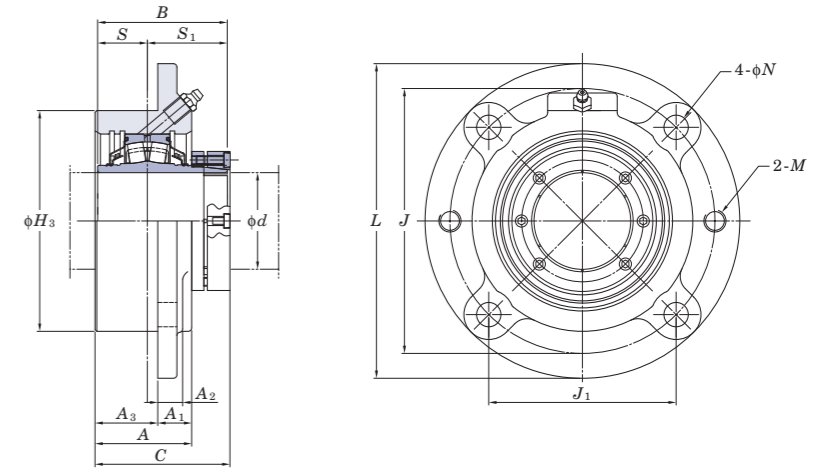

Shaft Dia. inch mm d	Dimensions inch mm														Unit No.	Bearing No.	Unit No.	Bearing No.	Bolt Size inch mm
	L	H_3	J	J_1	N	A	A_1	A_2	A_3	C	M	B	S	S_1					
1 3/8 1 7/16 1 1/2 40	5 1/4 133	3.625 92.1	4 3/8 111.1	3 3/32 78.6	15/32 12	1 27/32 46.8	13/16 21	11/16 17.3	1 1/32 26	2 17/32 64.3		2.531 64.3	1 25.4	1.531 38.9	XS4FC408-22 XS4FC408-23 XS4FC408-24 XS4FC408	XS408-22 XS408-23 XS408-24 XS408	ZS4FC408-22 ZS4FC408-23 ZS4FC408-24 ZS4FC408	ZS408-22 ZS408-23 ZS408-24 ZS408	1/2 M12
1 11/16 1 3/4 45	6 5/32 156	4.25 107.8	5 1/8 130.2	3 5/8 92.1	9/16 14	1 29/32 48.4	5/8 16	1/2 12.7	1 17/64 32.2	2 23/32 69.1		2.657 67.5	1 25.4	1.657 42.1	XS4FC409-27 XS4FC409-28 XS4FC409	XS409-27 XS409-28 XS409	ZS4FC409-27 ZS4FC409-28 ZS4FC409	ZS409-27 ZS409-28 ZS409	1/2 M12
1 15/16 50 2	6 3/8 162	4.5 114.3	5 3/8 136.5	3 51/64 96.5	9/16 14	2 50.8	3/4 19	9/16 14.3	1 17/64 32.2	2 55/64 72.6		2.843 72.2	1 25.4	1.843 46.8	XS4FC410-31 XS4FC410 XS4FC410-32	XS410-31 XS410 XS410-32	ZS4FC410-31 ZS4FC410 ZS4FC410-32	ZS410-31 ZS410 ZS410-32	5/8 M16
55 2 3/16 2 1/4	7 1/8 181	5 127	6 152.4	4 1/4 107.8	35/64 14	2 3/16 55.6	25/32 20	9/16 14.3	1 27/64 36.1	3 76.1		2.937 74.6	1.126 28.6	1.811 46	XS4FC411 XS4FC411-35 XS4FC411-36	XS411 XS411-35 XS411-36	ZS4FC411 ZS4FC411-35 ZS4FC411-36	ZS411 ZS411-35 ZS411-36	5/8 M16
60 2 7/16 2 1/2	7 5/8 194	5.5 139.7	6 1/2 165.1	4 19/32 116.7	35/64 14	2 1/2 63.5	15/16 24	5/8 15.9	1 9/16 39.7	3 7/16 87.4		3.205 81.4	1.252 31.8	1.953 49.6	XS4FC412 XS4FC413-39 XS4FC413-40 XS4FC413	XS412 XS413-39 XS413-40 XS413	ZS4FC412 ZS4FC413-39 ZS4FC413-40 ZS4FC413	ZS412 ZS413-39 ZS413-40 ZS413	5/8 M16
70 2 11/16 2 3/4 2 15/16 75 3	8 3/4 222	6.375 161.9	7 1/2 190.5	5 19/64 134.7	43/64 17	2 5/8 66.7	31/32 25	3/4 19.1	1 5/8 41.3	3 41/64 92.5		3.594 91.3	1.252 31.8	2.343 59.5	XS4FC414 XS4FC415-43 XS4FC415-44 XS4FC415-47 XS4FC415 XS4FC415-48	XS414 XS415-43 XS415-44 XS415-47 XS415 XS415-48	ZS4FC414 ZS4FC415-43 ZS4FC415-44 ZS4FC415-47 ZS4FC415 ZS4FC415-48	ZS414 ZS415-43 ZS415-44 ZS415-47 ZS415 ZS415-48	3/4 M20
80 3 1/4 85 3 7/16 3 1/2 90	10 1/4 260	7.375 187.3	8 5/8 219.1	6 3/32 154.9	29/32 23	3 76.2	1 15/32 38	15/16 23.8	1 33/64 38.5	4 5/32 105.6		4.079 103.6	1.516 38.5	2.563 65.1	XS4FC416 XS4FC417-52 XS4FC417 XS4FC418-55 XS4FC418-56 XS4FC418	XS416 XS417-52 XS417 XS418-55 XS418-56 XS418	ZS4FC416 ZS4FC417-52 ZS4FC417 ZS4FC418-55 ZS4FC418-56 ZS4FC418	ZS416 ZS417-52 ZS417 ZS418-55 ZS418-56 ZS418	7/8 M22
100 3 15/16 4	10 7/8 276	8.125 206.4	9 3/8 238.1	6 5/8 168.4	29/32 23	3 1/2 88.9	1 9/16 40	1 1/4 31.4	1 29/32 48.4	4 9/16 115.9		4.484 113.9	1.626 41.3	2.858 72.6	XS4FC420 XS4FC420-63 XS4FC420-64	XS420 XS420-63 XS420-64	ZS4FC420 ZS4FC420-63 ZS4FC420-64	ZS420 ZS420-63 ZS420-64	1 M27

XST
Cylindrical bore
(with set screw collar lock)
 d 1 15/16 ~ 3 1/2 inch
50 ~ 90 mm

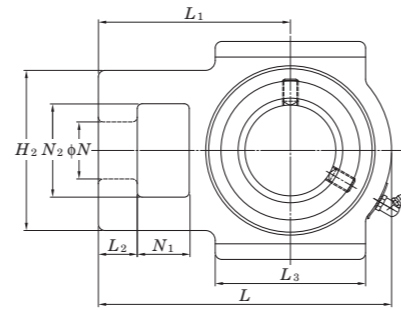
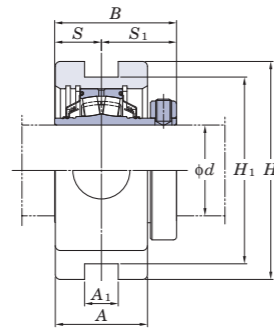

ZST
Cylindrical bore
(with Z-Lock)
 d 1 15/16 ~ 3 1/2 inch
50 ~ 90 mm

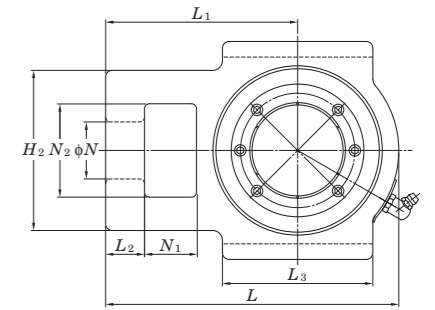
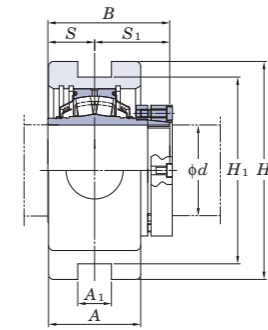

Shaft Dia. inch mm d	Dimensions inch mm															Unit No.	Bearing No.	Unit No.	Bearing No.
	A	A ₁	H	H ₁	H ₂	L	L ₁	L ₂	L ₃	N	N ₁	N ₂	B	S	S ₁				
1 15/16 50 2	2 51	1 1/16 17.5	4 3/4 121	4 101.6	3 5/16 84	6 3/16 157.2	3 15/16 100	1 5/16 23.8	3 5/8 92	1 1/8 28.6	3/4 19.1	1 15/16 49.2	2.843 72.2	1 25.4	1.843 46.8	XST410-31 XST410 XST410-32	XS410-31 XS410 XS410-32	ZST410-31 ZST410 ZST410-32	ZS410-31 ZS410 ZS410-32
55 2 3/16 2 1/4	2 7/32 56	1 3/16 20.6	5 1/4 133	4 1/2 114.3	3 27/32 98	7 1/16 179.4	4 5/8 117.5	1 5/16 23.8	3 5/8 92	1 3/8 34.9	1 1/4 31.8	2 1/4 57.2	2.937 74.6	1.126 28.6	1.811 46	XST411 XST411-35 XST411-36	XS411 XS411-35 XS411-36	ZST411 ZST411-35 ZST411-36	ZS411 ZS411-35 ZS411-36
60 2 7/16 2 1/2 65	2 7/16 62	1 1/16 27	5 7/8 149	5 1/8 130.2	4 1/4 108	7 25/32 198	5 127	1 5/16 23.8	4 3/8 111	1 3/8 34.9	1 1/4 31.8	2 1/2 63.5	3.205 81.4	1.252 31.8	1.953 49.6	XST412 XST413-39 XST413-40 XST413	XS412 XS413-39 XS413-40 XS413	ZST412 ZST413-39 ZST413-40 ZST413	ZS412 ZS413-39 ZS413-40 ZS413
70 2 11/16 2 3/4 2 15/16 75 3	2 11/16 68	1 13/16 46	6 11/16 170	5 15/16 150.8	4 7/8 124	8 7/8 225.4	5 3/4 146.1	1 1/8 28.6	4 1/2 114.3	1 5/8 41.3	1 1/2 38.1	2 3/4 69.9	3.594 91.3	1.252 31.8	2.343 59.5	XST414 XST415-43 XST415-44 XST415-47 XST415 XST415-48	XS414 XS415-43 XS415-44 XS415-47 XS415 XS415-48	ZST414 ZST415-43 ZST415-44 ZST415-47 ZST415 ZST415-48	ZS414 ZS415-43 ZS415-44 ZS415-47 ZS415 ZS415-48
80 3 1/4 85 3 7/16 3 1/2 90	3 1/16 78	1 13/16 46	7 25/32 198	6 13/16 173	5 1/8 130	10 1/16 255.6	6 3/8 161.9	1 1/16 27	5 1/2 139.7	1 7/8 47.6	1 5/8 41.3	2 7/8 73	4.079 103.6	1.516 38.5	2.563 65.1	XST416 XST417-52 XST417 XST418-55 XST418-56 XST418	XS416 XS417-52 XS417 XS418-55 XS418-56 XS418	ZST416 ZST417-52 ZST417 ZST418-55 ZST418-56 ZST418	ZS416 ZS417-52 ZS417 ZS418-55 ZS418-56 ZS418

XS4P
Cylindrical bore
(with set screw collar lock)
 d 2 7/16 ~ 4 inch
60 ~ 100 mm

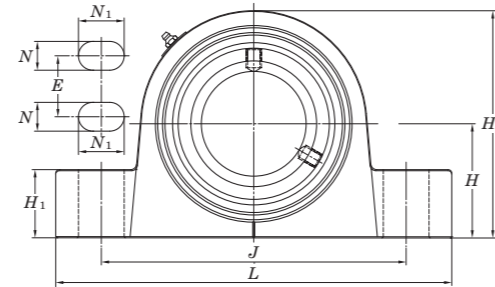
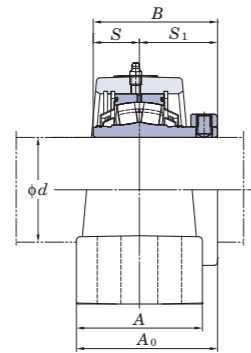
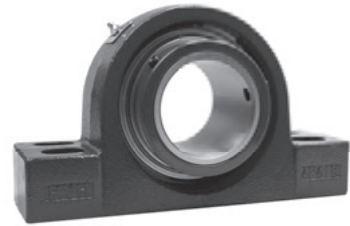

ZS4P
Cylindrical bore
(with Z-Lock)
 d 2 7/16 ~ 4 inch
60 ~ 100 mm

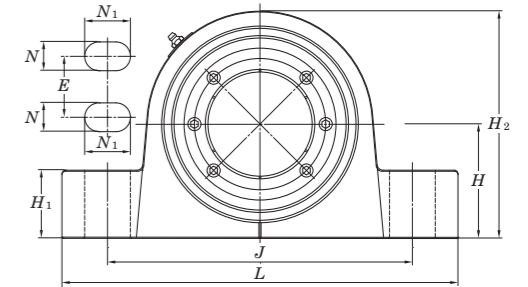
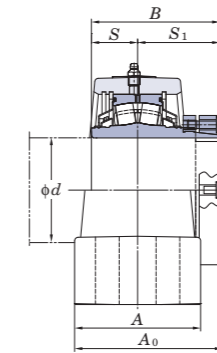

Shaft Dia. inch mm d	Dimensions inch mm														Unit No.	Bearing No.	Unit No.	Bearing No.	Bolt Size inch mm
	H	L	A	J	N	N_1	E	H_1	H_2	A_0	B	S	S_1						
60 2 7/16 2 1/2	2 3/4 69.8	9 1/4 235	3 3/8 86	7 1/8 181	19/32 15	13/16 21	1 3/4 44	1 5/8 41	5 19/32 142	3 21/32 92.6	3.205 81.4	1.252 31.8	1.953 49.6	XS4P412 XS4P413-39 XS4P413-40 XS4P413	XS412 XS413-39 XS413-40 XS413	ZS4P412 ZS4P413-39 ZS4P413-40 ZS4P413	ZS412 ZS413-39 ZS413-40 ZS413	1/2 M12	
65 70 2 11/16 2 3/4 2 15/16	3 1/4 82.6	10 7/16 265	3 3/4 95	8 1/8 206	25/32 20	15/16 24	1 7/8 48	1 7/8 48	6 3/8 162	4 7/32 107	3.594 91.3	1.252 31.8	2.343 59.5	XS4P414 XS4P415-43 XS4P415-44 XS4P415-47 XS4P415 XS4P415-48	XS414 XS415-43 XS415-44 XS415-47 XS415 XS415-48	ZS4P414 ZS4P415-43 ZS4P415-44 ZS4P415-47 ZS4P415 ZS4P415-48	ZS414 ZS415-43 ZS415-44 ZS415-47 ZS415 ZS415-48	5/8 M16	
80 3 1/4	3 3/4	13	4 1/8	10	15/16	1 1/2	2	2 1/4	7 9/16	4 5/8	4.079	1.516	2.563	XS4P416 XS4P417-52 XS4P417	XS416 XS417-52 XS417	ZS4P416 ZS4P417-52 ZS4P417	ZS416 ZS417-52 ZS417	3/4 M20	
85 3 7/16 3 1/2	95.2	330	105	254	24	38	50.8	57	192	117.6	103.6	38.5	65.1	XS4P418-55 XS4P418-56 XS4P418	XS418-55 XS418-56 XS418	ZS4P418-55 ZS4P418-56 ZS4P418	ZS418-55 ZS418-56 ZS418		
90 100 3 15/16 4	4 1/4 108	15 1/4 387	4 1/2 114	12 1/2 318	15/16 24	1 17/32 39	2 1/4 57	2 7/16 62	8 3/8 213	5 3/32 129.6	4.484 113.9	1.626 41.3	2.858 72.6	XS4P420 XS4P420-63 XS4P420-64	XS420 XS420-63 XS420-64	ZS4P420 ZS4P420-63 ZS4P420-64	ZS420 ZS420-63 ZS420-64	3/4 M20	

XDS4P
Cylindrical bore
(with set screw collar lock)
 d 2 7/16 ~ 4 inch
60 ~ 100 mm

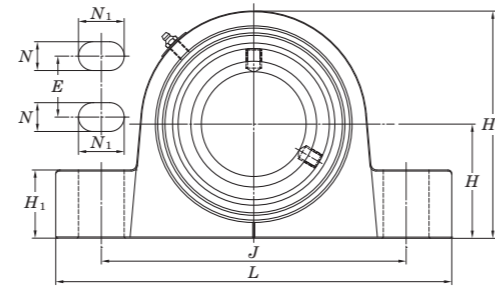
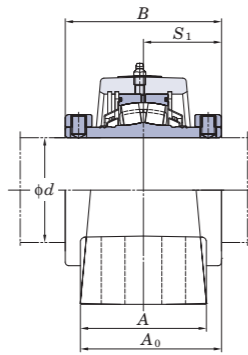

ZDS4P
Cylindrical bore
(with Z-Lock)
 d 2 7/16 ~ 4 inch
60 ~ 100 mm

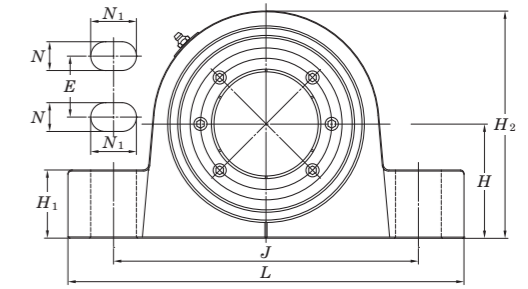
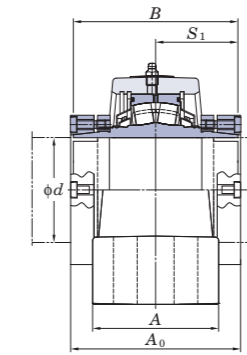

Shaft Dia. inch mm d	Dimensions inch mm												Unit No.	Bearing No.	Unit No.	Bearing No.	Bolt Size inch mm
	H	L	A	J	N	N_1	E	H_1	H_2	A_0	B	S_1					
60 2 7/16 2 1/2	2 3/4 69.8	9 1/4 235	3 3/8 86	7 1/8 181	19/32 15	13/16 21	1 3/4 44	1 5/8 41	5 19/32 142	3 21/32 92.6	3.906 99.2	1.953 49.6	XDS4P412 XDS4P413-39 XDS4P413-40 XDS4P413	XDS412 XDS413-39 XDS413-40 XDS413	ZDS4P412 ZDS4P413-39 ZDS4P413-40 ZDS4P413	ZDS412 ZDS413-39 ZDS413-40 ZDS413	1/2 M12
65 70 2 11/16 2 3/4 2 15/16	3 1/4 82.6	10 7/16 265	3 3/4 95	8 1/8 206	25/32 20	15/16 24	1 7/8 48	1 7/8 48	6 3/8 162	4 7/32 107	4.686 119	2.343 59.5	XDS4P414 XDS4P415-43 XDS4P415-44 XDS4P415-47 XDS4P415 XDS4P415-48	XDS414 XDS415-43 XDS415-44 XDS415-47 XDS415 XDS415-48	ZDS4P414 ZDS4P415-43 ZDS4P415-44 ZDS4P415-47 ZDS4P415 ZDS4P415-48	ZDS414 ZDS415-43 ZDS415-44 ZDS415-47 ZDS415 ZDS415-48	5/8 M16
80 3 1/4 85 3 7/16 3 1/2	3 3/4 95.2	13 330	4 1/8 105	10 254	15/16 24	1 1/2 38	2 50.8	2 1/4 57	7 9/16 192	4 5/8 117.6	5.126 130.2	2.563 65.1	XDS4P416 XDS4P417-52 XDS4P417 XDS4P418-55 XDS4P418-56 XDS4P418 XDS4P420 XDS4P420-63 XDS4P420-64	XDS416 XDS417-52 XDS417 XDS418-55 XDS418-56 XDS418 XDS420 XDS420-63 XDS420-64	ZDS4P416 ZDS4P417-52 ZDS4P417 ZDS4P418-55 ZDS4P418-56 ZDS4P418 ZDS4P420 ZDS4P420-63 ZDS4P420-64	ZDS416 ZDS417-52 ZDS417 ZDS418-55 ZDS418-56 ZDS418 ZDS420 ZDS420-63 ZDS420-64	3/4 M20
90 100 3 15/16 4	4 1/4 108	15 1/4 387	4 1/2 114	12 1/2 318	15/16 24	1 17/32 39	2 1/4 57	2 7/16 62	8 3/8 213	5 3/32 129.6	5.716 145.2	2.858 72.6	XDS4P420 XDS4P420-63 XDS4P420-64	XDS420 XDS420-63 XDS420-64	ZDS4P420 ZDS4P420-63 ZDS4P420-64	ZDS420 ZDS420-63 ZDS420-64	3/4 M20

XS4
Cylindrical bore
(with set screw collar lock)
 d 1 ³/₈ ~ 4 inch
40 ~ 100 mm

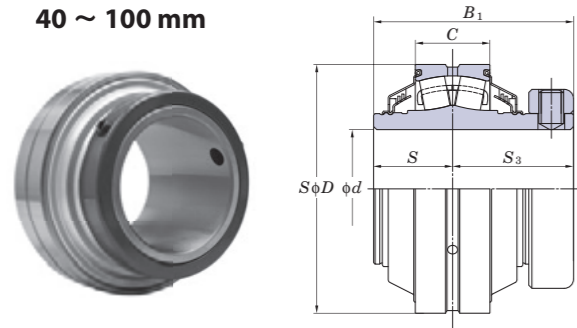

ZS4
Cylindrical bore
(with Z-Lock)

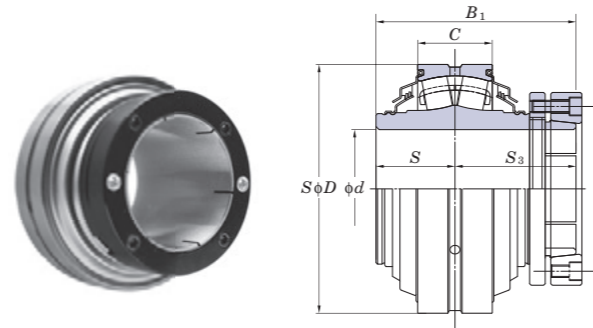

Shaft Dia. inch mm d	Dimensions inch mm					Bearing No.	Bearing No.
	C	D	B_1	S	S_3		
1 ³ / ₈ 1 ⁷ / ₁₆ 1 ¹ / ₂ 40	¹⁵ / ₁₆ 24	3 ⁵ / ₃₂ 80	2.531 64.3	1 25.4	1.531 38.9	XS408-22 XS408-23 XS408-24 XS408	ZS408-22 ZS408-23 ZS408-24 ZS408
1 ¹¹ / ₁₆ 1 ³ / ₄ 45	¹⁵ / ₁₆ 24	3 ¹¹ / ₃₂ 85	2.657 67.5	1 25.4	1.657 42.1	XS409-27 XS409-28 XS409	ZS409-27 ZS409-28 ZS409
1 ¹⁵ / ₁₆ 50 2	¹⁵ / ₁₆ 24	3 ¹⁷ / ₃₂ 90	2.843 72.2	1 25.4	1.843 46.8	XS410-31 XS410 XS410-32	ZS410-31 ZS410 ZS410-32
55 2 ³ / ₁₆ 2 ¹ / ₄	1 ¹ / ₃₂ 26	3 ¹⁵ / ₁₆ 100	2.937 74.6	1.126 28.6	1.811 46	XS411 XS411-35 XS411-36	ZS411 ZS411-35 ZS411-36
60 2 ⁷ / ₁₆ 2 ¹ / ₂	1 ¹ / ₄ 32	4 ²³ / ₃₂ 120	3.205 81.4	1.252 31.8	1.953 49.6	XS412 XS413-39 XS413-40 XS413	ZS412 ZS413-39 ZS413-40 ZS413
70 2 ¹¹ / ₁₆ 2 ³ / ₄ 2 ¹⁵ / ₁₆	1 ¹ / ₄ 32	5 ¹ / ₈ 130	3.594 91.3	1.252 31.8	2.343 59.5	XS414 XS415-43 XS415-44 XS415-47 XS415 XS415-48	ZS414 ZS415-43 ZS415-44 ZS415-47 ZS415 ZS415-48
75 3							
80 3 ¹ / ₄							
85 3 ⁷ / ₁₆ 3 ¹ / ₂	1 ⁵ / ₈ 41	6 ⁵ / ₁₆ 160	4.079 103.6	1.516 38.5	2.563 65.1	XS416 XS417 XS418-55 XS418-56 XS418	ZS416 ZS417 ZS418-55 ZS418-56 ZS418
90							
100 3 ¹⁵ / ₁₆ 4	1 ²⁷ / ₃₂ 47	7 ³ / ₃₂ 180	4.484 113.9	1.626 41.3	2.858 72.6	XS420 XS420-63 XS420-64	ZS420 ZS420-63 ZS420-64

XDS4
Cylindrical bore
(with set screw collar lock (both))
 d 2 ⁷/₁₆ ~ 4 inch
60 ~ 100 mm

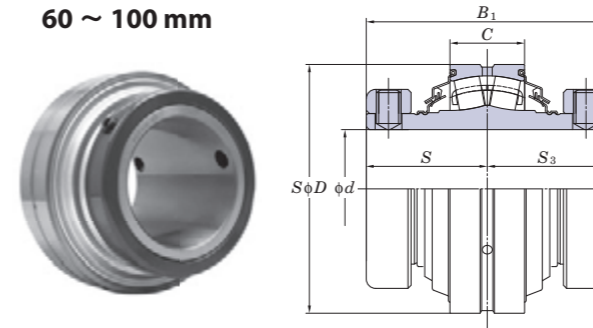

ZDS4
Cylindrical bore
(with Z-Lock (both))

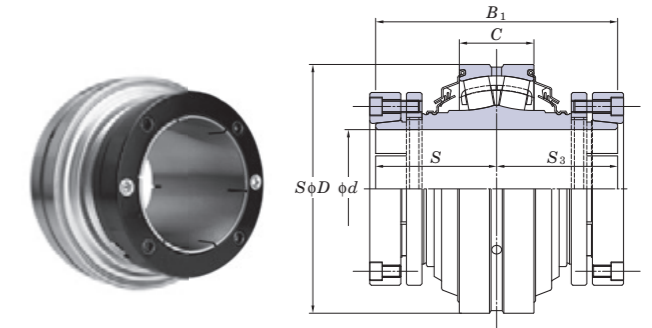



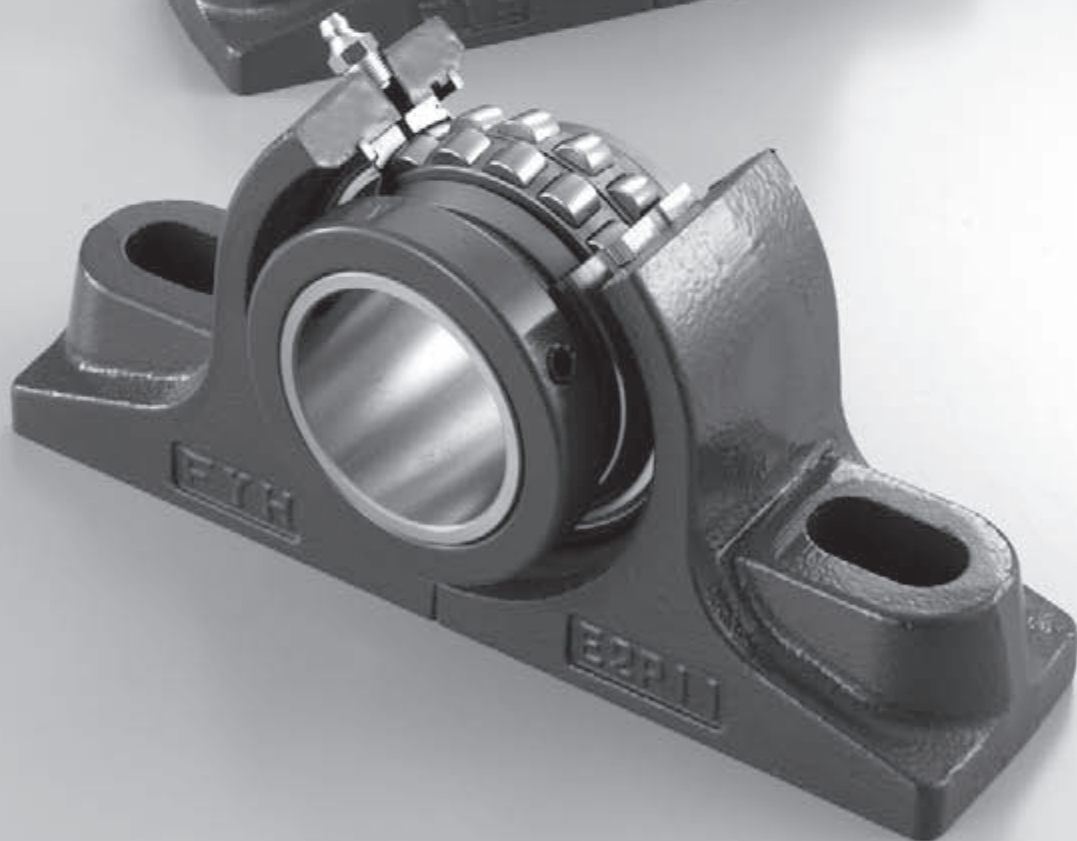





Shaft Dia. inch mm d	Dimensions inch mm					Bearing No.	Bearing No.
	C	D	B_1	S	S_3		
60 2 ⁷ / ₁₆ 2 ¹ / ₂	1 ¹ / ₄ 32	4 ²³ / ₃₂ 120	3.905 99.2	1.953 49.6	1.953 49.6	XDS412 XDS413-39 XDS413-40 XDS413	ZDS412 ZDS413-39 ZDS413-40 ZDS413
65							
70 2 ¹¹ / ₁₆ 2 ³ / ₄ 2 ¹⁵ / ₁₆	1 ¹ / ₄ 32	5 ¹ / ₈ 130	4.685 119	2.343 59.5	2.343 59.5	XDS414 XDS415-43 XDS415-44 XDS415-47 XDS415 XDS415-48	ZDS414 ZDS415-43 ZDS415-44 ZDS415-47 ZDS415 ZDS415-48
75 3							
80 3 ¹ / ₄							
85 3 ⁷ / ₁₆ 3 ¹ / ₂	1 ⁵ / ₈ 41	6 ⁵ / ₁₆ 160	5.126 130.2	2.563 65.1	2.563 65.1	XDS416 XDS417 XDS418-55 XDS418-56 XDS418	ZDS416 ZDS417 ZDS418-55 ZDS418-56 ZDS418
90							
100 3 ¹⁵ / ₁₆ 4	1 ²⁷ / ₃₂ 47	7 ³ / ₃₂ 180	5.716 145.2	2.858 72.6	2.858 72.6	XDS420 XDS420-63 XDS420-64	ZDS420 ZDS420-63 ZDS420-64



Appendix Table (contents)

1	Simplified Chart of Ball Bearing Unit Combinations	358
2	Tightening Torques of Housings and Cast Iron Cover Mounting Bolts.....	360
3	Tightening Torques of Inner Rings and Eccentric Locking Collar Set Screws...	360
4	Tightening Torques of Adapter Lock Nuts (reference)	361
5	Machining Dimensions of Holes of Housing Dowel Pins	362
6	Dimensional Tolerances of Shafts.....	364
7	Dimensional Tolerances of Housing Bores	366
8	Basic Tolerance Values	368
9	SI Unit Conversion Charts	369
10	Inch-meter Conversion Chart.....	370
11	Hardness Conversion Chart	371
12	Viscosity Conversion Chart.....	372
13	Mechanical Properties of Metal Materials (reference)	373
14	Hexagon Socket Head Cap Screws (abstract from JIS B 1176).....	374
15	Hexagon Head Bolts (abstract from JIS B 1180)	376
16	Hexagon Head Nuts (abstract from JIS B 1181).....	378
17	Ball Bearing Units Interchange Guide.....	379
18	Spherical Roller Bearing Units Interchange Guide	381

Appendix Table 1 Simplified Chart of Ball Bearing Unit Combinations

Type	Housing for units	Insert bearing units								
		Cylindrical bore (with set screws)					Tapered bore (with adapter)			
		UC200	UCX00	UC300	Stainless steel UC200S6	Plated UC200S7	UK200	UKX00	UK300	
 Pillow type	P200, PX00, P300, P300E PK200 P200H4, PX00H4, P300H4	UCP200	UCPX00	UCP300			UKP200	UKPX200	UKP300	
	IP200, IP300 IP200H4, IP300H4	UCIP200	UCIP300				UKIP200	UKIP300		
	PA200 PA200H4	UCPA200					UKPA200			
	PAN200 PH200	UCPAN200					UKPH200			
	PH200H4	UCPH200H4					UKPH200H4			
	LP200									
	SP200H1 SPA200H1				UCSP200H1S6 UCSPA200H1S6					
	P000, SP000									
	VP200 VP200E				UCVP200S6	UCVP200ES7				
	PP200									
	 Square four-bolt flange type	F200, FX00, F300 F200E, FX00E	UCF200	UCFX00	UCF300			UKF200	UKFX00	UKF300
		NF200 F200H4, FX00H4, F300H4	UCF200E	UCFX00E				UKF200H4	UKFX00H4	UKF300H4
		FS300 FS300H4			UCF300H4					UKF300H4
		SF200H1 SF200EH1			UCF300H4					UKF300H4
VF200 VF200E				UCF300H4					UKF300H4	
				UCF300H4					UKF300H4	
				UCF300H4					UKF300H4	
 Oval flange type	FL200, FLX00, FL300 FL200E	UCFL200	UCFLX00	UCFL300			UKFL200	UKFLX00	UKFL300	
	FL200H4, FLX00H4, FL300H4	UCFL200E	UCFLX00E				UKFL200H4	UKFLX00H4	UKFL300H4	
	LF200									
	FL000, SFL000 SFL200H1									
	SFL200EH1 VFL200				UCSFL200H1S6 UCSFL200EH1S6 UCVFL200S6					
	VFL200E					UCVFL200ES7				
	TFD200H4									
	FA200	UCFA200					UKFA200			
	FB200	UCFB200					UKFB200			
	PFL200									
	 Round flange cartridge type	FC200, FCX00 FC200H4, FCX00H4	UCFC200	UCFCX00				UKFC200	UKFCX00	
FCX00E FCF200		UCFC200H4	UCFCX00H4				UKFC200H4	UKFCX00H4		
SFC200H1		UCFCF200	UCFCX00E							
					UCSFC200H1S6					
 Stamped steel plate flange type	PF200									
 Take-up type	T200, TX00, T300 T200E, TX00E	UCT200	UCTX00	UCT300			UKT200	UKTX00	UKT300	
	T200H4, TX00H4, T300H4	UCT200E	UCTX00E				UKT200H4	UKTX00H4	UKT300H4	
	ST200H1 VT200	UCT200H4	UCTX00H4	UCT300H4						
	VT200E				UCST200H1S6 UCVT200S6					
	T200+H					UCVT200ES7				
	TL200 TU200, TU300	UCTH200					(UKTL200) (UKTU200)		(UKTU300)	
	PTH200 NPTH200	UCTL200 UCTU200		UCTU300						
 Cartridge type	C200, CX00, C300	UCC200	UCCX00	UCC300			UKC200	UKCX00	UKC300	
 Hanger type	HA200	UCHA200					UKHA200			

Insert bearing units									Housing for units	Type
Cylindrical bore										
NU-LOC 	with set screws 			with eccentric locking collar 						
NC200	SU000	Stainless steel SU000S6	SB200	SA200	SA200F	NA200	NA300			
NCP200						NAP200 NAPK200	NAP300E	P200, PX00, P300, P300E PK200 P200H4, PX00H4, P300H4	Pillow type 	
								IP200, IP300 IP200H4, IP300H4		
NCPA200								PA200 PA200H4	Square four-bolt flange type 	
NCPAN200								PAN200		
NCPH200								PH200		
				BLP200	ALP200			PH200H4		
								LP200		
	UP000	USP000S6						SP200H1 SPA200H1 P000, SP000		
								VP200 VP200E		
				SBPP200	SAPP200			PP200		
NCF200 NCF200E						NAF200 NANF200		F200, FX00, F300 F200E, FX00E NF200 F200H4, FX00H4, F300H4		
								FS300 FS300H4		
								SF200H1 SF200EH1 VF200 VF200E		
NCFL200 NCFL200E						NAFL200		FL200, FLX00, FL300 FL200E FL200H4, FLX00H4, FL300H4	Oval flange type 	
				BLF200	ALF200			LF200		
	UFL000	USFL000S6						FL000, SFL000 SFL200H1 SFL200EH1 VFL200 VFL200E		
							SATFD200FH4P9	TFD200H4		
NCFA200								FA200		
NCFB200								FB200		
				SBPFL200	SAPFL200			PFL200		
NCFC200						NAFC200		FC200, FCX00 FC200H4, FCX00H4 FCX00E FCF200 SFC200H1	Round flange cartridge type 	
				SBPF200	SAPF200			PF200	Stamped steel plate flange type 	
NCT200 NCT200E						NAT200 NAT200E		T200, TX00, T300 T200E, TX00E T200H4, TX00H4, T300H4	Take-up type 	
								ST200H1 VT200 VT200E		
								T200+H		
								TL200 TU200, TU300		
				SBPTH200 SBNPTH200				PTH200 NPTH200		
NCC200						NAC200		C200, CX00, C300	Cartridge type 	
NCHA200								HA200	Hanger type 	

Appendix Table 2 Tightening Torques of Housings and Cast Iron Cover Mounting Bolts

(1) Tightening torques of housings mounting bolts (recommended)

Nominal size of screws	Tightening torques N · m
M 6	2.6– 4.7
M 8	6 – 10
M10	12 – 21
M12	21 – 37
M14	34 – 60
M16	53 – 93
M18	77 – 137
M20	104 – 186
M22	143 – 256
M27	266 – 478
M30	360 – 645
M33	494 – 886
M36	631 – 1,130

(2) Tightening torques of plastic housings mounting bolts (recommended)

Nominal size of screws	Tightening torques N · m
M10	17.7–24.5
M12	29.4–44.1

(3) Tightening torques of cast iron cover mounting bolts (recommended)

Nominal size of screws	Tightening torques, N · m	Part No. of applicable cast iron covers (reference)		
		200 series	X00 series	300 series
M3	0.3– 0.6	204, 205	–	–
M4	0.8– 1.4	204FC3 (FD3), 205FC3 (FD3), 206–215	–	305–307
M5	1.5– 2.8	216–218	X18, X20	308–324
M8	6 –10	–	–	326, 328

Appendix Table 3 Tightening Torques of Inner Rings and Eccentric Locking Collar Set Screws

(1) Tightening torques of inner rings and eccentric locking collar set screws (metric series) (recommended)

Nominal size of screws	Tightening torques, N · m	Part No. of applicable bearings						
		UC2, RB	UCX	UC3	NA	SB	SU	ER
M 3X0.35	0.7						08, 000, 001	
M 4X0.5	1.8	–				–	002, 003	
M 5X0.5	3	201X–203X	–	–		201–203	004–006	–
M 6X0.75	4	201–206	X05	305, 306	204, 205	204–207	–	201–206
M 8X1	8.5	207–209	X06–X08	307	206–210	208		207–209
M10X1.25	17.5	210–212	X09–X11	308, 309	211, 212	–		210–212
M12X1.5	28	213–218	X12–X17	310–314	–			–
M14X1.5	35	–	X18	315, 316				
M16X1.5	56		X20	317–319				
M18X1.5	62		–	320–324				
M20X1.5	83			326, 328				

Remarks 1) Tightening torques of set screws for UC2-S6 are identical to that of UC2. As for UC210S6, tightening torque of the set screw M8 × 1 should be applied.

2) When the application will be exposed to vibration and shock load additional tightening will be required. The maximum torque tightening should not exceed 1.5 times the normal torque tightening specifications.

(2) Tightening torques of inner rings and eccentric locking collar set screws (inch series) (recommended)

Nominal size of screws	Tightening torques, N · m	Part No. of applicable bearings		
		UC2-, ER2-, RB2-	UCX-	SB-
10-32UNF	3	–	–	201, 202
1/4-28UNF	4	201–206	X05	204–207
5/16-24UNF	8.5	207–209	X06–X08	208
3/8-24UNF	17.5	210–212	X09–X11	–
1/2-20UNF	28	213–218	X12–X18	
5/8-18UNF	56	–	X20	

Remark When the application will be exposed to vibration and shock load additional tightening will be required. The maximum torque tightening should not exceed 1.5 times the normal torque tightening specifications.

(3) NC concentric cap screw tightening torque

Nominal size of screws	Tightening torques, N · m
M4	7.4– 8.2
M5	10.2–11.2
M6	17.6–19.4
M8	41.6–46
No.8-32UNC	7.4– 8.2
No.10-24UNC	10.2–11.2
1/4-20UNC	17.6–19.4
5/16-18UNC	41.6–46

Remark When the application will be exposed to vibration and shock load additional tightening will be required. The maximum torque tightening should not exceed 1.5 times the normal torque tightening specifications.

Appendix Table 4 Tightening Torques of Adapter Lock Nuts (reference)

Bore code	Tightening torques, N · m								
	UK200			UKX00			UK300		
	Standard load		Heavy load (Max. × 1.5)	Standard load		Heavy load (Max. × 1.5)	Standard load		Heavy load (Max. × 1.5)
	min.	Max.		min.	Max.		min.	Max.	
05	25	38	56	35	53	79	30	45	68
06	30	45	68	40	60	90	45	68	101
07	40	60	90	50	75	113	60	90	135
08	50	75	113	75	113	169	80	120	180
09	60	90	135	75	113	169	120	180	270
10	75	113	169	110	165	248	150	225	338
11	100	150	225	140	210	315	180	270	405
12	130	195	293	165	248	371	225	338	506
13	150	225	338	195	293	439	265	398	596
15	170	255	383	215	323	484	375	563	844
16	200	300	450	255	383	574	450	675	1,013
17	220	330	495	295	443	664	530	795	1,193
18	260	390	585	340	510	765	610	915	1,373
19	–	–	–	–	–	–	710	1,065	1,598
20	–	–	–	490	735	1,103	885	1,328	1,991
22	–	–	–	–	–	–	1,220	1,830	2,745
24	–	–	–	–	–	–	1,470	2,205	3,308
26	–	–	–	–	–	–	1,770	2,655	3,983
28	–	–	–	–	–	–	2,150	3,225	4,838

Appendix Table 5 Machining Dimensions of Holes of Housing Dowel Pins

(1) Machining dimensions of holes of pillow type housing (P) dowel pins (recommended)

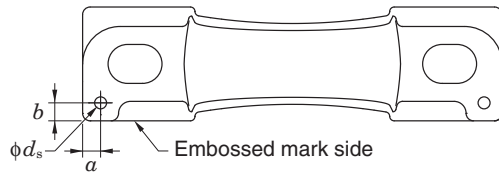

Unit: mm

Nominal code	a	b	d _s (reference)	Pin seat thickness
P203	6	6	4	16
P204	6	6	4	16
P205	6	6	4	16
P206	6	6	4	17
P207	8	8	5	18
P208	8	8	5	18
P209	8	8	5	20
P210	10	10	5	21
P211	10	10	6	23
P212	10	10	6	25
P213	10	10	6	27
P214	10	10	8	27
P215	12.5	12.5	8	28
P216	12	12	8	30
P217	12	12	8	32
P218	14	14	8	33
PX05	7	7	5	16
PX06	8	8	5	17
PX07	8	8	5	19
PX08	8	8	5	21
PX09	8	8	5	21
PX10	9	9	6	22
PX11	9	9	6	28
PX12	9	9	6	28
PX13	10	10	8	28
PX14	10	10	8	32
PX15	10	10	8	32
PX16	12	12	8	34
PX17	12	12	8	34
PX18	15	15	10	38
PX20	19	19	10	45
P305	8	8	5	16
P306	10	10	5	17
P307	10	10	5	19
P308	11	11	6	19
P309	11	11	6	21
P310	11	11	6	24
P311	12	12	8	27
P312	12	12	8	29
P313	12	12	8	32
P314	12	12	10	35
P315	14	14	10	35
P316	15	15	10	35
P317	15	15	10	40
P318	15	15	10	40
P319	15	15	10	46
P320	17	17	13	46
P321	17	17	13	46
P322	17	17	13	50
P324	17	17	13	50
P326	20	20	13	50
P328	20	20	13	60

(2) Machining dimensions of holes of square flange type housing (F) dowel pins (recommended)

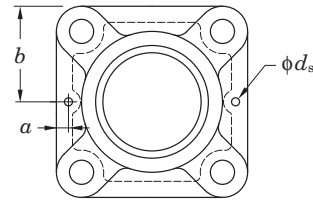

Unit: mm

Nominal code	a	b	d _s (reference)	Pin seat thickness
F204	6	43	4	11
F205	6	47.5	4	13
F206	7.5	54	4	13
F207	7.5	58.5	5	15
F208	7.5	65	5	15
F209	7.5	68.5	5	16
F210	7.5	71.5	5	16
F211	9	81	6	18
F212	9	87.5	6	18
F213	9	93.5	6	22
F214	10	96.5	8	22
F215	10	100	8	22
F216	10	104	8	22
F217	10	110	8	24
F218	10	117.5	8	25
FX05	7.5	54	5	13
FX06	7.5	58.5	5	14
FX07	7.5	65	5	14
FX08	7.5	68.5	5	14
FX09	7.5	71.5	5	14
FX10	9	81	6	20
FX11	9	87.5	6	20
FX12	9	93.5	6	21
FX13	10	93.5	8	21
FX14	10	98.5	8	22
FX15	10	142	8	24
FX16	10	107	8	24
FX17	10	155	8	24
FX18	12	155	10	24
FX20	12	134	10	28
F305	7.5	55	5	13
F306	7.5	62.5	5	15
F307	7.5	67.5	5	16
F308	9	75	6	17
F309	9	80	6	18
F310	9	87.5	6	19
F311	10	92.5	8	20
F312	10	97.5	8	22
F313	10	104	8	22
F314	12	113	10	25
F315	12	118	10	25
F316	12	125	10	27
F317	12	130	10	27
F318	12	140	10	30
F319	12	145	10	30
F320	16	155	13	32
F321	16	155	13	32
F322	16	170	13	35
F324	16	185	13	40
F326	16	205	13	45
F328	16	225	13	55

(3) Machining dimensions of holes of oval flange type housing (FL) dowel pins (recommended)

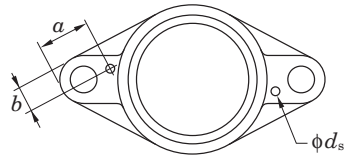

Unit: mm

Nominal code	a	b	d_s (reference)	Pin seat thickness
FL204	26	9	4	11
FL205	32	10	4	13
FL206	34	12	4	13
FL207	34	14	5	14
FL208	35	15	5	14
FL209	40	15	5	15
FL210	41	16	5	15
FL211	43	19	6	18
FL212	52	22	6	18
FL213	50	21	6	20
FL214	52	22	8	20
FL215	53	23	8	20
FL216	56	23	8	20
FL217	57	25	8	22
FL218	57	26	8	23
FLX05	27	12	5	13
FLX06	30	14	5	14
FLX07	32	15	5	14
FLX08	33	15	5	14
FLX09	35	16	5	14
FLX10	37	19	6	20
FL305	32	12	5	13
FL306	46	14	5	15
FL307	44	14	5	16
FL308	45	17	6	17
FL309	53	19	6	18
FL310	53	19	6	19
FL311	52	20	8	20
FL312	60	21	8	22
FL313	60	25	8	25
FL314	68	26	10	28
FL315	64	26	10	30
FL316	74	29	10	32
FL317	75	31	10	32
FL318	74	32	10	36
FL319	80	32	10	40
FL320	86	34	13	40
FL322	86	36	13	42
FL324	94	41	13	48

Appendix Table 6 Dimensional Tolerances of Shafts

Classification of shaft (mm)		Tolerance range class of shaft															
Over	Incl.	d 6	e 6	f 6	g 5	g 6	h 5	h 6	h 7	h 8	h 9	h 10	js 5	js 6	js 7	j 5	j 6
3	6	-30 -38	-20 -28	-10 -18	-4 -9	-4 -12	0 -5	0 -8	0 -12	0 -18	0 -30	0 -48	± 2.5	± 4	± 6	+ 3 - 2	+ 6 - 2
6	10	-40 -49	-25 -34	-13 -22	-5 -11	-5 -14	0 -6	0 -9	0 -15	0 -22	0 -36	0 -58	± 3	± 4.5	± 7.5	+ 4 - 2	+ 7 - 2
10	18	-50 -61	-32 -43	-16 -27	-6 -14	-6 -17	0 -8	0 -11	0 -18	0 -27	0 -43	0 -70	± 4	± 5.5	± 9	+ 5 - 3	+ 8 - 3
18	30	-65 -78	-40 -53	-20 -33	-7 -16	-7 -20	0 -9	0 -13	0 -21	0 -33	0 -52	0 -84	± 4.5	± 6.5	±10.5	+ 5 - 4	+ 9 - 4
30	50	-80 -96	-50 -66	-25 -41	-9 -20	-9 -25	0 -11	0 -16	0 -25	0 -39	0 -62	0 -100	± 5.5	± 8	±12.5	+ 6 - 5	+11 - 5
50	80	-100 -119	-60 -79	-30 -49	-10 -23	-10 -29	0 -13	0 -19	0 -30	0 -46	0 -74	0 -120	± 6.5	± 9.5	±15	+ 6 - 7	+12 - 7
80	120	-120 -142	-72 -94	-36 -58	-12 -27	-12 -34	0 -15	0 -22	0 -35	0 -54	0 -87	0 -140	± 7.5	±11	±17.5	+ 6 - 9	+13 - 9
120	180	-145 -170	-85 -110	-43 -68	-14 -32	-14 -39	0 -18	0 -25	0 -40	0 -63	0 -100	0 -160	± 9	±12.5	±20	+ 7 -11	+14 -11
180	250	-170 -199	-100 -129	-50 -79	-15 -35	-15 -44	0 -20	0 -29	0 -46	0 -72	0 -115	0 -185	±10	±14.5	±23	+ 7 -13	+16 -13
250	315	-190 -222	-110 -142	-56 -88	-17 -40	-17 -49	0 -23	0 -32	0 -52	0 -81	0 -130	0 -210	±11.5	±16	±26	+ 7 -16	±16
315	400	-210 -246	-125 -161	-62 -98	-18 -43	-18 -54	0 -25	0 -36	0 -57	0 -89	0 -140	0 -230	±12.5	±18	±28.5	+ 7 -18	±18
400	500	-230 -270	-135 -175	-68 -108	-20 -47	-20 -60	0 -27	0 -40	0 -63	0 -97	0 -155	0 -250	±13.5	±20	±31.5	+ 7 -20	±20
500	630	-260 -304	-145 -189	-76 -120	-22 -54	-22 -66	0 -32	0 -44	0 -70	0 -110	0 -175	0 -280	±16	±22	±35	-	-
630	800	-290 -340	-160 -210	-80 -130	-24 -60	-24 -74	0 -36	0 -50	0 -80	0 -125	0 -200	0 -320	±18	±25	±40	-	-
800	1,000	-320 -376	-170 -226	-86 -142	-26 -66	-26 -82	0 -40	0 -56	0 -90	0 -140	0 -230	0 -360	±20	±28	±45	-	-

* Δ_{dmp} : Variation of tolerance of average bore diameter in plane

												Unit: μm (Reference)		Δ_{dmp}^* of bearing (class 0)
												Classification of shaft (mm)		
k 5	k 6	k 7	m 5	m 6	m 7	n 5	n 6	p 6	r 6	r 7	Over	Incl.		
+ 6 + 1	+ 9 + 1	+13 + 1	+ 9 + 4	+12 + 4	+ 16 + 4	+13 + 8	+ 16 + 8	+ 20 + 12	+ 23 + 15	+ 27 + 15	3	6	0 - 8	
+ 7 + 1	+10 + 1	+16 + 1	+12 + 6	+15 + 6	+ 21 + 6	+16 +10	+ 19 + 10	+ 24 + 15	+ 28 + 19	+ 34 + 19	6	10	0 - 8	
+ 9 + 1	+12 + 1	+19 + 1	+15 + 7	+18 + 7	+ 25 + 7	+20 +12	+ 23 + 12	+ 29 + 18	+ 34 + 23	+ 41 + 23	10	18	0 - 8	
+11 + 2	+15 + 2	+23 + 2	+17 + 8	+21 + 8	+ 29 + 8	+24 +15	+ 28 + 15	+ 35 + 22	+ 41 + 28	+ 49 + 28	18	30	0 - 10	
+13 + 2	+18 + 2	+27 + 2	+20 + 9	+25 + 9	+ 34 + 9	+28 +17	+ 33 + 17	+ 42 + 26	+ 50 + 34	+ 59 + 34	30	50	0 - 12	
+15 + 2	+21 + 2	+32 + 2	+24 +11	+30 +11	+ 41 + 11	+33 +20	+ 39 + 20	+ 51 + 32	+ 60 + 41	+ 71 + 41	50	65	0 - 15	
									+ 62 + 43	+ 73 + 43	65	80		
+18 + 3	+25 + 3	+38 + 3	+28 +13	+35 +13	+ 48 + 13	+38 +23	+ 45 + 23	+ 59 + 37	+ 73 + 51	+ 86 + 51	80	100	0 - 20	
									+ 76 + 54	+ 89 + 54	100	120		
+21 + 3	+28 + 3	+43 + 3	+33 +15	+40 +15	+ 55 + 15	+45 +27	+ 52 + 27	+ 68 + 43	+ 88 + 63	+103 + 63	120	140	0 - 25	
									+ 90 + 65	+105 + 65	140	160		
									+ 93 + 68	+108 + 68	160	180		
+24 + 4	+33 + 4	+50 + 4	+37 +17	+46 +17	+ 63 + 17	+51 +31	+ 60 + 31	+ 79 + 50	+106 + 77	+123 + 77	180	200	0 - 30	
									+109 + 80	+126 + 80	200	225		
									+113 + 84	+130 + 84	225	250		
+27 + 4	+36 + 4	+56 + 4	+43 +20	+52 +20	+ 72 + 20	+57 +34	+ 66 + 34	+ 88 + 56	+126 + 94	+146 + 94	250	280	0 - 35	
									+130 + 98	+150 + 98	280	315		
+29 + 4	+40 + 4	+61 + 4	+46 +21	+57 +21	+ 78 + 21	+62 +37	+ 73 + 37	+ 98 + 62	+144 +108	+165 +108	315	355	0 - 40	
									+150 +114	+171 +114	355	400		
+32 + 5	+45 + 5	+68 + 5	+50 +23	+63 +23	+ 86 + 23	+67 +40	+ 80 + 40	+108 + 68	+166 +126	+189 +126	400	450	0 - 45	
									+172 +132	+195 +132	450	500		
+32 0	+44 0	+70 0	+58 +26	+70 +26	+ 96 + 26	+76 +44	+ 88 + 44	+122 + 78	+194 +150	+220 +150	500	560	0 - 50	
									+199 +155	+225 +155	560	630		
+36 0	+50 0	+80 0	+66 +30	+80 +30	+110 + 30	+86 +50	+100 + 50	+138 + 88	+225 +175	+255 +175	630	710	0 - 75	
									+235 +185	+265 +185	710	800		
+40 0	+56 0	+90 0	+74 +34	+90 +34	+124 + 34	+96 +56	+112 + 56	+156 +100	+266 +210	+300 +210	800	900	0 -100	
									+276 +220	+310 +220	900	1,000		

Appendix Table 7 Dimensional Tolerances of Housing Bores

Classification of shaft (mm)		Tolerance range class of bore														
Over	Incl.	E 6	F 6	F 7	G 6	G 7	H 6	H 7	H 8	H 9	H 10	JS 5	JS 6	JS 7	J 6	J 7
10	18	+ 43 + 32	+ 27 + 16	+ 34 + 16	+17 + 6	+ 24 + 6	+11 0	+ 18 0	+ 27 0	+ 43 0	+ 70 0	± 4	± 5.5	± 9	+ 6 - 5	+10 - 8
18	30	+ 53 + 40	+ 33 + 20	+ 41 + 20	+20 + 7	+ 28 + 7	+13 0	+ 21 0	+ 33 0	+ 52 0	+ 84 0	± 4.5	± 6.5	±10.5	+ 8 - 5	+12 - 9
30	50	+ 66 + 50	+ 41 + 25	+ 50 + 25	+25 + 9	+ 34 + 9	+16 0	+ 25 0	+ 39 0	+ 62 0	+100 0	± 5.5	± 8	±12.5	+10 - 6	+14 -11
50	80	+ 79 + 60	+ 49 + 30	+ 60 + 30	+29 +10	+ 40 + 10	+19 0	+ 30 0	+ 46 0	+ 74 0	+120 0	± 6.5	± 9.5	±15	+13 - 6	+18 -12
80	120	+ 94 + 72	+ 58 + 36	+ 71 + 36	+34 +12	+ 47 + 12	+22 0	+ 35 0	+ 54 0	+ 87 0	+140 0	± 7.5	±11	±17.5	+16 - 6	+22 -13
120	180	+110 + 85	+ 68 + 43	+ 83 + 43	+39 +14	+ 54 + 14	+25 0	+ 40 0	+ 63 0	+100 0	+160 0	± 9	±12.5	±20	+18 - 7	+26 -14
180	250	+129 +100	+ 79 + 50	+ 96 + 50	+44 +15	+ 61 + 15	+29 0	+ 46 0	+ 72 0	+115 0	+185 0	±10	±14.5	±23	+22 - 7	+30 -16
250	315	+142 +110	+ 88 + 56	+108 + 56	+49 +17	+ 69 + 17	+32 0	+ 52 0	+ 81 0	+130 0	+210 0	±11.5	±16	±26	+25 - 7	+36 -16
315	400	+161 +125	+ 98 + 62	+119 + 62	+54 +18	+ 75 + 18	+36 0	+ 57 0	+ 89 0	+140 0	+230 0	±12.5	±18	±28.5	+29 - 7	+39 -18
400	500	+175 +135	+108 + 68	+131 + 68	+60 +20	+ 83 + 20	+40 0	+ 63 0	+ 97 0	+155 0	+250 0	±13.5	±20	±31.5	+33 - 7	+43 -20
500	630	+189 +145	+120 + 76	+146 + 76	+66 +22	+ 92 + 22	+44 0	+ 70 0	+110 0	+175 0	+280 0	±16	±22	±35	-	-
630	800	+210 +160	+130 + 80	+160 + 80	+74 +24	+104 + 24	+50 0	+ 80 0	+125 0	+200 0	+320 0	±18	±25	±40	-	-
800	1,000	+226 +170	+142 + 86	+176 + 86	+82 +26	+116 + 26	+56 0	+ 90 0	+140 0	+230 0	+360 0	±20	±28	±45	-	-
1,000	1,250	+261 +195	+164 + 98	+203 + 98	+94 +28	+133 + 28	+66 0	+105 0	+165 0	+260 0	+420 0	±23.5	±33	±52.5	-	-

* $\Delta_{D_{mp}}$: Variation of tolerance of average outside diameter in plate

													Unit: μm (Reference)		Δ_{Dmp}^* of bearing (class 0)
													Classification of basic size (mm)		
K 5	K 6	K 7	M 5	M 6	M 7	N 5	N 6	N 7	P 6	P 7	R 7	Over	Incl.		
+ 2 - 6	+ 2 - 9	+ 6 - 12	- 4 - 12	- 4 - 15	0 - 18	- 9 - 17	- 9 - 20	- 5 - 23	- 15 - 26	- 11 - 29	- 16 - 34	10	18	0 - 8	
+ 1 - 8	+ 2 - 11	+ 6 - 15	- 5 - 14	- 4 - 17	0 - 21	- 12 - 21	- 11 - 24	- 7 - 28	- 18 - 31	- 14 - 35	- 20 - 41	18	30	0 - 9	
+ 2 - 9	+ 3 - 13	+ 7 - 18	- 5 - 16	- 4 - 20	0 - 25	- 13 - 24	- 12 - 28	- 8 - 33	- 21 - 37	- 17 - 42	- 25 - 50	30	50	0 - 11	
+ 3 - 10	+ 4 - 15	+ 9 - 21	- 6 - 19	- 5 - 24	0 - 30	- 15 - 28	- 14 - 33	- 9 - 39	- 26 - 45	- 21 - 51	- 30 - 60	50	65	0	
												- 32 - 62	65	80	- 13
+ 2 - 13	+ 4 - 18	+ 10 - 25	- 8 - 23	- 6 - 28	0 - 35	- 18 - 33	- 16 - 38	- 10 - 45	- 30 - 52	- 24 - 59	- 38 - 73	80	100	0	
												- 41 - 76	100	120	- 15
+ 3 - 15	+ 4 - 21	+ 12 - 28	- 9 - 27	- 8 - 33	0 - 40	- 21 - 39	- 20 - 45	- 12 - 52	- 36 - 61	- 28 - 68	- 48 - 88	120	140	(150 max.) 0	
												- 50 - 90	140	160	- 18
												- 53 - 93	160	180	(Over 150) 0 - 25
+ 2 - 18	+ 5 - 24	+ 13 - 33	- 11 - 31	- 8 - 37	0 - 46	- 25 - 45	- 22 - 51	- 14 - 60	- 41 - 70	- 33 - 79	- 60 - 106	180	200	0	
												- 63 - 109	200	225	- 30
												- 67 - 113	225	250	
+ 3 - 20	+ 5 - 27	+ 16 - 36	- 13 - 36	- 9 - 41	0 - 52	- 27 - 50	- 25 - 57	- 14 - 66	- 47 - 79	- 36 - 88	- 74 - 126	250	280	0	
												- 78 - 130	280	315	- 35
+ 3 - 22	+ 7 - 29	+ 17 - 40	- 14 - 39	- 10 - 46	0 - 57	- 30 - 55	- 26 - 62	- 16 - 73	- 51 - 87	- 41 - 98	- 87 - 144	315	355	0	
												- 93 - 150	355	400	- 40
+ 2 - 25	+ 8 - 32	+ 18 - 45	- 16 - 43	- 10 - 50	0 - 63	- 33 - 60	- 27 - 67	- 17 - 80	- 55 - 95	- 45 - 108	- 103 - 166	400	450	0	
												- 109 - 172	450	500	- 45
0 - 32	0 - 44	0 - 70	- 26 - 58	- 26 - 70	- 26 - 96	- 44 - 76	- 44 - 88	- 44 - 114	- 78 - 122	- 78 - 148	- 150 - 220	500	560	0	
												- 155 - 225	560	630	- 50
0 - 36	0 - 50	0 - 80	- 30 - 66	- 30 - 80	- 30 - 110	- 50 - 86	- 50 - 100	- 50 - 130	- 88 - 138	- 88 - 168	- 175 - 255	630	710	0	
												- 185 - 265	710	800	- 75
0 - 40	0 - 56	0 - 90	- 34 - 74	- 34 - 90	- 34 - 124	- 56 - 96	- 56 - 112	- 56 - 146	- 100 - 156	- 100 - 190	- 210 - 300	800	900	0	
												- 220 - 310	900	1,000	- 100
0 - 47	0 - 66	0 - 105	- 40 - 87	- 40 - 106	- 40 - 145	- 66 - 113	- 66 - 132	- 66 - 171	- 120 - 186	- 120 - 225	- 250 - 355	1,000	1,120	0	
												- 260 - 365	1,120	1,250	- 125

Appendix Table 8 Basic Tolerance Values

Classification of basic size (mm)		Tolerance class (IT)																	
		1	2	3	4	5	6	7	8	9	10	11	12	13	14 ¹⁾	15 ¹⁾	16 ¹⁾	17 ¹⁾	18 ¹⁾
Over	Incl.	Basic tolerance value (μm)											Basic tolerance value (mm)						
–	3	0.8	1.2	2	3	4	6	10	14	25	40	60	0.10	0.14	0.26	0.40	0.60	1.00	1.40
3	6	1	1.5	2.5	4	5	8	12	18	30	48	75	0.12	0.18	0.30	0.48	0.75	1.20	1.80
6	10	1	1.5	2.5	4	6	9	15	22	36	58	90	0.15	0.22	0.36	0.58	0.90	1.50	2.20
10	18	1.2	2	3	5	8	11	18	27	43	70	110	0.18	0.27	0.43	0.70	1.10	1.80	2.70
18	30	1.5	2.5	4	6	9	13	21	33	52	84	130	0.21	0.33	0.52	0.84	1.30	2.10	3.30
30	50	1.5	2.5	4	7	11	16	25	39	62	100	160	0.25	0.39	0.62	1.00	1.60	2.50	3.90
50	80	2	3	5	8	13	19	30	46	74	120	190	0.30	0.46	0.74	1.20	1.90	3.00	4.60
80	120	2.5	4	6	10	15	22	35	54	87	140	220	0.35	0.54	0.87	1.40	2.20	3.50	5.40
120	180	3.5	5	8	12	18	25	40	63	100	160	250	0.40	0.63	1.00	1.60	2.50	4.00	6.30
180	250	4.5	7	10	14	20	29	46	72	115	185	290	0.46	0.72	1.15	1.85	2.90	4.60	7.20
250	315	6	8	12	16	23	32	52	81	130	210	320	0.52	0.81	1.30	2.10	3.20	5.20	8.10
315	400	7	9	13	18	25	36	57	89	140	230	360	0.57	0.89	1.40	2.30	3.60	5.70	8.90
400	500	8	10	15	20	27	40	63	97	155	250	400	0.63	0.97	1.55	2.50	4.00	6.30	9.70
500	630	–	–	–	–	–	44	70	110	175	280	440	0.70	1.10	1.75	2.80	4.40	7.00	11.00
630	800	–	–	–	–	–	50	80	125	200	320	500	0.80	1.25	2.00	3.20	5.00	8.00	12.50
800	1,000	–	–	–	–	–	56	90	140	230	360	560	0.90	1.40	2.30	3.60	5.60	9.00	14.00
1,000	1,250	–	–	–	–	–	66	105	165	260	420	660	1.05	1.65	2.60	4.20	6.60	10.50	16.50
1,250	1,600	–	–	–	–	–	78	125	195	310	500	780	1.25	1.95	3.10	5.00	7.80	12.50	19.50
1,600	2,000	–	–	–	–	–	92	150	230	370	600	920	1.50	2.30	3.70	6.00	9.20	15.00	23.00
2,000	2,500	–	–	–	–	–	110	175	280	440	700	1,100	1.75	2.80	4.40	7.00	11.00	17.50	28.00
2,500	3,150	–	–	–	–	–	135	210	330	540	860	1,350	2.10	3.30	5.40	8.60	13.50	21.00	33.00

Note ¹⁾ Tolerance classes from IT14 to IT18 can not be applied to basic size 1 mm or less.

Appendix Table 9 SI Unit Conversion Charts

Force

N	dyn	kgf
1	1×10^5	$1.019\ 72 \times 10^{-1}$
1×10^{-5}	1	$1.019\ 72 \times 10^{-6}$
9.806 65	$9.806\ 65 \times 10^5$	1

Moment of force (torque)

N · m	mN · m	$\mu\text{N} \cdot \text{m}$	kgf · m	kgf · cm	gf · cm
1	1×10^3	1×10^6	$1.019\ 72 \times 10^{-1}$	$1.019\ 72 \times 10$	$1.019\ 72 \times 10^4$
1×10^{-3}	1	1×10^3	$1.019\ 72 \times 10^{-4}$	$1.019\ 72 \times 10^{-2}$	$1.019\ 72 \times 10$
1×10^{-6}	1×10^{-3}	1	$1.019\ 72 \times 10^{-7}$	$1.019\ 72 \times 10^{-5}$	$1.019\ 72 \times 10^{-2}$
9.806 65	$9.806\ 65 \times 10^3$	$9.806\ 65 \times 10^6$	1	1×10^2	1×10^5
$9.806\ 65 \times 10^{-2}$	$9.806\ 65 \times 10$	$9.806\ 65 \times 10^4$	1×10^{-2}	1	1×10^3
$9.806\ 65 \times 10^{-5}$	$9.806\ 65 \times 10^{-2}$	$9.806\ 65 \times 10$	1×10^{-5}	1×10^{-3}	1

Stress

Pa or N/m ²	MPa or N/mm ²	kgf/mm ²	kgf/cm ²
1	1×10^{-6}	$1.019\ 72 \times 10^{-7}$	$1.019\ 72 \times 10^{-5}$
1×10^6	1	$1.019\ 72 \times 10^{-1}$	$1.019\ 72 \times 10$
$9.806\ 65 \times 10^6$	9.806 65	1	1×10^2
$9.806\ 65 \times 10^4$	$9.806\ 65 \times 10^{-2}$	1×10^{-2}	1

Remark 1 Pa = 1 N/m², 1 MPa = 1 N/mm²

Pressure

Pa	kPa	MPa	bar	kgf/cm ²	atm	mmH ₂ O	mmHg or Torr
1	1×10^{-3}	1×10^{-6}	1×10^{-5}	$1.019\ 72 \times 10^{-5}$	$9.869\ 23 \times 10^{-6}$	$1.019\ 72 \times 10^{-1}$	$7.500\ 62 \times 10^{-3}$
1×10^3	1	1×10^{-3}	1×10^{-2}	$1.019\ 72 \times 10^{-2}$	$9.869\ 23 \times 10^{-3}$	$1.019\ 72 \times 10^2$	7.500 62
1×10^6	1×10^3	1	1×10	$1.019\ 72 \times 10$	9.869 23	$1.019\ 72 \times 10^5$	$7.500\ 62 \times 10^3$
1×10^5	1×10^2	1×10^{-1}	1	1.019 72	$9.869\ 23 \times 10^{-1}$	$1.019\ 72 \times 10^4$	$7.500\ 62 \times 10^2$
$9.806\ 65 \times 10^4$	$9.806\ 65 \times 10$	$9.806\ 65 \times 10^{-2}$	$9.806\ 65 \times 10^{-1}$	1	$9.678\ 41 \times 10^{-1}$	1×10^4	$7.355\ 59 \times 10^2$
$1.013\ 25 \times 10^5$	$1.013\ 25 \times 10^2$	$1.013\ 25 \times 10^{-1}$	1.013 25	1.033 23	1	$1.033\ 23 \times 10^4$	$7.600\ 00 \times 10^2$
9.806 65	$9.806\ 65 \times 10^{-3}$	$9.806\ 65 \times 10^{-6}$	$9.806\ 65 \times 10^{-5}$	1×10^{-4}	$9.678\ 41 \times 10^{-5}$	1	$7.355\ 59 \times 10^{-2}$
$1.333\ 22 \times 10^2$	$1.333\ 22 \times 10^{-1}$	$1.333\ 22 \times 10^{-4}$	$1.333\ 22 \times 10^{-3}$	$1.359\ 51 \times 10^{-3}$	$1.315\ 79 \times 10^{-3}$	$1.359\ 51 \times 10$	1

Remark 1 Pa = 1 N/m²

Kinematic viscosity

m ² /s	cSt	St
1	1×10^6	1×10^4
1×10^{-6}	1	1×10^{-2}
1×10^{-4}	1×10^2	1

Remark 1 cSt = 1 mm²/s, 1 St = 1 cm²/s

Appendix Table 10 Inch-meter Conversion Chart

Inch	Inches											
	0	1	2	3	4	5	6	7	8	9	10	
	mm											
0	0	0	25.4000	50.8000	76.2000	101.6000	127.0000	152.4000	177.8000	203.2000	228.6000	254.0000
1/64	0.015625	0.3969	25.7969	51.1969	76.5969	101.9969	127.3969	152.7969	178.1969	203.5969	228.9969	254.3969
1/32	0.03125	0.7938	26.1938	51.5938	76.9938	102.3938	127.7938	153.1938	178.5938	203.9938	229.3938	254.7938
3/64	0.046875	1.1906	26.5906	51.9906	77.3906	102.7906	128.1906	153.5906	178.9906	204.3906	229.7906	255.1906
1/16	0.0625	1.5875	26.9875	52.3875	77.7875	103.1875	128.5875	153.9875	179.3875	204.7875	230.1875	255.5875
5/64	0.078125	1.9844	27.3844	52.7844	78.1844	103.5844	128.9844	154.3844	179.7844	205.1844	230.5844	255.9844
3/32	0.09375	2.3812	27.7812	53.1812	78.5812	103.9812	129.3812	154.7812	180.1812	205.5812	230.9812	256.3812
7/64	0.109375	2.7781	28.1781	53.5781	78.9781	104.3781	129.7781	155.1781	180.5781	205.9781	231.3781	256.7781
1/8	0.125	3.1750	28.5750	53.9750	79.3750	104.7750	130.1750	155.5750	180.9750	206.3750	231.7750	257.1750
9/64	0.140625	3.5719	28.9719	54.3719	79.7719	105.1719	130.5719	155.9719	181.3719	206.7719	232.1719	257.5719
5/32	0.15625	3.9688	29.3688	54.7688	80.1688	105.5688	130.9688	156.3688	181.7688	207.1688	232.5688	257.9688
11/64	0.171875	4.3656	29.7656	55.1656	80.5656	105.9656	131.3656	156.7656	182.1656	207.5656	232.9656	258.3656
3/16	0.1875	4.7625	30.1625	55.5625	80.9625	106.3625	131.7625	157.1625	182.5625	207.9625	233.3625	258.7625
13/64	0.203125	5.1594	30.5594	55.9594	81.3594	106.7594	132.1594	157.5594	182.9594	208.3594	233.7594	259.1594
7/32	0.21875	5.5562	30.9562	56.3562	81.7562	107.1562	132.5562	157.9562	183.3562	208.7562	234.1562	259.5562
15/64	0.234375	5.9531	31.3531	56.7531	82.1531	107.5531	132.9531	158.3531	183.7531	209.1531	234.5531	259.9531
1/4	0.25	6.3500	31.7500	57.1500	82.5500	107.9500	133.3500	158.7500	184.1500	209.5500	234.9500	260.3500
17/64	0.265625	6.7469	32.1469	57.5469	82.9469	108.3469	133.7469	159.1469	184.5469	209.9469	235.3469	260.7469
9/32	0.28125	7.1438	32.5438	57.9438	83.3438	108.7438	134.1438	159.5438	184.9438	210.3438	235.7438	261.1438
19/64	0.296875	7.5406	32.9406	58.3406	83.7406	109.1406	134.5406	159.9406	185.3406	210.7406	236.1406	261.5406
5/16	0.3125	7.9375	33.3375	58.7375	84.1375	109.5375	134.9375	160.3375	185.7375	211.1375	236.5375	261.9375
21/64	0.328125	8.3344	33.7344	59.1344	84.5344	109.9344	135.3344	160.7344	186.1344	211.5344	236.9344	262.3344
11/32	0.34375	8.7312	34.1312	59.5312	84.9312	110.3312	135.7312	161.1312	186.5312	211.9312	237.3312	262.7312
23/64	0.359375	9.1281	34.5281	59.9281	85.3281	110.7281	136.1281	161.5281	186.9281	212.3281	237.7281	263.1281
3/8	0.375	9.5250	34.9250	60.3250	85.7250	111.1250	136.5250	161.9250	187.3250	212.7250	238.1250	263.5250
25/64	0.390625	9.9219	35.3219	60.7219	86.1219	111.5219	136.9219	162.3219	187.7219	213.1219	238.5219	263.9219
13/32	0.40625	10.3188	35.7188	61.1188	86.5188	111.9188	137.3188	162.7188	188.1188	213.5188	238.9188	264.3188
27/64	0.421875	10.7156	36.1156	61.5156	86.9156	112.3156	137.7156	163.1156	188.5156	213.9156	239.3156	264.7156
7/16	0.4375	11.1125	36.5125	61.9125	87.3125	112.7125	138.1125	163.5125	188.9125	214.3125	239.7125	265.1125
29/64	0.453125	11.5094	36.9094	62.3094	87.7094	113.1094	138.5094	163.9094	189.3094	214.7094	240.1094	265.5094
15/32	0.46875	11.9062	37.3062	62.7062	88.1062	113.5062	138.9062	164.3062	189.7062	215.1062	240.5062	265.9062
31/64	0.484375	12.3031	37.7031	63.1031	88.5031	113.9031	139.3031	164.7031	190.1031	215.5031	240.9031	266.3031
1/2	0.5	12.7000	38.1000	63.5000	88.9000	114.3000	139.7000	165.1000	190.5000	215.9000	241.3000	266.7000
33/64	0.515625	13.0969	38.4969	63.8969	89.2969	114.6969	140.0969	165.4969	190.8969	216.2969	241.6969	267.0969
17/32	0.53125	13.4938	38.8938	64.2938	89.6938	115.0938	140.4938	165.8938	191.2938	216.6938	242.0938	267.4938
35/64	0.546875	13.8906	39.2906	64.6906	90.0906	115.4906	140.8906	166.2906	191.6906	217.0906	242.4906	267.8906
9/16	0.5625	14.2875	39.6875	65.0875	90.4875	115.8875	141.2875	166.6875	192.0875	217.4875	242.8875	268.2875
37/64	0.578125	14.6844	40.0844	65.4844	90.8844	116.2844	141.6844	167.0844	192.4844	217.8844	243.2844	268.6844
19/32	0.59375	15.0812	40.4812	65.8812	91.2812	116.6812	142.0812	167.4812	192.8812	218.2812	243.6812	269.0812
39/64	0.609375	15.4781	40.8781	66.2781	91.6781	117.0781	142.4781	167.8781	193.2781	218.6781	244.0781	269.4781
5/8	0.625	15.8750	41.2750	66.6750	92.0750	117.4750	142.8750	168.2750	193.6750	219.0750	244.4750	269.8750
41/64	0.640625	16.2719	41.6719	67.0719	92.4719	117.8719	143.2719	168.6719	194.0719	219.4719	244.8719	270.2719
21/32	0.65625	16.6688	42.0688	67.4688	92.8688	118.2688	143.6688	169.0688	194.4688	219.8688	245.2688	270.6688
43/64	0.671875	17.0656	42.4656	67.8656	93.2656	118.6656	144.0656	169.4656	194.8656	220.2656	245.6656	271.0656
11/16	0.6875	17.4625	42.8625	68.2625	93.6625	119.0625	144.4625	169.8625	195.2625	220.6625	246.0625	271.4625
45/64	0.703125	17.8594	43.2594	68.6594	94.0594	119.4594	144.8594	170.2594	195.6594	221.0594	246.4594	271.8594
23/32	0.71875	18.2562	43.6562	69.0562	94.4562	119.8562	145.2562	170.6562	196.0562	221.4562	246.8562	272.2562
47/64	0.734375	18.6531	44.0531	69.4531	94.8531	120.2531	145.6531	171.0531	196.4531	221.8531	247.2531	272.6531
3/4	0.75	19.0500	44.4500	69.8500	95.2500	120.6500	146.0500	171.4500	196.8500	222.2500	247.6500	273.0500
49/64	0.765625	19.4469	44.8469	70.2469	95.6469	121.0469	146.4469	171.8469	197.2469	222.6469	248.0469	273.4469
25/32	0.78125	19.8438	45.2438	70.6438	96.0438	121.4438	146.8438	172.2438	197.6438	223.0438	248.4438	273.8438
51/64	0.796875	20.2406	45.6406	71.0406	96.4406	121.8406	147.2406	172.6406	198.0406	223.4406	248.8406	274.2406
13/16	0.8125	20.6375	46.0375	71.4375	96.8375	122.2375	147.6375	173.0375	198.4375	223.8375	249.2375	274.6375
53/64	0.828125	21.0344	46.4344	71.8344	97.2344	122.6344	148.0344	173.4344	198.8344	224.2344	249.6344	275.0344
27/32	0.84375	21.4312	46.8312	72.2312	97.6312	123.0312	148.4312	173.8312	199.2312	224.6312	250.0312	275.4312
55/64	0.859375	21.8281	47.2281	72.6281	98.0281	123.4281	148.8281	174.2281	199.6281	225.0281	250.4281	275.8281
7/8	0.875	22.2250	47.6250	73.0250	98.4250	123.8250	149.2250	174.6250	200.0250	225.4250	250.8250	276.2250
57/64	0.890625	22.6219	48.0219	73.4219	98.8219	124.2219	149.6219	175.0219	200.4219	225.8219	251.2219	276.6219
29/32	0.90625	23.0188	48.4188	73.8188	99.2188	124.6188	150.0188	175.4188	200.8188	226.2188	251.6188	277.0188
59/64	0.921875	23.4156	48.8156	74.2156	99.6156	125.0156	150.4156	175.8156	201.2156	226.6156	252.0156	277.4156
15/16	0.9375	23.8125	49.2125	74.6125	100.0125	125.4125	150.8125	176.2125	201.6125	227.0125	252.4125	277.8125
61/64	0.953125	24.2094	49.6094	75.0094	100.4094	125.8094	151.2094	176.6094	202.0094	227.4094	252.8094	278.2094
31/32	0.96875	24.6062	50.0062	75.4062	100.8062	126.2062	151.6062	177.0062	202.4062	227.8062	253.2062	278.6062
63/64	0.984375	25.0031	50.4031	75.8031	101.2031	126.6031	152.0031	177.4031	202.8031	228.2031	253.6031	27

Appendix Table 11 Hardness Conversion Chart

Rockwell C scale 1,471.0 N (150 kgf)	Vickers	Brinell		Rockwell		Shore
		Standard steel ball	Tungsten carbide steel ball	A scale 588.4 N (60 kgf)	B scale 980.7 N (100 kgf)	
68	940			85.6		97
67	900			85.0		95
66	865			84.5		92
65	832		739	83.9		91
64	800		722	83.4		88
63	772		705	82.8		87
62	746		688	82.3		85
61	720		670	81.8		83
60	697		654	81.2		81
59	674		634	80.7		80
58	653		615	80.1		78
57	633		595	79.6		76
56	613		577	79.0		75
55	595	–	560	78.5		74
54	577	–	543	78.0		72
53	560	–	525	77.4		71
52	544	500	512	76.8		69
51	528	487	496	76.3		68
50	513	475	481	75.9		67
49	498	464	469	75.2		66
48	484	451	455	74.7		64
47	471	442	443	74.1		63
46	458	432	432	73.6		62
45	446		421	73.1		60
44	434		409	72.5		58
43	423		400	72.0		57
42	412		390	71.5		56
41	402		381	70.9		55
40	392		371	70.4	–	54
39	382		362	69.9	–	52
38	372		353	69.4	–	51
37	363		344	68.9	–	50
36	354		336	68.4	(109.0)	49
35	345		327	67.9	(108.5)	48
34	336		319	67.4	(108.0)	47
33	327		311	66.8	(107.5)	46
32	318		301	66.3	(107.0)	44
31	310		294	65.8	(106.0)	43
30	302		286	65.3	(105.5)	42
29	294		279	64.7	(104.5)	41
28	286		271	64.3	(104.0)	41
27	279		264	63.8	(103.0)	40
26	272		258	63.3	(102.5)	38
25	266		253	62.8	(101.5)	38
24	260		247	62.4	(101.0)	37
23	254		243	62.0	100.0	36
22	248		237	61.5	99.0	35
21	243		231	61.0	98.5	35
20	238		226	60.5	97.8	34
(18)	230		219	–	96.7	33
(16)	222		212	–	95.5	32
(14)	213		203	–	93.9	31
(12)	204		194	–	92.3	29
(10)	196		187		90.7	28
(8)	188		179		89.5	27
(6)	180		171		87.1	26
(4)	173		165		85.5	25
(2)	166		158		83.5	24
(0)	160		152		81.7	24

Appendix Table 12 Viscosity Conversion Chart

Kinematic viscosity mm ² /s	Saybolt SUS (second)		Redwood R (second)		Engler E (degree)
	100 °F	210 °F	50 °C	100 °C	
	2	32.6	32.8	30.8	
3	36.0	36.3	33.3	33.7	1.22
4	39.1	39.4	35.9	36.5	1.31
5	42.3	42.6	38.5	39.1	1.40
6	45.5	45.8	41.1	41.7	1.48
7	48.7	49.0	43.7	44.3	1.56
8	52.0	52.4	46.3	47.0	1.65
9	55.4	55.8	49.1	50.0	1.75
10	58.8	59.2	52.1	52.9	1.84
11	62.3	62.7	55.1	56.0	1.93
12	65.9	66.4	58.2	59.1	2.02
13	69.6	70.1	61.4	62.3	2.12
14	73.4	73.9	64.7	65.6	2.22
15	77.2	77.7	68.0	69.1	2.32
16	81.1	81.7	71.5	72.6	2.43
17	85.1	85.7	75.0	76.1	2.54
18	89.2	89.8	78.6	79.7	2.64
19	93.3	94.0	82.1	83.6	2.76
20	97.5	98.2	85.8	87.4	2.87
21	102	102	89.5	91.3	2.98
22	106	107	93.3	95.1	3.10
23	110	111	97.1	98.9	3.22
24	115	115	101	103	3.34
25	119	120	105	107	3.46
26	123	124	109	111	3.58
27	128	129	112	115	3.70
28	132	133	116	119	3.82
29	137	138	120	123	3.95
30	141	142	124	127	4.07
31	145	146	128	131	4.20
32	150	150	132	135	4.32
33	154	155	136	139	4.45
34	159	160	140	143	4.57
35	163	164	144	147	4.70
36	168	170	148	151	4.83
37	172	173	153	155	4.96
38	177	178	156	159	5.08
39	181	183	160	164	5.21
40	186	187	164	168	5.34
41	190	192	168	172	5.47
42	195	196	172	176	5.59
43	199	201	176	180	5.72
44	204	205	180	185	5.85
45	208	210	184	189	5.98
46	213	215	188	193	6.11
47	218	219	193	197	6.24
48	222	224	197	202	6.37
49	227	228	201	206	6.50
50	231	233	205	210	6.63
55	254	256	225	231	7.24
60	277	279	245	252	7.90
65	300	302	266	273	8.55
70	323	326	286	294	9.21
75	346	349	306	315	9.89
80	371	373	326	336	10.5
85	394	397	347	357	11.2
90	417	420	367	378	11.8
95	440	443	387	399	12.5
100	464	467	408	420	13.2
120	556	560	490	504	15.8
140	649	653	571	588	18.4
160	742	747	653	672	21.1
180	834	840	734	757	23.7
200	927	933	816	841	26.3
250	1,159	1,167	1,020	1,051	32.9
300	1,391	1,400	1,224	1,241	39.5

Remark 1 mm²/s = 1 cSt (centistokes)

Appendix Table 13 Mechanical Properties of Metal Materials (reference)

(1) Modulus of longitudinal elasticity, elastic limit, and ultimate strength

Material	Main components and others	Specific gravity	Modulus of longitudinal elasticity (GPa)	Elastic limit σ_e (MPa)	Ultimate strength (MPa)		
					Tensile K_t	Compression K_c	Shear K_s
Gray cast iron (FC150)		7.1–7.3	69	29	118	590	108
(FC200)		7.1–7.3	98	88	137– 216	740	206
(FC250)		7.1–7.3	103	88	176– 314	880	206
White heart malleable cast iron	Residual carbon: 1.6% or less	7.1–7.3	158	196	314– 392	820	382
Black heart malleable cast iron		7.2–7.6	158	196	274– 392	820	382
Carbon steel	General	7.7–7.8	196–216	176–245	314– 830	–	–
Extra mild steel	C 0.05–0.15%	7.8	196	118	Over 372	Virtually identical to tensile strength, provided buckling can be ignored	0.8 K_t
Mild steel	C 0.15–0.25%	7.8	204	157	372– 392		0.75 K_t
Middle hard steel	C 0.25–0.40%	7.8	206	245–294	490– 590		0.75 K_t
Hard steel	C 0.40–0.50%	7.8	216	343	590– 690		0.7 K_t
Maximum hard steel	C 0.50–0.65%	7.8	216	372	690– 830		0.65 K_t
Mild steel	C 0.18% hot rolling	7.8	206	176	421		314
Hard steel	Oil hardening, tempering at 700 °C	7.8	206	343	590		461
Tool steel	C 0.60–1.50% hardening	7.8	216	441	660	820	
Cast steel	General	7.8–7.9	206–211	176–245	343– 600	343–600	284–382
Cast steel (mild)	C 0.15–0.22%	7.8–7.9	206	196	363– 431	363–431	284
Cast steel (middle hard)	C 0.22–0.30%	7.8–7.9	211	225	392– 490	392–490	333
Cast steel (hard)	C 0.30–0.40%	7.9	211	245	490– 590	490–590	382
Nickel steel	C 0.25–0.35% Ni 2–5%	7.85	206–216	333	640– 830	640	401
Chrome steel	C 0.13–0.48% Cr 0.9–1.2%	7.85	206–216	–	780– 980	–	–
Nickel chrome steel	C, Ni, Cr included	7.85	206–216	–	740– 980	–	382–500
Chromium molybdenum steel	C, Cr, Mo included	7.85	206–216	–	830– 980	–	–
Manganese steel	C 0.2–0.46% Mn 1–1.4%	7.85	206–216	–	440–1,080	–	–
Spring steel		7.86	216	735	1,080–1,670	1,670	–
Stainless steel	C, Cr, Ni included	7.75	206–216	–	620	–	410
Brass casting	Cu 60% Zn 40%	8.5	69	–	176– 216	108	147
Brass (forged plate)	Cu 60% Zn 40%	8.4	78– 98	–	274– 392	314	206
Brass (forged rod)	Cu 60% Zn 40%	8.4	82	–	520	314	314
Phosphor bronze casting	Cu 90% Sn 10% P 0.1%	8.8	93–103	–	196– 294	137	176
Phosphor bronze (forging)	Cu 90% Sn 10% P 0.1%	8.8	132	–	294– 980	206	382
Tin		7.28	39– 54	–	27	–	–
Lead		11.34	15– 17	–	20	–	–
Zinc		7.1	78–127	–	78– 176	–	–

(2) Allowable stress

Unit: MPa

Material	Tensile K_t			Compression K_c		Bending K_b			Shear K_s			Torsion K_d		
	<i>a</i>	<i>b</i>	<i>c</i>	<i>a</i>	<i>b</i>	<i>a</i>	<i>b</i>	<i>c</i>	<i>a</i>	<i>b</i>	<i>c</i>	<i>a</i>	<i>b</i>	<i>c</i>
Cast iron (cast)	29– 34	20– 23	10–12	88– 98	59– 65	45– 59	30– 39	15–20	29– 34	20–23	10–12	26– 34	18–23	88–118
Cast iron (machined)	29– 34	20– 23	10–12	88– 98	59– 65	55– 71	–	–	29– 34	20–23	10–12	26– 34	18–23	88–118
Malleable cast iron	44– 69	29– 46	15–23	59– 88	39– 59	44– 98	29– 46	15–23	–	–	–	29– 39	20–26	10– 13
Cast steel	59–118	39– 78	20–39	88–147	59– 98	74–118	49– 78	25–39	47– 94	31–63	16–31	47– 94	31–63	16– 31
Mild steel	98–157	66–105	32–52	98–157	66–105	88–147	59– 98	35–49	78–127	52–85	26–42	78–137	52–91	26– 46
Middle hard steel	118–176	78–118	39–59	118–176	78–118	118–176	78–118	39–59	94–137	63–94	31–47	88–137	59–94	29– 47
Nickel steel	118–176	78–118	39–59	118–176	78–118	118–176	78–118	39–59	94–137	63–94	31–47	88–137	59–92	29– 47
Carbon steel casting	88–118	59– 78	29–39	88–118	59– 78	88–118	59– 78	29–39	71– 93	47–63	24–31	35– 47	24–31	12– 16
Brass (rolled)	10– 59	26– 35	13–20	39– 59	26– 39	39– 59	26– 39	13–20	34– 47	21–31	11–16	31– 47	21–31	11– 16
Bronze	29– 39	20– 26	10–13	29– 39	20– 26	29– 39	20– 26	10–13	–	–	–	–	–	–
Phosphor bronze	59– 88	39– 59	20–29	59– 88	39– 59	59– 88	39– 59	20–29	44– 69	29–46	15–23	44– 69	29–46	15– 23
Aluminum casting	10– 12	7– 8	2– 4	–	–	15– 20	10– 13	5– 7	–	–	–	–	–	–

Remarks 1. *a* is applicable in the case of static load, *b* is applicable in the case of dynamic load, and *c* is applicable to in the case of repeated load.

2. Bending allowable stress K_b and torsion allowable stress K_d of cast iron are applicable when the cross section is round and safety factor is within a range from 5 to 6.

Appendix Table 14 (1) Hexagon Socket Head Cap Screws (abstract from JIS B 1176: 1988)

M 1.6 – 24

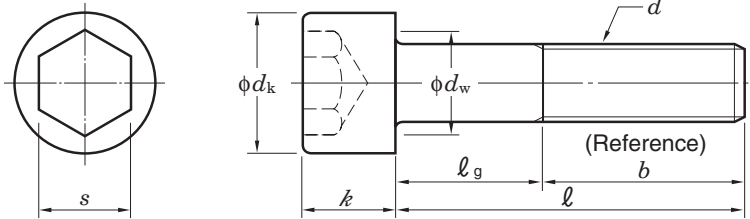

Allowance of bolt length (ℓ)

Unit: mm

Bolt length (ℓ)		Allowance of length
Over	Incl.	
-	3	± 0.2
3	6	± 0.24
6	10	± 0.29
10	16	± 0.35
16	30	± 0.42
30	50	± 0.5
50	80	± 0.6
80	120	± 0.7
120	180	± 0.8
180	240	± 0.95
240	300	± 1.05

(1) Parts class A M 1.6–24

Unit: mm

Nominal size of screw d	Coarse screw thread pitch	M 1.6	M 2	M 2.5	M 3	M 4	M 5	M 6	M 8	M 10	M 12	(M 14)	M 16	(M 18)	M 20	(M 22)	M 24
Head dia. d_k		3	3.8	4.5	5.5	7	8.5	10	13	16	18	21	24	27	30	33	36
Head height k		1.6	2	2.5	3	4	5	6	8	10	12	14	16	18	20	22	24
Bearing surface dia. d_w (min.)		2.72	3.4	4.18	5.07	6.53	8.03	9.38	12.33	15.33	17.23	20.17	23.17	25.87	28.87	31.81	34.81
Nominal size of hexagon socket s		1.5	1.5	2	2.5	3	4	5	6	8	10	12	14	14	17	17	19
Thread length b (reference)		15	16	17	18	20	22	24	28	32	36	40	44	48	52	56	60

Nominal length ℓ	M 1.6	Body length ℓ_g (max.)															
2.5		M 2															
3			M 2.5														
4				M 3													
5					M 4												
6						M 5											
8							M 6										
10								M 8									
12									M 10								
16			M 2							M 12							
20		4	M 2.5	M 3							(M 14)	M 16					
25			8	7	M 4	M 5							(M 18)	M 20			
30				12	10	8	M 6										
35					15	13	11	M 8								(M 22)	M 24
40					20	18	16	12	M 10								
45					23	21	17	13	M 12								
50					28	26	22	18	14								
55					31	27	23	19		(M 14)	M 16						
60					36	32	28	24	20	16	(M 18)						
65								37	33	29	25	21	17	(M 20)			
70								42	38	34	30	26	22	18	(M 22)		
80								52	48	44	40	36	32	28	24	(M 24)	
90									58	54	50	46	42	38	34	30	
100									68	64	60	56	52	48	44	40	
110										74	70	66	62	58	54	50	
120										84	80	76	72	68	64	60	
130											90	86	82	78	74	70	
140												100	96	92	88	84	80
150													106	102	98	94	90
160														116	112	108	104
180															132	128	124
200																148	144

- Remarks
- Priority is given to the nominal sizes of screws without parentheses.
 - Nominal lengths (ℓ) to be recommended for the nominal sizes of screw are within the range enclosed by bold lines in the column of "Body length ℓ_g ". In the column of "Body length ℓ_g ", thread of the screw with length shorter than that indicated under dotted lines should be continuous. For the continuous thread stud screw, the incomplete thread portion length under the neck of the screw should be approximately three times of the thread pitch.
 - The sides of the head of screw should be single or double knurled. The d_k values in the table are the maximum values without knurls.
 - Roundness or chamfers on the bearing surface should be provided between the diameter of the head (d_k) and the diameter of bearing surface (d_w), and the surface should be free from burrs.

Appendix Table 14 (2) Hexagon Socket Head Cap Screws (abstract from JIS B 1176: 1988)

M 27 – 52

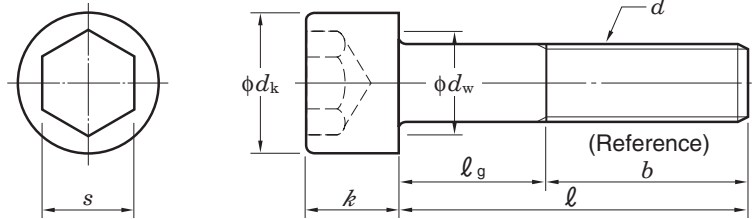

Allowance of bolt length (ℓ)

Unit: mm

Bolt length (ℓ)		Allowance of length
Over	Incl.	
-	3	± 0.2
3	6	± 0.24
6	10	± 0.29
10	16	± 0.35
16	30	± 0.42
30	50	± 0.5
50	80	± 0.6
80	120	± 0.7
120	180	± 0.8
180	240	± 0.95
240	300	± 1.05

(2) Parts class A M 27–52

Unit: mm

Nominal size of screw d	Coarse screw thread pitch	(M 27)	(M 30)	(M 33)	(M 36)	(M 39)	(M 42)	(M 45)	(M 48)	(M 52)
		3	3.5	4	4	4.5	4.5	5	5	
Head dia. d_k		40	45	50	54	58	63	68	72	78
Head height k		27	30	33	36	39	42	45	48	52
Bearing surface dia. d_w (min.)		38.61	43.61	48.61	52.54	56.34	61.34	66.34	70.34	76.34
Nominal size of hexagon socket s		19	22	24	27	27	32	32	36	36
Thread length b (reference)		66	72	78	84	90	96	102	108	116

Nominal length ℓ	(M 27)	(M 30)	Body length ℓ_g (max.)							
	45									
50			(M 33)	M 36						
55					(M 39)	M 42				
60							(M 45)	M 48		
65										
70										
80	(M 27)									(M 52)
90	24	M 30	(M 33)							
100	34	28	22							
110	44	38	32	M 36	(M 39)	M 42				
120	54	48	42	36	30	24	(M 45)			
130	64	58	52	46	40	34	28	M 48		
140	74	68	62	56	50	44	38	32	(M 52)	
150	84	78	72	66	60	54	48	42	34	
160	94	88	82	76	70	64	58	52	44	
180	114	108	102	96	90	84	78	72	64	
200	134	128	122	116	110	104	98	92	84	
220	154	148	142	136	130	124	118	112	104	
240	174	168	162	156	150	144	138	132	124	
260	194	188	182	176	170	164	158	152	144	
280	214	208	202	196	190	184	178	172	164	
300	234	228	222	216	210	204	198	192	184	

- Remarks
1. Priority is given to the nominal sizes of screws without parentheses.
 2. Nominal lengths (ℓ) to be recommended for the nominal sizes of screw are within the range enclosed by bold lines in the column of "Body length ℓ_g ". In the column of "Body length ℓ_g ", thread of the screw with length shorter than that indicated under dotted lines should be continuous. For the continuous thread stud screw, the incomplete thread portion length under the neck of the screw should be approximately three times of the thread pitch.
 3. The sides of the head of screw should be single or double knurled. The d_k values in the table are the maximum values without knurls.
 4. Roundness or chamfers on the bearing surface should be provided between the diameter of the head (d_k) and the diameter of bearing surface (d_w), and the surface should be free from burrs.

Appendix Table 15 (1) Hexagon Head Bolts (abstract from JIS B 1180: 1994)

Parts class A M 1.6 – 24

Allowance of bolt length (ℓ)

Unit: mm

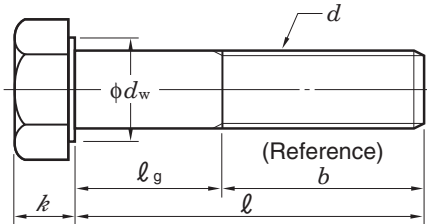
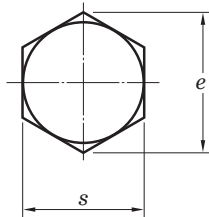

Bolt length (ℓ)		Allowance of length
Over	Incl.	
–	20	±0.35
20	30	±0.42
30	50	±0.5
50	80	±0.6
80	120	±0.7
120	150	±0.8

(1) Parts class A M 1.6–24

Unit: mm

Nominal size of screw d	Coarse screw thread pitch	M 1.6	M 2	M 2.5	M 3	(M 3.5)	M 4	M 5	M 6	M 8	M 10	M 12	(M 14)	M 16	(M 18)	M 20	(M 22)	M 24
		Fine thread	–	–	–	–	–	–	–	–	M 8 x 1	M 10 x 1	M 12 x 1.5	–	M 16 x 1.5	–	M 20 x 1.5	–
Bearing surface dia. d_w (min.)		2.27	3.07	4.07	4.57	5.07	5.88	6.88	8.88	11.63	14.63	16.63	19.64	22.49	25.34	28.19	31.71	33.61
Width across flats s (max.)		3.2	4	5	5.5	6	7	8	10	13	16	18	21	24	27	30	34	36
Width across corners e (min.)		3.41	4.32	5.45	6.01	6.58	7.66	8.79	11.05	14.38	17.77	20.03	23.36	26.75	30.14	33.53	37.72	39.98
Head height k (basic)		1.1	1.4	1.7	2	2.4	2.8	3.5	4	5.3	6.4	7.5	8.8	10	11.5	12.5	14	15
Thread length b (reference)	$\ell \leq 125$	9	10	11	12	13	14	16	18	22	26	30	34	38	42	46	50	54
	$125 < \ell \leq 150$	–	–	–	–	–	–	–	–	–	–	–	40	44	48	52	56	60

Nominal length ℓ	Body length ℓ_g (max.)																		
12	3	M 2 M 2.5																	
16	7	6	5	M 3 (M 3.5)															
20		10	9	8	7	M 4	M 5												
25			14	13	12	11	9	M 6											
30				18	17	16	14	12											
35					22	21	19	17	M 8										
40						26	24	22	18	M 10									
45							29	27	23	19	M 12								
50							34	32	28	24	20								
55								37	33	29	25	(M 14)							
60								42	38	34	30	26	M 16						
65									43	39	35	31	27	(M 18)					
70										48	44	40	36	32	28	M 20			
80										58	54	50	46	42	38	34	(M 22)	M 24	
90											64	60	56	52	48	44	40	36	
100												74	70	66	62	58	54	50	46
110													80	76	72	68	64	60	56
120														90	86	82	78	74	70
130															100	96	92	88	84
140																106	102	98	94
150																			90

As for the bolts with nominal length within this area, standards of continuous thread stud hexagon head bolt (parts class A) should be observed.

- Remarks 1. Priority is given to the nominal sizes of screws without parentheses.
- 2. Nominal lengths (ℓ) to be recommended for the nominal sizes of screw are within the range enclosed by bold lines.
- 3. Body length ℓ_g (maximum) should be found by the following formula : ℓ_g (maximum) = Nominal length (ℓ) – Thread length (b)

Appendix Table 15 (2) Hexagon Head Bolts (abstract from JIS B 1180: 1994)

Parts class B M 16 – 64

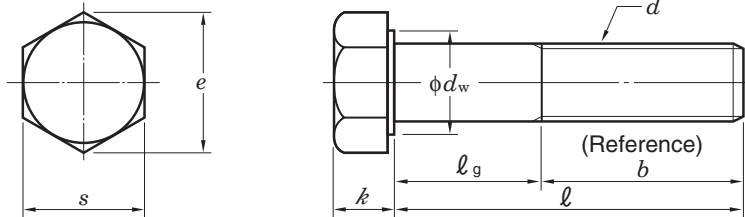

Allowance of bolt length (ℓ)

Unit: mm

Bolt length (ℓ)		Allowance of length
Over	Incl.	
-	80	± 1.5
80	90	± 1.7
90	120	± 1.75
120	180	± 2
180	240	± 2.3
240	300	± 2.6
300	400	± 2.85
400	500	± 3.15

(2) Parts class B M 16–64

Unit: mm

Nominal size of screw d	Coarse screw thread pitch	M 16	(M 18)	M 20	(M 22)	M 24	(M 27)	M 30	(M 33)	M 36	(M 39)	M 42	(M 45)	M 48	(M 52)	M 56	(M 60)	M 64
		Fine thread	M 16 x 1.5	-	M 20 x 1.5	-	M 24 x 2	-	M 30 x 2	-	M 36 x 3	-	M 42 x 3	-	M 48 x 3	-	M 56 x 4	-
		-	(M 18 x 1.5)	(M 20 x 2)	(M 22 x 1.5)	-	(M 27 x 2)	-	(M 33 x 2)	-	(M 39 x 3)	-	(M 45 x 3)	-	(M 52 x 4)	-	(M 60 x 4)	-
Bearing surface dia. d_w (min.)		22	24.85	27.7	31.35	33.25	38	42.75	46.55	51.11	55.86	59.95	64.7	69.45	74.2	78.66	83.41	88.16
Width across flats s (max.)		24	27	30	34	36	41	46	50	55	60	65	70	75	80	85	90	95
Width across corners e (min.)		26.17	29.56	32.95	37.29	39.55	45.2	50.85	55.37	60.79	66.44	71.3	76.95	82.6	88.25	93.56	99.21	104.86
Head height k (basic)		10	11.5	12.5	14	15	17	18.7	21	22.5	25	26	28	30	33	35	38	40
Thread length b (reference)	$\ell \leq 125$	38	42	46	50	54	60	66	-	-	-	-	-	-	-	-	-	-
	$125 < \ell \leq 200$	44	48	52	56	60	66	72	78	84	90	96	102	108	116	-	-	-
	$200 < \ell \leq 500$	-	-	-	69	73	79	85	91	97	103	109	115	121	129	137	145	153

Nominal length ℓ	M 16 Body length ℓ_g (max.)																		
65	(M 18)																		
70	M 20																		
80	(M 22) M 24																		
90	(M 27)																		
100	40 M 30																		
110	50 44																		
120	60 54 (M 33)																		
130	64 58 52 M 36																		
140	74 68 62 56 (M 39)																		
150	84 78 72 66 60 M 42																		
160	116	112	108	104	100	94	88	82	76	70	64	(M 45)	M 48						
180	132 128 124 120 114 108 102 96 90 84 78 72 (M 52)																		
200	148 144 140 134 128 122 116 110 104 98 92 84 M 56																		
220	151 147 141 135 129 123 117 111 105 99 91 83 (M 60)																		
240	161 155 149 143 137 131 125 119 111 103 95 M 64																		
260	181 175 169 163 157 151 145 139 131 123 115 107																		
280	195 189 183 177 171 165 159 151 143 135 127																		
300	215 209 203 197 191 185 179 171 163 155 147																		
320	229 223 217 211 205 199 191 183 175 167																		
340	243 237 231 225 219 211 203 195 187																		
360	263 257 251 245 239 231 223 215 207																		
380	277 271 265 259 251 243 235 227																		
400	291 285 279 271 263 255 247																		
420	311 305 299 291 283 275 267																		
440	325 319 311 303 295 287																		
460	339 331 323 315 307																		
480	359 351 343 335 327																		
500	371 363 355 347																		

As for the bolts with nominal length within this area, standards of continuous thread stud hexagon head bolt (parts class A or B) should be observed.

- Remarks 1. Priority is given to the nominal sizes of screws without parentheses.
- 2. Nominal lengths (ℓ) to be recommended for the nominal sizes of screw are within the range enclosed by bold lines.
- 3. Body length ℓ_g (maximum) should be found by the following formula : ℓ_g (maximum) = Nominal length (ℓ) – Thread length (b)

Appendix Table 16 Hexagon Head Nuts (abstract from JIS B 1181: 1993)

Parts class A M 1.6 – 16
 Parts class B M 18 – 64

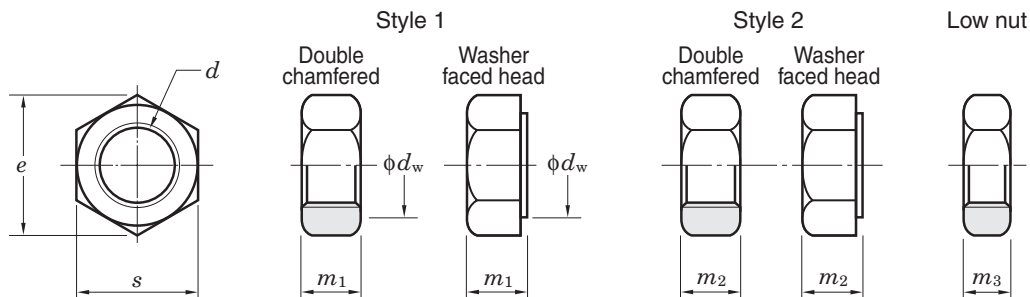

(1) Parts class A M 1.6–16

Unit: mm

Nominal size of screw <i>d</i>	Coarse screw thread pitch	M 1.6	M 2	M 2.5	M 3	(M 3.5)	M 4	M 5	M 6	M 8	M 10	M 12	(M 14)	M 16
	Fine thread	–	–	–	–	–	–	–	–	–	M 8 × 1	M 10 × 1	M 12 × 1.5	–
		–	–	–	–	–	–	–	–	–	(M 10 × 1.25)	(M 12 × 1.25)	(M 14 × 1.5)	–
Bearing surface dia. <i>d_w</i> (min.)		2.27	3.07	4.07	4.57	5.07	5.88	6.88	8.88	11.63	14.63	16.63	19.64	22.49
Width across flats <i>s</i> (max.)		3.2	4	5	5.5	6	7	8	10	13	16	18	21	24
Width across corners <i>e</i> (min.)		3.41	4.32	5.45	6.01	6.58	7.66	8.79	11.05	14.38	17.77	20.03	23.36	26.75
Height	<i>m₁</i> (max.)	1.3	1.6	2	2.4	2.8	3.2	4.7	5.2	6.8	8.4	10.8	12.8	14.8
	<i>m₂</i> (max.)	–	–	–	–	–	–	5.1	5.7	7.5	9.3	12	14.1	16.4
	<i>m₃</i> (max.)	1	1.2	1.6	1.8	2	2.2	2.7	3.2	4	5	6	7	8

Remark Priority is given to the nominal sizes of screws without parentheses.

(2) Parts class B M 18–64

Unit: mm

Nominal size of screw <i>d</i>	Coarse screw thread pitch	(M 18)	M 20	(M 22)	M 24	(M 27)	M 30	(M 33)	M 36	(M 39)	M 42	(M 45)	M 48	(M 52)	M 56	(M 60)	M 64
	Fine thread	–	M 20 × 1.5	–	M 24 × 2	–	M 30 × 2	–	M 36 × 3	–	M 42 × 3	–	M 48 × 3	–	M 56 × 4	–	M 64 × 4
		(M 18 × 1.5)	(M 20 × 2)	(M 22 × 1.5)	–	(M 27 × 2)	–	(M 33 × 2)	–	(M 39 × 3)	–	(M 45 × 3)	–	(M 52 × 4)	–	(M 60 × 4)	–
Bearing surface dia. <i>d_w</i> (min.)		24.85	27.7	31.35	33.25	38	42.75	46.55	51.11	55.86	59.95	64.7	69.45	74.2	78.66	83.41	88.16
Width across flats <i>s</i> (max.)		27	30	34	36	41	46	50	55	60	65	70	75	80	85	90	95
Width across corners <i>e</i> (min.)		29.56	32.95	37.29	39.55	45.2	50.85	55.37	60.79	66.44	71.3	76.95	82.6	88.25	93.56	99.21	104.86
Height	<i>m₁</i> (max.)	15.8	18	19.4	21.5	23.8	25.6	28.7	31	33.4	34	36	38	42	45	48	51
	<i>m₂</i> (max.)	17.6	20.3	21.8	23.9	26.7	28.6	32.5	34.7	–	–	–	–	–	–	–	–
	<i>m₃</i> (max.)	9	10	11	12	13.5	15	16.5	18	19.5	21	22.5	24	26	28	30	32

Remark Priority is given to the nominal sizes of screws without parentheses.

Appendix Table 17 Ball Bearing Units Interchange Guide

17.1 Pillow Block Units

	FYH · JTEKT	ASAHI	NTN
With pressed steel cover	UCP2··C UCP2··CD	UCP2··C UCP2··E	S-UCP2··D1 SM-UCP2··D1
With cast iron cover	UCP2··FC UCP2··FCD UCP3··C UCP3··CD	CUCP2··C CUCP2··CE CUCP3··C CUCP3··CE	C-UCP2··D1 CM-UCP2··D1 C-UCP3··D1 CM-UCP3··D1
Thick Pillow Block Units	UCIP2·· UCIP3··	UCIP2·· UCIP3··	UCIP2·· UCIP3··
Tapped-Base Pillow Block Units	UCPA2··	UCPA2··	UCUP2··D1
High-Base Pillow Block Units	UCPH2··	UCPH2··	UCHP2··D1
Light Pillow Block Units	BLP2·· ALP2··	BLLP··	ASPB2·· AELPB2··
Compact Pillow Block Units	UP0··	UP0··	
Corrosion resistant series Pillow Block Units	UCSP2··H1S6 UCSPA2··H1S6 USPO··S6	MUCP2·· MUCPA2	
Stamped Steel Pillow Block Units	SBPP2·· SAPP2··	BPP··	ASPP2·· AELPP2··

17.2 Flange Units

	FYH · JTEKT	ASAHI	NTN
With pressed steel cover	UCF2··C UCF2··D UCFC2··C UCFC2··D UCFL2··C UCFL2··D	UCF2··C UCF2··E UCFC2··C UCFC2··E UCFL2··C UCFL2··E	S-UCF2··D1 SM-UCF2··D1 S-UCFC2··D1 SM-UCFC2··D1 S-UCFL2··D1 SM-UCFL2··D1
With cast iron cover	UCF2··FC UCF2··FD UCF3··C UCF3··D UCFC2··FC UCFC2··FD UCFS3··C UCFS3··D UCFL2··FC UCFL2··FD UCFL3··C UCFL3··D	CUCF2··C CUCF2··CE CUCF3··C CUCF3··CE CUCFC2··C CUCFC2··CE CUCFS3··C CUCFS3··CE CUCFL2··C CUCFL2··CE CUCFL3··C CUCFL3··CE	C-UCF2··D1 CM-UCF2··D1 C-UCF3··D1 CM-UCF3··D1 C-UCFC2··D1 CM-UCFC2··D1 C-UCFS3··D1 CM-UCFS3··D1 C-UCFL2··D1 CM-UCFL2··D1 C-UCFL3··D1 CM-UCFL3··D1
Adjustable 2-Bolt Flange Units	UCFA2··	UCFA2··	UCFA2··D1
3-Bolt Flange Units	UCFB2··	UCFK2··	UCFH2··D1
Light 2-Bolt Flange Units	BLF2·· ALF2··	BLFL··	ASFB2·· AELFB2··
Compact 2-Bolt Flange Units	UFL0··	UFL0··	
Corrosion resistant series 4-Bolt Flange Units	UCSF2··H1S6	MUCF2	
Corrosion resistant series 2-Bolt Flange Units	UCSFL2··H1S6	MUCFL2··	
Stamped steel plate Flange	SBPF2·· SAPF2·· SBPFL2·· SAPFL2··	BPF·· BPFL··	ASPF2·· AELPF2·· ASPFL2·· AELPFL2··

17.3 Take-Up Units

	FYH · JTEKT	ASAHI	NTN
With pressed steel cover	UCT2·C UCT2·CD	UCT2·C UCT2·E	S-UCT2·D1 SM-UCT2·D1
With cast iron cover	UCT2·FC UCT2·FCD UCT3·C UCT3·CD	CUCT2·C CUCT2·CE CUCT3·C CUCT3·CE	C-UCT2·D1 CM-UCT2·D1 C-UCT3·D1 CM-UCT3·D1
Corrosion resistant series Take-Up Units	UCST2·H1S6	MUCT2	
Take-Up Units with frame	UCTH2····· UCTL2····· UCTU2····· UCTU3·····	UCT2·-WB UCTL2·+WL· UCTU2·+WU· UCTU3·+WU·	UCT2·-D1 UCL2·D1 UCM2·D1 UCM3·D1
Steel Plate Frame Take-Up Units	SBPTH2····· SBNPTH2·····	BTAW201,X	ASPT2·····

17.4 Other Units

	FYH · JTEKT	ASAHI	NTN
Hanger Units	UCHA2·	UCECH2·	UCHB2·D1

17.5 Ball Bearing Inserts

	FYH · JTEKT	ASAHI	NTN
Ball bearing inserts	UC2· UK2· NA2· SB2· SA2·	UC2· UK2· UG2·+ER B·	UC2·D1 UK2·D1 UEL2·D1 AS2· AEL2·
Cylindrical O. D.	RB2· ER2·	UR2· *1 SER2· *1	UCS2·LN *1

*1 Width of the outer ring for these items differs from that of others.

17.6 Special Specification Items

	FYH · JTEKT	ASAHI	NTN
Grease (heat temperature)	D1K2	HR5	HT2
(cold temperature)	D2K2	CR2A	CT1
(heat temperature)	D9K2	HR23	
Non-contact Seal	K3		U
Ductile cast iron	H4		N1
Lubricated type			D1
Non-lubricated type	E4	GOO	



Appendix Table 18 Spherical Roller Bearing Units Interchange Guide

Set Screw Collar Lock 2-Bolt Pillow Block

FYH		DODGE	REXNORD	LB	TIMKEN
UNIT NO.	SHAFT SIZE	PART NUMBERS			
XSE2P408-22	1 ³ / ₈	P2B-S2-106R & EP2B-S2-106R	–	–	–
XSE2P408-23	1 ⁷ / ₁₆	P2B-S2-107R & EP2B-S2-107R	ZA2107 & ZEP2107	PB22423H & PEB22423H	–
XSE2P408-24	1 ¹ / ₂	P2B-S2-108R	ZA2108	PB22424H	–
XSE2P408	40MM	–	–	–	–
XSE2P409-27	1 ¹¹ / ₁₆	P2B-S2-111R & EP2B-S2-111R	ZA2111 & ZEP2111	PB22427H & PEB22427H	–
XSE2P409-28	1 ³ / ₄	P2B-S2-112R	ZA2112	PB22428H	–
XSE2P409	45MM	–	–	–	–
XSE2P410-31	1 ¹⁵ / ₁₆	P2B-S2-115R & EP2B-S2-115R	ZA2115 & ZEP2115	PB22431H & PEB22431H	QAP10A115S & QAPL10A115S
XSE2P410-32	2	P2B-S2-200R & EP2B-S2-200R	ZA2200 & ZEP2200	PB22432H & PEB22432H	QAP10A200S & QAPL10A200S
XSE2P410	50MM	–	ZA2050MM	PB224M50H & PEB224M50H	QAP10A050S & QAPL10A050S
XSE2P411-35	2 ³ / ₁₆	P2B-S2-203R & EP2B-S2-203R	ZA2203 & ZEP2203	PB22435H & PEB22435H	QAP11A203S & QAPL11A203S
XSE2P411	55MM	–	ZA2055MM	PB224M55H & PEB224M55H	QAP11A055S & QAPL11A055S
XSE2P413-39	2 ⁷ / ₁₆	P2B-S2-207R & EP2B-S2-207R	ZA2207 & ZEP2207	PB22439H & PEB22439H	QAP13A207S & QAPL13A207S
XSE2P413-40	2 ¹ / ₂	–	ZA2208 & ZEP2208	PB22440H & PEB22440H	QAP13A208S & QAPL13A208S
XSE2P413	65MM	–	ZA2065MMF & ZEP2065MM	–	QAP13A065S & QAPL13A065S
XSE2P415-43	2 ¹¹ / ₁₆	–	ZEP2211	PEB22443H	QAP15A211S
XSE2P415-44	2 ³ / ₄	–	ZEP2212	PEB22444H	QAP15A212S
XSE2P415-47	2 ¹⁵ / ₁₆	–	ZEP2215	PEB22447H	QAP15A215S
XSE2P415-48	3	–	ZEP2300	PEB22448H	QAP15A300S
XSE2P415	75MM	–	–	PEB224M75H	QAP15A075S
XS2P415-43	2 ¹¹ / ₁₆	P2B-S2-211R & EP2B-S2-211R	ZA2211	PB22443H	QAPL15A211S
XS2P415-44	2 ³ / ₄	–	ZA2212	PB22444H	QAPL15A212S
XS2P415-47	2 ¹⁵ / ₁₆	P2B-S2-215R & EP2B-S2-215R	ZA2215	PB22447H	QAPL15A215S
XS2P415-48	3	P2B-S2-300R & EP2B-S2-300R	ZA2300	PB22448H	QAPL15A300S
XS2P415	75MM	–	–	PB224M75H	QAPL15A075S
XSE2P418-55	3 ⁷ / ₁₆	P2B-S2-307R & EP2B-S2-307R	ZA2307 & ZEP2307	PB22455H & PEB22455H	QAP18A307S & QAPL18A307S
XSE2P418-56	3 ¹ / ₂	–	ZA2308 & ZEP2308	PB22456H & PEB22456H	QAP18A308S & QAPL18A308S
XSE2P418	90MM	–	–	–	QAP18A090S & QAPL18A090S
XSE2P420-63	3 ¹⁵ / ₁₆	–	ZA2315	–	QAP20A315S
XSE2P420-64	4	–	ZA2400	–	QAP20A400S
XSE2P420	100MM	–	–	–	QAP20A100S
XS2P420-63	3 ¹⁵ / ₁₆	P2B-S2-315R	–	PB22463H	QAPL20A315S
XS2P420-64	4	–	–	PB22464H	QAPL20A400S
XS2P420	100MM	–	–	PB224M100H	QAPL20A100S

Set Screw Collar Lock 2-Bolt Pillow Block

FYH		SEALMASTER	BROWNING	MOLINE
UNIT NO.	SHAFT SIZE	PART NUMBERS		
XSE2P408-22	1 ³ / ₈	USRB5000-106	SPB1000 1 ³ / ₈	–
XSE2P408-23	1 ⁷ / ₁₆	USRB5000-107	SPB1000 1 ⁷ / ₁₆	19121107 & 19221107
XSE2P408-24	1 ¹ / ₂	USRB5000-108	SPB1000 1 ¹ / ₂	19121108 & 19221108
XSE2P408	40MM	–	–	–
XSE2P409-27	1 ¹¹ / ₁₆	USRB5000-111	SPB1000 1 ¹¹ / ₁₆	19121111 & 19221111
XSE2P409-28	1 ³ / ₄	USRB5000-112	SPB1000 1 ³ / ₄	19121112 & 19221112
XSE2P409	45MM	–	–	–
XSE2P410-31	1 ¹⁵ / ₁₆	USRB5000-115 & USRBE5000-115	SPB1100 1 ¹⁵ / ₁₆	19121115 & 19221115
XSE2P410-32	2	USRB5000-200 & USRBE5000-200	SPB1100 2	19121200 & 19221200
XSE2P410	50MM	–	–	–
XSE2P411-35	2 ³ / ₁₆	USRB5000-203 & USRBE5000-203	SPB1100 2 ³ / ₁₆	19121203 & 19221203
XSE2P411	55MM	–	–	–
XSE2P413-39	2 ⁷ / ₁₆	USRB5000-207 & USRBE5000-207	SPB1100 2 ⁷ / ₁₆	19121207 & 19221207
XSE2P413-40	2 ¹ / ₂	USRB5000-208 & USRBE5000-208	SPB1100 2 ¹ / ₂	19121208 & 19221208
XSE2P413	65MM	–	–	–
XSE2P415-43	2 ¹¹ / ₁₆	USRBE5000-211	–	–
XSE2P415-44	2 ³ / ₄	USRBE5000-212	–	–
XSE2P415-47	2 ¹⁵ / ₁₆	USRBE5000-215	–	–
XSE2P415-48	3	USRBE5000-300	–	–
XSE2P415	75MM	–	–	–
XS2P415-43	2 ¹¹ / ₁₆	USRB5000-211	SPB1000 2 ¹¹ / ₁₆	19121211 & 19221211
XS2P415-44	2 ³ / ₄	USRB5000-212	SPB1000 2 ³ / ₄	19121212 & 19221212
XS2P415-47	2 ¹⁵ / ₁₆	USRB5000-215	SPB1000 2 ¹⁵ / ₁₆	19121215 & 19221215
XS2P415-48	3	USRB5000-300	SPB1000 3	19121300 & 19221300
XS2P415	75MM	–	–	–
XSE2P418-55	3 ⁷ / ₁₆	USRB5000-307 & USRBE5000-307	SPB1100 3 ⁷ / ₁₆	19121307 & 19221307
XSE2P418-56	3 ¹ / ₂	USRB5000-308 & USRBE5000-308	SPB1100 3 ¹ / ₂	19121308 & 19221308
XSE2P418	90MM	–	–	–
XSE2P420-63	3 ¹⁵ / ₁₆	USRB5000-315 & USRBE5000-315	SPB1100 3 ¹⁵ / ₁₆	19121315 & 19221315
XSE2P420-64	4	USRB5000-400 & USRBE5000-400	SPB1100 4	19121400 & 19221400
XSE2P420	100MM	–	–	–
XS2P420-63	3 ¹⁵ / ₁₆	–	–	–
XS2P420-64	4	–	–	–
XS2P420	100MM	–	–	–





EXTRA
SOLID

NIPPON PILLOW BLOCK CO., LTD.

HEAD OFFICE

2306 Hirao Mihara-ku Sakai Osaka 587-0022 Japan

TEL: +81-72-361-3750 FAX: +81-72-361-4173

www.fyhbearings.com

E-mail: info@fyhbearings.com

INTERNATIONAL DIVISION

E-mail: exports@fyh.co.jp

FYH BEARING UNITS USA INC.

13201 FYH Drive Huntley, Illinois 60142, USA

TEL: +1-847-487-9111 FAX: +1-847-487-9222

E-mail: sales@fyhusa.com

DOMESTIC BRANCHES IN JAPAN

Tokyo

Kase Building 116-5 F 1-3-49 Katsushima Shinagawa Tokyo 140-0012 Japan

TEL: +81-3-5767-7270 FAX: +81-3-5767-7280

E-mail: tokyo@fyh.co.jp

Nagoya

2-1-2 Niban Atsuta-ku Nagoya Aichi 456-0052 Japan

TEL: +81-52-652-1211 FAX: +81-52-652-0744

E-mail: nagoya@fyh.co.jp

Sapporo

E-mail: sapporo@fyh.co.jp

Fukuoka

E-mail: kyusyu@fyh.co.jp

Hiroshima

E-mail: fukuyama@fyh.co.jp



fyhbearings.com





ویرا پرداز آروین پاسارگاد

با مدیریت خانم مهندس احمدی



جهت مشاوره

با کارشناسان فنی

با ما در ارتباط باشید



021 - 91001377



0935 125 90 98