



ویرا پرداز آروین پاسارگاد

با مدیریت خانم مهندس احمدی



جهت مشاوره

با کارشناسان فنی

با ما در ارتباط باشید



021 - 91001377



0935 125 90 98

MCG99

McGILL®

PRECISION BEARINGS



Experience The SM
POWER



EMERSON POWER TRANSMISSION

McGILL®

PRECISION BEARINGS

*Select the bearings
you need from the
complete McGill line*



The McGill precision bearing line has been developed on the basis of providing design simplification and improvement of machine performance. For example, McGill invented the integral stud type CAMROL® cam follower bearing, which eliminated the need for improvised bolt and roller assemblies. SPHERE-ROL® Bearings are available from McGill with NYLAPLATE® seals that provide integral sealing, even where shaft misalignment is present.

The trademarks McGill, CAMROL, CAGEROL, MR, GUIDEROL, LUBRI-DISC, SPHERE-ROL, NYLAPLATE, LAMBDA, TRAKROL, MCFD, MCYRD, MCF, MCFR, MCYR and MCYRR are registered trademarks of Emerson Power Transmission Manufacturing, L. P. and/or McGill Manufacturing Co., Inc. Emerson Power Transmission and McGill Manufacturing are not responsible for printing errors as they may appear in this catalog. Bearing specifications subject to change between reprint issues.

Legal Obligation: Emerson Power Transmission warrants the products manufactured by it to be free from defects in material and workmanship under normal use and service. Refer to complete Standard Terms and Conditions of Sales on page 128.

© Emerson Power Transmission Manufacturing, L.P. 1998, 1999. All Rights Reserved.

General Engineering Section

2-10

Factors influencing bearing selection-load and life factors and calculations (2-5). Shaft and housing fits (6). Lubrication (6-7). Handling and storage (7). A.B.M.A. (7). Bearing weights (8-9). Equivalent charts (10).

Engineering

CAMROL® Cam Follower Bearings

11-56

CAMROL bearing engineering section (11-15). CF Series standard stud (16-24). CFH Series heavy stud (25-29). CYR Series cam yoke rollers (30-31). BCF-S Series and BCYR-S Series bushing type (32-37). CAMROL bearing applications (38-40). Cam follower interchangeability charts (41-43). Metric cam follower engineering section (44-48). Eccentric collar metric cam followers (49). MCF®, MCF-S®, MCFR® and MCFR-S® Series Metric CAMROL® bearings stud type (50-51). MCYR®, MCYR-S®, MCYRR® and MCYRR-S® Metric CAMROL® bearings yoke type (52-53). MCFD Series - Cylindrical rollers/stud type (54). MCYRD Series - cylindrical rollers/yoke type (55). Interchangeability charts (55-56).



CAMROL® Bearings

TRAKROL® Track Roller, Wire Straightener and Guide Bearings

57-60

TRAKROL engineering section (57). PCF Series with plain O.D.s (58-59). VCF Series with V-groove O.D.s (58-59). UCF Series with U-groove O.D.s (58-59). FCF Series with flanged O.D.s (60). TRAKROL interchangeability chart (60).



TRAKROL® Bearings

CAGEROL®, Caged and GUIDEROL® Center-Guided Roller Bearings

61-85

Engineering section (61-63). MR Series CAGEROL® bearings with inner rings (64-65), without inner rings (66). SMR Series CAGEROL® bearings with integral seals and inner rings (67), with integral seals without inner rings (68-69). MT Series GUIDEROL bearings with inner rings (70-71), without inner rings (72). SG Series GUIDEROL® bearings with integral seals and inner rings (73), without inner rings (74-75). MI Series inner races (76-77). Interchangeability charts (78-83). Applications (84-85).

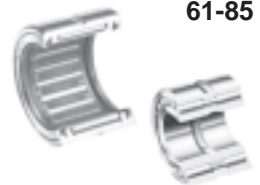

CAGEROL®/GUIDEROL® Bearings

SPHERE-ROL® Spherical Roller Bearings

86-101

SPHERE-ROL bearing engineering section (86-93). SB 22200 Series (94-95). SB 22300 Series (96-97). Spherical roller bearing interchangeability charts (98). SPHERE-ROL bearing applications (99-101).



SPHERE-ROL® Bearings

AIRCRAFT Bearings

102-108

Aircraft bearing engineering information (102). NBF and NBL Series (103). AFC and AL Series (104). NBE and NBK (105). NBC Series (106). NAS Series (107). Interchangeability charts (108).



Aircraft Bearings

Special Engineered-to-the-Application Bearings

109-118

Typical examples (109-118). Band saw guide wheel (109). Back rest rollers (109).



Special Bearings

FACTORS INFLUENCING ROLLER BEARING SELECTION

Introduction

The following general information will serve the purpose of aiding the machine designer or bearing user when applying CAMROL®, CAGEROL®, GUIDEROL®, and SPHERE-ROL® bearings covered by this catalog. Additional data dealing solely with each type of bearing is found in each respective section. Cross references are made whenever necessary. Engineering data should be carefully considered in selecting the proper design and size bearing.

For those applications where unusual or abnormal operating conditions exist, it is advisable to consult the McGill Engineering Department for recommendations. Examples of such conditions requiring special consideration are those involving high or low temperatures, misalignment, shaft and housing fits that might cause the bearing to be too tightly fitted internally after mounting, vibration, moisture, contamination, etc.

Nuclear applications

GOODS AND/OR SERVICES SOLD HEREUNDER ARE NOT FOR USE IN ANY NUCLEAR AND RELATED APPLICATIONS. Buyer accepts goods and/or services with the foregoing understanding, agrees to communicate the same in writing to any subsequent purchaser or users and to defend, indemnify and hold harmless Seller from any claims, losses, suits, judgments and damages, including incidental and consequential damages, arising from such use, whether the cause of action be based in tort, contract or otherwise, including allegations that the Seller's liability is based on negligence or strict liability.

Bearing life

Bearings which have been properly mounted, lubricated, and protected will operate with minimal, if any, internal wear until fatigue of the rings or rolling elements takes place. Fatigue is the first evidence of spalling of the rolling contact surfaces of these parts, and occurs because of the repeated stressing of the contacts.

The "life" of an individual roller bearing is defined as the number of revolutions (or hours at a given constant speed) which the bearing runs before the first evidence of fatigue develops in the material of either ring or of any of the rolling elements. The L_{10} or "rating life" of a group of apparently identical roller bearings is defined as the number of revolutions (or hours at some given constant speed) that 90% of the group of bearings will complete or exceed before the first evidence of fatigue develops.

Load ratings

The basic load rating or Basic Dynamic Rating as defined by the American Bearing Manufacturers Association (ABMA) is that calculated, constant radial load which 90% of a group of apparently identical bearings with stationary outer ring can theoretically endure for a Rating Life of 1 million revolutions. (33 $\frac{1}{3}$ rpm for 500 hours.) The basic load rating is a reference value only, the base value of 1 million revolutions rating life having been chosen for ease of calculation.

It is not anticipated that such bearing loading would normally be applied while the bearing is rotating. Bearings in this catalog should not normally be subjected to dynamic loads greater than 50 percent of the Basic Dynamic Rating. Consult the McGill Engineering Department if such conditions exist. Applications involving reversing radial loads on stud type cam follower bearings should be reviewed by the McGill Engineering Department.

Life calculations

The L_{10} (rating) life for any given application and bearing selection can be calculated in terms of millions of revolutions by using the bearing Basic Dynamic Rating and applied radial load (or, equivalent radial load in the case of applications having combined radial and thrust loads or outer ring rotation). It has been shown by laboratory and field tests that rating life for roller bearings is normally inversely proportional to the $^{10/3}$ power of the load.

Therefore, $L_{10} = \left(\frac{\text{BDR}}{P} \right)^{10/3}$ million revolutions, where

L_{10} is the rating life in millions of revolutions with a constant bearing load P , and BDR is the load which will give a theoretical rating life of one million revolutions and is referred to as Basic Dynamic Rating in this catalog.

The L_{10} life for any given application can be calculated in terms of hours, using the bearing Basic Dynamic Rating, applied load (or equivalent radial load) and suitable speed factors, by the following equation:

$$L_{10} = \frac{16,666}{N} \left(\frac{\text{BDR}}{P} \right)^{10/3}$$

where,

L_{10} = rating life, hours

BDR = Basic Dynamic Rating

P = Constant equivalent radial load

N = speed (RPM)

To determine the Basic Dynamic Rating required for a given application, use the following formula:

$$\text{BDR} = .054 \times P \times (L_{10} \times N)^{-3}$$

Example 1:

To find the theoretical L_{10} life of an MR-16 bearing operating at a speed of 500 RPM and under a load of 1000 pounds:

Basic Dynamic Rating of MR-16 = 8000 pounds.

Use formula:

$$L_{10} = \frac{16.666}{N} \left(\frac{BDR}{P} \right)^{10/3}$$

$$L_{10} = \frac{16.666}{500} \left(\frac{8000}{1000} \right)^{10/3}$$

$$L_{10} = 34,132 \text{ hours.}$$

Example 2:

Find the Basic Dynamic Rating required for a CAGEROL® bearing operating at 1000 RPM, with a load of 700 pounds. The required L_{10} Life will be 20,000 hours.

Use the Formula:

$$BDR = .054 \times P \times (L_{10} \times N)^3$$

$$BDR = .054 \times 700 \times (20,000 \times 1000)^3$$

$$BDR = .054 \times 700 \times 155$$

$$BDR = 5859 \text{ Pounds}$$

Shaft hardness and surface finishes

Where bearing inner races are omitted, the mounting shaft becomes an integral member of the bearing assembly from a fatigue life standpoint. In order to maintain catalog ratings, it is necessary to both harden and finish shafts properly to attain these ratings. Cleanliness of the steel shaft material is also important.

For such applications, a shaft surface hardness of HRC 58 minimum is recommended for both through-hardening and case hardening materials, and in the case of carburizing grade materials, case depths should be sufficient to adequately support the load and contact stresses. For proper bearing operation, a ground shaft surface finish of 12 microinches AA should not be exceeded.

Static load rating

The "static load rating" for roller bearings is that uniformly distributed static radial bearing load which produces a maximum contact stress of 580,000 PSI acting at the center of contact of the most heavily loaded rolling element. At this stress level, plastic deformation begins to be significant. Experience has shown that the plastic deformation at this stress level can be tolerated in most bearing applications without impairment of subsequent bearing operation. In certain applications where subsequent rotation of the bearing is slow and where smoothness and friction requirements are not too exacting, a higher static load limit can be tolerated. Where extreme smoothness is required or friction requirements are critical, a lower static load limit may be necessary.

FACTORS INFLUENCING ROLLER BEARING SELECTION

Bearing friction

Coefficient of friction of bearings listed in this catalog are as follows:

CAMROL® Bearings010
GUIDEROL® Bearings004
CAGEROL® Bearings002
SPHERE-ROL® Bearings0018

These values are based on normal operating conditions, i.e., favorable mounting and lubrication. Furthermore, these coefficients refer to the radius of the bearing bore. (Radius of roller OD for CAMROL®.)

Bearing selection for applications involving variable loads

Many bearing applications involve varying loads which are not constant at any given speed. In cases such as this, often times bearing selection is made on the basis of the maximum operating conditions rather than a weighted average loading condition.

In any application where the load varies or the load and speed both vary, it is more economical to select a bearing based on the root mean load formula at mean speed. The following equations apply to any application for which the magnitude of load can be determined for various increments of time, and also where speed can be determined for various increments of time.

Root mean load formula:

The following formula is to be used wherever a number of varying loads are applied to a bearing for varying time limits. Maximum loading must be considered for bearing size selection.

$$RML^* = \sqrt[10/3]{\frac{(L_1^{10/3}N_1) + (L_2^{10/3}N_2) + (L_3^{10/3}N_3)}{100}}$$

Where:

RML = Root Mean Load

L₁, L₂, etc. = Loads in Pounds

N₁, N₂, etc. = Percent of total time operated at loads L₁, L₂, etc.

* Apply RML to Rating at mean speed to determine resultant life.

$$MEAN\ SPEED = \frac{S_1N_1 + S_2N_2 + S_3N_3}{100}$$

S₁, S₂, etc. = Speeds in RPM

N₁, N₂, etc. = Percent of total time operated at speeds S₁, S₂, etc.

Bearing life in oscillating applications

ERS = Equivalent Rotative Speed

N = Total number of degrees per minute through which the bearing will rotate.

$$ERS = \frac{N}{360}$$

The equivalent rotative speed (ERS) is then used as the bearing operating speed in the calculation of the L₁₀ (Rating) Life as described on pages 2 and 3. The above formula is based on sufficient angular rotation to have roller paths overlap.

In the above formula, allowance is made for the total number of stress applications on the weakest race per unit time, which, in turn, determines fatigue life and the speed factors. The theory behind fretting corrosion is best explained by the fact that the rolling elements in small angles of oscillation retrace a path over an unchanging area of the inner or outer races where the lubricant is prevented by inertia from flowing in behind the roller as the bearing oscillates in one direction. Upon reversal, this small area of rolling contact is traversed by the same roller in the dry state.

The friction of the two unlubricated surfaces causes fretting corrosion and produces failures which are unpredictable from a normal life standpoint.

With a given bearing selected for an oscillating application, the best lubrication means is a light mineral oil under positive flow conditions. With a light oil, there is a tendency for all areas in the bearing load zone to be immersed in lubricant at all times. The full flow lubrication dictates that any oxidized material which may form is immediately carried away by the lubricant, and since these oxides are abrasive, further wear tends to be avoided.

If grease lubrication must be used, it is best to consult with either the bearing manufacturer or the lubricant manufacturer to determine the best possible type of lubricant. Greases have been compounded to resist the detrimental effect of fretting corrosion for such applications.

Type of load

The load ratings in this catalog are based on uniform and steady loading. When the loading is of a shock nature and/or vibration is present, or the loading is indeterminate, a bearing of greater rating must be selected. If such conditions exist, it is advisable to use the application Type of Load Factor as shown in the table below. These factors apply for CAMROL®, TRAKROL®, GUIDEROL® and CAGEROL® bearings.

Type of load factors

TYPE OF LOAD	FACTOR c
Uniform and Constant	1.0
Light Shock	1.5
Moderate Shock	2.0
Heavy Shock	3.0

The actual bearing load should be multiplied by the appropriate load factor and the resultant value used to calculate the bearing life or to determine the required basic dynamic rating (BDR) as described on pages 2 and 3.

Design considerations for matched bearings

Where bearings are mounted so that the distance between them is less than the width of one bearing, it is recommended under heavy loading conditions to provide some degree of diametral matching in order to prevent unequal sharing of the applied load.

Matching procedures have been developed to provide super precision matching of bearings.

Bearings matched in this category are identified by "-DS" suffix for super precision.

- A. O.D. and I.D., where applicable, of matched bearings same diameters within 30% of the respective O.D. or I.D. tolerance.
- B. I.D. of rollers or diametral clearance, where applicable, of matched bearings same within 30% of the tolerance range.
- C. Radial runout of matched bearings same within 20% of the tolerance range.
- D. High point of radial runout marked on the face of each outer and inner ring.
- E. Matched bearings to be packaged as a unit.

MATCHING FACTOR		MATCHING SUFFIX
CAGEROL® & GUIDEROL®	SPHERE-ROL®	
1.37	1.55	None
1.65	1.71	"-DS"

Multiply Matching Factor by rating of single bearing to obtain resultant rating for pair or combination of bearings.

Effect of elevated temperature on bearing rating

As temperature rises, bearing rating is reduced, depending upon the bearing material and the operating temperature. Various types of tool steel, stainless steel and some of the more exotic materials are being used in order to meet the need for bearings to operate at elevated temperatures.

The graph shows the experimental relative bearing ratings of various common materials at elevated temperatures, and gives the percentage of bearing rating retained at various temperatures compared to a bearing having a minimum hardness of 58 HRC at room temperature. Consult McGill Engineering Department for materials or temperatures not shown.

- 1. M-50 Tool Steel - 0.80C 4.25M_O 4.10C_R 1.10V
- 2. M-2 Tool Steel - 0.85C 6.30W 5.05M_O 4.15C_R 1.85V
- 3. M-10 Tool Steel - 0.87C 8.00M_O 4.00C_R 1.90V
- 4. 440-C Stainless Steel
- 5. S.A.E. 52100 Bearing Steel

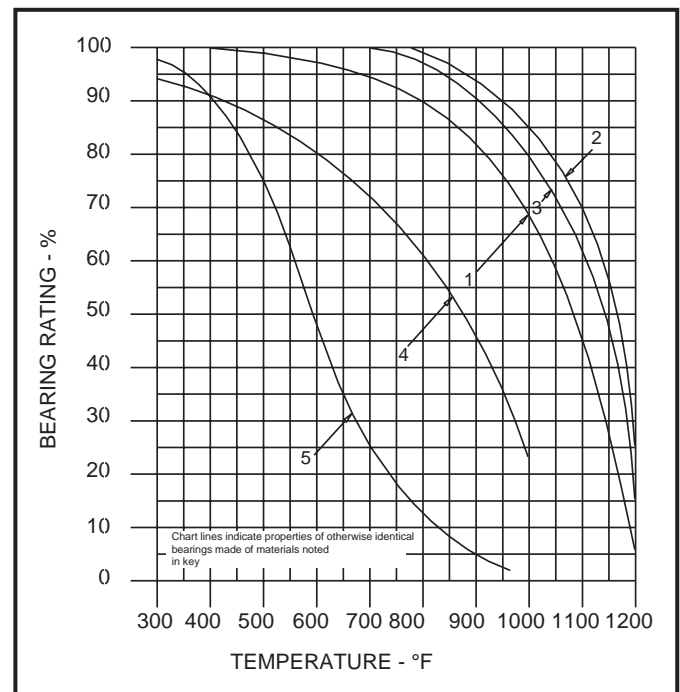

Note - 100% represents the rating of a bearing having a minimum hardness of 58HRC at room temperature.

APPLICATION CONSIDERATIONS

The proper selection and application of power transmission products and components, including the related area of product safety, is the responsibility of the customer. Operating and performance requirements and potential associated issues will vary appreciably depending upon the use and application of such products and components. The scope of the technical and application information included in this publication is necessarily limited. Unusual operating environments and conditions, lubrication requirements, loading supports, and other factors can materially affect the application and operating results of the products and components and the customer should carefully review its requirements. Any technical advice or review furnished by Emerson Power Transmission Corporation and its divisions with respect to the use of products and components is given in good faith and without charge, and Emerson assumes no obligation or liability for the advice given, or results obtained, all such advice and review being given and accepted at customer's risk.

For a copy of our **Standard Terms and Conditions of Sale, Disclaimers of Warranty, Limitation of Liability and Remedy**, please contact McGill customer service, 1-219-465-2200. These terms and conditions of sale, disclaimers and limitations of liability apply to any person who may buy, acquire or use an Emerson Power Transmission Corporation product referred to herein, including any person who buys from a licensed distributor of these branded products.

FACTORS INFLUENCING ROLLER BEARING SELECTION**Shaft and housing fits**

Fit selections given in the various sections will serve as a guide for the majority of applications where the bearings are subjected to normal or heavy loads and other normal operating conditions. When bearings are subjected to very heavy or vibratory loads it may be necessary to employ shaft and housing fits tighter than standard. The same applies if shafts or housings of soft metal or those not having smoothly ground bearing seats (i.e., the smoothness ordinarily associated with ground or reamed bores) are used.

Furthermore, if speeds are abnormally high, it may be necessary to maintain shaft and housing fits other than those shown in tables. Consult our Engineering Department for recommendations for these abnormal conditions.

Lubrication

Bearings may be grease or oil lubricated, depending on a number of conditions, such as: type of sealing, load, amount and type of contamination, and amount and type of moisture present, temperature, and friction requirements.

Lithium soap grease

For grease lubrication, lithium soap base greases are preferred for needle bearings in general because of their ability to stand up under churning action of rollers in a confined space. These greases are not channeling types, therefore provide constant lubrication for roller contact surfaces. They are also insoluble in water. Operating temperatures vary from -30°F. to +250°F. for No. 1 consistency lithium soap base grease which should be ideal for GUIDEROL® or CAGEROL® bearings. For CAMROL® or SHPERE-ROL® bearings, a No. 2 consistency is desired.

Sodium soap grease

Sodium soap greases are suitable for many applications since they do have a relatively broad useful operating temperature range. However, they are generally restricted to the lower operating speeds because they are typically fibrous and more adhesive than other grease types. Because of this, they resist throw-off, but the fibrous texture causes higher operating temperatures than lithium or calcium soap greases. Very small amounts of water can be absorbed by sodium soap greases, which may be an advantage in some applications; however, this type grease will be washed away if excessive water is present. Stan-

ard operating temperature range is approximately -10°F. to +200°F.

Calcium soap grease

Calcium soap greases have been used for many years and are often still used because they are water resistant. They are smooth textured and have good mechanical stability, but are limited to lower operating temperatures than lithium or sodium soap greases. Maximum standard operating temperature may be limited to approximately 150°F.

Oil Lubrication

Since oils are considerably more uniform in their characteristics than greases, their selection is much easier. The primary requirement, following viscosity, is a high grade mineral oil — not animal or vegetable oils which have a tendency to deteriorate. The oil must be resistant to oxidation, gumming and evaporation so that viscosity assumes the important role.

For extremely low starting temperatures, an oil must be selected which has a sufficiently low pour point so the bearing will not be locked by stiff oil.

The oil level should normally be maintained at the center of the lower-most rolling element when the bearing is stationary. An over supply of lubricant causes excessive churning action and can lead to heat generation.

Oils of varying viscosity may be selected, depending on application conditions. Oil lubrication is ideal for all CAGEROL®, GUIDEROL®, CAMROL® and SPHERE-ROL® bearings where proper sealing can be employed.

Selection of oil viscosity for rolling element bearing applications is normally dependent on bearing size, speed, load and operating temperature. Method of lubrication may also affect the selected oil viscosity. With these factors known, selection of proper oil viscosity can be made on the basis of elastohydrodynamic analysis, which can be provided by the McGill Engineering Department. A general rule is to maintain the lubricating oil viscosity for needle and roller bearings in the 100-150 SUS range, this being the oil viscosity at the bearing operating temperature. The general rule for ball bearings is approximately 70 SUS viscosity at the operating temperature.

Handling and storage of bearings

Cleanliness and accuracy are stressed in all phases of bearing manufacture to insure a clean and precise mechanical instrument. It is therefore essential the same care be taken in subsequent shipping, storage, and handling, as well as in mounting to make sure of the ultimate in bearing performance.

After completion, each bearing is thoroughly cleaned, preserved and packaged in a shipping carton with proper identification.

Excelsior or sawdust should never be used to cushion cartons of bearings in shipping containers. Such material may contaminate the bearings. Crumpled newspaper or lint-free commercial packing or batting material may be used. The wrappings should never be removed from bearings until they are ready to be mounted. For those bearings preserved with a protective neutral compound, it is generally unnecessary to remove this coating as it will normally mix with any type lubricant.

When necessary to keep bearings in storage, they should be placed in a dry, cool location, and provision should be made to utilize the old stock before using new stock.

ABMA

These letters refer to American Bearing Manufacturers' Association - an organization comprised of the leading manufacturers in the United States. The main purpose of the ABMA is to bring about standardization within the industry and to pass these benefits on to the bearing users. In the ensuing pages reference is made to ABMA bearing numbers. These have been designated as standard numbers for the industry.

Nomographs for Life and Speed Factors

Note: The formulae and nomographs shown below are added to show methods for life calculations as used in previous catalog editions. The end results are the same as would be obtained by the formulae shown in the general engineering section of this catalog, however the nomographs offer an alternate method of calculation.

The L_{10} (rating) life for any given application can be calculated in terms of hours, using the Basic Dynamic Rating, applied load (or equivalent radial load) and suitable speed factors, by the following equation:

$$L_{10} = 500 \left(\frac{BDR}{P \times F_s} \right)^{10/3}$$

where,

L_{10} = rating life, hours

BDR = Basic Dynamic Rating

P = Constant equivalent radial load

F_s = a speed factor (see below)

The rating life in hours can also be determined through the use of a life factor, F_L :

$$L_{10} = 500(F_L)^{10/3}$$

$$\text{Where, } F_L = \frac{BDR}{P \times F_s}$$

Thus, for life calculation in terms of hours: $F_L = \left(\frac{L_{10}}{500} \right)^{0.3}$

To assist the bearing user, the graph (below) shows life factors and corresponding L_{10} (rating life in hours). Life information for other than L_{10} (10% failure or 90% reliability) basis can be provided by the McGill Engineering Department.

The speed factor, F_s , used in the following equations is based on the fact that bearing fatigue life in hours is inversely proportional to the speed. The equation for determining the speed factor for roller bearings is:

$$F_s = (.03 N)^{0.3} \text{ where, } F_s = \text{speed factor and } N = \text{RPM}$$

A graph of bearing speed in RPM and corresponding value of the speed factor (F_s) is included below. Applications having speed factors less than 1.0 should be referred to McGill for further evaluation.

Note: Consult McGill Engineering Department for limiting speeds.

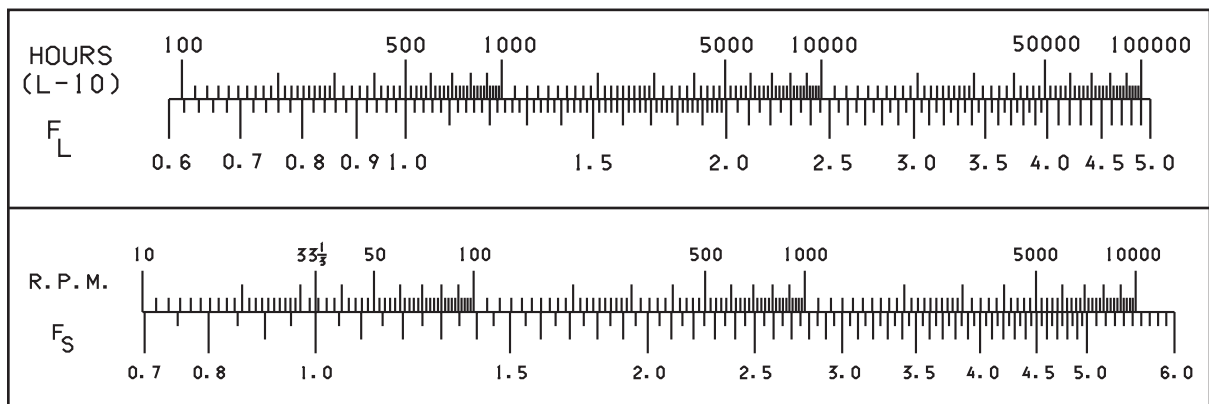

APPROXIMATE BEARING WEIGHT IN POUNDS

CAMROL® BEARINGS			
NO.	CF & CF-S WT.	CFH & CFH-S WT.	CYR & CYR-S WT.
1/2	.04	.04	-
9/16	.04	.04	-
5/8	.05	.05	-
11/16	.06	.06	-
3/4	.07	.08	.06
7/8	.09	.11	.08
1	.17	.20	.15
1 1/8	.19	.24	.17
1 1/4	.30	.38	.24
1 3/8	.35	.44	.30
1 1/2	.53	.69	.41
1 5/8	.60	.75	.50
1 3/4	.84	1.00	.64
1 7/8	.95	1.15	.80
2	1.36	1.56	1.05
2 1/4	1.65	1.88	1.32
2 1/2	2.50	2.75	1.80
2 3/4	2.93	3.19	2.25
3	4.20	4.56	3.10
3 1/4	4.81	5.19	3.62
3 1/2	6.42	7.01	4.95
4	9.46	10.83	7.05
5	19.60	22.10	14.34
6	32.73	36.41	20.16
7	54.73	68.03	32.43
8	79.80	-	47.30
9	111.60	-	65.70
10	148.20	-	89.20

TRAKROL® BEARINGS		
NO.	PCF WT.	FCF WT.
1 1/2	.50	.63
1 3/4	.81	1.00
2	1.31	1.81
2 1/4	1.75	2.06
2 1/2	2.31	2.75
2 3/4	2.75	3.25
3	4.00	4.69
3 1/4	4.75	5.42
3 1/2	5.50	6.25
4	7.13	7.94
4 1/2	9.00	9.88
5	19.00	18.50
6	28.00	30.00
7	36.00	38.00
8	46.00	49.00

GUIDEROL® - CAGEROL® OUTER RING AND ROLLER ASSEMBLY			
NO.	WT.	NO.	WT.
10-N	.12	36	1.32
10	.15	40-N	1.23
12-N	.14	40	1.44
12	.17	44-N	1.36
14-N	.16	44	1.59
14	.21	48-N	1.53
16-N	.20	48	1.70
16	.23	52	2.64
18-N	.24	56-N	2.88
18	.32	56	3.18
20-N	.27	60	3.38
20	.34	64	3.56
22-N	.31	68	3.74
22	.36	72	7.13
24-N	.41	80	7.78
24	.47	88-N	10.40
26-N	.46	88	11.82
26	.51	96-N	11.08
28-N	.47	96	12.69
28	.55	104-N	11.85
29	.57	104	13.55
30	.59	116	19.32
31	.60	124	19.80
32-N	.55	132	21.63
32	.61	140	22.73
36-N	1.13	148	24.00

SPHERE-ROL® BEARINGS					
NO.	WT.	NO.	WT.	NO.	WT.
SB-22204	.28	SB-22222	15.90	SB-22308	2.30
SB-22205	.40	SB-22224	19.80	SB-22309	3.10
SB-22206	.64	SB-22226	24.80	SB-22310	4.10
SB-22207	.95	SB-22228	31.30	SB-22311	5.30
SB-22208	1.20	SB-22230	39.50	SB-22312	6.60
SB-22209	1.30			SB-22313	7.80
SB-22210	1.40			SB-22314	9.50
SB-22211	1.90			SB-22315	11.90
SB-22212	2.60			SB-22316	13.90
SB-22213	3.40			SB-22317	16.20
SB-22215	3.90			SB-22318	19.20
SB-22216	4.60			SB-22319	22.70
SB-22217	5.90			SB-22320	28.40
SB-22218	7.50				
SB-22219	9.20				
SB-22220	11.10				

GUIDEROL® - CAGEROL® INNER RING ONLY			
NO.	WT.	NO.	WT.
MI-6-N	.05	MI-30	.85
MI-7-N	.04	MI-31	.97
MI-8-N	.05	MI-32-N	.74
MI-9-N	.04	MI-32	.87
MI-8	.06	MI-34	1.00
MI-10-N	.06	MI-35	1.06
MI-10	.08	MI-36-N	.83
MI-11-N	.05	MI-36	.97
MI-12-N	.07	MI-38	1.28
MI-12	.10	MI-39	1.05
MI-13	.11	MI-40-N	.92
MI-14-N	.11	MI-40	1.07
MI-14	.13	MI-42	1.12
MI-15-N	.11	MI-44	1.17
MI-15	.12	MI-46	1.30
MI-16-N	.13	MI-47	1.58
MI-16	.16	MI-48-N	1.32
MI-17	.16	MI-48	1.43
MI-18-N	.14	MI-50	1.88
MI-18	.17	MI-52	1.52
MI-19	.24	MI-54	2.04
MI-20-N	.19	MI-56	1.63
MI-20	.22	MI-58	1.70
MI-21-N	.20	MI-60	1.75
MI-21	.26	MI-62	3.25
MI-22	.32	MI-64	4.38
MI-23	.27	MI-68	5.24
MI-24-N	.18	MI-72	5.97
MI-24	.22	MI-80-N	5.93
MI-25	.30	MI-80	7.12
MI-25-4S	.27	MI-88-N	6.30
MI-26-2S	.30	MI-88	7.56
MI-26-N	.30	MI-96	11.06
MI-26	.38	MI-104	11.90
MI-27	.32	MI-112	12.70
MI-28-N	.63	MI-120	13.60
MI-28	.74	MI-128	14.40

AIRCRAFT BEARINGS			
AFC BEARINGS		AL BEARINGS	
NO.	WT.	NO.	WT.
3AFC512	.027	4AL1214	.106
4AFC614	.047	6AL1618	.206
6AFC817	.088	8AL2022	.416
8AFC1021	.171	10AL2426	.693
10AFC1224	.262	12AL2830	1.080
12AFC1628	.493	14AL3234	1.550
14AFC1832	.695	16AL3638	2.150
20AFC2040	1.060	20AL4044	3.090
24AFC2448	2.070	24AL4448	3.820
28AFC2455	2.710	28AL4855	5.400
32AFC2462	3.420	32AL4862	6.800
36AFC2469	4.230		
40AFC2476	5.140		
44AFC2480	5.490		

AIRCRAFT BEARINGS			
NBF, NBL BEARINGS MIL-G-23827 GREASE		NBC BEARINGS	
NO.	WT.	NO.	WT.
3NBF512YJ	.029	3NBC511ZP	.028
4NBF614YJ	.049	4NBC612ZP	.040
6NBF817YJ	.098	5NBC713ZP	.057
8NBF1021YJ	.178	6NBC914YZP	.075
10NBF1224YJ	.266	7NBC1015ZP	.097
12NBF1628YJ	.495	8NBC1218YZP	.165
14NBF1832YJ	.713	9NBC1419YZP	.207
20NBF2040YJ	1.060	10NBC1620YZP	.252
24NBF2448YJ	2.070	12NBC1822YZP	.336
28NBF2455YJ	2.710	14NBC2026YZP	.423
32NBF2462YJ	3.420	16NBC2028YZP	.510
36NBF2469YJ	4.230	20NBC2032YZP	.600
40NBF2476YJ	5.140	24NBC2036YZP	.710
44NBF2480YJ	5.490	28NBC2040YZP	.780
6NBL1618YJ	.228	32NBC2044YZP	.880
8NBL2022YJ	.416	36NBC2048YZP	.980
10NBL2426YJ	.693	40NBC2052YZP	1.060
12NBL2830YJ	1.080	44NBC2056YZP	1.150
14NBL3234YJ	1.550	48NBC2060YZP	1.240
16NBL3638YJ	2.150	52NBC2064YZP	1.340
20NBL4044YJ	3.090	56NBC2070YZP	1.730
24NBL4448YJ	3.820	60NBC2074YZP	1.840
28NBL4855YJ	5.400	64NBC2078YZP	1.990
32NBL4862YJ	6.800		

AIRCRAFT BEARINGS			
MS BEARINGS MIL-G-81322 GREASE		NBE, NBK BEARINGS	
NO.	WT.	NO.	WT.
MS 24465 3	.029	3NBE514ZP	.041
MS 24465 4	.049	4NBE615ZP	.053
MS 24465 6	.098	5NBE717ZP	.079
MS 24465 8	.178	6NBK919YZP	.130
MS 24465 10	.266	7NBK1021YZP	.174
MS 24465 12	.495	8NBK1224YZP	.293
MS 24465 14	.713	9NBK1427YZP	.420
MS 24465 20	1.060	10NBK1628YZP	.520
MS 24466 6	.228	12NBK1830YZP	.630
MS 24466 8	.416	14NBK2034YZP	.870
MS 24466 10	.693	16NBK2036YZP	.960
MS 24466 12	1.080	20NBK2040YZP	1.070
MS 24466 14	1.550	24NBK2044YZP	1.230
MS 24466 16	2.150	32NBK2052YZP	1.490
		40NBK2060YZP	1.780
		48NBK2068YZP	2.060
		56NBK2078YZP	2.650

HRS BEARINGS	
HIGH STRENGTH STUD NO.	WT. - POUNDS MAXIMUM
HRS1	.014 + GRIP LENGTH NUMBER X .0005
HRS2	.031 + GRIP LENGTH NUMBER X .0009
HRS3	.043 + GRIP LENGTH NUMBER X .0014
HRS4	.081 + GRIP LENGTH NUMBER X .0020
HRS5	.125 + GRIP LENGTH NUMBER X .0026
HRS6	.190 + GRIP LENGTH NUMBER X .0035

EQUIVALENT CHARTS

FRACTIONAL INCHES, DECIMAL INCHES AND MILLIMETERS					
MILLIMETERS	DECIMAL INCHES	FRACTIONAL INCHES	MILLIMETERS	DECIMAL INCHES	FRACTIONAL INCHES
.3969 .7938 1.0000	.015625 .03125 .03937	1/64 1/32	13.0969 13.4938 13.8906 14.0000	.515625 .53125 .546875 .55118	33/64 17/32 35/64
1.1906 1.5875 1.9844 2.0000	.046875 .0625 .078125 .07874	3/64 1/16 5/64	14.2875 14.6844 15.0000	.5625 .578125 .59055	9/16 37/64
2.3812 2.7781 3.0000	.09375 .109375 .11811	3/32 7/64	15.0812 15.4781 15.8750 16.0000	.59375 .609375 .6250 .62992	19/32 39/64 5/8
3.1750 3.5719 3.9688 4.0000	.1250 .140625 .15625 .15748	1/8 9/64 5/32	16.2719 16.6688 17.0000	.640625 .65625 .66929	41/64 21/32
4.3656 4.7625 5.0000	.171875 .1875 .19685	11/64 3/16	17.0656 17.4625 17.8594 18.0000	.671875 .6875 .703125 .70866	43/64 45/64 11/16
5.1594 5.5562 5.9531 6.0000	.203125 .21875 .234375 .23622	13/64 7/32 15/64	18.2562 18.6531 19.0000	.71875 .734375 .74803	23/32 47/64
6.3500 6.7469 7.0000	.25 .265625 .27559	1/4 17/64	19.0500 19.4469 19.8434 20.0000	.75 .765625 .78125 .7874	3/4 49/64 25/32
7.1438 7.5406 7.9375 8.0000	.28125 .296875 .3125 .31496	9/32 19/64 5/16	20.2406 20.6375 21.0000	.796875 .8125 .82677	51/64 13/16
8.3344 8.7312 9.0000	.328125 .34375 .35433	21/64 11/32	21.0344 21.4312 21.8281 22.0000	.828125 .84375 .859375 .86614	53/64 27/32 55/64
9.1281 9.5250 9.9219 10.0000	.359375 .3750 .390625 .3937	23/64 3/8 25/64	22.2250 22.6219 23.0000	.8750 .890625 .90551	7/8 57/64
10.3188 10.7156 11.0000	.40625 .421875 .43307	13/32 27/64	23.0188 23.4156 23.8125 24.0000	.90625 .921875 .9375 .94488	29/32 59/64 15/16
11.1125 11.5094 11.9062 12.0000	.4375 .453125 .46875 .47244	7/16 29/64 15/32	24.2094 24.6062 25.0000	.953125 .96875 .98425	61/64 31/32
12.3031 12.7000 13.0000	.484375 .5 .51181	31/64 1/2	25.0031 25.4000	.984375 1.0	63/64

DECIMAL INCHES AND MILLIMETERS					
MM. INCHES	MM. INCHES	MM. INCHES	MM. INCHES	MM. INCHES	MM. INCHES
26 = 1.02362	41 = 1.61417	56 = 2.20472	71 = 2.79527	86 = 3.38582	96 = 3.77952
27 = 1.06299	42 = 1.65354	57 = 2.24409	72 = 2.83464	87 = 3.42519	97 = 3.81889
28 = 1.10236	43 = 1.69291	58 = 2.28346	73 = 2.87401	88 = 3.46456	98 = 3.85826
29 = 1.14173	44 = 1.73228	59 = 2.32283	74 = 2.91338	89 = 3.50393	99 = 3.89763
30 = 1.18110	45 = 1.77165	60 = 2.36220	75 = 2.95275	90 = 3.54330	100 = 3.93700
31 = 1.22047	46 = 1.81102	61 = 2.40157	76 = 2.99212	91 = 3.58267	
32 = 1.25984	47 = 1.85039	62 = 2.44094	77 = 3.03149	92 = 3.62204	
33 = 1.29921	48 = 1.88976	63 = 2.48031	78 = 3.07086	93 = 3.66141	
34 = 1.33858	49 = 1.92913	64 = 2.51968	79 = 3.11023	94 = 3.70078	
35 = 1.37795	50 = 1.96850	65 = 2.55905	80 = 3.14960	95 = 3.74015	
36 = 1.41732	51 = 2.00787	66 = 2.59842	81 = 3.18897		
37 = 1.45669	52 = 2.04724	67 = 2.63779	82 = 3.22834		
38 = 1.49606	53 = 2.08661	68 = 2.67716	83 = 3.26771		
39 = 1.53543	54 = 2.12598	69 = 2.71653	84 = 3.30708		
40 = 1.57480	55 = 2.16535	70 = 2.75590	85 = 3.34645		

Note: American Standards Association Conversion Factor - 1 inch = 25.4 mm.

General

McGill engineers recognized the need for an anti-friction cam follower and developed the first full-type needle roller bearing cam follower over 50 years ago. Although others have copied the outward appearance of CAMROL® bearings, McGill, however, has the advantage of years of application experience in improving the design and devising methods of manufacturing that have built performance extras into both the stud and yoke type roller followers.

The CAMROL® cam follower bearing from McGill is designed and built for withstanding the intermittent shock and loads of cam operation.

Full-type roller bearing construction gives the CAMROL® CF bearing the ultimate in radial capacity, improving its load-carrying qualities to complement its resistance to shock. A soft stud stem adds toughness and permits reworking for slight dimensional changes. Holes through either side or ends of the stud provide for convenient relubrication.

Both zone and through-hardening are used to provide the right combination of hardness and toughness for bearing performance. Hardness is obtained without brittleness that would rob the bearing of its effectiveness in absorbing the shock of cam operation.

Parts are cleaned, assembled and greased under clean conditions to give you extra performance.

Application

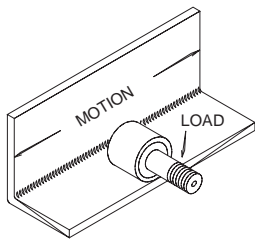

Track or load support rollers to provide anti-friction linear motion.

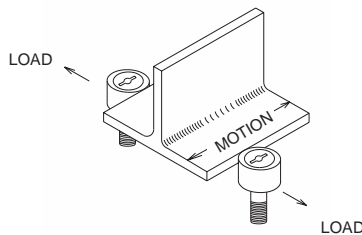

Track guide rollers — to insure free and accurate lateral location during linear motion.

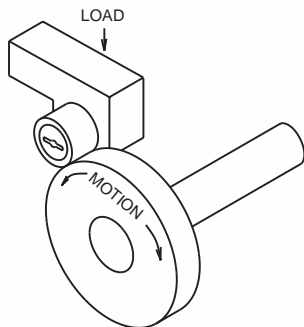

External cam applications — precise, anti-friction translation of motion.

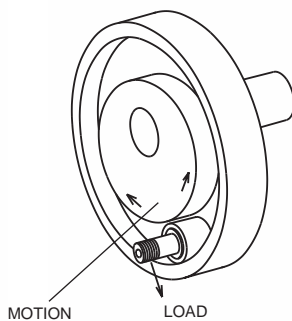

Internal cam applications.

Both cam follower and cam yoke roller-type bearings may be mounted interchangeably from an application standpoint and the usage of either series will depend upon preference for either straddle or yoke mountings which would dictate the use of a cam yoke roller bearing, or else the cantilever or overhung mounting which would dictate the usage of the stud mounted cam follower. In general, heavier loads may be supported by the cam yoke roller bearing where the yoke mounting arrangement is possible, since the problem of stud deflection is eliminated and the ultimate shear strength of the pin on which the cam yoke bearing is mounted becomes the governing factor from a load-carrying standpoint. In most cases, the cam follower construction is preferred due to the greater simplicity of mounting, since the user need merely to drill and ream a suitable mounting hole in the support housing for application of the cam follower bearing.

Both cam followers and cam yoke rollers form a low-cost, readily available, easily mounted bearing for follower arms, guide rollers, table support bearings, and many other applications involving either linear movement or the translation of rotary motion to axial motion. Due to the accuracy of manufacture, bearings can easily be mounted in multiples, providing hole locations are maintained for table support rollers with resultant adequate load sharing properties. Where greater accuracy is required, it is possible to select catalog bearings to closer control limits, and where extreme accuracy of mounting is required, it is possible to mount the cam follower stud in an auxiliary eccentric bushing, which, in turn, is mounted in the support member; and with this modification, the load sharing capabilities is gained in multiple bearing arrangements.

In the application of cam yoke roller bearings, several mounting arrangements are possible, as illustrated below.

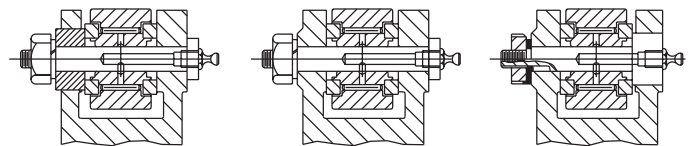

Yoke Mountings

These mountings are straight forward and show the bearings clamped endwise in each case. It is possible to apply bearings of this type without resorting to endwise clamping; however, as noted in mounting instructions on page 14, the endwise clearance over the end plate should be controlled closely to avoid disassembly of the bearing.

ENGINEERING SECTION

Track design

Since either cam followers or cam yoke rollers are merely one component of a two-piece bearing construction involving (1) the cam follower or cam yoke roller and (2) the track or cam on which it operates, some consideration must be given to selection of track or cam materials, since they must be considered bearing components and have a direct effect upon ultimate life and performance of the cam roll application.

From the standpoint of track design where bearings are used as support or guide rollers, it is often difficult to obtain high hardness and tensile strength values for the machine members against which the bearings operate. In most applications in the interest of economy relatively soft structural materials can be applied, and where dimensional accuracy is not extremely critical, the work hardening of ferrous, low carbon track materials, accompanied by relatively small amounts of wear-in of the bearing into the track surface generally results in satisfactory bearing performance. It is common, for instance, in the application of cam follower or cam yoke roller bearings as lift truck mast rollers to employ formed structural steel sections as bearing track support members, and the wearing-in and work hardening of the track surface generally results in a satisfactory bearing application, providing loads are not excessive.

Track capacity

Track capacity of all cam follower and cam yoke roller bearings is the load which a steel track of a given tensile strength will withstand without plastic deformation or brinelling of the track surface. The following tables list track capacities and track capacity factors for steel tracks, as applied to all cam follower and cam yoke roller bearings except crowned O.D. versions. The track capacities for the crowned O.D. versions are 80 percent of the values listed in Table II.

To obtain track capacities for a track hardness other than 40 Rockwell "C" Scale (180,000 psi tensile strength), multiply the track capacity factor listed in Table I by the track capacity listed in Table II. However, regardless of the resulting track capacity, the bearings must not be dynamically loaded over $1/2$ the Basic Dynamic Rating or statically loaded over the Maximum Static Capacity listed for that bearing.

Table I

TRACK TENSILE STRENGTH PSI.	TRACK HARDNESS ROCKWELL "C"	TRACK CAPACITY FACTOR
120,000	26	.445
140,000	32	.607
160,000	36	.792
180,000	40	1.000
200,000	44	1.237
220,000	47	1.495
240,000	50	1.775
260,000	53	2.090
280,000	56	2.420
300,000	58	2.780

Table II

BASIC BEARING NO.	TRACK CAPACITY LBS.	BASIC BEARING NO.	TRACK CAPACITY LBS.
1/2-N	485	1 7/8	5,415
1/2	530	2	7,350
9/16	595	2 1/4	8,260
5/8-N	725	2 1/2	11,100
5/8	785	2 3/4	12,250
11/16	865	3	15,050
3/4	1,085	3 1/4	16,300
7/8	1,260	3 1/2	20,200
1	1,835	4	26,200
1 1/8	2,060	5	38,600
1 1/4	2,660	6	55,600
1 3/8	2,920	7	75,600
1 1/2	3,760	8	94,000
1 5/8	4,065	9	118,000
1 3/4	5,060	10	145,000

Cam Design

Most cam applications are similar in many respects to the track or support roller applications; however, usually bearing speeds are higher due to the multiplication of cam revolutions per minute by the ratio of the cam O.D. to the cam follower O.D. For cam applications, oil lubrication is preferred due to the tendency towards higher speeds noted above, and where such lubrication methods are not possible, frequent replacement of grease should be followed.

In the application of box or drum cams, it is possible to obtain differential rotation of the cam follower outer race as well as associated load reversals and unless proper cam hardness and materials are employed as well as ample lubrication, excessive cam or cam follower wear may result. In box cams of this nature, the cam rise and cam fall should be watched closely, since the load reversal encountered can cause shock loads in excess of the capacity of the stud or the bearing.

The above precaution would also apply to ordinary circular cams, and instantaneous loads due to rapid cam rise should be carefully calculated and kept below the ultimate strength of the follower and the stud.

In ordinary cam design it is possible to employ the most efficient materials for best resistance to fatigue and brinelling, and attainment of high track surface hardnesses associated with good wear resistance are quite feasible. The same general precautions with regard to tensile strength versus hardness, as listed under track design above, should be followed for cam design; and applications involving high marginal bearing or cam loading should be referred to the McGill Engineering Department for approval.

Lubrication

Cam followers are supplied with potential for 3 alternate means of lubrication; namely, through either end of the stud with an appropriate grease fitting or through the radial hole in the stem of the stud. The four smallest sizes, CF-1/2, 9/16, 5/8 and 11/16 are an exception to the above information, since they contain neither the radial oil hole in the stem nor the axial hole at the threaded end of the stud. Therefore, these bearings may only be lubricated from the flange end of the stud. It is also not necessary to plug the radial oil hole in the stem in most applications, since this hole is effectively sealed by the close fit of the stud in the housing support member. Oil hole plugs are supplied for closing off the axial hole or holes not being used for relubrication.

For grease relubrication of the cam follower series, the following drive fittings may be employed in the axial stud oil hole:

CF-1/2 to CF-11/16 incl.

1/8" drive fitting Alemite No. 3019.

CF-3/4 to CF-23/4 incl.

3/16" drive fitting Alemite No. 1633, 1728-B, 3005, or 3006, Lincoln No. 5033 or 5026, Balcrank No. B511MH-800208 or B633MH-817097.

CF-3 to CF-4 incl.

1/4" drive fitting Alemite No. 1743 or No. 1743-B, Lincoln No. 5029, Balcrank No. B743MH-817098 or B626MH-800227.

CF-5 to CF-10 incl.

1/4" N.P.T. fitting Alemite No. 1627B, Lincoln No. 5050, Balcrank No. B627MH-800229.

The relubrication of cam yoke roller bearings is straight forward and is accomplished by means of the radial oil hole "H" and annular lubrication groove found on the inner race of the bearing series. The mounting pin for this bearing series must be drilled axially and radially to properly line up with the groove and hole of the CYR bearing inner race to effect proper lubrication.

Bearings may be grease or oil lubricated, depending on a number of conditions, such as: type of sealing, load, amount and type of contamination, and amount and type of moisture present, temperature, and friction requirements.

For continuously rotating applications, it is necessary to either provide continuous oil lubrication or else frequent grease lubrication, depending upon the severity of service. Automatic lubrication devices are ideal for intermittent lubrication, since accurate metering of grease and consistent relubrication is maintained through the use of these devices. In applications involving paper dust and other similar abrasive contaminants, relubrication must be resorted to at more frequent intervals and the factory should be consulted for these critical applications.

Since in most cam followers two axial lubrication holes are provided, it is necessary to plug one or both of the holes, depending upon the type of relubrication means employed. For this purpose, oil hole plugs are provided in the bearing wrapping and may be press fitted in the reamed lubrication fitting hole. They are designed to withstand normal relubrication pressures. In sealed cam followers and cam yoke rollers, a small vent or relief is provided in each seal to enable relubrication of the bearing. To avoid loss of seal efficiency, this seal vent is kept as small as possible, and for this reason the rate of relubrication should be kept at lower levels to avoid seal displacement.

The cam follower and cam yoke roller bearings are factory lubricated with a medium temperature grease. Contact the McGill Engineering Department when application conditions require special lubricants.

Black oxide finish

All CAMROL® Bearings have a black oxide finish on all external surfaces. The black oxide finish will provide some corrosion resistance to the surfaces.

Mounting details - CF bearings

- (1) The cam follower should be drawn up tightly endwise so the bearing endplate is securely backed up by the machine member. However precaution should be taken, especially on the smaller sizes, that excessive torque is not applied when tightening the nut. Otherwise, undue stress may be set up in the stud.
- (2) A screw-driver slot is provided at the flanged end of the stud for the purpose of preventing the stud from turning when the nut is tightened. The bottom of the screw-driver slot is rounded and in some cases it may be necessary to use a special screw-driver having a rounded edge to hold the stud securely.
- (3) An optional hexagonal hole is provided in the stud face on selected sizes for use with applications involving bearings mounted in blind holes or with self-locking nuts requiring greater than average thread torque. In this modification, the ability to relubricate through the flange end of the stud is eliminated on sizes smaller than 3 inch outer diameter.
- (4) When driving the stud into the machine member, any pressure should be directed against the solid end of the stud, not against the flanged portion. This operation should be performed on an arbor press whenever possible.
- (5) The cam follower stud diameter "SD" should have a tight fit in the housing bore. Follow, whenever possible, the recommended housing bore diameters given in the dimensional tables.

ENGINEERING SECTION

Mounting details - CYR bearings

(1) For heavily loaded applications, the ideal mounting arrangement is to have a drive or press fit in the bore of the inner ring, the bearing clamped endwise over the endplates, and the shaft hardened.

If the load is moderate, a push fit may be substituted. If the load is light, a push fit may be used and the shaft not hardened.

(2) If it is not desired to clamp the bearing endwise, and the load is heavy, a press fit should be used and the shaft hardened.

If the load is light, the shaft does not have to be surface hardened.

Furthermore, if the CYR cannot be clamped endwise it is essential to have a close fit axially in the yoke, in which the bearing is mounted — this to prevent the bearing endplates displacing axially.

(3) The minimum internal diametral looseness (total) of standard CYRs is .0006 greater than that of the CF cam followers to allow for possible interference fits in the bore of the inner ring.

(4) For recommended CYR shaft fits and tolerances, refer to the dimensional tables.

Bearing options — LUBRI-DISC® seal

LUBRI-DISC® seals improve bearing life and performance by providing protection against contamination and loss of lubricant, and by reducing internal bearing friction. Lip-type, moly-filled nylon seals provide a close running fit in the outer ring seal undercut and interference fit on the endplate and flange O.D. Moly-filled nylon rings reduce friction between outer ring counter-bore faces and inside

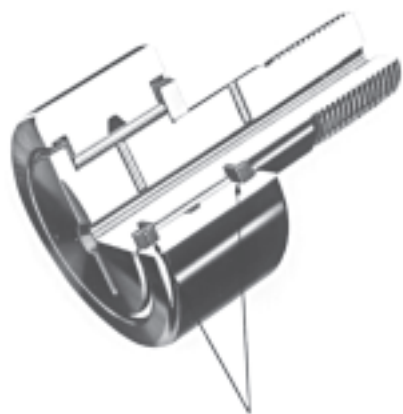

LUBRI-DISC® seals

faces of endplates and flanges. Resulting lower operating temperatures substantially reduce relubrication requirements and permit higher operating speeds. LUBRI-DISC® seals have a continuous operating temperature of -65°F to +250°F. CAMROL® bearings with LUBRI-DISC® seals have an annular groove in the center of the outer

raceway that acts as a lubricant reservoir. LUBRI-DISC® seals are vented to prevent seal blowout during relubrication.

Crowned O.D.

CAMROL® CF, CFH and CYR series bearings are available with crowned O.D. Crowning of the outer race or roller surface reduces the possibility of edge loading of rollers in applications where misalignment can cause this problem.

O.D. crown radius*

McGILL® BEARING NO.	CROWN RADIUS (INCHES) (R)	McGILL® BEARING NO.	CROWN RADIUS (INCHES) (R)
CCF-1/2-N-S	6	CCF-1 7/8-S	20
CCF-1/2-S	7	CCF-2-S	24
CCF-9/16-S	7	CCF-2 1/4-S	24
CCF-5/8-N-S	7	CCF-2 1/2-S	30
CCF-5/8-S	8	CCF-2 3/4-S	30
CCF-11/16-S	8	CCF-3-S	30
CCF-3/4-S	10	CCF-3 1/4-S	30
CCF-7/8-S	10	CCF-3 1/2-S	30
CCF-1-S	12	CCF-4-S	30
CCF-1 1/8-S	12	CCF-5-S	48
CCF-1 1/4-S	14	CCF-6-S	56
CCF-1 3/8-S	14	CCF-7-S	60
CCF-1 1/2-S	20	CCF-8-S	40
CCF-1 5/8-S	20	CCF-9-S	40
CCF-1 3/4-S	20	CCF-10-S	40

*Same crown radius applies to CCYR-S and CCFH-S series.

Eccentric stud

The eccentric stud feature provides a means of easy radial adjustment for precise positioning of cam followers, track, guide and support rollers.

In-line combinations of eccentric stud CAMROL® bearings can be aligned without the need for close tolerances of mounting holes and members. Problems involving control of clearances, pre-loading and compensation for wear can be avoided or solved by the easy adjustment of new bearings.



In most applications, a lock nut is sufficient to hold the bearing at the desired position. In applications where a more positive means of holding a given position is required, this can be accomplished by drilling and dowelling through the housing into the bushing and the stud. The hex socket allows positive torque for adjustment and locking.

Eccentric stud

(For other dimensions refer to tabulated chart)

BASIC BEARING NO. BEARING SIZE	BUSHING DIA. ±.001	RECOMMENDED HOUSING BORE DIA. ±.001
1/2	0.250	0.253
9/16	0.250	0.253
5/8	0.375	0.378
11/16	0.375	0.378
3/4	0.500	0.503
7/8	0.500	0.503
1	0.625	0.628
1 1/8	0.625	0.628
1 1/4	0.687	0.690
1 3/8	0.687	0.690
1 1/2	0.875	0.878
1 5/8	0.875	0.878
1 3/4	1.000	1.003
1 7/8	1.000	1.003
2	1.187	1.190
2 1/4	1.187	1.190
2 1/2	1.375	1.378
2 3/4	1.375	1.378
3	1.750	1.753
3 1/4	1.750	1.753
3 1/2	1.812	1.815
4	2.000	2.003

Hex hole



Standard and heavy stud CAMROL® bearings are available with a hexagonal hole in the face of the stud in place of the screwdriver slot. This feature is advantageous for mounting bearings in blind holes or with self-locking nuts requiring greater-than-average thread torque. In this modification, relubrication through the flange end of the stud is not possible on sizes smaller than 3 inch outer diameter.

Hex wrench sizes

BASIC BEARING NO.	HEX WRENCH SIZE	BASIC BEARING NO.	HEX WRENCH SIZE
1/2	1/8	1 7/8	5/16
9/16	1/8	2	7/16
5/8	1/8	2 1/4	7/16
11/16	1/8	2 1/2	1/2
3/4	3/16	2 3/4	1/2
7/8	3/16	3	3/4
1	1/4	3 1/4	3/4
1 1/8	1/4	3 1/2	3/4
1 1/4	1/4	4	3/4
1 3/8	1/4	5	7/8
1 1/2	5/16	6	1
1 5/8	5/16	7, 8, 9, 10	1 1/4
1 3/4	5/16		

CAMROL® Bearings

Non-metallic bushings in place of rollers

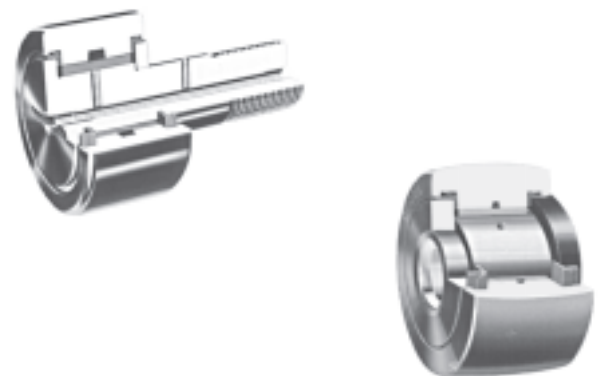

Replacing rollers, a non-metallic bushing provides load support and a sliding motion that eliminates or reduces need for bearing lubrication. The CAMROL® bearing BCF-S series with integral studs and the BCYR-S series (yoke roller type) without studs are recommended for use where relubrication is not convenient or where the possibility of grease contamination of the product being processed is not acceptable.

The CAMROL® bushing type cam follower is standard in roller sizes from 1/2" to 4" and double sealed to reduce contamination. LUBRI-DISC rings reduce internal friction for longer trouble free life. Optional features, also available, include crowned O.D., hex hole for hex wrench mounting, and eccentric stud.

Maximum allowable continuous operating temperature is up to 200°F. Bushing CAMROL® bearings are intended to be used in the self-lubricated mode. However, continuous feed oil lubrication can be used to provide reduced wear rates. Grease lubrication should not be used.

The bushing type CAMROL® is not recommended for food machinery applications where contact with food products may occur.

CF & CF-S SERIES

CF Series Standard

Sealed and unsealed bearings showing optional features available in combination as shown in the following table (see following page).

Illustrated are each of 4 possible options available on standard cam follower bearings. These may be combined to best serve any application and combinations regularly stocked are shown in the following tables. Others would be special and should be discussed with the McGill Engineering Department.

Maximum static load should not exceed the rating given in charts, or excessive permanent stud deflection will occur. Maximum dynamic load should not exceed 50% of Basic Dynamic Rating. If radial load and/or Root Mean Load exceed 50% of Basic Dynamic Rating, life calculations must be reviewed by McGill. If dynamic loads exceed 25% of Basic Dynamic Rating, consideration should be given to use of CFH or CYR series CAMROL® bearings. Applications involving reversing radial loads should be reviewed by the McGill Engineering Department.

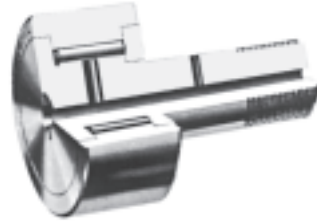

CF & CF-S Series

Cam followers with and without LUBRI-DISC® seals

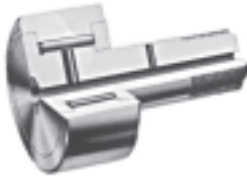

Unsealed

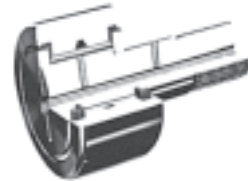

With LUBRI-DISC seals

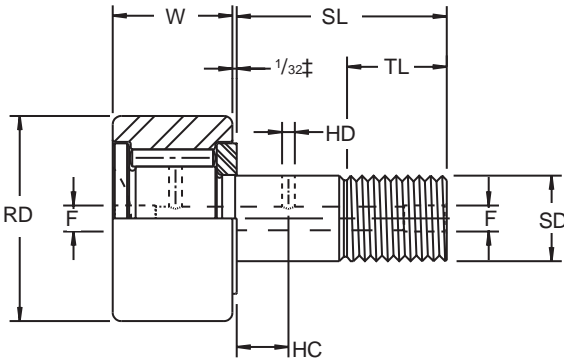

±1/16" on CF-5, CF-6, CF-7

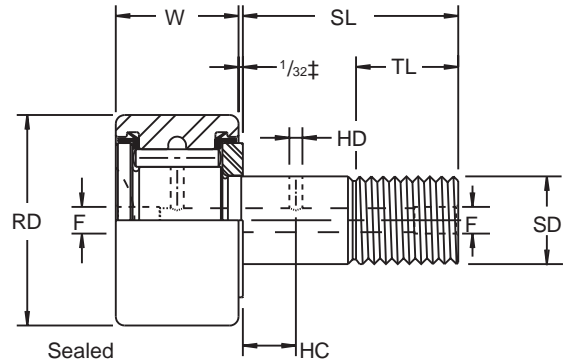

±1/16" on CF-5-S, CF-6-S, CF-7-S

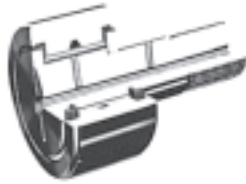

With LUBRI-DISC® seals
add letter "S"
Ex. CF-1³/₄-S



Crowned O.D.
add letter "C"
Ex. CCF-1³/₄-S



Hex Hole
add letter "B"
Ex. CF-1³/₄-SB



Eccentric Stud
add letter "E"
Ex. CFE-1³/₄-SB

UNSEALED BRG. NO.	SEALED BRG. NO.	ROLLER DIA. (RD) +.000 -0.001	ROLLER WIDTH (W) +.000 -0.005	STUD DIA. (SD) +.001 -0.001	STUD L'GTH. (SL)	MIN. THR'D L'GTH. (TL)	FINE THR'DS.	OIL HOLE		LUB. FITTING SIZE (F)*	MIN. BOSS DIA.	HOUSING BORE DIA. +.0002 -0.003	***RECOM. CLAMPING TORQUE LBS.-IN.	MAX. STATIC CAPACITY LBS.	BASIC DYN. RATING LBS.
								HOLE CENTER (HC)	HOLE DIA. (HD)						
CF-1/2-N	CF-1/2-N-S	.500	.344	.190	1/2	1/4	10-32	-	-	1/8*	19/64	.1903	15	720	620
CF-1/2	CF-1/2-S	.500	.375	.190	5/8	1/4	10-32	-	-	1/8*	19/64	.1903	15	790	680
CF-9/16	CF-9/16-S	.5625	.375	.190	5/8	1/4	10-32	-	-	1/8*	19/64	.1903	15	790	680
CF-5/8-N	CF-5/8-N-S	.625	.406	.250	5/8	5/16	1/4-28	-	-	1/8*	23/64	.2503	35	1085	930
CF-5/8	CF-5/8-S	.625	.4375	.250	3/4	5/16	1/4-28	-	-	1/8*	23/64	.2503	35	1215	955
CF-11/16	CF-11/16-S	.6875	.4375	.250	3/4	5/16	1/4-28	-	-	1/8*	23/64	.2503	35	1215	955
CF-3/4	CF-3/4-S	.750	.500	.375	7/8	3/8	3/8-24	1/4	3/32	3/16	1/2	.3753	95	2065	1660
CF-7/8	CF-7/8-S	.875	.500	.375	7/8	3/8	3/8-24	1/4	3/32	3/16	1/2	.3753	95	2065	1660
CF-1	CF-1-S	1.000	.625	.4375	1	1/2	7/16-20	1/4	3/32	3/16	41/64	.4378	250	3060	2225
CF-1 1/8	CF-1 1/8-S	1.125	.625	.4375	1	1/2	7/16-20	1/4	3/32	3/16	41/64	.4378	250	3060	2225
CF-1 1/4	CF-1 1/4-S	1.250	.750	.500	1 1/4	5/8	1/2-20	5/16	3/32	3/16	49/64	.5003	350	4250	3930
CF-1 3/8	CF-1 3/8-S	1.375	.750	.500	1 1/4	5/8	1/2-20	5/16	3/32	3/16	49/64	.5003	350	4250	3930
CF-1 1/2	CF-1 1/2-S	1.500	.875	.625	1 1/2	3/4	5/8-18	3/8	3/32	3/16	57/64	.6253	650	5640	4840
CF-1 5/8	CF-1 5/8-S	1.625	.875	.625	1 1/2	3/4	5/8-18	3/8	3/32	3/16	57/64	.6253	650	5640	4840
CF-1 3/4	CF-1 3/4-S	1.750	1.000	.750	1 3/4	7/8	3/4-16	7/16	3/32	3/16	1 3/64	.7503	1250	7920	6385
CF-1 7/8	CF-1 7/8-S	1.875	1.000	.750	1 3/4	7/8	3/4-16	7/16	3/32	3/16	1 3/64	.7503	1250	7920	6385
CF-2	CF-2-S	2.000	1.250	.875	2	1	7/8-14	1/2	1/8	3/16	1 13/64	.8753	1500	10570	8090
CF-2 1/4	CF-2 1/4-S	2.250	1.250	.875	2	1	7/8-14	1/2	1/8	3/16	1 13/64	.8753	1500	10570	8090
CF-2 1/2	CF-2 1/2-S	2.500	1.500	1.000	2 1/4	1 1/8	1-14	9/16	1/8	3/16	1 5/16	1.0003	2250	16450	11720
CF-2 3/4	CF-2 3/4-S	2.750	1.500	1.000	2 1/4	1 1/8	1-14	9/16	1/8	3/16	1 5/16	1.0003	2250	16450	11720
CF-3	CF-3-S	3.000	1.750	1.250	2 1/2	1 1/4	1 1/4-12	5/8	1/8	1/4	1 3/4	1.2503	3450	24910	15720
CF-3 1/4	CF-3 1/4-S	3.250	1.750	1.250	2 1/2	1 1/4	1 1/4-12	5/8	1/8	1/4	1 3/4	1.2503	3450	24910	15720
CF-3 1/2	CF-3 1/2-S	3.500	2.000	1.375	2 3/4	1 3/8	1 3/8-12	11/16	1/8	1/4	1 59/64	1.3753	4200	31625	22800
CF-4	CF-4-S	4.000	2.250	1.500	3 1/2	1 1/2	1 1/2-12	3/4	1/8	1/4	2 9/32	1.5003	5000	44770	29985
	CF-5-S	5.000	2.750	2.000	5 1/16	2 9/16	2-12	7/8	3/16	1/4 N.P.T.	2 7/8	2.0003	5000	67950	46575
	CF-6-S	6.000	3.250	2.500	6	3	2 1/2-12	1	3/16	1/4 N.P.T.	3 3/8	2.5003	5000	80450	60000
	†CF-7-S	7.000	3.750	3.000	7 11/16	4 1/8	3-12	1 1/4	3/16	1/4 N.P.T.	3 7/8	3.0003	5000	106930	75380
	†CF-8-S ♦	8.000	4.250**	3.250	8 1/2	4 1/4	3 1/4-4*	-	-	1/4 N.P.T.*	4 3/4	3.2503	5000	144100	92200
	†CF-9-S ♦	9.000	4.750**	3.750	9 1/2	4 3/4	3 1/2-4*	-	-	1/4 N.P.T.*	5 7/16	3.7503	5000	183430	113260
	†CF-10-S♦	10.000	5.250**	4.250	10	4 3/4	3 1/2-4*	-	-	1/4 N.P.T.*	5 59/64	4.2503	5000	215565	131545

† Not available from stock. Consult McGill Customer Service for availability.
 ♦ Standard tolerances do not apply. Consult McGill Customer Service.
 * Oil hole (F) drilled from the flange end of the stud to the radial oil hole only.
 ** Flange extends 3/4" beyond face of outer race, and endplate extends 1/8" beyond face of outer race.
 *** Clamping torque is based on dry threads. If threads are lubricated, use half of values shown.
 • Coarse threads.

CF-B & CF-SB SERIES

**Cam followers with hex holes,
with and without LUBRI-DISC® seals**



See page 15 for hex wrench sizes.

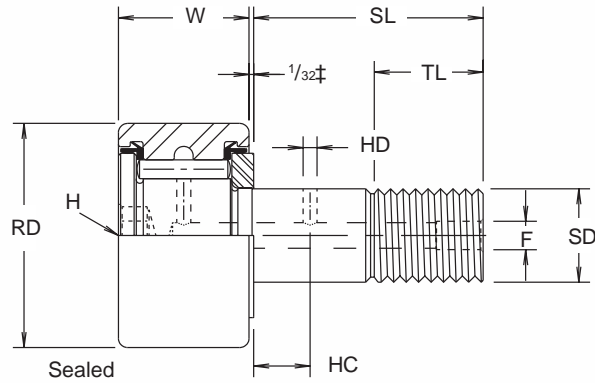

UNSEALED BRG. NO.	SEALED BRG. NO.	ROLLER DIA. (RD) +.000 -0.001	ROLLER WIDTH (W) +.000 -0.005	STUD DIA. (SD) +.001 -0.000	STUD L'GTH. (SL)	MIN. THR'D L'GTH. (TL)	FINE THR'DS.	OIL HOLE		LUB. FITTING SIZE (F)	MIN. BOSS DIA.	HOUSING BORE DIA. +.0002 -0.0003	***RECOM. CLAMPING TORQUE LBS.-IN.	MAX. STATIC CAPACITY LBS.	BASIC DYN. RATING LBS.
								HOLE CENTER (HC)	HOLE DIA. (HD)						
CF-1/2-N-B	CF-1/2-N-SB	.500	.344	.190	1/2	1/4	10-32	-	-	-	19/64	.1903	15	720	620
CF-1/2-B	CF-1/2-SB	.500	.375	.190	5/8	1/4	10-32	-	-	-	19/64	.1903	15	790	680
CF-9/16-B	CF-9/16-SB	.5625	.375	.190	5/8	1/4	10-32	-	-	-	19/64	.1903	15	790	680
CF-5/8-N-B	CF-5/8-N-SB	.625	.406	.250	5/8	5/16	1/4-28	-	-	-	23/64	.2503	35	1085	930
CF-5/8-B	CF-5/8-SB	.625	.4375	.250	3/4	5/16	1/4-28	-	-	-	23/64	.2503	35	1215	955
CF-11/16-B	CF-11/16-SB	.6875	.4375	.250	3/4	5/16	1/4-28	-	-	-	23/64	.2503	35	1215	955
CF-3/4-B	CF-3/4-SB	.750	.500	.375	7/8	3/8	3/8-24	1/4	3/32	3/16	1/2	.3753	95	2065	1660
CF-7/8-B	CF-7/8-SB	.875	.500	.375	7/8	3/8	3/8-24	1/4	3/32	3/16	1/2	.3753	95	2065	1660
CF-1-B	CF-1-SB	1.000	.625	.4375	1	1/2	7/16-20	1/4	3/32	3/16	41/64	.4378	250	3060	2225
CF-1 1/8-B	CF-1 1/8-SB	1.125	.625	.4375	1	1/2	7/16-20	1/4	3/32	3/16	41/64	.4378	250	3060	2225
CF-1 1/4-B	CF-1 1/4-SB	1.250	.750	.500	1 1/4	5/8	1/2-20	5/16	3/32	3/16	49/64	.5003	350	4250	3930
CF-1 3/8-B	CF-1 3/8-SB	1.375	.750	.500	1 1/4	5/8	1/2-20	5/16	3/32	3/16	49/64	.5003	350	4250	3930
CF-1 1/2-B	CF-1 1/2-SB	1.500	.875	.625	1 1/2	3/4	5/8-18	3/8	3/32	3/16	57/64	.6253	650	5640	4840
CF-1 5/8-B	CF-1 5/8-SB	1.625	.875	.625	1 1/2	3/4	5/8-18	3/8	3/32	3/16	57/64	.6253	650	5640	4840
CF-1 3/4-B	CF-1 3/4-SB	1.750	1.000	.750	1 3/4	7/8	3/4-16	7/16	3/32	3/16	1 3/64	.7503	1250	7920	6385
CF-1 7/8-B	CF-1 7/8-SB	1.875	1.000	.750	1 3/4	7/8	3/4-16	7/16	3/32	3/16	1 3/64	.7503	1250	7920	6385
CF-2-B	CF-2-SB	2.000	1.250	.875	2	1	7/8-14	1/2	1/8	3/16	1 13/64	.8753	1500	10570	8090
CF-2 1/4-B	CF-2 1/4-SB	2.250	1.250	.875	2	1	7/8-14	1/2	1/8	3/16	1 13/64	.8753	1500	10570	8090
CF-2 1/2-B	CF-2 1/2-SB	2.500	1.500	1.000	2 1/4	1 1/8	1-14	9/16	1/8	3/16	1 5/16	1.0003	2250	16450	11720
CF-2 3/4-B	CF-2 3/4-SB	2.750	1.500	1.000	2 1/4	1 1/8	1-14	9/16	1/8	3/16	1 5/16	1.0003	2250	16450	11720
CF-3-B	CF-3-SB	3.000	1.750	1.250	2 1/2	1 1/4	1 1/4-12	5/8	1/8	① 1/4	1 3/4	1.2503	3450	24910	15720
CF-3 1/4-B	CF-3 1/4-SB	3.250	1.750	1.250	2 1/2	1 1/4	1 1/4-12	5/8	1/8	① 1/4	1 3/4	1.2503	3450	24910	15720
CF-3 1/2-B	CF-3 1/2-SB	3.500	2.000	1.375	2 3/4	1 3/8	1 3/8-12	11/16	1/8	① 1/4	1 59/64	1.3753	4200	31625	22800
CF-4-B	CF-4-SB	4.000	2.250	1.500	3 1/2	1 1/2	1 1/2-12	3/4	1/8	① 1/4	2 9/32	1.5003	5000	44770	29985

*** Clamping torque is based on dry threads. If threads are lubricated, use half of values shown.
 ① Lubrication hole (F) at bottom of hex hole and 1/4 inch straight drive fitting with ball check supplied but not installed.
 Hex hole standard on sizes above CF-4-SB.
 See page 17 for bearing dimensions.

**Cam followers with eccentric studs,
with and without LUBRI-DISC® seals**

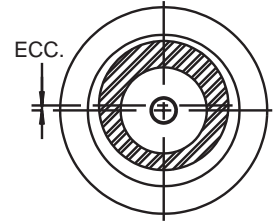
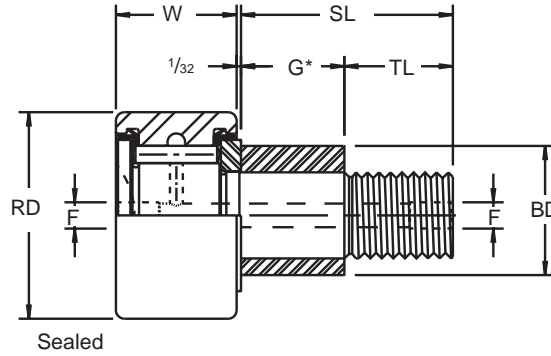

CAMROL® Bearings

UNSEALED BRG. NO.	SEALED BRG. NO.	ROLLER DIA. (RD) +.000 -.001	ROLLER WIDTH (W) +.000 -.005	BUSH. L'GTH (G*) +.000 -.010	BUSH. DIA. (BD) ±.001	STUD L'GTH. (SL)	MIN. THR'D L'GTH. (TL)	FINE THR'D S.	ECC.	LUB. FITTING SIZE (F)**	***RECOM. CLAMPING TORQUE LBS.-IN.	MAX. STATIC CAPACITY LBS.	BASIC DYN. RATING LBS.
CFE-1/2	CFE-1/2-S	.500	.375	.375	.250	5/8	1/4	10-32	.010	1/8**	15	790	680
CFE-9/16	CFE-9/16-S	.5625	.375	.375	.250	5/8	1/4	10-32	.010	1/8**	15	790	680
CFE-5/8	CFE-5/8-S	.625	.4375	.437	.375	3/4	5/16	1/4-28	.015	1/8**	35	1215	955
CFE-11/16	CFE-11/16-S	.6875	.4375	.437	.375	3/4	5/16	1/4-28	.015	1/8**	35	1215	955
CFE-3/4	CFE-3/4-S	.750	.500	.500	.500	7/8	3/8	3/8-24	.015	3/16	95	2065	1660
CFE-7/8	CFE-7/8-S	.875	.500	.500	.500	7/8	3/8	3/8-24	.015	3/16	95	2065	1660
CFE-1	CFE-1-S	1.000	.625	.500	.625	1	1/2	7/16-20	.030	3/16	250	3060	2225
CFE-1 1/8	CFE-1 1/8-S	1.125	.625	.500	.625	1	1/2	7/16-20	.030	3/16	250	3060	2225
CFE-1 1/4	CFE-1 1/4-S	1.250	.750	.625	.687	1 1/4	5/8	1/2-20	.030	3/16	350	4250	3930
CFE-1 3/8	CFE-1 3/8-S	1.375	.750	.625	.687	1 1/4	5/8	1/2-20	.030	3/16	350	4250	3930
CFE-1 1/2	CFE-1 1/2-S	1.500	.875	.750	.875	1 1/2	3/4	5/8-18	.030	3/16	650	5640	4840
CFE-1 5/8	CFE-1 5/8-S	1.625	.875	.750	.875	1 1/2	3/4	5/8-18	.030	3/16	650	5640	4840
CFE-1 3/4	CFE-1 3/4-S	1.750	1.000	.875	1.000	1 3/4	7/8	3/4-16	.030	3/16	1250	7920	6385
CFE-1 7/8	CFE-1 7/8-S	1.875	1.000	.875	1.000	1 3/4	7/8	3/4-16	.030	3/16	1250	7920	6385
CFE-2	CFE-2-S	2.000	1.250	1.000	1.187	2	1	7/8-14	.030	3/16	1500	10570	8090
CFE-2 1/4	CFE-2 1/4-S	2.250	1.250	1.000	1.187	2	1	7/8-14	.030	3/16	1500	10570	8090
CFE-2 1/2	CFE-2 1/2-S	2.500	1.500	1.125	1.375	2 1/4	1 1/8	1-14	.030	3/16	2250	16450	11720
CFE-2 3/4	CFE-2 3/4-S	2.750	1.500	1.125	1.375	2 1/4	1 1/8	1-14	.030	3/16	2250	16450	11720
CFE-3	CFE-3-S	3.000	1.750	1.250	1.750	2 1/2	1 1/4	1 1/4-12	.060	1/4	3450	24910	15720
CFE-3 1/4	CFE-3 1/4-S	3.250	1.750	1.250	1.750	2 1/2	1 1/4	1 1/4-12	.060	1/4	3450	24910	15720
CFE-3 1/2	CFE-3 1/2-S	3.500	2.000	1.375	1.812	2 3/4	1 3/8	1 3/8-12	.060	1/4	4200	31625	22800
CFE-4	CFE-4-S	4.000	2.250	2.000	2.000	3 1/2	1 1/2	1 1/2-12	.060	1/4	5000	44770	29985

* For positive clamping, use housing thickness equal to G dimension +.010. Bushing press fit on stem and unhardened to permit dowel or set screw for permanent locking.

See page 15 for recommended housing bore diameter.

** Oil hole (F) drilled from Flange end of stud to the radial oil hole only.

*** Clamping torque is based on dry threads. If threads are lubricated, use half of values shown.

CFE-B & CFE-SB SERIES

Cam followers with eccentric studs and hex holes, with and without LUBRI-DISC® seals



See page 15 for hex wrench sizes.

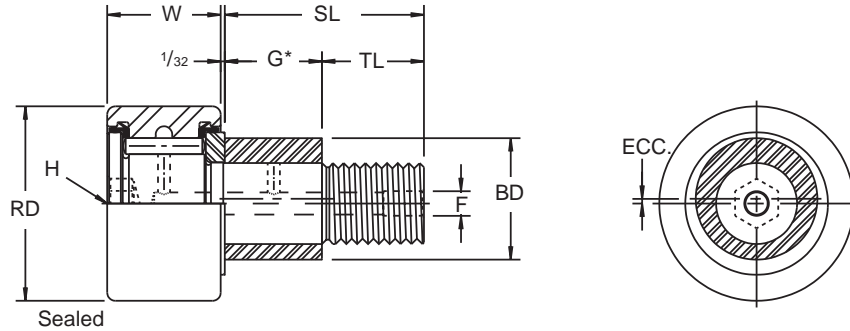

UNSEALED BRG. NO.	SEALED BRG. NO.	ROLLER DIA. (RD) +.000 -.001	ROLLER WIDTH (W) +.000 -.005	BUSH. L'GTH (G*) +.000 -.010	BUSH. DIA. (BD) ±.001	STUD L'GTH. (SL)	MIN. THR'D L'GTH. (TL)	FINE THR'DS.	ECC.	LUB. FITTING SIZE (F)	***RECOM. CLAMPING TORQUE LBS.-IN.	MAX. STATIC CAPACITY LBS.	BASIC DYN. RATING LBS.
CFE-1/2-N-B	CFE-1/2-N-SB	.500	.344	.250	.250	1/2	1/4	10-32	.010	-	15	720	620
CFE-1/2-B	CFE-1/2-SB	.500	.375	.375	.250	5/8	1/4	10-32	.010	-	15	790	680
CFE-9/16-B	CFE-9/16-SB	.5625	.375	.375	.250	5/8	1/4	10-32	.010	-	15	790	680
CFE-5/8-B	CFE-5/8-SB	.625	.4375	.437	.375	3/4	5/16	1/4-28	.015	-	35	1215	955
CFE-11/16-B	CFE-11/16-SB	.6875	.4375	.437	.375	3/4	5/16	1/4-28	.015	-	35	1215	955
CFE-3/4-B	CFE-3/4-SB	.750	.500	.500	.500	7/8	3/8	3/8-24	.015	3/16	95	2065	1660
CFE-7/8-B	CFE-7/8-SB	.875	.500	.500	.500	7/8	3/8	3/8-24	.015	3/16	95	2065	1660
CFE-1-B	CFE-1-SB	1.000	.625	.500	.625	1	1/2	7/16-20	.030	3/16	250	3060	2225
CFE-1 1/8-B	CFE-1 1/8-SB	1.125	.625	.500	.625	1	1/2	7/16-20	.030	3/16	250	3060	2225
CFE-1 1/4-B	CFE-1 1/4-SB	1.250	.750	.625	.687	1 1/4	5/8	1/2-20	.030	3/16	350	4250	3930
CFE-1 3/8-B	CFE-1 3/8-SB	1.375	.750	.625	.687	1 1/4	5/8	1/2-20	.030	3/16	350	4250	3930
CFE-1 1/2-B	CFE-1 1/2-SB	1.500	.875	.750	.875	1 1/2	3/4	5/8-18	.030	3/16	650	5640	4840
CFE-1 5/8-B	CFE-1 5/8-SB	1.625	.875	.750	.875	1 1/2	3/4	5/8-18	.030	3/16	650	5640	4840
CFE-1 3/4-B	CFE-1 3/4-SB	1.750	1.000	.875	1.000	1 3/4	7/8	3/4-16	.030	3/16	1250	7920	6385
CFE-1 7/8-B	CFE-1 7/8-SB	1.875	1.000	.875	1.000	1 3/4	7/8	3/4-16	.030	3/16	1250	7920	6385
CFE-2-B	CFE-2-SB	2.000	1.250	1.000	1.187	2	1	7/8-14	.030	3/16	1500	10570	8090
CFE-2 1/4-B	CFE-2 1/4-SB	2.250	1.250	1.000	1.187	2	1	7/8-14	.030	3/16	1500	10570	8090
CFE-2 1/2-B	CFE-2 1/2-SB	2.500	1.500	1.125	1.375	2 1/4	1 1/8	1-14	.030	3/16	2250	16450	11720
CFE-2 3/4-B	CFE-2 3/4-SB	2.750	1.500	1.125	1.375	2 1/4	1 1/8	1-14	.030	3/16	2250	16450	11720
CFE-3-B	CFE-3-SB	3.000	1.750	1.250	1.750	2 1/2	1 1/4	1 1/4-12	.060	① 1/4	3450	24910	15720
CFE-3 1/4-B	CFE-3 1/4-SB	3.250	1.750	1.250	1.750	2 1/2	1 1/4	1 1/4-12	.060	① 1/4	3450	24910	15720
CFE-3 1/2-B	CFE-3 1/2-SB	3.500	2.000	1.375	1.812	2 3/4	1 3/8	1 3/8-12	.060	① 1/4	4200	31625	22800
CFE-4-B	CFE-4-SB	4.000	2.250	2.000	2.000	3 1/2	1 1/2	1 1/2-12	.060	① 1/4	5000	44770	29985

* For positive clamping, use housing thickness equal to G dimension +.010. Bushing press fit on stem and unhardened to permit dowel or set screw for permanent locking. See page 15 for recommended housing bore diameter.
 *** Clamping torque is based on dry threads. If threads are lubricated, use half of values shown.
 ① Lubrication hole (F) at bottom of hex hole and 1/4 inch straight drive fitting with ball check supplied but not installed.

Cam followers with crowned O.D.s and LUBRI-DISC® seals



See page 14 for crown details.

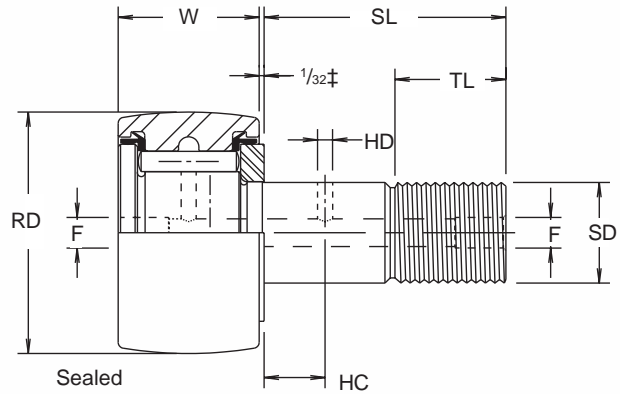

±1/16" on CCF-5-S, CCF-6-S, CCF-7-S

BRG. NO.	ROLLER DIA. (RD) +.000 -.001	ROLLER WIDTH (W) +.000 -.005	STUD DIA. (SD) +.001 -.000	STUD L'GTH. (SL)	MIN. THR'D L'GTH. (TL)	FINE THR'D'S.	OIL HOLE		LUB. FITTING SIZE (F)*	MIN. BOSS DIA.	HOUSING BORE DIA. +.0002 -.0003	***RECOM. CLAMPING TORQUE LBS.-IN.	MAX. STATIC CAPACITY LBS.	BASIC DYN. RATING LBS.
							HOLE CENTER (HC)	HOLE DIA. (HD)						
CCF-1/2-N-S	.500	.344	.190	1/2	1/4	10-32	-	-	1/8*	19/64	.1903	15	720	620
CCF-1/2-S	.500	.375	.190	5/8	1/4	10-32	-	-	1/8*	19/64	.1903	15	790	680
CCF-9/16-S	.5625	.375	.190	5/8	1/4	10-32	-	-	1/8*	19/64	.1903	15	790	680
CCF-5/8-N-S	.625	.406	.250	5/8	5/16	1/4-28	-	-	1/8*	23/64	.2503	35	1085	930
CCF-5/8-S	.625	.4375	.250	3/4	5/16	1/4-28	-	-	1/8*	23/64	.2503	35	1215	955
CCF-11/16-S	.6875	.4375	.250	3/4	5/16	1/4-28	-	-	1/8*	23/64	.2503	35	1215	955
CCF-3/4-S	.750	.500	.375	7/8	3/8	3/8-24	1/4	3/32	3/16	1/2	.3753	95	2065	1660
CCF-7/8-S	.875	.500	.375	7/8	3/8	3/8-24	1/4	3/32	3/16	1/2	.3753	95	2065	1660
CCF-1-S	1.000	.625	.4375	1	1/2	7/16-20	1/4	3/32	3/16	41/64	.4378	250	3060	2225
CCF-1 1/8-S	1.125	.625	.4375	1	1/2	7/16-20	1/4	3/32	3/16	41/64	.4378	250	3060	2225
CCF-1 1/4-S	1.250	.750	.500	1 1/4	5/8	1/2-20	5/16	3/32	3/16	49/64	.5003	350	4250	3930
CCF-1 3/8-S	1.375	.750	.500	1 1/4	5/8	1/2-20	5/16	3/32	3/16	49/64	.5003	350	4250	3930
CCF-1 1/2-S	1.500	.875	.625	1 1/2	3/4	5/8-18	3/8	3/32	3/16	57/64	.6253	650	5640	4840
CCF-1 5/8-S	1.625	.875	.625	1 1/2	3/4	5/8-18	3/8	3/32	3/16	57/64	.6253	650	5640	4840
CCF-1 3/4-S	1.750	1.000	.750	1 3/4	7/8	3/4-16	7/16	3/32	3/16	1 3/64	.7503	1250	7920	6385
CCF-1 7/8-S	1.875	1.000	.750	1 3/4	7/8	3/4-16	7/16	3/32	3/16	1 3/64	.7503	1250	7920	6385
CCF-2-S	2.000	1.250	.875	2	1	7/8-14	1/2	1/8	3/16	1 13/64	.8753	1500	10570	8090
CCF-2 1/4-S	2.250	1.250	.875	2	1	7/8-14	1/2	1/8	3/16	1 13/64	.8753	1500	10570	8090
CCF-2 1/2-S	2.500	1.500	1.000	2 1/4	1 1/8	1-14	9/16	1/8	3/16	1 5/16	1.0003	2250	16450	11720
CCF-2 3/4-S	2.750	1.500	1.000	2 1/4	1 1/8	1-14	9/16	1/8	3/16	1 5/16	1.0003	2250	16450	11720
CCF-3-S	3.000	1.750	1.250	2 1/2	1 1/4	1 1/4-12	5/8	1/8	1/4	1 3/4	1.2503	3450	24910	15720
CCF-3 1/4-S	3.250	1.750	1.250	2 1/2	1 1/4	1 1/4-12	5/8	1/8	1/4	1 3/4	1.2503	3450	24910	15720
CCF-3 1/2-S	3.500	2.000	1.375	2 3/4	1 3/8	1 3/8-12	11/16	1/8	1/4	1 59/64	1.3753	4200	31625	22800
CCF-4-S	4.000	2.250	1.500	3 1/2	1 1/2	1 1/2-12	3/4	1/8	1/4	2 9/32	1.5003	5000	44770	29985
†CCF-5-S	5.000	2.750	2.000	5 1/16	2 9/16	2-12	7/8	3/16	1/4 N.P.T.	2 7/8	2.0003	5000	67950	46575
†CCF-6-S	6.000	3.250	2.500	6	3	2 1/2-12	1	3/16	1/4 N.P.T.	3 3/8	2.5003	5000	80450	60000
†CCF-7-S	7.000	3.750	3.000	7 11/16	4 1/8	3-12	1 1/4	3/16	1/4 N.P.T.	3 7/8	3.0003	5000	106930	75380
†CCF-8-S ♦	8.000	4.250**	3.250	8 1/2	4 1/4	3 1/4-4	-	-	1/4 N.P.T.*	4 3/4	3.2503	5000	144100	92200
†CCF-9-S ♦	9.000	4.750**	3.750	9 1/2	4 3/4	3 1/2-4	-	-	1/4 N.P.T.*	5 7/16	3.7503	5000	183430	113260
†CCF-10-S ♦	10.000	5.250**	4.250	10	4 3/4	3 1/2-4	-	-	1/4 N.P.T.*	5 59/64	4.2503	5000	215565	131545

† Not available from stock. Consult McGill Customer Service for availability.
 ♦ Standard tolerances do not apply. Consult McGill Customer Service.
 * Oil hole (F) drilled from the flange end of the stud to the radial oil hole only.
 ** Flange extends 3/4" beyond face of outer race, and endplate extends 1/8" beyond face of outer race.
 *** Clamping torque is based on dry threads. If threads are lubricated, use half of values shown.
 • Coarse threads.

CCF-SB SERIES

Cam followers with crowned O.D.s, hex holes,
and LUBRI-DISC® seals



See page 15 for hex
wrench sizes.
See page 14 for
crown details.

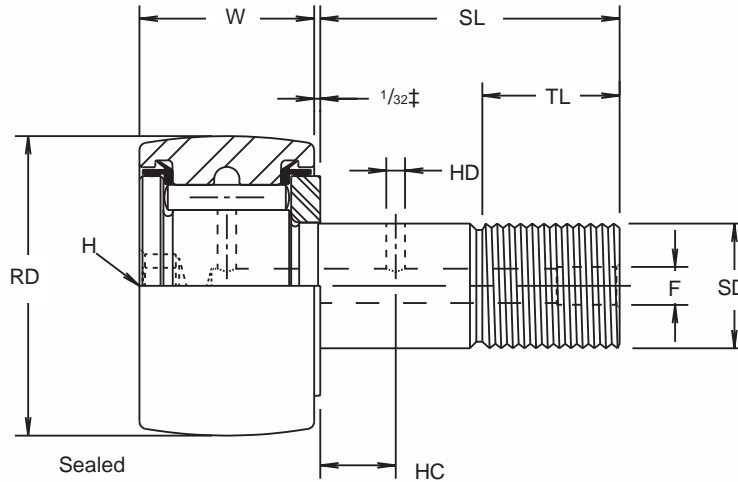

BRG. NO.	ROLLER DIA. (RD) +.000 -0.001	ROLLER WIDTH (W) +.000 -0.005	STUD DIA. (SD) +.001 -0.000	STUD L'GTH. (SL)	MIN. THR'D L'GTH. (TL)	FINE THR'DS.	OIL HOLE		LUB. FITTING SIZE (F)	MIN. BOSS DIA.	HOUSING BORE DIA. +.0002 -0.0003	***RECOM. CLAMPING TORQUE LBS.-IN.	MAX. STATIC CAPACITY LBS.	BASIC DYN. RATING LBS.
							HOLE CENTER (HC)	HOLE DIA. (HD)						
CCF-1/2-N-SB	.500	.344	.190	1/2	1/4	10-32	-	-	-	19/64	.1903	15	720	620
CCF-1/2-SB	.500	.375	.190	5/8	1/4	10-32	-	-	-	19/64	.1903	15	790	680
CCF-9/16-SB	.5625	.375	.190	5/8	1/4	10-32	-	-	-	19/64	.1903	15	790	680
CCF-5/8-N-SB	.625	.406	.250	5/8	5/16	1/4-28	-	-	-	23/64	.2503	35	1085	930
CCF-5/8-SB	.625	.4375	.250	3/4	5/16	1/4-28	-	-	-	23/64	.2503	35	1215	955
CCF-11/16-SB	.6875	.4375	.250	3/4	5/16	1/4-28	-	-	-	23/64	.2503	35	1215	955
CCF-3/4-SB	.750	.500	.375	7/8	3/8	3/8-24	1/4	3/32	3/16	1/2	.3753	95	2065	1660
CCF-7/8-SB	.875	.500	.375	7/8	3/8	3/8-24	1/4	3/32	3/16	1/2	.3753	95	2065	1660
CCF-1-SB	1.000	.625	.4375	1	1/2	7/16-20	1/4	3/32	3/16	41/64	.4378	250	3060	2225
CCF-1 1/8-SB	1.125	.625	.4375	1	1/2	7/16-20	1/4	3/32	3/16	41/64	.4378	250	3060	2225
CCF-1 1/4-SB	1.250	.750	.500	1 1/4	5/8	1/2-20	5/16	3/32	3/16	49/64	.5003	350	4250	3930
CCF-1 3/8-SB	1.375	.750	.500	1 1/4	5/8	1/2-20	5/16	3/32	3/16	49/64	.5003	350	4250	3930
CCF-1 1/2-SB	1.500	.875	.625	1 1/2	3/4	5/8-18	3/8	3/32	3/16	57/64	.6253	650	5640	4840
CCF-1 5/8-SB	1.625	.875	.625	1 1/2	3/4	5/8-18	3/8	3/32	3/16	57/64	.6253	650	5640	4840
CCF-1 3/4-SB	1.750	1.000	.750	1 3/4	7/8	3/4-16	7/16	3/32	3/16	1 3/64	.7503	1250	7920	6385
CCF-1 7/8-SB	1.875	1.000	.750	1 3/4	7/8	3/4-16	7/16	3/32	3/16	1 3/64	.7503	1250	7920	6385
CCF-2-SB	2.000	1.250	.875	2	1	7/8-14	1/2	1/8	3/16	1 13/64	.8753	1500	10570	8090
CCF-2 1/4-SB	2.250	1.250	.875	2	1	7/8-14	1/2	1/8	3/16	1 13/64	.8753	1500	10570	8090
CCF-2 1/2-SB	2.500	1.500	1.000	2 1/4	1 1/8	1-14	9/16	1/8	3/16	1 5/16	1.0003	2250	16450	11720
CCF-2 3/4-SB	2.750	1.500	1.000	2 1/4	1 1/8	1-14	9/16	1/8	3/16	1 5/16	1.0003	2250	16450	11720
CCF-3-SB	3.000	1.750	1.250	2 1/2	1 1/4	1 1/4-12	5/8	1/8	① 1/4	1 3/4	1.2503	3450	24910	15720
CCF-3 1/4-SB	3.250	1.750	1.250	2 1/2	1 1/4	1 1/4-12	5/8	1/8	① 1/4	1 3/4	1.2503	3450	24910	15720
CCF-3 1/2-SB	3.500	2.000	1.375	2 3/4	1 3/8	1 3/8-12	11/16	1/8	① 1/4	1 59/64	1.3753	4200	31625	22800
CCF-4-SB	4.000	2.250	1.500	3 1/2	1 1/2	1 1/2-12	3/4	1/8	① 1/4	2 9/32	1.5003	5000	44770	29985

*** Clamping torque is based on dry threads. If threads are lubricated, use half of values shown.
 ① Lubrication hole (F) at bottom of hex hole and 1/4 inch straight drive fitting with ball check supplied but not installed.
 Hex hole standard on sizes above CCF-4-SB.
 See page 21 for bearing dimensions.

Cam followers with crowned O.D.s, eccentric studs and LUBRI-DISC® seals



See page 14 for crown details.

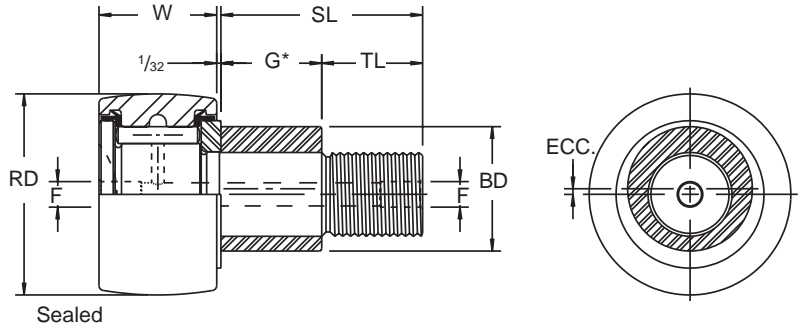

CAMROL® Bearings

BRG. NO.	ROLLER DIA. (RD) +.000 -.001	ROLLER WIDTH (W) +.000 -.005	BUSH. L'GTH. (G*) +.000 -.010	BUSH. DIA. (BD) ±.001	STUD L'GTH. (SL)	MIN. THR'D L'GTH. (TL)	FINE THR'D S.	ECC.	LUB. FITTING SIZE (F)**	***RECOM. CLAMPING TORQUE LBS.-IN.	MAX. STATIC CAPACITY LBS.	BASIC DYN. RATING LBS.
CCFE-1/2-N-S	.500	.344	.250	.250	1/2	1/4	10-32	.010	1/8**	15	720	620
CCFE-1/2-S	.500	.375	.375	.250	5/8	1/4	10-32	.010	1/8**	15	790	680
CCFE-9/16-S	.5625	.375	.375	.250	5/8	1/4	10-32	.010	1/8**	15	790	680
CCFE-5/8-S	.625	.4375	.437	.375	3/4	5/16	1/4-28	.015	1/8**	35	1215	955
CCFE-11/16-S	.6875	.4375	.437	.375	3/4	5/16	1/4-28	.015	1/8**	35	1215	955
CCFE-3/4-S	.750	.500	.500	.500	7/8	3/8	3/8-24	.015	3/16	95	2065	1660
CCFE-7/8-S	.875	.500	.500	.500	7/8	3/8	3/8-24	.015	3/16	95	2065	1660
CCFE-1-S	1.000	.625	.500	.625	1	1/2	7/16-20	.030	3/16	250	3060	2225
CCFE-1 1/8-S	1.125	.625	.500	.625	1	1/2	7/16-20	.030	3/16	250	3060	2225
CCFE-1 1/4-S	1.250	.750	.625	.687	1 1/4	5/8	1/2-20	.030	3/16	350	4250	3930
CCFE-1 3/8-S	1.375	.750	.625	.687	1 1/4	5/8	1/2-20	.030	3/16	350	4250	3930
CCFE-1 1/2-S	1.500	.875	.750	.875	1 1/2	3/4	5/8-18	.030	3/16	650	5640	4840
CCFE-1 5/8-S	1.625	.875	.750	.875	1 1/2	3/4	5/8-18	.030	3/16	650	5640	4840
CCFE-1 3/4-S	1.750	1.000	.875	1.000	1 3/4	7/8	3/4-16	.030	3/16	1250	7920	6385
CCFE-1 7/8-S	1.875	1.000	.875	1.000	1 3/4	7/8	3/4-16	.030	3/16	1250	7920	6385
CCFE-2-S	2.000	1.250	1.000	1.187	2	1	7/8-14	.030	3/16	1500	10570	8090
CCFE-2 1/4-S	2.250	1.250	1.000	1.187	2	1	7/8-14	.030	3/16	1500	10570	8090
CCFE-2 1/2-S	2.500	1.500	1.125	1.375	2 1/4	1 1/8	1-14	.030	3/16	2250	16450	11720
CCFE-2 3/4-S	2.750	1.500	1.125	1.375	2 1/4	1 1/8	1-14	.030	3/16	2250	16450	11720
CCFE-3-S	3.000	1.750	1.250	1.750	2 1/2	1 1/4	1 1/4-12	.060	1/4	3450	24910	15720
CCFE-3 1/4-S	3.250	1.750	1.250	1.750	2 1/2	1 1/4	1 1/4-12	.060	1/4	3450	24910	15720
CCFE-3 1/2-S	3.500	2.000	1.375	1.812	2 3/4	1 3/8	1 3/8-12	.060	1/4	4200	31625	22800
CCFE-4-S	4.000	2.250	2.000	2.000	3 1/2	1 1/2	1 1/2-12	.060	1/4	5000	44770	29985

* For positive clamping, use housing thickness equal to G dimension +.010. Bushing press fit on stem and unhardened to permit dowel or set screw for permanent locking. See page 15 for recommended housing bore diameter.

** Oil hole (F) drilled from the flange end of the stud to the radial oil hole only.

*** Clamping torque is based on dry threads. If threads are lubricated, use half of values shown.

CCFE-SB SERIES

Cam followers with crowned O.D.s, eccentric studs, hex holes, and LUBRI-DISC® seals



See page 15 for hex wrench sizes.
See page 14 for crown details.

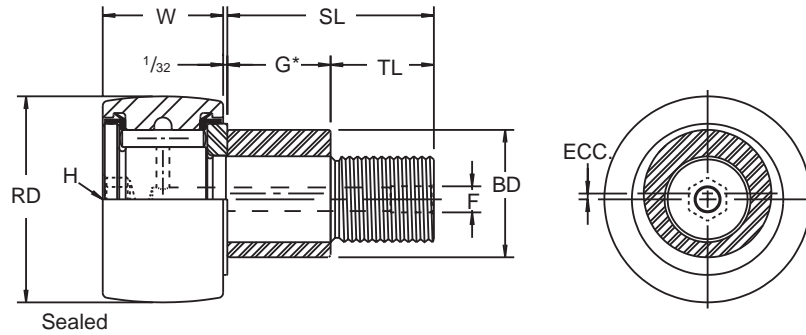

BRG. NO.	ROLLER DIA. (RD) +.000 -.001	ROLLER WIDTH (W) +.000 -.005	BUSH. L'GTH. (G*) +.000 -.010	BUSH. DIA. (BD) ±.001	STUD L'GTH. (SL)	MIN. THR'D L'GTH. (TL)	FINE THR'DS.	ECC.	LUB. FITTING SIZE (F)	**RECOM. CLAMPING TORQUE LBS.-IN.	MAX. STATIC CAPACITY LBS.	BASIC DYN. RATING LBS.
CCFE-1/2-N-SB	.500	.344	.250	.250	1/2	1/4	10-32	.010	-	15	720	620
CCFE-1/2-SB	.500	.375	.375	.250	5/8	1/4	10-32	.010	-	15	790	680
CCFE-9/16-SB	.5625	.375	.375	.250	5/8	1/4	10-32	.010	-	15	790	680
CCFE-5/8-SB	.625	.4375	.437	.375	3/4	5/16	1/4-28	.015	-	35	1215	955
CCFE-11/16-SB	.6875	.4375	.437	.375	3/4	5/16	1/4-28	.015	-	35	1215	955
CCFE-3/4-SB	.750	.500	.500	.500	7/8	3/8	3/8-24	.015	3/16	95	2065	1660
CCFE-7/8-SB	.875	.500	.500	.500	7/8	3/8	3/8-24	.015	3/16	95	2065	1660
CCFE-1-SB	1.000	.625	.500	.625	1	1/2	7/16-20	.030	3/16	250	3060	2225
CCFE-1 1/8-SB	1.125	.625	.500	.625	1	1/2	7/16-20	.030	3/16	250	3060	2225
CCFE-1 1/4-SB	1.250	.750	.625	.687	1 1/4	5/8	1/2-20	.030	3/16	350	4250	3930
CCFE-1 3/8-SB	1.375	.750	.625	.687	1 1/4	5/8	1/2-20	.030	3/16	350	4250	3930
CCFE-1 1/2-SB	1.500	.875	.750	.875	1 1/2	3/4	5/8-18	.030	3/16	650	5640	4840
CCFE-1 5/8-SB	1.625	.875	.750	.875	1 1/2	3/4	5/8-18	.030	3/16	650	5640	4840
CCFE-1 3/4-SB	1.750	1.000	.875	1.000	1 3/4	7/8	3/4-16	.030	3/16	1250	7920	6385
CCFE-1 7/8-SB	1.875	1.000	.875	1.000	1 3/4	7/8	3/4-16	.030	3/16	1250	7920	6385
CCFE-2-SB	2.000	1.250	1.000	1.187	2	1	7/8-14	.030	3/16	1500	10570	8090
CCFE-2 1/4-SB	2.250	1.250	1.000	1.187	2	1	7/8-14	.030	3/16	1500	10570	8090
CCFE-2 1/2-SB	2.500	1.500	1.125	1.375	2 1/4	1 1/8	1-14	.030	3/16	2250	16450	11720
CCFE-2 3/4-SB	2.750	1.500	1.125	1.375	2 1/4	1 1/8	1-14	.030	3/16	2250	16450	11720
CCFE-3-SB	3.000	1.750	1.250	1.750	2 1/2	1 1/4	1 1/4-12	.060	① 1/4	3450	24910	15720
CCFE-3 1/4-SB	3.250	1.750	1.250	1.750	2 1/2	1 1/4	1 1/4-12	.060	① 1/4	3450	24910	15720
CCFE-3 1/2-SB	3.500	2.000	1.375	1.812	2 3/4	1 3/8	1 3/8-12	.060	① 1/4	4200	31625	22800
CCFE-4-SB	4.000	2.250	2.000	2.000	3 1/2	1 1/2	1 1/2-12	.060	① 1/4	5000	44770	29985

* For positive clamping, use housing thickness equal to G dimension +.010. Bushing press fit on stem and unhardened to permit dowel or setscrew for permanent locking. See page 15 for recommended housing bore diameter.

** Clamping torque is based on dry threads. If threads are lubricated, use half of values shown.

① Lubrication hole (F) at bottom of hex hole and 1/4 inch straight drive fitting with ball check supplied but not installed.

CFH series heavy stud

Sealed and unsealed bearings showing optional features available in combination as shown in the following table (see following page).

Illustrated are 3 possible options available in heavy stud cam follower bearings. These may be combined to best serve any application and combinations regularly stocked are shown in the following table. Others would be special and should be discussed with the McGill Engineering Department.



CFH & CFH-S series heavy stud

Cam followers with and without LUBRI-DISC® seals



Unsealed



Sealed

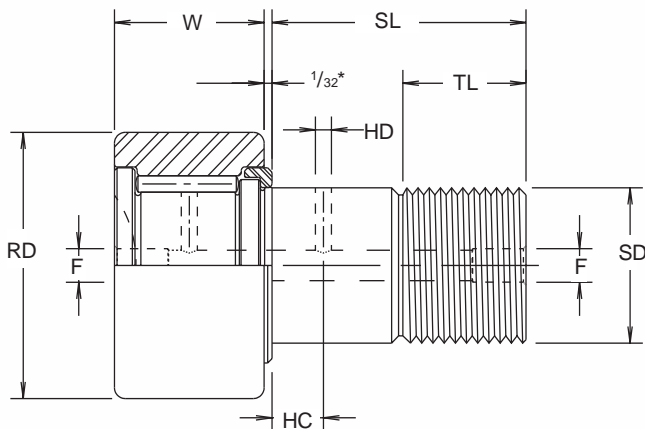

***1/16" on CFH-5, CFH-6, CFH-7**

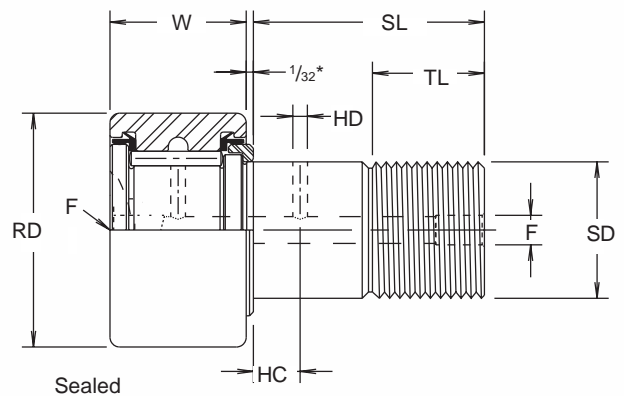

***1/16" on CFH-5-S, CFH-6-S, CFH-7-S**

CFH & CFH-S SERIES HEAVY STUD



With LUBRI-DISC® seals
add letter "S"
Ex. CFH-1³/₄-S



Hex Hole
add letter "B"
Ex. CFH-1³/₄-SB

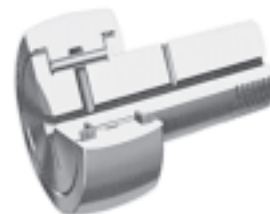

Crowned O.D.
add letter "C"
Ex. CCFH-1³/₄-S

UNSEALED BRG. NO.	SEALED BRG. NO.	ROLLER DIA. (RD) +.000 -.001	ROLLER WIDTH (W) +.000 -.005	STUD DIA. (SD) +.001 -.000	STUD L'GTH. (SL)	MIN. THR'D L'GTH. (TL)	FINE THR'DS.	OIL HOLE		LUB. FIT-TING SIZE (F)*	MIN. BOSS DIA.	HOUSING BORE DIA. +.0002 -.0003	**RECOM. CLAMPING TORQUE LBS.-IN.	MAX. STATIC CAPACITY LBS.	BASIC DYN. RATING LBS.
								HOLE CENTER (HC)	HOLE DIA. (HD)						
CFH-1/2	CFH-1/2-S	.500	.375	.250	5/8	1/4	1/4-28	-	-	1/8*	13/32	.2503	35	1580	680
CFH-9/16	CFH-9/16-S	.5625	.375	.250	5/8	1/4	1/4-28	-	-	1/8*	13/32	.2503	35	1580	680
CFH-5/8	CFH-5/8-S	.625	.4375	.3125	3/4	5/16	5/16-24	-	-	1/8*	15/32	.3128	90	2480	955
CFH-11/16	CFH-11/16-S	.6875	.4375	.3125	3/4	5/16	5/16-24	-	-	1/8*	15/32	.3128	90	2480	955
CFH-3/4	CFH-3/4-S	.750	.500	.4375	7/8	3/8	7/16-20	1/4	3/32	3/16	39/64	.4378	250	4130	1660
CFH-7/8	CFH-7/8-S	.875	.500	.4375	7/8	3/8	7/16-20	1/4	3/32	3/16	39/64	.4378	250	4130	1660
CFH-1	CFH-1-S	1.000	.625	.625	1	1/2	5/8-18	1/4	3/32	3/16	25/32	.6253	650	6120	2225
CFH-1 1/8	CFH-1 1/8-S	1.125	.625	.625	1	1/2	5/8-18	1/4	3/32	3/16	25/32	.6253	650	6120	2225
CFH-1 1/4	CFH-1 1/4-S	1.250	.750	.750	1 1/4	5/8	3/4-16	5/16	3/32	3/16	63/64	.7503	1250	8500	3930
CFH-1 3/8	CFH-1 3/8-S	1.375	.750	.750	1 1/4	5/8	3/4-16	5/16	3/32	3/16	63/64	.7503	1250	8500	3930
CFH-1 1/2	CFH-1 1/2-S	1.500	.875	.875	1 1/2	3/4	7/8-14	3/8	3/32	3/16	1 3/32	.8753	1500	11280	4840
CFH-1 5/8	CFH-1 5/8-S	1.625	.875	.875	1 1/2	3/4	7/8-14	3/8	3/32	3/16	1 3/32	.8753	1500	11280	4840
CFH-1 3/4	CFH-1 3/4-S	1.750	1.000	1.000	1 3/4	7/8	1-14	7/16	3/32	3/16	1 1/4	1.0003	2250	15840	6385
CFH-1 7/8	CFH-1 7/8-S	1.875	1.000	1.000	1 3/4	7/8	1-14	7/16	3/32	3/16	1 1/4	1.0003	2250	15840	6385
CFH-2	CFH-2-S	2.000	1.250	1.125	2	1	1 1/8-12	1/2	1/8	3/16	1 13/32	1.1253	2800	21140	8090
CFH-2 1/4	CFH-2 1/4-S	2.250	1.250	1.125	2	1	1 1/8-12	1/2	1/8	3/16	1 13/32	1.1253	2800	21140	8090
CFH-2 1/2	CFH-2 1/2-S	2.500	1.500	1.250	2 1/4	1 1/8	1 1/4-12	9/16	1/8	3/16	1 11/16	1.2503	3450	32900	11720
CFH-2 3/4	CFH-2 3/4-S	2.750	1.500	1.250	2 1/4	1 1/8	1 1/4-12	9/16	1/8	3/16	1 11/16	1.2503	3450	32900	11720
CFH-3	CFH-3-S	3.000	1.750	1.500	2 1/2	1 1/4	1 1/2-12	5/8	1/8	1/4	2 1/8	1.5003	5000	49820	15720
CFH-3 1/4	CFH-3 1/4-S	3.250	1.750	1.500	2 1/2	1 1/4	1 1/2-12	5/8	1/8	1/4	2 1/8	1.5003	5000	49820	15720
CFH-3 1/2	CFH-3 1/2-S	3.500	2.000	1.750	2 3/4	1 3/8	1 3/4-12	11/16	1/8	1/4	2 7/16	1.7503	5000	63250	22800
CFH-4	CFH-4-S	4.000	2.250	2.000	3 1/2	1 1/2	2-12	3/4	1/8	1/4	2 51/64	2.0003	5000	89540	29985
	CFH-5-S	5.000	2.750	2.500	5 1/16	2 9/16	2 1/2-12	7/8	3/16	1/4 N.P.T.	3 9/16	2.5003	5000	135900	46575
	CFH-6-S	6.000	3.250	3.000	6	3	3-12	1	3/16	1/4 N.P.T.	4 15/32	3.0003	5000	160900	60000
	CFH-7-S	7.000	3.750	3.500	7 11/16	4 1/8	3 1/2-4	1 1/4	3/16	1/4 N.P.T.	5 3/16	3.5003	5000	213860	75380

* Oil hole (F) drilled from the flange end of the stud to the radial oil hole only.
 ** Clamping torque is based on dry threads. If threads are lubricated, use half of values shown.
 • Coarse Thread.

Cam followers with hex holes, with and without LUBRI-DISC® seals



See page 15 for hex wrench sizes.

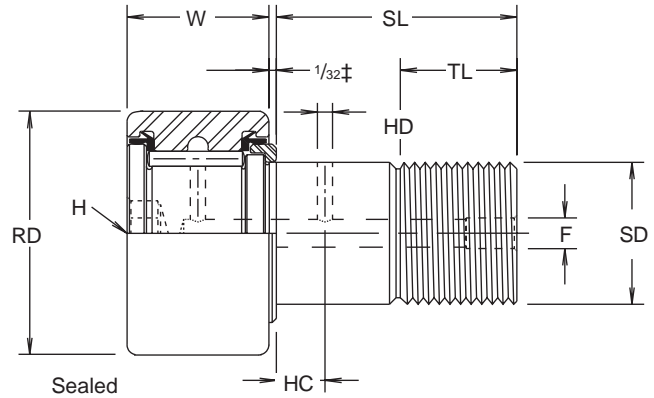

±1/16" on CFH-5-S, CFH-6-S, CFH-7-S

UNSEALED BRG. NO.	SEALED BRG. NO.	ROLLER DIA. (RD) +.000 -0.001	ROLLER WIDTH (W) +.000 -0.005	STUD DIA. (SD) +.001 -0.000	STUD L'GTH. (SL)	MIN. THR'D. L'GTH. (TL)	FINE THR'DS.	OIL HOLE		LUB. FITTING SIZE (F)	MIN. BOSS DIA.	HOUSING BORE DIA. +.0002 -0.0003	**RECOM. CLAMPING TORQUE LBS.-IN.	MAX. STATIC CAPACITY LBS.	BASIC DYN. RATING LBS.
								HOLE CENTER (HC)	HOLE DIA. (HD)						
CFH-1/2-B	CFH-1/2-SB	.500	.375	.250	5/8	1/4	1/4-28	-	-	-	13/32	.2503	35	1580	680
CFH-9/16-B	CFH-9/16-SB	.5625	.375	.250	5/8	1/4	1/4-28	-	-	-	13/32	.2503	35	1580	680
CFH-5/8-B	CFH-5/8-SB	.625	.4375	.3125	3/4	5/16	5/16-24	-	-	-	15/32	.3128	90	2480	955
CFH-11/16-B	CFH-11/16-SB	.6875	.4375	.3125	3/4	5/16	5/16-24	-	-	-	15/32	.3128	90	2480	955
CFH-3/4-B	CFH-3/4-SB	.750	.500	.4375	7/8	3/8	7/16-20	1/4	3/32	3/16	39/64	.4378	250	4130	1660
CFH-7/8-B	CFH-7/8-SB	.875	.500	.4375	7/8	3/8	7/16-20	1/4	3/32	3/16	39/64	.4378	250	4130	1660
CFH-1-B	CFH-1-SB	1.000	.625	.625	1	1/2	5/8-18	1/4	3/32	3/16	25/32	.6253	650	6120	2225
CFH-1 1/8-B	CFH-1 1/8-SB	1.125	.625	.625	1	1/2	5/8-18	1/4	3/32	3/16	25/32	.6253	650	6120	2225
CFH-1 1/4-B	CFH-1 1/4-SB	1.250	.750	.750	1 1/4	5/8	3/4-16	5/16	3/32	3/16	63/64	.7503	1250	8500	3930
CFH-1 3/8-B	CFH-1 3/8-SB	1.375	.750	.750	1 1/4	5/8	3/4-16	5/16	3/32	3/16	63/64	.7503	1250	8500	3930
CFH-1 1/2-B	CFH-1 1/2-SB	1.500	.875	.875	1 1/2	3/4	7/8-14	3/8	3/32	3/16	1 3/32	.8753	1500	11280	4840
CFH-1 5/8-B	CFH-1 5/8-SB	1.625	.875	.875	1 1/2	3/4	7/8-14	3/8	3/32	3/16	1 3/32	.8753	1500	11280	4840
CFH-1 3/4-B	CFH-1 3/4-SB	1.750	1.000	1.000	1 3/4	7/8	1-14	7/16	3/32	3/16	1 1/4	1.0003	2250	15840	6385
CFH-1 7/8-B	CFH-1 7/8-SB	1.875	1.000	1.000	1 3/4	7/8	1-14	7/16	3/32	3/16	1 1/4	1.0003	2250	15840	6385
CFH-2-B	CFH-2-SB	2.000	1.250	1.125	2	1	1 1/8-12	1/2	1/8	3/16	1 13/32	1.1253	2800	21140	8090
CFH-2 1/4-B	CFH-2 1/4-SB	2.250	1.250	1.125	2	1	1 1/8-12	1/2	1/8	3/16	1 13/32	1.1253	2800	21140	8090
CFH-2 1/2-B	CFH-2 1/2-SB	2.500	1.500	1.250	2 1/4	1 1/8	1 1/4-12	9/16	1/8	3/16	1 11/16	1.2503	3450	32900	11720
CFH-2 3/4-B	CFH-2 3/4-SB	2.750	1.500	1.250	2 1/4	1 1/8	1 1/4-12	9/16	1/8	3/16	1 11/16	1.2503	3450	32900	11720
CFH-3-B	CFH-3-SB	3.000	1.750	1.500	2 1/2	1 1/4	1 1/2-12	5/8	1/8	① 1/4	2 1/8	1.5003	5000	49820	15720
CFH-3 1/4-B	CFH-3 1/4-SB	3.250	1.750	1.500	2 1/2	1 1/4	1 1/2-12	5/8	1/8	① 1/4	2 1/8	1.5003	5000	49820	15720
CFH-3 1/2-B	CFH-3 1/2-SB	3.500	2.000	1.750	2 3/4	1 3/8	1 3/4-12	11/16	1/8	① 1/4	2 7/16	1.7503	5000	63250	22800
CFH-4-B	CFH-4-SB	4.000	2.250	2.000	3 1/2	1 1/2	2-12	3/4	1/8	① 1/4	2 51/64	2.0003	5000	89540	29985

** Clamping torque is based on dry threads. If threads are lubricated, use half of values shown.
 ① Lubrication hole (F) at bottom of hex hole and 1/4 inch straight drive fitting with ball check supplied but not installed.
 Hex hole standard on sizes above CFH-4-SB.
 See page 26 for bearing dimensions.

CCFH-S SERIES HEAVY STUD

Cam followers with crowned O.D.s and LUBRI-DISC® seals

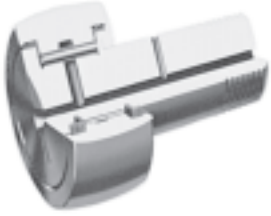

See page 14 for crown details.

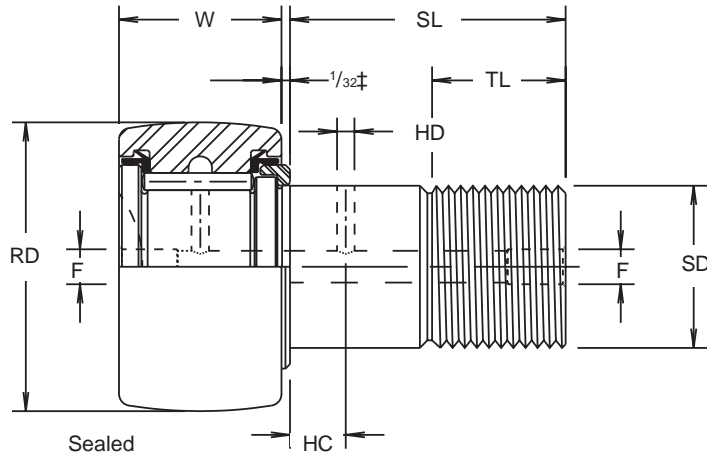

±1/16" on CCFH-5-S, CCFH-6-S, CCFH-7-S

BRG. NO.	ROLLER DIA. (RD) +.000 -.001	ROLLER WIDTH (W) +.000 -.005	STUD DIA. (SD) +.001 -.000	STUD L'GTH. (SL)	MIN. THR'D L'GTH. (TL)	FINE THR'DS.	OIL HOLE		LUB. FITTING SIZE (F)*	MIN. BOSS DIA.	HOUSING BORE DIA. +.0002 -.0003	**RECOM. CLAMPING TORQUE LBS.-IN.	MAX. STATIC CAPACITY LBS.	BASIC DYN. RATING LBS.
							HOLE CENTER (HC)	HOLE DIA. (HD)						
CCFH-1/2-S	.500	.375	.250	5/8	1/4	1/4-28	-	-	1/8*	13/32	.2503	35	1580	680
CCFH-9/16-S	.5625	.375	.250	5/8	1/4	1/4-28	-	-	1/8*	13/32	.2503	35	1580	680
CCFH-5/8-S	.625	.4375	.3125	3/4	5/16	5/16-24	-	-	1/8*	15/32	.3128	90	2480	955
CCFH-11/16-S	.6875	.4375	.3125	3/4	5/16	5/16-24	-	-	1/8*	15/32	.3128	90	2480	955
CCFH-3/4-S	.750	.500	.4375	7/8	3/8	7/16-20	1/4	3/32	3/16	39/64	.4378	250	4130	1660
CCFH-7/8-S	.875	.500	.4375	7/8	3/8	7/16-20	1/4	3/32	3/16	39/64	.4378	250	4130	1660
CCFH-1-S	1.000	.625	.625	1	1/2	5/8-18	1/4	3/32	3/16	25/32	.6253	650	6120	2225
CCFH-1 1/8-S	1.125	.625	.625	1	1/2	5/8-18	1/4	3/32	3/16	25/32	.6253	650	6120	2225
CCFH-1 1/4-S	1.250	.750	.750	1 1/4	5/8	3/4-16	5/16	3/32	3/16	63/64	.7503	1250	8500	3930
CCFH-1 3/8-S	1.375	.750	.750	1 1/4	5/8	3/4-16	5/16	3/32	3/16	63/64	.7503	1250	8500	3930
CCFH-1 1/2-S	1.500	.875	.875	1 1/2	3/4	7/8-14	3/8	3/32	3/16	1 3/32	.8753	1500	11280	4840
CCFH-1 5/8-S	1.625	.875	.875	1 1/2	3/4	7/8-14	3/8	3/32	3/16	1 3/32	.8753	1500	11280	4840
CCFH-1 3/4-S	1.750	1.000	1.000	1 3/4	7/8	1-14	7/16	3/32	3/16	1 1/4	1.0003	2250	15840	6385
CCFH-1 7/8-S	1.875	1.000	1.000	1 3/4	7/8	1-14	7/16	3/32	3/16	1 1/4	1.0003	2250	15840	6385
CCFH-2-S	2.000	1.250	1.125	2	1	1 1/8-12	1/2	1/8	3/16	1 13/32	1.1253	2800	21140	8090
CCFH-2 1/4-S	2.250	1.250	1.125	2	1	1 1/8-12	1/2	1/8	3/16	1 13/32	1.1253	2800	21140	8090
CCFH-2 1/2-S	2.500	1.500	1.250	2 1/4	1 1/8	1 1/4-12	9/16	1/8	3/16	1 11/16	1.2503	3450	32900	11720
CCFH-2 3/4-S	2.750	1.500	1.250	2 1/4	1 1/8	1 1/4-12	9/16	1/8	3/16	1 11/16	1.2503	3450	32900	11720
CCFH-3-S	3.000	1.750	1.500	2 1/2	1 1/4	1 1/2-12	5/8	1/8	1/4	2 1/8	1.5003	5000	49820	15720
CCFH-3 1/4-S	3.250	1.750	1.500	2 1/2	1 1/4	1 1/2-12	5/8	1/8	1/4	2 1/8	1.5003	5000	49820	15720
CCFH-3 1/2-S	3.500	2.000	1.750	2 3/4	1 3/8	1 3/4-12	11/16	1/8	1/4	2 7/16	1.7503	5000	63250	22800
CCFH-4-S	4.000	2.250	2.000	3 1/2	1 1/2	2-12	3/4	1/8	1/4	2 51/64	2.0003	5000	89540	29985
†CCFH-5-S	5.000	2.750	2.500	5 1/16	2 9/16	2 1/2-12	7/8	3/16	1/4 N.P.T.	3 9/16	2.5003	5000	135900	46575
†CCFH-6-S	6.000	3.250	3.000	6	3	3-12	1	3/16	1/4 N.P.T.	4 15/32	3.0003	5000	160900	60000
†CCFH-7-S	7.000	3.750	3.500	7 11/16	4 1/8	3 1/2-4	1 1/4	3/16	1/4 N.P.T.	5 3/16	3.5003	5000	213860	75380

† Not available from stock. Consult McGill Customer Service for availability.
 • Coarse Thread.
 * Oil hole (F) drilled from the flange end of the stud to the radial oil hole only.
 ** Clamping torque is based on dry threads. If threads are lubricated, use half of values shown.

Cam followers with crowned O.D.s, hex holes and LUBRI-DISC® seals

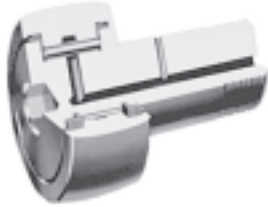

See page 15 for hex wrench sizes.
See page 14 for crown details.

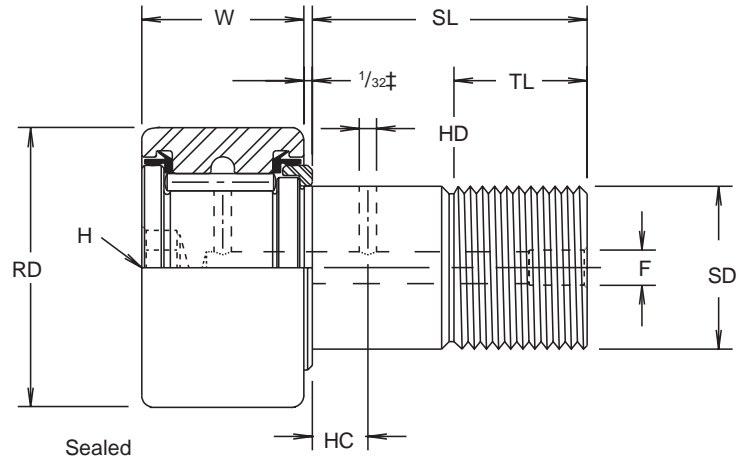

CAMROL® Bearings

BRG. NO.	ROLLER DIA. (RD) +.000 -.001	ROLLER WIDTH (W) +.000 -.005	STUD DIA. (SD) +.001 -.000	STUD L'GTH. (SL)	MIN. THR'D L'GTH. (TL)	FINE THR'DS.	OIL HOLE		LUB. FITTING SIZE (F)	MIN. BOSS DIA.	HOUSING BORE DIA. +.0002 -.0003	*RECOM. CLAMPING TORQUE LBS.-IN.	MAX. STATIC CAPACITY LBS.	BASIC DYN. RATING LBS.
							HOLE CENTER (HC)	HOLE DIA. (HD)						
CCFH-1/2-SB	.500	.375	.250	5/8	1/4	1/4-28	-	-	-	13/32	.2503	35	1580	680
CCFH-9/16-SB	.5625	.375	.250	5/8	1/4	1/4-28	-	-	-	13/32	.2503	35	1580	680
CCFH-5/8-SB	.625	.4375	.3125	3/4	5/16	5/16-24	-	-	-	15/32	.3128	90	2480	955
CCFH-11/16-SB	.6875	.4375	.3125	3/4	5/16	5/16-24	-	-	-	15/32	.3128	90	2480	955
CCFH-3/4-SB	.750	.500	.4375	7/8	3/8	7/16-20	1/4	3/32	3/16	39/64	.4378	250	4130	1660
CCFH-7/8-SB	.875	.500	.4375	7/8	3/8	7/16-20	1/4	3/32	3/16	39/64	.4378	250	4130	1660
CCFH-1-SB	1.000	.625	.625	1	1/2	5/8-18	1/4	3/32	3/16	25/32	.6253	650	6120	2225
CCFH-1 1/8-SB	1.125	.625	.625	1	1/2	5/8-18	1/4	3/32	3/16	25/32	.6253	650	6120	2225
CCFH-1 1/4-SB	1.250	.750	.750	1 1/4	5/8	3/4-16	5/16	3/32	3/16	63/64	.7503	1250	8500	3930
CCFH-1 3/8-SB	1.375	.750	.750	1 1/4	5/8	3/4-16	5/16	3/32	3/16	63/64	.7503	1250	8500	3930
CCFH-1 1/2-SB	1.500	.875	.875	1 1/2	3/4	7/8-14	3/8	3/32	3/16	1 3/32	.8753	1500	11280	4840
CCFH-1 5/8-SB	1.625	.875	.875	1 1/2	3/4	7/8-14	3/8	3/32	3/16	1 3/32	.8753	1500	11280	4840
CCFH-1 3/4-SB	1.750	1.000	1.000	1 3/4	7/8	1-14	7/16	3/32	3/16	1 1/4	1.0003	2250	15840	6385
CCFH-1 7/8-SB	1.875	1.000	1.000	1 3/4	7/8	1-14	7/16	3/32	3/16	1 1/4	1.0003	2250	15840	6385
CCFH-2-SB	2.000	1.250	1.125	2	1	1 1/8-12	1/2	1/8	3/16	1 13/32	1.1253	2800	21140	8090
CCFH-2 1/4-SB	2.250	1.250	1.125	2	1	1 1/8-12	1/2	1/8	3/16	1 13/32	1.1253	2800	21140	8090
CCFH-2 1/2-SB	2.500	1.500	1.250	2 1/4	1 1/8	1 1/4-12	9/16	1/8	3/16	1 11/16	1.2503	3450	32900	11720
CCFH-2 3/4-SB	2.750	1.500	1.250	2 1/4	1 1/8	1 1/4-12	9/16	1/8	3/16	1 11/16	1.2503	3450	32900	11720
CCFH-3-SB	3.000	1.750	1.500	2 1/2	1 1/4	1 1/2-12	5/8	1/8	① 1/4	2 1/8	1.5003	5000	49820	15720
CCFH-3 1/4-SB	3.250	1.750	1.500	2 1/2	1 1/4	1 1/2-12	5/8	1/8	① 1/4	2 1/8	1.5003	5000	49820	15720
CCFH-3 1/2-SB	3.500	2.000	1.750	2 3/4	1 3/8	1 3/4-12	11/16	1/8	① 1/4	2 7/16	1.7503	5000	63250	22800
CCFH-4-SB	4.000	2.250	2.000	3 1/2	1 1/2	2-12	3/4	1/8	① 1/4	2 51/64	2.0003	5000	89540	29985

* Clamping torque is based on dry threads. If threads are lubricated, use half of values shown.
① Lubrication hole (F) at bottom of hex hole and 1/4 inch straight drive fitting with ball check supplied but not installed.
Hex hole standard on sizes above CCFH-4-SB.
See page 28 for bearing dimensions.

CYR SERIES CAM YOKE ROLLER, CYR, CYR-S, & CCYR-S SERIES

CYR series cam yoke roller

Cam follower type bearings without studs for shaft mounting — sealed (with or without crowned O.D.), and unsealed.

Illustrated are the options available in cam yoke roller bearings. These may be combined to best serve any application and combinations regularly stocked are shown in the following table. Others would be special and should be discussed with the McGill Engineering Department.

CYR, CYR-S & CCYR-S series

Cam followers without studs for shaft mounting, with and without LUBRI-DISC® seals



Unsealed



With LUBRI-DISC seals

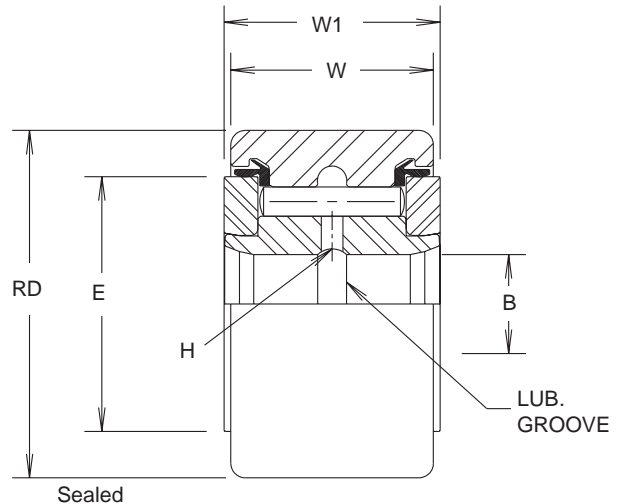
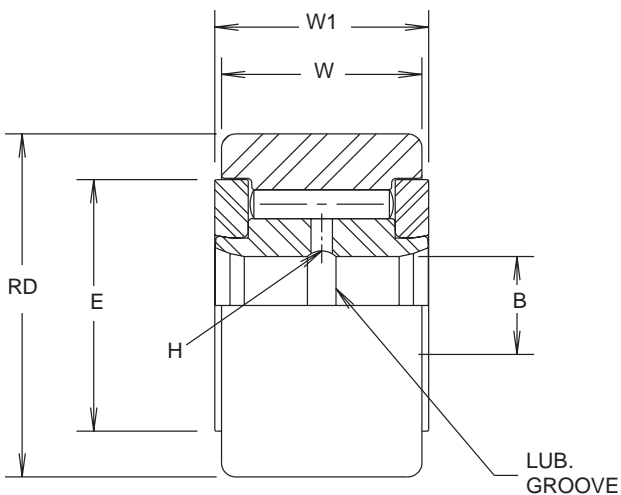

CYR SERIES CAM YOKE, CYR, CYR-S, & CCYR-S SERIES



With LUBRI-DISC® seals
add letter "S"
Ex. CYR-1^{3/4}-S



Crowned O.D.
add letter "C"
Ex. CCYR-1^{3/4}-S

See page 14 for crown details.

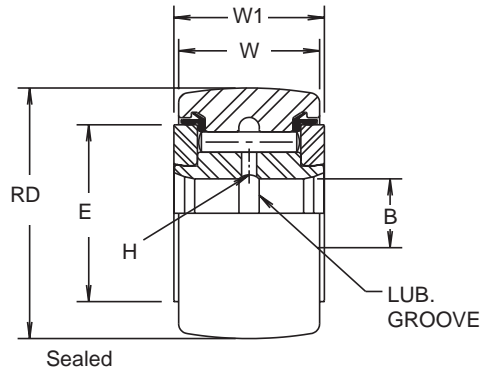

CYR, CYR-S & CCYR-S series

Cam followers without studs for shaft mounting, with and without LUBRI-DISC® seals

UNSEALED BRG. NO.	SEALED BRG. NO.	SEALED BRG. NO.	ROLLER DIA. (RD) +.000 -.001	ROLLER WIDTH (W) +.000 -.005	BORE (B)		WIDTH OVER END PLATES (W1) +.005 -.010	DIA. OF END PLATES (E)	OIL HOLE (H) DIA.	MIN. BOSS DIA.	SHAFT DIA.						MAX. STATIC CAPACITY LBS.	BASIC DYN. RATING LBS.
					NOM.	TOL.					PUSH FIT		DRIVE FIT		PRESS FIT			
											NOM.	TOL.	NOM.	TOL.	NOM.	TOL.		
CYR-3/4	CYR-3/4-S	CCYR-3/4-S	.750	.500	.250		.5625	39/64		1/2	.2495		.2501		.2503		4130	1660
CYR-7/8	CYR-7/8-S	CCYR-7/8-S	.875	.500	.250		.5625	39/64		1/2	.2495		.2501		.2503		4130	1660
CYR-1	CYR-1-S	CCYR-1-S	1.000	.625	.3125		.6875	25/32		41/64	.3120		.3126		.3128		6120	2225
CYR-1 1/8	CYR-1 1/8-S	CCYR-1 1/8-S	1.125	.625	.3125		.6875	25/32		41/64	.3120		.3126		.3128		6120	2225
CYR-1 1/4	CYR-1 1/4-S	CCYR-1 1/4-S	1.250	.750	.375		.8125	63/64		49/64	.3745		.3751		.3753		8500	3930
CYR-1 3/8	CYR-1 3/8-S	CCYR-1 3/8-S	1.375	.750	.375		.8125	63/64		49/64	.3745		.3751		.3753		8500	3930
CYR-1 1/2	CYR-1 1/2-S	CCYR-1 1/2-S	1.500	.875	.4375	+.0002	.9375	1 3/32	3/32	57/64	.4370	±.0002	.4376	±.0002	.4378	±.0002	11280	4840
CYR-1 5/8	CYR-1 5/8-S	CCYR-1 5/8-S	1.625	.875	.4375	-.0004	.9375	1 3/32		57/64	.4370		.4376		.4378		11280	4840
CYR-1 3/4	CYR-1 3/4-S	CCYR-1 3/4-S	1.750	1.000	.500		1.0625	1 1/4		1 3/64	.4995		.5001		.5005		15840	6385
CYR-1 7/8	CYR-1 7/8-S	CCYR-1 7/8-S	1.875	1.000	.500		1.0625	1 1/4		1 3/64	.4995		.5001		.5005		15840	6385
CYR-2	CYR-2-S	CCYR-2-S	2.000	1.250	.625		1.3125	1 13/32		1 13/64	.6245		.6251		.6255		21140	8090
CYR-2 1/4	CYR-2 1/4-S	CCYR-2 1/4-S	2.250	1.250	.625		1.3125	1 13/32		1 13/64	.6245		.6251		.6255		21140	8090
CYR-2 1/2	CYR-2 1/2-S	CCYR-2 1/2-S	2.500	1.500	.750		1.5625	1 11/16		1 5/16	.7495		.7501		.7505		32900	11720
CYR-2 3/4	CYR-2 3/4-S	CCYR-2 3/4-S	2.750	1.500	.750		1.5625	1 11/16		1 5/16	.7495		.7501		.7505		32900	11720
CYR-3	CYR-3-S	CCYR-3-S	3.000	1.750	1.000		1.8125	2 1/8	1/8	1 3/4	.9994		1.0002		1.0006		49820	15720
CYR-3 1/4	CYR-3 1/4-S	CCYR-3 1/4-S	3.250	1.750	1.000		1.8125	2 1/8		1 3/4	.9994		1.0002		1.0006		49820	15720
CYR-3 1/2	CYR-3 1/2-S	CCYR-3 1/2-S	3.500	2.000	1.125		2.0625	2 7/16		1 59/64	1.1244		1.1252		1.1256		63250	22800
CYR-4	CYR-4-S	CCYR-4-S	4.000	2.250	1.250	+.0001 -.0005	2.3125	2 51/64		2 9/32	1.2494		1.2502	±.0002 -.0003	1.2506	±.0002 -.0003	89540	29985
	CYR-5-S	†CCYR-5-S	5.000	2.750	1.750		2.8750	3 9/16		2 7/8	1.7494		1.7502		1.7506		135900	46575
	CYR-6-S	†CCYR-6-S	6.000	3.250	2.250		3.3750	4 15/32	3/16	3 3/8	2.2494		2.2502		2.2506		160900	60000
	CYR-7-S	†CCYR-7-S	7.000	3.750	2.750		3.8750	5 3/16		3 7/8	2.7494		2.7502		2.7506		213860	75380
	†CYR-8-S	†CCYR-8-S	8.000	4.250	3.255		4.5000	4 3/8	1/4	4 3/8	3.2545		3.2560		3.2565		288200	92200
	†CYR-9-S	†CCYR-9-S	9.000	4.750	3.755	+.001 -.000	5.0000	5 1/16	5/16	5 1/16	3.7545	±.0005	3.7560	±.0005	3.7565	±.0005	366850	113260
	†CYR-10-S	†CCYR-10-S	10.000	5.250	4.255		5.5000	5 15/32	3/8	5 15/32	4.2545		4.2560		4.2565		431130	131545

† Not available from stock. Consult McGill Customer Service for availability.
 ♦ Standard tolerances do not apply. Consult McGill Customer Service.
 NOTE: Consult McGill Customer Service for limiting speeds.

BCF-S & BCYR-S SERIES BUSHING TYPE**Non-metallic bushing replaces rollers****Non-Metallic bushings eliminate need for lubrication where undesirable**

Replacing rollers, a non-metallic bushing provides load support and a sliding motion that eliminates or reduces need for bearing lubrication. The CAMROL® bearing BCF-S series with integral studs and the BCYR-S series (yoke roller type) without studs are recommended for use where relubrication is not convenient or where the possibility of grease contamination of the product being processed is not acceptable.

The CAMROL® bushing type cam follower is standard in roller sizes from 1/2" to 4" and double sealed. LUBRI-DISC®

rings reduce internal friction for longer life. Optional features, also available, include crowned OD, hex hole for hex wrench mounting, and eccentric stud.

Maximum allowable continuous operating temperature is up to 200°F. Bushing CAMROL® bearings are intended to be used in the self-lubricated mode. However, continuous feed oil lubrication can be used to provide reduced wear rates. Grease lubrication should not be used.

The bushing type CAMROL® is not recommended for food machinery applications where contact with food products may occur.

LOAD-SPEED CHART

Values based on continuous rotation and no lubrication

To determine maximum bearing capacity at a given speed, read vertical load scale under basic bearing size under consideration at proper speed.

Example:

Determine load capacity of BCF-³/₄-S at 100 RPM. Read down vertical load scale under basic ³/₄ size to intersection of horizontal line for maximum speed of 100 RPM.

Load rating would be 100 pounds.

To determine minimum bearing size required for application, draw horizontal line through application speed until application load can be read on one of the vertical load scales. The basic bearing size can then be read at the top of the column.

Example:

Application speed = 200 RPM
 Application load = 50 pounds

Minimum basic bearing size required would be a BCF or BCYR - ¹/₄-S.

ROLLER DIA. (RD)	1/2	5/8	3/4	1	1 1/4	1 1/2	1 3/4	2	2 1/2	3	3 1/2	4
	8	8	8	8	8	8	8	8	8	8	8	8
	9/16	11/16	7/8	1 1/8	1 3/8	1 5/8	1 7/8	2 1/4	2 3/4	3 1/4		

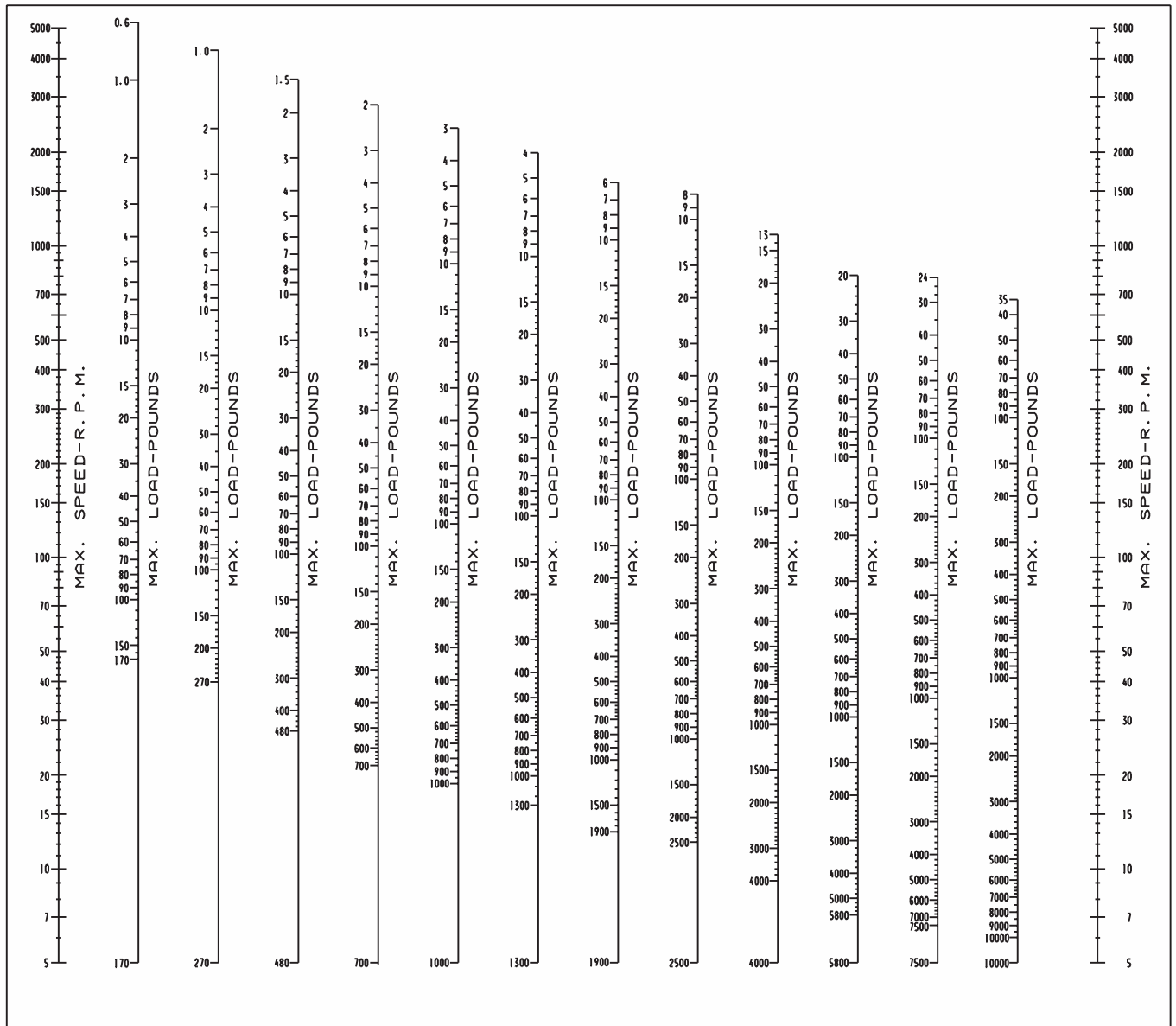

There are many application conditions which could improve or reduce the permissible load carrying capacity of these bearings. Therefore, we recommend that McGill Engineering Department be consulted for your specific application.

BCF-S SERIES BUSHING TYPE

Cam followers with LUBRI-DISC® seals and non-metallic bushings instead of rollers

In this series a non-metallic bushing replaces rollers and provides load support and a sliding motion that eliminates or reduces need for bearing lubrication.

See page 33 for maximum load capacity at any given speed.

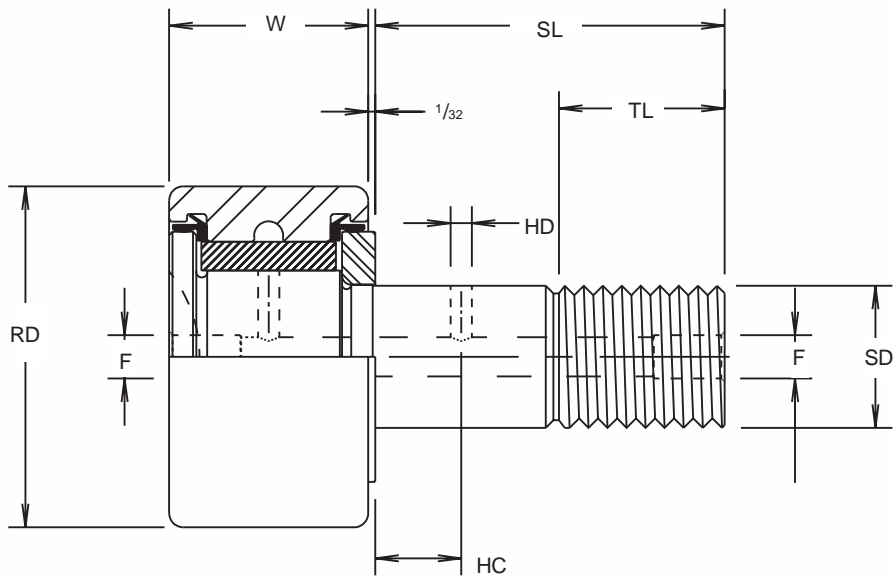
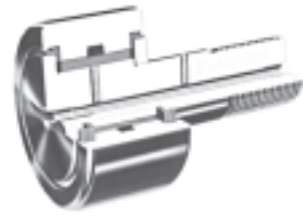



Crowned O. D.
 add letter "C"
 Ex. BCCF-1³/₄-S



Hex Hole
 add letter "B"
 Ex. BCF-1³/₄-SB



Eccentric Stud
 add letter "E"
 Ex. BCFE-1³/₄-SB

CAMROL®
 Bearings

BRG. NO.	ROLLER DIA. (RD) +.000 -.001	ROLLER WIDTH (W) +.000 -.005	STUD DIA. (SD) +.001 -.000	STUD L'GTH. (SL)	MIN. THR'D. L'GTH. (TL)	FINE THR'DS.	OIL HOLE		LUB. FITTING SIZE (F)*	MIN. BOSS DIA.	HOUSING BORE DIA. +.0002 -.0003	**RECOM. CLAMPING TORQUE LBS.-IN.
							HOLE CENTER (HC)	HOLE DIA. (HD)				
BCF-1/2-S	.500	.375	.190	5/8	1/4	10-32	-	-	1/8*	19/64	.1903	15
BCF-9/16-S	.5625	.375	.190	5/8	1/4	10-32	-	-	1/8*	19/64	.1903	15
BCF-5/8-S	.625	.4375	.250	3/4	5/16	1/4-28	-	-	1/8*	23/64	.2503	35
BCF-11/16-S	.6875	.4375	.250	3/4	5/16	1/4-28	-	-	1/8*	23/64	.2503	35
BCF-3/4-S	.750	.500	.375	7/8	3/8	3/8-24	1/4	3/32	3/16	1/2	.3753	95
BCF-7/8-S	.875	.500	.375	7/8	3/8	3/8-24	1/4	3/32	3/16	1/2	.3753	95
BCF-1-S	1.000	.625	.4375	1	1/2	7/16-20	1/4	3/32	3/16	41/64	.4378	250
BCF-1 1/8-S	1.125	.625	.4375	1	1/2	7/16-20	1/4	3/32	3/16	41/64	.4378	250
BCF-1 1/4-S	1.250	.750	.500	1 1/4	5/8	1/2-20	5/16	3/32	3/16	49/64	.5003	350
BCF-1 3/8-S	1.375	.750	.500	1 1/4	5/8	1/2-20	5/16	3/32	3/16	49/64	.5003	350
BCF-1 1/2-S	1.500	.875	.625	1 1/2	3/4	5/8-18	3/8	3/32	3/16	57/64	.6253	650
BCF-1 5/8-S	1.625	.875	.625	1 1/2	3/4	5/8-18	3/8	3/32	3/16	57/64	.6253	650
BCF-1 3/4-S	1.750	1.000	.750	1 3/4	7/8	3/4-16	7/16	3/32	3/16	1 3/64	.7503	1250
BCF-1 7/8-S	1.875	1.000	.750	1 3/4	7/8	3/4-16	7/16	3/32	3/16	1 3/64	.7503	1250
BCF-2-S	2.000	1.250	.875	2	1	7/8-14	1/2	1/8	3/16	1 13/64	.8753	1500
BCF-2 1/4-S	2.250	1.250	.875	2	1	7/8-14	1/2	1/8	3/16	1 13/64	.8753	1500
BCF-2 1/2-S	2.500	1.500	1.000	2 1/4	1 1/8	1-14	9/16	1/8	3/16	1 5/16	1.0003	2250
BCF-2 3/4-S	2.750	1.500	1.000	2 1/4	1 1/8	1-14	9/16	1/8	3/16	1 5/16	1.0003	2250
BCF-3-S	3.000	1.750	1.250	2 1/2	1 1/4	1 1/4-12	5/8	1/8	1/4	1 3/4	1.2503	3450
BCF-3 1/4-S	3.250	1.750	1.250	2 1/2	1 1/4	1 1/4-12	5/8	1/8	1/4	1 3/4	1.2503	3450
BCF-3 1/2-S	3.500	2.000	1.375	2 3/4	1 3/8	1 3/8-12	11/16	1/8	1/4	1 59/64	1.3753	4200
BCF-4-S	4.000	2.250	1.500	3 1/2	1 1/2	1 1/2-12	3/4	1/8	1/4	2 9/32	1.5003	5000

* Oil hole (F) drilled from the flange end of the stud to the radial oil hole only.
 Bushing Type CAMROL® Bearings are designed for operation without lubrication at service temperatures from -40°F. to +200°F. (+250°F. for short duration).
 Not all sizes in stock. Consult McGill Customer Service for availability.
 To identify crowned OD option, add the prefix C to the standard bearing catalog number—EX-BCCF-1/2-S.
 For hex hole models add suffix B—EX-BCF-1/2-SB. For eccentric stud models add prefix E—EX-BCFE-1/2-S.
 ** Clamping torque is based on dry threads. If threads are lubricated, use half of values shown.

BCYR-S SERIES BUSHING TYPE

Cam followers without studs for shaft mounting with LUBRI-DISC® seals and non-metallic bushings instead of rollers

In this series a non-metallic bushing replaces rollers and provides load support and a sliding motion that eliminates or reduces need for bearing lubrication.

See page 33 for maximum load capacity at any given speed.

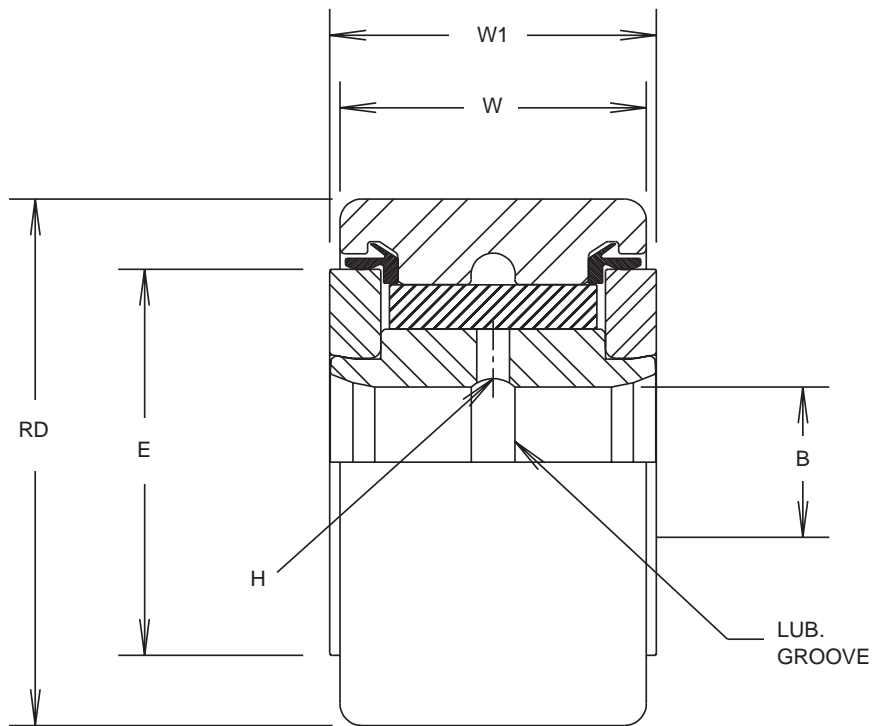



Crowned O. D.
 add letter "C"
 Ex. BCCYR-1³/₄-S

See page 14 for
 crown details.

BRG. NO.	ROLLER DIA. (RD) +.000 -.001	ROLLER WIDTH (W) +.000 -.005	BORE (B)		WIDTH OVER END PLATES (W1) +.005 -.010	DIA. OF END PLATES (E)	OIL HOLE (H) DIA.	MIN. BOSS DIA.	SHAFT DIA.					
			NOM.	TOL.					PUSH FIT		DRIVE FIT		PRESS FIT	
									NOM.	TOL.	NOM.	TOL.	NOM.	TOL.
BCYR-3/4-S	.750	.500	.250	+.0002 -.0004	.5625	39/64	3/32	1/2	.2495	±.0002	.2501	±.0002	.2503	±.0002
BCYR-7/8-S	.875	.500	.250		.5625	39/64	3/32	1/2	.2495		.2501		.2503	
BCYR-1-S	1.000	.625	.3125		.6875	25/32	3/32	41/64	.3120		.3126		.3128	
BCYR-1 1/8-S	1.125	.625	.3125		.6875	25/32	3/32	41/64	.3120		.3126		.3128	
BCYR-1 1/4-S	1.250	.750	.375		.8125	63/64	3/32	49/64	.3745		.3751		.3753	
BCYR-1 3/8-S	1.375	.750	.375		.8125	63/64	3/32	49/64	.3745		.3751		.3753	
BCYR-1 1/2-S	1.500	.875	.4375		.9375	1 3/32	3/32	57/64	.4370		.4376		.4378	
BCYR-1 5/8-S	1.625	.875	.4375		.9375	1 3/32	3/32	57/64	.4370		.4376		.4378	
BCYR-1 3/4-S	1.750	1.000	.500		1.0625	1 1/4	3/32	1 3/64	.4995		.5001		.5005	
BCYR-1 7/8-S	1.875	1.000	.500		1.0625	1 1/4	3/32	1 3/64	.4995		.5001		.5005	
BCYR-2-S	2.000	1.250	.625		1.3125	1 13/32	3/32	1 13/64	.6245		.6251		.6255	
BCYR-2 1/4-S	2.250	1.250	.625		1.3125	1 13/32	3/32	1 13/64	.6245		.6251		.6255	
BCYR-2 1/2-S	2.500	1.500	.750		1.5625	1 11/16	1/8	1 5/16	.7495		.7501		.7505	
BCYR-2 3/4-S	2.750	1.500	.750		1.5625	1 11/16	1/8	1 5/16	.7495		.7501		.7505	
BCYR-3-S	3.000	1.750	1.000	1.8125	2 1/8	1/8	1 3/4	.9994	1.0002	1.0006				
BCYR-3 1/4-S	3.250	1.750	1.000	1.8125	2 1/8	1/8	1 3/4	.9994	1.0002	1.0006				
BCYR-3 1/2-S	3.500	2.000	1.125	2.0625	2 7/16	1/8	1 59/64	1.1244	1.1252	1.1256				
BCYR-4-S	4.000	2.250	1.250	2.3125	2 51/64	1/8	2 9/32	1.2494	1.2502	1.2506				

Bushing Type CAMROL® Bearings are designed for operation without lubrication at service temperatures from -40°F. to +200°F. (+250°F. for short duration).
 Not all sizes in stock. Consult McGill Customer Service for availability.
 To identify crowned OD option, add the prefix C to the standard bearing catalog number—EX-BCCYR-³/₄-S.

CYR SERIES & CF-S SERIES (SEALED)

BEARING APPLICATIONS

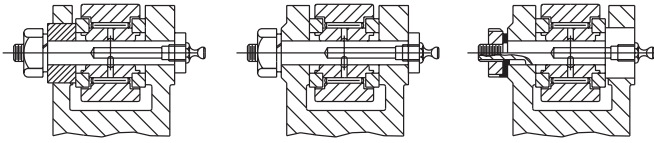

Yoke Mountings

Three recommended methods of yoke mounting CAMROL® CYR Series bearings.

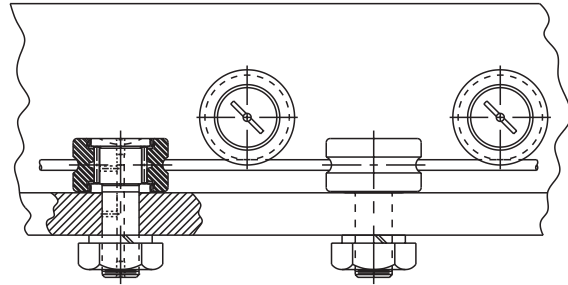

Wire Straightening Rollers

Special grooved outer race CAMROL® CF-Series bearings result in a low cost bearing, easily mounted for wire straightener and similar applications. The sealed bearing resists the highly contaminate scale present with wire processing.

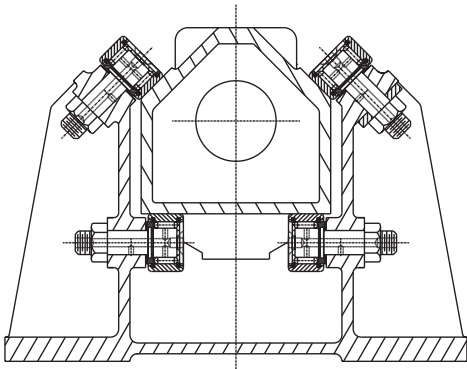

Ram Support Rollers

CAMROL® CF-S Series bearings guide and support the ram on resistance electric welder head. Elimination of costly scraped and gibbed ways with reduced power cylinder requirements are accomplished with these bearings.

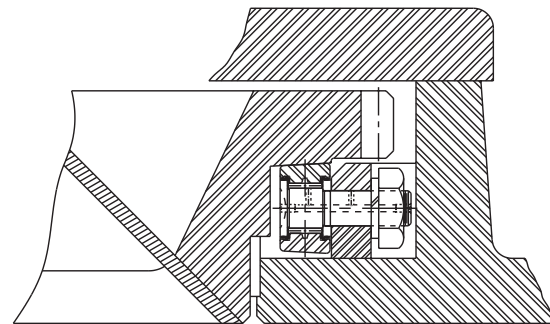

Rotary Table Support Follower

Special tapered outer race CF-Series CAMROL® bearings support a high speed gear driven circular table on textile machinery. These sealed bearings retain lubricant and resist the entry of fine material particles. They eliminate large and costly thrust type bearings, yet provide adequate friction free support.

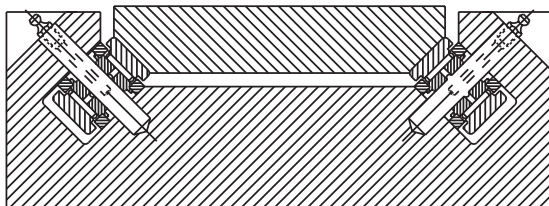

Platform Rollers

CAMROL® CYR Series bearings eliminate costly hand scraping of surfaces and eliminates sliding friction when applied as platform rollers.

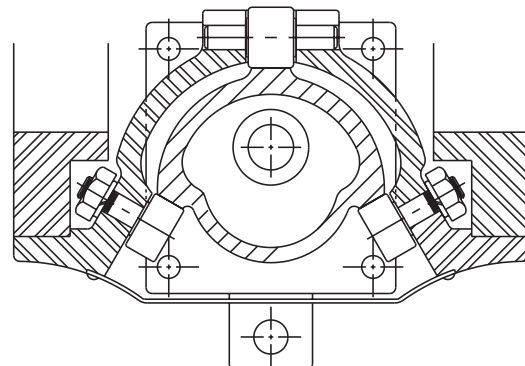

Linear Motion Guide Rollers

CAMROL® CF-S Series bearings offer support with three point mounting for the control of linear actuated guide roller applications. Use of the CAMROL® CYR Series bearing on eccentric pins provides adjustment for normal wear.

BEARING APPLICATIONS

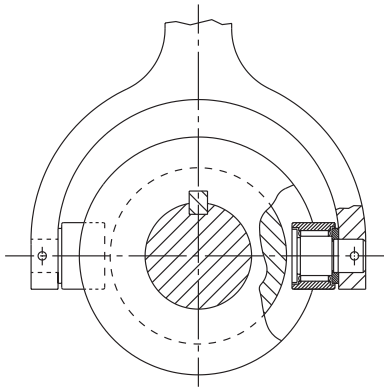

Shifting Fork Collar

Use of CF bearings in shifting fork collar mounting saves labor and costly machining. Operates smoothly and eliminates friction found in bronze collar types. Stud secures directly to fork fingers.

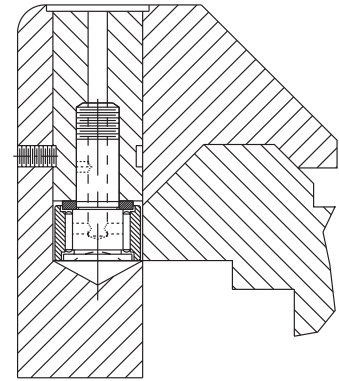

Turret Lathe Saddle

CAMROL® CF Series bearings applied as guide rollers on saddle way. Eliminates costly hand scraping and areas of sliding friction.

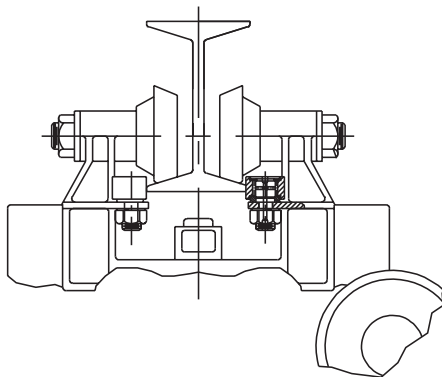

Side Guide Rollers

CAMROL® bearing rollers on overhead monorail hoists eliminate costly flanged wheels. Positive control of side shifting is maintained without excessive wear on track edges.

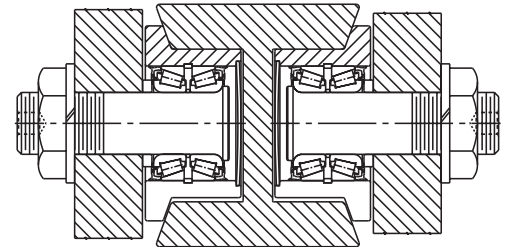

Transfer Rollers

Flanged FCF series TRAKROL® bearings used as transfer rollers. Integral stud and sealed roller bearing assembly are ideal anti-friction bearings for transfer machine application in areas of high contamination.

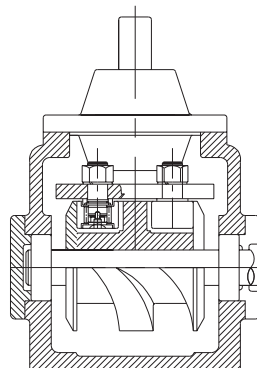

Precision Cam Actuated Index Unit

CFH Series CAMROL® bearings provide accurate control of station location in high speed indexing mechanism. These heavy stud followers provide minimum stud deflection at maximum loads with indexing speeds up to 1,000/min.

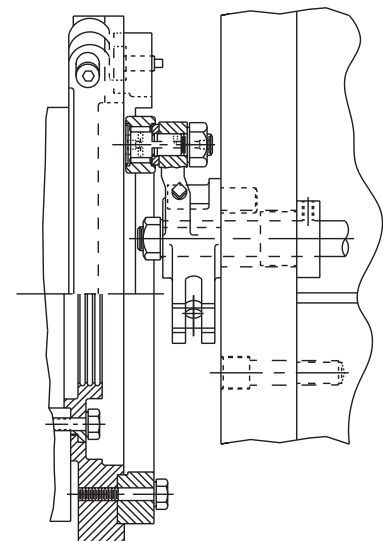

Gripper Cam on Printing Press

CF bearings replace friction rollers on gripper cams, sustain high shock loads of abrupt cam rise and segmented cam surfaces.

CF & CFH SERIES

BEARING APPLICATIONS

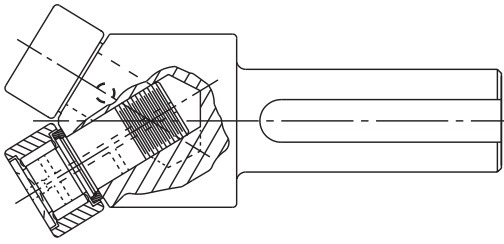

Burnishing Tool

CFH Series CAMROL® bearings are well adapted for use as precision and friction free burnishing rolls. Accurately ground roller surfaces provide excellent results in burnished finishes. Heavy section stud resists bending loads.

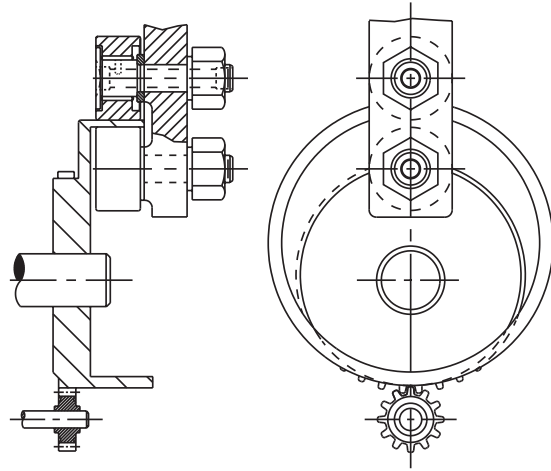

Hollow Cams

CAMROL® CFH Series cam followers are designed with flanged end of the stud flush with the face of the roller, enabling them to be used in bottom of grooves on cams of this type. Lubrication in such applications is provided through the stud from the threaded end or through the lever arm to which the follower is bolted.

OPTIONAL FEATURES — APPLICATIONS

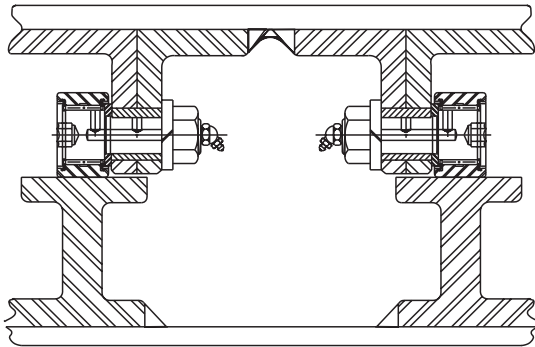

Eccentric Stud CAMROL® Bearing

Application: Slab conveyor

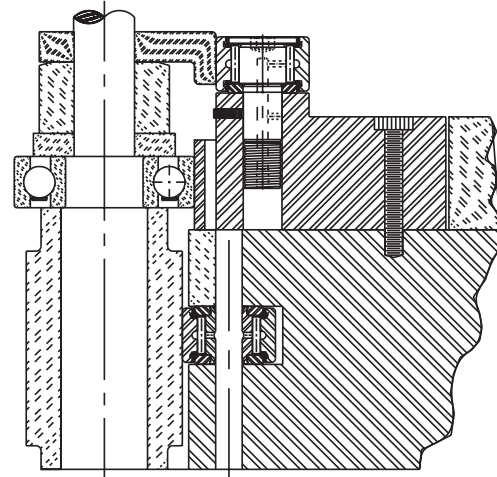

Hex Hole CAMROL® Bearing

Application: Slide feed mechanism for punch press

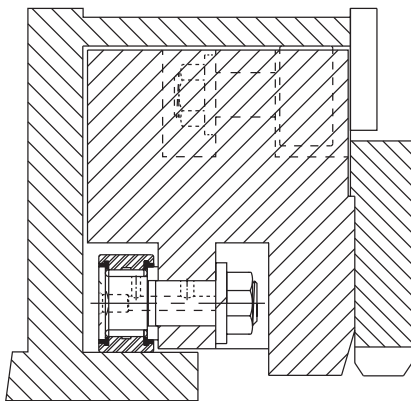

CAMROL® Bearing with LUBRI-DISC® seals

Application: Pipe beveling machine

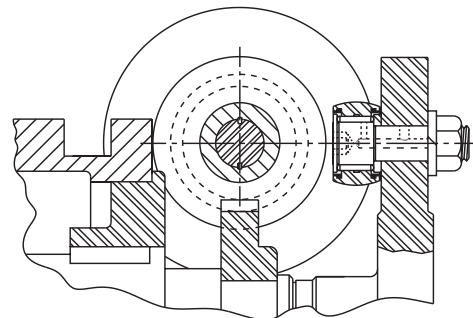

Crowned O.D. CAMROL® Bearing

Application: Canning machine track roller

Unsealed cam follower bearings

* TORRINGTON®		RBC		McGILL	
STD. STUD UNSEALED	HEAVY STUD UNSEALED	STD. STUD UNSEALED	HEAVY STUD UNSEALED	STD. STUD UNSEALED	HEAVY STUD UNSEALED
CR-8 CR-8-1	CRH-8-1	S-16 S-18	H-16 H-18	CF-1/2-N CF-1/2 CF-9/16	CFH-1/2 CFH-9/16
CR-10 CR-10-1	CRH-10-1	S-20	H-20	CF-5/8-N CF-5/8	CFH-5/8
CR-12 CR-14 CR-16 CR-18	CRH-12 CRH-14 CRH-16 CRH-18	S-22 S-24 S-28 S-32 S-36	H-22 H-24 H-28 H-32 H-36	CF-11/16 CF-3/4 CF-7/8 CF-1 CF-1 1/8	CFH-11/16 CFH-3/4 CFH-7/8 CFH-1 CFH-1 1/8
CR-20 CR-22 CR-24 CR-26 CR-28	CRH-20 CRH-22 CRH-24 CRH-26 CRH-28	S-40 S-44 S-48 S-52 S-56	H-40 H-44 H-48 H-52 H-56	CF-1 1/4 CF-1 3/8 CF-1 1/2 CF-1 5/8 CF-1 3/4	CFH-1 1/4 CFH-1 3/8 CFH-1 1/2 CFH-1 5/8 CFH-1 3/4
CR-30 CR-32 CR-36 CR-40 CR-44	CRH-30 CRH-32 CRH-36 CRH-40 CRH-44	S-60 S-64 S-72 S-80 S-88	H-60 H-64 H-72 H-80 H-88	CF-1 7/8 CF-2 CF-2 1/4 CF-2 1/2 CF-2 3/4	CFH-1 7/8 CFH-2 CFH-2 1/4 CFH-2 1/2 CFH-2 3/4
CR-48 CR-52 CR-56 CR-64	CRH-48 CRH-52 CRH-56 CRH-64	S-96 S-104 S-112 S-128	H-96 H-104 H-112 H-128	CF-3 CF-3 1/4 CF-3 1/2 CF-4	CFH-3 CFH-3 1/4 CFH-3 1/2 CFH-4

CAMROL® Bearings

* SMITH®				* INA®		McGILL	
OLD STD. STUD UNSEALED	NEW STD. STUD UNSEALED	OLD HEAVY STUD UNSEALED	NEW HEAVY STUD UNSEALED	STD. STUD UNSEALED	HEAVY STUD UNSEALED	STD. STUD UNSEALED	HEAVY STUD UNSEALED
CTA-1-A CTA-3 CTA-5 CTA-9-A CTA-13	CR-1/2-A CR-1/2 CR-9/16 CR-5/8-A CR-5/8	HCS-3 HCS-13	HR-1/2 HR-5/8	CF-8-1 CF-10-1	NA NA NA NA NA	CF-1/2-N CF-1/2 CF-9/16 CF-5/8-N CF-5/8	CFH-1/2 CFH-9/16 CFH-5/8
CTA-15 CTA-21 CTA-27 CTA-31 CTA-35	CR-11/16 CR-3/4 CR-7/8 CR-1 CR-1 1/8	HCS-21 HCS-27 HCS-31 HCS-35	HR-3/4 HR-7/8 HR-1 HR-1 1/8	CF-12 CF-14 CF-16 CF-18	NA NA NA NA NA	CF-11/16 CF-3/4 CF-7/8 CF-1 CF-1 1/8	CFH-11/16 CFH-3/4 CFH-7/8 CFH-1 CFH-1 1/8
CTA-45 CTA-47 CTA-51 CTA-57 CTA-65	CR-1 1/4 CR-1 3/8 CR-1 1/2 CR-1 5/8 CR-1 3/4	HCS-45 HCS-47 HCS-51 HCS-57 HCS-65	HR-1 1/4 HR-1 3/8 HR-1 1/2 HR-1 5/8 HR-1 3/4	CF-20 CF-22 CF-24 CF-26 CF-28	NA NA NA NA NA	CF-1 1/4 CF-1 3/8 CF-1 1/2 CF-1 5/8 CF-1 3/4	CFH-1 1/4 CFH-1 3/8 CFH-1 1/2 CFH-1 5/8 CFH-1 3/4
CTA-69 CTA-75 CTA-79 CTA-85 CTA-93	CR-1 7/8 CR-2 CR-2 1/4 CR-2 1/2 CR-2 3/4	HCS-69 HCS-75 HCS-79 HCS-85 HCS-93	HR-1 7/8 HR-2 HR-2 1/4 HR-2 1/2 HR-2 3/4	CF-30 CF-32 CF-36 CF-40 CF-44	NA NA NA NA NA	CF-1 7/8 CF-2 CF-2 1/4 CF-2 1/2 CF-2 3/4	CFH-1 7/8 CFH-2 CFH-2 1/4 CFH-2 1/2 CFH-2 3/4
CTA-101 CTA-109 CTA-117 CTA-125	CR-3 CR-3 1/4 CR-3 1/2 CR-4	HCS-101 HCS-109 HCS-117 HCS-125	HR-3 HR-3 1/4 HR-3 1/2 HR-4	CF-48 CF-52 CF-56 CF-64	NA NA NA NA	CF-3 CF-3 1/4 CF-3 1/2 CF-4	CFH-3 CFH-3 1/4 CFH-3 1/2 CFH-4

NA = Not Available

Coding for other cam follower types

OPTIONAL FEATURE	McGILL	* TORRINGTON®	RBC	* SMITH®	* INA®
Hex Hole	Add Suffix "B"	Add Prefix "B"	Add Suffix "W"	Add Suffix "B"	Add Suffix "SK"
Eccentric Stud	Add Prefix "E"	Add Prefix "E"	Add Suffix "X"	Add Suffix "E"	Add Prefix "E"
Crowned O.D.	Add Prefix "C"	Add Prefix "C"	Add Prefix "C"	Add Suffix "C"	Add Suffix "Y"
LUBRI-DISC® Seal	Add Suffix "S"	Add Prefix "S"	Add Suffix "L"	-	-

* The trademark TORRINGTON is a registered trademark of The Torrington Company.
 The trademark SMITH is a registered trademark of Accurate Bushing Co., Inc.
 The trademark INA is a registered trademark of Industriewerk Schaeffler, O. H. G.

INTERCHANGEABILITY CHART

Sealed cam follower bearings

* TORRINGTON®		RBC		McGILL	
STD. STUD SEALED	HEAVY STUD SEALED	STD. STUD SEALED	HEAVY STUD SEALED	STD. STUD SEALED	HEAVY STUD SEALED
CRS-8 CRS-8-1	CRHS-8-1	S-16-L S-18-L	H-16-L H-18-L	CF-1/2-N-S CF-1/2-S CF-9/16-S	CFH-1/2-S CFH-9/16-S
CRS-10 CRS-10-1	CRHS-10-1	S-20-L S-22-L	H-20-L H-22-L	CF-5/8-N-S CF-5/8-S CF-11/16-S	CFH-5/8-S
CRS-12 CRS-14 CRS-16 CRS-18 CRS-20	CRHS-12 CRHS-14 CRHS-16 CRHS-18 CRHS-20	S-24-L S-28-L S-32-L S-36-L S-40-L	H-24-L H-28-L H-32-L H-36-L H-40-L	CF-3/4-S CF-7/8-S CF-1-S CF-1 1/8-S CF-1 1/4-S	CFH-3/4-S CFH-7/8-S CFH-1-S CFH-1 1/8-S CFH-1 1/4-S
CRS-22 CRS-24 CRS-26 CRS-28 CRS-30	CRHS-22 CRHS-24 CRHS-26 CRHS-28 CRHS-30	S-44-L S-48-L S-52-L S-56-L S-60-L	H-44-L H-48-L H-52-L H-56-L H-60-L	CF-1 3/8-S CF-1 1/2-S CF-1 5/8-S CF-1 3/4-S CF-1 7/8-S	CFH-1 3/8-S CFH-1 1/2-S CFH-1 5/8-S CFH-1 3/4-S CFH-1 7/8-S
CRS-32 CRS-36 CRS-40 CRS-44 CRS-48	CRHS-32 CRHS-36 CRHS-40 CRHS-44 CRHS-48	S-64-L S-72-L S-80-L S-88-L S-96-L	H-64-L H-72-L H-80-L H-88-L H-96-L	CF-2-S CF-2 1/4-S CF-2 1/2-S CF-2 3/4-S CF-3-S	CFH-2-S CFH-2 1/4-S CFH-2 1/2-S CFH-2 3/4-S CFH-3-S
CRS-52 CRS-56 CRS-64 CRSB-80 CRSB-96 CRSB-112	CRHS-52 CRHS-56 CRHS-64 CRHSB-80 CRHSB-96 CRHSP-112	S-104-L S-112-L S-128-L S-160-LW S-192-LW	H-104-L H-112-L H-128-L H-160-LW H-192-LW	CF-3 1/4-S CF-3 1/2-S CF-4-S CF-5-S CF-6-S CF-7-S CF-8-S CF-9-S CF-10-S	CFH-3 1/4-S CFH-3 1/2-S CFH-4-S CFH-5-S CFH-6-S CFH-7-S

* SMITH®				* INA®		McGILL	
OLD STD. STUD SEALED	NEW STD. STUD SEALED	OLD HEAVY STUD SEALED	NEW HEAVY STUD SEALED	STD. STUD SEALED	HEAVY STUD SEALED	STD. STUD SEALED	HEAVY STUD SEALED
CTA-1-AX CTA-3X CTA-5X CTA-9-AX CTA-13X CTA-15X	CR-1/2-AX CR-1/2X CR-9/16X CR-5/8-AX CR-5/8X CR-11/16X	HCS-3X HCS-13X	HR-1/2X HR-5/8X	CF-8-1-PP CF-10-1-PP	NA NA NA NA NA	CF-1/2-N-S CF-1/2-S CF-9/16-S CF-5/8-N-S CF-5/8-S CF-11/16-S	CFH-1/2-S CFH-9/16-S CFH-5/8-S
CTA-21X CTA-27X CTA-31X CTA-35X CTA-45X	CR-3/4X CR-7/8X CR-1X CR-1 1/8X CR-1 1/4X	HCS-21X HCS-27X HCS-31X HCS-35X HCS-45X	HR-3/4X HR-7/8X HR-1X HR-1 1/8X HR-1 1/4X	CF-12-PP CF-14-PP CF-16-PP CF-18-PP CF-20-PP	NA NA NA NA NA	CF-3/4-S CF-7/8-S CF-1-S CF-1 1/8-S CF-1 1/4-S	CFH-3/4-S CFH-7/8-S CFH-1-S CFH-1 1/8-S CFH-1 1/4-S
CTA-47X CTA-51X CTA-57X CTA-65X CTA-69X	CR-1 3/8X CR-1 1/2X CR-1 5/8X CR-1 3/4X CR-1 7/8X	HCS-47X HCS-51X HCS-57X HCS-65X HCS-69X	HR-1 3/8X HR-1 1/2X HR-1 5/8X HR-1 3/4X HR-1 7/8X	CF-22-PP CF-24-PP CF-26-PP CF-28-PP CF-30-PP	NA NA NA NA NA	CF-1 3/8-S CF-1 1/2-S CF-1 5/8-S CF-1 3/4-S CF-1 7/8-S	CFH-1 3/8-S CFH-1 1/2-S CFH-1 5/8-S CFH-1 3/4-S CFH-1 7/8-S
CTA-75X CTA-79X CTA-85X CTA-93X CTA-101X	CR-2X CR-2 1/4X CR-2 1/2X CR-2 3/4X CR-3X	HCS-75X HCS-79X HCS-85X HCS-93X HCS-101X	HR-2X HR-2 1/4X HR-2 1/2X HR-2 3/4X HR-3X	CF-32-PP CF-36-PP CF-40-PP CF-44-PP CF-48-PP	NA NA NA NA NA	CF-2-S CF-2 1/4-S CF-2 1/2-S CF-2 3/4-S CF-3-S	CFH-2-S CFH-2 1/4-S CFH-2 1/2-S CFH-2 3/4-S CFH-3-S
CTA-109X CTA-117X CTA-125X CTA-137X	CR-3 1/4X CR-3 1/2X CR-4X CR-5XB CF-6XB	HCS-109X HCS-117X HCS-125X	HR-3 1/4X HR-3 1/2X HR-4X	CF-52-PP CF-56-PP CF-64-PP	NA NA NA NA NA	CF-3 1/4-S CF-3 1/2-S CF-4-S CF-5-S CF-6-S	CFH-3 1/4-S CFH-3 1/2-S CFH-4-S CFH-5-S CFH-6-S
						CF-7-S CF-8-S CF-9-S CF-10-S	CFH-7-S

NA = Not Available

Unsealed and sealed cam yoke roller bearings

*TORRINGTON®		RBC		McGILL	
UNSEALED	SEALED	UNSEALED	SEALED	UNSEALED	SEALED
YCR-12	YCRS-12	Y-24	Y-24-L	CYR-3/4	CYR-3/4-S
YCR-14	YCRS-14	Y-28	Y-28-L	CYR-7/8	CYR-7/8-S
YCR-16	YCRS-16	Y-32	Y-32-L	CYR-1	CYR-1-S
YCR-18	YCRS-18	Y-36	Y-36-L	CYR-1 1/8	CYR-1 1/8-S
YCR-20	YCRS-20	Y-40	Y-40-L	CYR-1 1/4	CYR-1 1/4-S
YCR-22	YCRS-22	Y-44	Y-44-L	CYR-1 3/8	CYR-1 3/8-S
YCR-24	YCRS-24	Y-48	Y-48-L	CYR-1 1/2	CYR-1 1/2-S
YCR-26	YCRS-26	Y-52	Y-52-L	CYR-1 5/8	CYR-1 5/8-S
YCR-28	YCRS-28	Y-56	Y-56-L	CYR-1 3/4	CYR-1 3/4-S
YCR-30	YCRS-30	Y-60	Y-60-L	CYR-1 7/8	CYR-1 7/8-S
YCR-32	YCRS-32	Y-64	Y-64-L	CYR-2	CYR-2-S
YCR-36	YCRS-36	Y-72	Y-72-L	CYR-2 1/4	CYR-2 1/4-S
YCR-40	YCRS-40	Y-80	Y-80-L	CYR-2 1/2	CYR-2 1/2-S
YCR-44	YCRS-44	Y-88	Y-88-L	CYR-2 3/4	CYR-2 3/4-S
YCR-48	YCRS-48	Y-96	Y-96-L	CYR-3	CYR-3-S
YCR-52	YCRS-52	Y-104	Y-104-L	CYR-3 1/4	CYR-3 1/4-S
YCR-56	YCRS-56	Y-112	Y-112-L	CYR-3 1/2	CYR-3 1/2-S
YCR-64	YCRS-64	Y-128	Y-128-L	CYR-4	CYR-4-S
	YCRS-80	Y-160	Y-160-L		CYR-5-S
	YCRS-96	Y-192	Y-192-L		CYR-6-S
	YCRS-112	Y-224	Y-224-L		CYR-7-S
					CYR-8-S
					CYR-9-S
					CYR-10-S

CAMROL® Bearings

* SMITH®				* INA®		McGILL	
OLD UNSEALED	NEW UNSEALED	OLD SEALED	NEW SEALED	UNSEALED	SEALED	UNSEALED	SEALED
CTY-21	YR-3/4	CTY-21X	YR-3/4X	RF-12	RF-12-PP	CYR-3/4	CYR-3/4-S
CTY-27	YR-7/8	CTY-27X	YR-7/8X	RF-14	RF-14-PP	CYR-7/8	CYR-7/8-S
CTY-31	YR-1	CTY-31X	YR-1X	RF-16	RF-16-PP	CYR-1	CYR-1-S
CTY-35	YR-1 1/8	CTY-35X	YR-1 1/8X	RF-18	RF-18-PP	CYR-1 1/8	CYR-1 1/8-S
CTY-45	YR-1 1/4	CTY-45X	YR-1 1/4X	RF-20	RF-20-PP	CYR-1 1/4	CYR-1 1/4-S
CTY-47	YR-1 3/8	CTY-47X	YR-1 3/8X	RF-22	RF-22-PP	CYR-1 3/8	CYR-1 3/8-S
CTY-51	YR-1 1/2	CTY-51X	YR-1 1/2X	RF-24	RF-24-PP	CYR-1 1/2	CYR-1 1/2-S
CTY-57	YR-1 5/8	CTY-57X	YR-1 5/8X	RF-26	RF-26-PP	CYR-1 5/8	CYR-1 5/8-S
CTY-65	YR-1 3/4	CTY-65X	YR-1 3/4X	RF-28	RF-28-PP	CYR-1 3/4	CYR-1 3/4-S
CTY-69	YR-1 7/8	CTY-69X	YR-1 7/8X	RF-30	RF-30-PP	CYR-1 7/8	CYR-1 7/8-S
CTY-75	YR-2	CTY-75X	YR-2X	RF-32	RF-32-PP	CYR-2	CYR-2-S
CTY-79	YR-2 1/4	CTY-79X	YR-2 1/4X	RF-36	RF-36-PP	CYR-2 1/4	CYR-2 1/4-S
CTY-85	YR-2 1/2	CTY-85X	YR-2 1/2X	RF-40	RF-40-PP	CYR-2 1/2	CYR-2 1/2-S
CTY-93	YR-2 3/4	CTY-93X	YR-2 3/4X	RF-44	RF-44-PP	CYR-2 3/4	CYR-2 3/4-S
CTY-101	YR-3	CTY-101X	YR-3X	RF-48	RF-48-PP	CYR-3	CYR-3-S
CTY-109	YR-3 1/4	CTY-109X	YR-3 1/4X	RF-52	RF-52-PP	CYR-3 1/4	CYR-3 1/4-S
CTY-117	YR-3 1/2	CTY-117X	YR-3 1/2X	RF-56	RF-56-PP	CYR-3 1/2	CYR-3 1/2-S
CTY-125	YR-4	CTY-125X	YR-4X	RF-64	RF-64-PP	CYR-4	CYR-4-S
		CTY-137X	YR-5X				CYR-5-S
			YR-6X				CYR-6-S
							CYR-7-S
							CYR-8-S
							CYR-9-S
							CYR-10-S

* The trademark TORRINGTON is a registered trademark of The Torrington Company.
 The trademark SMITH is a registered trademark of Accurate Bushing Co., Inc.
 The trademark INA is a registered trademark of Industriewerk Schaeffler, O. H. G.

MCGILL®

METRIC CAM FOLLOWERS

AVAILABLE IN EUROPEAN AND ASIAN VERSIONS — YOKE AND STUD TYPES

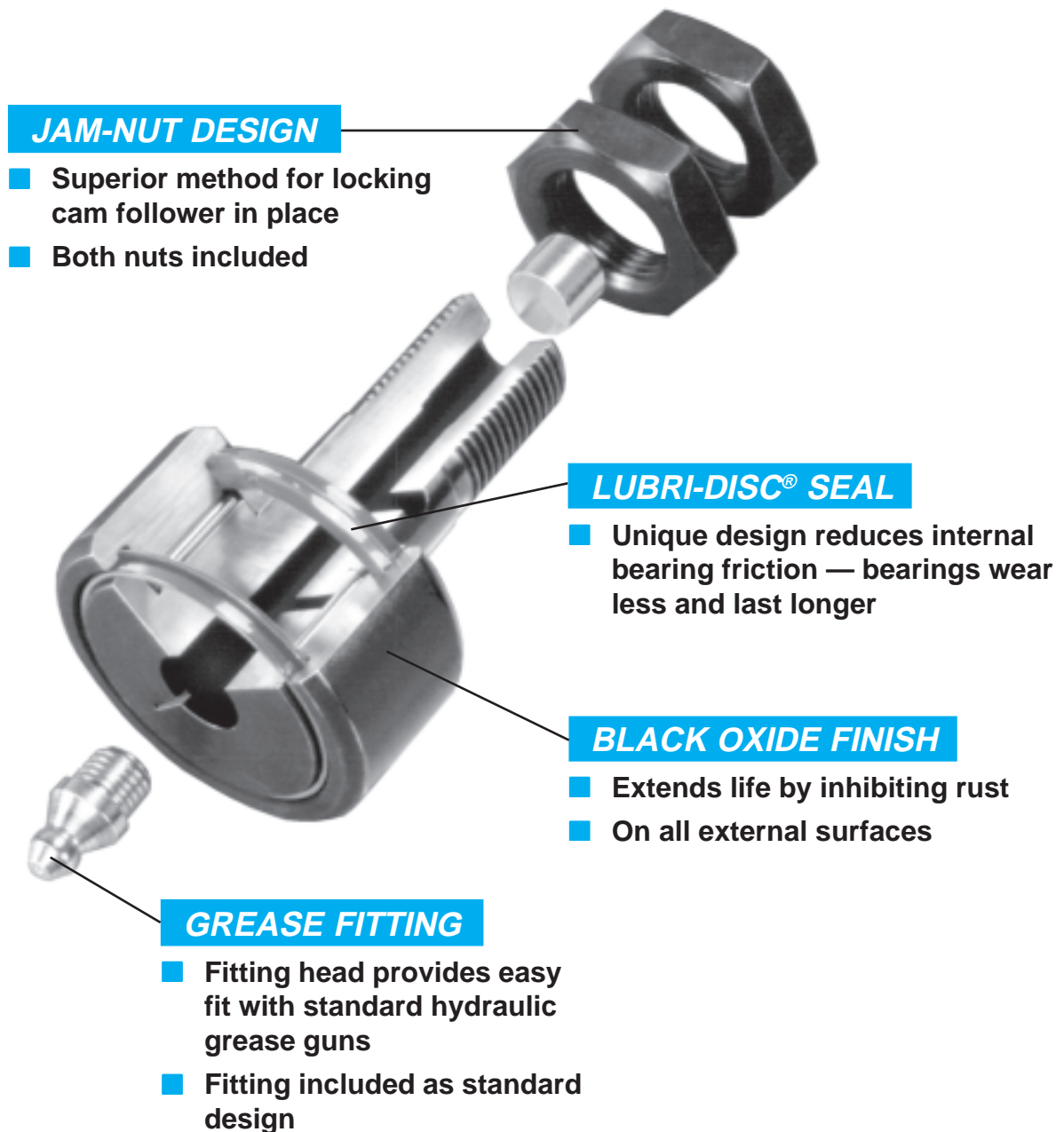

JAM-NUT DESIGN

- Superior method for locking cam follower in place
- Both nuts included

LUBRI-DISC® SEAL

- Unique design reduces internal bearing friction — bearings wear less and last longer

BLACK OXIDE FINISH

- Extends life by inhibiting rust
- On all external surfaces

GREASE FITTING

- Fitting head provides easy fit with standard hydraulic grease guns
- Fitting included as standard design

CAMROL® — the original cam follower bearing, invented by McGill over 50 years ago

CAMROL® is the trademark for the line of roller bearing cam followers manufactured by McGill and designed for use as cam followers and track rollers. The CAMROL® cam follower bearing was originally invented by McGill over 50 years ago. Since then, McGill has maintained its leading position through the continuous development of new features and improvements to the line.

McGill has worked closely with our customers to serve global needs of industry with a complete series of METRIC cam followers. The McGill standard metric CAMROL® bearing is manufactured to ISO standards and Asian designs. The metric stud type MCF® and cam yoke roller MCYR® bearings share all the same features and range of options as other CAMROL® bearings. Each Cam Follower is supplied with two nuts and appropriate metric threads; the second nut is intended to serve as a locknut. All designs use the patented LUBRI-DISC® seals that provide protection against contamination and loss of lubricant. LUBRI-DISC® seals reduce internal bearing friction — bearings wear less and last longer.

Also available are the CAMROL® bearing series MCFD® and MCYRD® Metric bearings, which provide greater basic dynamic load ratings by utilizing cylindrical rollers in place of standard needle rollers. This construction allows the bearings to take heavier axial loading.

ENGINEERING DATA

Construction

McGill offers CAMROL® bearings in metric dimensions equivalent to the ISO standard series. Construction features include...

- Outer rings with a large radial cross section to withstand bending stresses that result from heavy rolling or shock loads.
- Integral inner studs on MCF® and MCFR® cam followers are designed for cantilever mounting. Extended end of the inner stud is threaded; screwdriver slot on flange end holds the stud stationary while tightening the nut during mounting.
- Two nuts with metric threads. The second nut serves as a locknut.
- Cam yoke roller bearings are designed to mount on a shaft in a yoke support arrangement.
- Black oxide finish on all exposed surfaces for maximum corrosion resistance.
- All bearings also available with a cylindrical outside diameter instead of the standard 500mm crown radius.
- Lubri-Disc® Seal provides protection against contaminants and loss of lubricant, reduces internal bearing friction — increases bearing life and improves performance.
 - Lip-type, molydisulfide-filled nylon seals provide a combination of sealing effects including contact, labyrinth and grease dam sealing, and provide superior wear and friction properties.
 - Resulting lower operating temperatures substantially reduce relubrication requirements and permit higher operating speeds.
 - Continuous operating temperature capability of -29°C to +121°C.
- Needle bearing cam followers also available with heat-treated cages that accurately guide the rollers for enhanced performance. The cages allow a larger quantity of lubricant. The cages are designed with two rollers per pockets (except 13, 16 and 19mm OD's) to obtain the ultimate in static and dynamic load ratings, yet still offer the advantages of a caged construction.
- Stud type needle bearing cam followers are also available with hexagonal hole in the face of the stud in place of the screwdriver slot - and are also available with an eccentric collar on the stud to provide easy radial adjustment of the bearings.
- Yoke type needle bearing cam followers are now available with the endplates secured by liquid metal injection. Provides up to 10 times the holding force on the endplate, improved roundness of the assembled bearing and significantly less assembled stress of the inner ring.

Load ratings

The Basic Load Rating or Basic Dynamic Rating, as defined by ABMA and ISO, is that calculated, constant radial load which 90% of a group of apparently identical bearings with stationary outer ring can theoretically endure for a rating life of 1,000,000 revolutions (33 1/3 rpm for 500 hours). The Basic Load Rating is a reference value only, the base value of 1,000,000 revolutions chosen for ease of calculation.

The dimensional tables list the Basic Dynamic (C) and Basic Static (Co) Load Ratings as calculated by the ISO and AFBMA Standards. Also listed are the Dynamic and Static Ratings for the CAMROL bearings operating as track rollers. These dynamic and static ratings are less than those calculated by the basic load rating formulas (C and Co) and account for the additional bending stresses present because the outer ring is unsupported. The load applied on the bearing while it is operating dynamically should not exceed 50% of the Dynamic Rating as a Track Roller. Applications involving reversing radial loads on stud type bearings should be reviewed by the McGill Engineering Department.

Bearing life

Statistical L₁₀ bearing fatigue life can be calculated according to the following formula:

$$L_{10} \text{ Life in Hours} = \frac{16666}{N} \times \left(\frac{BDR}{P} \right)^{10/3}$$

Where:

- BDR = Basic Dynamic Rating (Newtons)
- P = Radial Load (Newtons)

- N = Speed (RPM)
- L₁₀ = Fatigue Life (Hours)

To determine the Basic Dynamic Rating required for a given application, use the following formula:

$$BDR = .054 \times P \times (L_{10} \times N)^{.3}$$

Mounting

The following should be considered in mounting CAMROL® bearings:

- The housing that supports the cam follower stud (or the shaft on which the cam yoke roller is mounted) should be of sufficient strength to resist excessive deformation and bending under the expected applied load.
- The face of the housing should be flat and square with the housing bore, and must have a diameter of at least that listed in the dimensional tables for proper support of the bearing endplate.
- In order to obtain the best support for the CAMROL® bearing, the chamfer on the housing bore should not exceed 0.5 mm x 45°.

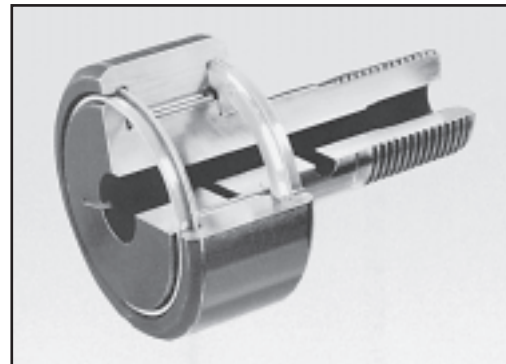

Stud Type

- When mounting Stud Type CAMROL® bearings in a machine member, the radial lubrication hole (it is in line with the McGill name) should be located in the unloaded portion of the raceway.
- Any pressure required for installation should be applied against the solid center portion of the flanged inner stud (not on the flange perimeter), and the cam follower should be drawn up tightly by the nut so the bearing endplate is securely backed up.
- Precaution should be taken to avoid excessive torque when tightening the clamping nut; otherwise undue stress may be set up in the stud.
- The clamping nut should not be tightened beyond the maximum clamping torque listed in the dimensional table.

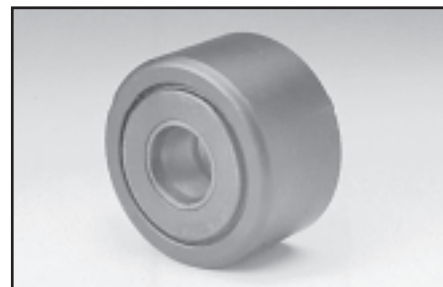

Yoke Type

- Yoke Type CAMROL® bearings should be mounted with the lubrication hole in the unloaded portion of the raceway and according to the recommended shaft dimensions listed in the tabular data.
- When a tight fit of the bearing on a shaft is desired, an ISO j6 shaft tolerance should be employed.
- For heavily loaded applications, the bearing should be clamped endwise and mounted on a high strength shaft with an ISO j6 tolerance.
- If the bearing cannot be clamped endwise, it is essential to have a close axial fit in the yoke in which the bearing is mounted to prevent axial displacement of the endplates under load.

Lubrication

All CAMROL® bearings from McGill are supplied prelubricated with a high grade lithium base grease having an operating temperature range of -29°C to +120°C (-20°F to +248°F) and frequent relubrication is suggested for continuous rotating applications.

Provision for relubrication - stud type

Stud type CAMROL® bearings have provision for relubrication either through the end of the inner stud or through a cross drilled hole in the stud shank.

Sizes up through 19mm OD do not have an axial hole from the threaded end, and no cross drill hole is present in the stud shank on sizes through 26mm OD. The counterbored ends of the axial holes are designed to accept a press-fitted type metric lubrication fitting. Closing plugs are supplied so that the unused axial hole or holes can be sealed. If the cross drilled hole is not used for relubrication, it should be covered by the housing; therefore, no plug is supplied for this hole.

Provision for relubrication - yoke type

Yoke Type CAMROL® bearings have a lubrication hole in the inner ring bore so relubrication can be accomplished through a cross-drilled hole in the supporting shaft if desired.

Track design

Since cam followers or cam yoke rollers are merely one component of a two-piece bearing construction, along with the track or cam on which it operates, proper selection of the track or cam material must be considered. This selection has a direct effect upon ultimate life and performance of the cam roll application.

Where bearings are used as support or guide rollers, it is often difficult to obtain high hardness and tensile strength values for the machine members against which the bearings operate. In the interest of economy, relatively soft structural materials can be applied in most applications where dimensional accuracy is not extremely critical. The work hardening of ferrous, low carbon track materials, accompanied by relatively small amounts of wear-in of the bearing into the track surface, generally results in satisfactory bearing performance. In the application of cam follower or cam yoke roller bearings (lift truck mast rollers, for instance), it is common to employ formed structural steel sections as bearing track support members, and the wearing-in and work hardening of the track surface generally results in a satisfactory bearing application, providing loads are not excessive.

Cam design

Cam applications are similar in many respects to track or support roller applications, except that bearing speeds are higher due to the multiplication of cam revolutions per minute by the ratio of the cam OD to the cam follower OD. Because of these higher speeds, oil lubrication is preferred, but where such lubrication methods are not possible, grease should be replaced frequently.

In the application of box or drum cams, it is possible to obtain differential rotation of the cam follower outer race as well as associated load reversals. This may result in excessive wear of cams or cam followers unless proper cam hardness and materials are employed, as well as ample lubrication. In box cams of this nature, the cam rise and cam fall should be watched closely, since the load reversal encountered can cause shock loads in excess of the capacity of the stud or bearing.

The same precaution applies to ordinary circular cams. Instantaneous loads due to rapid cam rise should be carefully calculated and kept below the ultimate strength of the follower and the stud.

In ordinary cam design it is possible to employ the most efficient materials for best resistance to fatigue and brinelling, and attainment of high track surface hardnesses associated with good wear resistance is quite feasible. The same general precautions concerning tensile strength, as listed under track design above, should be followed for cam design; applications involving high marginal bearing or cam loading should be referred to the McGill Engineering Department.

Track capacity

Track capacity of all cam follower and cam yoke roller bearings is the load which a steel track of a given tensile strength will withstand continuously without deformation or brinelling. Table II lists track capacities for steel tracks for the standard crowned roller outside diameter versions. For the straight cylindrical roller outside diameter versions ("-X" suffix), multiply by 1.25 to obtain the track capacity ratings.

To obtain track capacities for track hardnesses other than Rockwell "C" scale 40 (tensile strength 1242 MPa), multiply track capacity by track capacity factor listed in Table I. Regardless of track capacity, dynamic load should not exceed 50% of basic dynamic rating as a track roller and static load should not exceed maximum static rating as a track roller.

Table I - Track Tensile Strength

MPa	TRACK HARDNESS ROCKWELL "C"	TRACK CAPACITY FACTOR
828	26	.445
966	32	.667
1104	36	.792
1242	40	1.000
1380	44	1.237
1518	47	1.495
1656	50	1.775
1794	53	2.090
1932	56	2.420
2070	58	2.780

Table II - Track Capacities

BASIC BEARING NUMBER	TRACK CAPACITY NEWTONS	BASIC BEARING NUMBER	TRACK CAPACITY NEWTONS
MCFR-13	1910	MCFR-52	19200
MCFR-16	2940	MCYRR-25	19200
MCYRR-5	2940	MCFD-52	19200
MCFR-19	3490	MCYRD-25	19200
MCYRR-6	3490	MCFR-62	28400
MCFR-22	4270	MCYRR-30	27400
MCYRR-8	5500	MCFD-62	28400
MCFR-26	5050	MCYRD-30	27400
MCFR-30	6350	MCFR-72	31800
MCYRR-10	6350	MCYRR-35	30500
MCFR-32	6780	MCFD-72	31800
MCYRR-12	6780	MCYRD-35	30500
MCFR-35	9840	MCFR-80	43800
MCYRR-15	9840	MCYRR-40	36700
MCFD-35	9840	MCFD-80	43800
MCYRD-15	9840	MCYRD-40	36700
MCFR-40	12000	MCFR-85	46400
MCYRR-17	12000	MCYRR-45	39000
MCFD-40	12000	MCYRD-45	39000
MCYRD-17	12000	MCFR-90	49200
MCFR-47	17400	MCYRR-50	41300
MCYRR-20	17400	MCFD-90	49200
MCFD-47	17400	MCYRD-50	41300
MCYRD-20	17400		

CAMROL® Bearings

ENGINEERING DATA

Hex hole



Metric stud type CAMROL® bearings are available with a hexagonal hole in the face of the stud in place of the screw driver slot. This feature is advantageous for mounting bearings in blind holes or with self-locking nuts requiring greater-than-average thread torque. In this modification, relubrication through the flange end of the stud is not possible.

Hexagonal wrench sizes

BASIC BEARING NUMBER	HEX WRENCH SIZE, MM	BASIC BEARING NUMBER	HEX WRENCH SIZE, MM
13	3	47	10
16	4	47A	10
19	4	52	10
22	4	52A	10
22A	5	62	14
26	4	62A	14
26A	5	72	14
30	6	72A	14
32	6	80	14
35	8	85	14
40	8	90	14
40A	8		

Eccentric collar



The eccentric collar feature provides an easy means of radial adjustment for positioning of cam followers, track, guide and support rollers.

In-line combinations of eccentric collar CAMROL® bearings can be aligned without the need for extremely close tolerances of mounting holes and members. Problems involving control of clearances, pre-loading and compensation for wear can be avoided or solved by the easy adjustment of new bearings.

In most applications, a locknut is sufficient to hold the bearing at the desired position. In applications where a more positive means of holding a given position is required, this can be accomplished by drilling and doweling through the housing into the bushing and the stud.

Coding for metric CAMROL® bearings



Stud type

SERIES	CONSTRUCTION FEATURES
MCF	Full complement of needle rollers
MCFE	With eccentric collar
MCF-X	With cylindrical outside diameter
MCF-B, MCF-BX	With hexagonal hole
MCF-S, MCF-SBX	With seals
MCFR	Caged needle rollers
MCFRE	With eccentric collar
MCFR-X	With cylindrical outside diameter
MCFR-B, MCFR-BX	With hexagonal hole
MCFR-S, MCFR-SBX	With seals
MCFD	Full complement cylindrical rollers
MCFDE	With eccentric collar
MCFD-X	With cylindrical outside diameter



Yoke type

SERIES	CONSTRUCTION FEATURES
MCYR	Full complement of needle rollers
MCYR-S	With seals
MCYR-X	With cylindrical outside diameter
MCYR-SX	With cylindrical outside diameter
MCYRR	Caged needle rollers
MCYRR-S	With seals
MCYRR-SX	With cylindrical outside diameter
MCYRD	Full complement cylindrical rollers
MCYRD-X	With cylindrical outside diameter

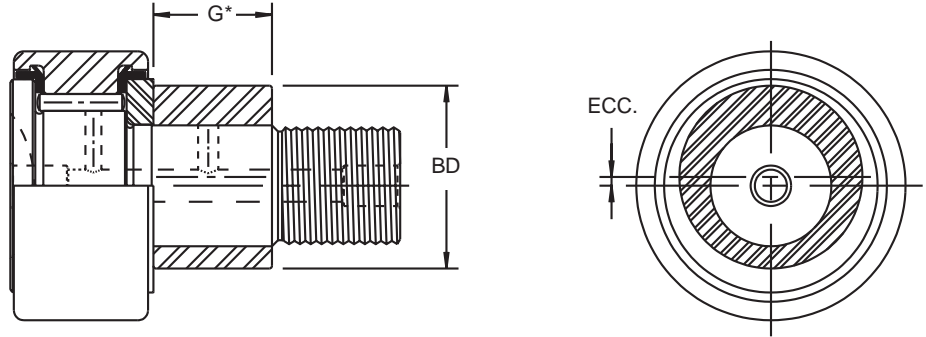

(For other dimensions refer to tabulated chart)

BASIC BEARING NUMBER	G*	BD		ECC. ECCENTRICITY	RECOMMENDED HOUSING BORE DIA.
	+0.05 -0.15	mm			+0.025 -0.000
	mm	MIN.	MAX.		mm
16	7	8.964	9.000	0.5	9.050
19	9	10.957	11.000	0.5	11.050
22	10	12.957	13.000	0.5	13.050
22A	10	12.957	13.000	0.5	13.050
26	10	12.957	13.000	0.5	13.050
26A	10	12.957	13.000	0.5	13.050
30	11	14.957	15.000	0.5	15.050
32	11	14.957	15.000	0.5	15.050
35	14	19.948	20.000	1.0	20.050
40	16	21.948	22.000	1.0	22.050
40A	16	21.948	22.000	1.0	22.050
47	18	23.948	24.000	1.0	24.050
47A	18	23.948	24.000	1.0	24.050
52	18	23.948	24.000	1.0	24.050
52A	18	23.948	24.000	1.0	24.050
62	22	27.948	28.000	1.0	28.050
62A	22	27.948	28.000	1.0	28.050
72	22	27.948	28.000	1.0	28.050
72A	22	27.948	28.000	1.0	28.050
80	29	34.938	35.000	1.5	35.050
85	29	34.938	35.000	1.5	35.050
90	29	34.938	35.000	1.5	35.050

*For positive clamping, housing thickness should be 0.3 mm greater than G dimension.

MCF® SERIES

STUD TYPE

- Series MCF® — Unsealed, full complement
- Series MCF-S — Sealed, full complement
- Series MCFR® — Unsealed, cage type
- Series MCFR-S — Sealed, cage type

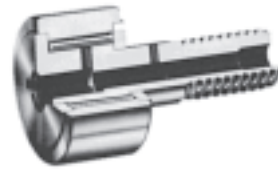

MCF®

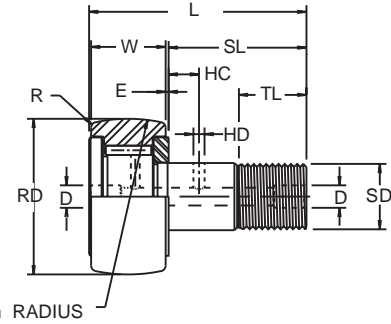

UNSEALED BRG. NO. (1)	SEALED BRG. NO. (1)	ROLLER DIA. RD NOM. (2)	ROLLER WIDTH W +0.00 -0.12	STUD DIA. SD NOM. (3)	STUD L'GTH. SL NOM.	OVERALL LENGTH L NOM.	ENDPLATE EXTENSION E NOM.	THREAD	THREAD LENGTH TL MIN.	OIL HOLE	
										(HC) NOM.	(HD) NOM.
		mm	mm	mm	mm	mm	mm	mm	mm	mm	
MCFR-13	MCFR-13-S	13	9	5	13	23	0.6	M5x0.8	7.5	-	-
MCFR-16	MCFR-16-S	16	11	6	16	28	0.6	M6x1	9	-	-
MCFR-19	MCFR-19-S	19	11	8	20	32	0.6	M8x1.25	11	-	-
MCFR-22	MCFR-22-S	22	12	10	23	36	0.6	M10x1	12	-	-
MCFR-22A	MCFR-22A-S	22	12	10	23	36	0.6	M10x1.25	13	-	-
MCFR-26	MCFR-26-S	26	12	10	23	36	0.6	M10x1	12	-	-
MCFR-26A	MCFR-26A-S	26	12	10	23	36	0.6	M10x1.25	13	-	-
MCFR-30	MCFR-30-S	30	14	12	25	40	0.6	M12x1.5	14	6	3
MCFR-32	MCFR-32-S	32	14	12	25	40	0.6	M12x1.5	14	6	3
MCFR-35	MCFR-35-S	35	18	16	32.5	52	0.8	M16x1.5	18	8	3
MCFR-40	MCFR-40-S	40	20	18	36.5	58	0.8	M18x1.5	19	8	3
MCFR-40A	MCFR-40A-S	40	20	18	36.5	58	0.8	M18x1.5	20	10	3
MCFR-47	MCFR-47-S	47	24	20	40.5	66	0.8	M20x1.5	21	9	4
MCFR-47A	MCFR-47A-S	47	24	20	40.5	66	0.8	M20x1.5	22	12	4
MCFR-52	MCFR-52-S	52	24	20	40.5	66	0.8	M20x1.5	21	9	4
MCFR-52A	MCFR-52A-S	52	24	20	40.5	66	0.8	M20x1.5	22	12	4
MCFR-62	MCFR-62-S	62	29	24	49.5	80	0.8	M24x1.5	25	11	4
MCFR-62A	MCFR-62A-S	62	29	24	49.5	80	0.8	M24x1.5	25	12	4
MCFR-72	MCFR-72-S	72	29	24	49.5	80	0.8	M24x1.5	25	11	4
MCFR-72A	MCFR-72A-S	72	29	24	49.5	80	0.8	M24x1.5	25	12	4
MCFR-80	MCFR-80-S	80	35	30	63	100	1	M30x1.5	32	15	4
MCFR-85	MCFR-85-S	85	35	30	63	100	1	M30x1.5	32	15	4
MCFR-90	MCFR-90-S	90	35	30	63	100	1	M30x1.5	32	15	4

(1) Standard bearing has a crowned roller outside diameter. For straight cylindrical outside roller diameter, add suffix "X". Example - MCFR-35-X or MCF-35-SX
 (2) Tolerance limits for Roller Diameter are shown below.

Cylindrical Roller Dia. "RD"

RD (NOM.)		TOLERANCE	
OVER	INCL.	MAX.	MIN.
mm	mm	mm	mm
6	18	0	-0.008
18	30	0	-0.009
30	50	0	-0.011
50	80	0	-0.013
80	120	0	-0.015

Crowned Roller Dia. "RD"

RD (NOM.)		TOLERANCE	
OVER	INCL.	MAX.	MIN.
mm	mm	mm	mm
6	120	0	-0.050



MCFR-S

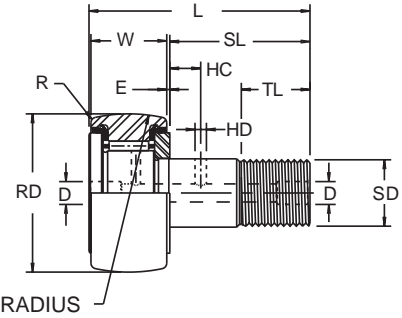

500mm RADIUS

UNSEALED BRG. NO. (1)	SEALED BRG. NO. (1)	REAMED HOLE D NOM.	CORNER RADIUS R	CLAMPING DIA. MIN.	CLAMPING TORQUE MAX (4)	LIMITING SPEED (7)		HOUSING BORE DIA.		ISO/ABMA BASIC LOAD RATINGS NEWTONS		TRACK ROLLER LOAD RATINGS NEWTONS		MASS
						GREASE	OIL	mm		DYNAMIC	STATIC	DYNAMIC	STATIC	
						rpm	rpm	MIN.	MAX.			(6)	(5)	
MCFR-13	MCFR-13-S	3.1*	0.3	9	2.2	20000	30000	5.000	5.012	2450	2260	2060	1650	0.010
MCFR-16	MCFR-16-S	4*	0.3	11	3	19500	25000	6.000	6.012	4120	4120	3430	2350	0.018
MCF-16	MCF-16-S					13000	17000			6960	8340	5790	2350	0.019
MCFR-19	MCFR-19-S	4*	0.3	13	8	15500	20000	8.000	8.015	4510	5000	3730	4140	0.028
MCF-19	MCF-19-S					10500	13500			8040	10490	6670	5100	0.029
MCFR-22	MCFR-22-S	4	0.5	15	15	13500	17500	10.000	10.015	6280	7260	5200	6050	0.043
MCF-22	MCF-22-S					9000	11500			9410	12360	7850	10400	0.044
MCFR-22A	MCFR-22A-S	4	0.5	15	15	13500	17500	10.000	10.015	6280	7260	5200	6050	0.043
MCF-22A	MCF-22A-S					9000	11500			9410	12360	7850	10400	0.044
MCFR-26	MCFR-26-S	4	0.5	15	15	13500	17500	10.000	10.015	6280	7260	5200	6050	0.055
MCF-26	MCF-26-S					9000	11500			9410	12360	7850	10400	0.056
MCFR-26A	MCFR-26A-S	4	0.5	15	15	13500	17500	10.000	10.015	6280	7260	5200	6050	0.055
MCF-26A	MCF-26A-S					9000	11500			9410	12360	7850	10400	0.056
MCFR-30	MCFR-30-S	6	1	19	22	9600	12500	12.000	12.018	8240	9710	6860	8050	0.087
MCF-30	MCF-30-S					6400	8300			13240	18140	11080	15300	0.089
MCFR-32	MCFR-32-S	6	1	19	22	9600	12500	12.000	12.018	8240	9710	6860	8050	0.096
MCF-32	MCF-32-S					6400	8300			13240	18140	11080	15300	0.099
MCFR-35	MCFR-35-S	6	1	24	57	6300	8000	16.000	16.018	13040	19030	10890	15900	0.166
MCF-35	MCF-35-S					4200	5500			20300	34130	16970	28500	0.171
MCFR-40	MCFR-40-S	6	1.5	27	85	5000	6400	18.000	18.018	15990	23730	13340	19800	0.245
MCF-40	MCF-40-S					3300	4300			23240	38540	19420	32200	0.248
MCFR-40A	MCFR-40A-S	6	1.5	27	85	5000	6400	18.000	18.018	15990	23730	13340	19800	0.245
MCF-40A	MCF-40A-S					3300	4300			23240	38540	19420	32200	0.248
MCFR-47	MCFR-47-S	8	1.5	30	118	3900	5000	20.000	20.021	21280	35700	17750	29800	0.387
MCF-47	MCF-47-S					2600	3400			30790	57670	25690	46700	0.393
MCFR-47A	MCFR-47A-S	8	1.5	30	118	3900	5000	20.000	20.021	21280	35700	17750	29800	0.387
MCF-47A	MCF-47A-S					2600	3400			30790	57670	25690	46700	0.393
MCFR-52	MCFR-52-S	8	1.5	30	118	3900	5000	20.000	20.021	21280	35700	17750	29800	0.453
MCF-52	MCF-52-S					2600	3400			30790	57670	25690	46700	0.455
MCFR-52A	MCFR-52A-S	8	1.5	30	118	3900	5000	20.000	20.021	21280	35700	17750	29800	0.453
MCF-52A	MCF-52A-S					2600	3400			30790	57670	25690	46700	0.455
MCFR-62	MCFR-62-S	8	1.5	38	216	3100	4100	24.000	24.021	31680	55700	26380	46300	0.801
MCF-62	MCF-62-S					2100	2700			46580	92630	38840	65400	0.810
MCFR-62A	MCFR-62A-S	8	1.5	38	216	3100	4100	24.000	24.021	31680	55700	26380	46300	0.801
MCF-62A	MCF-62A-S					2100	2700			46580	92680	38840	65400	0.810
MCFR-72	MCFR-72-S	8	2	38	216	3100	4100	24.000	24.021	31680	55700	26380	46300	1.039
MCF-72	MCF-72-S					2100	2700			46580	92680	38840	65400	1.048
MCFR-72A	MCFR-72A-S	8	2	38	216	3100	4100	24.000	24.021	31680	55700	26380	46300	1.039
MCF-72A	MCF-72A-S					2100	2700			46580	92680	38840	65400	1.048
MCFR-80	MCFR-80-S	8	2	51	441	2200	2900	30.000	30.021	56000	105030	46680	87600	1.621
MCF-80	MCF-80-S					1500	2000			76980	159850	64140	102300	1.642
MCFR-85	MCFR-85-S	8	2	51	441	2200	2900	30.000	30.021	56000	105030	46680	87600	1.793
MCF-85	MCF-85-S					1500	2000			76980	159850	64140	102300	1.814
MCFR-90	MCFR-90-S	8	2	51	441	2200	2900	30.000	30.021	56000	105030	46680	87600	1.981
MCF-90	MCF-90-S					1500	2000			76980	159850	64140	102300	2.002

(3) Stud Diameter "SD" per ISO tolerance h7, shown below.

Stud Dia. "SD"

SD (NOM.)		TOLERANCE	
OVER	INCL.	MAX.	MIN.
mm	mm	mm	mm
2	6	0	-0.012
6	10	0	-0.015
10	18	0	-0.018
18	30	0	-0.021

(4) Clamping torque is based on dry threads. If threads are lubricated, use half of value shown.

(5) Static load rating is based on stud strength or on internal rolling element load distribution stresses.

(6) Dynamic load should not exceed 50% of Dynamic Rating as a track roller.

(7) Since load, lubrication method, temperature and other factors affect the maximum operating speed, it is impossible to determine precise limiting speed. The listed limiting speeds are based on lightly loaded bearings having adequate lubrication and are listed only as a design guide. More frequent relubrication is required when operating at higher speeds. Actual bearing testing in the specific application should be conducted if the anticipated operating speed approaches the listed limiting speed.

• Sizes marked have no lube holes in threaded end of stud.

MCYR® SERIES

YOKE TYPE

- Series **MCYR®** — Unsealed, full complement
- Series **MCYR-S** — Sealed, full complement
- Series **MCYRR®** — Unsealed, cage type
- Series **MCYRR-S** — Sealed, cage type



MCYR®

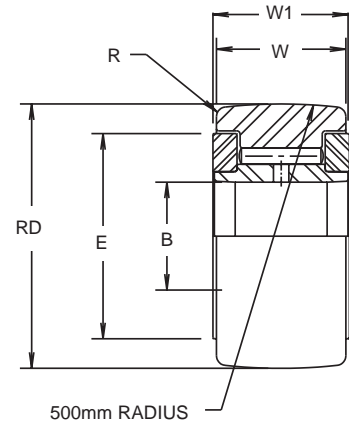

UNSEALED BEARING NUMBER (1)	SEALED BEARING NUMBER (1)	BEARING DIMENSIONS						
		BORE DIA. B		ROLLER DIA. RD NOM. (2)	ROLLER WIDTH W	WIDTH W1		CORNER RADIUS R
		MAX.	MIN.			MAX.	MIN.	
		mm	mm	mm	mm	mm	mm	mm
MCYRR-5 MCYR-5	MCYRR-5-S MCYR-5-S	5	4.992	16	11	12	11.82	0.3
MCYRR-6 MCYR-6	MCYRR-6-S MCYR-6-S	6	5.992	19	11	12	11.82	0.3
MCYRR-8 MCYR-8	MCYRR-8-S MCYR-8-S	8	7.992	24	14	15	14.82	0.5
MCYRR-10 MCYR-10	MCYRR-10-S MCYR-10-S	10	9.992	30	14	15	14.82	1
MCYRR-12 MCYR-12	MCYRR-12-S MCYR-12-S	12	11.992	32	14	15	14.82	1
MCYRR-15 MCYR-15	MCYRR-15-S MCYR-15-S	15	14.992	35	18	19	18.79	1
MCYRR-17 MCYR-17	MCYRR-17-S MCYR-17-S	17	16.992	40	20	21	20.79	1.5
MCYRR-20 MCYR-20	MCYRR-20-S MCYR-20-S	20	19.990	47	24	25	24.79	1.5
MCYRR-25 MCYR-25	MCYRR-25-S MCYR-25-S	25	24.990	52	24	25	24.79	1.5
MCYRR-30 MCYR-30	MCYRR-30-S MCYR-30-S	30	29.990	62	28	29	28.79	1.5
MCYRR-35 MCYR-35	MCYRR-35-S MCYR-35-S	35	34.988	72	28	29	28.79	2
MCYRR-40 MCYR-40	MCYRR-40-S MCYR-40-S	40	39.988	80	30	32	31.75	2
MCYRR-45 MCYR-45	MCYRR-45-S MCYR-45-S	45	44.988	85	30	32	31.75	2
MCYRR-50 MCYR-50	MCYRR-50-S MCYR-50-S	50	49.988	90	30	32	31.75	2

(1) Standard bearing has a crowned roller outside diameter. For straight cylindrical outside diameter, add suffix "X". (Example - MCYRR-15-X or MCYR-15-SX)
 (2) Tolerance limits for Roller Diameter are shown below.

Cylindrical Roller Dia. "RD"

RD (NOM.)		TOLERANCE	
OVER	INCL.	MAX.	MIN.
mm	mm	mm	mm
6	18	0	-0.008
18	30	0	-0.009
30	50	0	-0.011
50	80	0	-0.013
80	120	0	-0.015

Crowned Roller Dia. "RD"

RD (NOM.)		TOLERANCE	
OVER	INCL.	MAX.	MIN.
mm	mm	mm	mm
6	120	0	-0.050

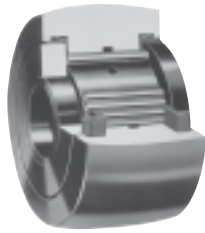

MCYRR-S

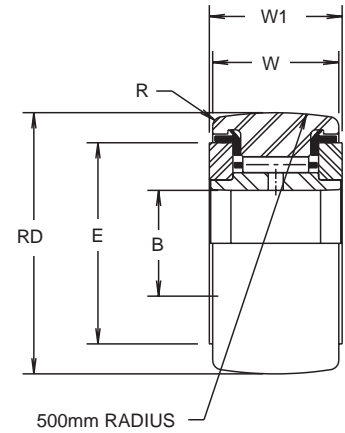

UNSEALED BEARING NUMBER (1)	SEALED BEARING NUMBER (1)	MOUNTING DIMENSIONS					LIMITING SPEED		LOAD RATINGS				MASS kg
		SHAFT DIAMETER (3)				CLAMPING DIA. E	GREASE (4)	OIL (4)	ISO/ABMA BASIC LOAD RATINGS NEWTONS		TRACK ROLLER LOAD RATINGS NEWTONS		
		LOOSE FIT FOR LIGHT LOADS g6		LIGHT TRANSITION FIT FOR MEDIUM LOADS h6					DYNAMIC	STATIC	DYNAMIC	STATIC	
		MAX.	MIN.	MAX.	MIN.	MIN.							
		mm	mm	mm	mm	mm	rpm	rpm			(5)		
MCYRR-5 MCYR-5	MCYRR-5-S MCYR-5-S	4.996	4.988	5	4.992	11	19500 13000	25000 17000	4120 6960	4120 8340	3430 5790	3380 6900	0.011 0.014
MCYRR-6 MCYR-6	MCYRR-6-S MCYR-6-S	5.996	5.988	6	5.992	13	15500 10500	20000 13500	4510 8040	5000 10490	3730 6670	4090 8760	0.018 0.021
MCYRR-8 MCYR-8	MCYRR-8-S MCYR-8-S	7.995	7.986	8	7.991	16	12500 8400	16000 11000	6860 11470	7750 15200	5690 9610	6450 12600	0.040 0.043
MCYRR-10 MCYR-10	MCYRR-10-S MCYR-10-S	9.995	9.986	10	9.991	19	9600 6400	12500 8300	8240 13340	9710 18240	6860 11080	8050 15300	0.060 0.062
MCYRR-12 MCYR-12	MCYRR-12-S MCYR-12-S	11.994	11.983	12	11.989	21	8100 5400	10500 7000	8730 14420	10890 20890	7260 12060	9120 17400	0.067 0.069
MCYRR-15 MCYR-15	MCYRR-15-S MCYR-15-S	14.994	14.983	15	14.989	24	6300 4200	8200 5400	13040 20300	19030 34130	10890 16970	15900 28500	0.102 0.105
MCYRR-17 MCYR-17	MCYRR-17-S MCYR-17-S	16.994	16.983	17	16.989	27	4900 3300	6400 4300	15990 23240	23730 38540	13340 19420	19700 32200	0.150 0.153
MCYRR-20 MCYR-20	MCYRR-20-S MCYR-20-S	19.993	19.980	20	19.987	30	3900 2600	5000 3400	21280 30790	35700 57670	17750 25690	29800 48000	0.252 0.255
MCYRR-25 MCYR-25	MCYRR-25-S MCYR-25-S	24.993	24.980	25	24.987	36	3300 2200	4300 2900	22950 34130	41780 70410	19120 28440	34900 58700	0.278 0.284
MCYRR-30 MCYR-30	MCYRR-30-S MCYR-30-S	29.993	29.980	30	29.987	44	2500 1700	3200 2200	34030 49720	65120 107290	28340 41480	54300 89000	0.465 0.476
MCYRR-35 MCYR-35	MCYRR-35-S MCYR-35-S	34.991	34.975	35	34.984	52	2200 1500	2800 1900	38930 56880	72960 120230	32460 47370	60900 100000	0.636 0.649
MCYRR-40 MCYR-40	MCYRR-40-S MCYR-40-S	39.991	39.975	40	39.984	58	1900 1300	2400 1700	49720 70020	94440 147990	41480 58350	78700 123000	0.825 0.845
MCYRR-45 MCYR-45	MCYRR-45-S MCYR-45-S	44.991	44.975	45	44.984	63	1800 1200	2300 1500	51190 73750	101010 163190	42760 61490	84100 136000	0.901 0.924
MCYRR-50 MCYR-50	MCYRR-50-S MCYR-50-S	44.991	49.975	50	49.984	68	1600 1100	2000 1400	54720 77180	113570 178390	45600 64330	94800 148000	0.960 0.984

- (3) For a tight fit and heavy loads, use ISO tolerance j6.
- (4) Since load, lubrication method, temperature and other factors affect the maximum operating speed, it is impossible to determine precise limiting speed. The listed limiting speeds are based on lightly loaded bearings having adequate lubrication and are listed only as a design guide. If grease lubricated, frequent relubrications is required. Actual bearing testing in the specific application should be conducted if the anticipated operating speed approaches the listed limiting speed.
- (5) Dynamic load should not exceed 50% of Dynamic Rating as a track roller.

CAMROL® Bearings

MCFD® SERIES

STUD TYPE

Series MCFD® — Shielded, full complement of cylindrical rollers

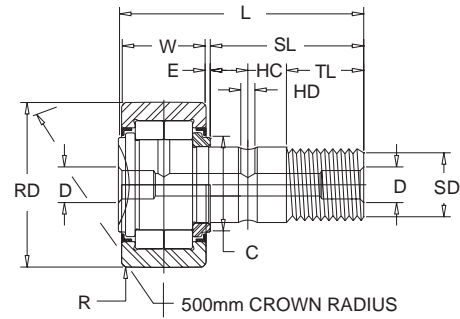

MCFD®

BEARING NO.	ROLLER DIA. RD (1)	ROLLER WIDTH W	STUD DIA. SD	STUD L'GTH. SL	OVERALL LENGTH L	ENDPLATE EXTENSION E	THREAD	THREAD LENGTH TL	OIL HOLE		REAMED HOLE D
	NOM.	+0.00 -0.12	NOM.	NOM.	NOM.	NOM.		MIN.	HC NOM.	HD NOM.	NOM.
	mm	mm	mm	mm	mm	mm		mm	mm	mm	mm
MCFD-35	35	18	16	32.5	52	0.8	M16x1.5	17	8	3	6
MCFD-40	40	20	18	36.5	58	0.8	M18x1.5	19	8	3	6
MCFD-47	47	24	20	40.5	66	0.8	M20x1.5	21	9	4	8
MCFD-52	52	24	20	40.5	66	0.8	M20x1.5	21	9	4	8
MCFD-62	62	29	24	49.5	80	0.8	M24x1.5	25	11	4	8
MCFD-72	72	29	24	49.5	80	0.8	M24x1.5	25	11	4	8
MCFD-80	80	35	30	63.0	100	1.0	M30x1.5	32	15	4	8
MCFD-90	90	35	30	63.0	100	1.0	M30x1.5	32	15	4	8

BEARING NO.	CORNER RADIUS R MIN.	ENDPLATE DIA. C	CLAMPING TORQUE (3) MAX.	LIMITING SPEED (2)		HOUSING BORE DIA.		LOAD RATING (NEWTONS)				BRG. MASS (APPROX.) Kg
				GREASE	OIL	mm		ISO LOAD RATING		LOAD RATING AS TRACK ROLLER		
						rpm	rpm	MIN.	MAX.	DYNAMIC	STATIC	
MCFD-35	0.6	21	57	6500	8500	16.000	16.018	23000	27000	16000	18000	.165
MCFD-40	1.0	23	85	5500	7200	18.000	18.018	25000	31000	18000	22000	.242
MCFD-47	1.0	27	118	4200	5500	20.000	20.021	38000	48000	27000	32000	.380
MCFD-52	1.0	21	118	3400	4400	20.000	20.021	42000	57000	30000	35000	.450
MCFD-62	1.0	38	216	2600	3400	24.000	24.021	58000	76000	41000	48000	.795
MCFD-72	1.1	44	216	2100	2700	24.000	24.021	64000	89000	46000	57000	1.010
MCFD-80	1.1	47	441	1800	2300	30.000	30.021	94000	129000	67000	91000	1.540
MCFD-90	1.1	47	441	1800	2300	30.000	30.021	94000	129000	67000	101000	1.960

- (1) Standard bearing has a crowned roller outside diameter. For straight cylindrical outside diameter, add suffix "X". (Example - MCFD-35-X)
- (2) Since load, lubrication method, temperature and other factors affect the maximum operating speed, it is impossible to determine precise limiting speed. The listed limiting speeds are based on lightly loaded bearings having adequate lubrication and are listed only as a design guide. If grease lubricated, frequent relubrication is required. Actual bearing testing in the specific application should be conducted if the anticipated operating speed approaches the listed limiting speed.
- (3) Clamping torque is based on dry threads. If threads are lubricated, use half of value shown.

Tolerance limits for Cylindrical Roller Dia. "RD"

RD (NOM.)		TOLERANCE	
OVER	INCL.	MAX.	MIN.
mm	mm	mm	mm
30	50	0	-0.011
50	80	0	-0.013
80	120	0	-0.015

Tolerance limits for Crowned Roller Dia. "RD"

RD (NOM.)		TOLERANCE	
OVER	INCL.	MAX.	MIN.
mm	mm	mm	mm
30	120	0	-0.050

Tolerance limits for Stud Dia. "SD"

SD (NOM.)		TOLERANCE	
OVER	INCL.	MAX.	MIN.
mm	mm	mm	mm
10	18	0	-0.018
18	30	0	-0.021

YOKE TYPE

Series MCYRD® — Shielded, full complement of cylindrical rollers

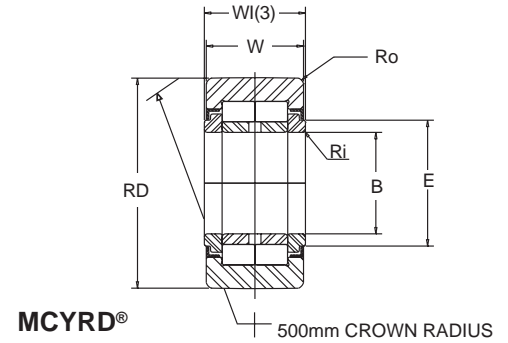

BEARING NO.	BORE DIA. B		ROLLER DIA. RD (1)	W. +0.00 -0.12	BEARING WIDTH WI		CORNER HEIGHT MIN.		WASHER DIA. E	LOAD RATING (NEWTONS)				LIMITING SPEED (2)	BRG. MASS (APPROX.)
	MAX.	MIN.			MAX.	MIN.	Ro	Ri		ISO LOAD RATING		LOAD RATING AS TRACK ROLLER			
	mm	mm			mm	mm	mm	mm		DYNAMIC	STATIC	DYNAMIC	STATIC		
MCYRD-15	15	14.992	35	18	19	18.79	0.6	0.3	20	23000	27000	16000	18000	6500	0.099
MCYRD-17	17	16.992	40	20	21	20.79	1.0	0.3	22	25000	31000	18000	22000	5500	0.147
MCYRD-20	20	19.990	47	24	25	24.79	1.0	0.3	27	38000	48000	27000	32000	4200	0.245
MCYRD-25	25	24.990	52	24	25	24.79	1.0	0.3	31	42000	57000	30000	35000	3400	0.281
MCYRD-30	30	29.990	62	28	29	28.79	1.0	0.3	38	58000	76000	41000	47000	2600	0.465
MCYRD-35	35	34.988	72	28	29	28.79	1.1	0.6	44	64000	89000	46000	57000	2100	0.630
MCYRD-40	40	39.988	80	30	32	31.75	1.1	0.6	51	89000	130000	64000	71000	1600	0.816
MCYRD-45	45	44.988	85	30	32	31.75	1.1	0.6	55	94000	143000	67000	72000	1400	0.883
MCYRD-50	50	49.988	90	30	32	31.75	1.1	0.6	60	99000	156000	71000	77000	1300	0.950

- Standard bearing has a crowned roller outside diameter. For straight cylindrical outside diameter, add suffix "X". (Example - MCYRD-15-X)
- Since load, lubrication method, temperature and other factors affect the maximum operating speed, it is impossible to determine precise limiting speed. The listed limiting speeds are based on lightly loaded bearings having adequate lubrication and are listed only as a design guide. If grease lubricated, frequent relubrication is required. Actual bearing testing in the specific application should be conducted if the anticipated operating speed approaches the listed limiting speed.
- Positive clamping across end plates required to insure proper end play after mounting.

Tolerance limits for roller diameter

Cylindrical Roller Dia. "RD"

RD (NOM.)		TOLERANCE	
OVER	INCL.	MAX.	MIN.
mm	mm	mm	mm
6	18	0	-0.008
18	30	0	-0.009
30	50	0	-0.011
50	80	0	-0.013
80	120	0	-0.015

Crowned Roller Dia. "RD"

RD (NOM.)		TOLERANCE	
OVER	INCL.	MAX.	MIN.
mm	mm	mm	mm
6	120	0	-0.050

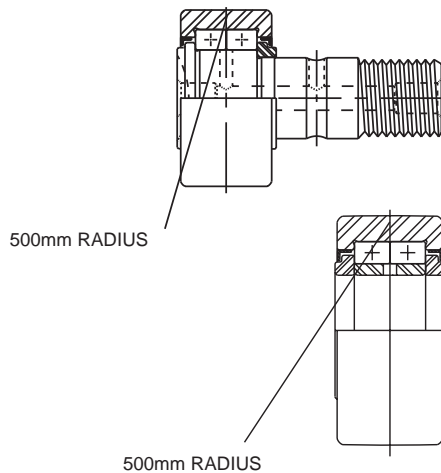

**Stud Type,
Full Complement
Cylindrical Rollers,
Metric Series.**

**Yoke Type,
Full Complement
Cylindrical Rollers,
Metric Series.**

Interchangeability Charts

* INA® FAG® NTN®	McGILL
NUKR-35	MCYRD-35
NUKR-40	MCYRD-40
NUKR-47	MCYRD-47
NUKR-52	MCYRD-52
NUKR-62	MCYRD-62
NUKR-72	MCYRD-72
NUKR-80	MCYRD-80
NUKR-90	MCYRD-90

* INA® FAG®	* NTN®	McGILL
NUTR-15	NUTR-202	MCYRD-15
NUTR-17	NUTR-203	MCYRD-17
NUTR-20	NUTR-204	MCYRD-20
NUTR-25	NUTR-205	MCYRD-25
NUTR-30	NUTR-206	MCYRD-30
NUTR-35	NUTR-207	MCYRD-35
NUTR-40	NUTR-208	MCYRD-40
NUTR-45	NUTR-209	MCYRD-45
NUTR-50	NUTR-210	MCYRD-50

* The trademark INA is a registered trademark of Industriewerk Schaeffler, O. H. G. The trademark FAG is a registered trademark of Kugelfischer Georg Schafer & Co. The trademark NTN is a registered trademark of The Toyo Bearing Manufacturing Co., Ltd.

Yoke type
Unsealed
Cage and full complement types

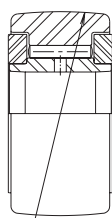

500mm RADIUS

* INA®	* SKF®	* NTN®	IKO		McGILL	
CAGE	FULL COMPLEMENT		CAGE	FULL COMPLEMENT	CAGE	FULL COMPLEMENT
NATR-5	NATV-5		NART-5R	NART-5VR	MCYRR-5	MCYR-5
NATR-6	NATV-6		NART-6R	NART-6VR	MCYRR-6	MCYR-6
NATR-8	NATV-8		NART-8R	NART-8VR	MCYRR-8	MCYR-8
NATR-10	NATV-10		NART-10R	NART-10VR	MCYRR-10	MCYR-10
NATR-12	NATV-12		NART-12R	NART-12VR	MCYRR-12	MCYR-12
NATR-15	NATV-15		NART-15R	NART-15VR	MCYRR-15	MCYR-15
NATR-17	NATV-17		NART-17R	NART-17VR	MCYRR-17	MCYR-17
NATR-20	NATV-20		NART-20R	NART-20VR	MCYRR-20	MCYR-20
NATR-25	NATV-25		NART-25R	NART-25VR	MCYRR-25	MCYR-25
NATR-30	NATV-30		NART-30R	NART-30VR	MCYRR-30	MCYR-30
NATR-35	NATV-35		NART-35R	NART-35VR	MCYRR-35	MCYR-35
NATR-40	NATV-40		NART-40R	NART-40VR	MCYRR-40	MCYR-40
NATR-45	-		NART-45R	NART-45VR	MCYRR-45	MCYR-45
NATR-50	NATV-50		NART-50R	NART-50VR	MCYRR-50	MCYR-50

Coding for Other Cam Follower and Yoke Roller Types

OPTIONAL FEATURES	* INA® * SKF®	IKO	* NTN®	* THK®	McGILL
Seals	Add Suffix "PP"	Add Suffix "UU"	Add Suffix "LL"	Add Suffix "UU"	Add Suffix "S"
Cylindrical OD	Add Suffix "X"	Remove Suffix "R"	Add Suffix "X"	Remove Suffix "R"	Add Suffix "X"
Hexagonal Hole*	Add Suffix "SK"	Add Suffix "B"	Add Suffix "H"	Add Suffix "A"	Add Suffix "B"
Eccentric Collar*	Add Prefix "E"	Add Prefix "E"	-	-	Add Prefix "E"

*Not applicable for yoke roller types

Stud type
Unsealed
Cage and full complement types

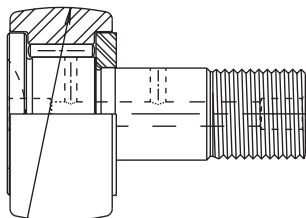

500mm RADIUS

* INA®	* SKF®	* NTN®	IKO		McGILL	
CAGE	FULL COMPLEMENT		CAGE	FULL COMPLEMENT	CAGE	FULL COMPLEMENT
-	-		CF5	-	MCFR-13	-
KR-16	KRV-16		CF6R	CF6VR	MCFR-16	MCF-16
KR-19	KRV-19		CF8R	CF8VR	MCFR-19	MCF-19
KR-22	KRV-22		-	-	MCFR-22	MCF-22
-	-		CF10R	CF10VR	MCFR-22A	MCF-22A
KR-26	KRV-26		-	-	MCFR-26	MCF-26
-	-		CF10-1R	CF10-1VR	MCFR-26A	MCF-26A
KR-30	KRV-30		CF12R	CF12VR	MCFR-30	MCF-30
KR-32	KRV-32		CF12-1R	CF12-1VR	MCFR-32	MCF-32
KR-35	KRV-35		CF16R	CF16VR	MCFR-35	MCF-35
KR-40	KRV-40		-	-	MCFR-40	MCF-40
-	-		CF18R	CF18VR	MCFR-40A	MCF-40A
KR-47	KRV-47		-	-	MCFR-47	MCF-47
-	-		CF20-1R	CF20-1VR	MCFR-47A	MCF-47A
KR-52	KRV-52		-	-	MCFR-52	MCF-52
-	-		CF20R	CF20VR	MCFR-52A	MCF-52A
KR-62	KRV-62		-	-	MCFR-62	MCF-62
-	-		CF24R	CF24VR	MCFR-62A	MCF-62A
KR-72	KRV-72		-	-	MCFR-72	MCF-72
-	-		CF24-1R	CF24-1VR	MCFR-72A	MCF-72A
KR-80	KRV-80		CF30R	CF30VR	MCFR-80	MCF-80
KR-85	-		CF30-1R	CF30-1VR	MCFR-85	MCF-85
KR-90	KRV-90		CF30-2R	CF30-2VR	MCFR-90	MCF-90

* The trademark INA is a registered trademark of Industriewerk Schaeffler, O. H. G.
 The trademark FAG is a registered trademark of Kugelfischer Georg Schafer & Co.
 The trademark NTN is a registered trademark of The Toyo Bearing Manufacturing Co., Ltd.
 The trademark SKF is a registered trademark of SKF Industries, Inc.
 The trademark THK is a registered trademark of THK Co., Ltd.

Certain applications have adverse operating conditions requiring features not available in needle roller type CAMROL® bearings. McGill offers Special Duty TRAKROL® bearings designed with ball bearing or tapered roller bearing inserts to meet these demands. Ball bearings are used for roller diameters or point diameters (VCF series) less than 3" and tapered roller bearings for roller diameters and point diameters 3" and larger. These constructions make possible successful bearing operation with various combinations of radial and thrust loads

Special sealing provisions allow operation in dirty environments. A fitted metal expansion plug closes off the head end of the Special Duty TRAKROL® Bearing. The smaller sizes contain ball bearings with rubber lip seals and have an additional NYLAPLATE® seal on the stem side for further protection. The larger sizes contain tapered roller bearings with rubber seals having a double lip. All sizes have large lubricant reservoirs and are lubricated with proper grade, type and amount of grease for extended reduced maintenance operation. These bearings have a standard operating temperature range of -30°F. to +225°F. McGill offers three different O.D. configurations to cover a variety of different applications whose operating conditions require these Special Duty TRAKROL® Bearings.

The standard configurations are Plain O.D., Flanged O.D., and "V"-grooved.

Flanged O.D. bearings are used for side guiding purposes where light side thrust loading might be present and the thrust load can be accommodated by the flange. For heavier side thrust, Plain O.D. bearings can be positioned both as side guide and main support rollers.

"V"-grooved bearings are designed to operate on "V"-bar tracks. This bearing and track arrangement is used to reduce buildup of contamination, such as sand, powder, chips, etc., which would be likely to occur if flat tracks were employed.

Plain, flanged and "V"-grooved O.D. configurations are normally available from stock.

Maximum applied static load should not exceed the rating given in charts, or excessive permanent stud deflection will occur. Maximum applied radial dynamic load should not exceed 50% of the Radial Basic Dynamic Rating listed.



FCF SERIES



PCF SERIES



VCF SERIES

PCF, VCF & FCF SERIES

PCF series

Special duty cam followers with plain O.D.'s and integral seals

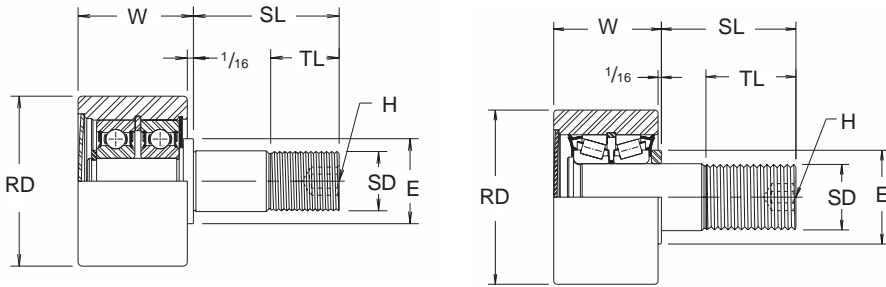

VCF series

Special duty cam followers with V-groove O.D.'s and integral seals

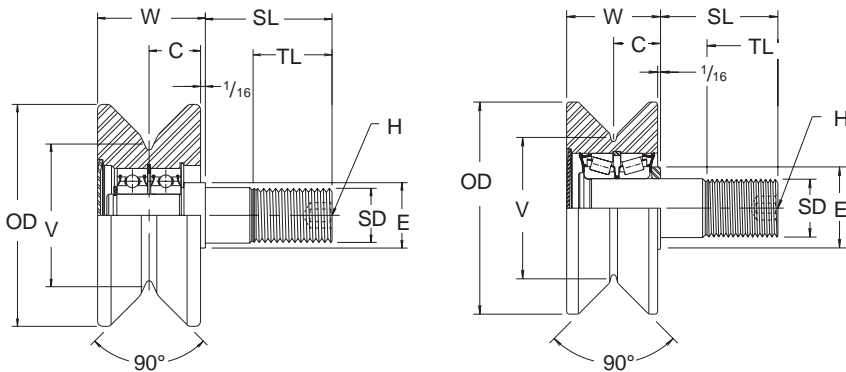

FCF series

Special duty cam followers with flanged O.D.'s and integral seals

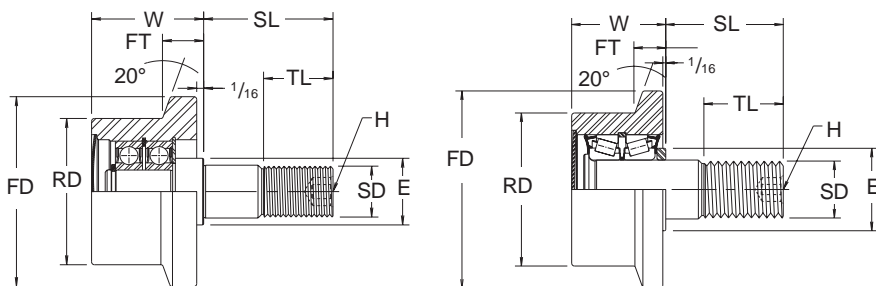

BRG. NO.	ROLLER DIA. (RD)	WIDTH (W)	STUD DIA. (SD) +.000 -.001	MIN. THREAD LENGTH (TL)	FINE THREADS	STUD LENGTH (SL)	HEX SOCKET (H)	SHOULDER OR ENDPLATE DIA. (E)	RADIAL BASIC DYNAMIC RATING (LBS.)	DYNAMIC THRUST LOAD* RATING (LBS.)	MAX. STATIC CAPACITY (LBS.)
PCF-1 1/2	1.500	1 3/16	.625	3/4	5/8-18	1 1/2	1/4	3/4	2520	1320	1370
PCF-1 3/4	1.750	1 3/16	.750	7/8	3/4-16	1 3/4	1/4	1	2520	1320	1370
PCF-2	2.000	1 11/16	.875	1 1/8	7/8-14	2	3/8	1	3490	1830	2000
PCF-2 1/4	2.250	1 11/16	.875	1 1/8	7/8-14	2	3/8	1	3490	1830	2000
PCF-2 1/2	2.500	1 11/16	1.000	1 1/2	1-14	2 1/4	7/16	1 1/4	5120	2680	3120
PCF-2 3/4	2.750	1 11/16	1.000	1 1/2	1-14	2 1/4	7/16	1 1/4	5120	2680	3120
PCF-3	3.000	2	1.250	1 3/4	1 1/4-12	2 1/2	7/16	1 3/4	14300	5790	16000
PCF-3 1/4	3.250	2	1.250	1 3/4	1 1/4-12	2 1/2	7/16	1 3/4	14300	5790	16000
PCF-3 1/2	3.500	2	1.250	1 3/4	1 1/4-12	2 3/4	7/16	1 3/4	14300	5790	16000
PCF-4	4.000	2	1.250	1 3/4	1 1/4-12	2 3/4	7/16	1 3/4	14300	5790	16000
PCF-4 1/2	4.500	2	1.250	1 3/4	1 1/4-12	2 3/4	7/16	1 3/4	14300	5790	16000
PCF-5	5.000	3	2.000	2 1/2	2-12	4 1/2	7/8	3 1/4	35800	13300	40000
PCF-6	6.000	3	2.500	3 1/4	2 1/2-12	5 1/2	7/8	3 1/4	35800	14200	62000
PCF-7	7.000	3	2.500	3 1/4	2 1/2-12	5 1/2	7/8	3 1/4	35800	14200	62000
PCF-8	8.000	3	2.500	3 1/4	2 1/2-12	5 1/2	7/8	3 1/4	35800	14200	62000

BRG. NO.	OUTSIDE ROLLER DIA. (OD)	POINT DIA. (V)	WIDTH (W)	GROOVE CENTER (C)	STUD DIA. (SD) +.000 -.001	MIN. THREAD LENGTH (TL)	FINE THREADS	STUD LENGTH (SL)	HEX SOCKET	SHOULDER OR ENDPLATE DIA. (E)	RADIAL BASIC DYNAMIC RATING (LBS.)	DYNAMIC THRUST LOAD* RATING (LBS.)	MAX. STATIC CAPACITY (LBS.)
VCF-2 1/2	2 1/2	1 1/2	1 5/16	11/16	.750	.895	3/4-16	1 3/4	1/4	1 1/4	2520	1320	1370
VCF-3 1/2	3 1/2	2 1/4	1 11/16	7/8	.875	1 1/8	7/8-14	2	3/8	1	3490	1830	2000
VCF-4 1/2	4 1/2	3	2	1	1.250	1 3/4	1 1/4-12	2 1/2	7/16	1 3/4	14300	5790	16000
VCF-5 1/2	5 1/2	4	2	1	1.250	1 3/4	1 1/4-12	2 3/4	7/16	1 3/4	14300	5790	16000
VCF-6 1/2	6 1/2	5	3	1 1/2	2.000	2 1/2	2-12	4 1/2	7/8	3 1/4	35800	13300	40000
VCF-7 1/2	7 1/2	6	3	1 1/2	2.500	3 1/4	2 1/2-12	5 1/2	7/8	3 1/4	35800	14200	62000
VCF-8 1/2	8 1/2	7	3	1 1/2	2.500	3 1/4	2 1/2-12	5 1/2	7/8	3 1/4	35800	14200	62000

BRG. NO.	ROLLER DIA. (RD)	FLANGE DIA. (FD)	WIDTH (W)	FLANGE THICKNESS (FT)	STUD DIA. (SD) +.000 -.001	MIN. THREAD LENGTH (TL)	FINE THREADS	STUD LENGTH (SL)	HEX SOCKET (H)	SHOULDER OR ENDPLATE DIA. (E)	RADIAL BASIC DYNAMIC RATING (LBS.)	DYNAMIC THRUST LOAD* RATING (LBS.)	MAX. STATIC CAPACITY (LBS.)
FCF-1 1/2	1.500	2 3/16	1 3/16	11/32	.625	3/4	5/8-18	1 1/2	1/4	3/4	2520	1320	1370
FCF-1 3/4	1.750	2 7/16	1 3/16	11/32	.750	7/8	3/4-16	1 3/4	1/4	1	2520	1320	1370
FCF-2	2.000	2 11/16	1 11/16	19/32	.875	1 1/8	7/8-14	2	3/8	1	3490	1830	2000
FCF-2 1/4	2.250	2 15/16	1 11/16	19/32	.875	1 1/8	7/8-14	2	3/8	1	3490	1830	2000
FCF-2 1/2	2.500	3 3/16	1 11/16	19/32	1.000	1 1/2	1-14	2 1/4	7/16	1 1/4	5120	2680	3120
FCF-2 3/4	2.750	3 7/16	1 11/16	19/32	1.000	1 1/2	1-14	2 1/4	7/16	1 1/4	5120	2680	3120
FCF-3	3.000	3 15/16	2	19/32	1.250	1 3/4	1 1/4-12	2 1/2	7/16	1 3/4	14300	5790	16000
FCF-3 1/4	3.250	4 3/16	2	19/32	1.250	1 3/4	1 1/4-12	2 1/2	7/16	1 3/4	14300	5790	16000
FCF-3 1/2	3.500	4 7/16	2	19/32	1.250	1 3/4	1 1/4-12	2 3/4	7/16	1 3/4	14300	5790	16000
FCF-4	4.000	4 15/16	2	19/32	1.250	1 3/4	1 1/4-12	2 3/4	7/16	1 3/4	14300	5790	16000
FCF-4 1/2	4.500	5 7/16	2	19/32	1.250	1 3/4	1 1/4-12	2 3/4	7/16	1 3/4	14300	5790	16000
FCF-5	5.000	5 15/16	3	23/32	2.000	2 1/2	2-12	4 1/2	7/8	3 1/4	35800	13300	40000
FCF-6	6.000	6 15/16	3	23/32	2.500	3 1/4	2 1/2-12	5 1/2	7/8	3 1/4	35800	14200	62000
FCF-7	7.000	7 15/16	3	23/32	2.500	3 1/4	2 1/2-12	5 1/2	7/8	3 1/4	35800	14200	62000
FCF-8	8.000	8 15/16	3	23/32	2.500	3 1/4	2 1/2-12	5 1/2	7/8	3 1/4	35800	14200	62000

* Dynamic thrust load rating based on application of a centric, axial load. Fatigue life calculations for combined radial and thrust loading require special considerations and the McGill Engineering Department should be contacted.

Interchange Chart

McGill	**** OSBORN
PCF—**	PLR
VCF —	VLR
FCF —	FLR

** Both manufacturers use the same numbering convention, i.e. a PCF-1 1/2 interchanges a PLR-1 1/2

**** The trademark OSBORN is a registered trademark of The Osborn Manufacturing Company

Recommended Installation Torque

<u>Stud Dia.</u>	<u>Installation torque*** (in.-lbs.)</u>
.625	325
.750	625
.875	750
1.000	1120
1.250	1720
2.000	2500
2.500	2500

*** Values shown are for dry threads. If threads are lubricated, use 1/2 of values shown.

ECCENTRIC SERIES

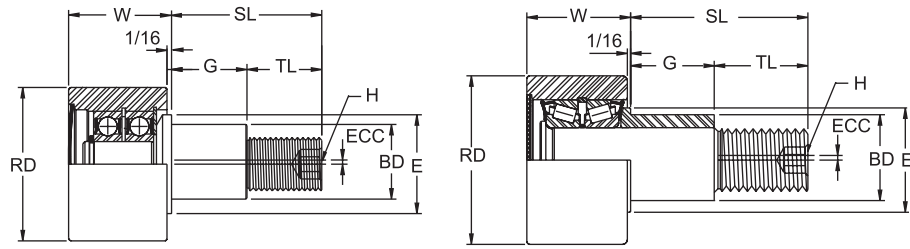

PCFE

BRG. NO.	ROLLER DIA. (RD)	WIDTH (W)	MIN. THREAD LENGTH (TL)	FINE THREADS	STUD LENGTH (SL)	ECCENTRIC DIA. (BD) +.001 -0.001	ECCENTRIC LENGTH (G) +.000 -0.010	ECCENTRIC (ECC)	HEX SOCKET (H)	SHOULDER DIAMETER (E)	RADIAL BASIC DYNAMIC RATING (LBS)	DYNAMIC THRUST LOAD RATING (LBS)	MAX. STATIC CAPACITY (LBS)
PCFE-1 1/2	1.500	1 3/16	.770	5/8-18	1 1/2	0.875	.730	.030	1/4	1 1/8	2520	1320	1370
PCFE-1 3/4	1.750	1 3/16	.895	3/4-16	1 3/4	1.000	.855	.030	1/4	1 1/4	2520	1320	1370
PCFE-2	2.000	1 11/16	1.020	7/8-14	2	1.187	.980	.030	3/8	1 1/2	3490	1830	2000
PCFE-2 1/4	2.250	1 11/16	1.020	7/8-14	2	1.187	.980	.030	3/8	1 1/2	3490	1830	2000
PCFE-2 1/2	2.500	1 11/16	1.145	1-14	2 1/4	1.375	1.105	.030	7/16	1 11/16	5120	2680	3120
PCFE-2 3/4	2.750	1 11/16	1.145	1-14	2 1/4	1.375	1.105	.030	7/16	1 11/16	5120	2680	3120
PCFE-3	3.000	2	1.270	1 1/4-12	2 1/2	1.750	1.230	.060	7/16	2 5/16	14300	5790	16000
PCFE-3 1/4	3.250	2	1.270	1 1/4-12	2 1/2	1.750	1.230	.060	7/16	2 5/16	14300	5790	16000
PCFE-3 1/2	3.500	2	1.395	1 1/4-12	2 3/4	1.812	1.355	.060	7/16	2 5/16	14300	5790	16000
PCFE-4	4.000	2	1.395	1 1/4-12	2 3/4	1.812	1.355	.060	7/16	2 5/16	14300	5790	16000

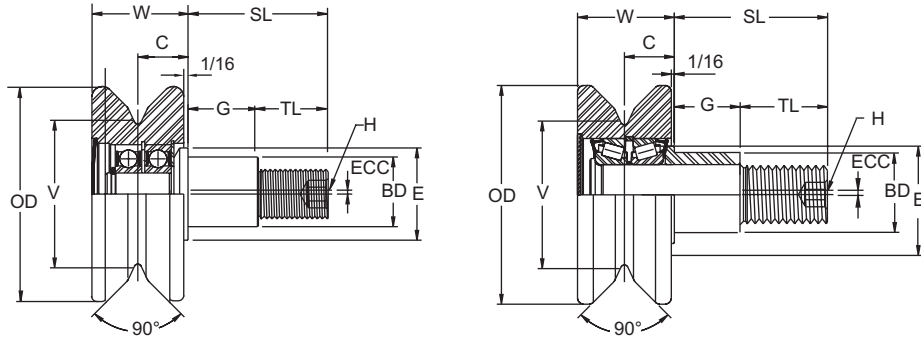

VCFE

BRG. NO.	OUTSIDE ROLLER DIA. (OD)	POINT DIA. (V)	WIDTH (W)	GROOVE CENTER (C)	MIN. THREAD LENGTH (TL)	FINE THREADS	STUD LENGTH (SL)	ECCENTRIC DIA. (BD) ±.001	ECCENTRIC LENGTH (G) +.000 -0.010	ECCENTRIC (ECC)	HEX SOCKET (H)	SHOULDER DIAMETER (E)	RADIAL BASIC DYNAMIC RATING (LBS)	DYNAMIC THRUST LOAD RATING (LBS)	MAX. STATIC CAPACITY (LBS)
VCFE-2 1/2	2 1/2	1 1/2	1 5/16	11/16	.895	3/4-16	1 3/4	1.000	.855	.030	1/4	1 1/4	2520	1320	1370
VCFE-3 1/2	3 1/2	2 1/4	1 11/16	7/8	1.020	7/8-14	2	1.187	.980	.030	3/8	1 1/2	3490	1830	2000
VCFE-4 1/2	4 1/2	3	2	1	1.270	1 1/4-12	2 1/2	1.750	1.230	.060	7/16	1 3/4	14300	5790	16000

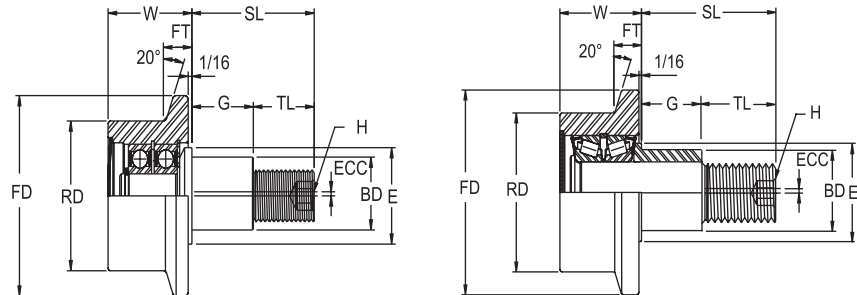

FCFE

BRG. NO.	ROLLER DIA. (RD)	FLANGE DIA. (FD)	WIDTH (W)	FLANGE THICKNESS (FT)	MIN. THREAD LENGTH (TL)	FINE THREADS	STUD LENGTH (SL)	ECCENTRIC DIA. (BD) +.001 -0.001	ECCENTRIC LENGTH (G) +.000 -0.010	ECCENTRIC (ECC)	HEX SOCKET (H)	SHOULDER DIAMETER (E)	RADIAL BASIC DYNAMIC RATING (LBS)	DYNAMIC THRUST LOAD RATING (LBS)	MAX. STATIC CAPACITY (LBS)
FCFE-1 1/2	1.500	2 3/16	1 3/16	11/32	.770	5/8-18	1 1/2	0.875	.730	.030	1/4	1 1/8	2520	1320	1370
FCFE-1 3/4	1.750	2 7/16	1 3/16	11/32	.895	3/4-16	1 3/4	1.000	.855	.030	1/4	1 1/4	2520	1320	1370
FCFE-2	2.000	2 11/16	1 11/16	19/32	1.020	7/8-14	2	1.187	.980	.030	3/8	1 1/2	3490	1830	2000
FCFE-2 1/4	2.250	2 15/16	1 11/16	19/32	1.020	7/8-14	2	1.187	.980	.030	3/8	1 1/2	3490	1830	2000
FCFE-2 1/2	2.500	3 3/16	1 11/16	19/32	1.145	1-14	2 1/4	1.375	1.105	.030	7/16	1 11/16	5120	2680	3120
FCFE-2 3/4	2.750	3 7/16	1 11/16	19/32	1.145	1-14	2 1/4	1.375	1.105	.030	7/16	1 11/16	5120	2680	3120
FCFE-3	3.000	3 15/16	2	19/32	1.270	1 1/4-12	2 1/2	1.750	1.230	.060	7/16	2 5/16	14300	5790	16000
FCFE-3 1/4	3.250	4 3/16	2	19/32	1.270	1 1/4-12	2 1/2	1.750	1.230	.060	7/16	2 5/16	14300	5790	16000
FCFE-3 1/2	3.500	4 7/16	2	19/32	1.395	1 1/4-12	2 3/4	1.812	1.355	.060	7/16	2 5/16	14300	5790	16000
FCFE-4	4.000	4 15/16	2	19/32	1.395	1 1/4-12	2 3/4	1.812	1.355	.060	7/16	2 5/16	14300	5790	16000

CAGEROL® cage type heavy-duty roller bearings

Cage type CAGEROL® bearings from McGill are designed especially to meet the performance requirements of applications where greater shaft misalignment and higher speeds exceed the capabilities of ordinary full complement needle roller bearings. Bearing life can often be extended up to ten times that of ordinary end guided needle bearings.

In this McGill design, a precision tubular cage spaces and locates specially heat treated crowned rollers. They are positively controlled to insure concentricity and prevent temperature increases at higher speeds.

MR series CAGEROL® bearings are interchangeable dimensionally with all heavy-duty needle bearings. They are available with or without separable inner races.

Built for the tougher applications, CAGEROL® bearings feature many design and construction advantages. The McGill engineering department can make helpful recommendations.

The application of CAGEROL® bearings from McGill involves many factors other than those listed in the dimensional tables. Typical of these factors would be: metallurgy, types of fit requirements, lubrication, types of load, etc. This information is also covered in detail in the general Engineering Section beginning on page 2.

GUIDEROL® heavy-duty needle bearings with center-guided rollers

Incorporating the first practical application of roller guiding - in full complement needle-type roller bearings

GUIDEROL® bearings is the trademarked designation for McGill® bearings having a full complement of rollers extending the complete width of the races for maximum support. These rollers are undercut on the O.D. to a determined dimension each side of center to form a circumferential groove. This groove is designed to fit a rectangular matching guide rail extending below the bore of the outer race. Action of the rollers against the rail limits skewing and eliminates any tendency for the bearing to bind under limited misalignment.

Greater static capacity and angular rigidity

The extra long rollers give support to the full width of the races. This, in addition to the full complement of rollers, assures maximum static capacity in a given size. Such wide support is particularly valuable in such single unit applications as gears, rollers, sheaves, levers, etc.

CAGEROL® - GUIDEROL® bearing engineering section

Type selection

Ordinarily, the equipment and operating conditions definitely limit the type of bearing which should be incorporated in an application. Likewise, the designer often has a preference due to previous experience. However, to further assist in making selection, the following points will serve as a general guide should there be any question as to whether a CAGEROL® or GUIDEROL® bearing would be the proper type bearing for the application.

CAGEROL® roller bearing should be used when:

- (1) Radial space is limited.
- (2) Maximum radial load rating within space limitation is required.
- (3) Higher speeds are present.
- (4) Thrust load is non-existent, or if existent, supported by means other than the CAGEROL® bearing.

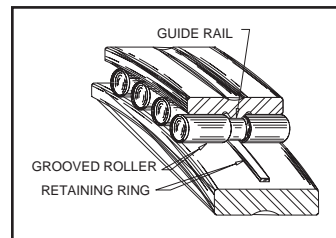

CAGEROL®/GUIDEROL® Bearings

ENGINEERING SECTION

- (5) Greater misalignment is present.
- (6) Lower internal friction is required.
- (7) Greater lubrication reservoir is required.

GUIDEROL roller bearing should be used when:

- (1) Radial rigidity is required. GUIDEROL® bearings may be applied with little or no internal looseness as well as for applications requiring normal looseness.
- (2) Maximum radial load rating within space limitation is required.
- (3) Thrust load is non-existent, or if existent, is supported by means other than the GUIDEROL® bearing.
- (4) Speed is in the lower range, i.e., lower than ordinarily associated with ball bearing speeds. GUIDEROL® bearings are ideally suited for oscillating motion.
- (5) Slightly greater internal friction as compared with ball bearings is not detrimental.

Shaft materials and their treatment

In order to obtain the performance built into needle and radial roller bearings when applied without inner races, it is important that the bearing user employ the best possible shaft material and heat treatment.

This is especially critical in cases of outer race rotation where the shaft becomes the weakest member of the bearing assembly. Sheave applications would be typical and are shown in Fig. 1, and additional applications are shown on Figs. 2 and 3 (next page). Manufacturing simplicity as well as reduced operating clearances can be obtained by omission of inner races with their extra expense, as well as build-up of tolerances. This construction is employed frequently in the application of needle bearings and to a somewhat lesser degree in radial roller bearings.

With the conventional application using inner races, the selection of shaft material is principally a matter of manufacturing economy coupled with proper bending and tensile strength, and in most cases surface heat treatments of shafts are dispensed with. However, when the inner race is eliminated, the shaft then becomes an integral member of the bearing and the three following areas must be accurately and correctly covered for best bearing performance:

- 1) Shaft material selection.
- 2) Shaft heat treatment.
- 3) Shaft surface finish.

Under item 1, there are a number of satisfactory shaft materials which can be employed and they can be broken down into two groups as follows:

- 1) Thru-hardening or induction hardening material.
- 2) Case hardening material.

Where thru-hardening or induction hardening materials are employed, a sound material would be SAE 52100 steel, such as employed by the bearing manufacturers. This material may be induction zone hardened, or thru-hardened in accordance with the dictates of the application. However, as shaft material in the thru-hardened state, the high core hardness of the 52100 steel causes brittleness that may be objectionable.

Zone hardening or induction hardening that provides a tougher core is usually more satisfactory for shaft applications. Alternate materials, such as SAE 1050, SAE 1150 may be used, employing the induction or flame hardening process. While these steels will induction harden satisfactorily to give the proper hardness ranges, they will not offer the fatigue resistance of the higher alloy content steels.

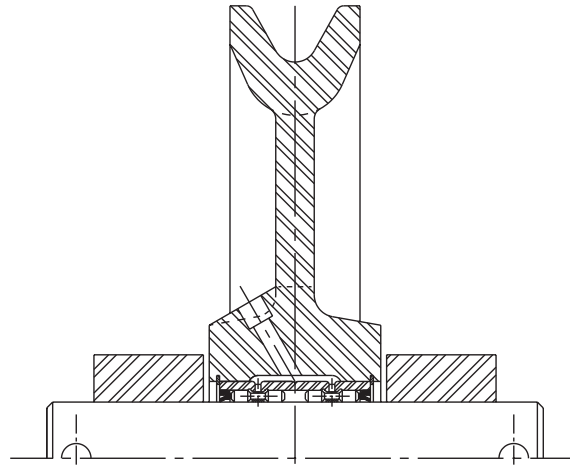

**SHEAVE APPLICATION
RS Duplex Mounting**

Fig. 1

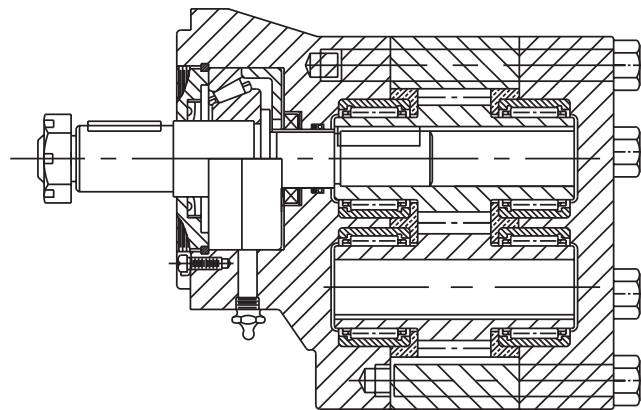

GEAR PUMP APPLICATION

Fig. 2

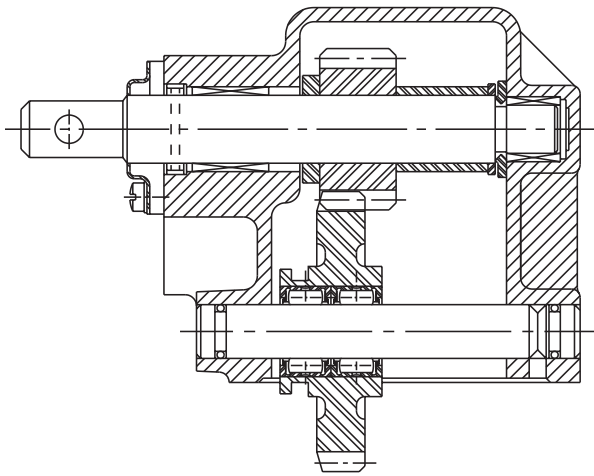

POWER TAKE-OFF APPLICATION

Fig. 3

Examples of higher alloy steels are SAE 4650, SAE 8650, etc. These materials do not require carburization for induction hardening. However, as mentioned above, the absence of excess carbides in the surface structure of the material after heat treatment reduces the fatigue life of the material correspondingly. Hardnesses in the range of R_c 60 should be maintained under all circumstances.

For case hardening, any number of materials can be employed, ranging from the plain carbon SAE 1010 to 1020 up through SAE 4615, 4620, 8615 and 8620. Shafts can be completely carburized and case hardened or zone hardened by masking or copper plating areas desired left in soft state. A minimum hardness of R_c 58 should be employed. For the best quality of heat treatment, it is imperative that the hardening temperature in both the induction and thru-hardening process be held to rather close limits, in order to avoid the formation of retained austenite. In water quenching of induction hardened steels, the cracking of shafts after treatment should be avoided by immediate tempering.

A practical maximum surface finish for shafts being used as inner races would be 12 AA. Rougher surface finishes can be employed; however, the user will run the risk of more erratic performance due to the wearing in of the shaft as well as a lesser control of dimensional accuracy of the mounted bearing. All bearings wear in to a certain extent and the amount of "wear-in" depends directly upon the surface finish of the mating parts. The rougher the surface the greater the "wear-in" and the greater range of resultant clearance which would ensue.

Another major factor which is sometimes incorrectly specified or ignored by the bearing user is the establishment of proper carburizing case depths. Since the determination of the case depth of carburized parts can have an effect both on the unit cost of such parts as well as the fatigue performance of bearing components, it is advantageous to have some method of calculation for case depths.

Since the depth of case on shaft surfaces which are used in conjunction with anti-friction bearings is a function of the sub-surface shear stress set up by the roller in contact with the shaft, this is the first consideration for case depth calculation. It has been determined empirically that the case depth should be a minimum of four times the depth to the point of maximum sub-surface shear stress.

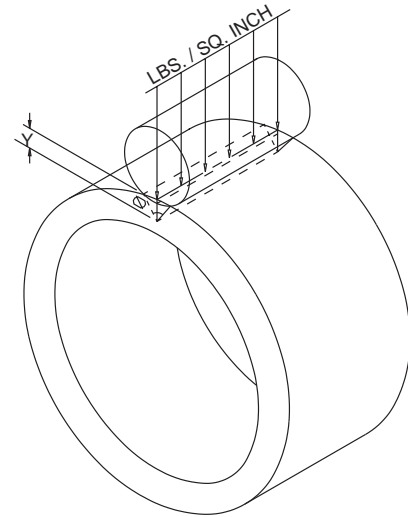

INNER RACE or SHAFT

$$Y_i = .000427 \sqrt{\frac{F_R}{ZL \left(\frac{1}{D_R} + \frac{1}{D_i} \right)}}$$

$$Y_o = .000427 \sqrt{\frac{F_R}{ZL \left(\frac{1}{D_R} - \frac{1}{D_o} \right)}}$$

It is often advantageous to know whether or not the maximum loading to which bearing component is subjected will not exceed the allowable values set for sub-surface shear, and in order to evaluate these loads, the following formulae will apply:

$$(S_s \text{ Maximum})_o = 2645 \sqrt{\frac{F_R}{ZL \left[\frac{1}{D_R} - \frac{1}{D_o} \right]}}$$

Where:

$(S_s \text{ Maximum})_o$ = Maximum sub-surface shear stress outer race (Pounds per square inch).

$$(S_s \text{ Maximum})_i = 2645 \sqrt{\frac{F_R}{ZL \left[\frac{1}{D_R} + \frac{1}{D_i} \right]}}$$

Where:

$(S_s \text{ Maximum})_i$ = Maximum sub-surface shear stress inner race (Pounds per square inch).

Where:

Y_i = Depth to point of maximum sub-surface shear stress inner race (inches).

Y_o = Depth to point of maximum sub-surface shear stress outer race (inches).

F_R = Estimated radial load on bearing (pounds).

Z = Number of rollers.

L = Effective roller length (inches).

D_R = Roller diameter (inches).

D_i = Inner race diameter (inches).

D_o = Outer race diameter (inches).

MR SERIES

Outer ring and roller assembly with separable inner ring

Outer ring and roller assemblies and associated inner rings are packed and shipped separately. For a complete bearing, specify both outer and inner numbers desired.

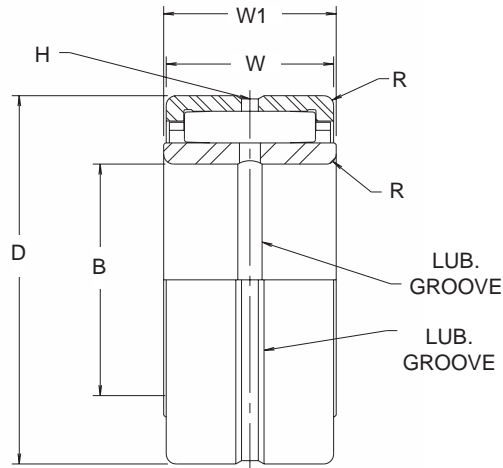

McGILL NUMBER outer ring & roller assy.	McGILL NUMBER inner ring only	MILITARY STANDARD NUMBER	B		D		W	W1	H	R	SHAFT DIA.				HSG. BORE DIA.				STATIC LOAD RATING (LBS.)	BASIC DYNAMIC RATING (LBS.)	
			+0.0000	TOL.	+0.0000	TOL.	+0.000	-0.005	HOLE DIA.		MAX. FILLET for shaft & hsg.	ROTAT. SHAFT	TOL. SHAFT	STAT. SHAFT	TOL. SHAFT	ROTAT. HSG.	TOL. HSG.	STAT. HSG.			TOL. HSG.
MR-10-N	MI-6-N	MS 500072-1	.3750	-.0004	1.1250	-.0005	.750	.760	5/64	.025	.025	.3755	-.0005	.3747	-.0005	1.1247	-.0007	1.1257	-.0007	4300	4320
MR-10-N	MI-7-N		.4375		1.1250		.750	.760	5/64	.025		.4380		.4372		1.1247		1.1257		4300	4320
MR-10	MI-6		.3750		1.1250		1.000	1.010	5/64	.025		.3755		.3747		1.1247		1.1257		6500	5930
MR-12-N	MI-8-N	MS 500072-2	.5000	-.0004	1.2500	-.0005	.750	.760	5/64	.040	.040	.5005	-.0005	.4997	-.0005	1.2497	-.0007	1.2507	-.0007	5400	4990
MR-12-N	MI-9-N		.5625		1.2500		.750	.760	5/64	.040		.5630		.5623		1.2497		1.2507		5400	4990
MR-12	MI-8	MS 500072-3	.5000		1.2500		1.000	1.010	5/64	.040		.5005		.4997		1.2497		1.2507		8100	6830
MR-14-N	MI-10-N	MS 500072-4	.6250	-.0004	1.3750	-.0005	.750	.760	5/64	.040	.040	.6255	-.0005	.6247	-.0005	1.3747	-.0007	1.3757	-.0007	6000	5280
MR-14-N	MI-11-N		.6875		1.3750		.750	.760	5/64	.040		.6880		.6872		1.3747		1.3757		6000	5280
MR-14	MI-10		.6250		1.3750		1.000	1.010	5/64	.040		.6255		.6247		1.3747		1.3757		9000	7240
MR-16-N	MI-12-N	MS 500072-5	.7500	-.0004	1.5000	-.0005	.750	.760	5/64	.040	.040	.7505	-.0005	.7497	-.0005	1.4997	-.0007	1.5007	-.0007	7100	5840
MR-16-N	MI-13-N	MS 500072-6	.8125		1.5000		.750	.760	5/64	.040		.8129		.8121		1.4997		1.5007		7100	5840
MR-16	MI-12		.7500		1.5000		1.000	1.010	5/64	.040		.7505		.7497		1.4997		1.5007		10600	8000
MR-16	MI-13	MS 500072-7	.8125	-.0004	1.5000	-.0005	1.000	1.010	5/64	.040	.040	.8129	-.0005	.8121	-.0005	1.4997	-.0007	1.5007	-.0007	10600	8000
MR-18-N	MI-14-N	MS 500072-8	.8750		1.6250		1.000	1.010	3/32	.040		.8754		.8746		1.6247		1.6257		12200	8720
MR-18-N	MI-15-N	MR 500072-9	.9375		1.6250		1.000	1.010	3/32	.040		.9379		.9371		1.6247		1.6257		12200	8720
MR-18	MI-14		.8750	-.0005	1.6250	-.0005	1.250	1.260	3/32	.040	.040	.8754	-.0005	.8746	-.0005	1.6247	-.0007	1.6257	-.0007	16300	10900
MR-18	MI-15		.9375		1.6250		1.250	1.260	3/32	.040		.9379		.9371		1.6247		1.6257		16300	10900
MR-20-N	MI-16-N	MS 500072-10	1.0000		1.7500		1.000	1.010	3/32	.040		1.0004		.9996		1.7497		1.7507		13100	9020
MR-20	MI-16	MS 500072-11	1.0000	-.0005	1.7500	-.0005	1.250	1.260	3/32	.040	.040	1.0004	-.0005	.9996	-.0005	1.7497	-.0007	1.7507	-.0007	17500	11300
MR-22-N	MI-17-N	MS 500072-12	1.1250		1.8750		1.000	1.010	3/32	.040		1.1255		1.1246		1.8747		1.8757		14700	9640
MR-22	MI-17		1.0625		1.8750		1.250	1.260	3/32	.040		1.0630		1.0621		1.8747		1.8757		19700	12100
MR-22	MI-18	MS 500072-13	1.1250	-.0005	1.8750	-.0005	1.250	1.260	3/32	.040	.040	1.1255	-.0005	1.1246	-.0005	1.8747	-.0007	1.8757	-.0007	19700	12100
MR-24-N	MI-20-N	MS 500072-15	1.2500		2.0625		1.000	1.010	3/32	.060		1.2505		1.2496		2.0621		2.0632		15500	10300
MR-24	MI-19	MS 500072-14	1.1875		2.0625		1.250	1.260	3/32	.060		1.1880		1.1871		2.0621		2.0632		20800	13000
MR-24	MI-20	MS 500072-16	1.2500	-.0006	2.0625	-.0006	1.250	1.260	3/32	.060	.060	1.2505	-.0006	1.2496	-.0006	2.0621	-.0007	2.0632	-.0007	20800	13000
MR-26-N	MI-21-N	MS 500072-17	1.3125		2.1875		1.000	1.010	3/32	.060		1.3130		1.3121		2.1871		2.1882		16400	10600
MR-26	MI-21		1.3125		2.1875		1.250	1.260	3/32	.060		1.3130		1.3121		2.1871		2.1882		22100	13300
MR-26	MI-22-4S	MS 500072-18	1.3750	-.0006	2.1875	-.0006	1.250	1.260	3/32	.060	.060	1.3755	-.0006	1.3746	-.0006	2.1871	-.0007	2.1882	-.0007	22100	13300
MR-28-N	MI-24-N	MS 500072-21	1.5000		2.3125		1.000	1.010	3/32	.060		1.5005		1.4996		2.3121		2.3132		18100	11200
MR-28	MI-22	MS 500072-19	1.3750		2.3125		1.250	1.260	3/32	.060		1.3755		1.3746		2.3121		2.3132		24400	14100
MR-28	MI-23	MS 500072-20	1.4375	-.0006	2.3125	-.0006	1.250	1.260	3/32	.060	.060	1.4380	-.0006	1.4371	-.0006	2.3121	-.0007	2.3132	-.0007	24400	14100
MR-28	MI-24	MS 500072-22	1.5000		2.3125		1.250	1.260	3/32	.060		1.5005		1.4996		2.3121		2.3132		24400	14400

McGILL NUMBER outer ring & roller assy.	McGILL NUMBER inner ring only	MILITARY STANDARD NUMBER	B		D		W	W1	H	R	SHAFT DIA.				HSG. BORE DIA.				STATIC LOAD RATING (LBS.)	BASIC DYNAMIC RATING (LBS.)
			+ .0000	TOL.	+ .0000	TOL.	+ .0000 -.0005	+ .0000 -.0005	HOLE DIA.	MAX. FILLET for shaft & hsg.	ROTAT. SHAFT	TOL. + .0000	STAT. SHAFT	TOL. + .0000	ROTAT. HSG.	TOL. + .0000	STAT. HSG.	TOL. + .0000		
MR-30	MI-25-4S		1.5625		2.4375		1.250	1.260	3/32	.060	1.5630		1.5621		2.4371		2.4382		25600	14400
MR-31	MI-26-2S		1.6250		2.5000		1.250	1.260	3/32	.060	1.6255		1.6246		2.4996		2.5007		22400	12400
MR-32-N	MI-26-N		1.6250		2.5625		1.000	1.010	3/32	.060	1.6255		1.6246		2.5621		2.5632		20700	12000
MR-32	MI-25		1.5625		2.5625		1.250	1.260	3/32	.060	1.5630		1.5621		2.5621		2.5632		27900	15200
MR-32	MI-26	MS 500072-23	1.6250		2.5625		1.250	1.260	3/32	.060	1.6255		1.6246		2.5621		2.5632		27900	15200
MR-32	MI-27		1.6875		2.5625		1.250	1.260	3/32	.060	1.6880		1.6871		2.5621		2.5632		27900	15200
MR-36-N	MI-28-N	MS 500072-24	1.7500	- .0005	3.0000	- .0006	1.500	1.510	1/8	.060	1.7505	- .0005	1.7496	- .0005	3.0007	- .0007	3.0007	- .0007	39100	22400
MR-36	MI-28	MS 500072-25	1.7500		3.0000		1.750	1.760	1/8	.060	1.7505		1.7496		3.0007		3.0007		47400	26000
MR-36	MI-30		1.8750		3.0000		1.750	1.760	1/8	.060	1.8755		1.8746		3.0007		3.0007		47400	26000
MR-40-N	MI-32-N	MS 500072-27	2.0000		3.2500		1.500	1.510	1/8	.080	2.0005		1.9996		3.2496		3.2507		42900	23400
MR-40	MI-31	MS 500072-26	1.9375		3.2500		1.750	1.760	1/8	.080	1.9380		1.9371		3.2496		3.2507		52100	27200
MR-40	MI-32		2.0000		3.2500		1.750	1.760	1/8	.080	2.0005		1.9996		3.2507		3.2507		52100	27200
MR-40	MI-34		2.1250		3.2500		1.750	1.760	1/8	.080	2.1258		2.1247		3.2496		3.2507		52100	27200
MR-44-N	MI-36-N	MS 500072-29	2.2500		3.5000		1.500	1.510	1/8	.080	2.2508		2.2497		3.4995		3.5008		46700	24500
MR-44	MI-35	MS 500072-28	2.1875		3.5000		1.750	1.760	1/8	.080	2.1883		2.1872		3.4995		3.5008		56700	28400
MR-44	MI-36		2.2500		3.5000		1.750	1.760	1/8	.080	2.2508		2.2497		3.4995		3.5008		56700	28400
MR-48-N	MI-40-N	MS 500072-31	2.5000		3.7500		1.500	1.510	1/8	.080	2.5008		2.4997		3.7495		3.7508		52300	26100
MR-48	MI-38	MS 500072-30	2.3750		3.7500		1.750	1.760	1/8	.080	2.3758		2.3747		3.7495		3.7508		63400	30300
MR-48	MI-39		2.4375		3.7500		1.750	1.760	1/8	.080	2.4383		2.4372		3.7495		3.7508		63400	30300
MR-48	MI-40		2.5000		3.7500		1.750	1.760	1/8	.080	2.5008	- .0008	2.4997	- .0008	3.7495		3.7508		63400	30300
MR-52	MI-42		2.6250	- .0006	4.2500	- .0008	1.750	1.760	3/16	.080	2.6258		2.6247		4.2495	- .0010	4.2508	- .0010	64400	29900
MR-52	MI-44	MS 500072-32	2.7500		4.2500		1.750	1.760	3/16	.080	2.7508		2.7497		4.2495		4.2508		64400	29900
MR-56-N	MI-48-N		3.0000		4.5000		1.750	1.760	3/16	.080	3.0008		2.9997		4.4995		4.5008		71600	31300
MR-56	MI-46		2.8750		4.5000		2.000	2.010	3/16	.080	2.8758		2.8747		4.4995		4.5008		83500	35900
MR-56	MI-47	MS 500072-34	2.9375		4.5000		2.000	2.010	3/16	.080	2.9383		2.9372		4.4995		4.5008		83500	35900
MR-56	MI-48		3.0000		4.5000		2.000	2.010	3/16	.080	3.0008		2.9997		4.4995		4.5008		83500	35900
MR-60	MI-50	MS 500072-35	3.1250		4.7500		2.000	2.010	3/16	.100	3.1260		3.1246		4.7495		4.7508		87100	36500
MR-60	MI-52	MS 500072-36	3.2500		4.7500		2.000	2.010	3/16	.100	3.2510		3.2496		4.7495		4.7508		87100	36500
MR-64	MI-54	MS 500072-38	3.3750		5.0000		2.000	2.010	3/16	.100	3.3758		3.3746		4.9999		5.0011		93800	38000
MR-64	MI-56		3.5000		5.0000		2.000	2.010	3/16	.100	3.5008		3.4996		4.9999		5.0011		93800	38000
MR-68	MI-58		3.6250		5.2500		2.000	2.010	3/16	.100	3.6258		3.6246		5.2499		5.2511		101000	39500
MR-68	MI-60	MS 500072-40	3.7500		5.2500		2.000	2.010	3/16	.100	3.7508		3.7496		5.2499		5.2511		101000	39500
MR-72	MI-62		3.8750	- .0008	6.0000	- .0010	2.250	2.260	3/16	.100	3.8758		3.8746		5.9999		6.0011		130000	60300
MR-80	MI-64		4.0000		6.5000		2.250	2.260	3/16	.100	4.0008	- .0010	3.9996	- .0010	6.4999		6.5011		148000	64600
MR-80	MI-68		4.2500		6.5000		2.250	2.260	3/16	.100	4.2508		4.2496		6.4999		6.5011		148000	64600
MR-88-N	MI-72-N	MS 500072-43	4.5000		7.0000		2.500	2.515	3/16	.100	4.5008		4.4996		6.9999	- .0015	7.0011	- .0015	169800	70200
MR-88	MI-72	MS 500072-44	4.5000		7.0000		3.000	3.015	3/16	.100	4.5008		4.4996		6.9999		7.0011		220000	85700
MR-96-N	MI-80-N	MS 500072-46	5.0000		7.5000		2.500	2.515	1/4	.120	5.0010		4.9995		7.4998		7.5011		177000	71000
MR-96	MI-80	MS 500072-47	5.0000		7.5000		3.000	3.015	1/4	.120	5.0010		4.9995		7.4998		7.5011		228000	86600
MR-104-N	MI-88-N	MS 500072-48	5.5000		8.0000		2.500	2.515	1/4	.120	5.5010		5.4995		7.9998		8.0011		183000	71700
*MR-104	MI-88	MS 500072-49	5.5000		8.0000		3.000	3.015	1/4	.120	5.5010		5.4995		7.9998		8.0011		237000	87500
MR-116	MI-96	MS 500072-50	6.0000	- .0010	9.1250	- .0012	3.000	3.015	1/4	.120	6.0012		5.9995		9.1248		9.1261		234000	95200
*MR-124	MI-104		6.5000		9.6250		3.000	3.015	1/4	.120	6.5012		6.4995		9.6250		9.6265		252000	99100
*MR-132	MI-112		7.0000		10.1250		3.000	3.015	1/4	.120	7.0012	- .0012	6.9995	- .0012	10.1250		10.1265	- .0012	270000	103000
*MR-140	MI-120		7.5000		10.6250		3.000	3.015	1/4	.160	7.5010		7.4995		10.6250	- .0020	10.6265	- .0020	280000	104000
MR-148	MI-128		8.0000	- .0012	11.1250	- .0014	3.000	3.015	1/4	.160	8.0010		7.9995		11.1250		11.1265		292000	108000

*Not available from stock. Consult McGill Customer Service for availability.

MR SERIES

Outer ring and roller assembly without separable inner ring

The outer ring and roller assemblies (MR) shown in this table are for use without inner rings on a ground shaft for which a minimum hardness of 58 Rockwell "C" scale is recommended.

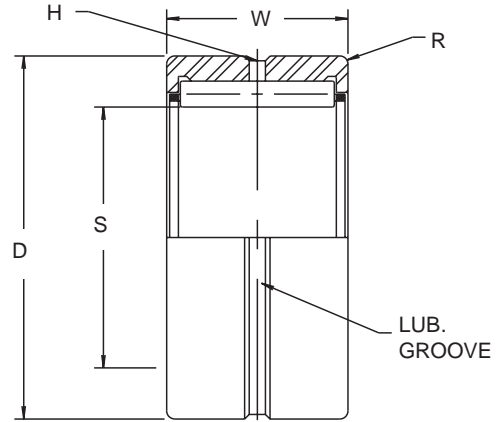

S equals shaft diameter

McGILL NUMBER outer ring & roller assy.	MILITARY STANDARD NUMBER	S SHAFT DIA.		D		W	H	R	HSG. BORE DIA.			STATIC LOAD RATING (LBS.)	BASIC DYNAMIC RATING (LBS.)	
		+ .0000	TOL.	+ .0000	TOL.	+ .000 - .005	HOLE DIA.	MAX. FILLET FOR HOUSING	ROTATING HOUSING	TOL. +.000-0	STATIONARY HOUSING			TOL. +.000-0
MR-10-N MR-10	MS 51961-1	.6250	-.0005	1.1250	-.0005	.750 1.000	5/64	.025	1.1247	-.0007	1.1257	-.0007	4300 6500	4320 5930
MR-12-N MR-12	MS 51961-2 MS 51961-3	.7500		1.2500		.750 1.000	5/64	.040	1.2497		1.2507		5400 8100	4990 6830
MR-14-N MR-14	MS 51961-5 MS 51961-6	.8750		1.3750		.750 1.000	5/64	.040	1.3747		1.3757		6000 9000	5280 7240
MR-16-N MR-16	MS 51961-8 MS 51961-9	1.0000		1.5000		.750 1.000	5/64	.040	1.4997		1.5007		7100 10600	5840 8000
MR-18-N MR-18	MS 51961-11 MS 51961-12	1.1250		1.6250		1.000 1.250	3/32	.040	1.6247		1.6257		12200 16300	8720 10900
MR-20-N MR-20	MS 51961-14 MS 51961-15	1.2500		1.7500		1.000 1.250	3/32	.040	1.7497		1.7507		13100 17500	9020 11300
MR-22-N MR-22	MS 51961-18 MS 51961-19	1.3750		1.8750		1.000 1.250	3/32	.040	1.8747		1.8757		14700 19700	9640 12100
MR-24-N MR-24	MS 51961-21 MS 51961-22	1.5000		2.0625		1.000 1.250	3/32	.060	2.0621		2.0632		15500 20800	10300 13000
MR-26-N MR-26	MS 51961-24 MS 51961-25	1.6250		2.1875		1.000 1.250	3/32	.060	2.1871		2.1882		16400 22100	10600 13300
MR-28-N MR-28	MS 51961-27 MS 51961-28	1.7500		2.3125		1.000 1.250	3/32	.060	2.3121		2.3132		18100 24400	11200 14100
MR-30-N MR-30	MS 51961-29	1.8750	2.4375	1.000 1.250	3/32	.060	2.4371	2.4382	19000 25600	11400 14400				
MR-31		1.9375	2.5000	1.250	3/32	.060	2.4996	2.5007	22400	12400				
MR-32-N MR-32	MS 51961-30	2.0000	2.5625	1.000 1.250	3/32	.060	2.5621	2.5632	20700 27900	12000 15200				
MR-36-N MR-36	MS 51961-31 MS 51961-32	2.2500	3.0000	1.500 1.750	1/8	.060	2.9996	3.0007	39100 47400	22400 26000				
MR-40-N MR-40	MS 51961-33 MS 51961-34	2.5000	3.2500	1.500 1.750	1/8	.080	3.2496	3.2507	42900 52100	23400 27200				
MR-44-N MR-44	MS 51961-35 MS 51961-36	2.7500	3.5000	1.500 1.750	1/8	.080	3.4995	3.5008	46700 56700	24500 28400				
MR-48-N MR-48	1961-37 MS 51961-38	3.0000	3.7500	1.500 1.750	1/8	.080	3.7495	3.7508	52300 63400	26100 30300				
MR-52	MS 51961-39	3.2500	4.2500	1.750	3/16	.080	4.2495	4.2508	64400	29900				
MR-56-N MR-56	MS 51961-41 MS 51961-42	3.5000	4.5000	1.750 2.000	3/16	.080	4.4995	4.5008	71600 83500	31300 35900				
MR-60	MS 51961-43	3.7500	4.7500	2.000	3/16	.100	4.7495	4.7508	87100	36500				
MR-64	MS 51961-45	4.0000	5.0000	2.000	3/16	.100	4.9999	5.0011	93800	38000				
MR-68	MS 51961-46	4.2500	5.2500	2.000	3/16	.100	5.2499	5.2511	101000	39500				
MR-72	MS 51961-48	4.5000	6.0000	2.250	3/16	.100	5.9999	6.0011	130000	60300				
MR-80		5.0000	6.5000	2.250	3/16	.100	6.4999	6.5011	148000	64600				
MR-88-N MR-88	MS 51961-52 MS 51961-53	5.5000	7.0000	2.500 3.000	3/16	.100	6.9999	7.0011	169800 222000	70200 85700				
MR-96-N MR-96	MS 51961-55 MS 51961-56	6.0000	7.5000	2.500 3.000	1/4	.120	7.4998	7.5011	177000 228000	71000 86600				
MR-104-N *MR-104	MS 51961-57 MS 51961-58	6.5000	8.0000	2.500 3.000	1/4	.120	7.9998	8.0011	183000 237000	71700 87500				
MR-116	MS 51961-59	7.2500	9.1250	3.000	1/4	.120	9.1248	9.1261	234000	95200				
*MR-124		7.7500	9.6250	3.000	1/4	.120	9.6250	9.6265	252000	99100				
*MR-132		8.2500	10.1250	3.000	1/4	.120	10.1250	10.1265	270000	103000				
*MR-140		8.7500	10.6250	3.000	1/4	.160	10.6250	10.6265	280000	104000				
MR-148		9.2500	11.1250	3.000	1/4	.160	11.1250	11.1265	292000	108000				

*Not available from stock. Consult McGill Customer Service for availability.

Outer ring and roller assembly with separable inner ring

Available in 5 seal combinations (see page 69 also)

For a complete bearing, specify both outer and inner, as each is packed and shipped separately. Consult McGill Engineering Department for additional information on CAGEROL® bearing sizes not listed as available with seals. The suffix "SS" indicates double seals with lips turned in (illustrated at right). This construction is most common and is intended primarily for lubrication retention. For other seal combinations, see page 69.

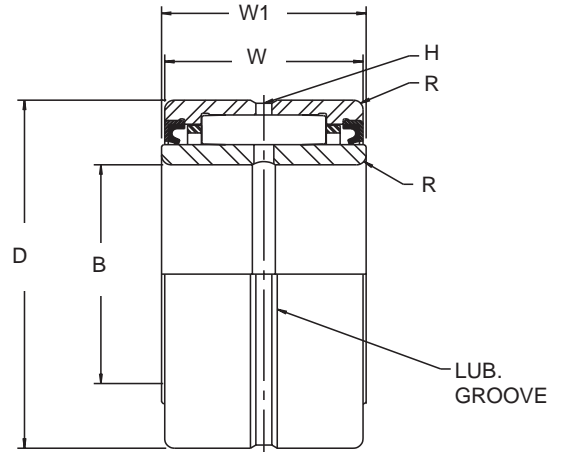

McGILL NUMBER outer ring & roller assy.	McGILL NUMBER inner ring only	B		D*		W	W1	H	R	SHAFT DIA.			HSG. BORE DIA.			STATIC LOAD RATING (LBS.)	BASIC DYNAMIC RATING (LBS.)		
		+0.000	TOL.	+0.000	TOL.	+0.000	+0.000	HOLE DIA.	MAX. FILLET for shaft & hsg.	ROTAT. SHAFT	TOL. +0.0000	STAT. SHAFT	TOL. +0.0000	ROTAT. HSG.	TOL. +0.0000			STAT. HSG.	TOL. +0.0000
MR-10-SS	MI-6	.3750		1.1250		1.000	1.010	5/64	.025	.3755		.3747		1.1247		1.1257		4300	4320
MR-12-SS	MI-8	.5000	-.0004	1.2500		1.000	1.010	5/64	.040	.5005		.4997		1.2497		1.2507		5400	4990
MR-14-SS	MI-10	.6250		1.3750		1.000	1.010	5/64	.040	.6255		.6247		1.3747		1.3757		6000	5280
MR-16-SS	MI-12 MI-13	.7500 .8125		1.5000 1.5000	-.0005	1.000 1.000	1.010 1.010	5/64	.040	.7505 .8129		.7497 .8121		1.4997 1.4997		1.5007 1.5007		7100 7100	5840 5840
MR-18-SS	MI-14 MI-15	.8750 .9375		1.6250 1.6250		1.250 1.250	1.260 1.260	3/32	.040	.8754 .9379		.8746 .9371		1.6247 1.6247		1.6257 1.6257		12200 12200	8720 8720
MR-20-SS	MI-16	1.0000		1.7500		1.250	1.260	3/32	.040	1.0004		.9996		1.7497		1.7507		13100	9020
MR-22-SS	MI-17 MI-18	1.0625 1.1250		1.8750 1.8750		1.250 1.250	1.260 1.260	3/32	.040	1.0630 1.1255		1.0621 1.1246		1.8747 1.8747		1.8757 1.8757		14700 14700	9640 9640
MR-24-SS	MI-19 MI-20	1.1875 1.2500		2.0625 2.0625		1.250 1.250	1.260 1.260	3/32	.060	1.1880 1.2505	-.0005	1.1871 1.2496	-.0005	2.0621 2.0621		2.0632 2.0632		15500 15500	10300 10300
MR-26-SS	MI-21 MI-22-4S	1.3125 2.1875	-.0005	2.1875 2.1875		1.250 1.250	1.260 1.260	3/32	.060	1.3130 1.3755		1.3121 1.3746		2.1871 2.1871	-.0007	2.1882 2.1882	-.0007	16400 16400	10600 10600
MR-28-SS	MI-22 MI-23 MI-24	1.3750 1.4375 1.5000		2.3125 2.3125 2.3125		1.250 1.250 1.250	1.260 1.260 1.260	3/32	.060	1.3755 1.4380 1.5005		1.3746 1.4371 1.4996		2.3121 2.3121 2.3121		2.3132 2.3132 2.3132		18100 18100 18100	11200 11200 11200
MR-30-SS	MI-25-4S	1.5625		2.4375	-.0006	1.250	1.260	3/32	.060	1.5630		1.5621		2.4371		2.4382		19000	11400
MR-32-SS	MI-25 MI-26 MI-27	1.5625 1.6250 1.6875		2.5625 2.5625 2.5625		1.250 1.250 1.250	1.260 1.260 1.260	3/32	.060	1.5630 1.6255 1.6880		1.5621 1.6246 1.6871		2.5621 2.5621 2.5621		2.5632 2.5632 2.5632		20700 20700 20700	12000 12000 12000
MR-36-SS	MI-28 MI-30	1.7500 1.8750		3.0000 3.0000		1.750 1.750	1.760 1.760	1/8	.060	1.7505 1.8755		1.7496 1.8746		2.9996 2.9996		3.0007 3.0007		39100 39100	22400 22400
MR-40-SS	MI-31 MI-32	1.9375 2.0000		3.2500 3.2500		1.750 1.750	1.760 1.760	1/8	.080	1.9380 2.0005		1.9371 1.9996		3.2496 3.2496		3.2507 3.2507		42900 42900	23400 23400
	MI-34	2.1250		3.2500		1.750	1.760			2.1258		2.1247		3.2496		3.2507		42900	23400
MR-44-SS	MI-35 MI-36	2.1875 2.2500		3.5000 3.5000		1.750 1.750	1.760 1.760	1/8	.080	2.1883 2.2508		2.1872 2.2497		3.4995 3.4995		3.5008 3.5008		46700 46700	24500 24500
MR-48-SS	MI-38 MI-39 MI-40	2.3750 2.4375 2.5000		3.7500 3.7500 3.7500		1.750 1.750 1.750	1.760 1.760 1.760	1/8	.080	2.3758 2.4383 2.5008	-.0008	2.3747 2.4372 2.4997	-.0008	3.7495 3.7495 3.7495		3.7508 3.7508 3.7508		52300 52300 52300	26100 26100 26100
†MR-52-SS	MI-42 MI-44	2.6250 2.7500	-.0006	4.2500 4.2500	-.0008	1.750 1.750	1.760 1.760	3/16	.080	2.6258 2.7508		2.6247 2.7497		4.2495 4.2495	-.0010	4.2508 4.2508	-.0010	54300 54300	25100 25100
MR-56-SS	MI-46 MI-47 MI-48	2.8750 2.9375 3.0000		4.5000 4.5000 4.5000		2.000 2.000 2.000	2.010 2.010 2.010	3/16	.080	2.8758 2.9383 3.0008		2.8747 2.9372 2.9997		4.4995 4.4995 4.4995		4.5008 4.5008 4.5008		71600 71600 71600	31300 31300 31300
†MR-60-SS	MI-50 MI-52	3.1250 3.2500		4.7500 4.7500		2.000 2.000	2.010 2.010	3/16	.100	3.1260 3.2510		3.1246 3.2496		4.7495 4.7495		4.7508 4.7508		74700 74700	31600 31600
†MR-64-SS	MI-54 MI-56	3.3750 3.5000		5.0000 5.0000		2.000 2.000	2.010 2.010	3/16	.100	3.3758 3.5008	-.0010	3.3746 3.4996	-.0010	4.9999 4.9999		5.0011 5.0011		80400 80400	32800 32800
†MR-68-SS	MI-58 MI-60	3.6250 3.7500	-.0008	5.2500 5.2500	-.0010	2.000 2.000	2.010 2.010	3/16	.100	3.6258 3.7508		3.6246 3.7496		5.2499 5.2499	-.0015	5.2511 5.2511	-.0015	86200 86200	34000 34000

† These sizes are not available from stock. Consult McGill Customer Service for availability.
* This dimension may be slightly oversize due to seal press fit.

CAGEROL®/GUIDEROL® Bearings

Outer ring and roller assembly without separable inner ring

Available in 5 seal combinations (see page 69 also)

The outer ring and roller assemblies are for use without inner rings on a ground shaft for which a minimum hardness of 58 Rockwell "C" scale is recommended. The suffix "SS" indicates double seals with lips turned in (illustrated at right). This construction is most common and is intended primarily for lubrication retention. For other seal combinations, see page 69.

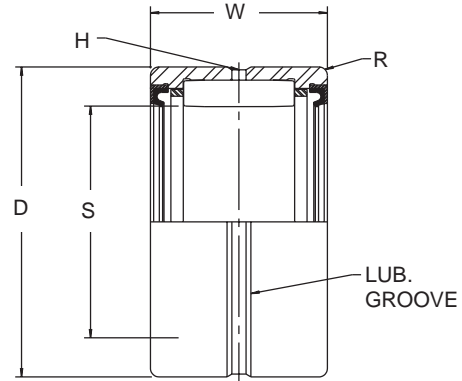

S equals shaft diameter

McGILL NUMBER outer ring & roller assy.	S SHAFT DIA.		D*		W	H	R	HSG. BORE DIA.			STATIC LOAD RATING (LBS.)	BASIC DYNAMIC RATING (LBS.)	
	+ .0000	TOL.	+ .0000	TOL.	+ .000 - .005	HOLE DIA.	MAX. FILLET FOR HOUSING	ROTATING HOUSING	TOL. + .0000	STATIONARY HOUSING			TOL. + .0000
MR-10-SS	.6250		1.1250		1.000	5/64	.025	1.1247		1.1257		4300	4320
MR-12-SS	.7500		1.2500		1.000	5/64	.040	1.2497		1.2507		5400	4990
MR-14-SS	.8750		1.3750		1.000	5/64	.040	1.3747		1.3757		6000	5280
MR-16-SS	1.0000		1.5000	-.0005	1.000	5/64	.040	1.4997		1.5007		7100	5840
MR-18-SS	1.1250		1.6250		1.250	3/32	.040	1.6247		1.6257		12200	8720
MR-20-SS	1.2500		1.7500		1.250	3/32	.040	1.7497		1.7507		13100	9020
MR-22-SS	1.3750		1.8750		1.250	3/32	.040	1.8747		1.8757		14700	9640
MR-24-SS	1.5000		2.0625		1.250	3/32	.060	2.0621	-.0007	2.0632	-.0007	15500	10300
MR-26-SS	1.6250		2.1875		1.250	3/32	.060	2.1871		2.1882		16400	10600
MR-28-SS	1.7500	-.0005	2.3125		1.250	3/32	.060	2.3121		2.3132		18100	11200
MR-30-SS	1.8750		2.4375	-.0006	1.250	3/32	.060	2.4371		2.4382		19000	11400
MR-32-SS	2.0000		2.5625		1.250	3/32	.060	2.5621		2.5632		20700	12000
MR-36-SS	2.2500		3.0000		1.750	1/8	.060	2.9996		3.0007		39100	22400
MR-40-SS	2.5000		3.2500		1.750	1/8	.080	3.2496		3.2507		42900	23400
MR-44-SS	2.7500		3.5000		1.750	1/8	.080	3.4995		3.5008		46700	24500
MR-48-SS	3.0000		3.7500		1.750	1/8	.080	3.7495		3.7508		52300	26100
†MR-52-SS	3.2500		4.2500	-.0008	1.750	3/16	.080	4.2495	-.0010	4.2508	-.0010	54300	25100
MR-56-SS	3.5000		4.5000		2.000	3/16	.080	4.4995		4.5008		71600	31300
†MR-60-SS	3.7500		4.7500		2.000	3/16	.100	4.7495		4.7508		74700	31600
†MR-64-SS	4.0000		5.0000		2.000	3/16	.100	4.9999		5.0011		80400	32800
†MR-68-SS	4.2500	-.0007	5.2500	-.0010	2.000	3/16	.100	5.2499	-.0015	5.2511	-.0015	86200	34000

† These sizes are not available from stock. Consult McGill Customer Service for availability.
 * This dimension may be slightly oversize due to seal press fit.

Seal operating information

Maximum peripheral shaft speed should not exceed 1000 feet per minute. Maximum operation temperature should not exceed 250°F. constant, 300°F. intermittent. Provision for lead or radius should be made on shaft corner to facilitate assembly of sealed bearings of the RS or SRS configuration. Venting of relubrication pressure is required to avoid displacement of seals in the S or SS configuration.

Other seal combinations and suffixes

Depending on the type of sealing to be accomplished, the seals for the SMR CAGEROL® Bearing may be applied to the bearing with the lips turned in or out or in combination. With single and double sealed bearings, this means five methods are possible. The arrangements are identified by adding the proper suffix to the standard CAGEROL® bearing number, as explained below.

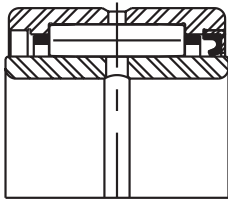

Suffix "S" indicates single seal with lip turned in. Normally, it would be used in conjunction with another sealed bearing on opposite end of shaft and would be intended for lubricant retention.

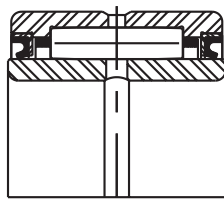

Suffix "RSS" is the designation for double-sealed bearing with both seal lips turned out. Primary function of "RSS" seals would be to help prevent entry of foreign material from either end.

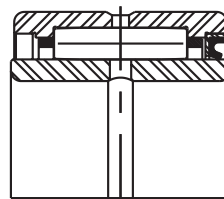

Suffix "RS" indicates single seal with lip turned out. Seal location would be intended primarily to help prevent entry of foreign material. Application is similar to that listed for "S" listings.

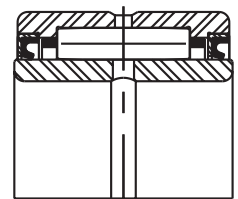

Suffix "SRS" indicates double seal with one lip turned in to retain lubricant and one turned out to help prevent entry of foreign material. Permits relubrication without displacing seal due to grease pressure.

Outer ring and roller assembly with separable inner ring

Outer ring and roller assemblies and associated inner rings are packed and shipped separately. For a complete bearing, specify both outer and inner numbers desired.

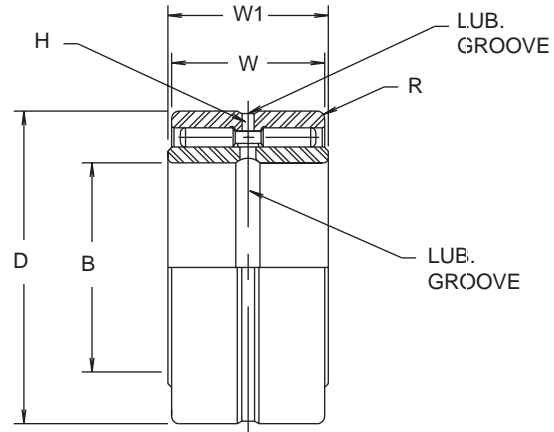

McGILL NUMBER outer ring & roller assy.	McGILL NUMBER inner ring only	ABMA NUMBER	B		D		W	W1	H	R	SHAFT DIA.				HSG. BORE DIA.				STATIC LOAD RATING (LBS.)	BASIC DYNAMIC RATING (LBS.)
			+ .0000	TOL.	+ .0000	TOL.	+ .00- 0 -.005	+ .00- 0 -.005	HOLE DIA.	MAX. FILLET for shaft & hsg.	ROTAT. SHAFT	TOL. + .0000- 0	STAT. SHAFT	TOL. + .0000	ROTAT. HSG.	TOL. + .0000	STAT. HSG.	TOL. + .0000		
GR-10-N	MI-6-N	6NAS1218	.3750	-.0004	1.1250	-.0005	.750	.760	5/64	.025	.3755	-.0005	.3747	-.0005	1.1247	-.0007	1.1257	-.0007	6400	3400
GR-10-N	MI-7-N	7NAS1218	.4375		1.1250		.750	.760	5/64	.025	.4380		.4372		1.1247		1.1257		6400	3400
GR-10	MI-6	6NAS1618	.3750		1.1250		1.000	1.010	5/64	.025	.3755		.3747		1.1247		1.1257		9100	4700
GR-12-N	MI-8-N	8NAS1220	.5000	-.0004	1.2500	-.0005	.750	.760	5/64	.040	.5005	-.0005	.4997	-.0005	1.2497	-.0007	1.2507	-.0007	7200	3700
GR-12-N	MI-9-N	9NAS1220	.5625		1.2500		.750	.760	5/64	.040	.5630		.5623		1.2497		1.2507		7200	3700
GR-12	MI-8	8NAS1620	.5000		1.2500		1.000	1.010	5/64	.040	.5005		.4997		1.2497		1.2507		10900	5100
GR-14-N	MI-10-N	10NAS1222	.6250	-.0004	1.3750	-.0005	.750	.760	5/64	.040	.6255	-.0005	.6247	-.0005	1.3747	-.0007	1.3757	-.0007	8400	4150
GR-14-N	MI-11-N	11NAS1222	.6875		1.3750		.750	.760	5/64	.040	.6880		.6872		1.3747		1.3757		8400	4150
GR-14	MI-10	10NAS1622	.6250		1.3750		1.000	1.010	5/64	.040	.6255		.6247		1.3747		1.3757		12800	5700
GR-16-N	MI-12-N	12NAS1224	.7500	-.0004	1.5000	-.0005	.750	.760	5/64	.040	.7505	-.0005	.7497	-.0005	1.4997	-.0007	1.5007	-.0007	9600	4350
GR-16-N	MI-13-N	13NAS1224	.8125		1.5000		.750	.760	5/64	.040	.8129		.8121		1.4997		1.5007		9600	4350
GR-16	MI-12	12NAS1624	.7500		1.5000		1.000	1.010	5/64	.040	.7505		.7497		1.4997		1.5007		14500	6050
GR-16	MI-13	13NAS1624	.8125	-.0004	1.5000	-.0005	1.000	1.010	5/64	.040	.8129	-.0005	.8121	-.0005	1.4997	-.0007	1.5007	-.0007	14500	6050
GR-18-N	MI-14-N	14NAS1626	.8750		1.6250		1.000	1.010	3/32	.040	.8754		.8746		1.6247		1.6257		15200	6250
GR-18-N	MI-15-N	15NAS1626	.9375		1.6250		1.000	1.010	3/32	.040	.9379		.9371		1.6247		1.6257		15200	6250
GR-18	MI-14	14NAS2026	.8750	-.0004	1.6250	-.0005	1.250	1.260	3/32	.040	.8754	-.0005	.8746	-.0005	1.6247	-.0007	1.6257	-.0007	20900	7900
GR-18	MI-15	15NAS2026	.9375		1.6250		1.250	1.260	3/32	.040	.9379		.9371		1.6247		1.6257		20900	7900
GR-18-N	MI-15-N	15NAS2026	.9375		1.6250		1.250	1.260	3/32	.040	.9379		.9371		1.6247		1.6257		20900	7900
GR-20-N	MI-16-N	16NAS1628	1.0000	-.0004	1.7500	-.0005	1.000	1.010	3/32	.040	1.0004	-.0005	.9996	-.0005	1.7497	-.0007	1.7507	-.0007	17000	6500
GR-20	MI-16	16NAS2028	1.0000		1.7500		1.250	1.260	3/32	.040	1.0004		.9996		1.7497		1.7507		23100	8300
GR-22-N	MI-18-N	18NAS1630	1.1250		1.8750		1.000	1.010	3/32	.040	1.1255		1.1246		1.8747		1.8757		18600	7100
GR-22	MI-17	17NAS2030	1.0625	-.0004	1.8750	-.0005	1.250	1.260	3/32	.040	1.0630	-.0005	1.0621	-.0005	1.8747	-.0007	1.8757	-.0007	25500	9050
GR-22	MI-18	18NAS2030	1.1250		1.8750		1.250	1.260	3/32	.040	1.1255		1.1246		1.8747		1.8757		25500	9050
GR-24-N	MI-20-N	20NAS1633	1.2500		2.0625		1.000	1.010	3/32	.060	1.2505		1.2496		2.0621		2.0632		20200	7150
GR-24	MI-19	19NAS2033	1.1875	-.0004	2.0625	-.0005	1.250	1.260	3/32	.060	1.1880	-.0005	1.1871	-.0005	2.0621	-.0007	2.0632	-.0007	27800	9150
GR-24	MI-20	20NAS2033	1.2500		2.0625		1.250	1.260	3/32	.060	1.2505		1.2496		2.0621		2.0632		27800	9150
GR-26-N	MI-21-N	21NAS1635	1.3125		2.1875		1.000	1.010	3/32	.060	1.3130		1.3121		2.1871		2.1882		21700	7500
GR-26	MI-21	21NAS2035	1.3125	-.0004	2.1875	-.0005	1.250	1.260	3/32	.060	1.3130	-.0005	1.3121	-.0005	2.1871	-.0007	2.1882	-.0007	29800	9600
GR-26	MI-22-4S	21NAS2035	1.3750		2.1875		1.250	1.260	3/32	.060	1.3755		1.3746		2.1871		2.1882		29800	9600
GR-28	MI-22	22NAS2037	1.3750		2.3125		1.250	1.260	3/32	.060	1.3755		1.3746		2.3121		2.3132		32100	9850
GR-28	MI-23	23NAS2037	1.4375	-.0004	2.3125	-.0005	1.250	1.260	3/32	.060	1.4380	-.0005	1.4371	-.0005	2.3121	-.0007	2.3132	-.0007	32100	9850
GR-28	MI-24	24NAS2037	1.5000		2.3125		1.250	1.260	3/32	.060	1.5005		1.4996		2.3121		2.3132		32100	9850

McGILL NUMBER outer ring & roller assy.	McGILL NUMBER inner ring only	ABMA NUMBER	B		D		W	W1	H	R	SHAFT DIA.			HSG. BORE DIA.				STATIC LOAD RATING (LBS.)	BASIC DYNAMIC RATING (LBS.)	
			+.0000	TOL.	+.0000	TOL.	+.000	+.000	HOLE DIA.	MAX. FILLET for shaft & hsg.	ROTAT. SHAFT	TOL. +.0000	STAT. SHAFT	TOL. +.0000	ROTAT. HSG.	TOL. +.0000	STAT. HSG.			TOL. +.0000
GR-30	MI-25-4S	25NAS2039	1.5625		2.4375		1.250	1.260	3/32	.060	1.5630		1.5621		2.4371		2.4382		34600	10450
GR-32-N	MI-26-N	26NAS1641	1.6250		2.5625		1.000	1.010	3/32	.060	1.6255		1.6246		2.5621		2.5632		26700	8000
GR-32	MI-25	25NAS2041	1.5625		2.5625		1.250	1.260	3/32	.060	1.5630		1.5621		2.5621		2.5632		36700	10250
GR-32	MI-26	26NAS2041	1.6250		2.5625		1.250	1.260	3/32	.060	1.6255		1.6246		2.5621		2.5632		36700	10250
GR-32	MI-27	27NAS2041	1.6875		2.5625		1.250	1.260	3/32	.060	1.6880		1.6871		2.5621		2.5632		36700	10250
GR-36-N	MI-28-N	28NAS2448	1.7500	-.0005	3.0000	-.0006	1.500	1.510	1/8	.060	1.7505	-.0005	1.7496	-.0005	2.9996	-.0007	3.0007	-.0007	49100	15250
GR-36	MI-28	28NAS2848	1.7500		3.0000		1.750	1.760	1/8	.060	1.7505		1.7496		2.9996		3.0007		60200	18450
GR-36	MI-30	30NAS2848	1.8750		3.0000		1.750	1.760	1/8	.060	1.8755		1.8746		2.9996		3.0007		60200	18450
GR-40-N	MI-32-N	32NAS2452	2.0000		3.2500		1.500	1.510	1/8	.080	2.0005		1.9996		3.2496		3.2507		54500	16200
GR-40	MI-31	31NAS2852	1.9375		3.2500		1.750	1.760	1/8	.080	1.9380		1.9371		3.2496		3.2507		66800	19800
GR-40	MI-32	32NAS2852	2.0000		3.2500		1.750	1.760	1/8	.080	2.0005		1.9996		3.2496		3.2507		66800	19800
GR-40	MI-34	34NAS2852	2.1250		3.2500		1.750	1.760	1/8	.080	2.1258		2.1247		3.2496		3.2507		66800	19800
GR-44-N	MI-36-N	36NAS2546	2.2500		3.5000		1.500	1.510	1/8	.080	2.2508		2.2497		3.4995		3.5008		59900	16800
GR-44	MI-35	35NAS2856	2.1875		3.5000		1.750	1.760	1/8	.080	2.1883		2.1872		3.4995		3.5008		73400	20350
GR-44	MI-36	36NAS2856	2.2500		3.5000		1.750	1.760	1/8	.080	2.2508		2.2497		3.4995		3.5008		73400	20350
GR-48-N	MI-40-N	40NAS2460	2.5000		3.7500		1.500	1.510	1/8	.080	2.5008		2.4997		3.7495		3.7508		65400	17350
GR-48	MI-38	38NAS2860	2.3750		3.7500		1.750	1.760	1/8	.080	2.3758		2.3747		3.7495		3.7508		80200	20600
GR-48	MI-39	39NAS2860	2.4375		3.7500		1.750	1.760	1/8	.080	2.4383		2.4372		3.7495		3.7508		80200	20600
GR-48	MI-40	40NAS2860	2.5000	-.0006	3.7500	-.0008	1.750	1.760	1/8	.080	2.5008	-.0008	2.4997	-.0008	3.7495		3.7508		80200	20600
GR-52	MI-42	42NAS2868	2.6250		4.2500		1.750	1.760	3/16	.080	2.6258		2.6247		4.2495	-.0010	4.2508	-.0010	80100	23950
GR-52	MI-44	44NAS2868	2.7500		4.2500		1.750	1.760	3/16	.080	2.7508		2.7497		4.2495		4.2508		80100	23950
GR-56-N	MI-48-N	48NAS2872	3.0000		4.5000		1.750	1.760	3/16	.080	3.0008		2.9997		4.4995		4.5008		86500	25100
GR-56	MI-46	46NAS3272	2.8750		4.5000		2.000	2.010	3/16	.080	2.8758		2.8747		4.4995		4.5008		104000	28900
GR-56	MI-47	47NAS3272	2.9375		4.5000		2.000	2.010	3/16	.080	2.9383		2.9372		4.4995		4.5008		104000	28900
GR-56	MI-48	48NAS3272	3.0000		4.5000		2.000	2.010	3/16	.080	3.0008		2.9997		4.4995		4.5008		104000	28900
GR-60	MI-50	50NAS3276	3.1250		4.7500		2.000	2.010	3/16	.100	3.1260		3.1246		4.7495		4.7508		111000	29300
GR-60	MI-52	52NAS3276	3.2500		4.7500		2.000	2.010	3/16	.100	3.2510		3.2496		4.7495		4.7508		111000	29300
GR-64	MI-54	54NAS3280	3.3750		5.0000		2.000	2.010	3/16	.100	3.3758		3.3746		4.9999		5.0011		119000	30100
GR-64	MI-56	56NAS3280	3.5000		5.0000		2.000	2.010	3/16	.100	3.5008		3.4996		4.9999		5.0011		119000	30100
GR-68	MI-58	58NAS3284	3.6250		5.2500		2.000	2.010	3/16	.100	3.6258		3.6246		5.2499		5.2511		126000	31500
GR-68	MI-60	60NAS3284	3.7500	-.0008	5.2500	-.0010	2.000	2.010	3/16	.100	3.7508	-.0010	3.7496	-.0010	5.2499		5.2511		126000	31500
GR-72	MI-62	62NAS3696	3.8750		6.0000		2.250	2.260	1/4	.100	3.8758		3.8746		5.9999		6.0011		145000	43400
GR-80	MI-64	64NAS36104	4.0000		6.5000		2.250	2.260	1/4	.100	4.0008	-.0010	3.9996	-.0010	6.4999		6.5011		161000	48800
GR-80	MI-68	68NAS36104	4.2500		6.5000		2.250	2.260	1/4	.100	4.2508		4.2496		6.4999		6.5011		161000	48800
GR-88-N	MI-72-N	72NAS40112	4.5000		7.0000		2.500	2.515	1/4	.100	4.5008		4.4996		6.9999	-.0015	7.0011	-.0015	171000	60700
GR-88	MI-72	72NAS48112	4.5000		7.0000		3.000	3.015	1/4	.100	4.5008		4.4996		6.9999		7.0011		205000	65000
GR-96-N	MI-80-N	80NAS40120	5.0000		7.5000		2.500	2.515	1/4	.120	5.0010		4.9995		7.4998		7.5011		223000	65700
GR-96	MI-80	80NAS48120	5.0000		7.5000		3.000	3.015	1/4	.120	5.0010		4.9995		7.4998		7.5011		283000	71400
GR-104-N	MI-88-N	88NAS40128	5.5000		8.0000		2.500	2.515	1/4	.120	5.5010		5.4995		7.9998		8.0011		242000	68900
GR-104	MI-88	88NAS48128	5.5000	-.0010	8.0000	-.0012	3.000	3.015	1/4	.120	5.5010	-.0010	5.4995	-.0010	7.9998		8.0011		308000	75000
GR-116	MI-96	96NAS48146	6.0000		9.1250		3.000	3.015	1/4	.120	6.0012		5.9995		9.1248		9.1261		332000	83900
GR-124	MI-104	104NAS48154	6.5000		9.6250		3.000	3.015	1/4	.120	6.5012		6.4995		9.6250		9.6265		355000	86200
GR-132	MI-112	112NAS48162	7.0000		10.1250		3.000	3.015	1/4	.120	7.0012	-.0012	6.9995	-.0012	10.1250	-.0020	10.1265	-.0020	378000	88700
GR-140	MI-120	120NAS48170	7.5000	-.0012	10.6250	-.0014	3.000	3.015	1/4	.160	7.5010		7.4995		10.6250		10.6265		401000	91500
GR-148	MI-128	128NAS48170	8.0000		11.1250		3.000	3.015	1/4	.160	8.0010		7.9995		11.1250		11.1265		423000	93500

CAGEROL®/GUIDEROL® Bearings

Outer ring and roller assembly without separable inner ring

The outer ring and roller assemblies (GR) shown in this table are for use without inner rings on a ground shaft for which a minimum hardness of 58 Rockwell "C" scale is recommended.

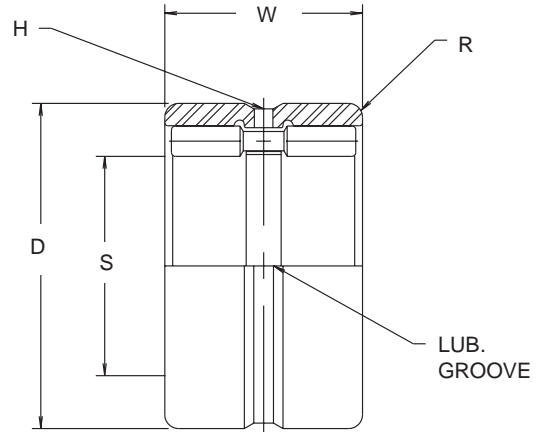

McGILL NUMBER outer ring & roller assy.	ABMA NUMBER	S SHAFT DIA.		D		W	H	R	HSG. BORE DIA.			STATIC LOAD RATING (LBS.)	BASIC DYNAMIC RATING (LBS.)	
		+0.000	TOL.	+0.000	TOL.	+0.000 -0.005	HOLE DIA.	MAX. FILLET FOR HOUSING	ROTATING HOUSING	TOL. +0.000	STATIONARY HOUSING			TOL. +0.000
GR-8-N	8NAR1216	.5000	-.0005	1.0000	-.0005	.750	5/64	.025	.9997	-0.0007	1.0007	-0.0007	4500	2600
GR-10-N	10NAR1218	.6250		1.1250		.750	5/64	.025	1.1247		1.1257		6400	3400
GR-10	10NAR1618	.6250		1.1250		1.000	5/64	.025	1.1247		1.1257		9100	4700
GR-12-N	12NAR1220	.7500		1.2500		.750	5/64	.040	1.2497		1.2507		7200	3700
GR-12	12NAR1620	.7500		1.2500		1.000	5/64	.040	1.2497		1.2507		10900	5100
GR-14-N	14NAR1222	.8750		1.3750		.750	5/64	.040	1.3747		1.3757		8400	4150
GR-14	14NAR1622	.8750		1.3750		1.000	5/64	.040	1.3747		1.3757		12800	5700
GR-16-N	16NAR1224	1.0000		1.5000		.750	5/64	.040	1.4997		1.5007		9600	4350
GR-16	16NAR1624	1.0000		1.5000		1.000	5/64	.040	1.4997		1.5007		14500	6050
GR-18-N	18NAR1626	1.1250		1.6250		1.000	3/32	.040	1.6247		1.6257		15200	6250
GR-18	18NAR2026	1.1250		1.6250		1.250	3/32	.040	1.6247		1.6257		20900	7900
GR-20-N	20NAR1628	1.2500		1.7500		1.000	3/32	.040	1.7497		1.7507		17000	6500
GR-20	20NAR2028	1.2500		1.7500		1.250	3/32	.040	1.7497		1.7507		23100	8300
GR-22-N	22NAR1630	1.3750		1.8750		1.000	3/32	.040	1.8747		1.8757		18600	7100
GR-22	22NAR2030	1.3750		1.8750		1.250	3/32	.040	1.8747		1.8757		25500	9050
GR-24-N	24NAR1633	1.5000		2.0625		1.000	3/32	.060	2.0621		2.0632		20200	7150
GR-24	24NAR2033	1.5000		2.0625		1.250	3/32	.060	2.0621		2.0632		27800	9150
GR-26-N	26NAR1635	1.6250		2.1875		1.000	3/32	.060	2.1871		2.1882		21700	7500
GR-26	26NAR2035	1.6250		2.1875		1.250	3/32	.060	2.1871		2.1882		29800	9600
GR-28	28NAR2037	1.7500		2.3125		1.250	3/32	.060	2.3121		2.3132		32100	9850
GR-30	30NAR2039	1.8750	2.4375	1.250	3/32	.060	2.4371	2.4382	34600	10450				
GR-32-N	32NAR1641	2.0000	2.5625	1.000	3/32	.060	2.5621	2.5632	26700	8000				
GR-32	32NAR2041	2.0000	2.5625	1.250	3/32	.060	2.5621	2.5632	36700	10250				
GR-36-N	36NAR2448	2.2500	3.0000	1.500	1/8	.060	2.9996	3.0007	49100	15250				
GR-36	36NAR2848	2.2500	3.0000	1.750	1/8	.060	2.9996	3.0007	60200	18450				
GR-40-N	40NAR2452	2.5000	3.2500	1.500	1/8	.080	3.2496	3.2507	54500	16200				
GR-40	40NAR2852	2.5000	3.2500	1.750	1/8	.080	3.2496	3.2507	66800	19800				
GR-44-N	44NAR2456	2.7500	3.5000	1.500	1/8	.080	3.4995	3.5008	59900	16800				
GR-44	44NAR2856	2.7500	3.5000	1.750	1/8	.080	3.4995	3.5008	73400	20350				
GR-48-N	48NAR2460	3.0000	3.7500	1.500	1/8	.080	3.7495	3.7508	65400	17350				
GR-48	48NAR2860	3.0000	3.7500	1.750	1/8	.080	3.7495	3.7508	80200	20600				
GR-52	52NAR2868	3.2500	4.2500	1.750	3/16	.080	4.2495	4.2508	80100	23950				
GR-56-N	56NAR2872	3.5000	4.5000	1.750	3/16	.080	4.4995	4.5008	86500	25100				
GR-56	56NAR3272	3.5000	4.5000	2.000	3/16	.080	4.4995	4.5008	104000	28900				
GR-60	60NAR3276	3.7500	4.7500	2.000	3/16	.100	4.7495	4.7508	111000	29300				
GR-64	64NAR3280	4.0000	5.0000	2.000	3/16	.100	4.9999	5.0011	119000	30900				
GR-68	68NAR3284	4.2500	5.2500	2.000	3/16	.100	5.2499	5.2511	126000	31500				
GR-72	72NAR3696	4.5000	6.0000	2.250	1/4	.100	5.9999	6.0011	145000	43400				
GR-80	80NAR36104	5.0000	6.5000	2.250	1/4	.100	6.4999	6.5011	161000	48800				
GR-88-N	88NAR40112	5.5000	7.0000	2.500	1/4	.100	6.9999	7.0011	171000	60700				
GR-88	88NAR48112	5.5000	7.0000	3.000	1/4	.100	6.9999	7.0011	205000	65000				
GR-96-N	96NAR40120	6.0000	7.5000	2.500	1/4	.120	7.4998	7.5011	223000	65700				
GR-96	96NAR48120	6.0000	7.5000	3.000	1/4	.120	7.4998	7.5011	283000	71400				
GR-104-N	104NAR40128	6.5000	8.0000	2.500	1/4	.120	7.9998	8.0011	242000	68900				
GR-104	104NAR48128	6.5000	8.0000	3.000	1/4	.120	7.9998	8.0011	308000	75000				
GR-116	116NAR48146	7.2500	9.1250	3.000	1/4	.120	9.1248	9.1261	332000	83900				
GR-124	124NAR48154	7.7500	9.6250	3.000	1/4	.120	9.6250	9.6265	355000	86200				
GR-132	132NAR48162	8.2500	10.1250	3.000	1/4	.120	10.1250	10.1265	378000	88700				
GR-140	140NAR48170	8.7500	10.6250	3.000	1/4	.160	10.6250	10.6265	401000	91500				
GR-148	148NAR48178	9.2500	11.1250	3.000	1/4	.160	11.1250	11.1265	423000	93500				

NOTE: Some larger sizes not available from stock. Consult McGill Customer Service for availability.

Outer ring and roller assembly with separate inner ring

Available in 5 seal combinations (see page 75 also)

For a complete bearing, specify both outer and inner, as each is packed and shipped separately. Consult McGill Engineering Department for additional information on GUIDEROL® bearing sizes not listed as available with seals. The suffix "SS" indicates double seals with lips turned in (illustrated at right). This construction is most common and is intended primarily for lubrication retention. For other seal combinations, see page 75.

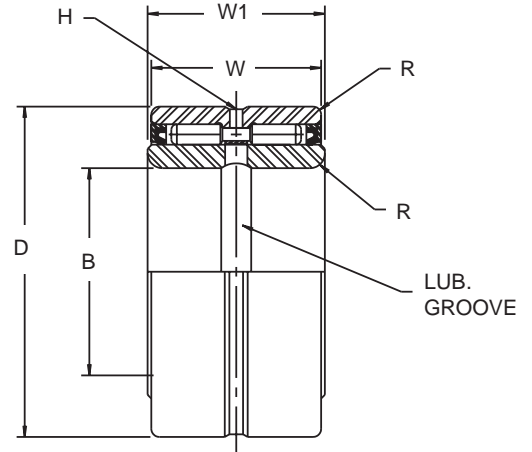

McGILL NUMBER outer ring & roller assy.	McGILL NUMBER inner ring only	B		D*		W	W1	H	R	SHAFT DIA.				HSG. BORE DIA.				STATIC LOAD RATING (LBS.)	BASIC DYNAMIC RATING (LBS.)
		+ .0000	TOL.	+ .0000	TOL.	+ .0000 -.0005	+ .0000 -.0005	HOLE DIA.	MAX. FILLET for shaft & hsg.	ROTAT. SHAFT	TOL. + .0000	STAT. SHAFT	TOL. + .0000	ROTAT. HSG.	TOL. + .0000	STAT. HSG.	TOL. + .0000		
GR-10-SS	MI-6	.3750		1.1250		1.000	1.010	5/64	.025	.3755		.3747		1.1247		1.1257		6400	3400
GR-12-SS	MI-8	.5000	-.0004	1.2500		1.000	1.010	5/64	.040	.5005		.4997		1.2497		1.2497		7200	3700
GR-14-SS	MI-10	.6250		1.3750		1.000	1.010	5/64	.040	.6255		.6247		1.3747		1.3757		8400	4150
GR-16-SS	MI-12	.7500		1.5000		1.000	1.010	5/64	.040	.7505		.7497		1.4997		1.5007		9600	4350
GR-18-SS	MI-14	.8750		1.6250	-.0005	1.250	1.260	3/32	.040	.8754		.8746		1.6247		1.6257		15200	6250
	MI-15	.9375		1.6250		1.250	1.260	3/32	.040	.9379		1.6247		1.6257		15200		6250	
GR-20-SS	MI-16	1.0000		1.7500		1.250	1.260	3/32	.040	1.0004		.9996		1.7497		1.7507		17000	6500
GR-22-SS	MI-17	1.0625		1.8750		1.250	1.260	3/32	.040	1.0630		1.0621		1.8747		1.8757		18600	7100
	MI-18	1.1250		1.8750		1.250	1.260	3/32	.040	1.1255		1.8747		1.8757		18600		7100	
GR-24-SS	MI-19	1.1875		2.0625		1.250	1.260	3/32	.060	1.1880	-.0005	1.1871	-.0005	2.0621	-.0007	2.0632	-.0007	20200	7150
	MI-20	1.2500		2.0625		1.250	1.260	3/32	.060	1.2505		2.0621		2.0632		20200		7150	
GR-26-SS	MI-21	1.3125		2.1875		1.250	1.260	3/32	.060	1.3130		1.3121		2.1882		2.1882		21700	7500
	MI-22-4S	1.3750		2.1875		1.250	1.260	3/32	.060	1.3755		2.1871		2.1882		21700		7500	
GR-28-SS	MI-22	1.3750	-.0005	2.3125		1.250	1.260	3/32	.060	1.3755		1.3746		2.3121		2.3132		23300	7750
	MI-23	1.4375		2.3125		1.250	1.260	3/32	.060	1.4380		2.3121		2.3132		23300		7750	
	MI-24	1.5000		2.3125		1.250	1.260	3/32	.060	1.5005		2.3121		2.3132		23300		7750	
GR-30-SS	MI-25-4S	1.5625		2.4375		1.250	1.260	3/32	.060	1.5630		1.5621		2.4371		2.4382		25200	8150
GR-32-SS	MI-25	1.5625		2.5625	-.0006	1.250	1.260	3/32	.060	1.5630		1.5621		2.5621		2.5632		26700	8000
	MI-26	1.6250		2.5625		1.250	1.260	3/32	.060	1.6255		2.5621		2.5632		26700		8000	
	MI-27	1.6875		2.5625		1.250	1.260	3/32	.060	1.6880		2.5621		2.5632		26700		8000	
GR-36-SS	MI-28	1.7500		3.0000		1.750	1.760	1/8	.060	1.7505		1.7496		2.9996		3.0007		49100	15250
	MI-30	1.8750		3.0000		1.750	1.760	1/8	.060	1.8755		2.9996		3.0007		49100		15250	
GR-40-SS	MI-31	1.9375		3.2500		1.750	1.760	1/8	.080	1.9380		1.9371		3.2496		3.2507		54500	16200
	MI-32	2.0000		3.2500		1.750	1.760	1/8	.080	2.0005		3.2496		3.2507		54500		16200	
	MI-34	2.1250		3.2500		1.750	1.760	1/8	.080	2.1258		3.2496		3.2507		54500		16200	
GR-44-SS	MI-35	2.1875		3.5000		1.750	1.760	1/8	.080	2.1883		2.1874		3.4995		3.5008		59900	16800
	MI-36	2.2500		3.5000		1.750	1.760	1/8	.080	2.2508		3.4995		3.5008		59900		16800	
GR-48-SS	MI-38	2.3750		3.7500		1.750	1.760	1/8	.080	2.3758		2.3747		3.7495		3.7508		65400	17350
	MI-39	2.4375		3.7500		1.750	1.760	1/8	.080	2.4383		3.7495		3.7508		65400		17350	
	MI-40	2.5000		3.7500		1.750	1.760	1/8	.080	2.5008		3.7495		3.7508		65400		17350	
GR-52-SS	MI-42	2.6250	-.0006	4.2500	-.0008	1.750	1.760	3/16	.080	2.6258		2.6247	-.0008	4.2495	-.0010	4.2508	-.0010	63800	20050
	MI-44	2.7500		4.2500		1.750	1.760	3/16	.080	2.7508		4.2495		4.2508		63800		20050	
GR-56-SS	MI-46	2.8750		4.5000		2.000	2.010	3/16	.080	2.8758		2.8747		4.4995		4.5008		86500	25100
	MI-47	2.9375		4.5000		2.000	2.010	3/16	.080	2.9383		4.4995		4.5008		86500		25100	
	MI-48	3.0000		4.5000		2.000	2.010	3/16	.080	3.0008		4.4995		4.5008		86500		25100	
GR-60-SS	MI-50	3.1250		4.7500		2.000	2.010	3/16	.100	3.1260		3.1246		4.7495		4.7508		92300	25450
	MI-52	3.2500		4.7500		2.000	2.010	3/16	.100	3.2510		4.7495		4.7508		92300		25450	
GR-64-SS	MI-54	3.3750		5.0000		2.000	2.010	3/16	.100	3.3758	-.0010	3.3746	-.0010	4.9999	-.0015	5.0011	-.0015	98800	26750
	MI-56	3.5000		5.0000		2.000	2.010	3/16	.100	3.5008		4.9999		5.0011		98800		26750	
GR-68-SS	MI-58	3.6250	-.0008	5.2500	-.0010	2.000	2.010	3/16	.100	3.6258		3.6246		5.2499		5.2511		104000	27400
	MI-60	3.7500		5.2500		2.000	2.010	3/16	.100	3.7508		5.2499		5.2511		104000		27400	

* This dimension may be slightly oversize due to seal press fit.

Outer ring and roller assembly without separable inner ring

Available in 5 seal combinations (see page 75 also)

The outer ring and roller assemblies are for use without inner rings on a ground shaft for which a minimum hardness of 58 Rockwell "C" scale is recommended. The suffix "SS" indicates double seals with lips turned in (illustrated at right). This construction is most common and is intended primarily for lubrication retention. For other seal combinations, see page 75.

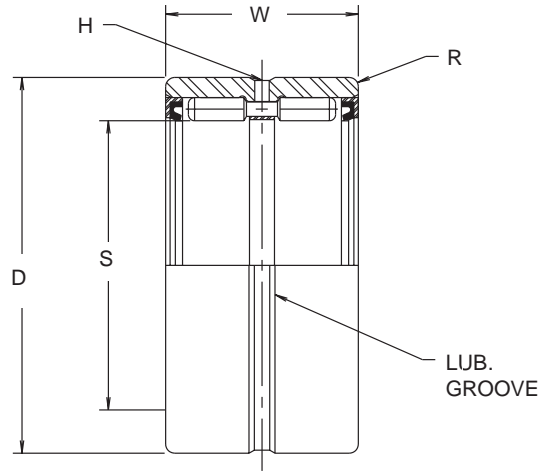

McGILL NUMBER outer ring & roller assy.	S SHAFT DIA.		D*		W	H	R	HSG. BORE DIA.			STATIC LOAD RATING (LBS.)	BASIC DYNAMIC RATING (LBS.)	
	+ .0000	TOL.	+ .0000	TOL.	+ .000 - .005	HOLE DIA.	MAX. FILLET FOR HOUSING	ROTATING HOUSING	TOL. + .0000	STATIONARY HOUSING			TOL. + .0000
GR-10-SS	.6250		1.1250		1.000	5/64	.025	1.1247		1.1257		6400	3400
GR-12-SS	.7500		1.2500		1.000	5/64	.040	1.2497		1.2507		7200	3700
GR-14-SS	.8750		1.3750		1.000	5/64	.040	1.3747		1.3757		8400	4150
GR-16-SS	1.0000		1.5000	-.0005	1.000	5/64	.040	1.4997		1.5007		9600	4350
GR-18-SS	1.1250		1.6250		1.250	3/32	.040	1.6247		1.6257		15200	6250
GR-20-SS	1.2500		1.7500		1.250	3/32	.040	1.7497		1.7507		17000	6500
GR-22-SS	1.3750		1.8750		1.250	3/32	.040	1.8747		1.8757		18600	7100
GR-24-SS	1.5000		2.0625		1.250	3/32	.060	2.0621		2.0632		20200	7150
GR-26-SS	1.6250		2.1875		1.250	3/32	.060	2.1871		2.1882		21700	7500
GR-28-SS	1.7500	-.0005	2.3125		1.250	3/32	.060	2.3121		2.3132		23300	7750
GR-30-SS	1.8750		2.4375	-.0006	1.250	3/32	.060	2.4371		2.4382		25200	8150
GR-32-SS	2.0000		2.5625		1.250	3/32	.060	2.5621		2.5632		26700	8000
GR-36-SS	2.2500		3.0000		1.750	1/8	.060	2.9996		3.0007		49100	15250
GR-40-SS	2.5000		3.2500		1.750	1/8	.080	3.2496		3.2507		54500	16200
GR-44-SS	2.7500		3.5000		1.750	1/8	.080	3.4995		3.5008		59900	16800
GR-48-SS	3.0000		3.7500		1.750	1/8	.080	3.7495		3.7508		65400	17350
GR-52-SS	3.2500		4.2500	-.0008	1.750	3/16	.080	4.2495		4.2508	-.0010	63800	20050
GR-56-SS	3.5000		4.5000		2.000	3/16	.080	4.4995		4.5008		86500	25100
GR-60-SS	3.7500		4.7500		2.000	3/16	.100	4.7495		4.7508		92300	25450
GR-64-SS	4.0000		5.0000		2.000	3/16	.100	4.9999		5.0011		98800	26750
GR-68-SS	4.2500	-.0007	5.2500	-.0010	2.000	3/16	.100	5.2499	-.0015	5.2511	-.0015	104000	27400

* This dimension may be slightly oversized due to seal press fit.

Seal operating information

Maximum peripheral shaft speed should not exceed 1000 feet per minute. Maximum operation temperature should not exceed 250°F. constant, 300°F. intermittent. Provision for lead or radius should be made on shaft corner to facilitate assembly of sealed bearings of the RS or SRS configuration. Venting of relubrication pressure is required to avoid displacement of seals in the S or SS configuration.

Other seal combinations and suffixes

Depending on the type of sealing to be accomplished, the seals for the SG GUIDEROL® Bearing may be applied to the bearing with the lips turned in or out or in combination. With single and double sealed bearings, this means five methods are possible. The arrangements are identified by adding the proper suffix to the standard GUIDEROL® bearing number, as explained below.

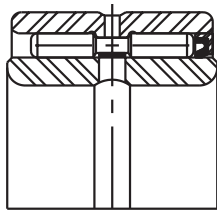

Suffix "S" indicates single seal with lip turned in. Normally, it would be used in conjunction with another sealed bearing on opposite end of shaft and would be intended for lubricant retention.

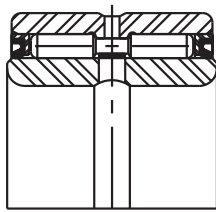

Suffix "RSS" is the designation for double-sealed bearing with both seal lips turned out. Primary function of "RSS" seals would be to help prevent entry of foreign material from either end.

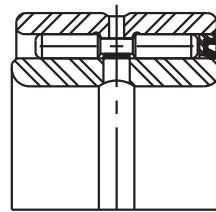

Suffix "RS" indicates single seal with lip turned out. Seal location would be intended primarily to help prevent entry of foreign material. Application is similar to that listed for "S" listings.

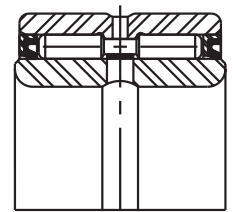

Suffix "SRS" indicates double seal with one lip turned in to retain lubricant and one turned out to help prevent entry of foreign material. Permits relubrication without displacing seal due to grease pressure.

MI INNER RACES

McGILL® MI series inner races, as shown in preceding pages with outer race and roller assemblies, are repeated below for convenience of application as hardened and ground steel bushings or sleeves. They are complete with radial oil holes and annular lubrication grooves. Inner races of special configurations and materials are available on special order to suit individual requirements.

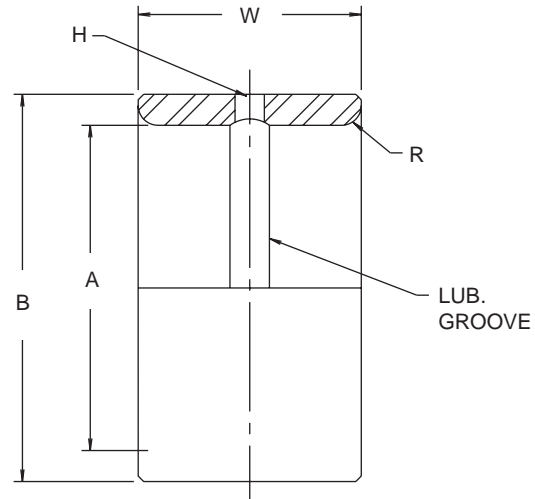

McGILL INNER RING NUMBER	MILITARY STANDARD NUMBER	DIMENSIONS IN INCHES						
		A BORE DIA.		B INNER O.D.		W WIDTH +.000 -.005	H HOLE DIA.	R MAX. FILLET FOR SHAFT
		NOM.	TOL. +.0000	NOM.	TOL. +.0000			
MI-6		.3750	-.0004	.6245	-.0004	1.010	3/32	.025
MI-6-N	MS 51962-1	.3750	-.0004	.6245	-.0004	.760	3/32	.025
MI-7-N		.4375	-.0004	.6245	-.0004	.760	3/32	.025
MI-8	MS 51962-3	.5000	-.0004	.7493	-.0005	1.010	1/8	.040
MI-8-N	MS 51962-2	.5000	-.0004	.7493	-.0005	.760	1/8	.040
MI-9-N		.5625	-.0004	.7493	-.0005	.760	1/8	.040
MI-10		.6250	-.0004	.8743	-.0005	1.010	1/8	.040
MI-10-N	MS 51962-4	.6250	-.0004	.8743	-.0005	.760	1/8	.040
MI-11-N		.6875	-.0004	.8743	-.0005	.760	1/8	.040
MI-12		.7500	-.0004	.9993	-.0005	1.010	1/8	.040
MI-12-N	MS 51962-5	.7500	-.0004	.9993	-.0005	.760	1/8	.040
MI-13	MS 51962-7	.8125	-.0005	.9993	-.0005	1.010	1/8	.040
MI-13-N	MS 51962-6	.8125	-.0005	.9993	-.0005	.760	1/8	.040
MI-14		.8750	-.0005	1.1241	-.0005	1.260	1/8	.040
MI-14-N	MS 51962-8	.8750	-.0005	1.1241	-.0005	1.010	1/8	.040
MI-15		.9375	-.0005	1.1241	-.0005	1.260	1/8	.040
MI-15-N	MS 51962-9	.9375	-.0005	1.1241	-.0005	1.010	1/8	.040
MI-16	MS 51962-11	1.0000	-.0005	1.2491	-.0006	1.260	1/8	.040
MI-16-N	MS 51962-10	1.0000	-.0005	1.2491	-.0006	1.010	1/8	.040
MI-17		1.0625	-.0005	1.3741	-.0006	1.260	1/8	.040
MI-18	MS 51962-13	1.1250	-.0005	1.3741	-.0006	1.260	1/8	.040
MI-18-N	MS 51962-12	1.1250	-.0005	1.3741	-.0006	1.010	1/8	.040
MI-19	MS 51962-14	1.1875	-.0005	1.4990	-.0006	1.260	1/8	.060
MI-20	MS 51962-16	1.2500	-.0005	1.4990	-.0006	1.260	1/8	.060
MI-20-N	MS 51962-15	1.2500	-.0005	1.4990	-.0006	1.010	1/8	.060
MI-21		1.3125	-.0005	1.6240	-.0006	1.260	1/8	.060
MI-21-N	MS 51962-17	1.3125	-.0005	1.6240	-.0006	1.010	1/8	.060

McGILL INNER RING NUMBER	MILITARY STANDARD NUMBER	DIMENSIONS IN INCHES						
		A BORE DIA.		B INNER O.D.		W WIDTH +.000 -.005	H HOLE DIA.	R MAX. FILLET FOR SHAFT
		NOM.	TOL. +.0000	NOM.	TOL. +.0000			
MI-22	MS 51962-19	1.3750	-.0005	1.7490	-.0006	1.260	1/8	.060
MI-22-4S	MS 51962-18	1.3750	-.0005	1.6240	-.0006	1.260	1/8	.060
MI-23	MS 51962-20	1.4375	-.0005	1.7490	-.0006	1.260	1/8	.060
MI-24	MS 51962-22	1.5000	-.0005	1.7490	-.0006	1.260	1/8	.060
MI-24-N	MS 51962-21	1.5000	-.0005	1.7490	-.0006	1.010	1/8	.060
MI-25		1.5625	-.0005	1.9989	-.0007	1.260	1/8	.060
MI-25-4S		1.5625	-.0005	1.8740	-.0006	1.260	1/8	.060
MI-26	MS 51962-23	1.6250	-.0005	1.9989	-.0007	1.260	1/8	.060
MI-26-2S		1.6250	-.0005	1.9364	-.0007	1.260	1/8	.060
MI-26-N		1.6250	-.0005	1.9989	-.0007	1.010	1/8	.060
MI-27		1.6875	-.0005	1.9989	-.0007	1.260	1/8	.060
MI-28	MS 51962-25	1.7500	-.0005	2.2489	-.0007	1.760	3/16	.060
MI-28-N	MS 51962-24	1.7500	-.0005	2.2489	-.0007	1.510	3/16	.060
MI-30		1.8750	-.0005	2.2489	-.0007	1.760	3/16	.060
MI-31	MS 51962-26	1.9375	-.0005	2.4989	-.0007	1.760	3/16	.080
MI-32		2.0000	-.0005	2.4989	-.0007	1.760	3/16	.080
MI-32-N	MS 51962-27	2.0000	-.0005	2.4989	-.0007	1.510	3/16	.080
MI-34		2.1250	-.0006	2.4989	-.0007	1.760	3/16	.080
MI-35	MS 51962-28	2.1875	-.0006	2.7489	-.0007	1.760	3/16	.080
MI-36		2.2500	-.0006	2.7489	-.0007	1.760	3/16	.080
MI-36-N	MS 51962-29	2.2500	-.0006	2.7489	-.0007	1.510	3/16	.080
MI-38	MS 51962-30	2.3750	-.0006	2.9989	-.0007	1.760	3/16	.080
MI-39		2.4375	-.0006	2.9989	-.0007	1.760	3/16	.080
MI-40		2.5000	-.0006	2.9989	-.0007	1.760	3/16	.080
MI-40-N	MS 51962-31	2.5000	-.0006	2.9989	-.0007	1.510	3/16	.080
MI-42		2.6250	-.0006	3.2487	-.0009	1.760	3/16	.080
MI-44	MS 51962-32	2.7500	-.0006	3.2487	-.0009	1.760	3/16	.080
MI-46		2.8750	-.0006	3.4987	-.0009	2.010	1/4	.080
MI-47	MS 51962-34	2.9375	-.0006	3.4987	-.0009	2.010	1/4	.080
MI-48		3.0000	-.0006	3.4987	-.0009	2.010	1/4	.080
MI-48-N		3.0000	-.0006	3.4987	-.0009	1.760	1/4	.080
MI-50	MS 51962-35	3.1250	-.0006	3.7487	-.0009	2.010	1/4	.100
MI-52	MS 51962-36	3.2500	-.0006	3.7487	-.0009	2.010	1/4	.100
MI-54	MS 51962-38	3.3750	-.0008	3.9985	-.0009	2.010	1/4	.100
MI-56		3.5000	-.0008	3.9985	-.0009	2.010	1/4	.100
MI-58		3.6250	-.0008	4.2485	-.0009	2.010	1/4	.100
MI-60	MS 51962-40	3.7500	-.0008	4.2485	-.0009	2.010	1/4	.100
MI-62		3.8750	-.0008	4.4985	-.0009	2.260	1/4	.100
MI-64		4.0000	-.0008	4.9985	-.0010	2.260	1/4	.100
MI-68		4.2500	-.0008	4.9985	-.0010	2.260	1/4	.100
MI-72	MS 51962-44	4.5000	-.0008	5.4985	-.0010	3.015	1/4	.100
MI-72-N	MS 51962-43	4.5000	-.0008	5.4985	-.0010	2.515	1/4	.100
MI-80	MS 51962-47	5.0000	-.0010	5.9983	-.0010	3.015	5/16	.120
MI-80-N	MS 51962-46	5.0000	-.0010	5.9983	-.0010	2.515	5/16	.120
MI-88	MS 51962-49	5.5000	-.0010	6.4983	-.0010	3.015	5/16	.120
MI-88-N	MS 51962-48	5.5000	-.0010	6.4983	-.0010	2.515	5/16	.120
MI-96	MS 51962-50	6.0000	-.0010	7.2481	-.0012	3.015	5/16	.120
MI-104		6.5000	-.0010	7.7481	-.0012	3.015	5/16	.120
MI-112		7.0000	-.0010	8.2481	-.0012	3.015	5/16	.120
MI-120		7.5000	-.0012	8.7480	-.0012	3.015	5/16	.160
MI-128		8.0000	-.0012	9.2480	-.0012	3.015	5/16	.160

CAGEROL®/GUIDEROL®
Bearings

INTERCHANGEABILITY CHART

Inner race only

* TORRINGTON®	R.B.C.	* INA®	McGILL	* TORRINGTON®	R.B.C.	* INA®	McGILL
IR-061012		PI-061012	MI-6-N MI-6	IR-314028	IR-8407-C1 IR-8447		MI-30 MI-31
IR-081212	IR-7153	PI-081212	MI-7-N MI-8-N	IR-324024 IR-324028	IR-8446-C IR-8447-C IR-8447-C1	PI-324024	MI-32-N MI-32 MI-34
IR-081216	IR-7154 IR-7153-C	PI-081216	MI-8 MI-9-N	IR-354428 IR-364424	IR-8477 IR-8476-C	PI-364424	MI-35 MI-36-N
IR-101412	IR-7173	PI-101412	MI-10-N	IR-364428	IR-8477-C		MI-36
IR-101416	IR-7174	PI-101416	MI-10	IR-384828	IR-8517		MI-38
IR-111412	IR-7173-C		MI-11-N				MI-39
IR-121612	IR-7193	PI-121612	MI-12-N	IR-404824	IR-8516-C	PI-404824	MI-40-N
IR-121616	IR-7194	PI-121616	MI-12 MI-13-N	IR-404828	IR-8517-C IR-9567-D		MI-40 MI-42
IR-131616	IR-7194-C		MI-13	IR-445228	IR-9567	PI-445228	MI-44
IR-141816	IR-7214	PI-141816	MI-14-N				MI-46
IR-141820	IR-7215	PI-141820	MI-14				
IR-151816			MI-15-N	IR-475632	IR-9608		MI-47
IR-151820	IR-7215-C		MI-15				MI-48-N
IR-162016	IR-7234	PI-162016	MI-16-N	IR-485632	IR-9608-C	PI-485632	MI-48
IR-162020	IR-7235 IR-7255-D	PI-162020	MI-16 MI-17	IR-506032 IR-526032	IR-9648 IR-9648-C		MI-50 MI-52
IR-182216	IR-7254	PI-182216	MI-18-N	IR-546432	IR-9688		MI-54
IR-182220	IR-7255	PI-182220	MI-18	IR-566432	IR-9688-C		MI-56
IR-192420	IR-7275		MI-19		IR-9728-C		MI-58
IR-202416		PI-202416	MI-20-N	IR-606832	IR-9728-C1		MI-60
IR-202420	IR-7275-C	PI-202420	MI-20		IR-6769-C		MI-62
IR-212616	IR-7294	PI-212616	MI-21-N	IR-648036	IR-6849		MI-64
IR-212620	IR-7295		MI-21	IR-688036	IR-6849-C		MI-68
IR-222620	IR-7295-C	PI-222620	MI-22-4S	IR-728840	IR-6918		MI-72-N
IR-222820			MI-22	IR-728848	IR-6919		MI-72
IR-232820	IR-7315	PI-232820	MI-23	IR-809640	IR-6925		MI-80-N
IR-242816		PI-242816	MI-24-N				
IR-242820	IR-7315-C	PI-242820	MI-24	IR-809648	IR-6926		MI-80
IR-253020	IR-7335	PI-253020	MI-25-4S	IR-8810440	IR-6935		MI-88-N
IR-253220	IR-7345		MI-25 MI-26-2S MI-26-N	IR-8810448 IR-9611648	IR-6936 IR-2326		MI-88 MI-96
IR-263220	IR-7355-D		MI-26	IR-10412448	IR-2426		MI-104
IR-273220	IR-7355	PI-273220	MI-27	IR-11213248	IR-2526		MI-112
IR-283624	IR-8406	PI-283624	MI-28-N	IR-12014048	IR-2626		MI-120
IR-283628	IR-8407	PI-283624	MI-28	IR-12814848	IR-2726		MI-128

* The trademark TORRINGTON is a registered trademark of The Torrington Company.
The trademark INA is a registered trademark of Industriewerk Schaeffler, O. H. G.

Sealed

Outer ring, roller and inner ring assemblies only

* TORRINGTON®		R.B.C.		McGILL NUMBER	
OUTER	INNER	OUTER	INNER	OUTER RING AND ROLLER ASSEMBLY GUIDEROL® OR CAGEROL® BEARINGS	INNER RING ONLY
HJRR-101816		SJ-7134-RR		10-SS	MI-6
HJRR-122016	IR-081216	SJ-7154-RR	IR-7154	12-SS	MI-8
HJRR-142216	IR-101416	SJ-7174-RR	IR-7174	14-SS	MI-10
HJRR-162416	IR-121616	SJ-7194-RR	IR-7194	16-SS	MI-12
HJRR-162416	IR-131616	SJ-7194-RR	IR-7194-C	16-SS	MI-13
HJRR-182620	IR-141820	SJ-7215-RR	IR-7215	18-SS	MI-14
HJRR-182620	IR-151820	SJ-7215-RR	IR-7215-C	18-SS	MI-15
HJRR-202820	IR-162020	SJ-7235-RR	IR-7235	20-SS	MI-16
		SJ-7255-RR	IR-7255-D	22-SS	MI-17
HJRR-223020	IR-182220	SJ-7255-RR	IR-7255	22-SS	MI-18
HJRR-243320	IR-192420	SJ-7275-RR	IR-7275	24-SS	MI-19
HJRR-243320	IR-202420	SJ-7275-RR	IR-7275-C	24-SS	MI-20
HJRR-263520	IR-212620	SJ-7295-RR	IR-7295	26-SS	MI-21
HJRR-263520	IR-222620	SJ-7295-RR	IR-7295-C	26-SS	MI-22-4S
HJRR-283720	IR-222820			28-SS	MI-22
HJRR-283720	IR-232820	SJ-7315-RR	IR-7315	28-SS	MI-23
	IR-242820	SJ-7315-RR	IR-7315-C	28-SS	MI-24
		SJ-7335-RR	IR-7335	30-SS	MI-25-4S
				32-SS	MI-25
HJRR-324120	IR-253220	SJ-7355-RR	IR-7355-D	32-SS	MI-26
HJRR-324120	IR-263220			32-SS	MI-26
HJRR-324120	IR-273220	SJ-7355-RR	IR-7355	32-SS	MI-27
HJRR-364828	IR-283628	SJ-8407-RR	IR-8407	36-SS	MI-28
		SJ-8407-RR	IR-8407--CI1	36-SS	MI-30
HJRR-405228	IR-314028	SJ-8447-RR	IR-8447	40-SS	MI-31
HJRR-405228	IR-324028	SJ-8447-RR	IR-8447-C	40-SS	MI-32
		SJ-8447-RR	IR-8447--CI1	40-SS	MI-34
HJRR-445628	IR-354428	SJ-8477-RR	IR-8477	44-SS	MI-35
HJRR-445628	IR-364428	SJ-8477-RR	IR-8477-C	44-SS	MI-36
HJRR-486028	IR-384828	SJ-8517-RR	IR-8517	48-SS	MI-38
				48-SS	MI-39
HJRR-486028	IR-404828	SJ-8517-RR	IR-8517-C	48-SS	MI-40
				52-SS	MI-42
				52-SS	MI-44
				56-SS	MI-46
		SJ-9608-RR	IR-9608	56-SS	MI-47
		SJ-9608-RR	IR-9608-C	56-SS	MI-48
		SJ-9648-RR	RR-9648	60-SS	MI-50
		SJ-9648-RR	IR-9648-C	60-SS	MI-52
		SJ-9688-RR	IR-9688	64-SS	MI-54
		SJ-9688-RR	IR-9688-C	64-SS	MI-56
				68-SS	MI-58
				68-SS	MI-60

** GR prefix indicates center guide full complement construction.
MR prefix indicates retainer type construction.

Outer ring and roller assemblies only

* TORRINGTON®	R.B.C.	McGILL NUMBER **GR OR MR BEARINGS
HJRR-101816	SJ-7134-RR	10-SS
HJRR-122016	SJ-7154-RR	12-SS
HJRR-142216	SJ-7174-RR	14-SS
HJRR-162416	SJ-7194-RR	16-SS
HJRR-182620	SJ-7215-RR	18-SS
HJRR-202820	SJ-7235-RR	20-SS
HJRR-223020	SJ-7255-RR	22-SS
HJRR-243320	SJ-7275-RR	24-SS
HJRR-263520	SJ-7295-RR	26-SS
HJRR-283720	SJ-7315-RR	28-SS
	SJ-7335-RR	30-SS
HJRR-324120	SJ-7355-RR	32-SS
HJRR-364828	SJ-8407-RR	36-SS
HJRR-405228	SJ-8447-RR	40-SS
HJRR-445628	SJ-8477-RR	44-SS
HJRR-486028	SJ-8517-RR	48-SS
	SJ-9568-RR	52-SS
	SJ-9608-RR	56-SS
	SJ-9648-RR	60-SS
	SJ-9688-RR	68-SS
		64-SS

** GR prefix indicates center guide full complement construction.
MR prefix indicates retainer type construction.

CAGEROL®/GUIDEROL® Bearings

Types of seal configurations

DESCRIPTION	* TORRINGTON®	R.B.C.	McGILL NUMBER
Double seal with lips turned inward	HJRR-	-RR	-SS
Double seal with lips turned outward	HJTT-	-SS	-RSS
Double seal with one lip turned outward and one lip turned inward	HJTR-	-SR	-SRS
Single seal with lip turned inward	HJR-	-R	-S
Single seal with lip turned outward	HJT-	-S	-RS

* The trademark TORRINGTON is a registered trademark of The Torrington Company.

INTERCHANGEABILITY CHART

Outer ring, roller and inner ring assemblies

* TORRINGTON®	R.B.C.	* INA®	McGILL	
			GUIDEROL MT	CAGEROL MR
HJ-101812 IR-061012		NCS-1012 PI-061012	GR-10-N MI-6-N GR-10-N MI-7-N GR-10 MI-6	MR-10-N MI-6-N MR-10-N MI-7-N MR-10 MI-6
HJ-122012 IR-081212	SJ-7153 IR-7153 SJ-7153 IR-7153-C	NCS-1212 PI-081212	GR-12-N MI-8-N GR-12-N MI-9-N GR-12 MI-8	MR-12-N MI-8-N MR-12-N MI-9-N MR-12 MI-8
HJ-122016 IR-081216	SJ-7154 IR-7154	NCS-1216 PI-081216		
HJ-142212 IR-101412	SJ-7173 IR-7173	NCS-1412 PI-101412	GR-14-N MI-10-N GR-14-N MI-11-N	MR-14-N MI-10-N MR-14-N MI-11-N
HJ-111412 HJ-142216 IR-101416	IR-7173-C SJ-7174 IR-7174	NCS-1416 PI-101416	GR-14 MI-10	MR-14 MI-10
HJ-162412 IR-121612	SJ-7193 IR-7193	NCS-1612 PI-121612	GR-16-N MI-12-N	MR-16-N MI-12-N
HJ-162416 IR-121616	SJ-7194 IR-7194	NCS-1616 PI-121616	GR-16 MI-12	MR-16 MI-12
HJ-162416 IR-131616	SJ-7194 IR-7194-C		GR-16 MI-13	MR-16 MI-13
HJ-182616 IR-141816	SJ-7214 IR-7214	NCS-1816 PI-141816	GR-18-N MI-14-N	MR-18-N MI-14-N
HJ-182616 IR-151816			GR-18-N MI-15-N	MR-18-N MI-15-N
HJ-182620 IR-141820	SJ-7215 IR-7215	NCS-1820 PI-141820	GR-18 MI-14	MR-18 MI-14
HJ-182620 IR-151820	SJ-7215 IR-7215-C		GR-18 MI-15	MR-18 MI-15
HJ-202816 IR-162016	SJ-7234 IR-7234	NCS-2016 PI-162016	GR-20-N MI-16-N	MR-20-N MI-16-N
HJ-202820 IR-162020	SJ-7235 IR-7235	NCS-2020 PI-162020	GR-20 MI-16	MR-20 MI-16
HJ-223016 IR-182216	SJ-7254 IR-7254 SJ-7255 IR-7255-D	NCS-2216 PI-182216	GR-22-N MI-18-N GR-22 MI-17	MR-22-N MI-18-N MR-22 MI-17
HJ-223020 IR-182220	SJ-7255 IR-7255	NCS-2220 PI-182220	GR-22 MI-18	MR-22 MI-18
HJ-243316 IR-202416		NCS-2416 PI-202416	GR-24-N MI-20-N	MR-24-N MI-20-N
HJ-243320 IR-192420	SJ-7275 IR-7275		GR-24 MI-19	MR-24 MI-19
HJ-243320 IR-202420	SJ-7275 IR-7275-C	NCS-2420 PI-202420	GR-24 MI-20	MR-24 MI-20
HJ-263516 IR-212616	SJ-7294 IR-7294	NCS-2616 PI-212616	GR-26-N MI-21-N	MR-26-N MI-21-N
HJ-263520 IR-212620	SJ-7295 IR-7295		GR-26 MI-21	MR-26 MI-21
HJ-263520 IR-222620	SJ-7295 IR-7295-C	NCS-2620 PI-222620	GR-26 MI-22-4S	MR-26 MI-22-4S
HJ-283716 IR-242816		NCS-2816 PI-242816		MR-28-N MI-24-N
HJ-283720 IR-222820			GR-28 MI-22	MR-28 MI-22
HJ-283720 IR-232820	SJ-7315 IR-7315	NCS-2820 PI-232820	GR-28 MI-23	MR-28 MI-23
HJ-283720 IR-242820	SJ-7315 IR-7315-C	NCS-2820 PI-242820	GR-28 MI-24	MR-28 MI-24

* The trademark TORRINGTON is a registered trademark of The Torrington Company.
The trademark INA is a registered trademark of Industriewerk Schaeffler, O. H. G.

Outer ring, roller and inner ring assemblies

* TORRINGTON®	R.B.C.	* INA®	McGILL	
			GUIDEROL MT	CAGEROL MR
HJ-303920 IR-253020 HJ-324120 IR-253220	SJ-7335 IR-7335 SJ-7345 IR-7345	NCS-3020 PI-253020	GR-30 MI-25-4S GR-31 MI-26-2S GR-32-N MI-26-N GR-32 MI-25	MR-30 MI-25-4S MR-31 MI-26-2S MR-32-N MI-26-N MR-32 MI-25
HJ-324120 IR-263220 HJ-324120 IR-273220	SJ-7355 IR-7335-D SJ-7355 IR-7355	NCS-3220 PI-273220	GR-32 MI-26 GR-32 MI-27	MR-32 MI-26 MR-32 MI-27
HJ-364824 IR-283624 HJ-364828 IR-283628	SJ-8406 IR-8406 SJ-8407 IR-8407	NCS-3624 PI-283624	GR-36-N MI-28-N GR-36 MI-28	MR-36-N MI-28-N MR-36 MI-28
HJ-405224 IR-324024 HJ-405228 IR-314028	SJ-8407 IR-8407-C1 SJ-8446 IR-8446-C SJ-8447 IR-8479	NCS-4024 PI-324024	GR-36 MI-30 GR-40-N MI-32-N GR-40 MI-31	MR-36 MI-30 MR-40-N MI-32-N MR-40 MI-31
HJ-405228 IR-324028 HJ-445624 IR-364424	SJ-8447 IR-8447-C SJ-8447 IR-8447-C1 SJ-8476 IR-8476-C	NCS-4424 PI-364424	GR-40 MI-32 GR-40 MI-34 GR-44-N MI-36-N	MR-40 MI-32 MI-34 MR-44-N MI-36-N
HJ-445628 IR-354428 HJ-445628 IR-364428 HJ-486024 IR-404824	SJ-8477 IR-8477 SJ-8477 IR-8477-C SJ-8516 IR-8516-C	NCS-4824 PI-404824	GR-44 MI-35 GR-44 MI-36 GR-48-N MI-40-N	MR-44 MI-35 MR-44 MI-36 MR-48-N MI-40-N
HJ-486028 IR-384828 HJ-486028 IR-404828	SJ-8517 IR-8517 SJ-8517 IR-8517-C		GR-48 MI-38 GR-48 MI-39 GR-48 MI-40	MR-48 MI-38 MR-48 MI-39 MR-48 MI-40
HJ-526828 IR-445228	SJ-9567 IR-9567-D SJ-9567 IR-9567	NCS-5228 PI-445228	GR-52 MI-42 GR-52 MI-44 GR-56-N MI-48-N	MR-52 MI-42 MR-52 MI-44 MR-56-N MI-48-N
HJ-567232 IR-475632 HJ-567232 IR-485632	SJ-9608 IR-9608 SJ-9608 IR-9608-C	NCS-5632 PI-485632	GR-56 MI-46 GR-56 MI-47 GR-56 MI-48	MR-56 MI-46 MR-56 MI-47 MR-56 MI-48
HJ-607632 IR-506032 HJ-607632 IR-526032 HJ-648032 IR-546432	SJ-9648 IR-9648 SJ-9648 IR-9648-C SJ-9688 IR-9688		GR-60 MI-50 GR-60 MI-52 GR-64 MI-54	MR-60 MI-50 MR-60 MI-52 MR-64 MI-54
HJ-648032 IR-566432 HJ-688432 IR-606832	SJ-9688 IR-9688-C SJ-9728 IR-9728-C1 SJ-9728 IR-9728-C		GR-64 MI-56 GR-68 MI-60 GR-68 MI-58	MR-64 MI-56 MR-68 MI-60 MR-68 MI-58

* The trademark TORRINGTON is a registered trademark of The Torrington Company.
The trademark INA is a registered trademark of Industrierwerk Schaeffler, O. H. G.

INTERCHANGEABILITY CHART (Cont'd.)
Outer ring, roller and inner ring assemblies

* TORRINGTON®	R.B.C.	* INA®	McGILL	
			GUIDEROL MT	CAGEROL MR
HJ-8010436 IR-648036 HJ-8010436 IR-688036	SJ-6769 IR-6769-C SJ-6849 IR-6849 SJ-6849 IR-6849-C		GR-72 MI-62 GR-80 MI-64 GR-80 MI-68	MR-72 MI-62 MR-80 MI-64 MR-80 MI-68
HJ-8811240 IR-728840 HJ-8811248 IR-728848 HJ-9612040 IR-809640	SJ-6918 IR-6918 SJ-6919 IR-6919 SJ-6925 IR-6925		GR-88-N MI-72-N GR-88 MI-72 GR-96-N MI-80-N	MR-88-N MI-72-N MR-88 MI-72 MR-96-N MI-80-N
HJ-9612048 IR-809648 HJ-10412840 IR-8810440 HJ-10412848 IR-8810448	SJ-6926 IR-6926 SJ-6935 IR-6935 SJ-6936 IR-6936		GR-96 MI-80 GR-104-N MI-88-N GR-104 MI-88	MR-96 MI-80 MR-104-N MI-88-N MR-104 MI-88
HJ-11614648 IR-9611648 HJ-12415448 IR-10412448 HJ-13216248 IR-11213248	SJ-2326 IR-2326 SJ-2426 IR-2426 SJ-2526 IR-2526		GR-116 MI-96 GR-124 MI-104 GR-132 MI-112	MR-116 MI-96 MR-124 MI-104 MR-132 MI-112
HJ-14017048 IR-12014048 HJ-14817848 IR-12814848	SJ-2626 IR-2626 SJ-2726 IR-2726		GR-140 MI-120 GR-148 MI-128	MR-140 MI-120 MR-148 MI-128

* The trademark TORRINGTON is a registered trademark of The Torrington Company.
The trademark INA is a registered trademark of Industriewerk Schaeffler, O. H. G.

Outer ring and roller assemblies only

*TORRINGTON®	R.B.C.	* INA®	McGILL	
			GUIDEROL MT	CAGEROL MR
HJ-101812	SJ-7133 SJ-7134	NCS-1012 NCS-1016	GR-10-N GR-10	MR-10-N MR-10
HJ-122012	SJ-7153	NCS-1212	GR-12-N	MR-12-N
HJ-122016	SJ-7154	NCS-1216	GR-12	MR-12
HJ-142212	SJ-7173	NCS-1412	GR-14-N	MR-14-N
HJ-142216	SJ-7174	NCS-1416	GR-14	MR-14
HJ-162412	SJ-7193	NCS-1612	GR-16-N	MR-16-N
HJ-162416	SJ-7194	NCS-1616	GR-16	MR-16
HJ-182616	SJ-7214	NCS-1816	GR-18-N	MR-18-N
HJ-182620	SJ-7215	NCS-1820	GR-18	MR-18
HJ-202816	SJ-7234	NCS-2016	GR-20-N	MR-20-N
HJ-202820	SJ-7235	NCS-2020	GR-20	MR-20
HJ-223016	SJ-7254	NCS-2216	GR-22-N	MR-22-N
HJ-223020	SJ-7255	NCS-2220	GR-22	MR-22
HJ-243316	SJ-7274	NCS-2416	GR-24-N	MR-24-N
HJ-243320	SJ-7275	NCS-2420	GR-24	MR-24
HJ-263516	SJ-7294	NCS-2616	GR-26-N	MR-26-N
HJ-263520	SJ-7295	NCS-2620	GR-26	MR-26
HJ-283716	SJ-7314	NCS-2816		MR-28-N
HJ-283720	SJ-7315 SJ-7334	NCS-2820 NCS-3016	GR-28	MR-28 MR-30-N
HJ-303920	SJ-7335 SJ-7345	NCS-3020	GR-30	MR-30 MR-31
HJ-324116	SJ-7354	NCS-3216	GR-32-N	MR-32-N
HJ-324120	SJ-7355	NCS-3220	GR-32	MR-32
HJ-364824	SJ-8406	NCS-3624	GR-36-N	MR-36-N
HJ-364828	SJ-8407		GR-36	MR-36
HJ-405224	SJ-8446	NCS-4024	GR-40-N	MR-40-N
HJ-405228	SJ-8447		GR-40	MR-40
HJ-445624	SJ-8476	NCS-4424	GR-44-N	MR-44-N
HJ-445628	SJ-8477		GR-44	MR-44
HJ-486024	SJ-8516	NCS-4824	GR-48-N	MR-48-N
HJ-486028	SJ-8517		GR-48	MR-48
HJ-526828	SJ-9567 SJ-9607	NCS-5228	GR-52 GR-56-N	MR-52 MR-56-N
HJ-567232	SJ-9608	NCS-5632	GR-56	MR-56
HJ-607632	SJ-9648		GR-60	MR-60
HJ-648032	SJ-9688		GR-64	MR-64
HJ-688432	SJ-9728	NCS-6832	GR-68	MR-68
HJ-729636	SJ-6769		GR-72	MR-72
HJ-8010436	SJ-6849		GR-80	MR-80
HJ-8811240	SJ-6918		GR-88-N	MR-88-N
HJ-8811248	SJ-6919		GR-88	MR-88
HJ-9612040	SJ-6925		GR-96-N	MR-96-N
HJ-9612048	SJ-6926		GR-96	MR-96
HJ-10412840	SJ-6935		GR-104-N	MR-104-N
HJ-10412848	SJ-6936		GR-104	MR-104
HJ-11614648	SJ-2326		GR-116	MR-116
HJ-12415448	SJ-2426		GR-124	MR-124
HJ-13216248	SJ-2526		GR-132	MR-132
HJ-14017048	SJ-2626		GR-140	MR-140
HJ-14817848	SJ-2726		GR-148	MR-148

CAGEROL®/GUIDEROL® Bearings

* The trademark TORRINGTON is a registered trademark of The Torrington Company.
 The trademark INA is a registered trademark of Industrierwerk Schaeffler, O. H. G.

MR & SMR SERIES

BEARING APPLICATIONS

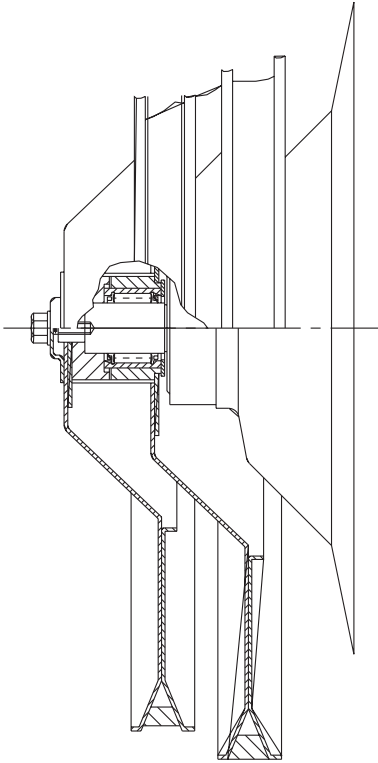
**Domestic Washer Tub Shaft**

Special CAGEROL® MR Series bearings applied to heavily loaded tub shaft support position on automatic clothes washer. Prepacked with lubricant and operating in restricted areas, this cage type bearing results in longer life.

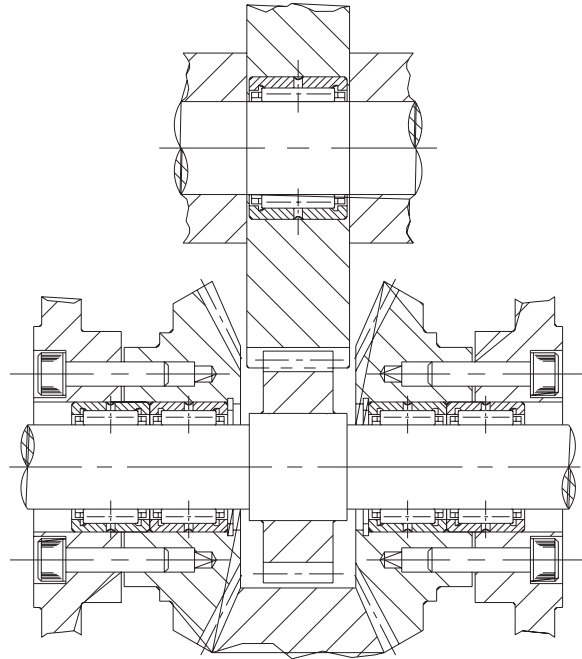
**Industrial Equipment Transmission**

CAGEROL® MR Series bearings applied to bevel pinion shaft and idler gear shaft. Used also for other transmission applications such as planetary gears, pilot shafts and forward and reverse clutch shafts.

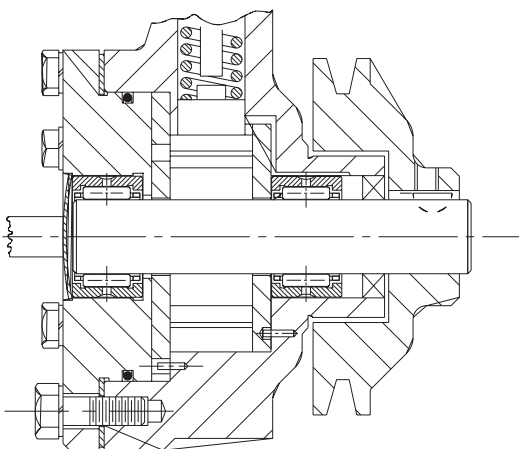
**Vane Pumps**

MR Series CAGEROL® bearings shown as rotor shaft bearings in vane pumps. Positive roller guidance with caged construction resists misalignment and eliminates rotor thrusting against wear plates.

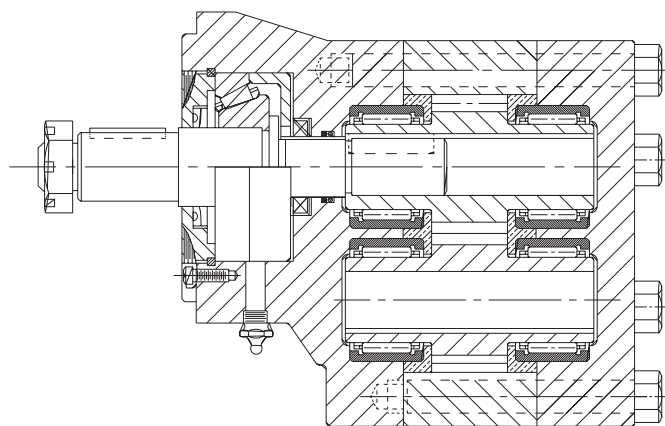
**Hydraulic Gear Pump**

CAGEROL® MR Series bearings support the drive and driven shafts in hydraulic gear pumps. Crowned rollers with sturdy retainer construction increases fatigue life in such applications.

BEARING APPLICATIONS

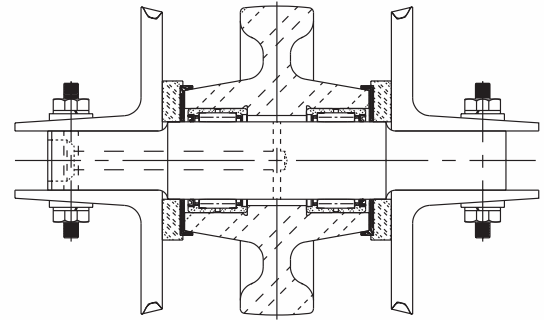
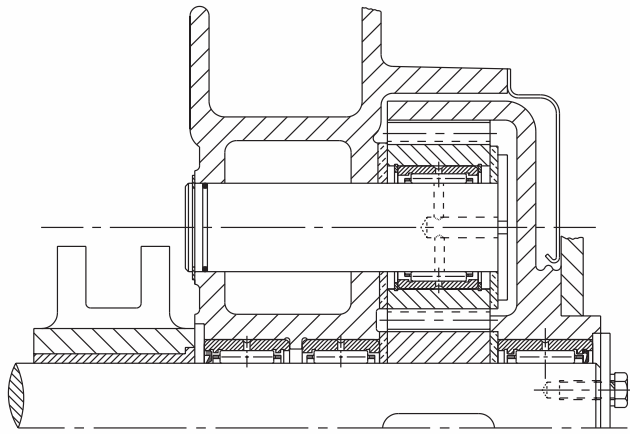

Power Shovel Boom Hoist Shaft

Sealed SMR and unsealed MR Series CAGEROL® bearings shown applied on boom shaft and planetary gear power shovel and crane applications.

Power Shovel Track Roller

Sealed SMR Series CAGEROL® bearings support this heavily loaded crawler track roller on cranes and power shovels.

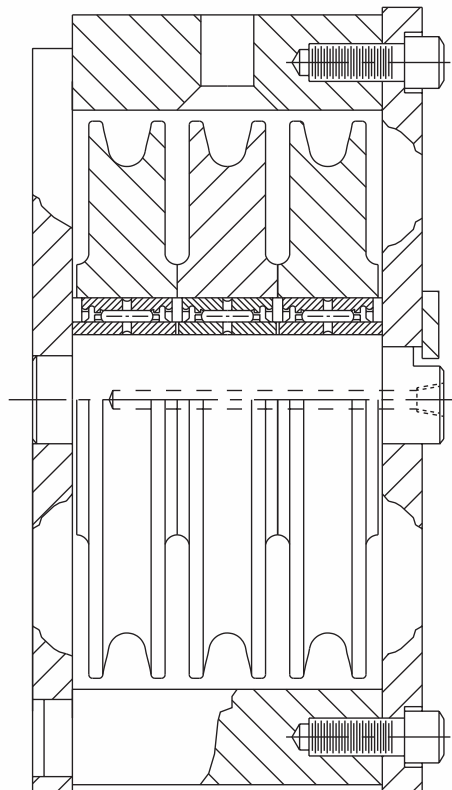

Cable Control Sheaves

CAGEROL® SMR Series bearings shown in three part sheave for cable controls. These caged bearings offer resistance to misalignment and integral seals with integral grease reservoir reduce maintenance.

ENGINEERING SECTION

Unique design and construction features provide greater capacity, longer life and accommodation of misalignment.

McGill SB series SPHERE-ROL® bearings present all of the inherent advantages of a single row spherical roller bearing, plus the option of integral seals. Higher capacities, higher limiting speeds, longer life under more misalignment and protection from contaminants permit greater design latitude than is sometimes possible with comparable 2-row spherical roller bearings.

Load ratings can exceed comparable bearings by as much as 17% and combination radial and thrust loads are easily accommodated. Limiting speeds can be up to 15% greater

than those of comparable bearings. Misalignment up to $\pm 3^\circ$ is accommodated by the unsealed versions and up to $\pm 2^\circ$ by the sealed versions. SPHERE-ROL® bearings from McGill are dimensionally interchangeable with ordinary 2-row spherical roller bearings. However, they offer the design engineer a more efficient bearing design that helps provide improved performance.



Equivalent loads

When SPHERE-ROL® bearings operate under conditions of combined radial and thrust loads, an equivalent radial load must be calculated to determine resultant bearing life. SPHERE-ROL® bearings are not recommended for applications involving pure thrust loads; however, combination loads may be carried in accordance with the following equivalent radial load formulae:

When $\frac{F_a}{F_r} \leq 0.12$; $P = VF_r$
 When $\frac{F_r}{F_a} > 0.12$; $P = .4VF_r + 5.0 F_a$

- P = Equiv. radial load, lbs.
- F_r = Applied radial load, lbs.
- F_a = Applied thrust load, lbs.
- V^a = Rotation factor
 = 1.0 for most applications
 = 1.2 for vibratory applications

For applications involving combination loads in which $F_a/F_r > .20$, consult McGill Engineering Department.

Life calculations

The "rating life" for any given application and bearing selection can be calculated by using the bearing basic dynamic load rating, applied radial load (or equivalent radial load, in the case of applications involving combined radial and thrust loads) and the speed of bearing rotation. Conversely, required bearing basic dynamic load ratings can be obtained for any specific application for which the life requirements, loads and speeds are specified.

To determine the resultant life when bearing size, load and speed are known, or the bearing load rating required for a given life, load and speed, use the equations shown on page 2 of the general engineering section of the catalog.

Static load rating

The "static load rating" is that uniformly distributed static radial bearing load which produces a maximum contact stress of 580,000 PSI, acting at the center of contact of the most heavily loaded rolling element. At this stress level, plastic deformation begins (or begins to be significant). Experience has shown that the plastic deformation at this stress level can be tolerated in most bearing applications without impairment of subsequent bearing operation. In certain applications where subsequent rotation of the bearing is slow and where smoothness and friction requirements are not too exacting, a higher static load limit can be tolerated. Where extreme smoothness is required or friction requirements are critical, a lower static load limit may be necessary.

When static bearings are subjected to both radial and thrust loads, the equivalent static radial load is defined as:

$P_o = 0.5 F_r + 4.0 F_a$ or
 $P_o = F_r$ whichever is greater.

Contact the McGill Engineering Department for specific static load ratings, and applications involving pure static thrust loads.

Tapered bore bearing

SPHERE-ROL® bearings are available from McGill with tapered bore feature for applications utilizing tapered adapter sleeve mounting arrangements or tapered shaft seats. This feature sometimes facilitates the mounting of SPHERE-ROL® bearings and can be used to prevent the necessity for heating of bearings or to eliminate the need for complicated press fitting practices. Standard tapered adapter sleeves, as well as associated lock nuts and lock washers, are tabulated on pages 95 and 97 and are identifiable with the appropriate bearing by the suffix number. The separate items may be called out individually by their part number or the complete tapered bore bearing and associated hardware may be identified by the suffix letter "A" following the bearing number. The standard bore taper of these bearings is 1" in 12", on the diameter, and tapered bore bearings are themselves identified by the suffix letter "K" following the basic bearing number.

In mounting, the bearing bore is forced against the taper of the split adapter sleeve or the tapered shaft seat by the action of a lock nut. A progressively tighter fit can be obtained by tightening the lock nut to increase the axial displacement of the bearing along the taper. Due to the need for greater take-up of internal clearance with this type of mounting, special internal clearances are provided. Care must be exercised to insure that the optimum take-up of internal clearance is followed. Too great a reduction of internal clearance will result in potential overheating of the bearing in many applications.

The mounting procedure for adapter mounted, tapered bore bearings recommended by McGill does not require the use of feeler gauge or special gauging procedure.

ENGINEERING SECTION

The basic principle of this measurement system is the use of the lock nut and lock washer as a protractor device. Because the lock nuts available for each basic bearing size are standard items, they are manufactured to specific thread pitches. Thus, the axial advancement for each revolution of the nut is predetermined, and the portions of revolutions of the lock nuts required to obtain the correct internal clearance reduction is also predetermined. Additionally, the standard lock washers have a specific number of tangs for each size, and these tangs can be used as the protractor for determining the correct portions of revolutions of the lock nuts. The basic procedure is as follows:

1. To reduce friction and facilitate mounting, apply a medium weight oil to the bearing bore, the outside diameter of the adapter sleeve, all threads and the face of the lock nut.

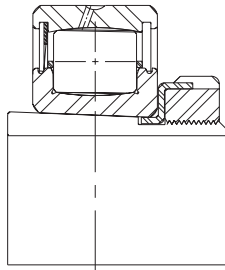

2. Mount the bearing on the tapered seat with a snug fit between the adapter bore and the shaft seat, with the lock nut and lock washer mounted snugly against the face of the bearing inner ring. (A snug fit is obtained when the adapter sleeve no longer rotates when the lock nut is tightened.) At this point, no internal clearance has been removed from the bearing and any advancement of the lock nut will result in reduction of internal clearance due to interference between the bearing bore and tapered seat.

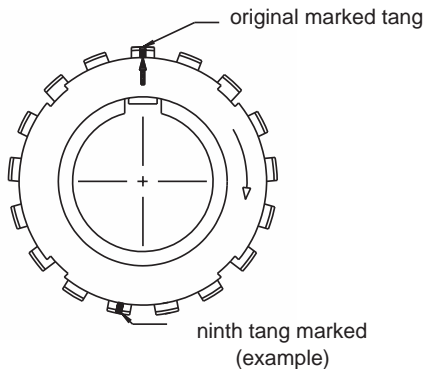

3. Mark a lock washer tang in any suitable manner, and the adjacent, mating area of the lock nut.
4. Count in the direction of tightening, a certain number of tangs, specified at the right.
5. Mark the specified lock washer tang.

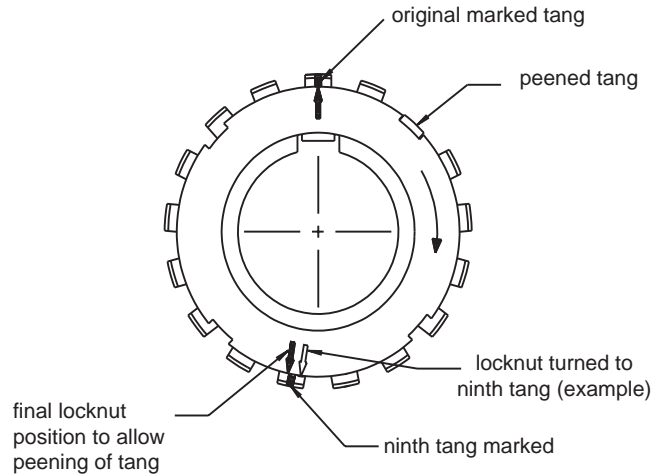

6. Tighten the lock nut until the marked area on the lock nut is in line with the prescribed lock washer tang. (Lightly striking the face of the lock nut with a soft steel bar will reduce thread pressure and make tightening easier.)
7. If, at this point, none of the tangs line up directly with a corresponding slot in the lock nut OD, rotate the lock nut, in a tightening direction, the additional small amount required to line up the closest slot and tang.

Clearance reduction — (-K suffix)

BEARING BORE IN MILLIMETERS	DIAMETRAL CLEARANCE REDUCTION INCHES	LOCK NUT TURNS DEGREES	ABMA LOCK WASHER NUMBER	REQ'D. NO. OF LOCK WASHER TANGS FOR CLEARANCE REDUCTION
25	.0009	277	W-05	10
30	.0009	204	W-06	7
35	.0009	204	W-07	9
40	.0009	204	W-08	9
45	.0010	215	W-09	10
50	.0010	215	W-10	10
55	.0010	215	W-11	10
60	.0010	215	W-12	10
65	.0010	215	W-13	11
70	.0015	273	W-14	14
75	.0015	146	W-15	8
80	.0015	146	W-16	8
85	.0015	146	W-17	8
90	.0015	146	W-18	8
95	.0015	146	W-19	8
100	.0015	146	W-20	8
110	.0020	177	W-22	9
120	.0020	177	W-24	9
130	.0025	207	W-26	11
140	.0025	207	W-28	11
150	.0030	238	W-30	13

8. The correct internal clearance has now been obtained and the lock washer tang can be peened into the slot of the lock nut, thereby locking the assembly.

The more common procedure used for determining the proper fit of spherical roller bearings on tapered seat is to measure the reduction of internal clearance of the bearing, upon mounting, through the use of feeler gauges or shim stock. This procedure can be utilized with the non-sealed SPHERE-ROL® bearing, if desired. The customer must initially measure and verify the clearance existing in the unmounted bearing, then press the bearing on the tapered seat until the specified amount of clearance has been removed, checking with the feeler gauges. The chart at left gives the required diametral clearance reductions which should be used when the feeler gauging procedure is utilized.

NYLAPLATE® seals



The NYLAPLATE® seals have very low running friction and seals can be compounded from a variety of materials, where required, to resist different types of contaminants and to meet different application temperature conditions. Nylaplate sealed SPHERE-ROL® bearings are identified by adding the suffix "S" to the bearing number for single sealed bearings and "SS" for double NYLAPLATE® seals. For tapered bore bearings, using the single seal, add suffix "S" to indicate the seal on the small bore side, and "SL" to indicate the seal in the large bore side.

Sealed SPHERE-ROL® bearings containing standard NYLAPLATE® seals from McGill should not be operated at temperatures exceeding 300°F. When higher operating temperatures are encountered, special seal materials can be provided. (Specify "TS," "TSS" or "TSL".)

Sealed SPHERE-ROL® bearings should not be subjected to operating misalignments greater than ±2° for best seal performance. During mounting and handling, the bearing should not be misaligned more than ±3°, to insure that seals do not become displaced. Sealed bearings contain snap rings mounted in the outer ring to limit the allowable bearing misalignment, so that the seals cannot be displaced from the bearing.

LAMBDA® seals

The LAMBDA® sealing arrangement is an optional seal configuration available in the SPHERE-ROL® bearing from McGill, for applications where contamination conditions are particularly severe. These would be applications where substantial amounts of moisture are present (such as direct splash of water) or where bearings operate submerged in dirt and/or dust. The sealing features of the standard NYLAPLATE® seal, used for many years in the SPHERE-ROL® bearing, are combined with the lip-wiping sealing function of an added contact seal, to form the LAMBDA® sealing arrangement. (Specify "YS", "YSS", or "YSL".)



LAMBDA® sealed SPHERE-ROL® bearings should not be operated at misalignment angles in excess of ±1° and for best seal efficiency, operating misalignment angles should not exceed ±1/2°. The LAMBDA® seal should not be operated at temperatures exceeding 300°F. Please consult the McGill Engineering Department when higher temperatures must be considered.

Expansion-type SPHERE-ROL® bearings

A special version of the SPHERE-ROL® bearing can be provided for applications requiring the bearing to accommodate expansion (float) internally. This "expansion-type" SPHERE-ROL® bearing is specified and identified by adding the suffix letter "E" immediately following the diametral clearance specification. (For instance, SB-22319-C3E.)

Most applications incorporating two bearings on a common shaft require that one of those bearings be "fixed" and that the other be free to "float," either in the housing seat.

ENGINEERING SECTION

bore or on the shaft seat. This float allowance, or expansion allowance, is required to compensate for variations in thermal expansion, or for linear dimension errors resulting from fabrication. In many cases, ordinary non-separable ball or roller bearings are used for expansion but they are unsatisfactory because of housing or shaft seat diameter tolerances, the application of heavy loads or misalignment. Self-aligning bearings are preferred and the expansion-type SPHERE-ROL® roller bearing is the only internally self-aligning bearing having the capability of accommodating expansion or float allowance internally.

This expansion-type SPHERE-ROL® bearing is dimensionally interchangeable, size for size, with "standard" spherical roller bearings; but, because of changes in internal geometry, it does provide substantial axial play of one race ring relative to the other. The expansion allowance in this type SPHERE-ROL® bearing is normally as much as the end play or expansion allowance that would be found in a non-locating cylindrical roller bearing.

The "E" type SPHERE-ROL® bearing is available with the same sealing advantages, diametral clearance values, tapered bore and outer ring relubrication features as standard bearings shown on pages 94 to 97. The basic dynamic rating of "E" type SPHERE-ROL® bearings is 10% less than standard SPHERE-ROL® bearings. Maximum seal misalignment is limited due to increased axial play in bearing.

The expansion-type SPHERE-ROL® bearing will not operate satisfactorily if subjected to thrust loading. Therefore, the expansion-type SPHERE-ROL® bearing must not be used in "fixed" ("held") positions—it is for use only in "expansion" ("float") positions. It is recommended that the end-wise restraint of both race rings of the expansion-type bearing be provided, so that the expansion allowance intended to be available is not lost by error in installation.

Diametral clearance

SPHERE-ROL® bearings are available in five internal diametral clearance ranges identified as C1, C2, Standard, C3 and C4. The C1 and C2 internal diametral clearances are progressively less than the Standard, while C3 and C4 are progressively looser than Standard.

Similarly, five internal clearance ranges are available for tapered bore SPHERE-ROL® bearings. Each of these ranges is somewhat looser than the corresponding cylindrical bore bearing internal diametral clearance range, because of the need to accommodate a somewhat tighter fit with the tapered bore mounting arrangement.

The following two charts give the internal diametral clearance ranges normally available with SPHERE-ROL® bearings from McGill.

Stock bearings having standard diametral clearance will not be identified by special marking; however, the C1, C2, C3 and C4 clearances will be identified on the bearing inner ring face, following the basic bearing number.

Radial clearance (inches) for "SB" Bearings with straight bores

BASIC BORE DIAMETER MM		RADIAL CLEARANCE IN INCHES							
		C2		STANDARD		C3		C4	
OVER	INCL.	MIN.	MAX.	MIN.	MAX.	MIN.	MAX.	MIN.	MAX.
14	24	.0004	.0008	.0008	.0014	.0014	.0018	.0018	.0024
24	30	.0006	.0010	.0010	.0016	.0016	.0022	.0022	.0028
30	40	.0006	.0012	.0012	.0018	.0018	.0024	.0024	.0032
40	50	.0008	.0014	.0014	.0022	.0022	.0030	.0030	.0039
50	65	.0010	.0017	.0017	.0026	.0026	.0036	.0036	.0047
65	80	.0012	.0020	.0020	.0032	.0032	.0044	.0044	.0057
80	100	.0014	.0025	.0025	.0039	.0039	.0053	.0053	.0071
100	120	.0017	.0031	.0031	.0048	.0048	.0064	.0064	.0083
120	140	.0020	.0038	.0038	.0057	.0057	.0075	.0075	.0095
140	160	.0024	.0043	.0043	.0065	.0065	.0087	.0087	.0110

Radial clearance (inches) for "SB" Bearings with tapered ("K" type) bore

BASIC BORE DIAMETER MM		RADIAL CLEARANCE IN INCHES							
		C2		STANDARD		C3		C4	
OVER	INCL.	MIN.	MAX.	MIN.	MAX.	MIN.	MAX.	MIN.	MAX.
14	24	.0006	.0010	.0010	.0014	.0014	.0018	.0018	.0024
24	30	.0008	.0012	.0012	.0017	.0017	.0022	.0022	.0030
30	40	.0008	.0014	.0014	.0020	.0020	.0026	.0026	.0034
40	50	.0012	.0018	.0018	.0024	.0024	.0032	.0032	.0041
50	65	.0014	.0022	.0022	.0030	.0030	.0039	.0039	.0049
65	80	.0018	.0028	.0028	.0037	.0037	.0049	.0049	.0061
80	100	.0020	.0032	.0032	.0044	.0044	.0057	.0057	.0075
100	120	.0025	.0039	.0039	.0053	.0053	.0069	.0069	.0089
120	140	.0030	.0047	.0047	.0063	.0063	.0081	.0081	.0102
140	160	.0034	.0051	.0051	.0071	.0071	.0091	.0091	.0118

Bearing mounting

Bearings should be mounted squarely when press fitted, either in housings or on shafts, and installation pressure should be applied to the press fitted member only, or should be evenly distributed over both members. When heavier shaft fits are encountered, it is sometimes advisable to heat the assembled bearing in order to prevent scoring of the shaft. Heat should not be applied directly to the bearing, but should be conducted to the bearing by some fluid medium. It is recommended that such heating be accomplished in mineral oil and that the temperature of the oil should not exceed 250°F. Sealed SPHERE-ROL® bearings should not be mounted by this method as the grease with which the bearings are prelubricated may be affected.

Shaft surfaces on which the bearing is to be mounted must be clean and free from nicks and burrs. Ground shaft finishes are normally suggested for applications involving SPHERE-ROL® bearings; however, in some cases, a ground finish is not practical. In these situations, a machined finish may be acceptable; consult the McGill Engineering Department for recommendations.

When stationary outer rings are required to float (move axially in the housing bore to compensate for expansion),

a housing bore surface finish of 65 micro inches Ra maximum is recommended.

Shaft and housing seat diameters

The tolerances, specified in the following charts for shaft and housing bearing seat fits, may be followed for specific application conditions that are encountered, as indicated. For special applications not covered by the following, the McGill Engineering Department should be consulted for additional assistance.

The proper shaft and housing seat tolerances are designated by a letter and number. For shafts, a lower case letter is used, and for housings, a capital letter, both indicating the location of the tolerance range in relation to the nominal bearing dimension. The numbers indicate the grade of accuracy.

The recommended shaft and housing fits depend upon the operating conditions, as indicated in the charts. In the right-hand column, the symbols for the recommended shaft and housing fits are given. The corresponding numerical dimension values are given on page 92 for the shaft fits, and on page 93 for the housing fits.

Housing seat fits

HOUSING CONSTRUCTION	OPERATING CONDITIONS		FIT SYMBOL*	REMARKS
Housing not split radially	Housing rotating relative to load direction	Heavy loads on bearing in thin wall housing	P7	The outer ring is not axially displaceable
		Normal and heavy loads	N7	
		Light loads	M7	
Housing split radially	The direction of the load indeterminate	Heavy shock loads	K7	The outer ring, as a rule, is not axially displaceable
		Heavy and normal loads axial displacement of outer ring not required		
Housing split or not split radially	Housing stationary relative to load direction	Normal and light loads axial displacement of outer ring desirable	J7	The outer ring, as a rule, is axially displaceable
		Shock loads, temporary complete unloading		
	All loads	Housing not split radially	H7	The outer ring is easily displaced axially.
		Housing split radially	H8	
Heat supplied through the shaft	G7			

* For cast iron or steel housing. For housings of light metal, tolerances are generally selected that give slightly tighter fits than those shown.

Shaft seat fits

OPERATING CONDITION		NOMINAL SHAFT DIA.		FIT SYMBOL
		MM	INCH	
Stationary inner ring relative to load direction All loads	Inner ring easily displaced	All diameters	All diameters	g6
	Inner ring not easily displaced	All diameters	All diameters	h6
Inner ring rotating relative to load direction, or load direction indeterminate	Radial load ≤ .08 BDR*	≤ 40 Over 40 to 100 Over 100 to 200	≤ 1.57 Over 1.57 to 3.94 Over 3.94 to 7.88	j6 k6 m6
	Radial load > .08 BDR* ≤ .18 BDR*	≤ 40 Over 40 to 65 Over 65 to 100 Over 100 to 140 Over 140 to 280	≤ 1.57 Over 1.57 to 2.56 Over 2.56 to 3.94 Over 3.94 to 5.52 Over 5.52 to 11.10	k5 m5 m6 n6 p6
	Radial load > .18 BDR*	≤ 40 Over 40 to 65 Over 65 to 100 Over 100 to 140 Over 140 to 200 Over 200 to 500	≤ 1.57 Over 1.57 to 2.56 Over 2.56 to 3.94 Over 3.94 to 5.52 Over 5.52 to 7.88 Over 7.88 to 19.69	m5 m6 n6 p6 r6 r7 Brgs. with greater than normal dia. clearance

* BDR — Bearing Basic Dynamic Rating

SB SERIES

Bearing shaft fits and tolerances

Table 1

FIT, INNER RING TO SHAFT		PUSH FIT				PUSH FIT TO WRINGING FIT				WRINGING FIT				DRIVE FIT				LIGHT FORCE FIT							
BEARING BORE DIAMETER		g6				h6				h5				j5				j6				k5			
MM	INCHES	SHAFT DIA. IN.		MEAN FIT	SHAFT DIA. IN.		MEAN FIT	SHAFT DIA. IN.		MEAN FIT	SHAFT DIA. IN.		MEAN FIT	SHAFT DIA. IN.		MEAN FIT	SHAFT DIA. IN.		MEAN FIT	SHAFT DIA. IN.		MEAN FIT			
		MAX.	MIN.		MAX.	MIN.		MAX.	MIN.		MAX.	MIN.		MAX.	MIN.		MAX.	MIN.		MAX.	MIN.		MAX.	MIN.	
15	.5906	.5903	.5903	.5899	.5906	.5902	.5906	.5903	.5906	.5903	.5906	.5905	.5905	.5909	.5905	.5909	.5910	.5907	.5910	.5907	.5907	.5907			
17	.6693	.6690	.6690	.6686	.6693	.6689	.6693	.6690	.6693	.6690	.6693	.6695	.6692	.6696	.6692	.6696	.6697	.6694	.6697	.6694	.6694	.6694			
20	.7874	.7870	.7871	.7866	.7874	.7869	.7874	.7870	.7874	.7870	.7874	.7876	.7872	.7877	.7872	.7877	.7879	.7875	.7879	.7875	.7875	.7875			
25	.9843	.9839	.9840	.9835	.9843	.9838	.9843	.9839	.9843	.9839	.9843	.9845	.9841	.9846	.9841	.9846	.9848	.9844	.9848	.9844	.9844	.9844			
30	1.1811	1.1807	1.1808	1.1803	1.1811	1.1806	1.1811	1.1807	1.1811	1.1807	1.1811	1.1813	1.1809	1.1814	1.1809	1.1814	1.1816	1.1812	1.1816	1.1812	1.1812	1.1812			
35	1.3780	1.3775	1.3776	1.3770	1.3780	1.3774	1.3780	1.3776	1.3780	1.3776	1.3780	1.3782	1.3778	1.3784	1.3778	1.3784	1.3785	1.3781	1.3785	1.3781	1.3781	1.3781			
40	1.5748	1.5743	1.5744	1.5738	1.5748	1.5742	1.5748	1.5744	1.5748	1.5744	1.5748	1.5750	1.5746	1.5752	1.5746	1.5752	1.5753	1.5749	1.5753	1.5749	1.5749	1.5749			
45	1.7717	1.7712	1.7713	1.7707	1.7717	1.7711	1.7717	1.7713	1.7717	1.7713	1.7717	1.7719	1.7715	1.7721	1.7715	1.7721	1.7722	1.7718	1.7722	1.7718	1.7718	1.7718			
50	1.9685	1.9680	1.9681	1.9675	1.9685	1.9679	1.9685	1.9681	1.9685	1.9681	1.9685	1.9687	1.9683	1.9689	1.9683	1.9689	1.9690	1.9686	1.9690	1.9686	1.9686	1.9686			
55	2.1654	2.1648	2.1650	2.1643	2.1654	2.1647	2.1654	2.1649	2.1654	2.1649	2.1654	2.1656	2.1651	2.1658	2.1651	2.1658	2.1660	2.1655	2.1660	2.1655	2.1655	2.1655			
60	2.3622	2.3616	2.3618	2.3611	2.3622	2.3615	2.3622	2.3617	2.3622	2.3617	2.3622	2.3624	2.3619	2.3626	2.3619	2.3626	2.3628	2.3623	2.3628	2.3623	2.3623	2.3623			
65	2.5591	2.5585	2.5587	2.5580	2.5591	2.5584	2.5591	2.5586	2.5591	2.5586	2.5591	2.5593	2.5588	2.5595	2.5588	2.5595	2.5597	2.5592	2.5597	2.5592	2.5592	2.5592			
70	2.7559	2.7553	2.7555	2.7548	2.7559	2.7552	2.7559	2.7554	2.7559	2.7554	2.7559	2.7561	2.7556	2.7563	2.7556	2.7563	2.7565	2.7560	2.7565	2.7560	2.7560	2.7560			
75	2.9528	2.9522	2.9524	2.9517	2.9528	2.9521	2.9528	2.9523	2.9528	2.9523	2.9528	2.9530	2.9525	2.9532	2.9525	2.9532	2.9534	2.9529	2.9534	2.9529	2.9529	2.9529			
80	3.1496	3.1490	3.1492	3.1485	3.1496	3.1489	3.1496	3.1491	3.1496	3.1491	3.1496	3.1498	3.1493	3.1500	3.1493	3.1500	3.1502	3.1497	3.1500	3.1497	3.1497	3.1497			
85	3.3465	3.3457	3.3459	3.3451	3.3465	3.3456	3.3465	3.3459	3.3465	3.3459	3.3465	3.3467	3.3461	3.3470	3.3461	3.3470	3.3472	3.3466	3.3470	3.3466	3.3466	3.3466			
90	3.5433	3.5425	3.5428	3.5419	3.5433	3.5424	3.5433	3.5427	3.5433	3.5427	3.5433	3.5435	3.5429	3.5438	3.5429	3.5438	3.5440	3.5434	3.5438	3.5434	3.5434	3.5434			
95	3.7402	3.7394	3.7397	3.7388	3.7402	3.7393	3.7402	3.7396	3.7402	3.7396	3.7402	3.7404	3.7398	3.7407	3.7398	3.7407	3.7409	3.7403	3.7407	3.7403	3.7403	3.7403			
100	3.9370	3.9362	3.9365	3.9356	3.9370	3.9361	3.9370	3.9364	3.9370	3.9364	3.9370	3.9372	3.9366	3.9375	3.9366	3.9375	3.9377	3.9371	3.9375	3.9371	3.9371	3.9371			
105	4.1339	4.1331	4.1334	4.1325	4.1339	4.1330	4.1339	4.1333	4.1339	4.1333	4.1339	4.1341	4.1335	4.1344	4.1335	4.1344	4.1346	4.1340	4.1344	4.1340	4.1340	4.1340			
110	4.3307	4.3299	4.3302	4.3293	4.3307	4.3298	4.3307	4.3301	4.3307	4.3301	4.3307	4.3309	4.3303	4.3312	4.3303	4.3312	4.3314	4.3308	4.3312	4.3308	4.3308	4.3308			
115	4.5276	4.5268	4.5271	4.5262	4.5276	4.5267	4.5276	4.5270	4.5276	4.5270	4.5276	4.5278	4.5272	4.5281	4.5272	4.5281	4.5283	4.5277	4.5281	4.5277	4.5277	4.5277			
120	4.7244	4.7236	4.7239	4.7230	4.7244	4.7235	4.7244	4.7238	4.7244	4.7238	4.7244	4.7246	4.7240	4.7249	4.7240	4.7249	4.7251	4.7245	4.7249	4.7245	4.7245	4.7245			
125	4.9213	4.9203	4.9207	4.9197	4.9213	4.9203	4.9213	4.9205	4.9213	4.9205	4.9213	4.9216	4.9209	4.9219	4.9209	4.9219	4.9221	4.9214	4.9219	4.9214	4.9214	4.9214			
130	5.1181	5.1171	5.1175	5.1165	5.1181	5.1171	5.1181	-	5.1181	-	5.1181	5.1184	5.1177	5.1187	5.1177	5.1187	5.1189	5.1182	5.1187	5.1182	5.1182	5.1182			
140	5.5118	5.5108	5.5112	5.5102	5.5118	5.5108	5.5118	-	5.5118	-	5.5118	5.5121	5.5114	5.5124	5.5114	5.5124	5.5126	5.5119	5.5124	5.5119	5.5119	5.5119			
150	5.9055	5.9045	5.9049	5.9039	5.9055	5.9045	5.9055	-	5.9055	-	5.9055	5.9058	5.9051	5.9061	5.9051	5.9061	5.9063	5.9056	5.9061	5.9056	5.9056	5.9056			

Table 2

FIT, INNER RING TO SHAFT		LIGHT FORCE FIT				FORCE FIT				HEAVY FORCE FIT																			
BEARING BORE DIAMETER		k6				m5				m6				n6				p6				r6				r7			
MM	INCHES	SHAFT DIA. IN.		MEAN FIT	SHAFT DIA. IN.		MEAN FIT	SHAFT DIA. IN.		MEAN FIT	SHAFT DIA. IN.		MEAN FIT	SHAFT DIA. IN.		MEAN FIT	SHAFT DIA. IN.		MEAN FIT	SHAFT DIA. IN.		MEAN FIT	SHAFT DIA. IN.		MEAN FIT	SHAFT DIA. IN.		MEAN FIT	
		MAX.	MIN.		MAX.	MIN.		MAX.	MIN.		MAX.	MIN.		MAX.	MIN.		MAX.	MIN.		MAX.	MIN.		MAX.	MIN.		MAX.	MIN.		MAX.
15	-	-	-	-	.5912	.5909	.5912	.5909	-	-	-	-	-	-	-	-	-	-	-	-	-	-	-	-	-	-	-	-	
17	-	-	-	-	.6699	.6696	.6699	.6696	-	-	-	-	-	-	-	-	-	-	-	-	-	-	-	-	-	-	-	-	
20	.7890	.7875	.7881	.7877	.9850	.9846	.9850	.9846	-	-	-	-	-	-	-	-	-	-	-	-	-	-	-	-	-	-	-	-	
25	.9849	.9844	.9849	.9844	1.1818	1.1814	1.1818	1.1814	-	-	-	-	-	-	-	-	-	-	-	-	-	-	-	-	-	-	-	-	
30	1.1817	1.1812	1.1817	1.1812	1.3788	1.3784	1.3788	1.3784	1.3790	1.3784	1.3790	1.3787	1.3787	1.3793	1.3787	1.3793	1.3788	1.3788	1.3793	1.3788	1.3788	1.3788	1.3788	1.3788	1.3788	1.3788	1.3788	1.3788	
35	1.3787	1.3781	1.3788	1.3784	1.5752	1.5752	1.5752	1.5752	1.5758	1.5752	1.5758	1.5755	1.5755	1.5761	1.5755	1.5761	1.5755	1.5755	1.5761	1.5755	1.5755	1.5755	1.5755	1.5755	1.5755	1.5755	1.5755	1.5755	
40	1.5755	1.5749	1.5755	1.5752	1.7727	1.7721	1.7727	1.7721	1.7727	1.7721	1.7727	1.7730	1.7724	1.7730	1.7724	1.7730	1.7724	1.7730	1.7724	1.7730	1.7724	1.7730	1.7724	1.7730	1.7724	1.7730	1.7724	1.7730	
45	1.7724	1.7718	1.7724	1.7718	1.9689	1.9689	1.9689	1.9689	1.9695	1.9689	1.9695	1.9692	1.9692	1.9698	1.9692	1.9698	1.9692	1.9698	1.9692	1.9698	1.9692	1.9698	1.9692	1.9698	1.9692	1.9698	1.9692	1.9698	
50	1.9692	1.9686	1.9692	1.9686	2.1666	2.1669	2.1666	2.1669	2.1666	2.1669	2.1666	2.1669	2.1669	2.1669	2.1669	2.1669	2.1669	2.1669	2.1669	2.1669	2.1669	2.1669	2.1669	2.1669	2.1669	2.1669	2.1669	2.1669	
55	2.1662	2.1655	2.1662	2.1655	2.3632	2.3627	2.3632	2.3627	2.3632	2.3627	2.3632	2.3637	2.3630	2.3637	2.3630	2.3637	2.3630	2.3637	2.3630	2.3637	2.3630	2.3637	2.3630	2.3637	2.3630	2.3637	2.3630	2.3637	
60	2.3630	2.3623	2.3630	2.3623	2.5601	2.5596	2.5601	2.5596	2.5601	2.5596	2.5601	2.5606	2.5599	2.5601	2.5599	2.5601	2.5599	2.5601	2.5599	2.5601	2.5599	2.5601	2.5599	2.5601	2.5599	2.5601	2.5599	2.5601	
65	2.5599	2.5592	2.5599	2.5592	2.7567	2.7564	2.7567	2.7564	2.7571	2.7564	2.7571	2.7567	2.7567	2.7574	2.7567	2.7574	2.7567	2.7574	2.7567	2.7574	2.7567	2.7574	2.7567	2.7574	2.7567	2.7574	2.7567	2.7574	
70	2.7567	2.7560	2.7567	2.7560	2.9536	2.9533	2.9536	2.9533	2.9540	2.9533	2.9540	2.9536	2.9536	2.9543	2.9536	2.9543	2.9536	2.9543	2.9536	2.9543	2.9536	2.9543	2.9536	2.9543	2.9536	2.9543	2.9536	2.9543	
75	2.9536	2.9529	2.9536	2.9529	3.1504	3.1501	3.1504	3.1501	3.1511	3.1501	3.1511	3.1504	3.1504	3.1511	3.1504	3.1511	3.1504	3.1511	3.1504	3.1511	3.1504	3.1511	3.1504	3.1511	3.1504	3.1511	3.1504	3.1511	
80	3.1504	3.1497	3.1504	3.1497	3.3476	3.3470	3.3476	3.3470	3.3479	3.3470	3.3479	3.3475	3.3475	3.3484	3.3475	3.3484	3.3475	3.3484	3.3475	3.3484	3.3475	3.3484	3.3475	3.3484	3.3475	3.3484	3.3475	3.3484	
85	3.3475	3.3466	3.3475	3																									

Bearing housing fits and tolerances

Table 3

FIT HSG. — OUTER RING			CLOSE RUNNING FIT				SLIDE FIT						PUSH FIT				WRINGING FIT			
BEARING OUTSIDE DIA.			G7				H8		H7		J7				J6		K6			
MM	INCHES		HOUSING BORE IN.		MEAN FIT	HOUSING BORE IN.		MEAN FIT	HOUSING BORE IN.		MEAN FIT	HOUSING BORE IN.		MEAN FIT	HOUSING BORE IN.		MEAN FIT	HOUSING BORE IN.		MEAN FIT
	MIN.	MAX.	MIN.	MAX.		MIN.	MAX.		MIN.	MAX.		MIN.	MAX.		MIN.	MAX.		MIN.	MAX.	
35	1.3775	1.3780	1.3784	1.3794		1.3780	1.3796		1.3780	1.3790		1.3776	1.3786		1.3778	1.3784		1.3775	1.3781	
37	1.4562	1.4567	1.4571	1.4581		1.4567	1.4583		1.4567	1.4577		1.4563	1.4573		1.4565	1.4571		1.4562	1.4568	
40	1.5743	1.5748	1.5752	1.5762	.0012L	1.5748	1.5764	.0011L	1.5748	1.5758	.0008L	1.5744	1.5754	.0004L	1.5746	1.5752	.0004L	1.5743	1.5749	.0000L
42	1.6530	1.6535	1.6539	1.6549		1.6535	1.6551		1.6535	1.6545		1.6531	1.6541		1.6533	1.6539		1.6530	1.6536	
47	1.8499	1.8504	1.8508	1.8518		1.8504	1.8520		1.8504	1.8514		1.8500	1.8510		1.8502	1.8508		1.8499	1.8505	
52	2.0467	2.0472	2.0476	2.0488		2.0472	2.0490		2.0472	2.0484		2.0468	2.0480		2.0470	2.0477		2.0466	2.0473	
62	2.4404	2.4409	2.4413	2.4425		2.4409	2.4427		2.4409	2.4421		2.4405	2.4417		2.4407	2.4414		2.4403	2.4410	
68	2.6767	2.6772	2.6776	2.6788	.0013L	2.6772	2.6790	.0012L	2.6772	2.6784	.0009L	2.6768	2.6780	.0005L	2.6770	2.6777	.0004L	2.6766	2.6773	.0000L
72	2.8341	2.8346	2.8350	2.8362		2.8346	2.8364		2.8346	2.8358		2.8342	2.8354		2.8344	2.8351		2.8340	2.8347	
75	2.9523	2.9528	2.9532	2.9544		2.9528	2.9546		2.9528	2.9540		2.9524	2.9536		2.9526	2.9533		2.9522	2.9529	
80	3.1491	3.1496	3.1500	3.1512		3.1496	3.1514		3.1496	3.1508		3.1492	3.1504		3.1494	3.1501		3.1490	3.1497	
85	3.3459	3.3465	3.3470	3.3484		3.3465	3.3487		3.3465	3.3479		3.3460	3.3474		3.3463	3.3472		3.3458	3.3467	
90	3.5427	3.5433	3.5438	3.5452		3.5433	3.5455		3.5433	3.5447		3.5428	3.5442		3.5431	3.5440		3.5426	3.5435	
95	3.7396	3.7402	3.7407	3.7421		3.7402	3.7424		3.7402	3.7416		3.7397	3.7411		3.7400	3.7409		3.7395	3.7404	
100	3.9364	3.9370	3.9375	3.9389	.0015L	3.9370	3.9392	.0014L	3.9370	3.9384	.0010L	3.9365	3.9379	.0005L	3.9368	3.9377	.0005L	3.9363	3.9372	.0001L
110	4.3301	4.3307	4.3312	4.3326		4.3307	4.3329		4.3307	4.3321		4.3302	4.3316		4.3305	4.3314		4.3300	4.3309	
115	4.5270	4.5276	4.5281	4.5295		4.5276	4.5298		4.5276	4.5290		4.5271	4.5285		4.5274	4.5283		4.5269	4.5278	
120	4.7238	4.7244	4.7249	4.7263		4.7244	4.7266		4.7244	4.7258		4.7239	4.7253		4.7242	4.7251		4.7237	4.7246	
125	4.9205	4.9213	4.9219	4.9235		4.9213	4.9238		4.9213	4.9229		4.9207	4.9223		4.9210	4.9220		4.9205	4.9215	
130	5.1173	5.1181	5.1187	5.1203		5.1181	5.1206		5.1181	5.1197		5.1175	5.1191		5.1178	5.1188		5.1173	5.1183	
140	5.5110	5.5118	5.5124	5.5140	.0018L	5.5118	5.5143	.0017L	5.5118	5.5134	.0012L	5.5112	5.5128	.0006L	5.5115	5.5125	.0006L	5.5110	5.5120	.0001L
145	5.7079	5.7087	5.7093	5.7109		5.7087	5.7112		5.7087	5.7103		5.7081	5.7097		5.7084	5.7094		5.7079	5.7089	
150	5.9047	5.9055	5.9061	5.9077		5.9055	5.9080		5.9055	5.9071		5.9049	5.9065		5.9052	5.9062		5.9047	5.9057	
160	6.2982	6.2992	6.2998	6.3014	.0019L	6.2992	6.3017	.0018L	6.2992	6.3008	.0013L	6.2986	6.3002	.0007L	6.2989	6.2999	.0007L	6.2984	6.2994	.0002L
170	6.6919	6.6929	6.6935	6.6951		6.6929	6.6954		6.6929	6.6945		6.6923	6.6939		6.6926	6.6936		6.6921	6.6931	
180	7.0856	7.0866	7.0872	7.0888		7.0866	7.0891		7.0866	7.0882		7.0860	7.0876		7.0863	7.0873		7.0858	7.0868	
190	7.4791	7.4803	7.4809	7.4827		7.4803	7.4831		7.4803	7.4821		7.4796	7.4814		7.4800	7.4812		7.4793	7.4805	
200	7.8728	7.8740	7.8746	7.8764		7.8740	7.8768		7.8740	7.8758		7.8733	7.8751		7.8737	7.8749		7.8730	7.8742	
210	8.2665	8.2677	8.2683	8.2701		8.2677	8.2705		8.2677	8.2695		8.2670	8.2688		8.2674	8.2686		8.2667	8.2679	
215	8.4634	8.4646	8.4652	8.4670		8.4646	8.4674		8.4646	8.4664		8.4639	8.4657		8.4643	8.4655		8.4636	8.4648	
220	8.6602	8.6614	8.6620	8.6638	.0021L	8.6614	8.6642	.0020L	8.6614	8.6632	.0015L	8.6607	8.6625	.0008L	8.6611	8.6623	.0009L	8.6604	8.6616	.0002L
225	8.8571	8.8583	8.8589	8.8607		8.8583	8.8611		8.8583	8.8601		8.8576	8.8594		8.8580	8.8592		8.8573	8.8585	
230	9.0539	9.0551	9.0557	9.0575		9.0551	9.0579		9.0551	9.0569		9.0544	9.0562		9.0548	9.0560		9.0541	9.0553	
240	9.4476	9.4488	9.4494	9.4512		9.4488	9.4516		9.4488	9.4506		9.4481	9.4499		9.4485	9.4497		9.4478	9.4490	
250	9.8413	9.8425	9.8431	9.8449		9.8425	9.8453		9.8425	9.8443		9.8418	9.8436		9.8422	9.8434		9.8415	9.8427	
260	10.2348	10.2362	10.2369	10.2389	.0024L	10.2362	10.2392	.0022L	10.2362	10.2382	.0017L	10.2355	10.2375	.0010L	10.2359	10.2371	.0010L	10.2352	10.2364	.0003L
270	10.6285	10.6299	10.6306	10.6326		10.6299	10.6329		10.6299	10.6319		10.6292	10.6312		10.6296	10.6308		10.6289	10.6301	

Table 4

FIT, HSG. TO OUTER RING			WRINGING FIT				DRIVE FIT				HEAVY DRIVE FIT				LIGHT FORCE FIT			
BEARING OUTSIDE DIA.			K7				M6		M7		N6		N7		P6		P7	
MM	INCHES		HOUSING BORE IN.		MEAN FIT	HOUSING BORE IN.		HOUSING BORE IN.		HOUSING BORE IN.		HOUSING BORE IN.		HOUSING BORE IN.		HOUSING BORE IN.		
	MIN.	MAX.	MIN.	MAX.		MIN.	MAX.	MIN.	MAX.	MIN.	MAX.	MIN.	MAX.	MIN.	MAX.	MIN.	MAX.	
35	1.3773	1.3783			.0001L	1.3772	1.3778		1.3770	1.3780		1.3769	1.3775		1.3766	1.3772		
37	1.4560	1.4570				1.4559	1.4565	.0003T	1.4557	1.4567	.0003T	1.4556	1.4562		1.4553	1.4559		
40	1.5741	1.5751				1.5740	1.5746		1.5738	1.5748		1.5737	1.5743	.0006T	1.5735	1.5741	.0006T	
42	1.6528	1.6538				1.6527	1.6533		1.6525	1.6535		1.6524	1.6530		1.6521	1.6527		
47	1.8497	1.8507				1.8496	1.8502		1.8494	1.8504		1.8493	1.8499		1.8490	1.8496		
52	2.0464	2.0476				2.0462	2.0469		2.0460	2.0472		2.0459	2.0466		2.0457	2.0463		
62	2.4401	2.4413				2.4399	2.4406		2.4397	2.4409		2.4396	2.4403		2.4394	2.4406		
68	2.6764	2.6776	.0000			2.6762	2.6769	.0004T	2.6760	2.6772	.0003T	2.6759	2.6766	.0007T	2.6757	2.6769	.0007T	
72	2.8338	2.8350				2.8336	2.8343		2.8334	2.8346		2.8333	2.8340		2.8331	2.8343		
75	2.9520	2.9532				2.9518	2.9525		2.9516	2.9528		2.9515	2.9522		2.9513	2.9525		
80	3.1488	3.1500				3.1486	3.1493		3.1484	3.1496		3.1483	3.1490		3.1481	3.1493		
85	3.3455	3.3469				3.3453	3.3462		3.3451	3.3465		3.3449	3.3458		3.3447	3.3461		
90	3.5423	3.5437				3.5421	3.5430		3.5419	3.5433		3.5417	3.5426		3.5415	3.5429		
95	3.7391	3.7405				3.7389	3.7399		3.7387	3.7401		3.7386	3.7395		3.7384	3.7398		
100	3.9360	3.9374	.0000			3.9358	3.9367	.0004T	3.9356	3.9370	.0004T	3.9354	3.9363	.0009T	3.9352	3.9366	.0008T	
110	4.3297	4.3311				4.3295	4.3304		4.3293	4.3307		4.3291	4.3300		4.3289	4.3303		
115	4.5266	4.5280				4.5264	4.5273		4.5262	4.5276		4.5260	4.5269		4.5258	4.5272		
120	4.7234	4.7248				4.7232	4.7241		4.7230	4.7244		4.7228	4.7237		4.7226	4.7240		
125	4.9202	4.9218				4.9200	4.9218		4.9197	4.9213		4.9194	4.9204		4.9191	4.9207		
130	5.1170	5.1186				5.1168	5.1178		5.1165	5.1181		5.1162	5.1172		5.1159	5.1175		
140	5.5107	5.5123	.0001L			5.5105	5.5115	.0004T	5.5102	5.5118	.0004T	5.5099	5.5109	.0010T	5.5096	5.5112	.0010T	
145	5.7076	5.7092				5.7074	5.7084		5.7071	5.7087		5.7068	5.7078		5.7065	5.7081		
150	5.9044	5.9060				5.9042	5.9052		5.9039	5.9055		5.9036	5.9046		5.9033	5.9049		
160	6.2981	6.2997				6.2979	6.2989		6.2976	6.2992		6.2973	6.2983		6.2970	6.2986		
170	6.6918	6.																

SB 22200 SERIES

Specify LAMBDA® seals for extra protection

LAMBDA® Seals provide an extra element which adds a lip-wiping and grease dam function to the standard effectiveness of a NYLAPLATE® Seal. LAMBDA® Seals are recommended for applications where the bearing is exposed to conditions, such as splashed liquids or immersion in dust or dirt. See page 89 for engineering considerations and note 9 on next page for bearing identification.



"E" expansion type bearings

A special version of the SPHERE-ROL® bearing can be provided for applications requiring the bearing to accommodate expansion or float internally. See 89 page for engineering details and note 10 on next page for identification.

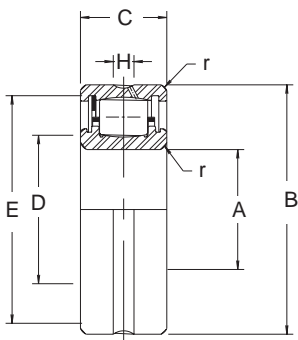

STRAIGHT BORE

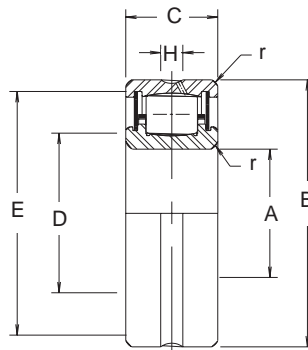

SEALED

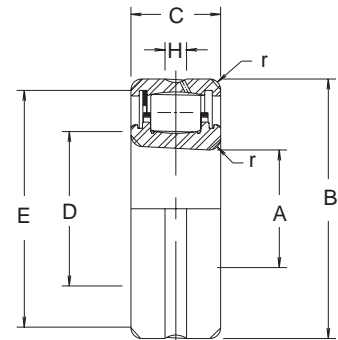

TAPERED BORE

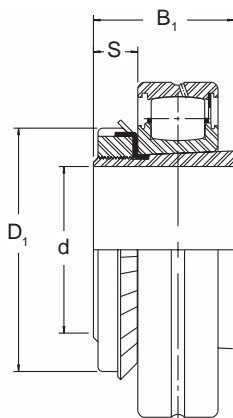

TAPERED BORE WITH ADAPTER

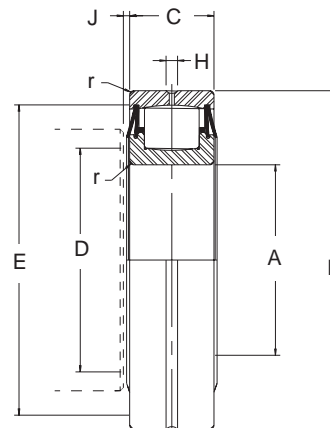

LAMBDA® SEALS

McGILL BEARING NUMBER	BORE A			OUTSIDE DIAMETER B			WIDTH C			r (1)	SHOULDER DIMENSIONS		H (2)	J MIN.	LIM. SPEED (3) RPM	ABMA BASIC DYNAMIC RATING POUNDS	ADAPTER NUMBER (4)	ADAPTER DIMENSIONS				(5) BRG. WT. LBS.
	MM	INCH	TOL. +.0000	MM	INCH	TOL. +.0000	MM	INCH	TOL. +.0000		D	E						SHAFT DIAM.	B ₁	S	D ₁	
											INCH	INCH										
†SB-22202	15	.5906	-.0003	35	1.3780		14	.5512		.024	23/32	1 3/16	3/32	3/32	14000	3900	-	-	-	-	.15	
†SB-22203	17	.6693		40	1.5748		16	.6299		.024	15/16	1 3/8	1/8	3/32	13000	5000	-	-	-	-	.20	
SB-22204	20	.7874		47	1.8504		18	.7087		.039	1	1 5/8	1/8	3/32	11000	7000	-	-	-	-	.32	
SB-22205	25	.9843	-.0004	52	2.0472	-.0005	18	.7087		.039	1 7/32	1 13/16	5/32	3/32	9000	8100	SNW 05	3/4	1 17/64	29/64	1 9/16	.40
SB-22206	30	1.1811		62	2.4409		20	.7874	-.0050	.039	1 7/16	2 3/16	5/32	3/32	8100	11500	SNW 06	15/16	1 23/64	29/64	1 3/4	.64
SB-22207	35	1.3780		72	2.8346		23	.9055		.039	1 5/8	2 7/16	11/64	3/32	6800	15100	SNW 07	1 3/16	1 29/64	31/64	2 1/16	.95
SB-22208	40	1.5748		80	3.1496		23	.9055		.039	1 7/8	2 3/4	11/64	3/32	6000	16800	SNW 08	1 5/16	1 1/2	1/2	2 1/4	1.20
SB-22209	45	1.7717		85	3.3465		23	.9055		.039	2 1/16	2 15/16	11/64	3/32	5600	17800	SNW 09	1 7/16	1 37/64	1/2	2 17/32	1.30
SB-22210	50	1.9685		90	3.5433		23	.9055		.039	2 1/4	3 1/8	11/64	3/32	5250	18700	SNW 10	1 11/16	1 49/64	9/16	2 11/16	1.40
SB-22211	55	2.1654		100	3.9370	-.0006	25	.9843		.059	2 1/2	3 1/2	11/64	3/32	4650	23000	SNW 11	1 15/16	1 27/32	9/16	2 31/32	1.90
SB-22212	60	2.3622		110	4.3307		28	1.1024		.059	2 3/4	3 7/8	11/64	3/32	4200	29200	-	-	-	-	2.60	
SB-22213	65	2.5591		120	4.7244		31	1.2205	-.0060	.059	2 15/16	4 3/16	3/16	1/8	3800	35500	SNW 13	2 3/16	2 7/64	5/8	3 3/8	3.40
†SB-22214	70	2.7559		125	4.9213		31	1.2205		.059	3 1/8	4 7/16	3/16	1/8	3650	35900	-	-	-	-	3.60	
SB-22215	75	2.9528		130	5.1181	-.0008	31	1.2205		.059	3 5/16	4 5/8	3/16	1/8	3500	37600	SNW 15	2 7/16	2 19/64	43/64	3 7/8	3.90
SB-22216	80	3.1496		140	5.5118		33	1.2992		.079	3 9/16	4 15/16	7/32	1/8	3250	42400	SNW 16	2 11/16	2 3/8	43/64	4 5/32	4.60
SB-22217	85	3.3465		150	5.9055		36	1.4173		.079	3 3/4	5 5/16	7/32	1/8	3000	50900	SNW 17	2 15/16	2 31/64	45/64	4 13/32	5.90
SB-22218	90	3.5433		160	6.2992		40	1.5748		.079	3 15/16	5 11/16	7/32	1/8	2800	59200	SNW 18	3 3/16	2 41/64	25/32	4 21/32	7.50
SB-22219	95	3.7402		170	6.6929	-.0010	43	1.6929		.079	4 3/16	6 1/16	21/64	1/8	2650	70900	-	-	-	-	9.20	
SB-22220	100	3.9370		180	7.0866		46	1.8110	-.0080	.079	4 7/16	6 3/8	21/64	1/8	2500	77700	SNW 20	3 7/16	2 7/8	27/32	5 3/16	11.10
SB-22222	110	4.3307		200	7.8740		53	2.0866		.079	4 7/8	7 1/8	21/64	1/8	2200	100000	SNW 22	3 15/16	3 13/64	29/32	5 23/32	15.90
SB-22224	120	4.7244		215	8.4646	-.0012	58	2.2835		.079	5 5/16	7 11/16	7/16	3/16	2050	120000	SNW 24	4 3/16	3 15/32	15/16	6 1/8	19.80
SB-22226	130	5.1181		230	9.0551		64	2.5197		.098	5 7/8	8 5/16	7/16	3/16	1900	132500	SNW 26	4 7/16	3 49/64	1	6 3/4	24.80
SB-22228	140	5.5118	-.0010	250	9.8425		68	2.6772	-.0100	.098	6 1/4	9 1/16	7/16	3/16	1750	159100	SNW 28	4 15/16	3 63/64	1 1/16	7 3/32	31.30
SB-22230	150	5.9055		270	10.6299	-.0014	73	2.8740		.098	6 11/16	9 11/16	35/64	3/16	1600	169300	SNW 30	5 3/16	4 15/64	1 1/8	7 11/16	39.50

† Not available from stock. Consult McGill Customer Service for availability.

- r = maximum fillet radius for shaft and housing.
- All sizes supplied with outer ring relubrication feature (-W33) unless otherwise specified. Consult McGill Customer Service for availability of non-W33.
- Refers to oil lubrication and moderate load. For grease lubrication, use 1/2 of value shown.
- Complete adapter number indicates adapter sleeve, locknut and lock washer (Example — Adapter Number SNW 07 indicates sleeve S-07, locknut N-07 and lock washer W-07.) Sizes SB-22202 through SB-22211 and SB-22214 and SB-22215, standard ABMA locknuts and lockwashers will not clear LAMBDA seal I.D. unless 1/16" thick spacer is used between face of bearing and washer (or locknut).
- Does not include adapter assembly.
- Add suffix "K" to indicate tapered bore bearing.
- Add suffix "-W22" for selected O.D.
- Add suffix "S" to bearing number for single seal and "SS" for double seals. For tapered bore bearings using single seal, add suffix "S" to indicate seal on small bore side and "SL" to indicate seal on large bore side. For high temp. seals, use "TS", "TSS" or "TSL", and high temp. grease.
- For LAMBDA® seals, add suffix "YS" to bearing number for single seal and "YSS" for double seals. For tapered bore bearings, single LAMBDA® sealed, add suffix "YS" to indicate seal on small bore side and "YSL" to indicate seal on large bore side.
- For expansion-type bearing, add suffix "E" to catalog number immediately after diametral clearance specifications.

SB 22300 SERIES

Specify LAMBDA® seals for extra protection

LAMBDA® Seals provide an extra element which adds a lip-wiping and grease dam function to the standard effectiveness of a NYLAPLATE® Seal. LAMBDA® Seals are recommended for applications where the bearing is exposed to conditions, such as splashed liquids or immersion in dust or dirt. See page 89 for engineering considerations and note 9 on next page for bearing identification.



"E" expansion type bearings

A special version of the SPHERE-ROL® bearing can be provided for applications requiring the bearing to accommodate expansion or float internally. See 89 page for engineering details and note 10 on next page for identification.

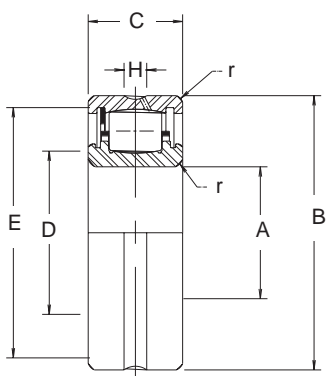

STRAIGHT BORE

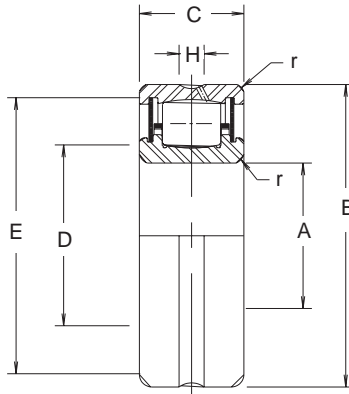

SEALED

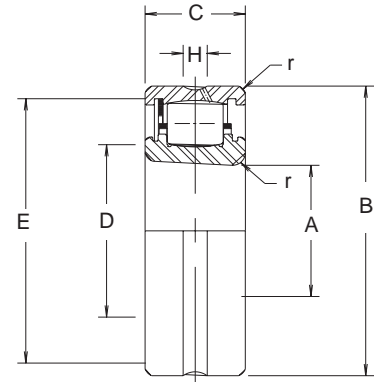

TAPERED BORE

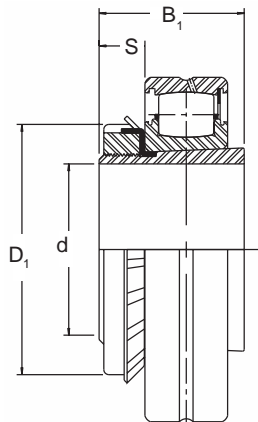

TAPERED BORE WITH ADAPTER

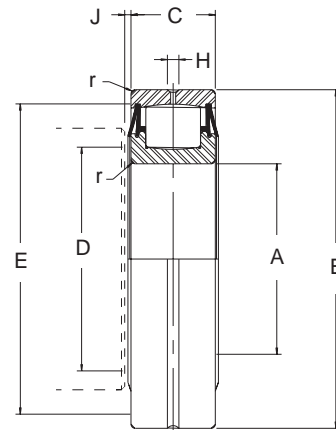

LAMBDA® SEALS

McGILL BEARING NUMBER	BORE A			OUTSIDE DIAMETER B			WIDTH C			r (1)	SHOULDER DIMENSIONS		H (2)	J MIN.	LIM. * SPEED (3) RPM	ABMA BASIC DYNAMIC RATING POUNDS	ADAPTER NUMBER (4)	ADAPTER DIMENSIONS				(5) BRG. WT. LBS.
	MM	INCH	TOL. +.0000	MM	INCH	TOL. +.0000	MM	INCH +.0000	TOL. +.0000		D	E						SHAFT DIAM.	B ₁	S	D ₁	
											INCH	INCH										
SB-22308	40	1.5748		90	3.5433		33	1.2992		.059	1 15/16	3 1/8	7/32	3/32	5250	25600	-	-	-	-	-	2.3
SB-22309	45	1.7717	-.0005	100	3.9370		36	1.4173	-.0050	.059	2 1/8	3 1/2	1/4	3/32	4650	30100	SNW 109	1 7/16	2 9/64	1/2	2 17/32	3.1
SB-22310	50	1.9685		110	4.3307		40	1.5748		.079	2 3/8	3 7/8	1/4	3/32	4200	37400	SNW 110	1 11/16	2 25/64	9/16	2 11/16	4.1
SB-22311	55	2.1654		120	4.7244		43	1.6929		.079	2 9/16	4 1/4	21/64	1/8	3800	41300	SNW 111	1 15/16	2 33/64	9/16	2 31/32	5.3
SB-22312	60	2.3622		130	5.1181		46	1.8110		.079	2 13/16	4 9/16	21/64	1/8	3500	54700	-	-	-	-	-	6.6
SB-22313	65	2.5591		140	5.5118	-.0008	48	1.8898		.079	3	4 15/16	21/64	1/8	3250	59700	SNW 113	2 3/16	2 49/64	5/8	3 3/8	7.8
SB-22314	70	2.7559		150	5.9055		51	2.0079		.079	3 1/4	5 3/8	21/64	1/8	3000	68400	-	-	-	-	-	9.5
SB-22315	75	2.9528		160	6.2992		55	2.1654		.079	3 7/16	5 3/8	21/64	1/8	2800	74800	SNW 115	2 7/16	3 5/64	43/64	3 7/8	11.9
SB-22316	80	3.1496		170	6.6929	-.0010	58	2.2835		.079	3 5/8	6 1/16	21/64	1/8	2650	77500	SNW 116	2 11/16	3 13/64	43/64	4 5/32	13.9
SB-22317	85	3.3465		180	7.0866		60	2.3622		.098	3 7/8	6 7/16	21/64	1/8	2500	95100	SNW 117	2 15/16	3 5/16	45/64	4 13/32	16.2
SB-22318	90	3.5433	-.0008	190	7.4803		64	2.5197	-.0080	.098	4 1/8	6 3/4	7/16	1/8	2350	98400	SNW 118	3 3/16	3 35/64	25/32	4 21/32	19.2
SB-22319	95	3.7402		200	7.8740	-.0012	67	2.6378		.098	4 3/8	7 1/16	7/16	5/32	2200	109400	-	-	-	-	-	22.7
SB-22320	100	3.9370		215	8.4646		73	2.8740		.098	4 5/8	7 11/16	7/16	3/16	2050	128800	SNW 120	3 7/16	3 31/32	27/32	5 3/16	28.4

- r = maximum fillet radius for shaft and housing.
- All sizes supplied with outer ring relubrication feature (-W33) unless otherwise specified. Consult McGill Customer Service for availability of non-W33.
- Refers to oil lubrication and moderate load. For grease lubrication, use 1/2 of value shown.
- Complete adapter number indicates adapter sleeve, locknut and lock washer (Example — Adapter Number SNW 109 indicates sleeve S-109, locknut N-09 and lock washer W-09.)
- Does not include adapter assembly.
- Add suffix "K" to indicate tapered bore bearing.
- Add suffix "-W22" for selected O.D.
- Add suffix "S" to bearing number for single seal and "SS" for double seals. For tapered bore bearings using single seal, add suffix "S" to indicate seal on small bore side and "SL" to indicate seal on large bore side. For high temp. seals, use "TS", "TSS" OR "TSL", and high temp. grease.
- For LAMBDA® seals, add suffix "YS" to bearing number for single seal and "YSS" for double seals. For tapered bore bearings, single LAMBDA® sealed, add suffix "YS" to indicate seal on small bore side and "YSL" to indicate seal on large bore side.
- For expansion-type bearing, add suffix "E" to catalog number immediately after diametral clearance specifications.

INTERCHANGEABILITY CHART

22200 series

STRAIGHT BORE					TAPERED BORE				
* FAG®	* TORRINGTON®	* SKF®	LINK BELT	McGILL	* FAG®	* TORRINGTON®	* SKF®	LINK BELT	McGILL
				SB-22204					SB-22204-K
22205	22205	22205-CC		SB-22205	22205K	22205K	22205-CCK		SB-22205-K
22206	22206	22206-CC		SB-22206	22206K	22206K	22206-CCK		SB-22206-K
22207	22207	22207-CC		SB-22207	22207K	22207K	22207-CCK		SB-22207-K
22208	22208	22208-CC		SB-22208	22208K	22208K	22208-CCK		SB-22208-K
22209	22209	22209-CC	22209LB	SB-22209	22209K	22209K	22209-CCK	22209LBK	SB-22209-K
22210	22210	22210-CC	22210LB	SB-22210	22210K	22210K	22210-CCK	22210LBK	SB-22210-K
22211	22211	22211-CC	22211LB	SB-22211	22211K	22211K	22211-CCK	22211LBK	SB-22211-K
22212	22212	22212-CC	22212LB	SB-22212	22212K	22212K	22212-CCK	22212LBK	SB-22212-K
22213	22213	22213-CC	22213LB	SB-22213	22213K	22213K	22213-CCK	22213LBK	SB-22213-K
22214	22214	22214-CC	22214LB	SB-22214	22214K	22214K	22214-CCK	22214LBK	SB-22214-K
22215	22215	22215-CC	22215LB	SB-22215	22215K	22215K	22215-CCK	22215LBK	SB-22215-K
22216	22216	22216-CC	22216LB	SB-22216	22216K	22216K	22216-CCK	22216LBK	SB-22216-K
22217	22217	22217-CC	22217LB	SB-22217	22217K	22217K	22217-CCK	22217LBK	SB-22217-K
22218	22218	22218-CC	22218LB	SB-22218	22218K	22218K	22218-CCK	22218LBK	SB-22218-K
22219	22219	22219-CC	22219LB	SB-22219	22219K	22219K	22219-CCK	22219LBK	SB-22219-K
22220	22220	22220-CC	22220LB	SB-22220	22220K	22220K	22220-CCK	22220LBK	SB-22220-K
22222	22222	22222-CC	22222LB	SB-22222	22222K	22222K	22222-CCK	22222LBK	SB-22222-K
22224	22224	22224-CC	22224LB	SB-22224	22224K	22224K	22224-CCK	22224LBK	SB-22224-K
22226	22226	22226-CC	22226LB	SB-22226	22226K	22226K	22226-CCK	22226LBK	SB-22226-K
22228	22228	22228-CC	22228LB	SB-22228	22228K	22228K	22228-CCK	22228LBK	SB-22228-K
22230	22230	22230-CC	22230LB	SB-22230	22230K	22230K	22230-CCK	22230LBK	SB-22230-K

22300 series

STRAIGHT BORE					TAPERED BORE				
FAG	* TORRINGTON®	* SKF®	LINK BELT	McGILL	* FAG®	* TORRINGTON®	* SKF®	LINK BELT	McGILL
22308	22308	22308-CC	22308LB	SB-22308	22308K	22308-K	22308-CCK	22308LBK	SB-22308-K
22309	22309	22309-CC	22309LB	SB-22309	22309K	22309-K	22309-CCK	22309LBK	SB-22309-K
22310	22310	22310-CC	22310LB	SB-22310	22310K	22310-K	22310-CCK	22310LBK	SB-22310-K
22311	22311	22311-CC	22311LB	SB-22311	22311K	22311-K	22311-CCK	22311LBK	SB-22311-K
22312	22312	22312-CC	22312LB	SB-22312	22312K	22312-K	22312-CCK	22312LBK	SB-22312-K
22313	22313	22313-CC	22313LB	SB-22313	22313K	22313-K	22313-CCK	22313LBK	SB-22313-K
22314	22314	22314-CC	22314LB	SB-22314	22314K	22314-K	22314-CCK	22314LBK	SB-22314-K
22315	22315	22315-CC	22315LB	SB-22315	22315K	22315-K	22315-CCK	22315LBK	SB-22315-K
22316	22316	22316-CC	22316LB	SB-22316	22316K	22316-K	22316-CCK	22316LBK	SB-22316-K
22317	22317	22317-CC	22317LB	SB-22317	22317K	22317-K	22317-CCK	22317LBK	SB-22317-K
22318	22318	22318-CC	22318LB	SB-22318	22318K	22318-K	22318-CCK	22318LBK	SB-22318-K
22319	22319	22319-CC	22319LB	SB-22319	22319K	22319-K	22319-CCK	22319LBK	SB-22319-K
22320	22320	22320-CC	22320LB	SB-22320	22320K	22320-K	22320-CCK	22320LBK	SB-22320-K
22322	22322	22322-CC	22322LB	SB-22322	22322K	22322-K	22322-CCK	22322LBK	SB-22322-K
22324	22324	22324-CC	22324LB	SB-22324	22324K	22324-K	22324-CCK	22324LBK	SB-22324-K
22326	22326	22326-CC	22326LB	SB-22326	22326K	22326-K	22326-CCK	22326LBK	SB-22326-K

* The trademark FAG is a registered trademark of Kugelfischer Georg Schafer & Co.
 The trademark TORRINGTON is a registered trademark of The Torrington Company.
 The trademark SKF is a registered trademark of SKF Industries, Inc.

Back-up or edge roller - steel mill continuous caster

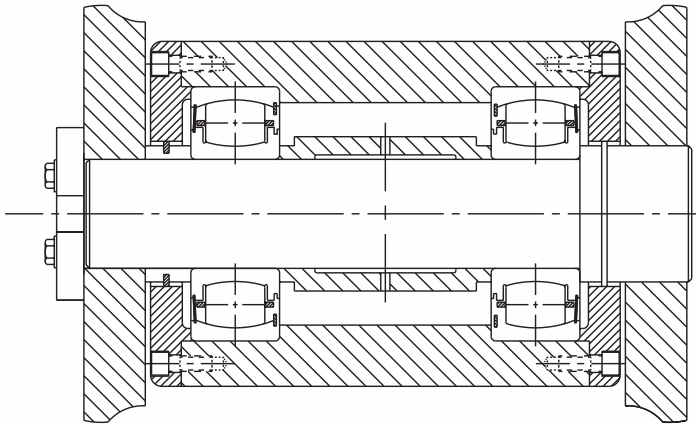

A single NYLAPLATE® seal (high temperature resistant material used when necessary) in each bearing, used in conjunction with piston ring sealing, helps protect against the contamination. High dynamic capacity in any size provides, with the integral sealing, improved life in these critical applications.

Hold down roll electrolytic tinning line

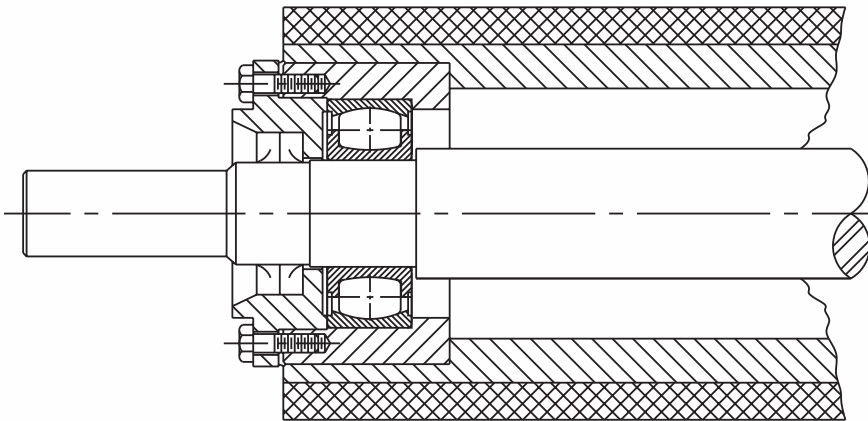

SPHERE-ROL® bearings with two integral NYLAPLATE® seals have increased bearing life in this application. Integral NYLAPLATE® seals, used in combination with standard external sealing arrangements, helps prevent entrance of chemical contamination, which causes premature failure of non-sealed bearings of another design.

Runout table roller

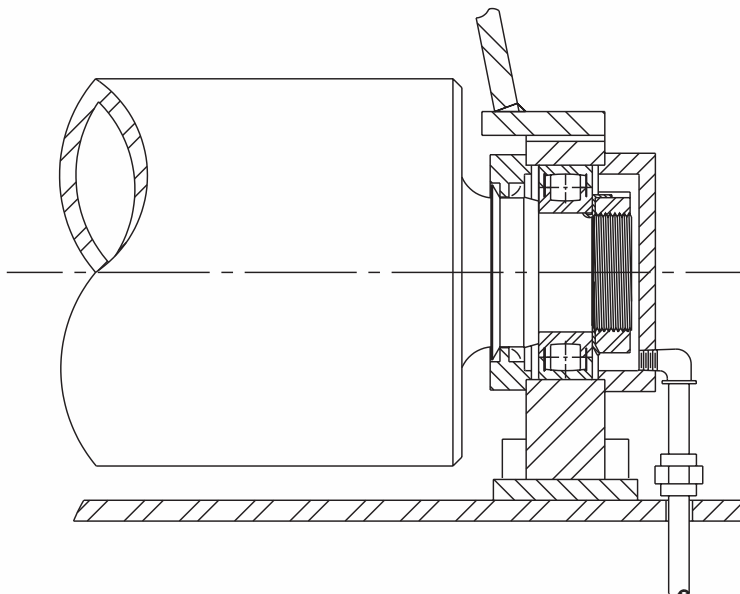

Integral NYLAPLATE® seal is used to back up commercial sealing in this metal mill table roller application. This seal arrangement, in combination with the slinger shown, helps reduce coolant and scale contamination of bearings. High dynamic capacity of the SPHERE-ROL® bearing increases bearing life in this shock loaded application.

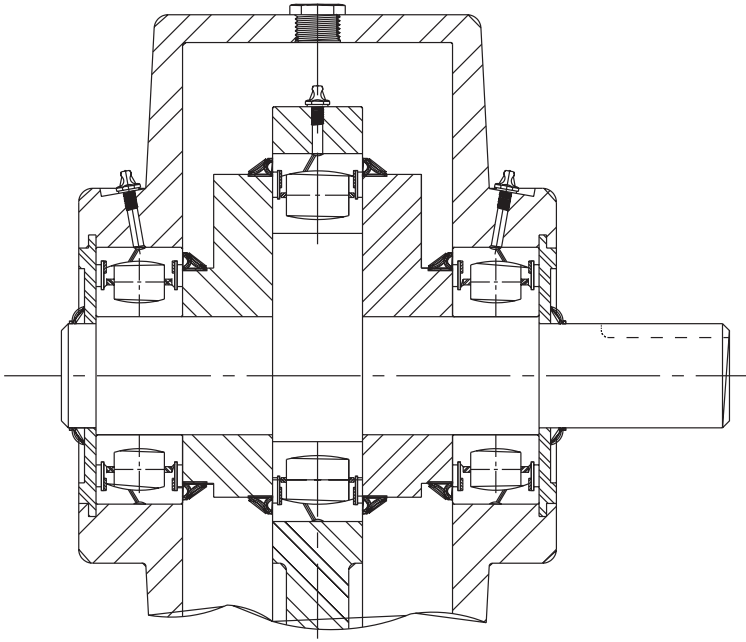

Pump application

Sealed SPHERE-ROL® bearings are used at the crankshaft supports and eccentric drive position of this piston pump. High capacity SPHERE-ROL® bearings are used for longer life and reduce maintenance. Commercial seals are backed up by the integral NYLAPLATE® seals in order to help reduce contamination of the pump.

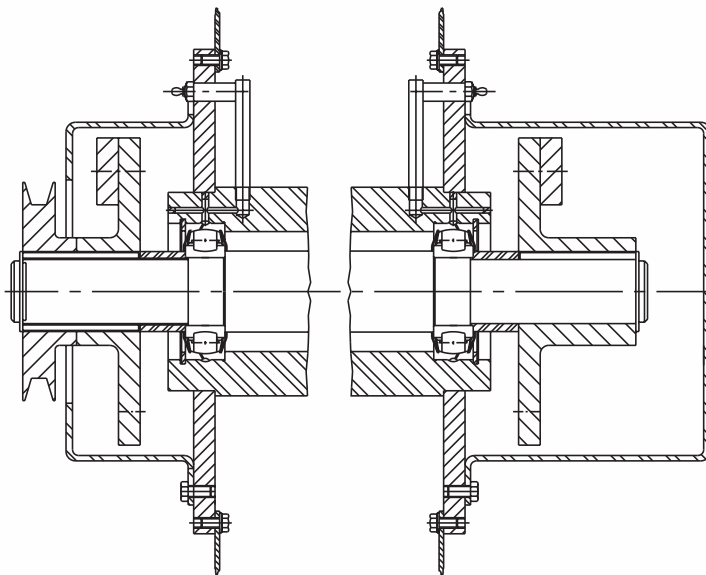

Vibratory application

Because of the lightweight, case-hardened steel cage, standard SPHERE-ROL® bearings perform well in vibratory applications. LAMBDA® seals help reduce severe contamination.

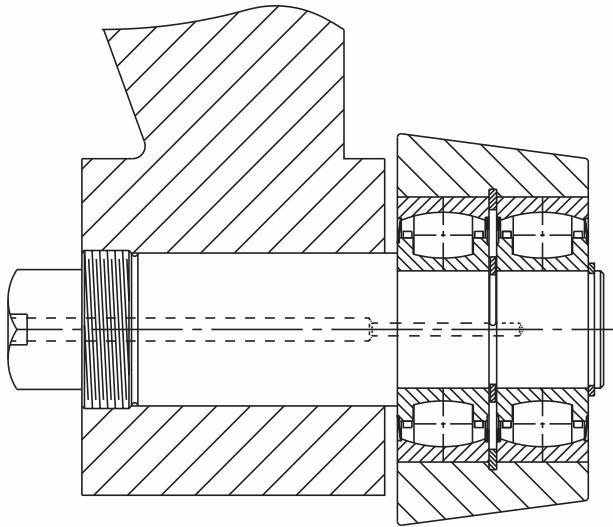

Hook roller — truck mounted crane

Matched pair of single-sealed SPHERE-ROL® bearings eliminates need for external sealing arrangement, provides increased load carrying capacity and carries thrust reactions without auxiliary thrust support arrangements. Crane capacity can be increased because of higher capacity of SPHERE-ROL® bearing.

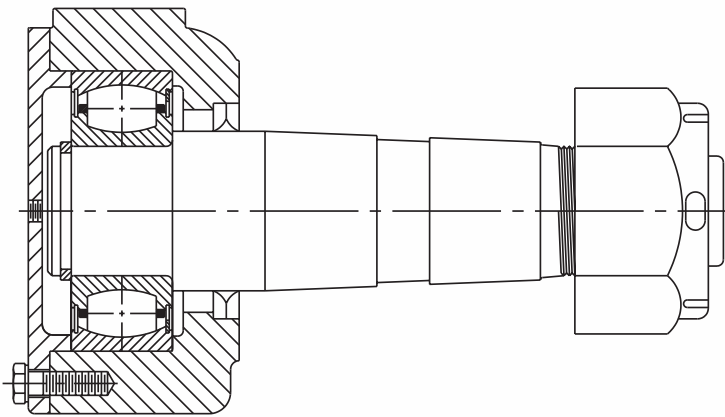

Oil field pumping unit crank pin bearing

SPHERE-ROL® bearings provide improved life even though initial mounting and dynamic misalignment are encountered. Special, large bore corner on inner ring allows larger neck fillet, thereby reducing neck stresses.

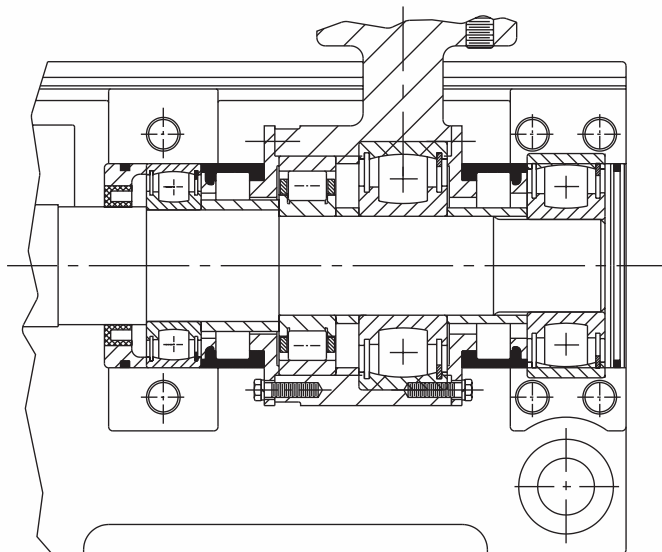

Concrete block machine

SPHERE-ROL® bearings support eccentric shaft that provides mechanical vibration of mold for compacting material. SPHERE-ROL® bearing also mounted directly in line with load reaction through rod, transmitting vibrating motion and loads. Increased bearing life is obtained, with cooler operating temperatures.

Bearing selection

Aircraft bearings from McGill meet aircraft specifications and aircraft quality standards.

NBC series bearings are designed for applications where the bearing O.D. can be supported in a housing and are suitable for slow rotating or oscillating applications only.

NBE and NBK series bearings are for housing-supported applications with slow rotation or oscillating motions only. If properly mounted, they will accommodate $\pm 5^\circ$ misalignment using a self-aligning adapter ring.

NBF, NBL, AFC and AL series bearings are for use in applications where the bearing O.D. is unsupported and will support heavy rolling loads in cam- or track-support applications.

Aircraft static capacity:

Aircraft static capacity (ASC) is the maximum load which can be placed on a housing-mounted, needle roller bearing without seriously brinelling the raceways (approximately .0001" depth) or deforming the rollers.

Load rating:

The aircraft static capacity listed for the NBC, NBE and NBK bearings corresponds to the ultimate static load rating. The "limit load" rating, which is the maximum static load that can be applied without impairing subsequent dynamic operation, is $\frac{2}{3}$ ASC.

In the case of the NBF, NBL, AFC and AL bearings, the ultimate static load rating is reduced to $\frac{2}{3}$ ASC because of the unsupported outer ring. The "limit load" rating listed is the maximum static load that can be applied without impairing subsequent dynamic operation. The dynamic rating for these bearings is listed as "capacity as a track roller" and is $\frac{1}{3}$ ASC. "Capacity as a track roller" is based on the applied dynamic load for an L_{10} life of 20,000 revolutions.

Temperature:

The unsealed aircraft bearings can be operated at a maximum temperature of 400°F., provided a suitable lubricant is used. Exposure to higher temperature will result in loss of capacity due to reduction in material hardness.

In the event bearings for higher temperature environment are required, consult McGill Engineering Department.

The maximum continuous operating temperature for sealed bearings is 250°F. and is limited by the seal material.

Lubrication:

Normally, all aircraft bearings from McGill are pre-lubricated with grease per MIL-G-23827 which has a safe operating range of -100°F. to +250°F. However, special lubricants may be substituted upon request. When supplied with a special lubricant, the package marking will have a suffix code after the bearing number for internal factory identification.

Alignment:

In any full complement type needle bearing, good alignment is a necessity for obtaining optimum bearing life.

Good alignment provides uniform distribution of the load over the entire length of the bearing.

In the event good alignment is not economically or mechanically practical for a housing-mounted bearing, the NBE and NBK series bearings should be considered because of their ability to self-align within $\pm 5^\circ$.

Military qualification:

Aircraft bearings from McGill meet the requirements of U.S. Military Specification MIL-B-3990 and the following U.S. Military Standards:

Bearing Series	Military Standard
NBC	MS-24461
NBE	MS-24463
NBK	MS-24464
NBF	MS-24465
NBL	MS-24466
AFC	MS-21438
AL	MS-21439
HRS	MS-21432
CHRS	MS-21447

Nomenclature:

Part numbers for the NBC, NBE, NBK, NBL, AFC and AL bearing series are derived as follows:

Example: 4 NBC612ZP

BEARING BORE IN 1/16THS	BEARING TYPE	WIDTH IN 1/16THS	OUTER DIAMETER IN 1/16THS	RELUBRICATION	PLATING
4	NBC	6	12	Z	P
4	NBE	6	15	Z	P
16	NBK	20	36	YZ	P
12	NBF	16	28	Y	J
8	NBL	20	22	Y	J
6	AFC	8	17	Y*	J*
14	AL	32	34	Y*	J*

Y = Annular lubrication groove in bore and oil holes in inner ring

Z = Annular lubrication groove on O.D. and holes in outer ring

P = Exposed surfaces cadmium plated as mounted

J = Outer diameter and outer diameter corners chrome plated and other exposed surfaces as mounted cadmium plated

Y* = Features present but not coded in this series

J* = Features present but not coded in this series

Mounting:

End plates which are fastened to the bearing as an aid to handling and installation should be firmly backed up by washers or other clamping surfaces which are flat and square with shaft centerline.

To provide sufficient support for the endplates, the clamping surfaces should have a minimum diameter as specified in column "Clamping Diameter." Care should be taken that endwise pressure on the endplate does not cause reduction in endwise clearance and possible binding of the bearings.

For coding and load rating information, refer to page 102. NBF and NBL series bearings are only for replacement in older applications. For current applications and future designs, use AFC and AL series bearings.

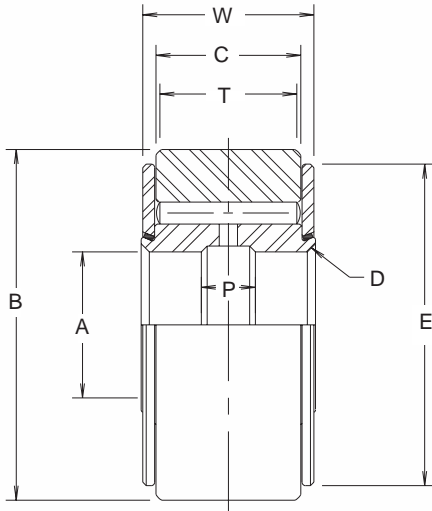

NBF

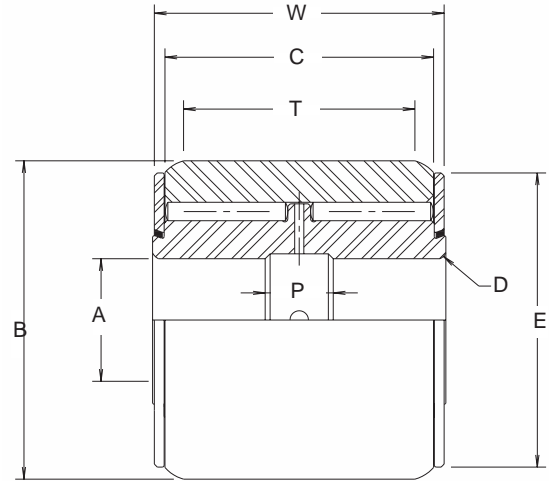

NBL

ABMA NUMBER	MILITARY STANDARD REFERENCE NUMBER MS-	A BORE		B		W OVER-ALL WIDTH +.000 -0.005	C O.R. WIDTH +.000 -.005	D RADIUS OR 45° BEVEL	E END RING DIA.	P I.R. GROOVE WIDTH	T MIN. TRACK CONTACT WIDTH	TRACK CAPACITY 180,000 PSI STEEL	BEARING RATING		SHAFT DIAMETER				MIN. CLAMPING DIA.	APPROX. WEIGHT LBS.
		+.0000 -0.0007	O.D.	TOL.	*AS A TRACK ROLLER								LIMIT LOAD	PUSH FIT		PRESS FIT				
														MAX.	TOL.	MAX.	TOL.			
3NBF512YJ	24465-3	.1900	.7500			.312	.218	.022	11/16	3/32	1/8	290	900	1200	.1894		.1902		7/16	.029
4NBF614YJ	24465-4	.2500	.8750			.375	.281	.022	3/4	1/8	7/32	575	1430	1910	.2494		.2502		33/64	.049
6NBF817YJ	24465-6	.3750	1.0625			.500	.375	.022	15/16	3/16	5/16	1000	2700	3600	.3744		.3752		43/64	.098
8NBF1012YJ	24465-8	.5000	1.3125			.625	.500	.032	1 3/16	3/16	7/16	1785	4300	5780	.4994	+.0000 -0.0005	.5002	+.0000 -0.0005	27/32	.178
10NBF1224YJ	24465-10	.6250	1.5000			.750	.625	.032	1 3/8	1/4	9/16	2600	6400	8530	.6244		.6252		61/64	.266
12NBF1628YJ	24465-12	.7500	1.7500			1.000	.875	.032	1 5/8	1/4	3/4	4050	10700	14200	.7494		.7502		1 7/64	.495
14NBF1832YJ	24465-14	.8750	2.0000	+.0000		1.125	1.000	.032	1 7/8	1/4	7/8	5350	13700	18300	.8744		.8752		1 7/32	.713
20NBF2040YJ	24465-20	1.2500	2.5000	-.0010		1.250	1.049	.032	1 29/32	3/8	15/16	7370	18900	25200	1.2494		1.2503		1 5/8	1.060
24NBF2448YJ	24465-24	1.5000	3.0000			1.500	1.299	.032	2 7/8	3/8	1 11/64	10800	28800	38400	1.4994	+.0000 -0.0006	1.5003	+.0000 -0.0006	1 63/64	2.070
28NBF2455YJ	24465-28	1.7500	3.4375			1.500	1.299	.032	3 5/16	3/8	1 11/64	12400	33500	44400	1.7494		1.7503		2 9/32	2.710
32NBF2462YJ	24465-32	2.0000	3.8750			1.500	1.299	.032	3 3/4	3/8	1 11/64	13900	37100	49300	1.9994		2.0003		2 9/16	3.420
36NBF2469YJ	24465-36	2.2500	4.3125			1.500	1.299	.032	4 3/16	3/8	1 11/64	15500	41800	55600	2.2494	+.0000 -0.0007	2.2503	+.0000 -0.0007	2 55/64	4.230
40NBF2476YJ	24465-40	2.5000	4.7500			1.500	1.299	.032	4 5/8	3/8	1 11/64	17100	45500	60400	2.4994		2.5003		3 7/64	5.140
44NBF2480YJ	24465-44	2.7500	5.0000			1.500	1.299	.032	4 7/8	3/8	1 11/64	18000	49200	65800	2.7494		2.7503		3 11/32	5.490
6NBL1618YJ	24466-6	.3750	1.1250			1.000	.875	.022	1	3/16	3/4	2600	5370	7160	.3744		.3752		43/64	.228
8NBL2022YJ	24466-8	.5000	1.3750			1.250	1.125	.032	1 1/4	1/4	1	4250	9370	12500	.4994		.5002		57/64	.416
10NBL2426YJ	24466-10	.6250	1.6250			1.500	1.375	.032	1 1/2	3/8	1 1/8	5650	15000	20000	.6244	+.0000 -0.0005	.6252	+.0000 -0.0005	1 7/64	.693
12NBL2830YJ	24466-12	.7500	1.8750			1.750	1.625	.032	1 3/4	3/8	1 3/8	7950	21400	28500	.7494		.7502		1 9/32	1.080
14NBL3234YJ	24466-14	.8750	2.1250	+.0000		2.000	1.875	.032	2	3/8	1 5/8	10650	28900	38500	.8744		.8752		1 15/32	1.550
16NBL3638YJ	24466-16	1.0000	2.3750	-.0010		2.250	2.049	.032	2 1/8	3/8	1 51/64	13200	33600	44900	.9994		1.0002		1 37/64	2.150
20NBL4044YJ	24466-20	1.2500	2.7500			2.500	2.299	.032	2 1/2	3/8	2 3/64	17300	44700	59600	1.2494		1.2502		1 27/32	3.090
24NBL4448YJ	24466-24	1.5000	3.0000			2.750	2.549	.032	2 3/4	3/8	2 19/64	21200	53600	71600	1.4994	+.0000 -0.0006	1.5002	+.0000 -0.0006	1 63/64	3.820
28NBL4855YJ	24466-28	1.7500	3.4375			3.000	2.799	.032	3 3/16	3/8	2 35/64	27000	69000	92000	1.7494		1.7502		2 9/32	5.400
32NBL4826YJ	24466-32	2.0000	3.8750			3.000	2.799	.032	3 5/8	3/8	2 35/64	30400	76600	102000	1.9994	+.0000 -0.0007	2.0002	+.0000 -0.0007	2 9/16	6.800

Some individual sizes not available from stock. Consult McGill Customer Service for availability.
 * This is capacity as a track roller.

AFC & AL SERIES

AFC and AL series bearings, for track roller applications, were developed from, and are interchangeable dimensionally with NBF and NBL series bearings. They have heavy section outer rings and offer several advantages over NBF and NBL series bearings. LUBRI-DISC® seals provide integral sealing, reduced operating friction and longer relubrication intervals. They are molded, molybdenum disulfide-filled, type 6/6 nylon material. Contact sealing in the outer ring counterbore and on the end plate O.D. helps keep grease in and contaminants out. LUBRI-DISC® seals also eliminate metal on metal sliding contact, reducing friction and operating temperatures, and extend grease lubricant life. The ring portion also acts as a back-up seal. Outer ring counterbore construction provides a wider outer ring with increased effective track contact width. AFC series outer ring O.D.'s are crowned and AL series outer rings have large, blended corners to reduce edge stresses. Surface plating is the same as for NBF and NBL series bearings. End plates must be properly backed by machined boss faces on a clevis or washers, as they are not intended to support thrust loads.

Both types can be relubricated through the inner ring bore. They are supplied with grease prepack per customer requirement when so stated. Otherwise, they will be supplied with grease per MIL-G-23827. Minimum and maximum continuous operating temperatures limited by LUBRI-DISC® seal material to -65°F. to +250°F.

For coding and load rating information, refer to page 102.

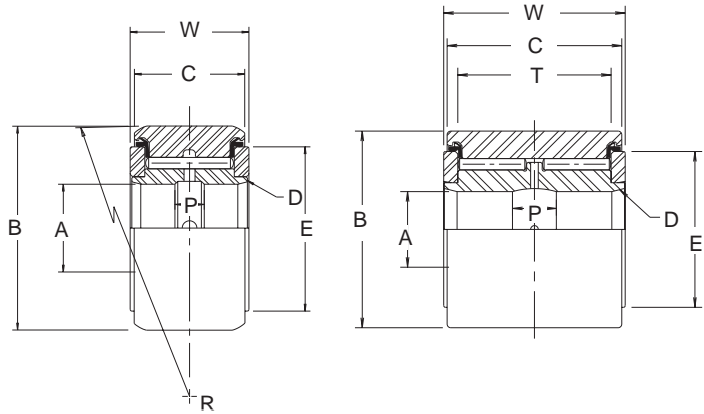

AFC

AL

BEARING NUMBER	MILITARY STANDARD REFERENCE NUMBER MS-	BORE DIA.		W	C	D	R	E	P	T	TRACK CAPACITY 180,000 PSI STEEL	BEARING RATING		SHAFT DIAMETER				MIN. CLAMPING DIA.	APPROX. WEIGHT LBS.
		+.0000	-.0007									PUSH FIT	LIMIT LOAD	PRESS FIT					
		±.001	±.001	MAX.	TOL.	MAX.	TOL.												
3AFC512	21438-103	.1900	.7500	.312	.280	.022	10	19/32	3/32	-	290	900	1200	.1894		.1902		7/16	.027
4AFC614	21438-104	.2500	.8750	.375	.345	.022	10	11/16	1/8	-	575	1430	1910	.2494		.2502		33/64	.047
6AFC817	21438-106	.3750	1.0625	.500	.455	.022	10	55/64	3/16	-	1000	2700	3600	.3744		.3752		43/64	.088
8AFC1021	21438-108	.5000	1.3125	.625	.580	.032	12 1/2	1 1/16	3/16	-	1785	4300	5700	.4994	+.0005	.5002	+.0005	27/32	.171
10AFC1224	21438-110	.6250	1.5000	.750	.705	.032	17 1/2	1 3/16	1/4	-	2600	6400	8500	.6244		.6252		61/64	.262
12AFC1628	21438-112	.7500	1.7500	1.000	.950	.032	25	1 13/32	1/4	-	4050	10700	14200	.7494		.7502		1 7/64	.493
14AFC1832	21438-114	.8750	2.0000	1.125	1.075	.032	27 1/2	1 1/2	1/4	-	5350	14400	19300	.8744		.8752		1 7/32	.695
20AFC2040	21438-120	1.2500	2.5000	1.250	1.200	.032	30	2 1/64	3/8	-	7100	18900	25300	1.2494		1.2503		1 5/8	1.060
24AFC2448	21438-124	1.5000	3.0000	1.500	1.440	.032	60	2 29/64	3/8	-	10900	28400	37900	1.4994	+.0000	1.5003	+.0000	2	2.070
28AFC2455	21438-128	1.7500	3.4375	1.500	1.440	.032	60	2 25/32	3/8	-	12400	33000	44100	1.7494	-.0006	1.7502	-.0006	2 9/32	2.710
†32AFC2462	21438-132	2.0000	3.8750	1.500	1.440	.032	60	3 1/8	3/8	-	14000	36700	48900	1.9994		2.0002		2 9/16	3.420
†36AFC2469	21438-136	2.2500	4.3125	1.500	1.440	.032	60	-	3/8	-	15600	41200	55000	2.2494	+.0000	2.2502	+.0000	2 55/64	4.230
†40AFC2476	21438-140	2.5000	4.7500	1.500	1.440	.032	60	3 51/64	3/8	-	17200	44900	59900	2.4994	-.0007	2.5002	-.0007	3 7/64	5.140
†44AFC2480	21438-144	2.7500	5.0000	1.500	1.440	.032	60	4 1/16	3/8	-	18100	48600	64800	2.7494		2.7502		3 11/32	5.490
4AL1214	-	.2500	.875	.750	.720	.022	-	43/64	3/16	.560	1550	2310	3080	.2494		.2502		37/64	.100
6AL1618	21439-106	.3750	1.1250	1.000	.940	.022	-	55/64	3/16	.750	2600	5370	7130	.3744		.3752		43/64	.206
8AL2022	21439-108	.5000	1.3750	1.250	1.190	.032	-	1 5/64	1/4	1.000	4250	9370	12500	.4994		.5002		57/64	.416
10AL2426	21439-110	.6250	1.6250	1.500	1.440	.032	-	1 19/64	3/8	1.125	5650	15000	19900	.6244	+.0000	.6252	+.0000	1 7/64	.693
12AL2830	21439-112	.7500	1.8750	1.750	1.690	.032	-	1 1/2	3/8	1.375	7950	21400	28500	.7494	-.0005	.7502	-.0005	1 9/32	1.080
14AL3234	21439-114	.8750	2.1250	2.000	1.940	.032	-	1 21/32	3/8	1.625	10650	28900	38500	.8744		.8752		1 15/32	1.550
16AL3638	21439-116	1.0000	2.3750	2.250	2.190	.032	-	1 55/64	3/8	1.797	13200	33600	44900	.9994		1.0002		1 37/64	2.150
†20AL4044	21439-120	1.2500	2.7500	2.500	2.440	.032	-	2 13/64	3/8	2.047	17300	44600	59500	1.2494		1.2502		1 27/32	3.090
†24AL4448	21439-124	1.5000	3.0000	2.750	2.690	.032	-	2 29/64	3/8	2.297	21200	53600	71300	1.4994	+.0000	1.5002	+.0000	1 63/64	3.820
†28AL4855	21439-128	1.7500	3.4375	3.000	2.940	.032	-	2 53/64	3/8	2.547	27000	69000	92000	1.7494	-.0006	1.7502	-.0006	2 9/32	5.400
†32AL4862	21439-132	2.0000	3.8750	3.000	2.940	.032	-	3 7/32	3/8	2.547	30400	76600	102000	1.9994	+.0000	2.0002	+.0000	2 9/16	6.800

* This is capacity as a track roller.
 † Not available from stock, consult factory for availability.

NBE and NBK series bearings are self-aligning, housing outer race-supported needle bearings. They are self-aligned by a spherical outer race O.D. mating in a spherical adapter bore and relubricated both through the bore of the inner race and the O.D. of the outer race. External surfaces except bore are cadmium[®] plated. Outer race surfaces are black oxide finished and bearings are packed with MIL-G-23827 grease unless otherwise specified. Races and rollers are 52100 bearing quality steel and end plates are hardened spring steel. End plates are retained by a swedged ring that holds the bearing together prior to application assembly.

Inner race holes and grooves are omitted from the -3, -4 and -5 sizes because of bolt strength limitations. The shaft and housing fit dimensions shown below are for steel housings only. Decrease dimension .0002" for aluminum alloy housings.

NBK series is basically the same as the NBE series except for an integral rib on the O.D. of the inner race and two rows of full complement needle rollers.

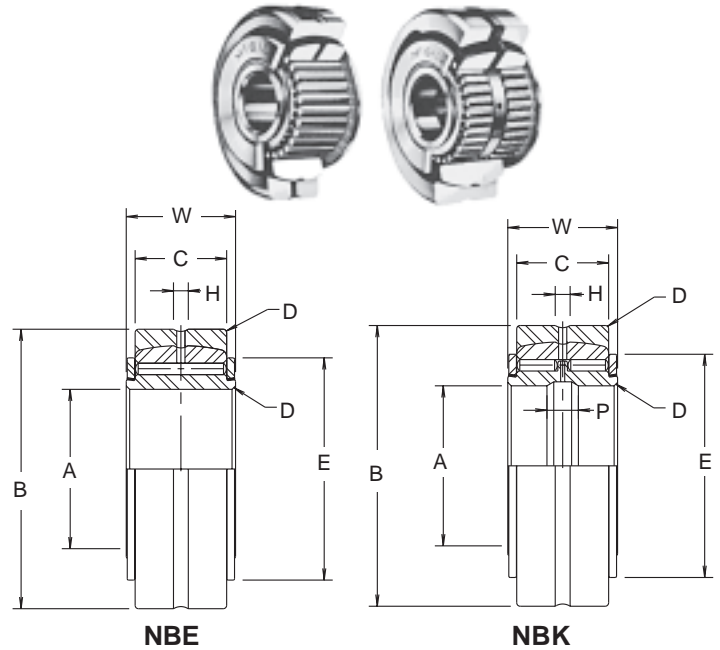

ABMA NUMBER	MILITARY STANDARD REFERENCE NUMBER MS-	A		B		W	C	D	E	H	P
		BORE		O.D.		OVERALL WIDTH	O.R. WIDTH	RADIUS OR 45° BEVEL	END RING DIA.	O.R. GROOVE WIDTH	I.R. GROOVE WIDTH
		IN.	TOL.	IN.	TOL.	+0.000 -0.005	+0.000 -0.005				
3NBE514ZP	24463-3	.1900	+0.000 -0.007	.8750	+0.000 -0.005	.312	.218	.022	5/8	1/16	-
4NBE615ZP	24463-4	.2500		.9375		.375	.281	.022	11/16	3/32	-
5NBE717ZP	24463-5	.3125		1.0625		.437	.344	.022	3/4	3/32	-
6NBK919YZP	24464-6	.3750		1.1875		.562	.469	.022	13/16	1/8	3/16
7NBK1021YZP	24464-7	.4375		1.3125		.625	.531	.032	7/8	1/8	3/16
8NBK1224YZP	24464-8	.5000		1.5000		.750	.656	.032	1 1/32	1/8	3/16
9NBK1427YZP	24464-9	.5625		1.6875		.875	.781	.032	1 3/32	5/32	3/16
10NBK1628YZP	24464-10	.6250		1.7500		1.000	.906	.032	1 5/32	5/32	1/4
12NBK1830YZP	24464-12	.7500		1.8750		1.125	1.000	.032	1 9/32	5/32	1/4
14NBK2034YZP	24464-14	.8750		2.1250		1.250	1.125	.032	1 1/2	5/32	3/8
16NBK2036YZP	24464-16	1.0000		2.2500		1.250	1.125	.032	1 5/8	5/32	3/8
20NBK2040YZP	24464-20	1.2500		2.5000		1.250	1.049	.032	1 29/32	5/32	3/8
24NBK2044YZP	24464-24	1.5000		2.7500		1.250	1.049	.032	2 5/32	5/32	3/8
32NBK2052YZP	24464-32	2.0000		3.2500		1.250	1.049	.032	2 21/32	5/32	3/8
40NBK2060YZP	24464-40	2.5000		3.7500		1.250	1.049	.032	3 5/32	5/32	3/8
48NBK2068YZP	24464-48	3.0000		4.2500		1.250	1.049	.032	3 21/32	5/32	3/8
56NBK2078YZP	24464-56	3.5000	+0.000 -0.008	4.8750	+0.000 -0.010	1.250	1.049	.044	4 7/32	5/32	3/8

ABMA NUMBER	MILITARY STANDARD REFERENCE NUMBER MS-	* AIRCRAFT STATIC CAPACITY	SHAFT DIAMETER				HOUSING BORE				MIN. CLAMPING DIA.	APPROX. WEIGHT LBS.
			SLIP FIT		PRESS FIT		PRESS FIT		SLIP FIT			
			MAX.	TOL.	MAX.	TOL.	MIN.	TOL.	MIN.	TOL.		
3NBE514ZP	24463-3	2700	.1894	.1902	+0.000 -0.005	.8742	+0.005 -0.000	.8749	+0.005 -0.000	7/16	.041	
4NBE615ZP	24463-4	4300	.2494	.2502		.9367		.9374		33/64	.053	
5NBE717ZP	24463-5	6100	.3119	.3127		1.0617		1.0624		37/64	.079	
6NBK919YZP	24464-6	6800	.3744	.3752		1.1867		1.1874		41/64	.130	
7NBK1021YZP	24464-7	8800	.4369	.4377		1.3116		1.3124		45/64	.174	
8NBK1224YZP	24464-8	13000	.4994	.5002		1.4991		1.4999		27/32	.293	
9NBK1427YZP	24464-9	17700	.5619	.5627		1.6866		1.6874		57/64	.420	
10NBK1628YZP	24464-10	23200	.6244	.6252		1.7491		1.7499		61/64	.520	
12NBK1830YZP	24464-12	30000	.7494	.7502		1.8741		1.8749		1 5/64	.630	
14NBK2034YZP	24464-14	38700	.8744	.8752		2.1238		2.1249		1 1/4	.870	
16NBK2036YZP	24464-16	43000	.9994	1.0002		2.2488		2.2499		1 3/8	.960	
20NBK2040YZP	24464-20	47100	1.2494	1.2503		2.4988		2.4999		1 5/8	1.070	
24NBK2044YZP	24464-24	54900	1.4994	1.5003		2.7488		2.7499		1 7/8	1.230	
32NBK2052YZP	24464-32	70600	1.9994	2.0003		3.2485		3.2498		2 3/8	1.490	
40NBK2060YZP	24464-40	86200	2.4994	2.5003		3.7485		3.7498		2 7/8	1.780	
48NBK2068YZP	24464-48	101900	2.9994	3.0003		4.2485		4.2498		3 3/8	2.060	
56NBK2078YZP	24464-56	120200	3.4994	3.5004	4.8735	4.8748	3 31/32	2.650				

* Aircraft Static Capacity is the Ultimate Static Load Rating.
 ® Cadmium plating to be replaced by zinc-nickel plating at a later date.

Aircraft Bearings

NBC SERIES

NBC aircraft needle bearings are self-contained, outer race housing supported bearings having a full complement of spherical end rollers. External surfaces except bore are cadmium[®] plated. Bearings are packed with MIL-G 23827 grease unless otherwise specified. Races and rollers are 52100 bearing quality steel and end plates are hardened spring steel. End plates are retained by a swaged ring holding the bearing together prior to application assembly. This series is ordinarily supplied with lubrication grooves and holes in both inner and outer races.

Inner race holes and grooves are omitted from the -3, -4 and -5 sizes because of bolt strength limitations. The shaft and housing fit dimensions shown are for steel housings only. Decrease dimension .0002" for aluminum alloy housings.

For coding and load rating information, refer to page 102.

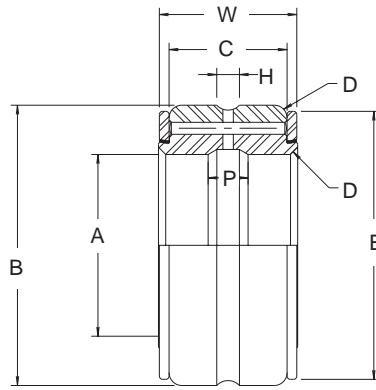

ABMA NUMBER	MILITARY STANDARD REFERENCE NUMBER MS-	A		B		W	C	D	E	H	P
		BORE		O.D.		OVERALL WIDTH	O.R. WIDTH	RADIUS OR 45° BEVEL	END RING DIA.	O.R. GROOVE WIDTH	I.R. GROOVE WIDTH
		NOM. DIA.	TOL.	NOM. DIA.	TOL.	+ .000 - .005	+ .000 - .005				
3NBC511ZP	24461-3	.1900	+ .0000 - .0007	.6875	+ .0000 - .0005	.312	.218	.022	5/8	1/16	-
4NBC612ZP	24461-4	.2500		.7500		.375	.281	.022	11/16	3/32	-
5NBC713ZP	24461-5	.3125		.8125		.437	.344	.022	3/4	3/32	-
6NBC914YZP	24461-6	.3750		.8750		.562	.469	.022	13/16	1/8	3/16
7NBC1015YZP	24461-7	.4375		.9375		.625	.531	.032	7/8	1/8	3/16
8NBC1218YZP	24461-8	.5000		1.1250		.750	.656	.032	1 1/32	1/8	3/16
9NBC1419YZP	24461-9	.5625		1.1875		.875	.781	.032	1 3/32	5/32	3/16
10NBC1620YZP	24461-10	.6250		1.2500		1.000	.906	.032	1 5/32	5/32	1/4
12NBC1822YZP	24461-12	.7500		1.3750		1.125	1.000	.032	1 9/32	5/32	1/4
14NBC2026YZP	24461-14	.8750		1.6250		1.250	1.125	.032	1 1/2	5/32	3/8
16NBC2028YZP	24461-16	1.0000		1.7500		1.250	1.125	.032	1 5/8	5/32	3/8
20NBC2032YZP	24461-20	1.2500		2.0000		1.250	1.049	.032	1 29/32	5/32	3/8
24NBC2036YZP	24461-24	1.5000		2.2500		1.250	1.049	.032	2 5/32	5/32	3/8
28NBC2040YZP	24461-28	1.7500		2.5000		1.250	1.049	.032	2 13/32	5/32	3/8
32NBC2044YZP	24461-32	2.0000		2.7500		1.250	1.049	.032	2 21/32	5/32	3/8
36NBC2048YZP	24461-36	2.2500		3.0000		1.250	1.049	.032	2 29/32	5/32	3/8
40NBC2052YZP	24461-40	2.5000	3.2500	1.250	1.049	.032	3 5/32	5/32	3/8		
44NBC2056YZP	24461-44	2.7500	3.5000	1.250	1.049	.032	3 13/32	5/32	3/8		
48NBC2060YZP	24461-48	3.0000	3.7500	1.250	1.049	.032	3 21/32	5/32	3/8		
52NBC2064YZP	24461-52	3.2500	4.0000	1.250	1.049	.032	3 29/32	5/32	3/8		
56NBC2070YZP	24461-56	3.5000	4.3750	1.250	1.049	.044	4 7/32	5/32	3/8		
60NBC2074YZP	24461-60	3.7500	4.6250	1.250	1.049	.044	4 15/32	5/32	3/8		
64NBC2078YZP	24461-64	4.0000	4.8750	1.250	1.049	.044	4 23/32	5/32	3/8		

ABMA NUMBER	MILITARY STANDARD REFERENCE NUMBER MS-	* AIRCRAFT STATIC CAPACITY	SHAFT DIAMETER				HOUSING BORE				MIN. CLAMPING DIA.	APPROX. WEIGHT LBS.
			SLIP FIT		PRESS FIT		PRESS FIT		SLIP FIT			
			MAX.	TOL.	MAX.	TOL.	MIN.	TOL.	MIN.	TOL.		
3NBC511ZP	24461-3	2700	.1894	+ .0000 - .0005	.1902	+ .0000 - .0005	.6867	+ .0005 - .0000	.6874	+ .0005 - .0000	7/16	.028
4NBC612ZP	24461-4	4300	.2494		.2502		.7492		.7499			
5NBC713ZP	24461-5	6100	.3119		.3127		.8117		.8124			
6NBC914YZP	24461-6	9500	.3744		.3752		.8742		.8749			
7NBC1015YZP	24461-7	12000	.4369		.4377		.9367		.9374			
8NBC1218YZP	24461-8	17400	.4994		.5002		1.1242		1.1249			
9NBC1419YZP	24461-9	22500	.5619		.5627		1.1867		1.1874			
10NBC1620YZP	24461-10	28300	.6244		.6252		1.2492		1.2499			
12NBC1822YZP	24461-12	35800	.7494		.7502		1.3741		1.3749			
14NBC2026YZP	24461-14	45800	.8744		.8752		1.6241		1.6249			
16NBC2028YZP	24461-16	50900	.9994		1.0002		1.7491		1.7499			
20NBC2032YZP	24461-20	56800	1.2494		1.2503		1.9990		1.9999			
24NBC2036YZP	24461-24	66300	1.4994		1.5003		2.2488		2.2499			
28NBC2040YZP	24461-28	75700	1.7494		1.7503		2.4988		2.4999			
32NBC2044YZP	24461-32	85200	1.9994		2.0003		2.7488		2.7499			
36NBC2048YZP	24461-36	94600	2.2494		2.2503		2.9988		2.9999			
40NBC2052YZP	24461-40	104100	2.4994	2.5003	3.2485	3.2498						
44NBC2056YZP	24461-44	113500	2.7494	2.7503	3.4985	3.4998						
48NBC2060YZP	24461-48	123000	2.9994	3.0003	3.7485	3.7498						
52NBC2064YZP	24461-52	132500	3.2494	3.2504	3.9985	3.9998						
56NBC2070YZP	24461-56	145100	3.4994	3.5004	4.3735	4.3748						
60NBC2074YZP	24461-60	154500	3.7494	3.7504	4.6235	4.6248						
64NBC2078YZP	24461-64	164000	3.9994	4.0004	4.8735	4.8748						

* Aircraft Static Capacity is the Ultimate Static Load Rating. Not all sizes available from stock. Consult McGill Customer Service for availability.

® Cadmium plating to be replaced by zinc-nickel plating at a later date.

McGill manufactures integral stud type airframe bearings in accordance with MS21432, MS21447 and NAS-562 standards, as well as special modifications. Consult McGill Customer Service for availability.

General engineering data

The integral stud type airframe track roller for cantilever mounting should be applied only after the following design features are considered:

1. The limit load listed in the tabular material is for rolling elements only; therefore, stud strength must be considered for actual maximum load carrying design limits.
2. Track capacity may supersede bearing fatigue capacity.
3. Threads on all bearings listed in tabular material conform to MIL-S-8879 for Class UNJF-3A.
4. Proper housing support is imperative for optimum performance. Studs must be supported uniformly with mounting holes square with boss faces. Junction of boss face and mounting hole should be kept as sharp as possible without burrs.
5. Bearings packed with MIL-G-23827 grease unless otherwise specified.

The coding of the HRS and CHRS will be as follows:

Basic Type	Size	Plating	Relub.	Cotter Pin Hole Requirement	Grip Lgth. Seals in 1/16ths
------------	------	---------	--------	-----------------------------	-----------------------------

HRS — Standard bearing with stud heat treated to 36-44 Rockwell "C" scale.

CHRS — Standard bearing with stud heat treated to 36-44 Rockwell "C" scale and crowned roller O.D.

C — Exposed surfaces of the outer race chrome plated .0004" min. The remaining exposed surfaces cadmium plated.

T — Lubricator installed in threaded end of stud and cotter pin hole will be eliminated.

K — Stud slotted to receive an NAS 460 washer.

F — Lubricator installed in flange end of stud.

A — No cotter pin hole in threaded end of stud.

R — Sealed bearing.

P — Exposed surfaces of outer race cadmium plated. Remaining exposed surfaces of end plate, flange and stud also cadmium plated.

Example: HRS4 CT8 — Bearing type "HRS" indicates heat treated stud, "4" indicates a .375 stud diameter, .875 O.D., and .469 outer width, "C" indicates chrome plated outer, "T" indicates lubricator in threaded end of stud and cotter pin hole omitted, "8" indicates a grip length of 8/16" or 1/2".



Double sealed bearings are available in the HRS or CHRS series. To specify, add letter "R" to catalog number. Example: HRS1CFAR8.

RELUBRICATION FROM FLANGE END

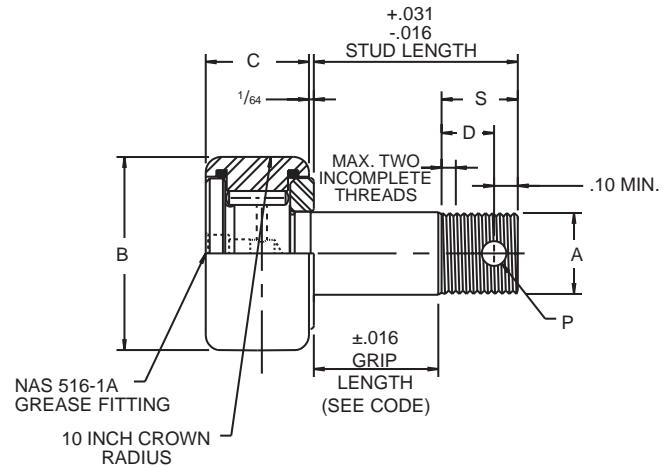

RELUBRICATION FROM THREADED END

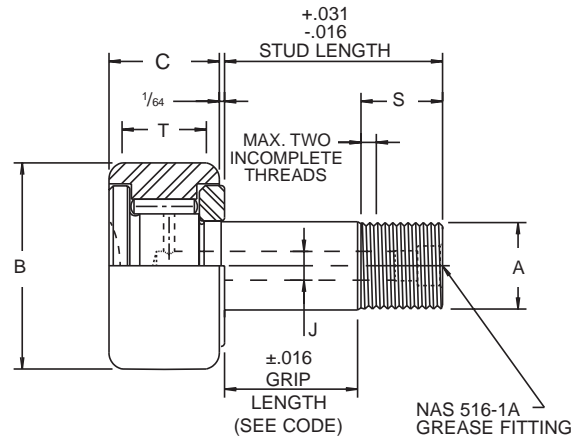

McGILL NUMBER		MILITARY STANDARD NUMBER		NAS 562 NUMBER	A	B	C	D	S	THREAD SIZE	P	T	J	TRACK CAPACITY 180,000 PSI STEEL	BEARING RATING		HOUSING BORE DIA. FOR STUD	
CYLINDRICAL O.D.	CROWNED O.D.	CYLINDRICAL O.D.	CROWNED O.D.	CYLINDRICAL O.D.	STUD DIA.	ROLLER O.D.	ROLLER WIDTH	(MIN.)	THREAD LENGTH (REF.)	3	COTTER PIN HOLE DIA.	TRACK CONTACT LENGTH (MIN.)	DIA. (REF.)		2	4	1	MAX.
HRS1	CHRS1	MS21432-3	MS21447-3	NAS562-3	.190	.5000	.281	.211	.344	10-32	.070	.230	none	385	395	790	.1905	.1900
HRS2	CHRS2	MS21432-4	MS21447-4	NAS562-4	.250	.6875	.281	.224	.344	1/4-28	.076	.230	.076	525	470	940	.2505	.2500
HRS3	CHRS3	MS21432-5	MS21447-5	NAS562-5	.312	.7500	.344	.234	.359	5/16-24	.076	.290	.076	725	830	1660	.3125	.3120
HRS4	CHRS4	MS21432-6	MS21447-6	NAS562-6	.375	.8750	.469	.265	.359	3/8-24	.106	.380	.106	1100	1360	2720	.3755	.3750
HRS5	CHRS5	MS21432-7	MS21447-7	NAS562-7	.437	1.0000	.531	.283	.422	7/16-20	.106	.430	.106	1425	1930	3860	.4375	.4370
HRS6	CHRS6	MS21432-8	MS21447-8	NAS562-8	.500	1.1250	.656	.314	.422	1/2-20	.106	.530	.106	1975	3040	6080	.5005	.5000

* Limit load is two-thirds of aircraft static capacity.

AIRCRAFT BEARINGS

INTERCHANGEABILITY CHART



MILITARY STANDARD NUMBER	* TORRINGTON®	McGILL
24461-3	3NBC511ZP	3NBC511ZP
24461-4	4NBC612ZP	4NBC612ZP
24461-5	5NBC713ZP	5NBC713ZP
24461-6	6NBC914YZP	6NBC914YZP
24461-7	7NBC1015YZP	7NBC1015YZP
24461-8	8NBC1218YZP	8NBC1218YZP
24461-9	9NBC1419YZP	9NBC1419YZP
24461-10	10NBC1620YZP	10NBC1620YZP
24461-12	12NBC1822YZP	12NBC1822YZP
24461-14	14NBC2026YZP	14NBC2026YZP
24461-16	16NBC2028YZP	16NBC2028YZP
24461-20	20NBC2032YZP	20NBC2032YZP
24461-24	24NBC2036YZP	24NBC2036YZP
24461-28	28NBC2040YZP	28NBC2040YZP
24461-32	32NBC2044YZP	32NBC2044YZP
24461-36	36NBC2048YZP	36NBC2048YZP
24461-40	40NBC2052YZP	40NBC2052YZP
24461-44	44NBC2056YZP	44NBC2056YZP
24461-48	48NBC2060YZP	48NBC2060YZP
24461-52	52NBC2064YZP	52NBC2064YZP
24461-56	56NBC2070YZP	56NBC2070YZP
24461-60	60NBC2074YZP	60NBC2074YZP
24461-64	64NBC2078YZP	64NBC2078YZP
24465-3	3NBF512YJ	3NBF512YJ
24465-4	4NBF614YJ	4NBF614YJ
24465-6	6NBF817YJ	6NBF817YJ
24465-8	8NBF1021YJ	8NBF1021YJ
24465-10	10NBF1224YJ	10NBF1224YJ
24465-12	12NBF1628YJ	12NBF1628YJ
24465-14	14NBF1832YJ	14NBF1832YJ
24465-20	20NBF2040YJ	20NBF2040YJ
24465-24	24NBF2448YJ	24NBF2448YJ
24465-28	28NBF2455YJ	28NBF2455YJ
24465-32	32NBF2462YJ	32NBF2462YJ
24465-36	36NBF2469YJ	36NBF2469YJ
21438-103	ATF-3	3AFC512
21438-104	ATF-4	4AFC614
21438-106	ATF-6	6AFC817
21438-108	ATF-8	8AFC1021
21438-110	ATF-10	10AFC1224
21438-112	ATF-12	12AFC1628
21438-114	ATF-14	14AFC1832
21438-120	ATF-20	20AFC2040
21438-124	ATF-24	24AFC2448
21438-128	ATF-28	28AFC2455
21438-132	ATF-32	32AFC2462
21438-136	ATF-36	36AFC2469
21438-140	ATF-40	40AFC2476
21438-144	ATF-44	44AFC2480

MILITARY STANDARD NUMBER	* TORRINGTON®	McGILL
24465-40	40NBF2476YJ	40NBF2476YJ
24465-44	44NBF2480YJ	44NBF2480YJ
24466-6	6NBL1618YJ	6NBL1618YJ
24466-8	8NBL2022YJ	8NBL2022YJ
24466-10	10NBL2426YJ	10NBL2426YJ
24466-12	12NBL2830YJ	12NBL2830YJ
24466-14	14NBL3234YJ	14NBL3234YJ
24466-16	16NBL3638YJ	16NBL3638YJ
24466-20	20NBL4044YJ	20NBL4044YJ
24466-24	24NBL4448YJ	24NBL4448YJ
24466-28	28NBL4855YJ	28NBL4855YJ
24466-32	32NBL4862YJ	32NBL4862YJ
24463-3	3NBE514ZP	3NBE514ZP
24463-4	4NBE615ZP	4NBE615ZP
24463-5	5NBE717ZP	5NBE717ZP
24464-6	6NBK919YZP	6NBK919YZP
24464-7	7NBK1021YZP	7NBK1021YZP
24464-8	8NBK1224YZP	8NBK1224YZP
24464-9	9NBK1427YZP	9NBK1427YZP
24464-10	10NBK1628YZP	10NBK1628YZP
24464-12	12NBK1830YZP	12NBK1830YZP
24464-14	14NBK2034YZP	14NBK2034YZP
24464-16	16NBK2036YZP	16NBK2036YZP
24464-20	20NBK2040YZP	20NBK2040YZP
24464-24	24NBK2044YZP	24NBK2044YZP
24464-32	32NBK2052YZP	32NBK2052YZP
24464-40	40NBK2060YZP	40NBK2060YZP
24464-48	48NBK2068YZP	48NBK2068YZP
24464-56	56NBK2078YZP	56NBK2078YZP
	HRS-1C	HRS-1C
	HRS-2C	HRS-2C
	HRS-3C	HRS-3C
	HRS-4C	HRS-4C
	HRS-5C	HRS-5C
	HRS-6C	HRS-6C
N/A	AE55879	4AL1214
21439-106	ATL-6	6AL1618
21439-108	ATL-8	8AL2022
21439-110	ATL-10	10AL2426
21439-112	ATL-12	12AL2830
21439-114	ATL-14	14AL3234
21439-116	ATL-16	16AL3638
21439-120	ATL-20	20AL4044
21439-124	ATL-24	24AL4448
21439-128	ATL-28	28AL4855
21439-132	ATL-32	32AL4862
21447-3	HRSC-1C	CHRS-1C
21447-4	HRSC-2C	CHRS-2C
21447-5	HRSC-3C	CHRS-3C
21447-6	HRSC-4C	CHRS-4C
21447-7	HRSC-5C	CHRS-5C
21447-8	HRSC-6C	CHRS-6C

* The trademark TORRINGTON is a registered trademark of The Torrington Company.

Back-rest rollers

BEARING NUMBER	OUTSIDE DIA. (RD) ±.0005	STUD DIA. (SD)		ROLLER WIDTH (W)		STUD LENGTH (SL)
			TOL. +.0000		TOL. +.000	
SK-1103	.625	.2512	-.0003	.2910	-.001	21/64
SK-1104	.875	.3140	-.0005	.3050	-.002	29/64
SK-1106	1.375	.5645		.4500		37/64
SK-1107	1.500	.5645		.5645		41/64
SK-1108	1.750	.5645		.5645		49/64

These sizes are normally available from stock.

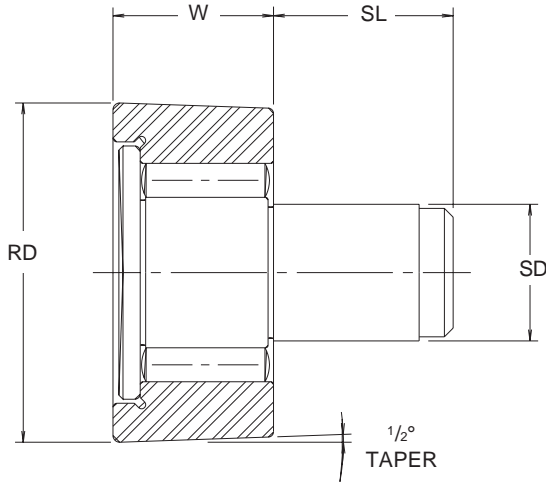

Band saw guide wheel

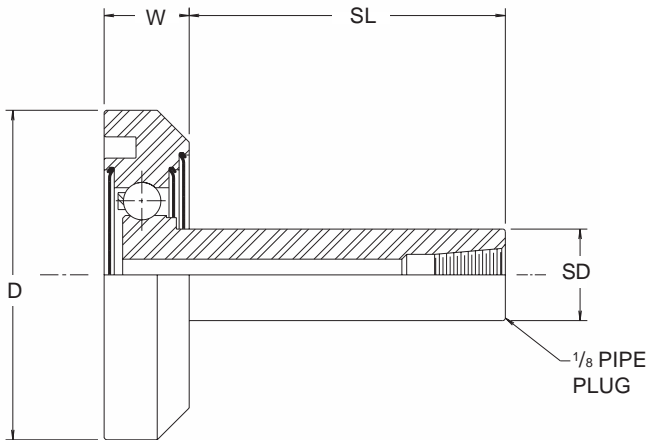

BEARING NUMBER	OUTSIDE DIA. (D)	STUD DIA. (SD) +.000 -.001	ROLLER WIDTH (W)	STUD LENGTH (SL)
0 SAW GUIDE	1 15/16	.750	1/2	1 3/4
1 SAW GUIDE	2 13/16	.750	19/32	2 11/64

Available from stock.

FEATURES**Special bearings from McGill**

Standard bearings from McGill fill the requirements of numerous applications because of their construction, available features, load and speed capabilities; however, there are times that they do not meet the needs set forth by some customers. In some instances, modification to a standard product can resolve the design problem. In others, entirely special bearings are needed for specific quality, size, life or load carrying requirements. McGill engineers have provided this type of service for more than fifty years.

The spectrum of the special bearings from McGill can vary from individual rolling elements and commercial bearings, to ball or roller bearings for the aircraft industry.

Application considerations for specials sometimes need closer scrutiny than for standards or modifications. Obviously knowing the speed, loads, temperature, lubricant, and application environment are a must, but it is necessary to sometimes analyze the complete application, bearing design or components more closely.

Special bearings for each type of McGill product line are common, as well as of lift truck ball and roller bearings, ball bearing cam followers, flat thrust ball and roller bearings, precision needle, roller, ball bearings, and aircraft type products. To name a few, a variety of examples can be found in this catalog to demonstrate some of the different designs. Designs on this page - and similar types - available by special order only. Consult McGill Engineering Department for details.

Modifications to the standard product could include but not be limited to the following:

- Stem/Thread Length - Longer/Shorter/No Threads
- Lubrication Features - Special Fittings/Eliminated/Plugged/Tapped Holes
- Lubricants-High-Low Temperature (Lubrication grease codes used instead of dash no.)
- Corner/OD. Contours-Special Size/Crowned Radius Concave
- Special Geometrics - Runouts/Taper/Size Control/Special Adapters
- Coatings/Platings - Dry film/Thin Dense Chrome/Thick Dense Chrome/Gov't. Chrome/Zinc-Nickel/Cadmium/Silver
- Materials - Corrosion Resistant/Carburized/Tool Steels/Through Hardened
- Heat Treatment - Hardness/Salt Bath Nitriding/Double Heat Treat
- Seals - Temperature/Chemical Environment/Contamination

Modified standard products and special made to order (MTO'S) bearings, could encompass many features.

Contact the McGill Engineering Department for assistance with your special application.

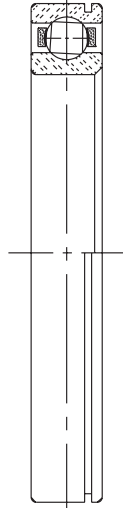

Special precision ball bearing from McGill, developed to meet requirements of a stationary field magnetic clutch. The narrow and thin section bearing of comparatively large bore diameter is built to tolerances to accurately position and align all moving parts in relation to the stationary coil. Radial fit is controlled to provide accuracy of magnetic flux air gaps. Retainer is non-magnetic. This bearing facilitates rapid and smooth response of the clutch even when operating at high cyclic rates.

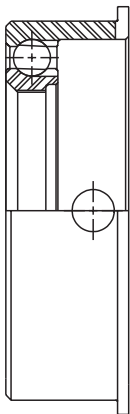
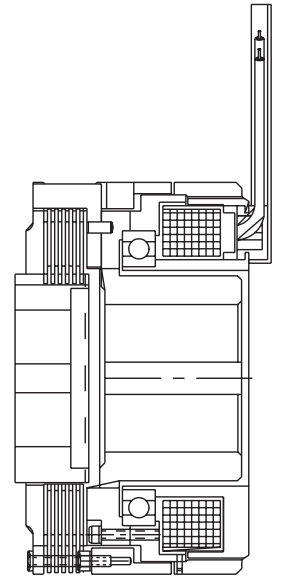
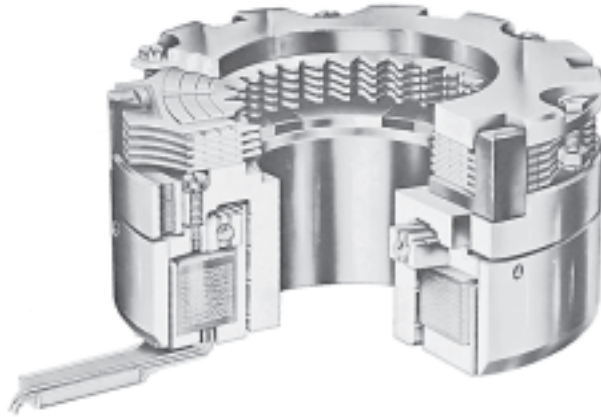

Full complement radial ball bearing for piston pump pintle application.

BALL BEARINGS

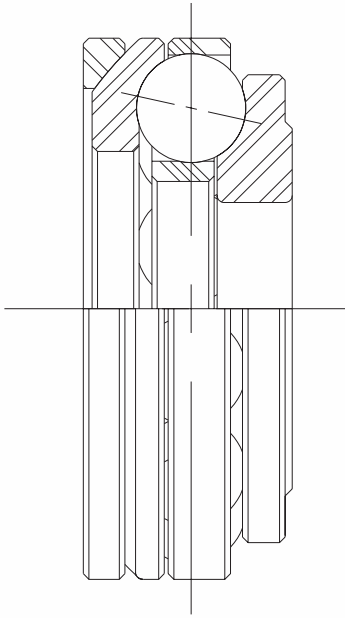

Flat thrust angular contact ball bearing for hydraulic pump.

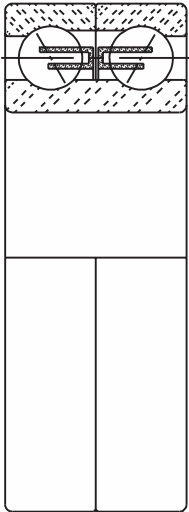

Double row outer race ball bearing for machine tool spindle.

With and without stud

Special CAMROL® type bearings improve performance and provide an additional safety factor for greater reliability in this accounting machine application. The integral stud and roller units were built to design requirements. These bearings are located on the card feed cam follower arms and they operate a pressure plate on the sensing unit of this high speed card feed.

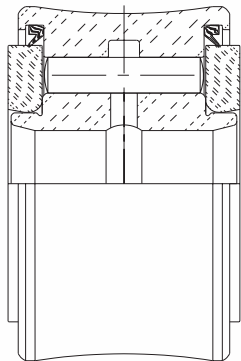
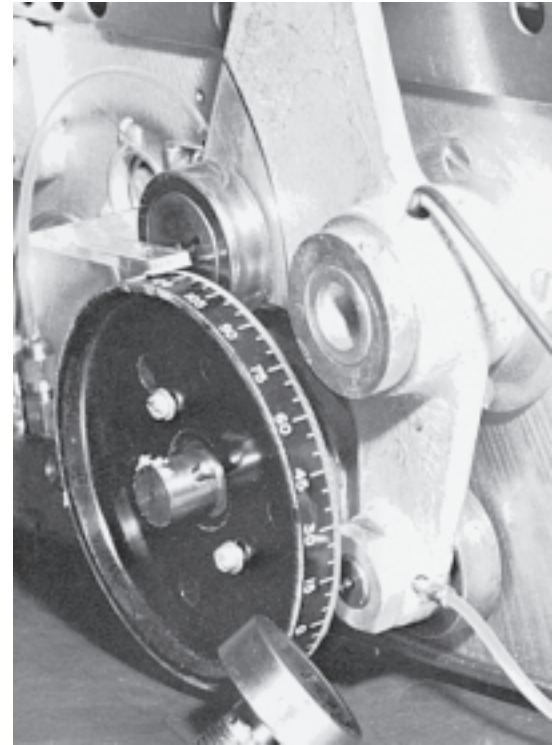
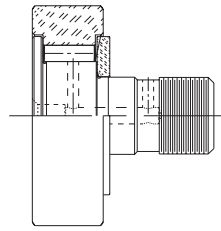

Concave or radius CYR-S bearing as guide and support bearing for hydraulic cylinder.

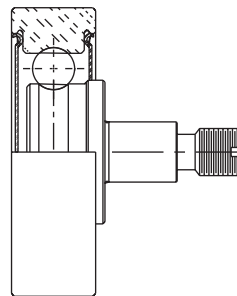

Ball bearing cam follower used as lower feed roll bearing on print press.

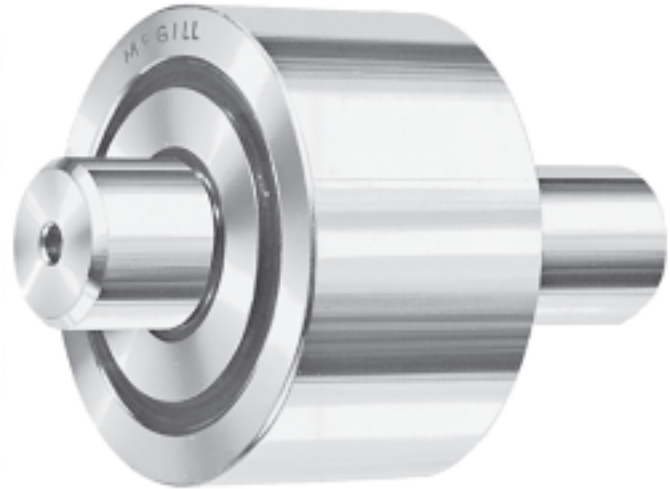
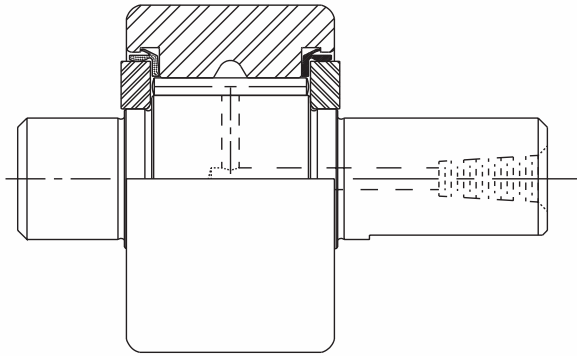

Double sealed double ended stud cam follower as guide and support roller on scarfing machine.

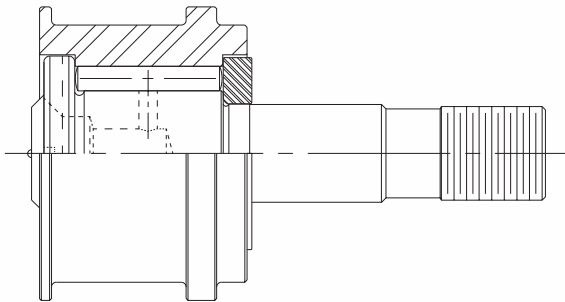

Roller bearing cam follower with recessed outer race for back-up roller on lathe.

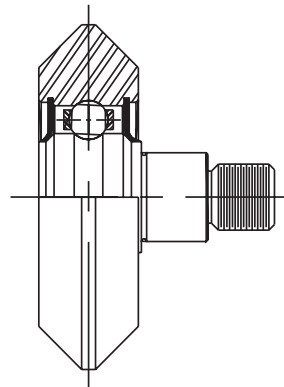

Sealed ball bearing cam follower with angular or guiding surfaces for punch press tool station actuation.

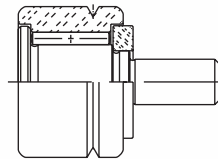

Special cam follower with grooved outer race for wire straightening applications.

Four of these specially designed turntable rollers support the entire weight of the superstructure plus overhanging work load. They replaced inadequate plain friction rollers on cranes and shovels to allow for smoother handling of even greater imposed loads, with less track wear. Simplified lubrication and longer life reduced maintenance.

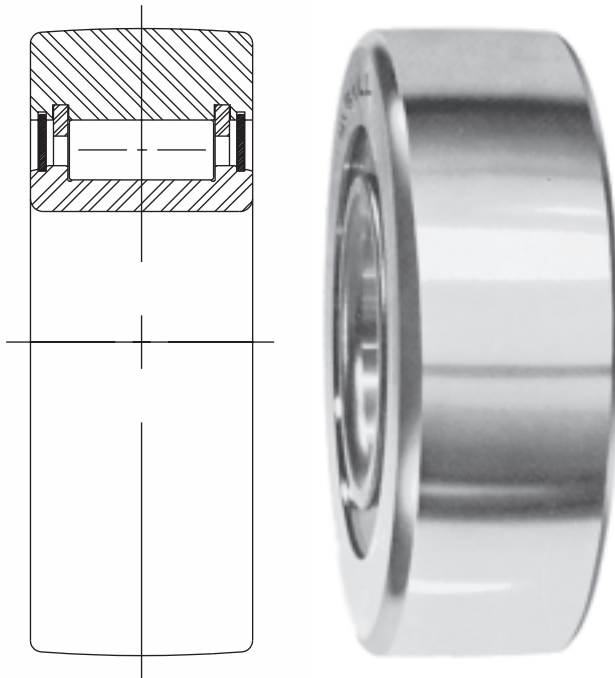
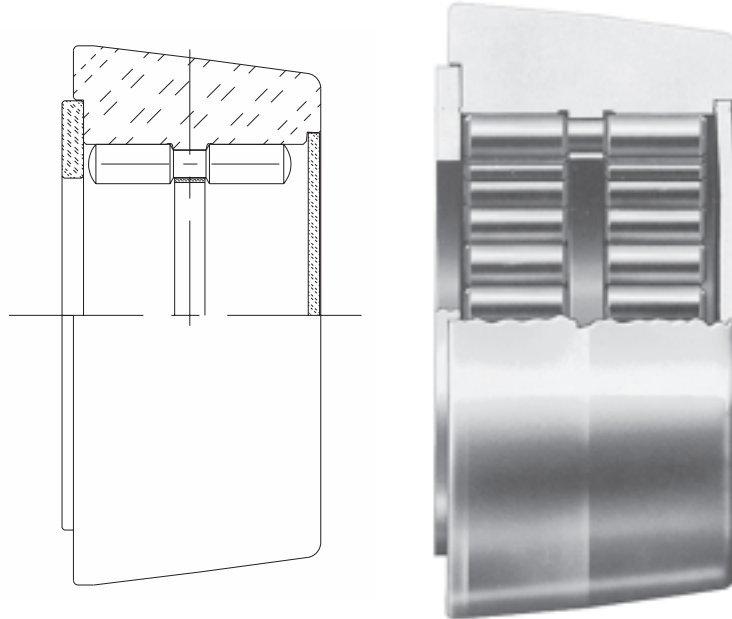

Cylindrical roller bearing for lift-truck mast roller.

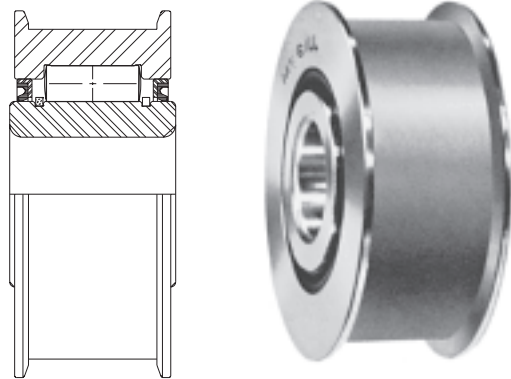

Recessed O.D. Cylindrical roller bearing for lift-truck cross head chain guide roller.

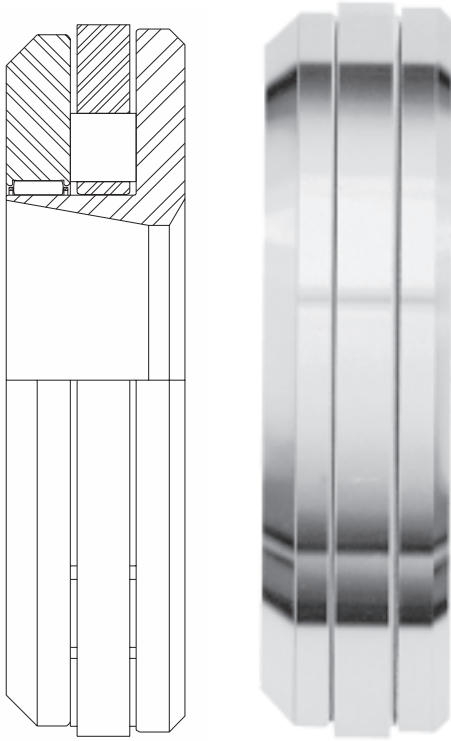

Combined flat thrust and radial roller bearing for hydrostatic transmission.

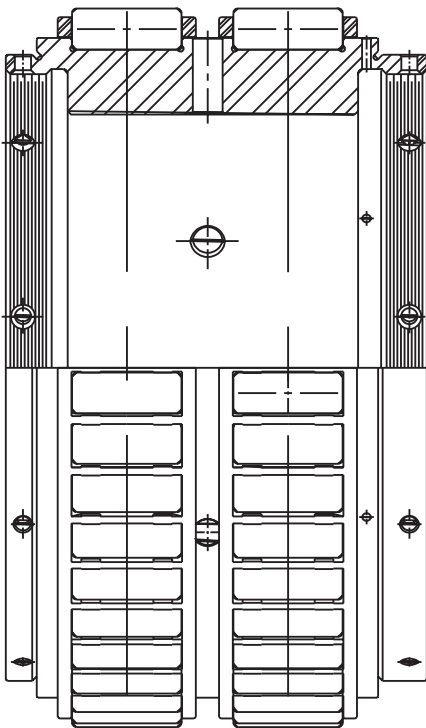

Double row cylindrical roller bearing with threaded inner for helicopter planet pinion bearing.

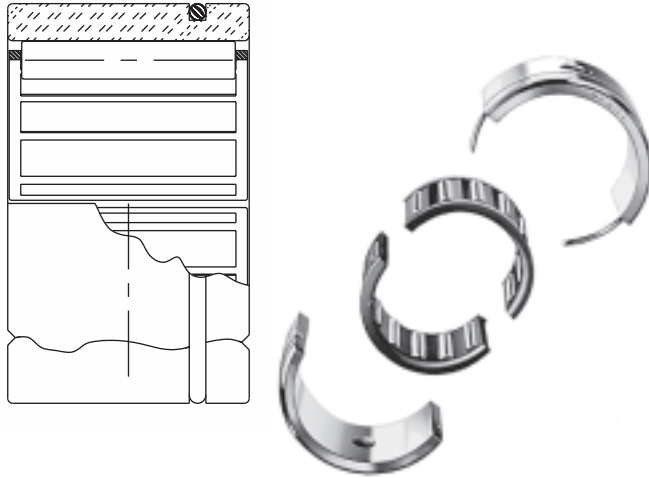

Split needle roller bearing assembly with sleeve for out-board motor center main bearing.

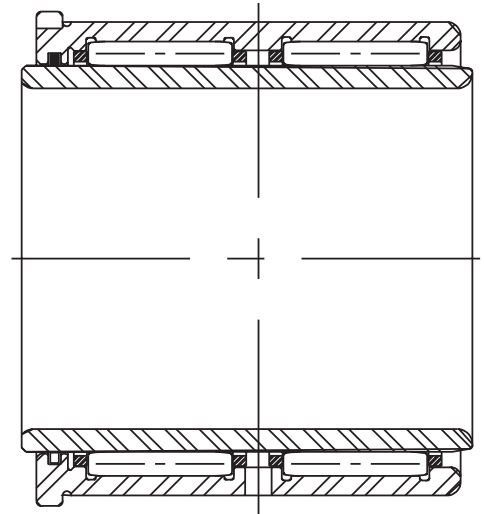

Double row caged thin section needle bearing used as spindle bearing in automatic screw machines.

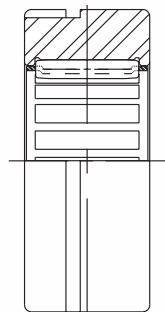

Cage type needle bearing for hydraulic gear pump.

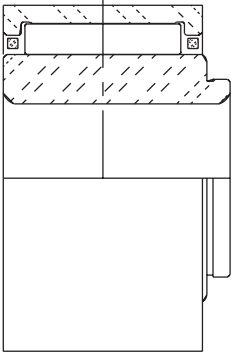

Needle bearing with square O.D. for actuator bearing on radial piston type pump.

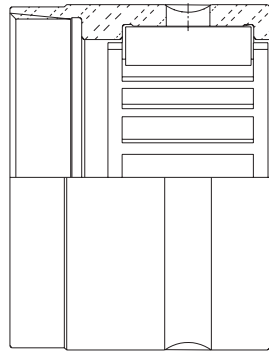

Single sealed cage type needle upper main bearing for outboard motor.

Self-aligning bushing

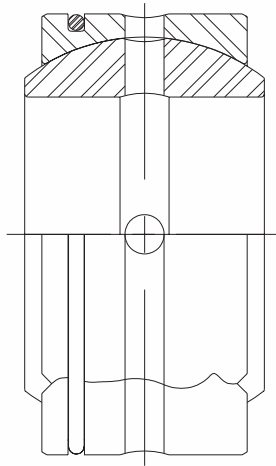

YOUR NAME AND TITLE Date

COMPANY NAME ADDRESS

APPLICATION: Currently in use New

If currently in use, what bearings are now being used?

Manufacturer Part No.

Equipment bearings to be used on: Model No.

No. bearings per unit Anticipated requirement per year

OPERATING TEMPERATURE Speeds

LOADS Desired L-10 Life

(Magnitude & Direction)

Intermittent (Describe) Shock

SHAFT:

Horizontal Angular Oscillating (Angle) Vertical

Rotating Stationary Potential shaft deflection or housing deflection

Degree of expected misalignment Housing material

Shaft material Shaft heat treat (Inner race omitted)

LUBRICATION:

Type Method Cycle

If CF type, are all oil holes needed? Yes No Lubricant used or required

FOR GEAR PUMP CALCULATIONS, the following additional information is needed:

Operating pressure in PSI RPM

No. of teeth Gear Pitch Gear Width

Percentage or time of duty at operating pressure — Test Basis

Percentage or time of duty at operating pressure — Field Basis

FOR GEAR TRAINS, the additional information is needed in addition to a print:

Horsepower input Distance between gears Helix angle

Input speed Pitch diameters Spiral angle No. of teeth

IF SPIRAL OR HELICAL GEARING:

Direction of driving pinion Hand of Spiral or Helix

REMARKS: Use space below for sketch

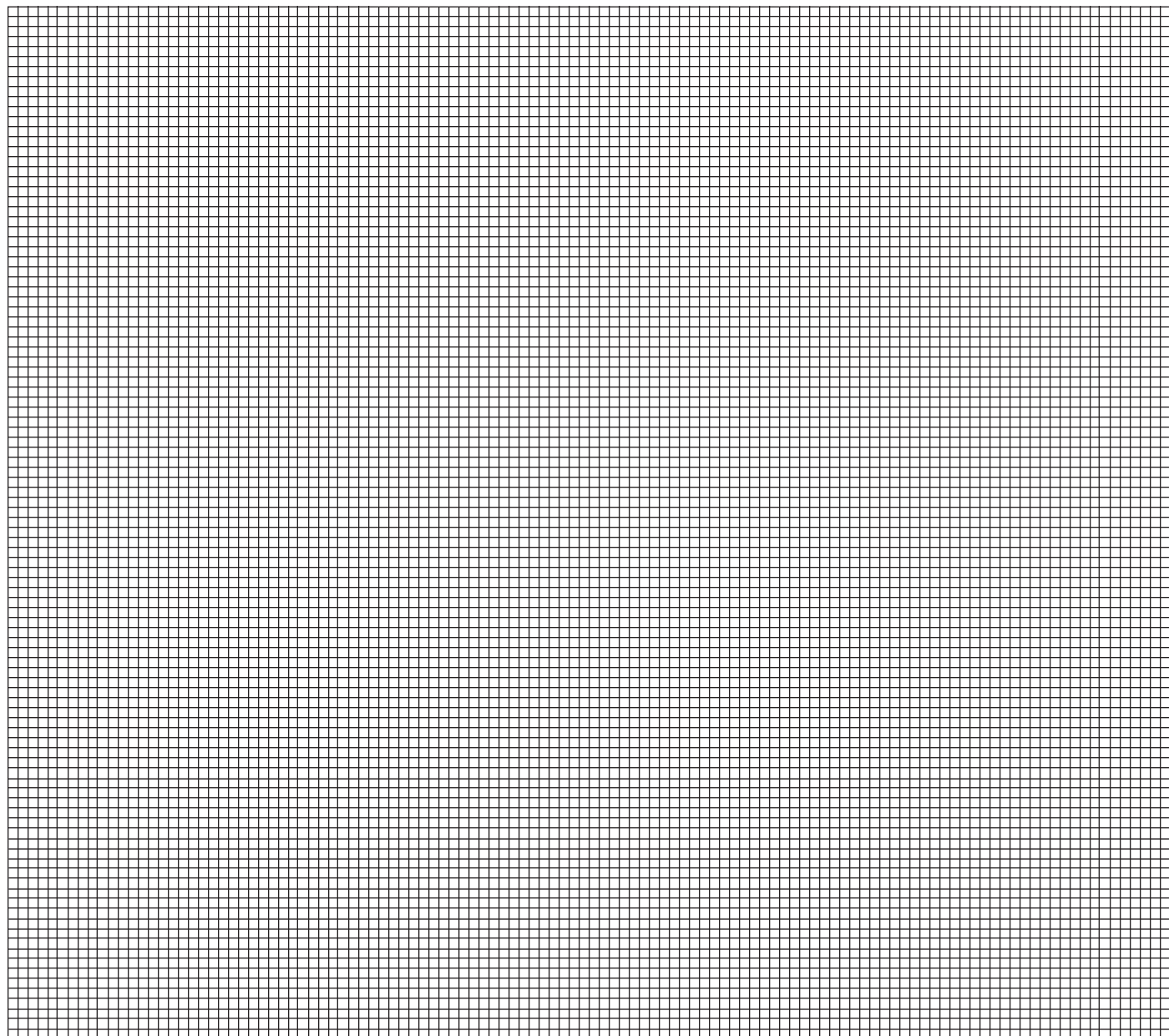

Have You Attached Drawings?

McGILL MANUFACTURING CO., INC.
Bearing Division
Valparaiso, Indiana

BEARING APPLICATION DATA

YOUR NAME AND TITLE Date

COMPANY NAME ADDRESS

APPLICATION: Currently in use New

If currently in use, what bearings are now being used?

Manufacturer Part No.

Equipment bearings to be used on: Model No.

No. bearings per unit Anticipated requirement per year

OPERATING TEMPERATURE Speeds.....

LOADS Desired L-10 Life.....

(Magnitude & Direction)

Intermittent (Describe) Shock

SHAFT:

Horizontal Angular Oscillating (Angle)Vertical

Rotating..... Stationary Potential shaft deflection or housing deflection

Degree of expected misalignment Housing material

Shaft material Shaft heat treat (Inner race omitted)

LUBRICATION:

Type Method Cycle

If CF type, are all oil holes needed? Yes No Lubricant used or required

FOR GEAR PUMP CALCULATIONS, the following additional information is needed:

Operating pressure in PSI RPM.....

No. of teeth Gear Pitch Gear Width

Percentage or time of duty at operating pressure — Test Basis

Percentage or time of duty at operating pressure — Field Basis

FOR GEAR TRAINS, the additional information is needed in addition to a print:

Horsepower input Distance between gears Helix angle

Input speed Pitch diameters Spiral angle No. of teeth

IF SPIRAL OR HELICAL GEARING:

Direction of driving pinion Hand of Spiral or Helix.....

REMARKS: Use space below for sketch

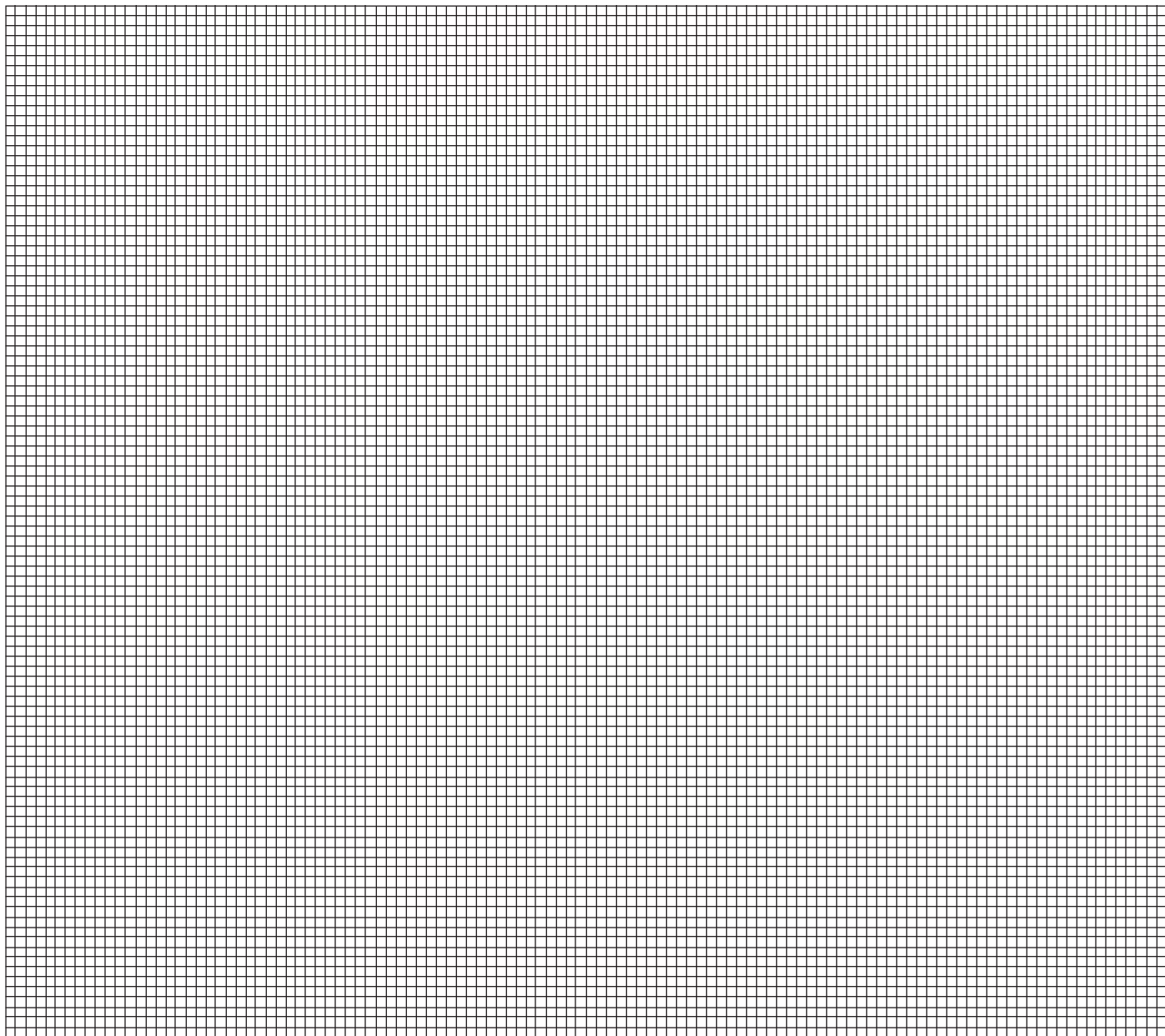

Have You Attached Drawings?

McGILL MANUFACTURING CO., INC.

Bearing Division
Valparaiso, Indiana

YOUR NAME AND TITLE Date

COMPANY NAME ADDRESS

APPLICATION: Currently in use New

If currently in use, what bearings are now being used?

Manufacturer Part No.

Equipment bearings to be used on: Model No.

No. bearings per unit Anticipated requirement per year

OPERATING TEMPERATURE Speeds

LOADS Desired L-10 Life

(Magnitude & Direction)

Intermittent (Describe) Shock

SHAFT:

Horizontal Angular Oscillating (Angle)Vertical

Rotating Stationary Potential shaft deflection or housing deflection

Degree of expected misalignment Housing material

Shaft material Shaft heat treat (Inner race omitted)

LUBRICATION:

Type Method Cycle

If CF type, are all oil holes needed? Yes No Lubricant used or required

FOR GEAR PUMP CALCULATIONS, the following additional information is needed:

Operating pressure in PSI RPM

No. of teeth Gear Pitch Gear Width

Percentage or time of duty at operating pressure — Test Basis

Percentage or time of duty at operating pressure — Field Basis

FOR GEAR TRAINS, the additional information is needed in addition to a print:

Horsepower input Distance between gears Helix angle

Input speed Pitch diameters Spiral angle No. of teeth

IF SPIRAL OR HELICAL GEARING:

Direction of driving pinion Hand of Spiral or Helix

REMARKS: Use space below for sketch

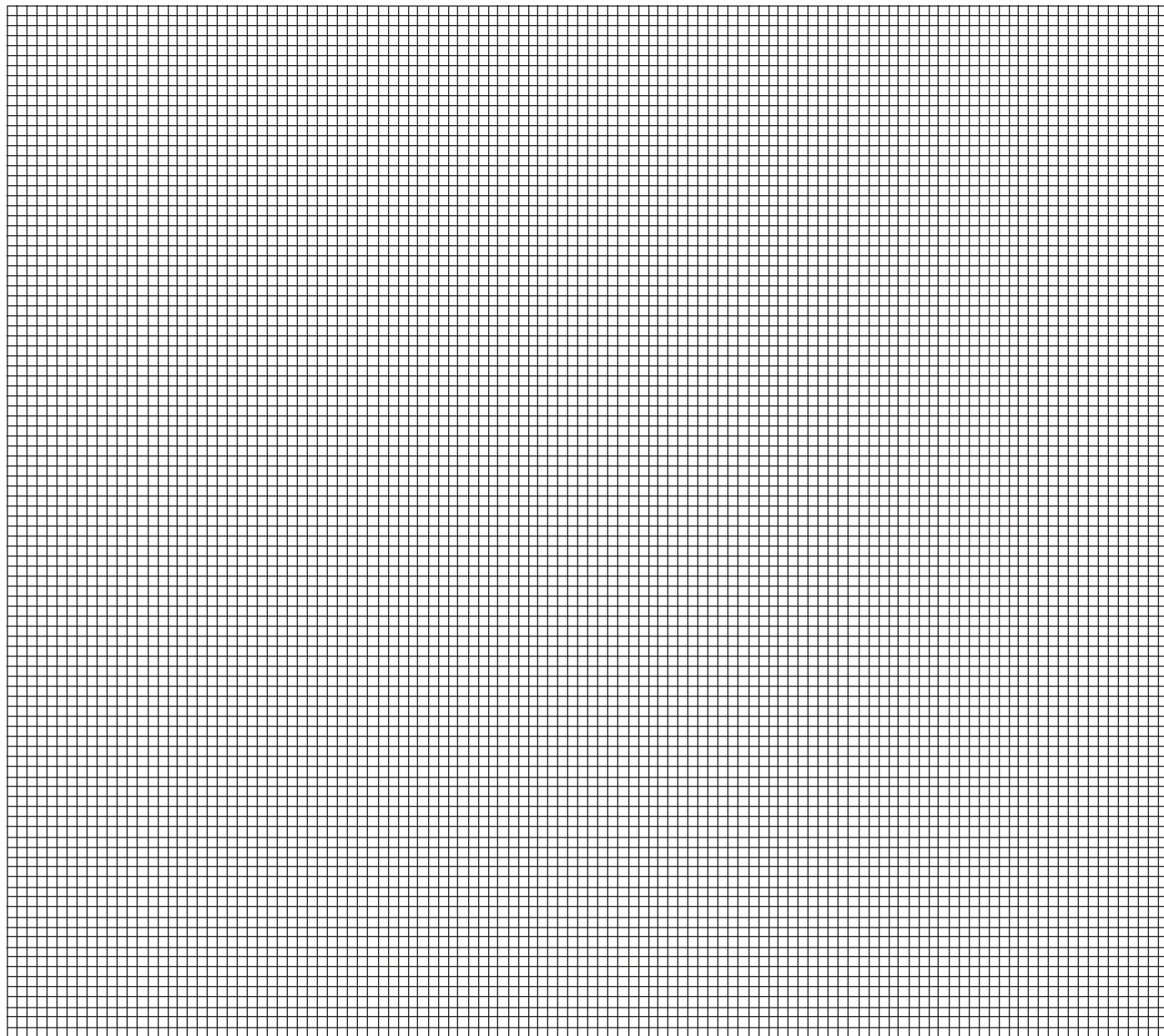

Have You Attached Drawings?

McGILL MANUFACTURING CO., INC.

Bearing Division
Valparaiso, Indiana

BEARING PERFORMANCE STARTS WITH PROPER STATEMENT OF REQUIREMENTS

In order to apply anti-friction bearings successfully, certain types of information must be made available to the bearing engineer. Very often, problems which are encountered in testing or in the field could have been avoided through a

more detailed analysis of the application requirements before the bearing was selected. Proper definition of the problem also eliminates the need for annoying correspondence and delays caused by insufficient basic information.

The following is a guide for the proper compilation of information needed.

- (1) Application description
- (2) Temperatures
 - (A) Ambient
 - (B) Expected operating
 - (C) Heat source
- (3) Rotation conditions
 - (A) Speed of rotation
 - (B) Speed of oscillation
 - (C) Angle of oscillation
 - (D) Static conditions
 - (E) Shaft or housing
- (4) Mounting conditions
 - (A) Horizontal
 - (B) Vertical
 - (C) Angular
- (5) Bearing load
 - (A) Magnitude
 - (B) Direction
 - (C) Intermittent loading — describe
 - (D) Vibratory loads
 - (E) Shock loads
- (6) Life requirements
 - (A) Minimum life (L_{10})
 - (B) Average life (L_{50})
 - (C) Operating cycle—intermittent life requirements
- (7) Lubrication
 - (A) Type lubricant
 - (B) Method (system)
 - (C) Cycle (frequency)
 - (D) FDA approval
- (8) Amount of expected misalignment
- (9) Potential shaft deflection or housing deflection, if known
- (10) Sealing
 - (A) Type of seal required
 - (B) Direction of sealing — control of contamination or retention of lubricant
 - (C) Amount and type of contamination present, if known
 - (D) Seal drag permitted

- (11) Limiting bearing dimensions
 - (A) Limiting shaft size
 - (B) Limiting housing bore
 - (C) Limiting width
 - (D) Shaft and housing fillet radii
- (12) Shaft
 - (A) Material used
 - (B) Inner race required?
 - (C) Shaft heat treatment (where inner races are omitted)
 - (D) Shaft surface finish (inner race omitted)
- (13) Housing description
 - (A) Housing material
 - (B) Housing bore surface finish

In many cases, it is advantageous to have more specific application data for applications involving gear pumps as well as other types of hydraulic pumps and transmission applications. This information will be as follows:

- (1) Gear pumps
 - (A) Operating pressure is PSI
 - (B) Number of teeth in gear
 - (C) Gear pitch diameter
 - (D) Gear width
- (2) Other hydraulic pumps
 - (A) Piston diameters
 - (B) Length of piston stroke
 - (C) Piston angle with relation to shaft center line
 - (D) Number of pistons or cylinders
 - (E) Vane width for vane type pumps
 - (F) Maximum vane area
- (3) Transmission applications
 - (A) Input horsepower
 - (B) Distance between gears
 - (C) Input speeds
 - (D) Gear pitch diameter
 - (E) Number of gear teeth
 - (F) For spiral or helical gearing
 - 1 direction of driving pinion
 - 2 direction of spiral or helix
 - 3 helix angle
 - 4 spiral angle

EPT EDGE™

The Integrated Solution!

Not only select products, but also view the Media Library and create CAD Template Drawings.

Emerson Power Transmission customers are demanding software functionality that will provide them with an easier, faster, and more accurate process to select our products. EPT EDGE™ is designed to provide those customers with “Product Selection, Media Library, and CAD Template drawings”.

Use the product selection modules to accurately configure our products to meet your application specific needs. It's a three step process--

- 1) Enter your application specific criteria,
- 2) Review a list of alternatives that will all meet your criteria,
- 3) Select the desired product that best meets your application's needs.

Once you have selected a product, view catalog information in the Media Library which provides a user friendly interface to navigate around EPT's wide range of products.

EPT EDGE™ also provides our users with the capability to create scaled CAD drawings. CAD drawings are created from application specific criteria and then placed directly into the user's AutoCAD® drawing.

- Cost Savings- EPT EDGE™ can cut drive costs 30% and more vs. typical manually selected products.
- Time Savings- EPT EDGE™ selects the best products available within seconds, not minutes or hours.
- Confidence- EPT EDGE™ meets all specs within prescribed service factors. You reduce both the risk of underspecifying and the high cost of overspecifying.

AutoCAD® is a registered trademark of Autodesk, Inc., which is not affiliated with Emerson Power Transmission Corp.



EPT EDGE™



Fax Request To: (606) 564-2239

Browning® **HOP-FLEX**® **McGILL**® **Morse**™ **ROLLWAY**® **SEALMASTER**® **Van Gorp**®

APPLICATION CONSIDERATIONS

The proper selection and application of power transmission products and components, including the related area of product safety, is the responsibility of the customer. Operating and performance requirements and potential associated issues will vary appreciably depending upon the use and application of such products and components. The scope of the technical and application information included in this publication is necessarily limited. Unusual operating environments and conditions, lubrication requirements, loading supports, and other factors can materially affect the application and operating results of the products and components and the customer should carefully review its requirements. Any technical advice or review furnished by Emerson Power Transmission Corporation

and its divisions with respect to the use of products and components is given in good faith and without charge, and Emerson assumes no obligation or liability for the advice given, or results obtained, all such advice and review being given and accepted at customer's risk.

For a copy of our **Standard Terms and Conditions of Sale, Disclaimers of Warranty, Limitation of Liability and Remedy**, please contact McGill customer service, 1-219-465-2200. These terms and conditions of sale, disclaimers and limitations of liability apply to any person who may buy, acquire or use an Emerson Power Transmission Corporation product referred to herein, including any person who buys from a licensed distributor of these branded products.

All sales are made on our STANDARD TERMS AND CONDITIONS OF SALE in effect at the time a customer's order is accepted. The current Terms and Conditions are set forth below:

STANDARD TERMS AND CONDITIONS OF SALE (March 19, 1999)

These Terms and Conditions, the attendant quotation or acknowledgment and all documents incorporated by specific reference therein, will be the complete and exclusive statement of the terms of the agreement governing the sale of goods ("Goods") by **Emerson Power Transmission Corporation** and its divisions and subsidiaries ("Seller") to Customer ("Buyer"). Buyer's acceptance of the Goods will manifest Buyer's assent to these Terms and Conditions. If these Terms and Conditions differ in any way from the terms and conditions of Buyer's order, or other documentation, this document will be construed as a counteroffer and will not be deemed an acceptance of Buyer's terms and conditions which conflict herewith.

1. **PRICES:** Unless otherwise specified in writing by Seller, Seller's price for the goods shall remain in effect for thirty (30) days after the date of Seller's quotation or acknowledgment of Buyer's order for the Goods, whichever occurs first, provided an unconditional, complete authorization for the immediate shipment of the Goods is received and accepted by Seller within such time period. If such authorization is not received by Seller within such thirty (30) day period, Seller shall have the right to change the price for the Good to Seller's price for the Goods at the time of shipment.

2. **TAXES:** Any tax or governmental charge or increase in same hereafter becoming effective increasing the cost to Seller of producing, selling or delivering the Goods or of procuring material used therein, and any tax now in effect or increase in same payable by the Seller because of the manufacture, sale or delivery of the Goods, may at Seller's option, be added to the price.

3. **TERMS OF PAYMENT:** Subject to the approval of Seller's Credit Department, terms are net thirty (30) days from date of Seller's invoice in U.S. currency. If any payment owed to Seller is not paid when due, it shall bear interest, at a rate to be determined by Seller, which shall not exceed the maximum rate permitted by law, from the date on which it is due until it is paid. Seller shall have the right, among other remedies, either to terminate the Agreement or to suspend further performance under this and/or other agreements with Buyer in the event Buyer fails to make any payment when due. Buyer shall be liable for all expenses, including attorneys' fees, relating to the collection of past due amounts.

4. **SHIPMENT AND DELIVERY:** Shipments are made F.O.B. Seller's shipping point. Any claims for shortages or damages suffered in transit shall be submitted by the Buyer directly to the carrier. While Seller will use all reasonable commercial efforts to maintain the delivery date acknowledged or quoted by Seller, all shipping dates are approximate. Seller reserves the right to make partial shipments and to segregate "specials" and made-to-order Goods from normal stock Goods. Seller shall not be bound to tender delivery of any Goods for which Buyer has not provided shipping instructions.

5. **QUANTITY:** Buyer agrees to accept overruns of up to ten percent (10%) of the order on "made-to-order" Goods, including parts. Any such additional items shall be priced at the price per item charged for the specific quantity ordered.

6. **LIMITED WARRANTY:** Subject to the limitations of Section 7, Seller warrants that the Goods will be free from defects in material and workmanship under normal use, service and maintenance for a period of one year (unless otherwise specified by Seller in writing) from the date of shipment of the Goods by Seller. **THIS IS THE SOLE AND EXCLUSIVE WARRANTY GIVEN BY SELLER WITH RESPECT TO THE GOODS AND IS IN LIEU OF AND EXCLUDES ALL OTHER WARRANTIES, EXPRESS OR IMPLIED, ARISING BY OPERATION OF LAW OR OTHERWISE, INCLUDING WITHOUT LIMITATION, MERCHANTABILITY OR FITNESS FOR A PARTICULAR PURPOSE WHETHER OR NOT THE PURPOSE OR USE HAS BEEN DISCLOSED TO SELLER IN SPECIFICATIONS, DRAWINGS OR OTHERWISE, AND WHETHER OR NOT SELLER'S PRODUCTS ARE SPECIFICALLY DESIGNED AND/OR MANUFACTURED BY SELLER FOR BUYER'S USE OR PURPOSE.**

This warranty does not extend to any losses or damages due to misuse, accident, abuse, neglect, normal wear and tear, unauthorized modification or alteration, use beyond rated capacity, or improper installation, maintenance or application. To the extent that Buyer or its agents has supplied specifications, information, representation of operating conditions or other data to Seller in the selection or design of the Goods and the preparation of Seller's quotation, and in the event that actual operating conditions or other conditions differ from those represented by Buyer, any warranties or other provisions contained herein which are affected by such conditions shall be null and void. If within thirty (30) days after Buyer's discovery of any warranty defects within the warranty period, Buyer notifies Seller thereof in writing, Seller shall, at its option, repair or replace F.O.B. point of manufacture, or refund the purchase price for, that portion of the goods found by Seller to be defective. Failure by Buyer to give such written notice within the applicable time period shall be deemed an absolute and unconditional waiver of Buyer's claim for such defects. Goods repaired or replaced during the warranty period shall be covered by the foregoing warranty for the remainder of the original warranty period or ninety (90) days, whichever is longer. Buyer assumes all other responsibility for any loss, damage, or injury to persons or property arising out of, connected with, or resulting from the use of Goods, either alone or in combination with other products/components.

SECTIONS 6 AND 7 APPLY TO ANY ENTITY OR PERSON WHO MAY BUY, ACQUIRE OR USE SELLER'S GOODS, INCLUDING ANY ENTITY OR PERSON WHO BUYS THE GOODS FROM SELLER'S DISTRIBUTOR AND SUCH ENTITY OR PERSON SHALL BE BOUND BY THE LIMITATIONS THEREIN.

7. **LIMITATION OF REMEDY AND LIABILITY: THE SOLE AND EXCLUSIVE REMEDY FOR BREACH OF ANY WARRANTY HEREUNDER (OTHER THAN THE WARRANTY PROVIDED UNDER SECTION 13) SHALL BE LIMITED TO REPAIR, REPLACEMENT OR REFUND OF THE PURCHASE PRICE UNDER SECTION 6. SELLER SHALL NOT BE LIABLE FOR DAMAGES CAUSED BY DELAY IN PERFORMANCE AND IN NO EVENT, REGARDLESS OF THE FORM OF THE CLAIM OR CAUSE OF ACTION (WHETHER BASED IN CONTRACT, INFRINGEMENT, NEGLIGENCE, STRICT LIABILITY, OTHER TORT OR OTHERWISE), SHALL SELLER'S LIABILITY TO BUYER AND/OR ITS CUSTOMERS EXCEED THE PRICE TO BUYER OF THE SPECIFIC GOODS PROVIDED BY SELLER GIVING RISE TO THE CLAIM OR CAUSE OF ACTION. BUYER AGREES THAT IN NO EVENT SHALL SELLER'S LIABILITY TO BUYER AND/OR ITS CUSTOMERS EXTEND TO INCLUDE INCIDENTAL, CONSEQUENTIAL OR PUNITIVE DAMAGES. THE TERM "CONSEQUENTIAL DAMAGES" SHALL INCLUDE, BUT NOT BE LIMITED TO, LOSS OF ANTICIPATED PROFITS,**

LOSS OF USE, LOSS OF REVENUE, COST OF CAPITAL AND DAMAGE OR LOSS OF OTHER PROPERTY OR EQUIPMENT.

It is expressly understood that any technical advice furnished by Seller with respect to the use of the Goods is given without charge, and Seller assumes no obligation or liability for the advice given, or results obtained, all such advice being given and accepted at Buyer's risk.

GOODS AND/OR SERVICES SOLD HEREUNDER ARE NOT FOR USE IN ANY NUCLEAR AND RELATED APPLICATIONS. Buyer accepts goods and/or services with the foregoing understanding, agrees to communicate the same in writing to any subsequent purchaser or users and to defend, indemnify and hold harmless Seller from any claims, losses, suits, judgments and damages, including incidental and consequential damages, arising from such use, whether the cause of action be based in tort, contract or otherwise, including allegations that the Seller's liability is based on negligence or strict liability.

8. **EXCUSE OF PERFORMANCE:** Seller shall not be liable for delays in performance or for non-performance due to acts of God, acts of Buyer, war, riot, fire, flood, other severe weather, sabotage, or epidemics; strikes or labor disturbances; governmental requests, restrictions, laws, regulations, orders or actions; unavailability of or delays in transportation; default of suppliers; or unforeseen circumstances or any events or causes beyond Seller's reasonable control. Deliveries may be suspended for an appropriate period of time as a result of the foregoing. If Seller determines that its ability to supply the total demand for the Goods, or to obtain material used directly or indirectly in the manufacture of the Goods, is hindered, limited or made impracticable due to causes addressed in this Section 8, Seller may allocate its available supply of the Goods or such material (without obligation to acquire other supplies of any such Goods or material) among itself and its purchasers on such basis as Seller determines to be equitable without liability for any failure of performance which may result therefrom. Deliveries suspended or not made by reason of this section may be canceled by Seller upon notice to Buyer without liability, but the balance of the agreement shall otherwise remain unaffected.

9. **CANCELLATION:** The Buyer may cancel orders only upon written notice and upon payment to Seller of cancellation charges which include, among other things, all costs and expenses incurred and commitments made by the Seller and a reasonable profit thereon.

10. **CHANGES:** Buyer may request changes or additions to the Goods consistent with Seller's specifications and criteria. In the event such changes or additions are accepted by Seller, Seller may revise the price and delivery schedule. Seller reserves the right to change designs and specifications for the Goods without prior notice to Buyer, except with respect to Goods being made-to-order for Buyer.

11. **TOOLING:** Tool, die, and pattern charges, if any, are in addition to the price of the Goods and are due and payable upon completion of the tooling. All such tools, dies and patterns shall be and remain the property of Seller. Charges for tools, dies, and patterns do not convey to Buyer, title, ownership interests in, or rights to possession or removal, nor prevent their use by Seller for other purchasers, except as otherwise expressly provided by Seller and Buyer in writing with reference to this provision.

12. **ASSIGNMENT:** Buyer shall not assign its rights or delegate its duties hereunder or any interest therein or any rights hereunder without the prior written consent of the Seller, and any such assignment, without such consent, shall be void.

13. **PATENTS AND COPYRIGHTS:** Subject to Section 7, Seller warrants that the Goods sold, except as are made specifically for Buyer according to Buyer's specifications, do not infringe any valid U.S. patent or copyright in existence as of the date of delivery. This warranty is given upon the condition that Buyer promptly notify Seller of any claim or suit involving Buyer in which such infringement is alleged, and that Buyer cooperate fully with Seller and permit Seller to control completely the defense or compromise of any such allegation of infringement. Seller's warranty as to use only applies to infringements arising solely out of the inherent operation (i) of such Goods, or (ii) of any combination of Goods in a system designed by Seller. In the event such Goods, singularly or in combination, are held to infringe a U.S. patent or copyright in such suit, and the use of such Goods is enjoined, or in the case of a compromise by Seller, Seller shall have the right, at its option and expense, to procure for Buyer the right to continue using such Goods, or replace them with non-infringing Goods; or modify same to become non-infringing; or grant Buyer a credit for the depreciated value of such Goods and accept return of them.

14. **MISCELLANEOUS:** These terms and conditions set forth the entire understanding and agreement between Seller and Buyer, and supersede all other communications, negotiations and prior oral or written statements regarding the subject matter of these terms and conditions. No change, modification, rescission, discharge, abandonment, or waiver of these terms and conditions of Sale shall be binding upon the Seller unless made in writing and signed on its behalf by an officer of the Seller. No conditions, usage or trade, course of dealing or performance, understanding or agreement purporting to modify, vary, explain, or supplement these Terms and Conditions shall be binding unless hereafter made in writing and signed by the party to be bound, and no modification shall be affected by the acceptance of purchase orders or shipping instruction forms containing terms at variance with or in addition to those set forth herein. No waiver by Seller with respect to any breach or default or any right or remedy and no course of dealing, shall be deemed to constitute a continuing waiver of any other breach or default or of any other right or remedy, unless such waiver be expressed in writing and signed by the party to be bound. Seller is not responsible for typographical or clerical errors made in any quotation, orders or publications. All such errors are subject to correction. The validity, performance, and all other matters relating to the interpretation and effect of this contract shall be governed by the law of the state of New York.

CAM FOLLOWER AND SPECIALTY BEARINGS

McGill precision bearings, including the original CAMROL® cam follower bearings, are available in a wide variety of standard and special “MTO” designs to suit the application.

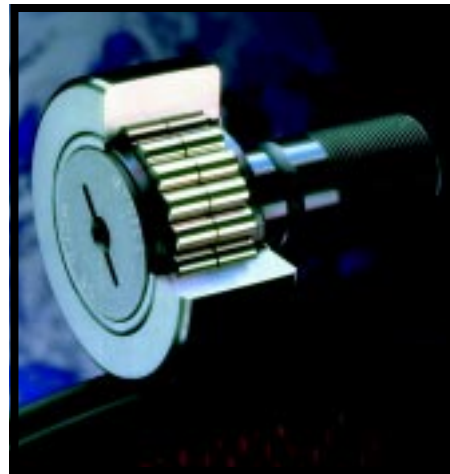
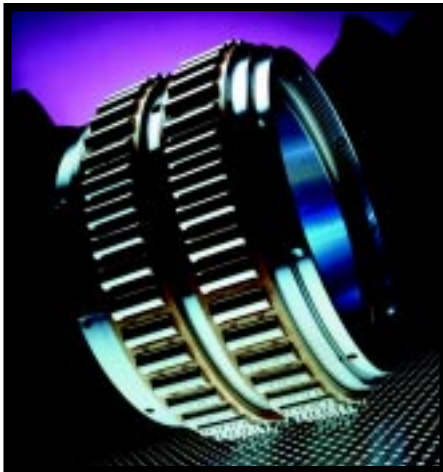

For ordering information, contact your authorized McGill Distributor or contact McGill Customer Service:
Telephone 1-219-465-2200 • Fax 1-219-465-2290



EMERSON POWER TRANSMISSION

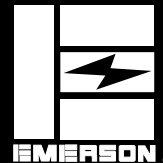

Browning
Helical Speed
Reducers & Gearmotors



SEALMASTER
Mounted Ball Bearings



MORSE
Clutches



Browning
Shaft Mount Reducers



SEALMASTER
Mounted Roller Bearings



ROLLWAY
Roller Bearings



Browning
V-Belt Drives



MORSE
Chain



KOP-FLEX
Couplings



Van Gorp
Conveyor Pulleys



MORSE
Worm Gearing



McGILL
Precision Bearings

FOR ORDERING INFORMATION,
CONTACT YOUR AUTHORIZED
MCGILL DISTRIBUTOR OR
CONTACT MCGILL CUSTOMER SERVICE

McGILL MANUFACTURING CO., INC.
909 North Lafayette St.
Valparaiso, IN 46383
Telephone 219-465-2200
Fax 219-465-2290

OTHER EPT CUSTOMER SERVICE CENTERS

BROWNING, KOP-FLEX & VAN GORP
Maysville, KY 41056
Telephone 606-564-2011
1-800-626-2120
Fax 606-564-2052
1-800-262-3292

MORSE & SEALMASTER
7120 Buffington Rd.
P.O. Box 728
Florence, KY 41022
Telephone 606-342-7900
1-800-354-9825
Fax 606-342-5652
606-342-5654

EMERSON POWER TRANSMISSION – WEST
3553 Placentia Ct.
Chino, CA 91710
Telephone 909-591-9561
1-800-468-3751
Other 1-800-421-6047
Fax 909-465-1955
1-800-261-6516

KOP-FLEX, INC.
P.O. Box 1696
Baltimore, MD 21203
Telephone 410-768-2000
Fax 410-787-8433

LIPE-ROLLWAY CORPORATION
P.O. Box 4827
Syracuse, NY 13221
Telephone 315-457-6211
Fax 315-451-8596
1-800-448-2260

EMERSON POWER TRANSMISSION – CANADA
9999 Highway 48
Markham, ONT L3P 3J3
Telephone 905-294-9330
1-800-268-4149
Fax 1-800-668-9005

EMERSON POWER TRANSMISSION – EXPORT
7120 Buffington Rd.
Florence, KY 41042
Telephone 606-727-5273
606-727-0721

Form #8656 4/99 25M
Printed in U.S.A.

www.emerson-ept.com



ویرا پرداز آروین پاسارگاد

با مدیریت خانم مهندس احمدی



جهت مشاوره

با کارشناسان فنی

با ما در ارتباط باشید



021 - 91001377



0935 125 90 98